

# Operator's Manual

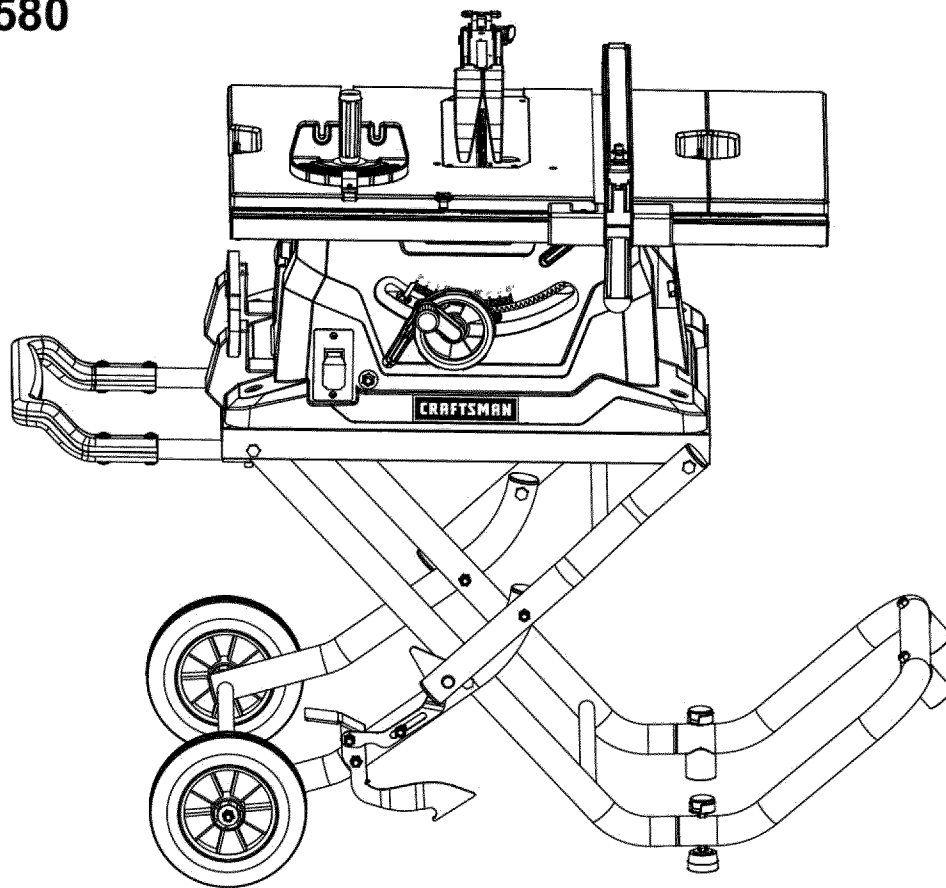

## 10" TABLE SAW WITH FOLDABLE STAND

Model No.  
141.142580



### CAUTION:

Read and follow all Safety Rules and Operating Instructions before First Use of this Product. Keep this Manual with Tool.

- Safety
- Unpacking
- Assembly
- Operation
- Maintenance
- Parts List
- Español

Sears Brands Management Corp., Hoffman Estates, IL 60179 U.S.A.  
[www.craftsman.com](http://www.craftsman.com)

## TABLE OF CONTENTS

Warranty	2
Safety Rules	2-4
Unpacking	4-6
Assembly	7-16
Installation	18-19
Operation	19-27
Maintenance	27-29
Troubleshooting	31
Repair Protection Agreement	32
Parts Illustration and List	33-44
Español	45-78

## WARRANTY

### CRAFTSMAN ONE YEAR LIMITED WARRANTY

FOR ONE YEAR from the date of purchase, this product is warranted against defects in material or workmanship. With proof of purchase, a defective product will receive free repair or replacement at option of seller.

For warranty coverage details to obtain free replacement, visit the web page: [www.craftsman.com/warranty](http://www.craftsman.com/warranty)

This warranty does not cover the blade or belt, which are expendable parts that can wear out from normal use within the warranty period. This ONE YEAR warranty is void if this product is ever used while providing commercial services or if rented to another person. For 90 DAY commercial and rental use terms, see the Craftsman warranty web page.

This warranty gives you specific legal rights, and you may also have other rights which vary from state to state.

Sears Brands Management Corporation, Hoffman Estates, IL 60179

## SAFETY RULES

### WARNING: Read and understand all instructions.

Failure to follow all instructions listed below, may result in electric shock, fire and/or serious personal injury.

### GENERAL SAFETY RULES

**PROPOSITION 65 WARNING:** Some dust created by using power tools contain chemicals known to the state of California to cause cancer, birth defects or other reproductive harm.

Some examples of these chemicals are:

- Lead from lead-based paints.
- Crystalline silica from bricks and cement and other masonry products.
- Arsenic and chromium from chemically-treated lumber.

Your risk from these exposures vary, depending on how often you do this type of work. To reduce your exposure to these chemicals: work in a well ventilated area and work with approved safety equipment. Always wear OSHA/NIOSH approved, properly fitting face mask or respirator when using such tools.

**CAUTION:** Always follow proper operating procedures as defined in this manual — even if you are familiar with use of this or similar tools. Remember that being careless for even a fraction of a second can result in severe personal injury.

Sears Brands Management Corporation

**WARNING:** THIS PRODUCT CONTAINS LEAD. A CHEMICAL KNOWN TO THE STATE OF CALIFORNIA TO CAUSE CANCER AND BIRTH DEFECTS OR OTHER REPRODUCTIVE HARM. **WASH HANDS AFTER HANDLING.**

- **KNOW YOUR POWER TOOL.** Read the operator's manual carefully. Learn the saw's applications and limitations as well as the specific potential hazards related to this tool.
- **GUARD AGAINST ELECTRICAL SHOCK BY PREVENTING BODY CONTACT WITH GROUNDED SURFACES.** For example, pipes, radiators, ranges, refrigerator enclosures.
- **KEEP GUARDS IN PLACE** and in good working order.
- **REMOVE ADJUSTING KEYS AND WRENCHES.** Form habit of checking to see that keys and adjusting wrenches are removed from tool before turning it on.
- **KEEP WORK AREA CLEAN.** Cluttered areas and benches invite accidents. **DO NOT** leave tools or pieces of wood on the saw while it is in operation.
- **DO NOT USE IN DANGEROUS ENVIRONMENTS.** Do not use power tools in damp or wet locations or expose to rain. Keep the work area well lit.
- **KEEP CHILDREN AND VISITORS AWAY.** All visitors should wear safety glasses and be kept a safe distance from work area. Do not let visitors contact tool or extension cord while operating.
- **MAKE WORKSHOP CHILDPROOF** with padlocks and master switches, or by removing starter keys.
- **DON'T FORCE TOOL.** It will do the job better and safer at the feed rate for which it was designed.
- **USE RIGHT TOOL.** Don't force the tool or attachment to do a job it was not designed for. Don't use it for a purpose not intended.
- **USE THE PROPER EXTENSION CORD.** Make sure your extension cord is in good condition. Use only a cord heavy enough to carry the current your product will draw. An undersized cord will cause a drop in line voltage resulting in loss of power and overheating. A wire gauge size (A.W.G.) of at least 14 is recommended for an extension cord 25 feet or less in length. If in doubt, use the next heavier gauge. The smaller the gauge number, the heavier the cord.
- **DRESS PROPERLY.** Do not wear loose clothing, gloves, neckties, or jewelry. They can get caught and draw you into moving parts. Rubber gloves and nonskid footwear are recommended when working outdoors. Also wear protective hair covering to contain long hair.
- **ALWAYS** wear safety goggles that comply with United States ANSI Z87.1 and a face shield or dust mask if operation is dusty. Everyday eyeglasses have only impact-resistant lenses, they are **NOT** safety glasses.
- **SECURE WORK.** Use a featherboard to hold work when practical. It's safer than using your hand and frees both hands to operate tool.
- **DON'T OVERREACH.** Keep proper footing and balance at all times.
- **MAINTAIN TOOLS WITH CARE.** Keep tools sharp and clean for better and safer performance. Follow instructions for lubricating and changing accessories.
- **DISCONNECT TOOLS.** When not in use, before servicing, or when changing attachments, blades, bits, cutters, etc., all tools should be disconnected.
- **AVOID ACCIDENTAL STARTING.** Be sure switch is off when plugging in any tool.

- **USE RECOMMENDED ACCESSORIES.** Consult the operator's manual for recommended accessories. The use of improper accessories may risk injury.
  - **NEVER STAND ON TOOL.** Serious injury could occur if the tool is tipped or if the cutting tool is unintentionally contacted.
  - **CHECK DAMAGED PARTS.** Before further use of the tool, a guard or other part that is damaged should be carefully checked to determine that it will operate properly and perform its intended function. Check for alignment of moving parts, binding of moving parts, breakage of parts, mounting and any other conditions that may affect its operation. A guard or other part that is damaged must be properly repaired or replaced by an authorized service center to avoid risk of personal injury.
  - **USE THE RIGHT DIRECTION OF FEED.** Feed work into a blade or cutter against the direction of rotation of blade or cutter only.
  - **NEVER LEAVE TOOL RUNNING UNATTENDED. TURN THE POWER OFF.** Don't leave tool until it comes to a complete stop.
  - **PROTECT YOUR LUNGS.** Wear a face or dust mask if the cutting operation is dusty.
  - **PROTECT YOUR HEARING.** Wear ear plugs or muffs during extended periods of operation.
  - **DO NOT ABUSE CORD.** Never yank cord to disconnect from receptacle. Keep cord away from heat, oil, and sharp edges.
  - **WHEN OPERATING A POWER TOOL OUTSIDE, USE AN OUTDOOR EXTENSION CORD MARKED "W-A" OR "W".** These cords are rated for outdoor use and reduce the risk of electric shock.
  - **ALWAYS KEEP THE BLADE GUARD AND SPREADER (RIVING KNIFE) IN PLACE** and in working order.
  - **KEEP BLADES CLEAN, SHARP, AND WITH SUFFICIENT SET.** Sharp blades minimize stalling and kickback.
  - **KEEP HANDS AWAY FROM CUTTING AREA.** Keep hands away from blades. Do not reach underneath work or around or over the blade while blade is rotating. Do not attempt to remove cut material when blade is moving.
  - **BLADE COASTS AFTER BEING TURNED OFF.**
  - **NEVER USE IN AN EXPLOSIVE ATMOSPHERE.** Normal sparking of the motor could ignite fumes.
  - **ISPECT TOOL CORDS PERIODICALLY.** If damaged, have repaired by a qualified service technician at an authorized service facility. The conductor with insulation having an outer surface that is green with or without yellow stripes is the equipment-grounding conductor. If repair or replacement of the electric cord or plug is necessary, do not connect the equipment-grounding conductor to a live terminal. Repair or replace a damaged or worn cord immediately. Stay constantly aware of cord location and keep it well away from the rotating blade.
  - **INSPECT EXTENSION CORDS PERIODICALLY** and replace if damaged.
  - **GROUND ALL TOOLS.** If tool is equipped with three-prong plug, it should be plugged into a three-hole electrical receptacle.
  - **CHECK WITH A QUALIFIED ELECTRICIAN** or service personnel if the grounding instructions are not completely understood or if in doubt as to whether the tool is properly grounded.
  - **USE ONLY CORRECT ELECTRICAL DEVICES:** 3-wire extension cords that have 3-prong grounding plugs and 3-pole receptacles that accept the tool's plug.
  - **DO NOT MODIFY** the plug provided. If it will not fit the outlet, have the proper outlet installed by a qualified electrician.
  - **KEEP TOOL DRY, CLEAN, AND FREE FROM OIL AND GREASE.** Always use a clean cloth when cleaning. Never use brake fluids, gasoline, petroleum-based products, or any solvents to clean tool.
  - **STAY ALERT AND EXERCISE CONTROL.** Watch what you are doing and use common sense. Do not operate tool when you are tired. Do not rush.
  - **DO NOT USE TOOL IF SWITCH DOES NOT TURN IT ON AND OFF.** Have defective switches replaced by an authorized service center.
  - **USE ONLY CORRECT BLADES.** Do not use blades with incorrect size holes. Never use blade washers or blade bolts that are defective or incorrect. The maximum blade capacity of your saw is 10 in.
  - **BEFORE MAKING A CUT, BE SURE ALL ADJUSTMENTS ARE SECURE.**
  - **BE SURE BLADE PATH IS FREE OF NAILS.** Inspect for and remove all nails from lumber before cutting.
  - **NEVER TOUCH BLADE** or other moving parts during use.
  - **NEVER START A TOOL WHEN ANY ROTATING COMPONENT IS IN CONTACT WITH THE WORKPIECE.**
  - **DO NOT OPERATE A TOOL WHILE UNDER THE INFLUENCE OF DRUGS, ALCOHOL, OR ANY MEDICATION.**
  - **WHEN SERVICING** use only identical replacement parts. Use of any other parts may create a hazard or cause product damage.
  - **USE ONLY RECOMMENDED ACCESSORIES** listed in this manual or addendums. Use of accessories that are not listed may cause the risk of personal injury. Instructions for safe use of accessories are included with the accessory.
  - **DOUBLE CHECK ALL SETUPS.** Make sure blade is tight and not making contact with saw or workpiece before connecting to power supply.
- ### SPECIFIC SAFETY RULES
- **FIRMLY BOLT THE SAW TO A WORK BENCH OR LEG STAND** at approximately hip height.
  - **NEVER OPERATE THE SAW ON THE FLOOR.**
  - **KEEP GUARDS IN PLACE** and in good working order.
  - **GUARD AGAINST KICKBACK.** Kickback occurs when the blade stalls rapidly and workpiece is driven back towards the operator. It can pull your hand into the blade resulting in serious personal injury. Stay out of blade path and turn switch off immediately if blade binds or stalls.
  - **USE RIP FENCE.** Always use a fence or straight edge guide when ripping.
  - **SUPPORT LARGE PANELS.** To minimize risk of blade pinching and kickback, always support large panels.
  - **REMOVE ALL FENCES AND AUXILIARY TABLES** before transporting saw. Failure to do so can result in an accident causing possible serious personal injury.
  - **DON'T OVERREACH.** Keep proper footing and balance at all times.
  - **NEVER place arms or hands in line with the path of the cutting blade.**
  - **ALWAYS USE BLADE GUARD, RIVING KNIFE, AND**

**ANTI-KICKBACK PAWLS** on all “through-sawing” operations. Through-sawing operations are those in which the blade cuts completely through the workpiece as in ripping or cross cutting. Keep the blade guard down, the anti-kickback pawls down, and the spreader in place over the blade.

- **ALWAYS SECURE WORK** firmly against the rip fence or miter gauge. NEVER use the rip fence during the same operation as the miter gauge.
- **ALWAYS USE A PUSH STICK FOR RIPPING NARROW STOCK.** A push stick is a device used to push a workpiece through the blade instead of using your hands. Size and shape can vary but the push stick must always be narrower than the workpiece to prevent the push stick from contacting the saw blade. When ripping narrow stock, always use a push stick, so your hand does not come close to the saw blade. Use a featherboard and push blocks for non-through cuts.
- **NEVER** perform any operation “freehand” which means using only your hands to support or guide the workpiece. Always use either the rip fence or miter fence to position and guide the work.
- **NEVER** stand or have any part of your body in line with the path of the saw blade.
- **NEVER** reach behind, over, or within three inches of the blade or cutter with either hand for any reason.
- **MOVE THE RIP FENCE** out of the way when cross cutting.
- **DO NOT USE THE MITER GAUGE AND RIP FENCE** during the same operation.
- **NEVER** attempt to free a stalled saw blade without first turning the saw **OFF** and disconnecting the saw from the power source.
- **PROVIDE ADEQUATE SUPPORT** to the rear and sides of the saw table for wide or long work pieces.
- **AVOID KICKBACKS** (work thrown back toward you) by:
  - a) Keeping blade sharp.
  - b) Keeping rip fence parallel to the saw blade.
  - c) Keeping spreader, anti-kickback pawls, and blade guard in place and operating.
  - d) Not releasing the work before it is pushed all the way past the saw blade using a push stick.
  - e) Not ripping work that is twisted or warped or does not have a straight edge to guide along the fence.
- **IF THE POWER SUPPLY CORD IS DAMAGED**, it must be replaced only by the manufacturer or by an authorized service center to avoid risk.
- **AVOID AWKWARD OPERATIONS AND HAND POSITIONS** where a sudden slip could cause your hand to move into the cutting tool.
- **USE ONLY RECOMMENDED ACCESSORIES** listed in this manual or addendums. Use of accessories that are not listed may cause the risk of personal injury. Instructions for safe use of accessories are included with the accessory.
- **MAKE SURE THE WORK AREA HAS AMPLE LIGHTING** to see the work and that no obstructions will interfere with safe operation **BEFORE** performing any work using the table saw.
- **ALWAYS TURN OFF SAW** before disconnecting it, to avoid accidental starting when reconnecting to power supply.
- **SAVE THESE INSTRUCTIONS.** Refer to them frequently and use to instruct other users. If you loan someone this tool, loan them these instructions also.

## THINK SAFETY

Safety is a combination of operator common sense and alertness at all times when the saw is being used.

**CAUTION:** Follow safety instructions that appear on the front of your saw.

## UNPACKING

Refer to Figures 1-2.

This product requires assembly.

- Open shipping box. Remove all parts and saw body with leg stand assembly B from the box and separate the parts.

**NOTE:** This tool is heavy. To avoid back injury, keep your knees bent and lift with your legs, not your back, and get help when needed.

- Place the saw body with leg stand assembly B on the cardboard or an old blanket on floor in order to protect the leg stand.
- Lay out the parts and check them against the parts as shown illustrations Fig. 1a-1b.

**CAUTION:** Do not attempt assembly if parts are missing. Use this manual to order replacement parts.

Check for shipping damage or missing parts. If any parts are damaged or missing, call 1-888-980-5058 for replacement.

The saw is factory set for accurate cutting. After assembling it, check for accuracy. If shipping has influenced the settings, refer to specific procedures explained in this manual.

The table saw body with leg stand assembly B comes assembled as one unit. Additional parts which need to be fastened to the saw should be located and accounted for before assembling:

- A Blade Guard Assembly
- B Anti-kickback Pawl Assembly
- C Miter Gauge Assembly
- D Rip Fence Assembly
- E Dust Extraction Port
- F Table Insert for Dado Cutting
- G Push Stick
- H Blade Wrench (2)
- I Stand support
- J Handle Assembly
- K Wheel (2)
- L Locking Knob (2)
- M Shock Absorption Pad
- N Leveling Foot Assembly
- O Roller Sleeve (2)

### Parts bag includes:

- M6 x 35 Socket Head Bolt (2)
- M8 x 65 Socket Head Bolt
- M8 Flat Washer
- M8 Big Flat Washer (2)
- M10 Big Flat Washer (2)
- M6 Hex Nut (2)
- M8 Hex Nut (2)
- 6mm Hex Wrench

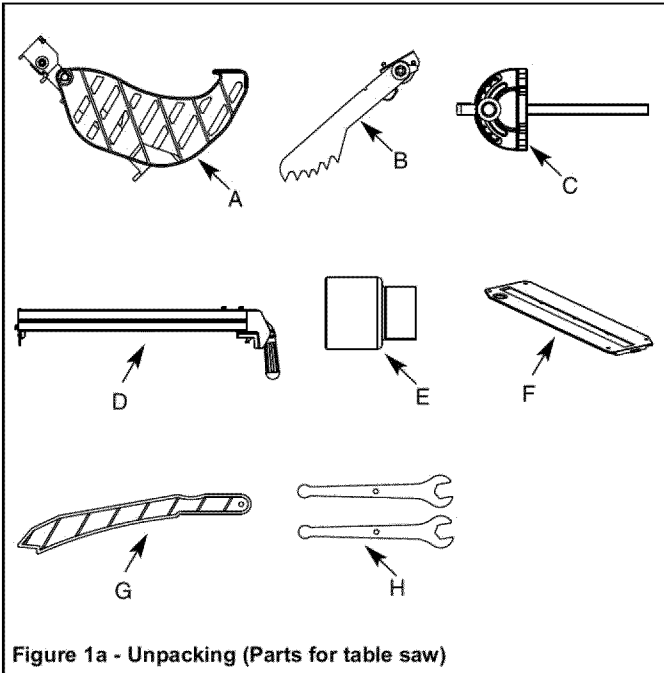

Figure 1a - Unpacking (Parts for table saw)

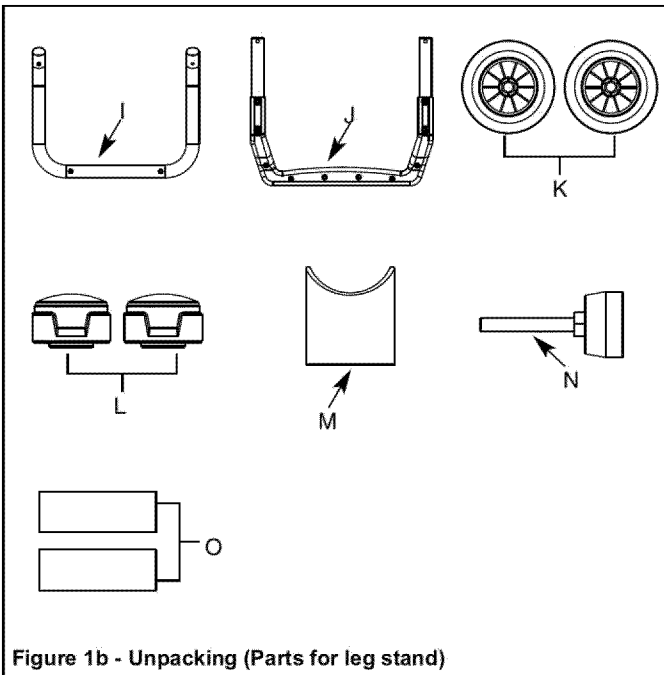

Figure 1b - Unpacking (Parts for leg stand)

## KNOW YOUR TABLE SAW

Refer to Figure 2.

The safe use of this product requires an understanding of the information on the tool and in this operator's manual as well as a knowledge of the project you are attempting. Before use of this product, familiarize yourself with all operating features and safety rules.

**ANTI-KICKBACK PAWLS:** Kickback is a hazard in which the workpiece is thrown back toward the operator. The teeth on the anti-kickback pawls point away from the workpiece. If the workpiece should be pulled back toward the operator, the teeth dig into the wood to help prevent or reduce the possibility of kickback.

**BEVEL SCALE:** The easy-to-read scale on the front of the workstand shows the exact blade angle.

**BLADE:** For maximum performance, it is recommended that you use the 40-tooth, 10 in. carbide tipped combination blade provided with your saw. The blade is raised and lowered with the height/bevel adjusting handwheel. Bevel angles are locked with the bevel locking lever.

**WARNING:** Do not use blades rated less than the speed of this tool. Failure to heed this warning could result in personal injury.

**BLADE GUARD:** Always keep the guard down over the blade for through-sawing cuts.

**BEVEL LOCKING LEVER:** This lever under the worktable surface on the front of the cabinet, locks the angle setting of the blade.

**HEIGHT/BEVEL ADJUSTING HANDWHEEL:** Located on the front of the cabinet, this handwheel is used to lower and raise the blade for adjustments or blade replacement. The handwheel also makes the adjustment for bevel angles easy.

**RIP FENCE LOCKING LEVER:** The lever on the front of the rip fence releases the rip fence or locks it in place.

**EXTENSION TABLE LOCKING LEVER:** The lever under worktable surface releases the extension table or locks it in place.

**MITER GAUGE:** This miter gauge aligns the wood for a cross cut. The easy-to-read indicator shows the exact angle for a miter cut, with positive stops at 0°, 22.5° and 45°.

**MITER GAUGE GROOVES:** The miter gauge rides in these grooves on either side of the blade.

**RAIL:** Front rail provide support for the rip fence.

**RIP FENCE:** A sturdy metal fence guides the workpiece and is secured with the locking lever. Grooves run along the top and sides of the rip fence for use with optional clamps and accessories.

**SCALE:** Located on the front rail, the easy-to-read scale provides precise measurements for rip cuts.

**RIVING KNIFE:** A metal piece of the blade guard assembly, slightly thinner than the saw blade, which helps keep the kerf open and prevent kickback.

**SWITCH ASSEMBLY:** This saw has an easy access power switch. To lock the switch in the **OFF** position, remove the yellow switch key from the switch. Place the key in a location that is inaccessible to children and others not qualified to use the tool.

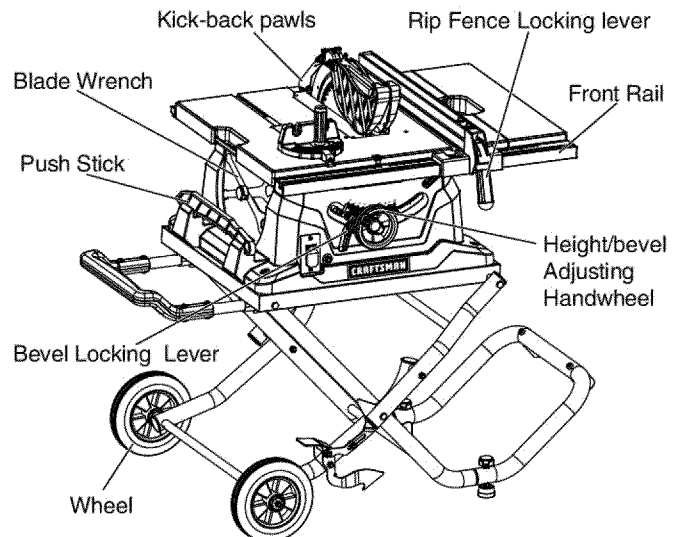

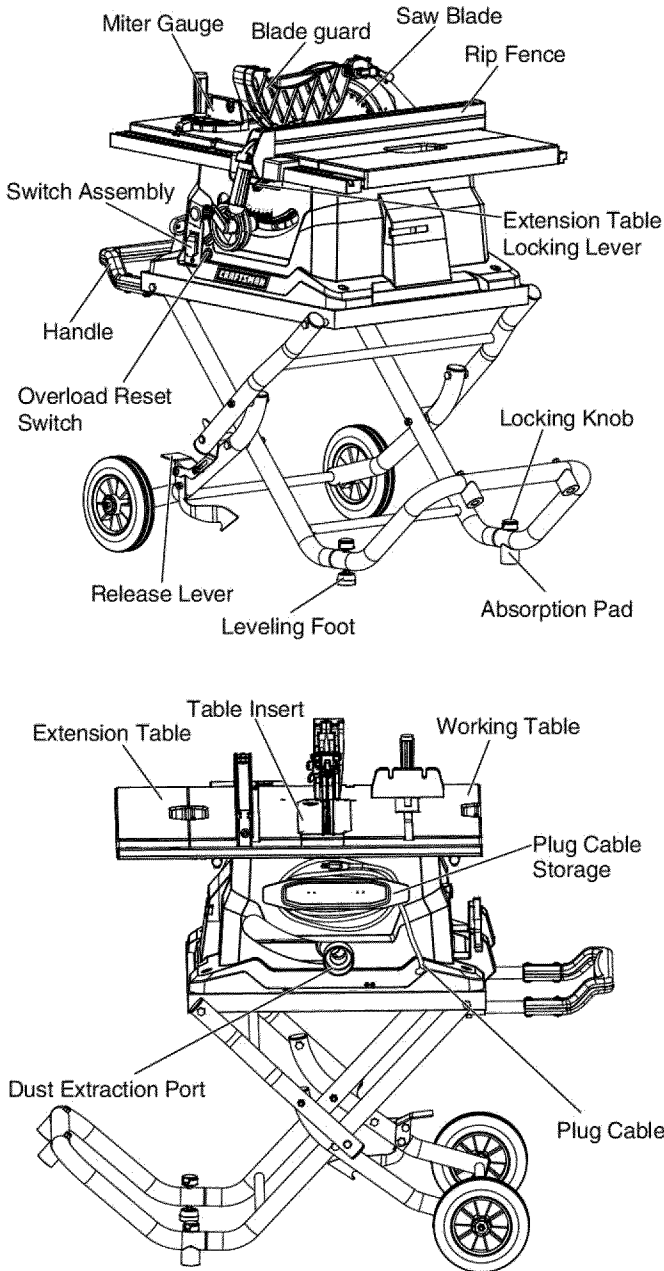

Figure 2

## OPERATING COMPONENTS

The upper portion of the blade projects up through the table and is surrounded by an insert called the throat plate. The height of the blade is set with a handwheel on the front of the cabinet. To accommodate wide panels, the saw table has rails on right side. Detailed instructions are provided in the Operation section of this manual for the basic cuts: cross cuts, miter cuts, bevel cuts, and compound cuts.

The rip fence is used to position work for lengthwise cuts. A scale on the front rail shows the distance between the rip fence and the blade.

It is very important to use the blade guard assembly for all through-sawing operations. The blade guard assembly includes: riving knife, anti-kickback pawls, and plastic blade guard.

## SWITCH ASSEMBLY

Refer to Figure 3.

This saw is equipped with a switch assembly that has a built-in locking feature. This feature is intended to prevent unauthorized and possible hazardous use by children and others.

### TO TURN YOUR SAW ON:

- With the switch key inserted into the switch, lift the switch to turn **ON ( I )**.

### TO TURN YOUR SAW OFF:

- Press the switch down to turn **OFF ( O )**.

### TO LOCK YOUR SAW:

- Press the switch down.
- Remove the switch key from the switch and store in a safe, secure location.

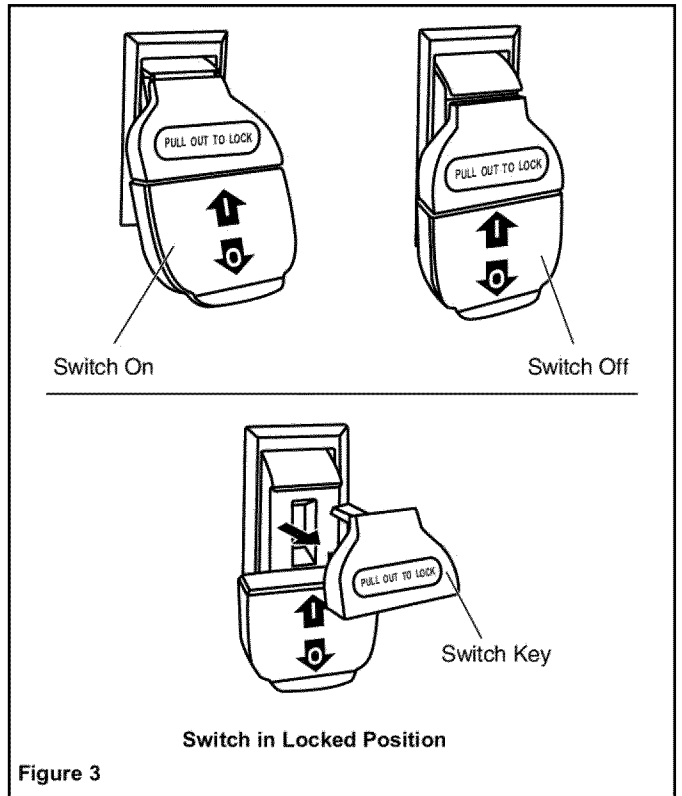

Figure 3

**WARNING:** Always remove the switch key when the tool is not in use and keep it in a safe place. In the event of a power failure, turn the switch **OFF ( O )** and remove the key. This action will prevent the tool from accidentally starting when power returns.

**WARNING: ALWAYS** make sure your workpiece is not in contact with the blade before operating the switch to start the tool. Failure to heed this warning may cause the workpiece to be kicked back toward the operator and result in serious personal injury

**WARNING:** To reduce the risk of accidental starting, always make sure the switch is in the **OFF ( O )** position before plugging tool into the power source.

Double-insulated construction.

**DANGER, KEEP HANDS AWAY FROM BLADE.**

## ASSEMBLY

Refer to Figures 4-42.

**CAUTION:** Do not attempt assembly if parts are missing. Use this manual to order replacement parts.

Be certain all parts are clean and free of shipping preservative. Also, completely remove all parts of packing.

**WARNING:** Do not connect the plug to the outlet until all installations and adjustments have been completed and you have read and understood the safety and operational instructions.

### ASSEMBLE THE LEG STAND

Refer to Figures 4-5.

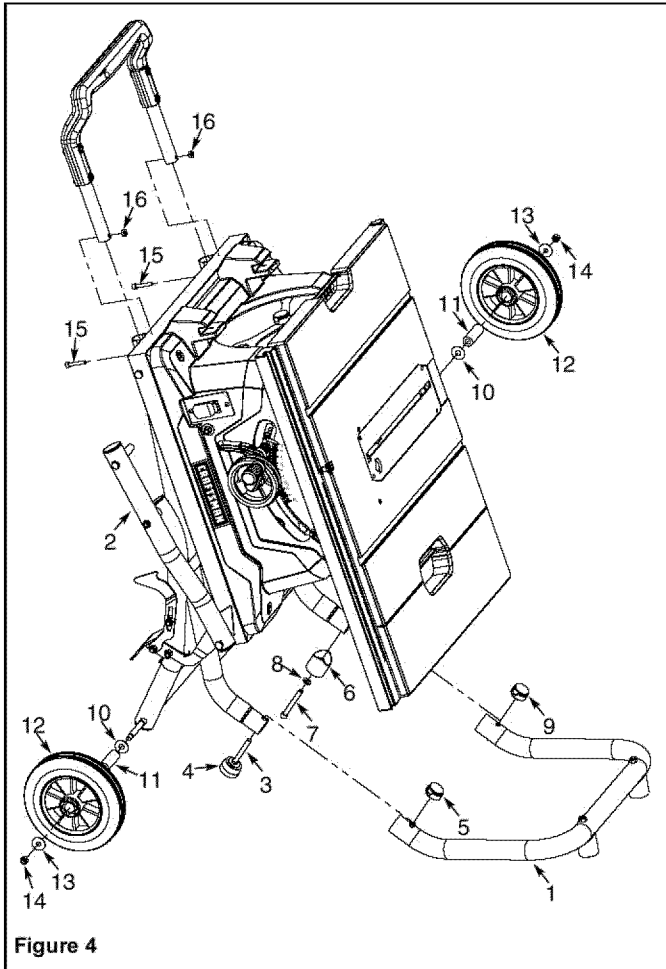

Figure 4

- Group the leg stand parts by type and size. Refer to figure 1b for correct quantities.
- Attach the tubes of the stand support (1) with the corresponding tubes of the stand assembly (2) and align the holes.
- Insert the M8 x 75 socket head bolt (3) on the leveling foot (4) assembly into the hole (with a M8 hex nut welded on it) and tighten the bolt (3) with 6mm hex wrench (supplied). Secure the locking knob (5) by turning it clockwise.
- Secure the shock absorption pad (6) with a M8 x 65 socket head bolt (7) and a M8 flat washer (8) on the other hole with 6mm hex wrench (supplied). Tighten the locking knob (9) clockwise.
- Slide one M10 big flat washer (10), roller sleeve (11), wheel (12) and M8 big flat washer (13) and M8 hex nut (14) on the axle

through the hole in the center of the wheel (12).

Secure in place using the adjustable wrench or 13mm wrench (not supplied).

Repeat with the second wheel (12).

- Attach the handle assembly to leg stand assembly (2) with two M6 x 35 socket head bolts (15) and M6 hex nuts (16) as shown in Figure 4.
- Figure 5 is complete open leg stand assembly.

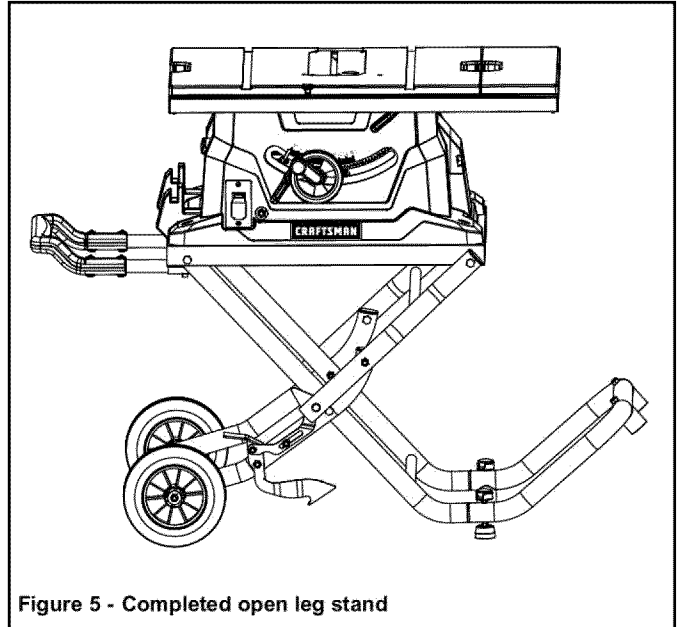

Figure 5 - Completed open leg stand

- Place the leg stand on a level surface and level the stand to the floor.

**NOTE:** Be sure that the leg stand is securely locked in an open position and that the shock absorption pad stabilized the table saw before operation.

**WARNING:** DO NOT OPERATE THIS MACHINE ON THE FLOOR. THIS IS A VERY DANGEROUS POSITION.

### TO SECURE/LEVEL THE TABLE SAW

Refer to Figure 6.

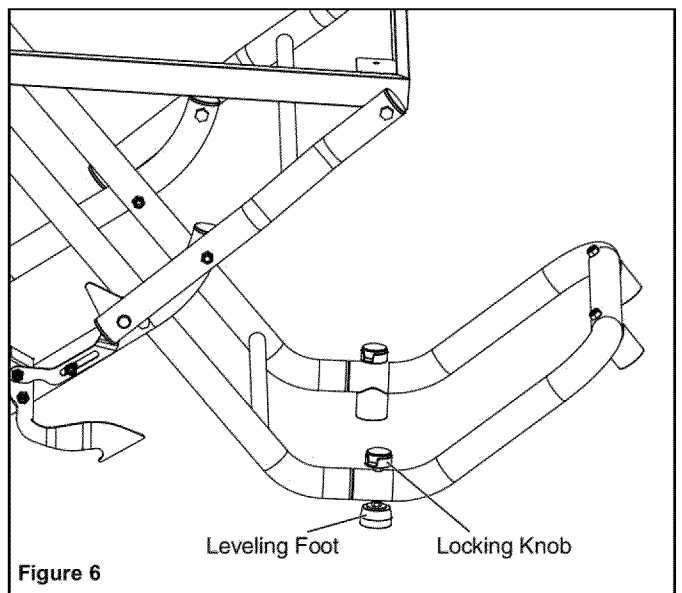

Figure 6

With the stand open and the table saw resting on a flat, level surface, the table saw should not move or rock from side to side.

If the table saw rocks from side to side, the leveling foot need adjusting until the stand is balanced.

- Loosen the locking knob counterclockwise.
- Lift the table saw slightly so that you may turn the leveling foot until the stand no longer rocks.
- Turning clockwise will lower the foot.
- Turning counterclockwise will raise the foot.

### TO OPEN THE LEG STAND

Refer to Figures 7-9.

- Grasp the handle on the stand and stand the table saw upright as shown Figure 7.

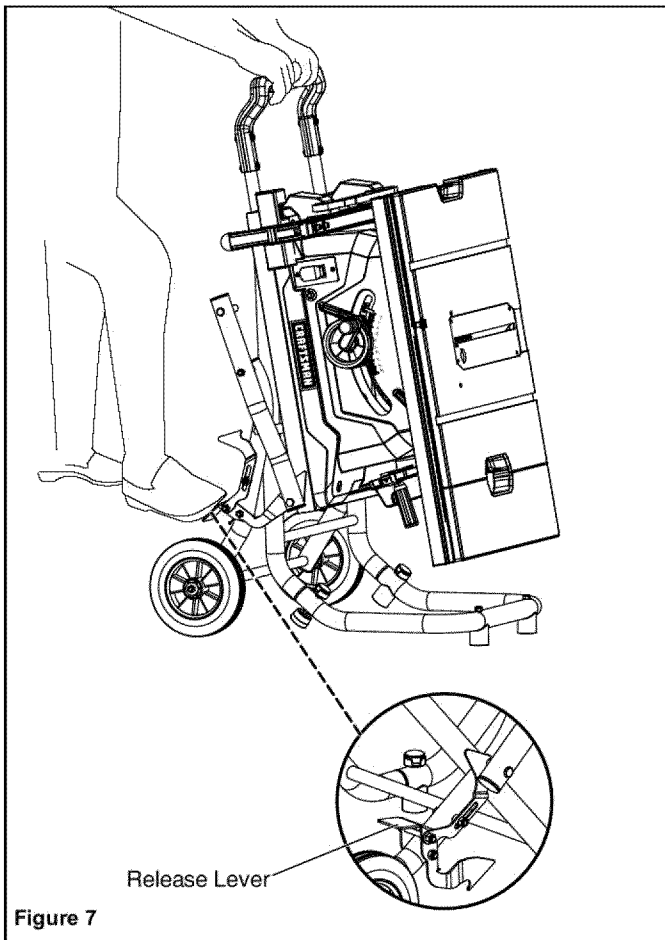

- Step on the release lever and pull the handle toward you at the same time.
- Once lever releases, continue to grasp handle and push stand down towards floor until saw is in horizontal position (Figure 9).
- With your hands on the handle, push the stand towards the ground until the table saw is in an open position. (Figure. 9)

**NOTE:** The release lever will close over the center brace, locking the stand in an open position. (Figure. 9)

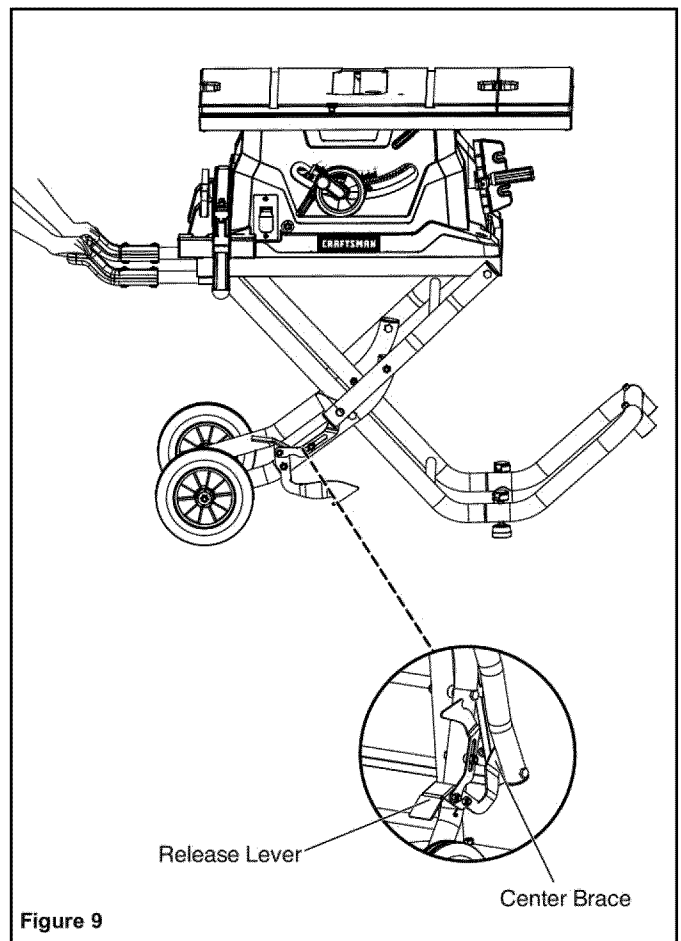
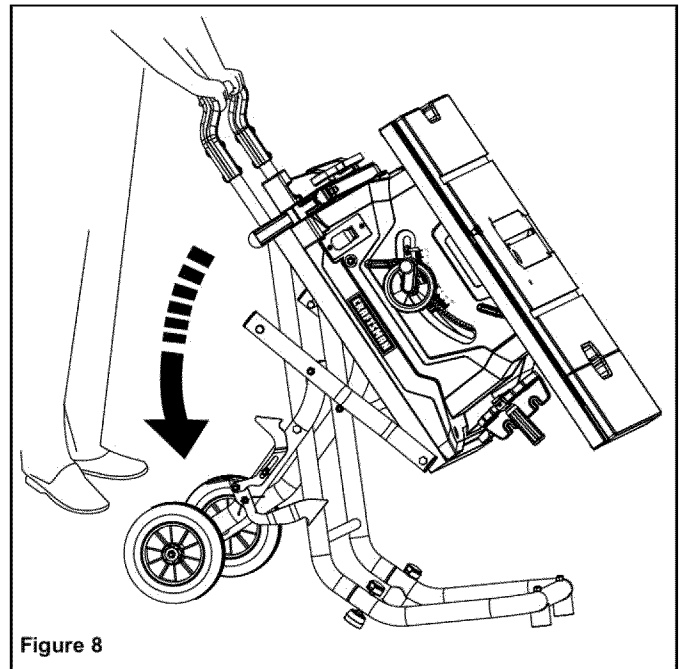



## TO STORE THE TABLE SAW ACCESSORIES

Refer to Figure 10.

The table saw has three convenient storage areas (one on either side and back of the saw cabinet) specifically designed for the saw's accessories. These accessories must be securely stored and remove the blade guard and anti-kickback pawls assembly prior to closing the stand and moving the saw.

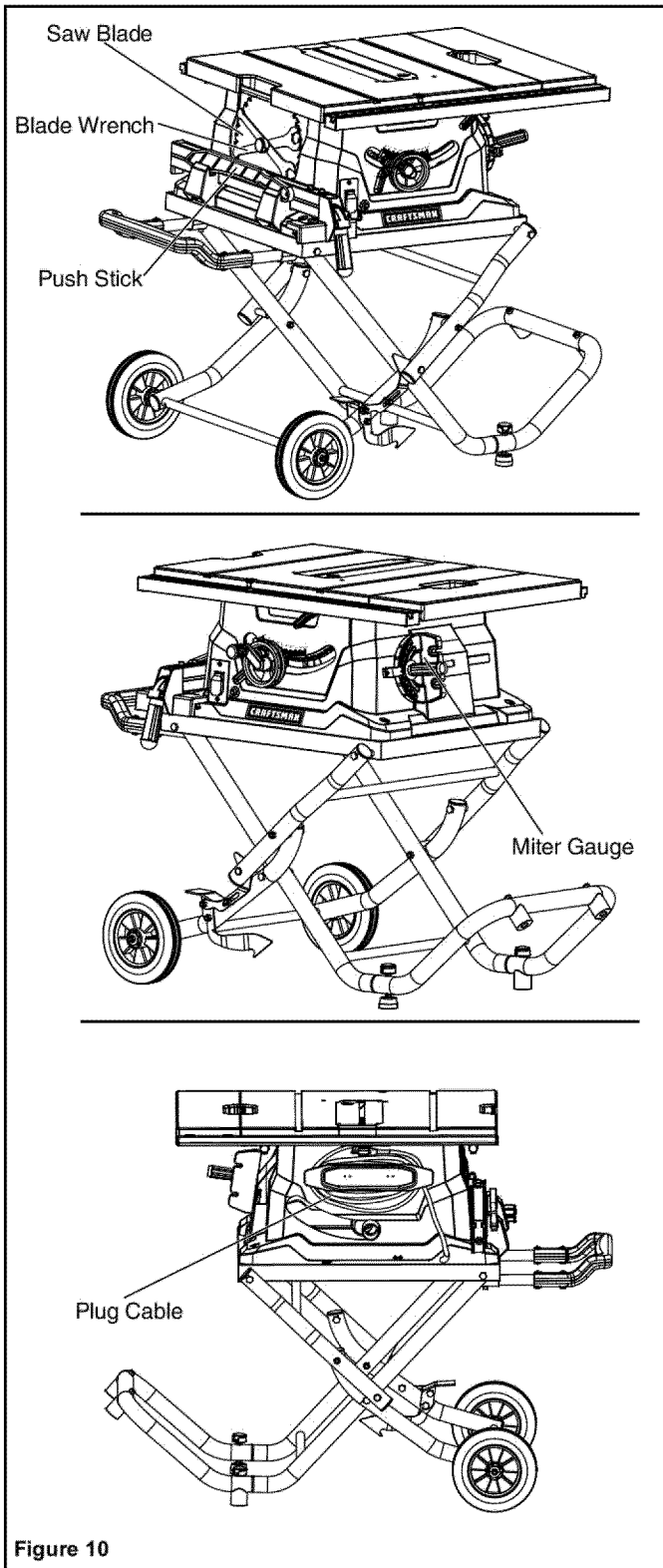

Figure 10

## TO CLOSE THE LEG STAND AND MOVE THE SAW

Refer to Figures 11-14.

- Remove any workpieces from the tool.
- Remove the blade guard and anti-kickback pawls assembly.
- Remove and securely store any tools or accessories such as rip fence, mitre gauge, push stick, etc.
- Push the extension table closed.
- Lower the saw blade.

### To close the leg stand:

Refer to Figures 11-12.

- At the same time, grasp the handle, step on the release lever, and lift up on the handle.

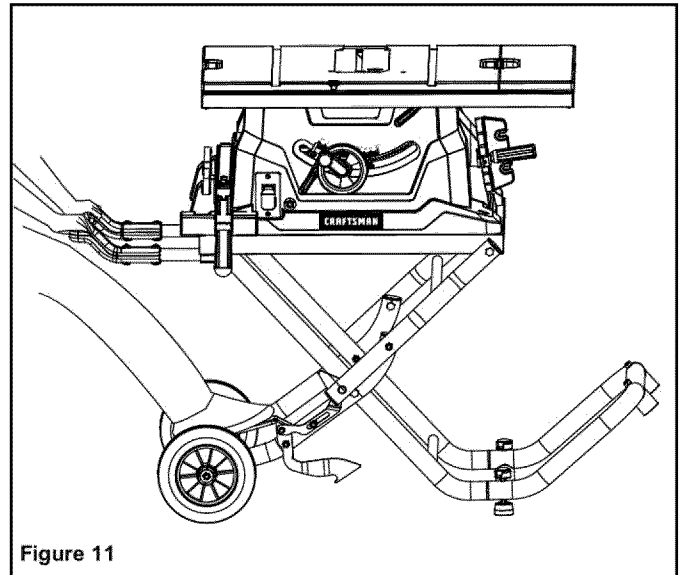

- Continue to grasp handle and allow weight of saw to rotate saw down until release lever clicks and locks into place.

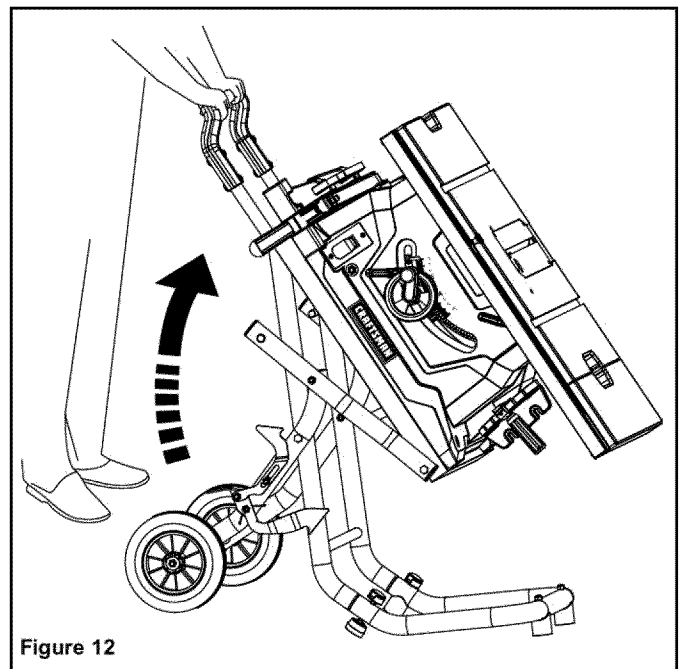

Figure 12

### To move the leg stand:

Refer to Figures 13-14.

- Grasping the handle firmly, place foot on axle bar for leverage, and pull handle back towards you until the stand is balanced on the wheels.

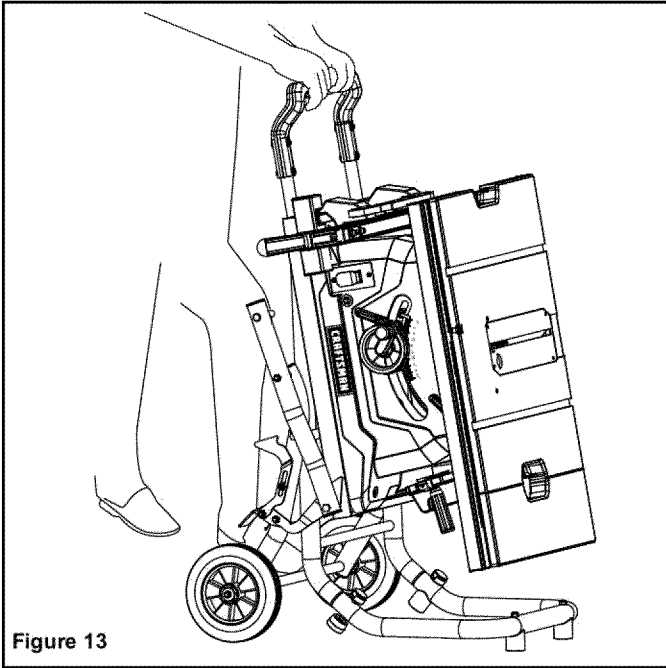

Figure 13

- Push the table saw to the desired location then either open the stand for saw operation or store the table saw in a dry environment.

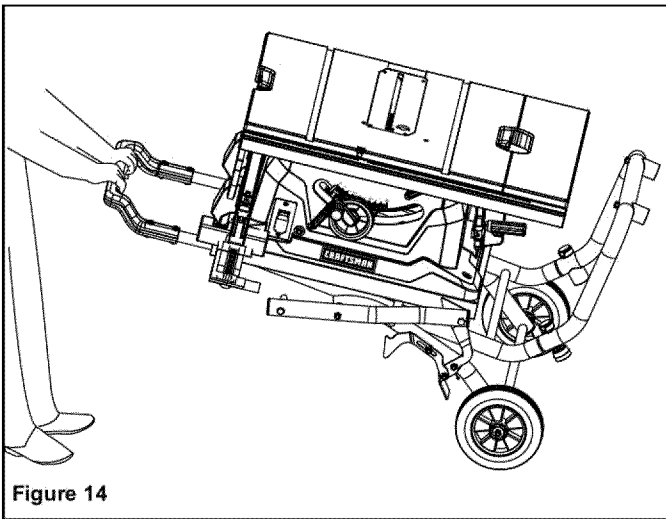

Figure 14

### HEIGHT/BEVEL ADJUSTING HANDWHEEL

Refer to Figure 15.

- Turn the height adjusting knob clockwise to raise the blade, and counterclockwise to lower the blade.
- Turn the handwheel clockwise, and move along the arc rail, then the blade will bevel from 0° to 45°, or turn counterclockwise.
- Secure the blade bevel lock lever when the bevel angle pointer points at desired angle on scale. To lock the blade when turn blade bevel lock lever clockwise. To unlock the blade turn it counterclockwise.

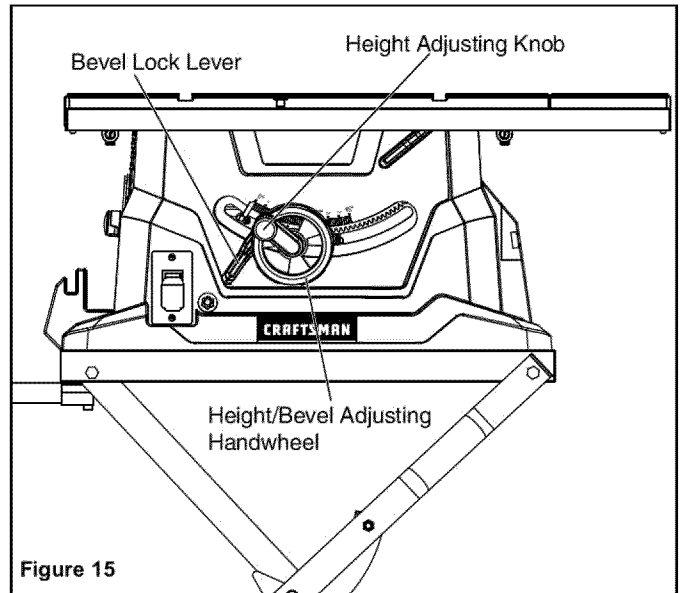

Figure 15

### TO REMOVE/REPLACE/ALIGN THE TABLE INSERT

Refer to Figures 16-17.

**WARNING:** The table insert must be level with the saw table. If the table insert is too high or too low, the workpiece can catch on the uneven edges resulting in binding or kickback which could result in serious personal injury.

Lower the blade by:

- Turn the height adjusting knob counterclockwise to lower the blade.
- Lock the blade by turning bevel lock lever clockwise.
- **To remove the table insert:** Place your index finger in the hole and lift the front end, pulling the throat plate out toward the front of the saw.
- **To reinstall the table insert:** Slip the tab into the slot at the back of the saw and push down to secure in place.

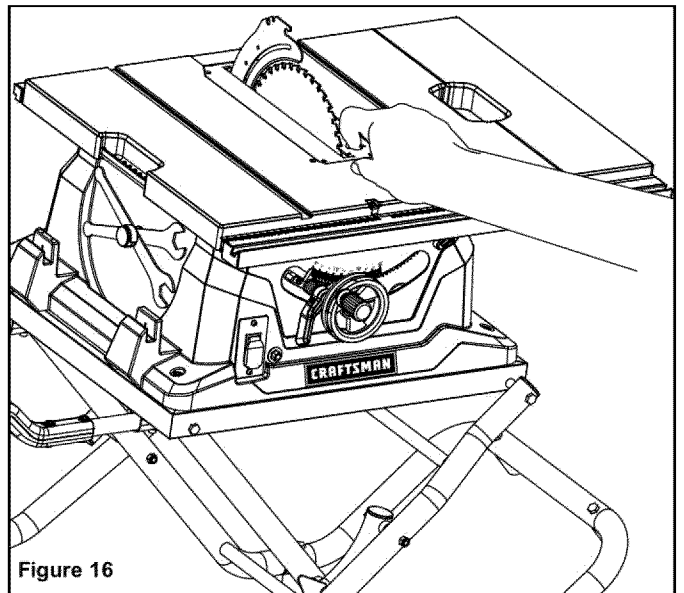

Figure 16

Using a screwdriver, adjust the four set screws until the table insert is level with the saw blade.

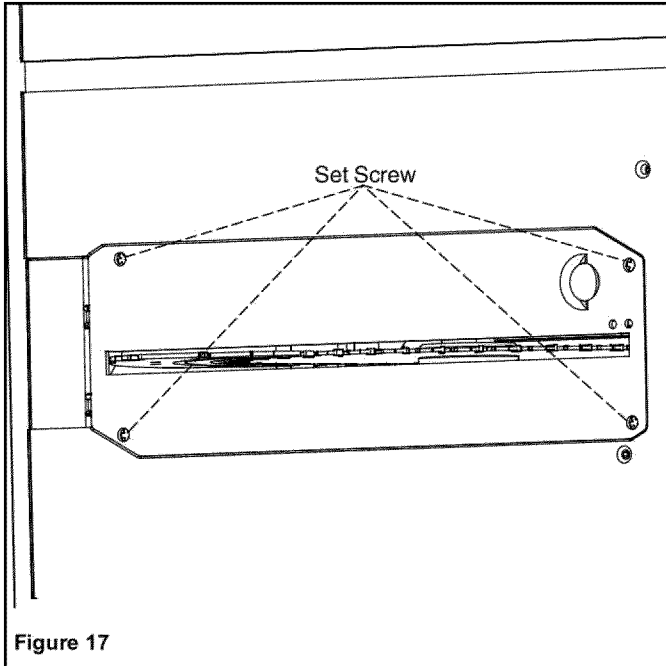

Figure 17

### TO CHECK SAW BLADE INSTALLATION

Refer to Figure 18.

The saw is shipped with the blade installed. Prior to initial use, it is recommended that you check the blade installation as instructed below.

**CAUTION:** To work properly, the saw blade teeth must point down toward the front of the saw. Failure to heed this instruction could cause damage to the saw blade, the saw, or the workpiece.

**NOTE:** Arbor shaft has left-hand threads.

- Unplug the saw.
- Remove blade wrenches from storage area by unscrewing the knob.
- Lower the saw blade and remove the table insert.
- Turn the bevel locking lever clockwise to tighten it securely. Raise the saw blade to its full height by turning the height adjusting knob clockwise.

#### To loosen the blade:

- Using one opened-ended blade wrench, place the flat open end on the flats on the inner blade flange.
- Using the other opened-ended blade wrench, place the flat open end on the flats on the arbor nut. Holding both wrenches firmly, pull the opened-ended blade wrench on the arbor nut forward to the front of the machine.

#### To tighten the blade:

- Using one opened-ended blade wrench, place the flat open end on the flats on the inner blade flange.
- Using the other opened-ended blade wrench, place the flat open end on the flats on the arbor nut. Holding both wrenches firmly, pull the opened-ended blade wrench on the arbor nut forward to the back of the machine. Make sure the arbor nut is securely tightened. Do not overtighten.
- Check all clearances for free blade rotation.

**NOTE:** For blade installation and removal instructions, see TO REPLACE THE BLADE in the Maintenance section of this manual.

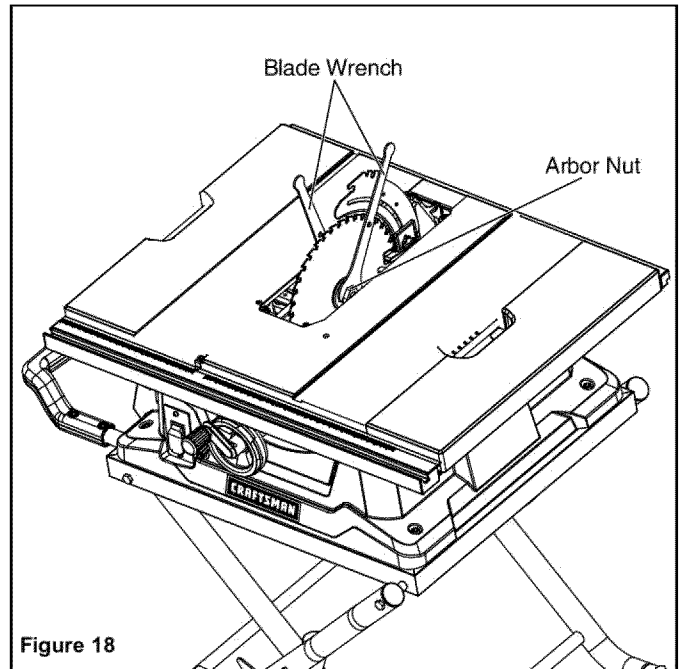

Figure 18

### ADJUSTING THE RIVING KNIFE

Refer to Figures 19-21.

This saw is shipped with the riving knife placed in “down” position.

**WARNING:** Riving knife has three holes for three positions. The highest position is for all through cuts. The middle position is for rabbets and other non-through cuts, (with blade guard and anti-kickback pawls removed). The lowest position is for dado cuts (with blade guard and anti-kickback pawls removed).

- Make sure locking pin is aligned with riving knife hole and secure in position by pushing the release lever up.
- Riving knife must be in line with blade. Make sure riving knife sits flat against mounting bracket and lock plate.

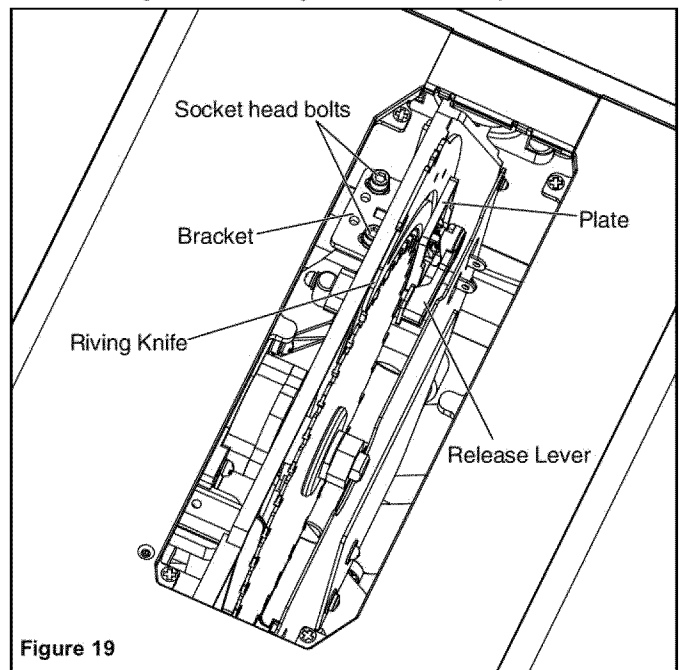

Figure 19

- Unplug the saw.

**To place in the highest position for all through cuts:**

- Remove the table insert.
- Raise the saw blade by turning the height adjusting knob clockwise.
- Unlock the release lever by pushing the lever up.
- Grasp the riving knife and push it towards the right to unlock it from the locking pin then pull it up or down until the pin is reengaged and the riving knife is in the highest position.
- Lock the release lever by pushing the lever down.
- Reinstall the table insert.

**To place in the middle position for non-through cuts e.g. rabbets**

- Remove the table insert.
- Raise the saw blade by turning the height adjusting knob clockwise.
- Unlock the release lever by pushing the lever up.
- Grasp the riving knife and push it towards the right to unlock it from the locking pin then pull it up or down until the pin is reengaged and the riving knife is in the middle position.
- Lock the release lever by pushing the lever down.
- Reinstall the table insert.

**To place in the lowest position for dado cuts:**

- Remove the table insert.
- Raise the saw blade by turning the height adjusting knob clockwise.
- Unlock the release lever by pushing the lever up.
- Grasp the riving knife and push it towards the right to unlock it from the locking pin then pull it up or down until the pin is reengaged and the riving knife is in the lowest position.
- Lock the release lever by pushing the lever down.
- Reinstall the table insert.

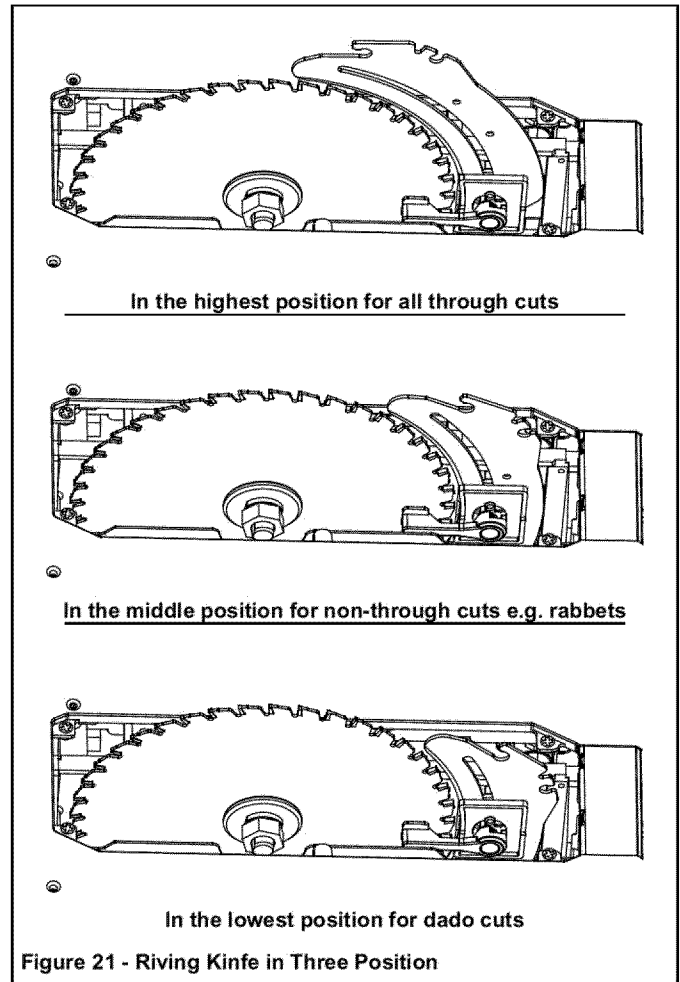

**TO INSTALL THE ANTI-KICKBACK PAWLS AND BLADE GUARD**

Refer to Figures 22-25.

**NOTE:** Anti-kickback pawls should only be installed for through cuts.

- Unplug the saw.
- Raise the saw blade to maximum height by turning height adjustment wheel clockwise.
- Place the riving knife in the highest position.

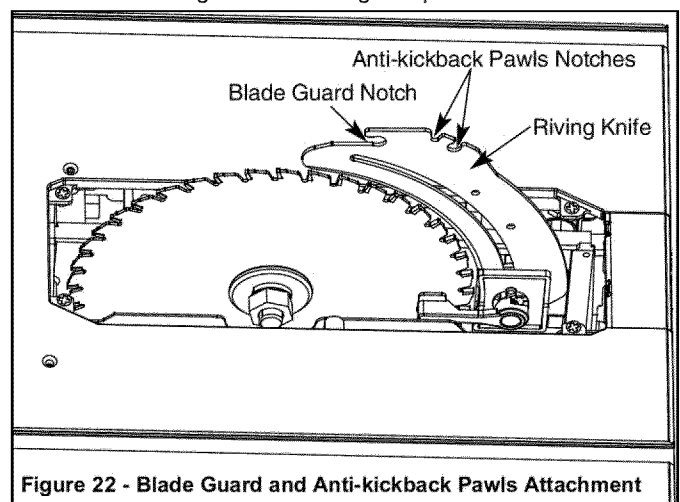
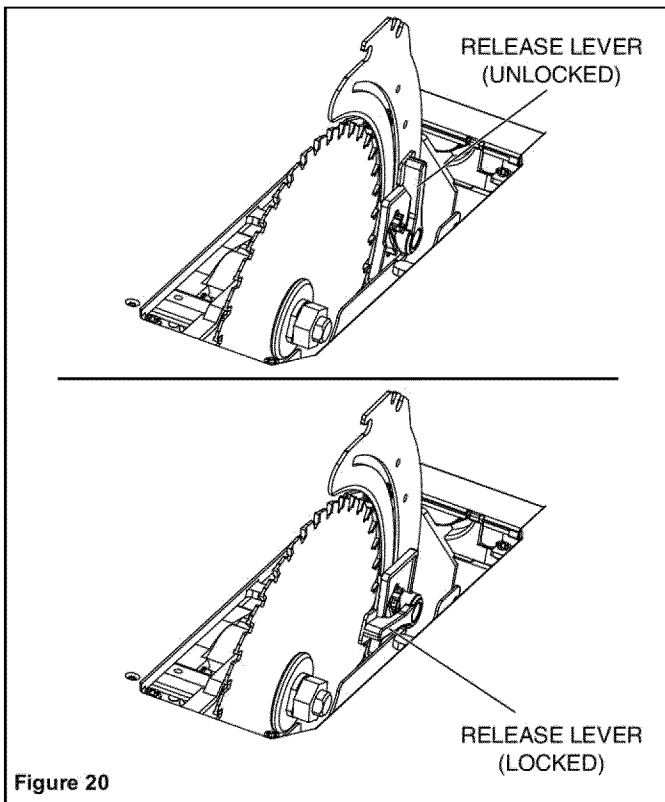

**To install anti-kickback pawls:**

- Unplug the saw.
- Place the anti-kickback pawls assembly onto riving knife at notches indicated. The spring pin is placed in the front notch and bolt is placed in the rear notch.
- Press anti-kickback pawls assembly completely down and push latch down to secure in position.

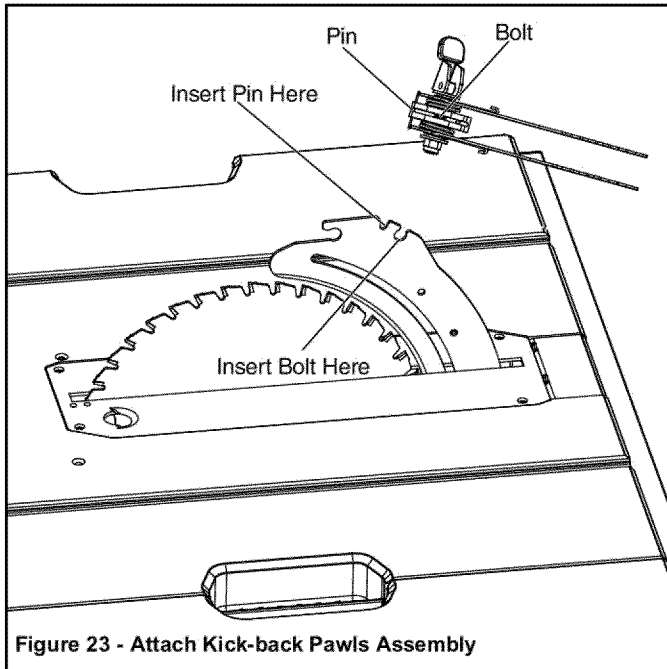

Figure 23 - Attach Kick-back Pawls Assembly

**To install the blade guard:**

- Unplug the saw.
- Place the slot of blade guard body over the riving knife. Slot of bushing is placed in the notch indicated in Figures 22 and 24.

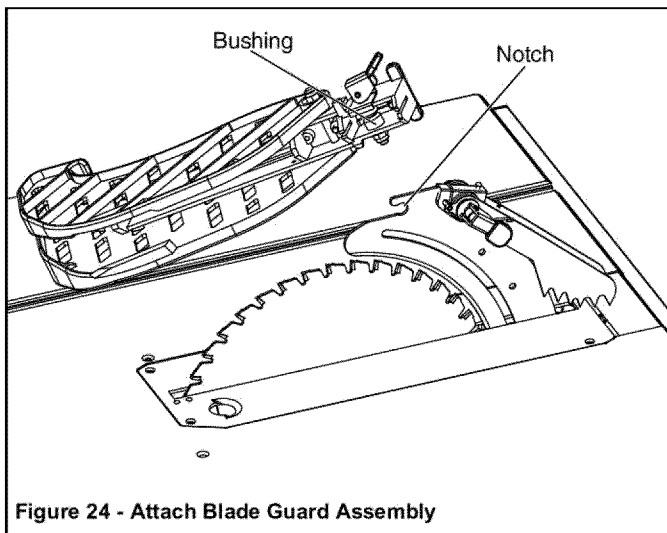

Figure 24 - Attach Blade Guard Assembly

- The bushings have a beveled edge and must be located in the center of the notch to lock properly.
- Pull guard fully back onto knife and push latch down to lock guard into position.

**NOTE:** Blade guard body should be parallel to the table. If not, adjust the set screws with 2 mm hex key (not supplied) as necessary. (Refer to figure 25)

**NOTE:** The teeth of anti-kickback pawls should touch table surface. Use set screw with 2 mm hex key (not supplied) to adjust if needed. (Refer to figure 25)

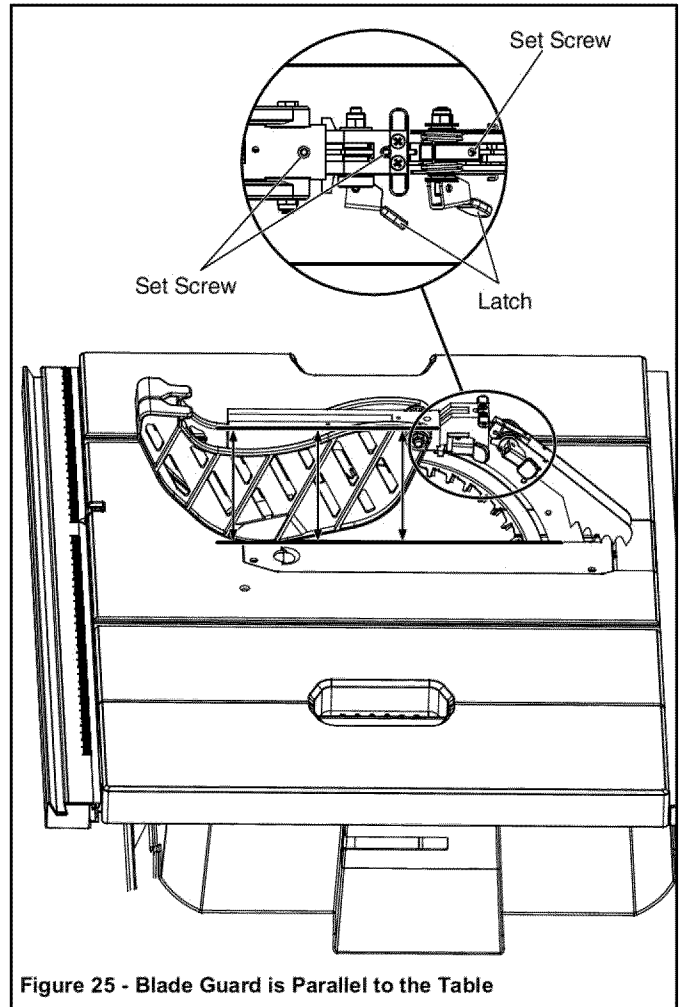

Figure 25 - Blade Guard is Parallel to the Table

**CHECK AND ALIGN THE RIVING KNIFE AND SAW BLADE**

Refer to Figures 26-27.

**NOTE:** If the riving knife is out of alignment with the saw blade, adjustment is needed.

**To check the alignment of the riving knife:**

- Unplug the saw.
- Raise the saw blade as high as it will go by turning the adjusting knob clockwise.
- Remove the anti-kickback pawls, and place a framing square or straight edge against both the saw blade and the riving knife.

**NOTE:** Place the framing square between the carbide teeth, and measure from the blade. This step will ensure that the framing square is square against the blade from the front to the back of the blade.

- The saw blade and riving knife are aligned when the framing square contacts the blade and the riving knife evenly, with no gaps.

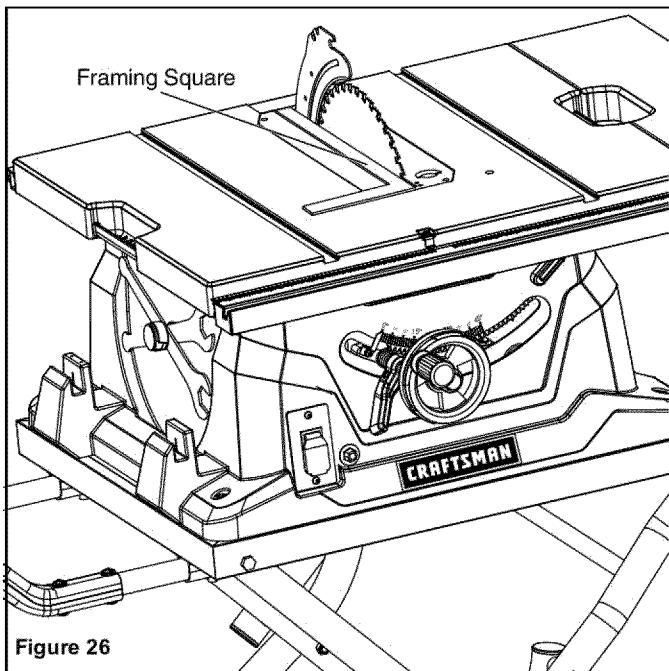

Figure 26

**To adjust:**

- Unplug the saw.
- Loosen the two M6 x 20 socket head bolts that hold the mounting bracket using the 5 mm hex wrench (not included).
- Reposition the blade guard assembly left or right, as required in order aligning the riving knife with the saw blade.
- Once properly aligned, securely retighten the socket head bolts.

**NOTE:** The blade guard and riving knife must always be correctly aligned so that the cut workpiece will pass on either side of the riving knife without binding or twisting to the side.

**WARNING:** Improper riving knife alignment can cause kickback and serious injury.

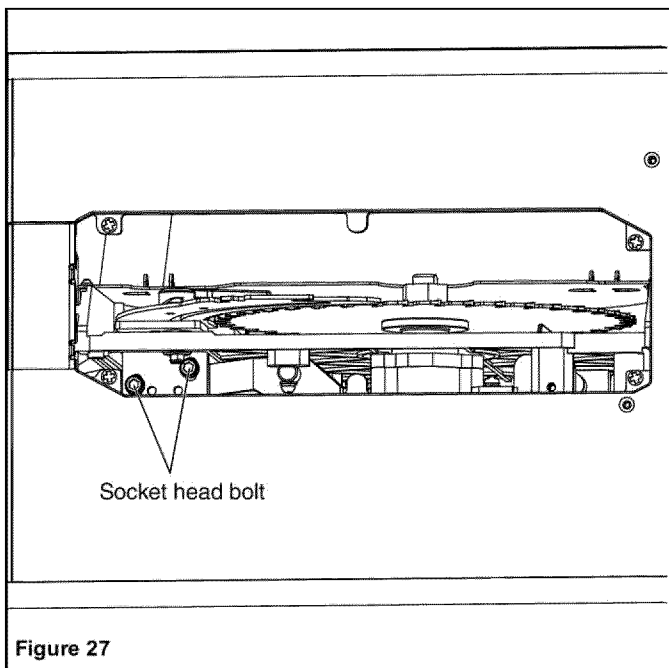

Figure 27

**CHANGING THE BLADE DEPTH**

Refer to Figure 28.

The saw blade depth should be set so that the outer points of the saw blade are higher than the workpiece by approximately 1/8" (3.2 mm) to 1/4" (6.4 mm), but the lowest points (gullets) are below the top surface.

- Unplug the saw.
- Turn the bevel locking lever clockwise to tighten it securely.
- Raise the blade by turning the height adjusting knob clockwise, or lower it by turning the handle counterclockwise.

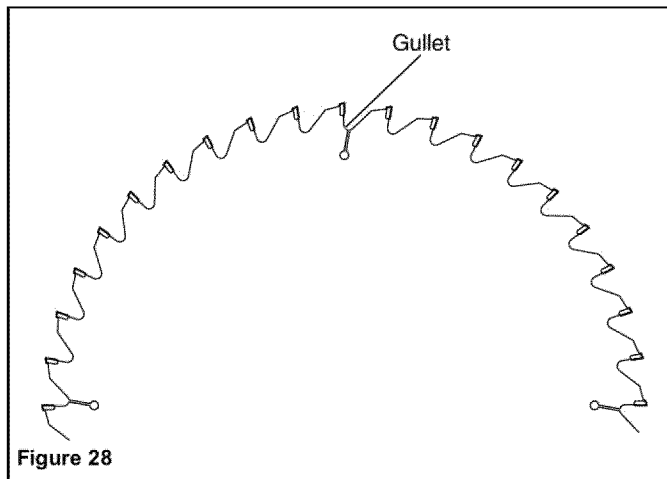

Figure 28

**CHANGING THE BLADE ANGLE**

Refer to Figures 29.

- Unplug the saw.
- Loosen the bevel locking lever by turning it counterclockwise.
- To adjust the bevel angle, turning the height/bevel adjusting handwheel counterclockwise increases the angle of the blade, bringing it closer to 45°; Turning it clockwise decreases the angle, bringing the blade closer to 90°.
- To lock by turning the bevel-locking lever clockwise.

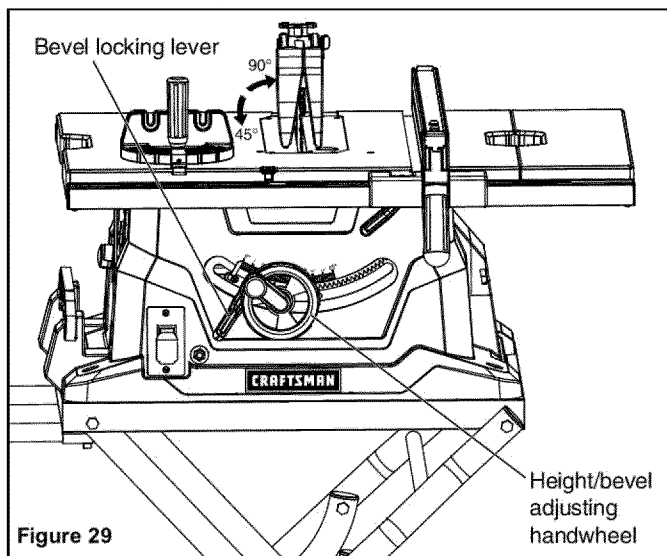

Figure 29

## ADJUSTING THE BEVEL STOPS

Refer to Figures 30-32.

This saw has positive stops that will quickly position the saw blade at 90° or 45° to the table.

The angle settings of the saw have been set at the factory and, unless damaged in shipping, should not require setting during assembly. After extensive use, it may need to be checked.

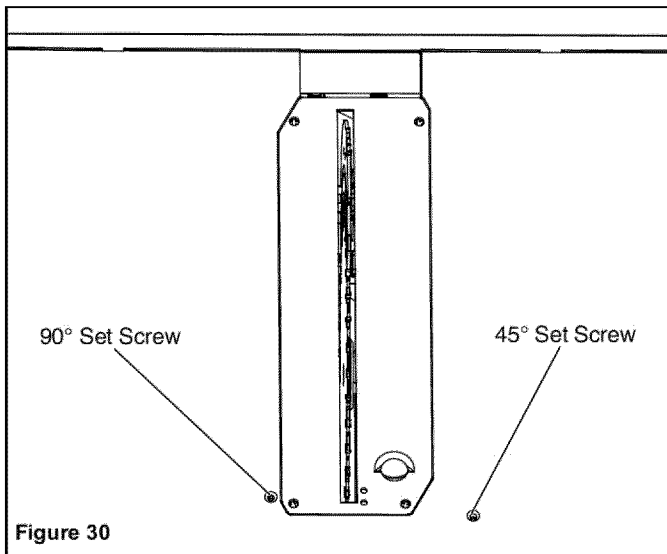

Figure 30

Make adjustments only if necessary.

- Unplug the saw.
- Raise the blade to the maximum height by turning the high adjusting knob clockwise.
- Using a square, set the blade to exactly 90°.
- If the blade stops bevelling before it gets to 90°, loosen the set screw (located in the left of the table insert) with the 3 mm hex wrench (not included), and then adjust it to 90°.
- With the blade set at 90°, slowly turn the 90°-stop set screw until you feel resistance. Bevel the blade away from 90° a little, and then back to the stop.
- Re-measure the angle, and repeat the stop adjustment as necessary until the blade stops at 90°.

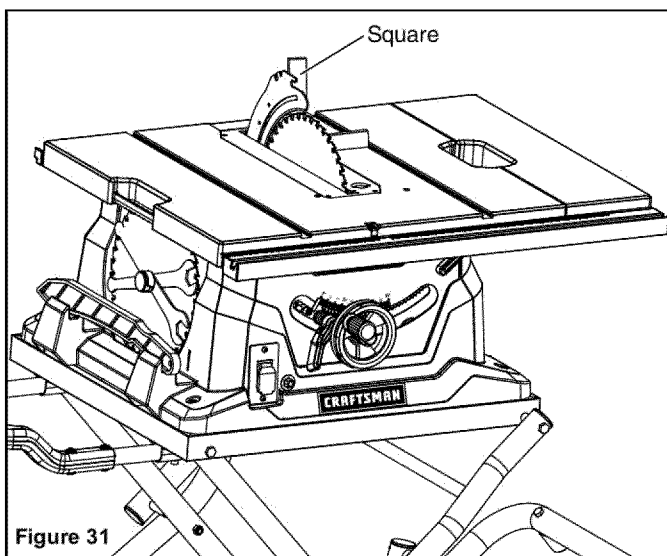

Figure 31

- Set the 45° stop in the same way. The set screw for the 45° stop is located in the right of table insert.

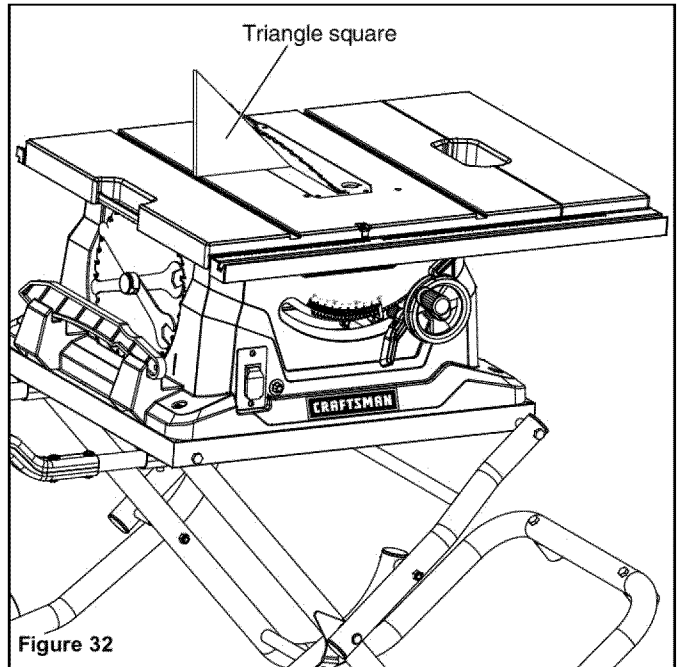

Figure 32

## ADJUSTING THE BEVEL INDICATOR

Refer to Figures 33.

If the bevel indicator is not at 0° when the saw blade is at 90°, adjust the indicator by loosening the cross-screw with a Phillips screwdriver (not included) and setting it to 0° on the bevel scale. Retighten the screw.

**NOTE:** Make a trial cut on a scrap piece of wood before making critical cuts. Measure for exactness.

**CAUTION:** To prevent personal injury:

- Always disconnect the plug from the power source when making any adjustments.
- This adjustment must be correct, or kickback could result in a serious injury and inability to make accurate cuts.

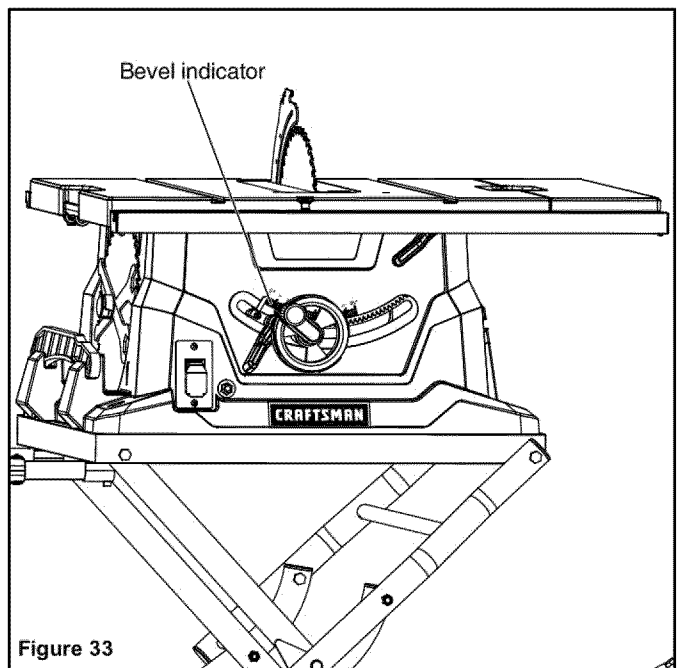

Figure 33

## CHECKING THE ALIGNMENT OF THE RIP FENCE TO THE BLADE

Refer to Figure 34.

- Unplug the saw.
- Remove the blade guard assembly.
- Raise the locking lever to allow the rip fence to be moved.
- Place the framing square beside the blade, and move the rip fence up to the square. Note the measurement on the rip scale.
- Move the fence back, and rotate the framing square 180° to check the other side.
- If the two measurements are not the same, loosen the two M6 x 16 socket head bolts on the fence using a 5 mm hex key (not included), and then align it.
- Retighten the two socket head bolts.
- Make two or three test cuts using scrap wood. If the cuts are not true, repeat the process.

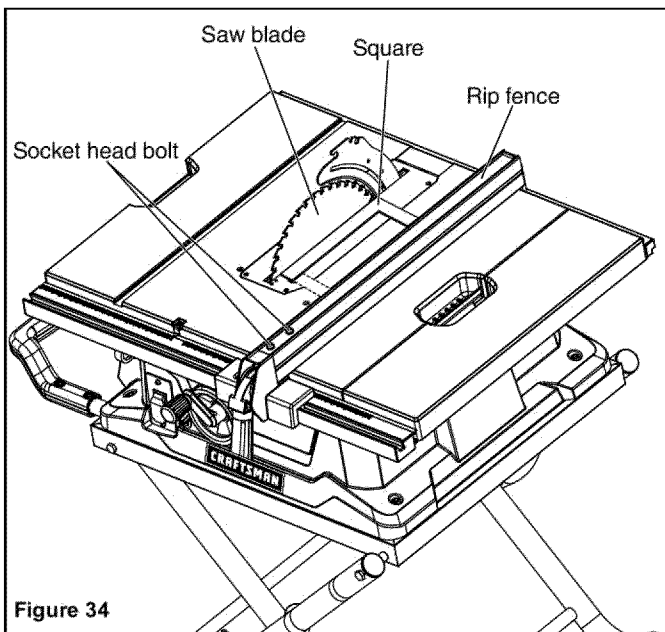

Figure 34

## SETTING THE RIP FENCE SCALE INDICATOR TO THE BLADE

Refer to Figure 35.

Use the indicator on the rip fence to position the fence along the scale on the front rail.

### Begin with the blade at 90° angle (straight up).

- Unplug the saw.
- Loosen the rip fence by lifting the locking lever.
- Place the rip fence on the saw table so that it lightly touches the right side of the saw blade. Lock the rip fence in place.
- Loosen the cross-screw using a Phillips screwdriver (not included) and adjust the indicator so that the red line is located over the "0" line on the front rail of the right-hand rip scale. Retighten the screw.

**NOTE:** The blade guard assembly must be removed to perform this adjustment. Reinstall the blade guard assembly when the adjustment is complete.

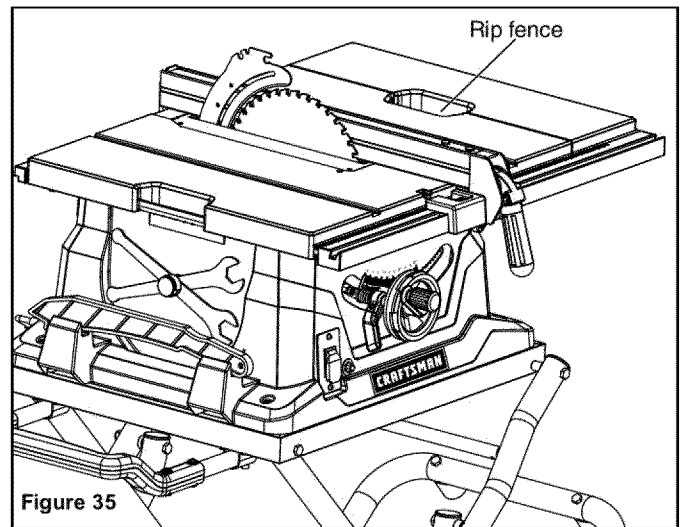

Figure 35

## USING THE RIP FENCE

Refer to Figure 36.

- Unplug the saw.
- Place the rear lip of the rip fence on the rear of the saw table and push it slightly toward the back of the unit.
- Lower the front end of the rip fence onto the guide surfaces on top of the front rail.
- With the rip fence flat on the saw table, push the fence towards the front rail to align the fence to the saw table.
- Push the locking lever down to align and secure the fence.

Check for a smooth gliding action. If adjustments are needed, see the previous section "**Checking the alignment of the rip fence to the blade**".

- Make two or three test cuts using scrap wood. If the cuts are not true, repeat the process.

**NOTE:** The rip fence must be secure when the locking lever is engaged. To increase the grip of the rip fence on the rear lip of the table, tighten the clamp screw on the rear of the rip fence by turn it clockwise.

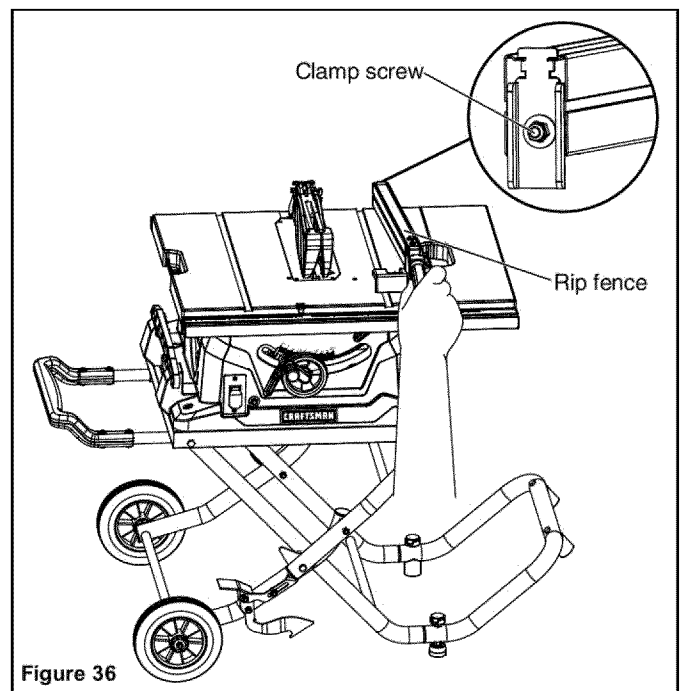

Figure 36



## USING THE MITER GAUGE

Refer to Figures 37-38.

The miter gauge provides greater accuracy in angled cuts. For very close tolerances, test cuts are recommended. There are two miter gauge channels, one on either side of the blade. When making a 90° crosscut, use either miter gauge channel. When making a bevel crosscut (the blade tilted in relation to the table), the miter gauge should be located in the slot on the right so that the blade is tilted away from the miter gauge and away from your hands. The miter gauge can be turned 60° to the right or left. Positive stops at 0°, 22.5° and 45° can be located with rotating the gauge. Face of miter gauge has two holes for purpose of attaching auxiliary facing.

- Slide the miter gauge in the miter gauge slot.
- Loosen the locking knob.
- With the miter gauge in the miter gauge slot, rotate the gauge until the desired angle is reached on the scale.
- Retighten the locking knob.

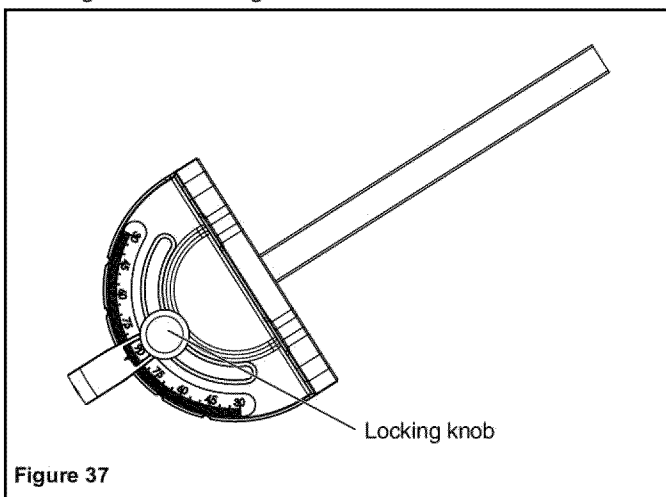

### To adjust miter gauge base:

The miter gauge base should swivel smoothly on the bar after the locking knob is loosened. If adjustment is required:

- Loosen the locking knob
- If the base is too loose, turn the cross-screw in a clockwise direction. If the base is too tight, turn the cross-screw in a counterclockwise direction.

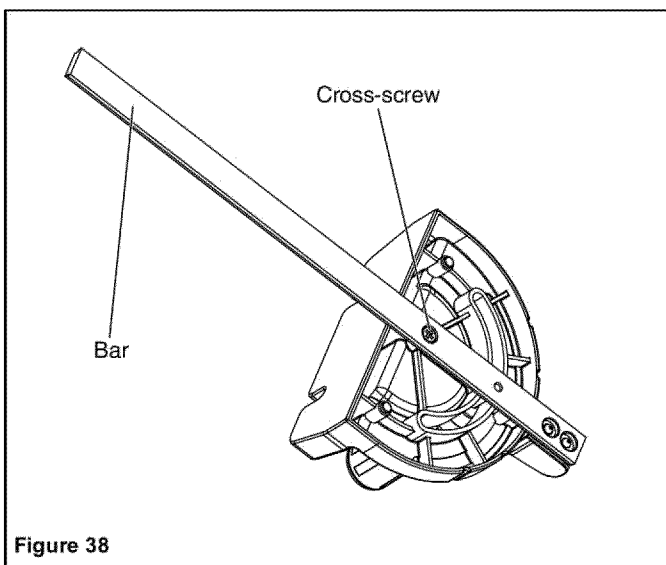

## USING THE SLIDING EXTENSION TABLE

Refer to Figure 39.

Increase the length of the saw table by using the extension table.

- Set the rip fence to 14" (355.6 mm) on the right rail.
- Push the extension-table locking lever to right to unlock the lever.
- Slide the extension table to the desired width.

**NOTE:** Use the scale on the left rail when a specific width is desired.

- Once the extension table is set to the desired width, relock the lever by pulling the lever to left.

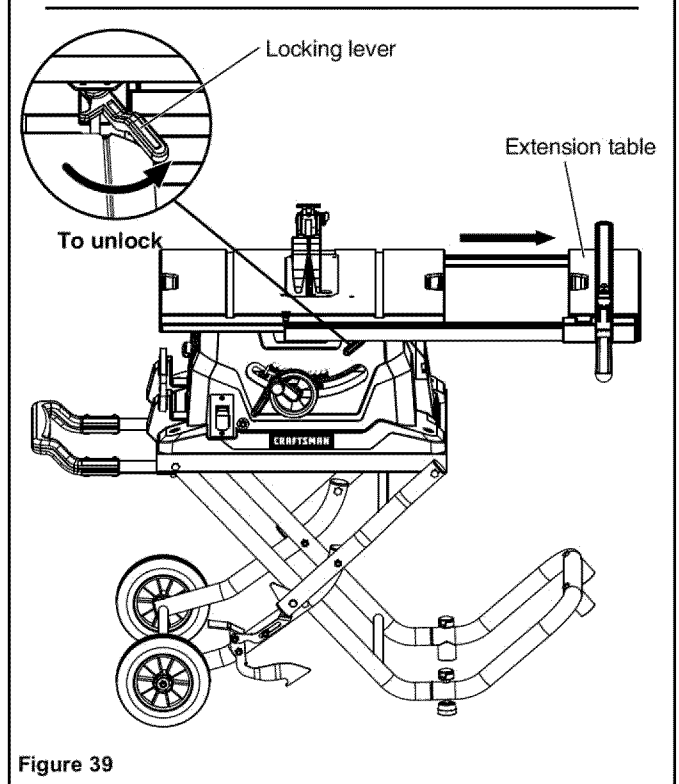
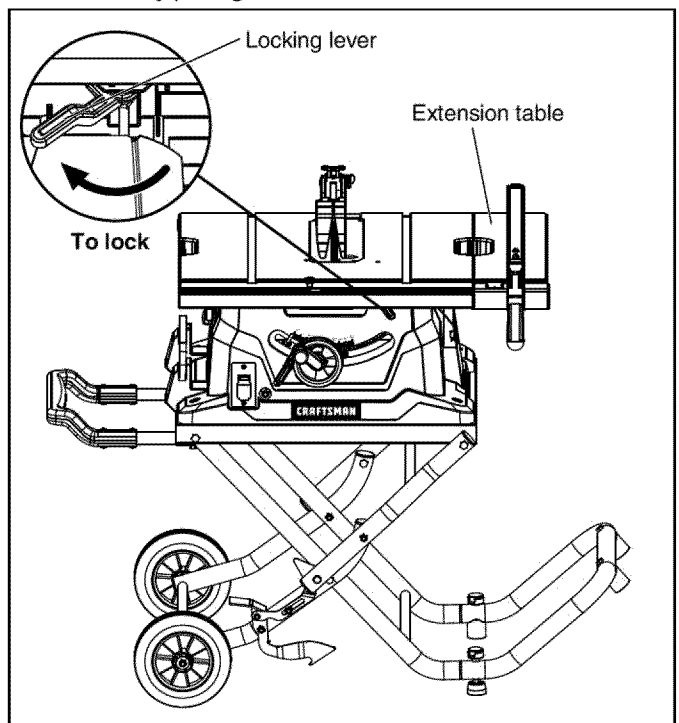

## TO ATTACH DUST EXTRACTION PORT TO SAW

Refer to Figure 40.

Attach the dust extraction port to the pipe located on the back of saw body as shown in illustration below.

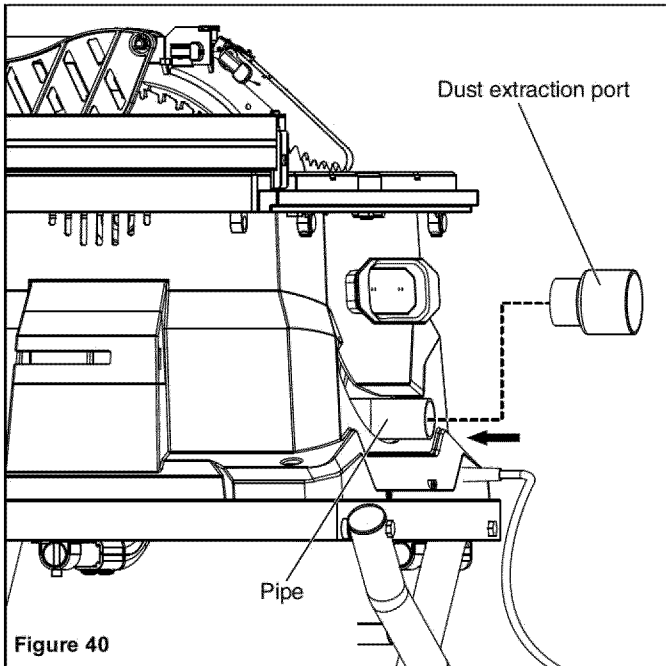

## TO USE DUST EXTRACTION PORT

**WARNING:** To prevent fire hazard, clean and remove sawdust from under the saw frequently.

To prevent sawdust buildup inside the saw housing, for best result, attach a vacuum hose (not included) to the dust extraction port. **DO NOT** operate the saw with hose in place unless the vacuum is turned on.

If the saw is operated without a vacuum attached, some of the dust will be blown out the dust extraction port. After extended use, the saw's dust collection system may become clogged.

## INSTALLATION

Refer to Figures 41-42.

### GROUNDING INSTRUCTIONS

**WARNING:** Improper connection of equipment grounding conductor can result in the risk of electrical shock. Equipment should be grounded while in use to protect operator from electrical shock.

- Check with a qualified electrician if grounding instructions are not understood or if in doubt as to whether the tool is properly grounded.
- This tool is equipped with an approved 3-conductor cord rated at 300V and a 3-prong grounding type plug (see Figure 41) for your protection against shock hazards.
- Grounding plug should be plugged directly into a properly installed and grounded 3-prong grounding-type receptacle, as shown (Figure 41).

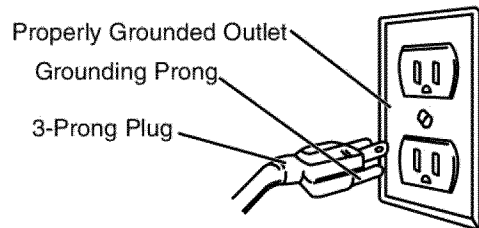

Figure 41 - 3-Prong Receptacle

- Do not remove or alter grounding prong in any manner. In the event of a malfunction or breakdown, grounding provides a path of least resistance for electrical shock.

**WARNING:** Do not permit fingers to touch the terminals of plug when installing or removing from outlet.

- Plug must be plugged into matching outlet that is properly installed and grounded in accordance with all local codes and ordinances. Do not modify plug provided. If it will not fit in outlet, have proper outlet installed by a qualified electrician.
- Inspect tool cords periodically and if damaged, have them repaired by an authorized service facility.
- Green (or green and yellow) conductor in cord is the grounding wire. If repair or replacement of the electric cord or plug is necessary, do not connect the green (or green and yellow) wire to a live terminal.
- Where a 2-prong wall receptacle is encountered, it must be replaced with a properly grounded 3-prong receptacle installed in accordance with National Electric Code and local codes and ordinances.

**WARNING:** This work should be performed by a qualified electrician.

A temporary 3-prong to 2-prong grounding adapter (see Figure 42) is available for connecting plugs to a two pole outlet if it is properly grounded.

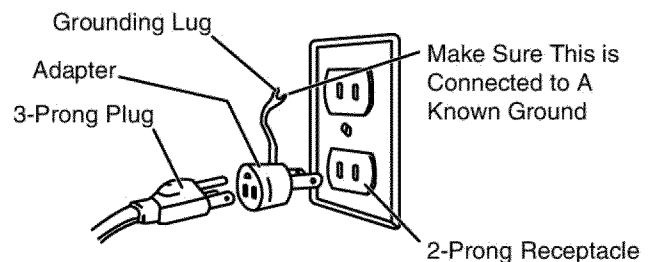

Figure 42 - 2-Prong Receptacle with Adapter

- Do not use a 3-prong to 2-prong grounding adapter unless permitted by local and national codes and ordinances.
- (A 3-prong to 2-prong grounding adapter is not permitted in Canada.) Where permitted, the rigid green tab or terminal on the side of the adapter must be securely connected to a permanent electrical ground such as a properly grounded water pipe, a properly grounded outlet box or a properly grounded wire system.
- Many cover plate screws, water pipes and outlet boxes are not properly grounded. To ensure proper ground, grounding means must be tested by a qualified electrician.

### EXTENSION CORDS

- The use of any extension cord will cause some drop in voltage and loss of power.
- Wires of the extension cord must be of sufficient size to carry the current and maintain adequate voltage.
- Use the table to determine the minimum wire size (A.W.G.)

extension cord.

- Use only 3-wire extension cords having 3-prong grounding type plugs and 3-pole receptacles which accept the tool plug.
- If the extension cord is worn, cut, or damaged in any way, replace it immediately.

#### Extension Cord Length (120V Operation)

	Wire Size A.W.G.
Up to 25 ft. . . . .	14
Up to 50 ft. . . . .	12

**NOTE:** Using extension cords over 50 ft. long is not recommended.

#### Extension Cord Length (240V Operation)

	Wire Size A.W.G.
Up to 50 ft. . . . .	18
50 to 100 ft. . . . .	16
100 to 200 ft. . . . .	14
200 to 300 ft. . . . .	12

**NOTE:** Using extension cords over 300 ft. long is not recommended.

### ELECTRICAL CONNECTIONS

**WARNING:** All electrical connections must be performed by a qualified electrician. Make sure tool is off and disconnected from power source before inspecting any wiring.

The saw is prewired for use on a 120 volt, 60Hz power supply. The power lines are inserted directly onto the switch.

The green ground line must remain securely fastened to the frame to properly protect against electrical shock.

- Remove the key to prevent unauthorized use.

## OPERATION

Refer to Figures 43a-57.

### DESCRIPTION

The Craftsman 10" Model Number 14258 table saw offers precise cutting performance for all woods up to 3<sup>1</sup>/<sub>8</sub>" (8 cm) thick. The saw is designed for the DIYers and is ruggedly constructed for continuous service. The 10" Table Saw is recommended for use with a 10" blade.

The saw features a right extension table with ripping capacity of 24<sup>1</sup>/<sub>2</sub>" (62.2 cm). Saw body has on board storage for push stick, miter gauge, rip fence and saw blades and blade wrenches. Saw is equipped with a riving knife and a clear acrylic blade guard with anti-kickback feature. Cabinet is constructed of plastic and included a dust extraction port.

Rip Fence Assembly features a precision rip fence that is designed for simple and one-hand maneuverability. Front rail is calibrated in inches.

Foldable Leg Stand with wheels features an easy transport and storage.

### SPECIFICATIONS

#### Capacity with 10" Blade:

Depth of cut at 90° . . . . .	3 <sup>1</sup> / <sub>8</sub> " (8 cm)
Maximum tilt angle of arbor (left) . . . . .	45°
Depth of cut at 45° . . . . .	2 <sup>5</sup> / <sub>32</sub> " (5.5 cm)

Max. cut right of blade with rip fence . . . . . 24<sup>1</sup>/<sub>2</sub>" (62.2 cm)

#### Saw Dimensions:

Cabinet depth . . . . .	11 <sup>13</sup> / <sub>32</sub> " (29 cm)
Cabinet width . . . . .	20 <sup>3</sup> / <sub>4</sub> " (52.7 cm)
Cabinet length. . . . .	25 <sup>5</sup> / <sub>32</sub> " (63.9 cm)
Main table size. . . . .	24 x 21 <sup>1</sup> / <sub>16</sub> " (61 x 53.5 cm)
Extension table . . . . .	5 <sup>63</sup> / <sub>64</sub> " x 21 <sup>1</sup> / <sub>16</sub> " (15.2 x 53.5 cm)

#### Saw Blade:

Blade max. capacity. . . . .	10" (25.4 cm)
Blade arbor. . . . .	<sup>5</sup> / <sub>8</sub> " (1.59 cm)
Dado blade max. capacity. . . . .	<sup>1</sup> / <sub>2</sub> " (1.27 cm)

#### Saw Constructions:

Cabinet . . . . .	Plastic
Table . . . . .	Cast aluminum
Rip fence . . . . .	Aluminum extrusion
Drive system . . . . .	By gear
Mitre gauge . . . . .	Cast aluminium with T-rod
Blade guard . . . . .	Acrylic with anti-kickback pawls
Motor . . . . .	120 V, 15 A, 60 Hz
No load speed . . . . .	4500RPM
Net weight with leg stand . . . . .	82.5 lbs (37.5 kg)
Shipping weight. . . . .	94.6 lbs (43 kg)

**WARNING:** Disconnect power before attempting any of the following procedures. Be certain switch is in OFF position and the key is removed. Saw blade must not be moving. Saw blade will rotate freely after motor is turned off. Allow blade to come to a complete stop before attempting any of the following procedures.

**WARNING:** The operation of any power tool can result in foreign objects being thrown into the eyes, which can result in severe eye damage. Always wear safety goggles complying with United States ANSI Z87.1 before commencing power tool operation.

**WARNING:** Do not allow familiarity with a tool to make you careless. Remember that a fraction of a second of carelessness is sufficient to cause serious injury.

**WARNING:** Do not use any attachments or accessories that are not recommended by the manufacturer of this tool. The use of attachments or accessories that are not recommended can result in serious personal injury.

**WARNING:** Although many of the illustrations in this Operator's Manual are shown with the blade guard removed for clarity, do not operate the saw with-out the blade guard unless specifically instructed to do so.

**WARNING:** The table saw must be mounted to a firm, supporting, waist high surface, such as a workbench or leg stand. Many illustrations in this Operator's Manual are shown with the saw unmounted for clarity.

### APPLICATIONS

You can use this tool for the purposes listed below:

- Straight-line cutting operations, such as crosscutting, ripping, mitering, beveling, and compound cutting.
- Dado or molding cuts with optional accessories.
- Cabinet making and woodworking

**NOTE:** This table saw is designed to cut wood and wood composition products only.

## BASIC OPERATION OF THE TABLE SAW

The 3-pronged plug must be plugged into a matching outlet that is properly installed and grounded in compliance with all local codes and ordinances. Improper connection of the equipment can result in electric shock. Check with an electrician or service technician if you are unsure about proper grounding. Do not alter the plug. If it will not fit into the outlet, have the proper outlet installed by a qualified electrician.

## CAUSES OF KICKBACK

Kickback can occur when the blade stalls or binds, causing the workpiece to be kicked back toward the operator with great force and speed. If your hands are near the saw blade, they may be jerked loose from the workpiece and come into contact with the blade. Obviously, kickback can cause serious injury, and it is well worth using precautions to avoid the risks.

Kickback can be caused by any action that pinches the blade in the wood, such as the following:

- Making a cut with incorrect blade depth.
- Sawing into knots or nails in the work piece.
- Twisting the wood while making a cut.
- Failing to support the workpiece.
- Forcing a cut.
- Cutting warped or wet lumber.
- Using the wrong blade for the type of cut.
- Not following correct operating procedures.
- Misusing the saw.
- Failing to use the anti-kickback pawls.
- Cutting with a dull, gummed-up, or improperly set blade.

## AVOIDING KICKBACK

- Always use the correct blade depth setting. The top of the blade teeth should clear the workpiece by  $\frac{1}{8}$ " (3.2 mm) to  $\frac{1}{4}$ " (6.4 mm).
- Inspect the workpiece for knots or nails before beginning a cut. Knock out any loose knots with a hammer. Never saw into a loose knot or nail.
- Always use the rip fence when rip cutting and the miter gauge when crosscutting. This helps to prevent twisting the wood in the cut.
- Always use clean, sharp, and properly set blades. Never make cuts with dull blades.
- To avoid pinching the blade, support the work properly before beginning a cut.
- When making a cut, use steady, even pressure. Never force cuts.
- Do not cut wet or warped lumber.
- Always hold the workpiece firmly with both hands or with push sticks. Keep your body in a balanced position to be ready to resist kickback should it occur. Never stand directly in line with the blade.
- Use the right type of blade for the cut being made.

## PUSH STICK

Refer to Figure 43a-43b.

- Push sticks are devices used for safely pushing a workpiece through the blade instead of using your hands. They can be made from scrap wood in various sizes and shapes to be used in a specific project. The stick must be narrower than the workpiece, with a  $90^\circ$  notch in one end and shaped for a grip on the other end.

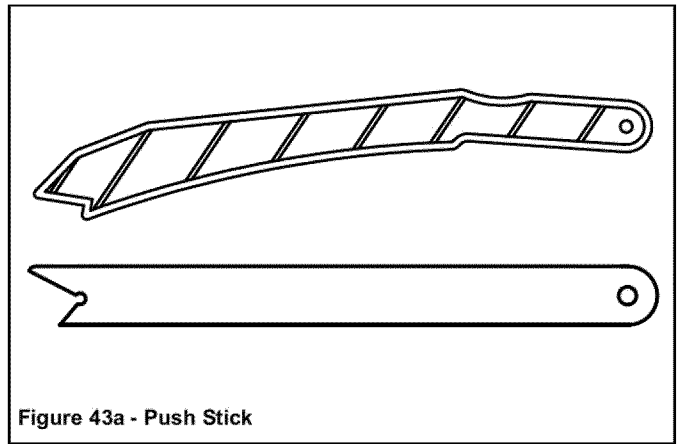

Figure 43a - Push Stick

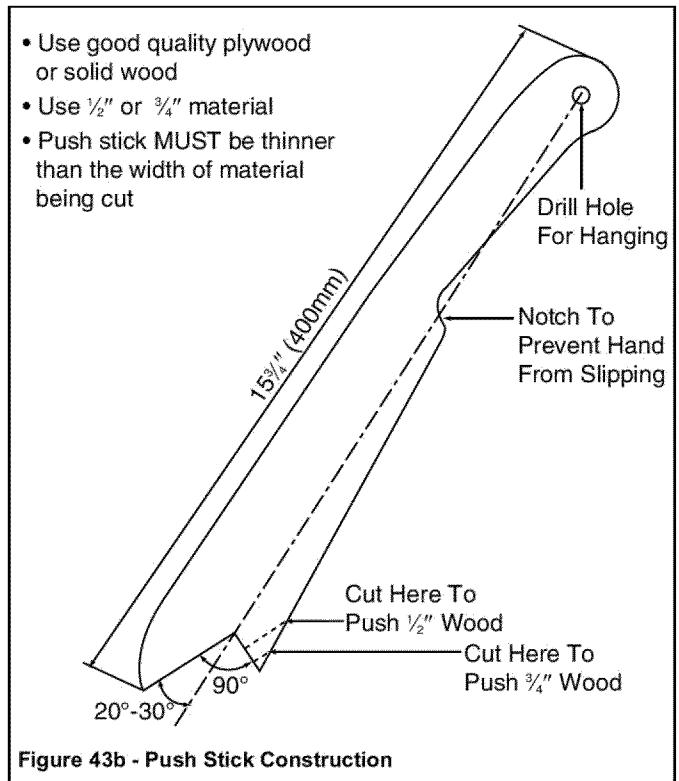

Figure 43b - Push Stick Construction

## PUSH BLOCK

Refer to Figure 44.

- A push block has a handle fastened with recessed screws from the underside. Be sure the screws are recessed. Use it on non-through cuts.

**CAUTION:** Be sure the screws in a push block are recessed to avoid damaging the saw or workpiece.

## How to make a push block

Make a push block using pieces of  $\frac{3}{8}$ " (9.5 mm) plywood and  $\frac{1}{4}$ " (19 mm) hardwood. Position the handle in the center of the plywood, and fasten them together with glue and wood screws. Use a push stick whenever the fence is 2" (5 cm) or more from the blade. Use a push block when the operation is too narrow to allow for the use of a push stick. For proper use, see "BEVEL RIPPING". Either the push stick or block should be used in place of the user's hand to guide the material between the fence and blade. When using a push stick or a push block, the trailing end of the board must be square. A push stick or block against an uneven end could slip off or push the work away from the fence.

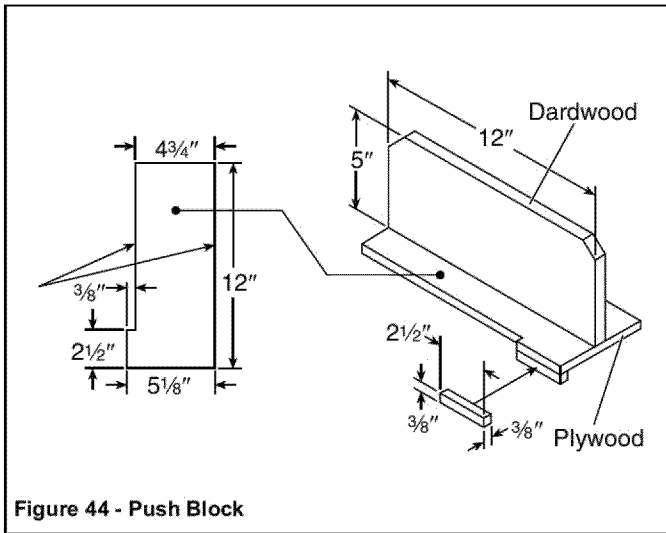

Figure 44 - Push Block

## HOW TO MAKE AND USE THE FEATHERBOARD

Refer to Figures 45-46.

A featherboard is a device used to help control the workpiece by guiding it securely against the table or fence. Featherboards are especially useful when ripping small workpieces and for completing non-through cuts. The end is angled with a number of short kerfs to give a friction hold on the workpiece and locked in place on the table with a C-clamp. Test to ensure it can resist kickback. Place the featherboard against the uncut portion of the workpiece to avoid kickback that could cause serious personal injury.

### To make the featherboard:

The featherboard is an excellent project for the saw.

- Select a solid piece of lumber approximately  $\frac{3}{4}$ " (19 mm) thick,  $3 \frac{5}{8}$ " (9 cm) wide and 18" (45 cm) long.
- Mark the center of the width on one end of the stock.
- Miter one-half of the width to 30°, and miter the other half of the same end to 45° (see "MITER CUTS" for more information).
- Mark the board from the point at 6" (15 cm), 8" (20 cm), 10" (25 cm), and 12" (30 cm). Drill a  $\frac{3}{8}$ " (9.5 mm) hole at the 8" (20 cm), 10" (25 cm), and 12" (30 cm) marks.
- Set the rip fence to allow an approximately  $\frac{1}{4}$ " (6.5 mm) "finger" to be cut in the stock. Feed the stock only to the mark previously made at 6" (15 cm).
- Turn the saw OFF, and allow the blade to completely stop rotating before removing the stock.
- Reset the rip fence, and cut spaced rips into the workpiece to allow approximately  $\frac{1}{4}$ " (6.5 mm) fingers with  $\frac{1}{8}$ " (3 mm) spaces between the fingers.

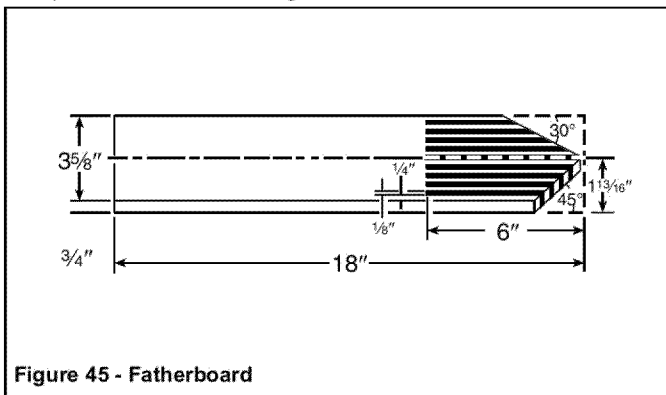

Figure 45 - Featherboard

### To use the featherboard:

- Unplug the saw.
- Completely lower the saw blade.
- Position the rip fence to the desired adjustment for the cut to be performed, and lock the rip fence.
- Place the workpiece against the fence and over the saw blade area.
- Adjust the featherboard to apply resistance to the workpiece just forward of the blade.
- Attach a C-clamp (not supplied) to secure the featherboard to the edge of the saw table.

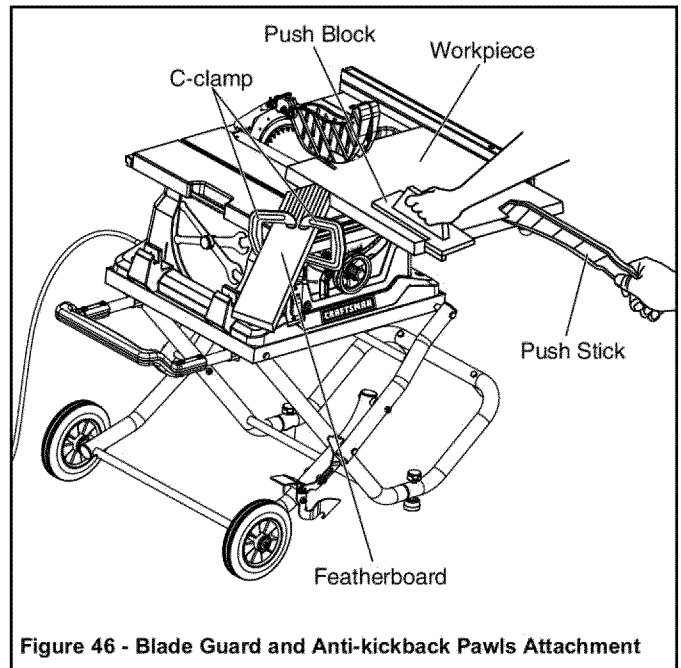

Figure 46 - Blade Guard and Anti-kickback Pawls Attachment

**WARNING: Do not** locate the featherboard to the rear of the workpiece. If positioned improperly, kickback can result from the featherboard pinching the workpiece and binding the blade in the saw kerf. Failure to heed this warning can result in serious personal injury.

### TYPES OF CUTS

Refer to Figure 47.

There are six basic cuts: 1) the cross cut, 2) the rip cut, 3) the miter cut, 4) the bevel cross cut, 5) the bevel rip cut, and, 6) the compound (bevel) miter cut. All other cuts are combinations of these basic six. Operating procedures for making each kind of cut are given later in this section.

**WARNING:** Always make sure the blade guard and anti-kickback pawls are in place and working properly when making these cuts to avoid possible injury.

Cross cuts are straight 90° cuts made across the grain of the workpiece. The wood is fed into the cut at a 90° angle to the blade, and the blade is vertical.

Rip cuts are made with the grain of the wood. To avoid kickback while making a rip cut, make sure one side of the wood rides firmly against the rip fence.

Miter cuts are made with the wood at any angle to the blade other than 90°. The blade is vertical. Miter cuts tend to "creep" during cutting. This can be controlled by holding the workpiece securely against the miter gauge.

**WARNING:** Always use a push stick with small pieces of wood,

and also to finish the cut when ripping a long narrow piece of wood, to prevent your hands from getting close to the blade.

Bevel cuts are made with an angled blade. Bevel cross cuts are across the wood grain, and bevel rip cuts are with the grain. The rip fence must always be on the right side of the blade for bevel rip cuts.

Compound (or bevel) miter cuts are made with an angled blade on wood that is angled to the blade. Be thoroughly familiar with making cross cuts, rip cuts, bevel cuts, and miter cuts before trying a compound miter cut.

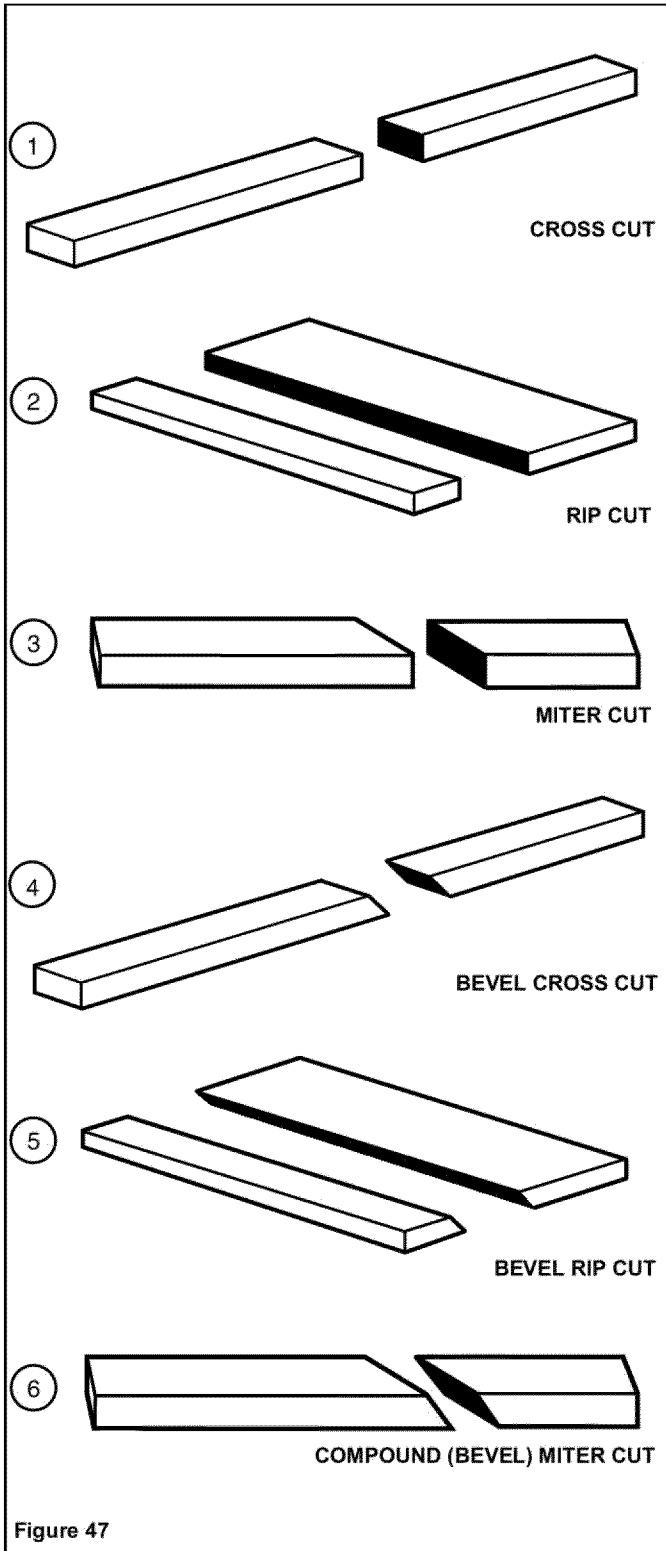

Figure 47

## CUTTING TIPS

Dado and rabbet cuts are non-through cuts which can be either rip cuts or cross cuts. Carefully read and understand all sections of this operator's manual before attempting any operation.

**WARNING:** Do not use blades rated less than the speed of this tool. Failure to heed this warning could result in personal injury.

- The kerf (the cut made by the blade in the wood) will be wider than the blade to avoid overheating or binding. Make allowance for the kerf when measuring wood.
- Make sure the kerf is made on the waste side of the measuring line.
- Cut the wood with the finish side up.
- Knock out any loose knots with a hammer before making the cut.
- Always provide proper support for the wood as it comes out of the saw.

## SWITCH ASSEMBLY

Refer to Figure 48.

This saw is equipped with a switch assembly that has a built-in locking feature. This feature is intended to prevent unauthorized and possibly hazardous use by children and others.

### To turn your saw ON:

With the switch key inserted into the switch, lift the switch to turn it ON.

### To turn your saw OFF:

Press the switch down to turn it OFF.

### To lock your saw:

Press the switch down. Remove the switch key from the switch, and store it in a safe, secure location.

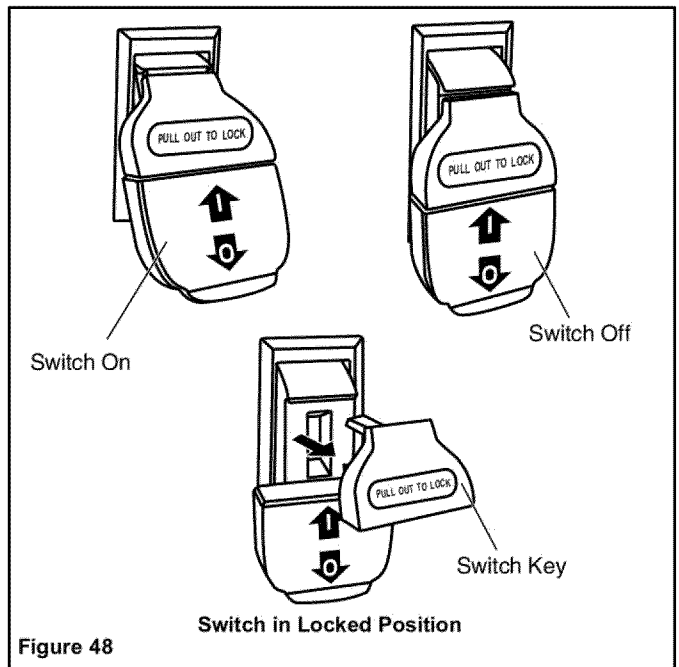

Figure 48

**WARNING:** Always remove the switch key when the tool is not in use, and keep the switch key in a safe place. In the event of a power failure, turn the switch OFF and remove the key. This action will prevent the tool from accidentally starting when the power returns.

**WARNING:** ALWAYS make sure that your workpiece is not in contact with the blade before operating the switch to start the

tool. Failure to heed this warning may cause the workpiece to be kicked back toward the operator, and may result in serious personal injury.

To reduce the risk of accidental starting, always make sure the switch is in the OFF position before plugging the tool into the power source.

### OVERLOAD PROTECTION

The saw is equipped with the overload switch to prevent the saw from overload damage. The saw will stop if the machine was with overloaded cutting or low voltage. Turn the switch to the OFF position and allow the motor to cool down for at least five minutes. And press the overload switch button to resume the overload switch. After the motor has cooled down, turn the switch to the ON position; The saw should now start.

### SAW BLADE

For maximum performance, it is recommended that you use the 10", 5/8" arbor holes and 40-tooth blade provided with your saw. Additional blade styles of the same high quality are available for specific operations such as ripping. Your local dealer can provide you with complete information.

**WARNING:** Do not use blades rated less than the speed of this tool. Failure to heed this warning could result in personal injury.

**WARNING:** To prevent possible electrical hazards, have a qualified electrician check the line if you are not certain that it is properly wired.

### MAKING CUTS

The blade provided with the saw is a high-quality combination blade suitable for ripping and cross cut operations.

**WARNING:** Do not use blades rated less than the speed of this tool. Failure to heed this warning could result in personal injury.

Use the miter gauge when making cross, miter, bevel, and compound miter cuts. To secure the angle, lock the miter gauge in place by twisting the lock knob clockwise. Always tighten the lock knob securely in place before use.

**NOTE:** It is recommended that you place the piece to be saved on the left side of the blade and that you make a test cut on scrap wood first.

### MAKING A CROSS CUT

Refer to Figure 49.

It is recommended you make test cuts on scrap wood.

**WARNING:** Using the rip fence as a cutoff gauge when cross cutting will result in kickback which can cause serious personal injury.

**WARNING:** Make sure the blade guard assembly is installed and working properly to avoid serious personal injury.

- Remove the rip fence by lifting the locking lever.
- Set the blade to the correct depth for the workpiece.
- Set the miter gauge to 0° and tighten the lock knob.
- Place a support (the same height as saw table) behind the saw for the cut work.
- Make sure the wood is clear of the blade before turning on the saw.
- To turn the saw **ON**, lift the switch.
- To turn saw **OFF**, press the switch down.

**NOTE:** To prevent unauthorized use, remove the switch key as shown in figure 48.

- Let the blade build up to full speed before moving the workpiece into the blade.

- Hold the workpiece firmly with both hands and feed the workpiece into the blade.

**NOTE:** The hand closest to the blade should be placed on the miter gauge lock knob and the hand farthest from the blade should be placed on the workpiece.

- When the cut is made, turn the saw off. Wait for the blade to come to a complete stop before removing any part of the workpiece.

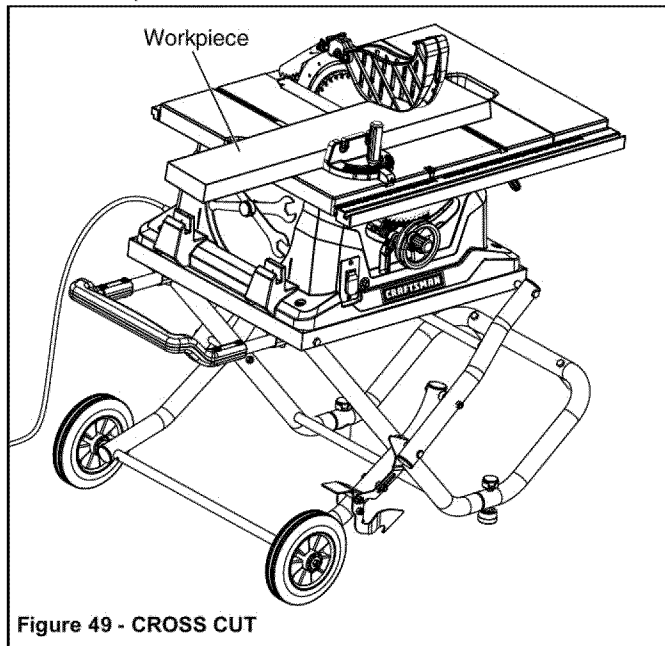

Figure 49 - CROSS CUT

### MAKING A RIP CUT

Refer to Figures 50.

It is recommended you make test cuts on scrap wood.

**WARNING:** Make sure the blade guard assembly is installed and working properly to avoid serious personal injury.

- Remove the miter gauge by sliding it out of the miter gauge groove.
- Set the blade to the correct depth for the workpiece.
- Set the blade to 0°.
- Position the rip fence the desired distance from the blade for the cut and securely lock the handle.
- Place a support (the same height as the saw table) behind the table saw for the cut work.
- Make sure the wood is clear of the blade before turning on the table saw.
- Use a push block or push stick to move the wood through the cut past the blade. **Never push a small piece of wood into the blade with your hand. Always use a push stick.** The use of push blocks, push sticks, and featherboards are necessary when making non-through cuts.
- Stand to the side of the wood as it contacts the blade to reduce the chance of injury should kickback occur. **Never stand directly in the line of cut.**
- Make sure the wood is clear of the blade before turning on the table saw.
- Let the blade build up to full speed before feeding the workpiece into the blade.
- When the cut is made, turn the saw off. Wait for the blade to come to a complete stop before removing any part of the workpiece.

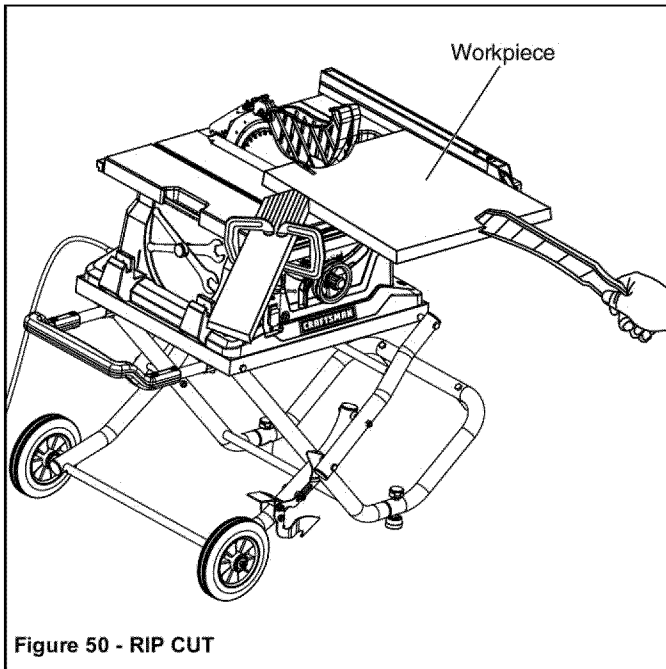

Figure 50 - RIP CUT

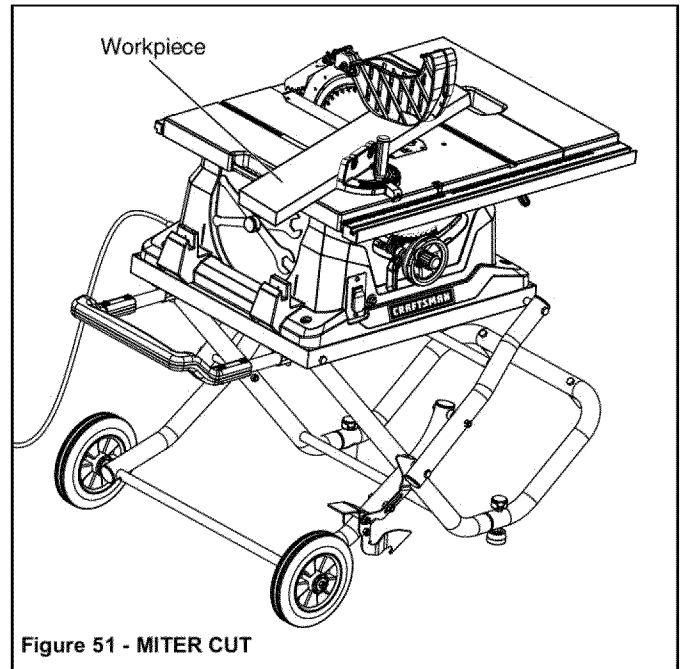

Figure 51 - MITER CUT

### MAKING A MITER CUT

Refer to Figure 51.

It is recommended you make test cuts on scrap wood.

**WARNING:** Make sure the blade guard assembly is installed and working properly to avoid serious personal injury.

- Remove the rip fence by lifting the locking lever.
- Set the blade to the correct depth for the workpiece.
- Set the miter gauge to desired angle and tighten the lock knob.
- Place a support (the same height as saw table) behind the saw for the cut work.
- Make sure the wood is clear of the blade before turning on the saw.
- Let the blade build up to full speed before moving the workpiece into the blade.
- Hold the workpiece firmly with both hands and feed the workpiece into the blade.

**NOTE:** The hand closest to the blade should be placed on the miter gauge lock knob and the hand farthest from the blade should be placed on the workpiece.

- When the cut is made, turn the saw off. Wait for the blade to come to a complete stop before removing any part of the workpiece.

**CAUTION:** The miter gauge cannot be used in the left miter gauge groove when bevel cutting due to blade guard interference. Only use the miter gauge in the right miter gauge groove when bevel cutting.

### MAKING A BEVEL CROSS CUT

Refer to Figure 52.

It is recommended that you place the piece to be saved on the left side of the blade and that you make a test cut on scrap wood.

**WARNING:** Make sure the blade guard assembly is installed and working properly to avoid serious personal injury.

- Remove the rip fence by lifting the locking lever.
- Unlock the bevel locking lever and move height/bevel adjusting handwheel until bevel indicator is at desired angle.
- Relock the bevel locking lever.
- Set the blade to the correct depth for the workpiece.
- Set miter gauge to 0° and tighten the lock knob.
- Place a support (the same height as saw table) behind the saw for the cut work.
- Make sure the wood is clear of the blade before turning on the saw.
- Let the saw blade build up to full speed before moving the miter gauge and the workpiece into the blade.
- Hold the workpiece firmly with both hands and feed the workpiece into the blade.

**NOTE:** The hand closest to the blade should be placed on the miter gauge lock knob and the hand farthest from the blade should be placed on the workpiece.

- When the cut is made, turn the saw off. Wait for the blade to come to a complete stop before removing any part of the workpiece.



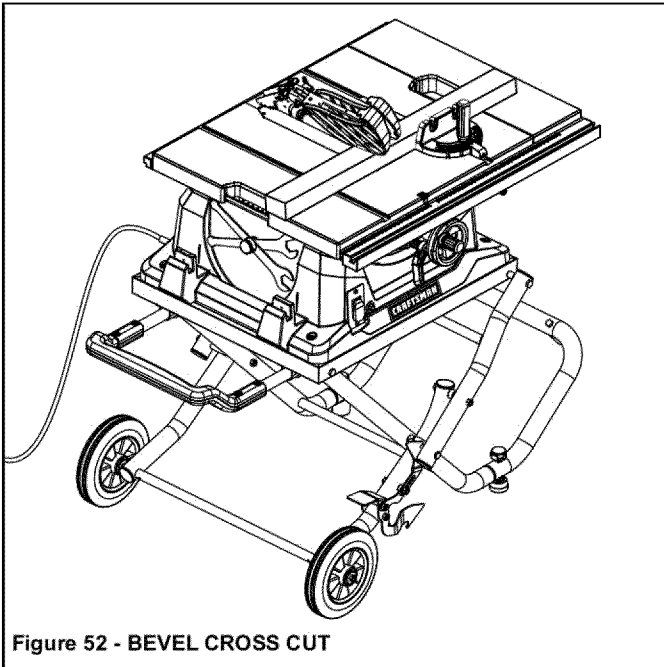

Figure 52 - BEVEL CROSS CUT

### MAKING A BEVEL RIP CUT

Refer to Figure 53.

It is recommended you make test cuts on scrap wood.

**WARNING:** The rip fence must be on the right side of the blade to avoid trapping the wood and causing kickback. Placement of the rip fence to the left of the blade will result in kickback and the risk of serious personal injury.

**WARNING:** Make sure the blade guard assembly is installed and working properly to avoid serious personal injury.

- Unlock the bevel locking lever and move height/bevel adjusting handwheel until bevel indicator is at desired angle.
- Relock the bevel locking lever.
- Set the blade to the correct depth for the workpiece.
- Position the rip fence the desired distance from the right side of the blade and lock down the lever.
- If ripping a larger piece, place a support the same height as the table surface behind the saw for the cut work.
- Make sure the wood is clear of the blade before turning on the saw.
- Position the workpiece flat on the table with the edge flush against the rip fence. Let the blade build up to full speed before feeding the workpiece into the blade.
- Using a push stick and/or push blocks, slowly feed the workpiece toward the blade. Stand slightly to the side of the wood as it contacts the blade to reduce the chance of injury should kickback occur.
- Once the blade has made contact with the workpiece, use the hand closest to the rip fence to guide it. Make sure the edge of the workpiece remains in solid contact with both the rip fence and the surface of the table. If ripping a narrow piece, use a push stick to move the piece through the cut and past the blade.
- When the cut is made, turn the saw off. Wait for the blade to come to a complete stop before removing any part of the workpiece.
- After the blade has stopped completely, remove the cutoff stock.

- Grasp the workpiece from the lead end (the end fed into the blade first) and carefully remove it from the saw table.

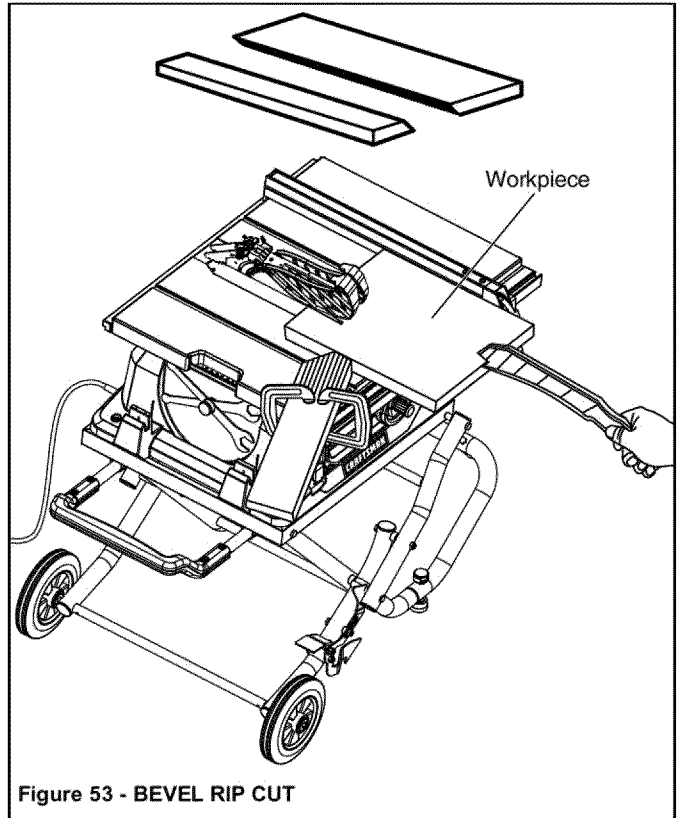

Figure 53 - BEVEL RIP CUT

### MAKING A COMPOUND (BEVEL) MITER CUT

Refer to Figure 54.

It is recommended that you place the piece to be saved on the left side of the blade and that you make a test cut on scrap wood.

**WARNING:** Make sure the blade guard assembly is installed and working properly to avoid serious personal injury.

- Remove the rip fence by lifting the locking lever.
- Unlock the bevel locking lever and move height/bevel adjusting handwheel until bevel indicator is at desired angle.
- Push the bevel locking lever toward the table to relock it.
- Set the blade to the correct depth for the workpiece.
- Set the miter gauge to desired angle and tighten the lock knob.
- Make sure the wood is clear of the blade before turning **ON** the saw.
- Hold the workpiece firmly with both hands and feed the workpiece into the blade.

**NOTE:** The hand closest to the blade should be placed on the miter gauge lock knob and the hand farthest from the blade should be placed on the workpiece.

- Advance the workpiece and the miter gauge toward the blade. Keep the workpiece flush against the miter gauge. Stand slightly to the side of the wood as it contacts the blade to reduce the chance of injury should kickback occur.
- When the cut is made, turn the saw **OFF**. Wait for the blade to come to a complete stop before removing any part of the workpiece.
- After the blade has stopped completely, remove the cutoff stock.

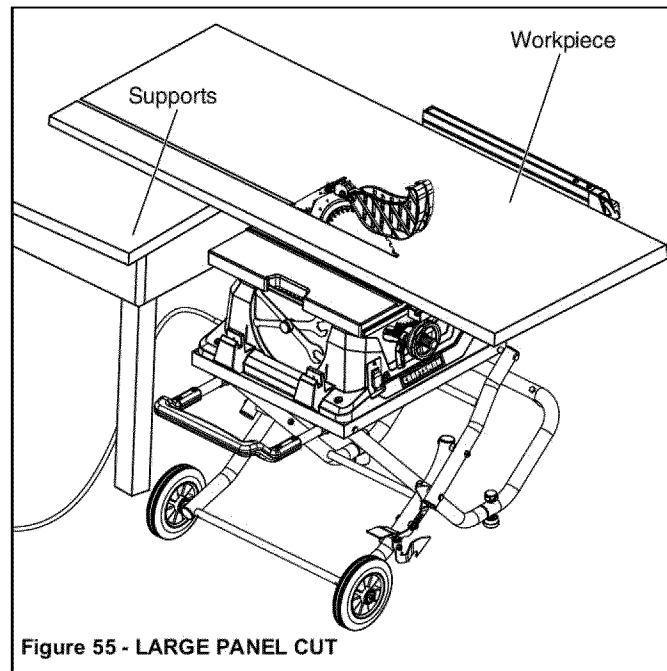
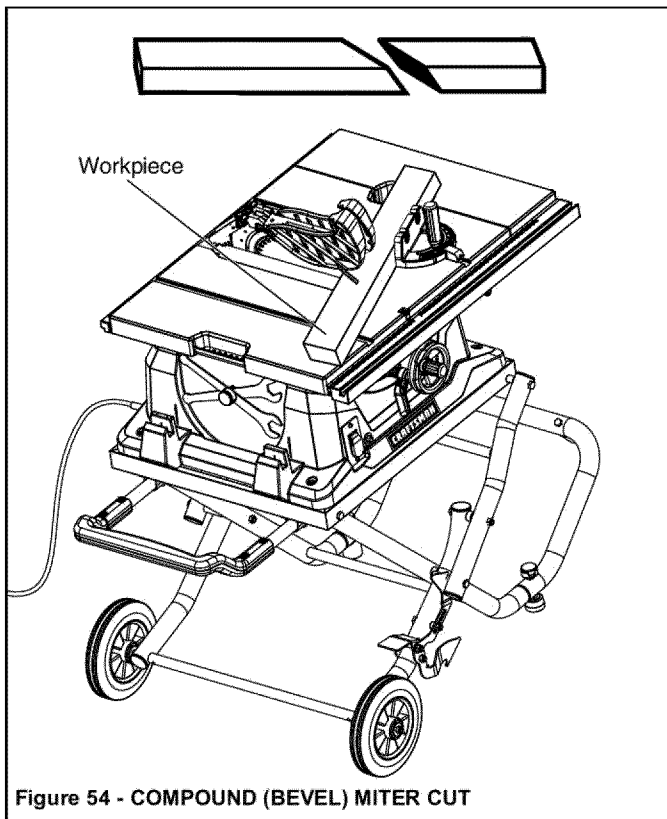

### MAKING A LARGE PANEL CUT

Refer to Figure 55.

Make sure the saw is properly secured to a work surface to avoid tipping from the weight of a large panel.

**WARNING:** Make sure the blade guard assembly is installed and working properly to avoid serious personal injury.

- Place a support the same height as the top of the saw table behind the saw for the cut work. Add supports to the sides as needed.
- Depending on the shape of the panel, use the rip fence or miter gauge. If the panel is too large to use either the rip fence or the miter gauge, it is too large for this saw.

**WARNING:** Never make freehand cuts (cuts without the miter gauge or rip fence). Such a cut increases the risk of kickback and can result in serious injury.

Make sure the wood is clear of the blade before turning on the saw.

- Let the blade build up to full speed before moving the workpiece into the blade.
- Hold the workpiece firmly and feed the workpiece into the blade.
- When the cut is made, turn the saw off. Wait for the blade to come to a complete stop before removing any part of the workpiece.
- After the blade has stopped completely, remove the cutoff stock.

### MAKING A NON-THROUGH CUT

Refer to Figure 56.

Non-through cuts can be made with the grain (ripping) or across the grain (cross cut). The use of a non-through cut is essential to cutting grooves, rabbets, and dados. **DO NOT** perform bevel non-through cuts on this machine.

**NOTE:** This is the only type of cut that is made without the blade guard assembly installed. Make sure the blade guard assembly is reinstalled upon completion of this type of cut.

Read the appropriate section which describes the type of cut in addition to this section on non-through or dado cuts. For example, if your non-through cut is a straight cross cut, read and understand the section on straight cross cuts before proceeding.

**WARNING:** When making a non-through cut, the cutter is covered by the workpiece during most of the cut. Be alert to the exposed cutter at the start and finish of every cut to avoid the risk of serious personal injury.

**WARNING:** Never feed wood with your hands when making any non-through cut such as rabbets. To avoid personal injury, always use push blocks, push sticks, and featherboards.

- Unplug the saw.
- Remove the blade guard assembly and anti-kickback pawls assembly.
- Unlock the release lever.
- Set the riving knife in the middle position.
- Relock the release lever.
- Set the blade to 0°.
- Set the blade to the correct depth for the workpiece.
- Plug the saw into the power source.
- Turn the saw **ON**.
- Feed the workpiece into the blade.

**NOTE:** Always use push blocks, push sticks, and featherboards when making non-through cuts to avoid the risk of serious injury.

- When the cut is made, turn the saw off. Wait for the blade to come to a complete stop before removing any part of the workpiece.

Once all non-through cuts are complete:

- Unplug the saw.
- Raise the blade and reinstall the blade guard assembly and anti-kickback pawls assembly.

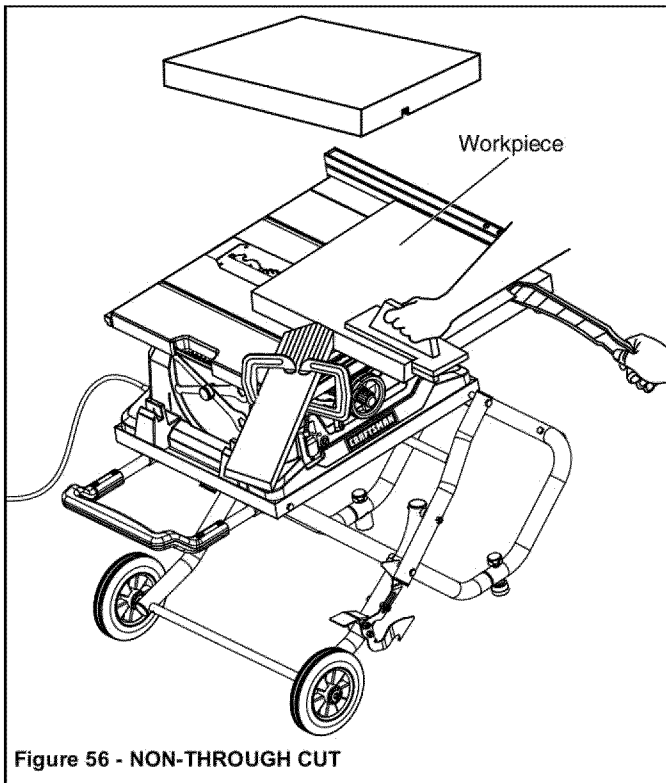

## DADO CUTTING

Refer to Figure 57.

The dado table insert included is required for this procedure. Blades and dado sets must not be rated lower than the speed of this tool. This saw is designed for use with an 6" (152 cm) stack dado up to 1/2" (12.7 mm) wide. Do not use an adjustable dado with this saw.

**WARNING:** This saw cannot be used to make a bevel dado cut.

- Unplug the saw.
- Remove the blade guard, anti-kickback pawls and table insert.
- Remove the arbor nut, blade outer flange saw blade.
- Mount the dado blade, using the appropriate blade and chippers for the desired width of cut.
- Reinstall the outer flange and the arbor nut.

**NOTE:** Make sure the arbor nut is fully engaged and the arbor extends past a securely tightened arbor nut.

- Place the riving knife in the lowest position.
- Place the release lever in the locked position.
- Install the dado table insert, rotate the blade by hand to make sure it turns freely, and then lower the blade.
- Plug the saw into the power source and turn it on.
- Position the workpiece flat on the table, with the edge flush against the rip fence or miter gauge.
- Use a push block or push stick to move the wood through the cut past the blade. Never push a small piece of wood into the blade using your hand. Always use a push stick and featherboard.

**WARNING:** Always use push blocks, push sticks, or featherboards when making dado cuts to avoid the risk of serious injury.

- After the cut is made, turn the saw off. Wait for the blade to come to a complete stop before removing the workpiece.

**NOTE:** When cutting with a dado blade, use a dust collection system to prevent heavy dust loads from piling up under the saw and on the fan intake on the motor. Clean these areas often.

**WARNING:** Always put all spacers in proper location when changing back to saw blade. Failure to do so may result in possible injury and damage to the tool.

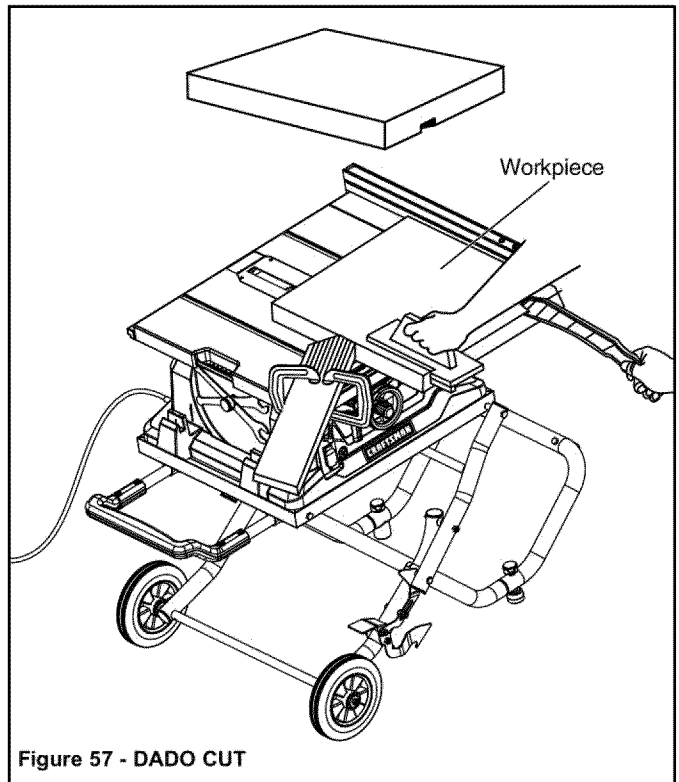

## MAINTENANCE

**WARNING:** Do not attempt under any circumstances, to service, repair, dismantle, or disassemble any mechanical or electrical components without physically disconnecting all power sources.

### GENERAL MAINTENANCE

Avoid using solvents when cleaning plastic parts. Most plastics are susceptible to damage from various types of commercial solvents. Use clean cloths to remove dirt, dust, oil, grease, etc. Do not allow brake fluid, gasoline, petroleum-based products, penetrating oils, etc., to come into contact with plastic parts. Chemicals can damage, weaken or destroy plastic, which may result in serious personal in-jury.

- Periodically check all clamps, nuts, bolts, and screws for tightness and condition. Make sure that the throat plate is in good condition and in the proper position.
- Check the blade guard assembly.
- Clean blades using a gum and pitch remover.
- To maintain the table surfaces and rails, periodically apply paste wax to them and buff them to ensure smooth functioning. To prevent work from slipping during cutting operations, DO NOT wax the working face of the miter gauge.
- Protect the saw blade by cleaning sawdust out from under the saw table and between the blade teeth. Use a resin

solvent on the blade teeth. Do not use gasoline!

- Clean plastic parts only with a soft damp cloth. Do not use any aerosol or petroleum solvents.

## LUBRICATION

- This saw's motor bearings have been packed at the factory with proper lubrication.
- Clean screw threads and nuts using a solvent recommended for gum and pitch removal.
- Lubricate screw threads, nuts, and bearing points (including those on the blade guard assembly and the miter gauge).

## SERVICE

- Replace worn parts as needed. If power cords are worn, cut, or damaged in any way, have them replaced immediately.
- Make sure teeth of anti-kickback pawls are always sharp.
- Sharpen dull teeth using a few light strokes of a smooth cut flat file.

## TO REPLACE THE BLADE

Refer to Figures 58-59.

When you need replace the saw blade, please follow the procedure as following:

- Unplug the saw.
- Unscrew red knob on side of saw to remove blade wrenches from storage area.
- Remove blade guard assembly and pawl assembly.
- Turn height adjustment hand wheel counterclockwise to drop the saw blade to lowest position, and remove the table insert.
- Turn hand wheel clockwise to raise blade to maximum height.
- Using one opened-ended blade wrench, place the flat open end on the flats on the inner blade flange.
- Using the other opened-ended blade wrench, place the flat open end on the flats on the arbor nut. Holding both wrenches firmly, pull the opened-ended blade wrench on the arbor nut forward to the front of the machine.

**WARNING:** Be extremely careful when loosening arbor nut. Keep firm grasp on both wrenches. Do not allow hands to slip and contact blade.

- Raise the riving knife locking lever to upright position.
- Remove arbor nut, outer blade flange and saw blade.
- Place one new blade on arbor. Make sure saw blade teeth point down at the front side of saw table. Place outer flange and nut on arbor and use blade wrenches to tighten nut securely.
- Push the riving knife locking lever back to locked position.
- Lower the saw blade to lowest position and replace table insert.
- Replace blade guard assembly and pawl assembly.

**NOTE:** Blade may be stored on the side of the saw in the same storage area provided for the blade wrenches.

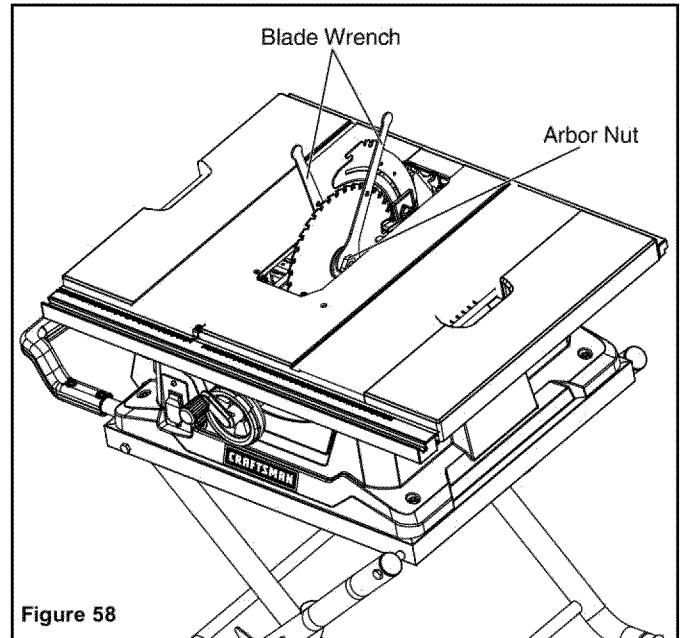

Figure 58

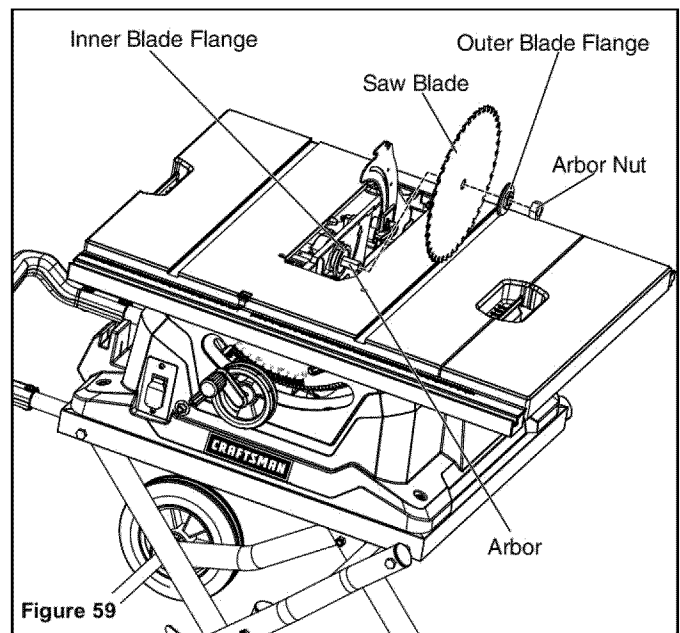

Figure 59

## BRUSH REPLACEMENT

Refer to Figure 63.

- Unplug the saw.
- Lower blade completely and bevel to 45°. Lock the blade.
- Turn saw upside down.
- Remove brush caps with a screwdriver.

**NOTE:** Brush assembly is spring load and will pop out when brush cap is removed.

- Remove brush assemblies and check for wear.
- Replace both brushes when either has less than 1/4" length of carbon remaining. **Do not** replace one side without replacing the other.
- Reassemble using new brush assemblies by reversing the steps listed above. Make sure curvature of brush matches curvature of motor and that brush moves freely in brush tube.
- Tighten all brush caps securely. **Do not** overtighten.

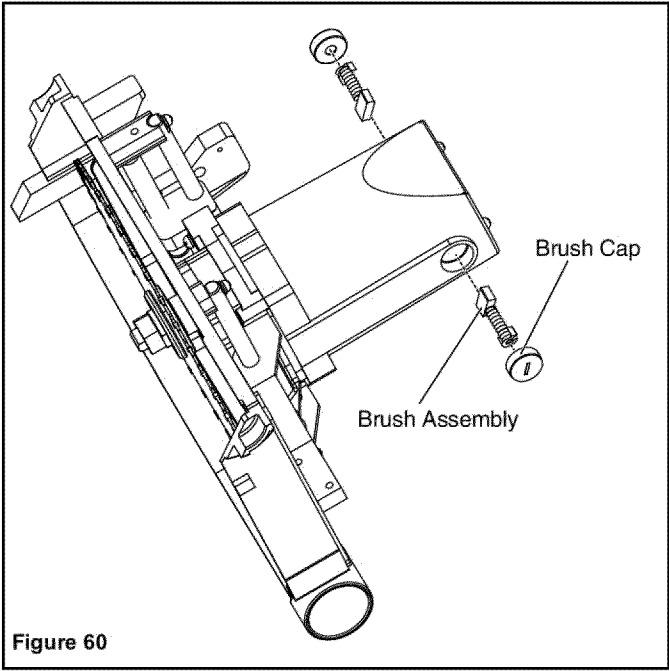

Figure 60



## TROUBLESHOOTING

SYMPTOM	POSSIBLE CAUSE(S)	CORRECTIVE ACTION
Saw will not start	<ol style="list-style-type: none"> <li>1. Overload tripped</li> <li>2. Saw is not plugged in</li> <li>3. Fuse blown or circuit breaker tripped</li> <li>4. Cord is damaged</li> </ol>	<ol style="list-style-type: none"> <li>1. Allow motor to cool and reset by pushing reset switch</li> <li>2. Plug in saw</li> <li>3. Replace fuse or reset circuit breaker</li> <li>4. Have the cord replaced by a qualified electrician</li> </ol>
Does not make 45° and 90° rip cuts	<ol style="list-style-type: none"> <li>1. Positive stop not adjusted correctly</li> <li>2. Bevel angle pointer not set accurately</li> <li>3. Rip fence not be properly aligned</li> </ol>	<ol style="list-style-type: none"> <li>1. Check blade with square and adjust positive stop</li> <li>2. Check blade with square and adjust to zero</li> <li>3. Align the rip fence with the mitre gauge slot</li> </ol>
Material pinched blade when ripping	<ol style="list-style-type: none"> <li>1. Rip fence not aligned with blade</li> <li>2. Warped wood, edge against fence is not straight</li> </ol>	<ol style="list-style-type: none"> <li>1. Check and adjust rip fence</li> <li>2. Select another piece of wood</li> </ol>
Material binds on riving knife	<ol style="list-style-type: none"> <li>1. Riving knife not aligned correctly with blade</li> </ol>	<ol style="list-style-type: none"> <li>1. Check and align riving knife with blade</li> </ol>
Saw makes unsatisfactory cuts	<ol style="list-style-type: none"> <li>1. Dull blade</li> <li>2. Blade mounted backwards</li> <li>3. Gum or pitch on blade</li> <li>4. Incorrect blade for work being done</li> <li>5. Gum or pitch on blade causing erratic feed</li> </ol>	<ol style="list-style-type: none"> <li>1. Replace blade</li> <li>2. Turn the blade around</li> <li>3. Remove the blade and clean with turpentine and coarse steel wool</li> <li>4. Change the blade</li> <li>5. Clean table with turpentine and steel wool</li> </ol>
Material kicked back from blade	<ol style="list-style-type: none"> <li>1. Rip fence out of adjustment</li> <li>2. Riving knife not aligned with blade</li> <li>3. Feeding stock without rip fence</li> <li>4. Riving knife not in place</li> <li>5. Dull blade</li> <li>6. The operator letting go of material before it is past saw blade</li> <li>7. Miter angle lock knob is not tight</li> </ol>	<ol style="list-style-type: none"> <li>1. Align rip fence with miter gauge slot</li> <li>2. Align riving knife with blade</li> <li>3. Install and use rip fence</li> <li>4. Install and use riving knife (with guard)</li> <li>5. Replace blade</li> <li>6. Push material all the way past saw blade before releasing work</li> <li>7. Tighten knob</li> </ol>
Blade does not raise or tilt freely	<ol style="list-style-type: none"> <li>1. Sawdust and dirt in elevation/tilting mechanisms</li> </ol>	<ol style="list-style-type: none"> <li>1. Brush or blow out loose dust and dirt</li> </ol>
Blade does not come up to speed Reset trips too easily	<ol style="list-style-type: none"> <li>1. Extension cord too light or too long</li> <li>2. Low house voltage</li> </ol>	<ol style="list-style-type: none"> <li>1. Replace with adequate size cord</li> <li>2. Contact your electric company</li> </ol>
Machine vibrates excessively	<ol style="list-style-type: none"> <li>1. The saw is not mounted securely to the stand</li> <li>2. Stand on uneven floor</li> <li>3. Stand is not balanced</li> <li>4. Damaged saw blade</li> </ol>	<ol style="list-style-type: none"> <li>1. Tighten all mounting hardware</li> <li>2. Reposition on flat level surface</li> <li>3. Adjust the leveling foot</li> <li>4. Replace blade</li> </ol>
Does not make accurate 45° and 90°	<ol style="list-style-type: none"> <li>1. Miter gauge out of adjustment</li> </ol>	<ol style="list-style-type: none"> <li>1. Adjust miter gauge</li> </ol>

## Repair Protection Agreements

*Congratulations on making a smart purchase.* Your new Craftsman® product is designed and manufactured for years of dependable operation. But like all products, it may require repair from time to time. That's when having a Repair Protection Agreement can save you money and aggravation.

### Here's what the Repair Protection Agreement\* includes:

- ☑ **Expert service** by our 10,000 professional repair specialists
- ☑ **Unlimited service and no charge** for parts and labor on all covered repairs
- ☑ **Product replacement** up to \$1500 if your covered product can't be fixed
- ☑ **Discount of 25%** from regular price of service and related installed parts not covered by the agreement; also 25% off regular price of preventive maintenance check.
- ☑ **Fast help by phone** – we call it Rapid Resolution – phone support from a Sears representative. Think of us as a “talking owner's manual.”

Once you purchase the Repair Protection Agreement, a simple phone call is all that it takes for you to schedule service. You can call anytime day or night, or schedule a service appointment online.

The Repair Protection Agreement is a risk-free purchase. If you cancel for any reason during the product warranty period, we will provide a full refund. Or, a prorated refund anytime after the product warranty period expires. Purchase your Repair Protection Agreement today!

**Some limitations and exclusions apply. For prices and additional information in the U.S.A. call 1-800-827-6655. \*Coverage in Canada varies on some items. For full details call Sears Canada at 1-800-361-6665.**

### Sears Installation Service

*For Sears professional installation* of home appliances, garage door openers, water heaters, and other major home items, in the U.S.A. or Canada call **1-888-331-4569**.



Model 141.142580

Figure 61 - Replacement Parts Illustration for Rip Fence

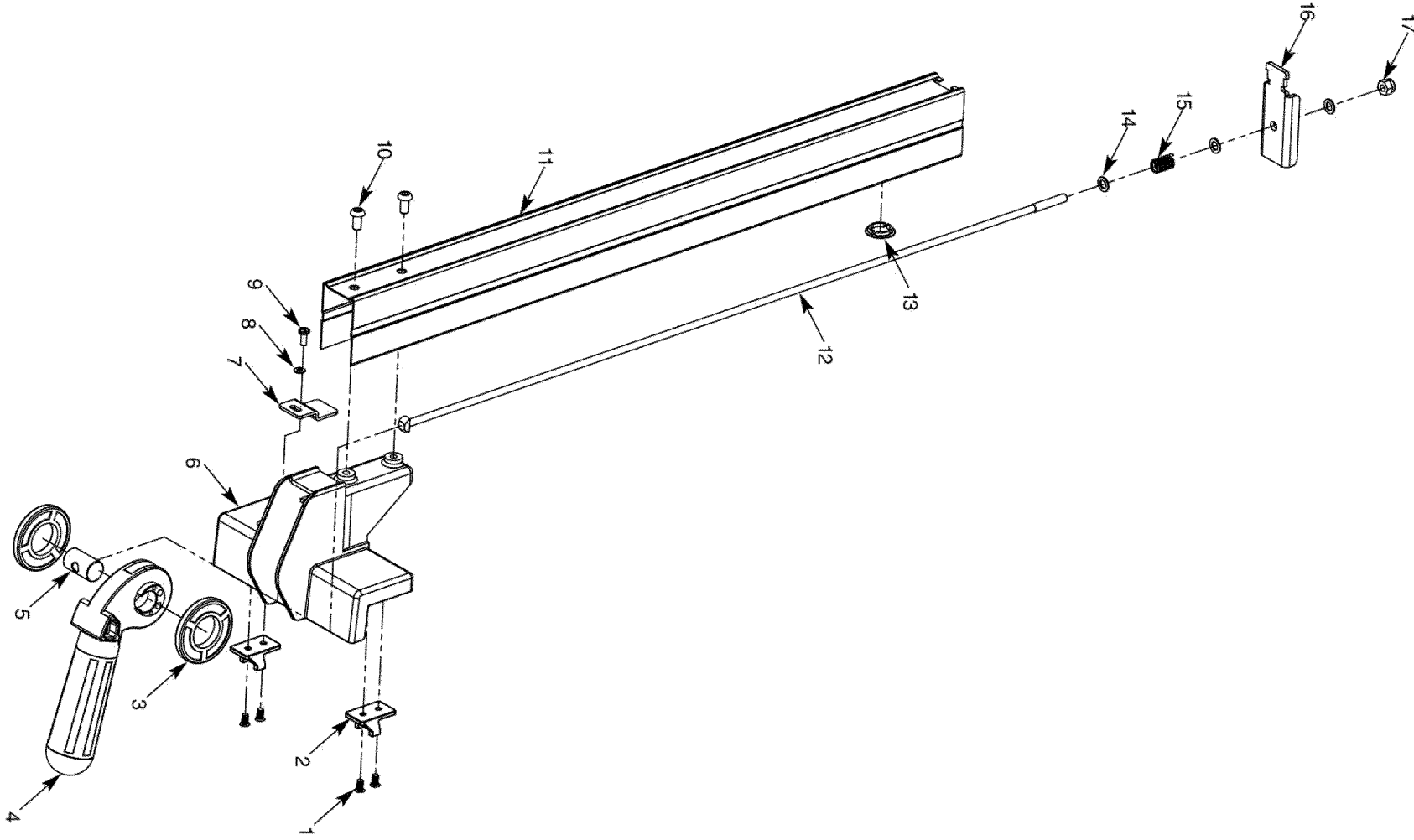

## REPLACEMENT PARTS LIST FOR RIP FENCE

KEY			
NO.	PART NO.	DESCRIPTION	QTY.
1	142580.001	Cross Recessed Countersunk Head Screw M4x8	4
2	142580.002	Pressure Pad	2
3	142580.003	Clamping Ring	2
4	142580.004	Eccentric Clamp Lever	1
5	142580.005	Forcing Spindle	1
6	142580.006	Fixed Seat	1
7	142580.007	Pointer	1
8	142580.008	Flat Washer 4	1
9	142580.009	Cross Recess Pan Head Screw M4x10	1
10	142580.010	Hexagon Socket Button Head Screws M6x12	2
11	142580.011	Fence	1
12	142580.012	Locking Thread Rod	1
13	142580.013	Friction Pad	1
14	142580.014	Flat Washer 6	3
15	142580.015	Compression Spring	1
16	142580.016	Locking plate	1
17	142580.017	Hexagon lock nut M6	1

# Model 141.142580

## Figure 62 - Replacement Parts Illustration for Cabinet

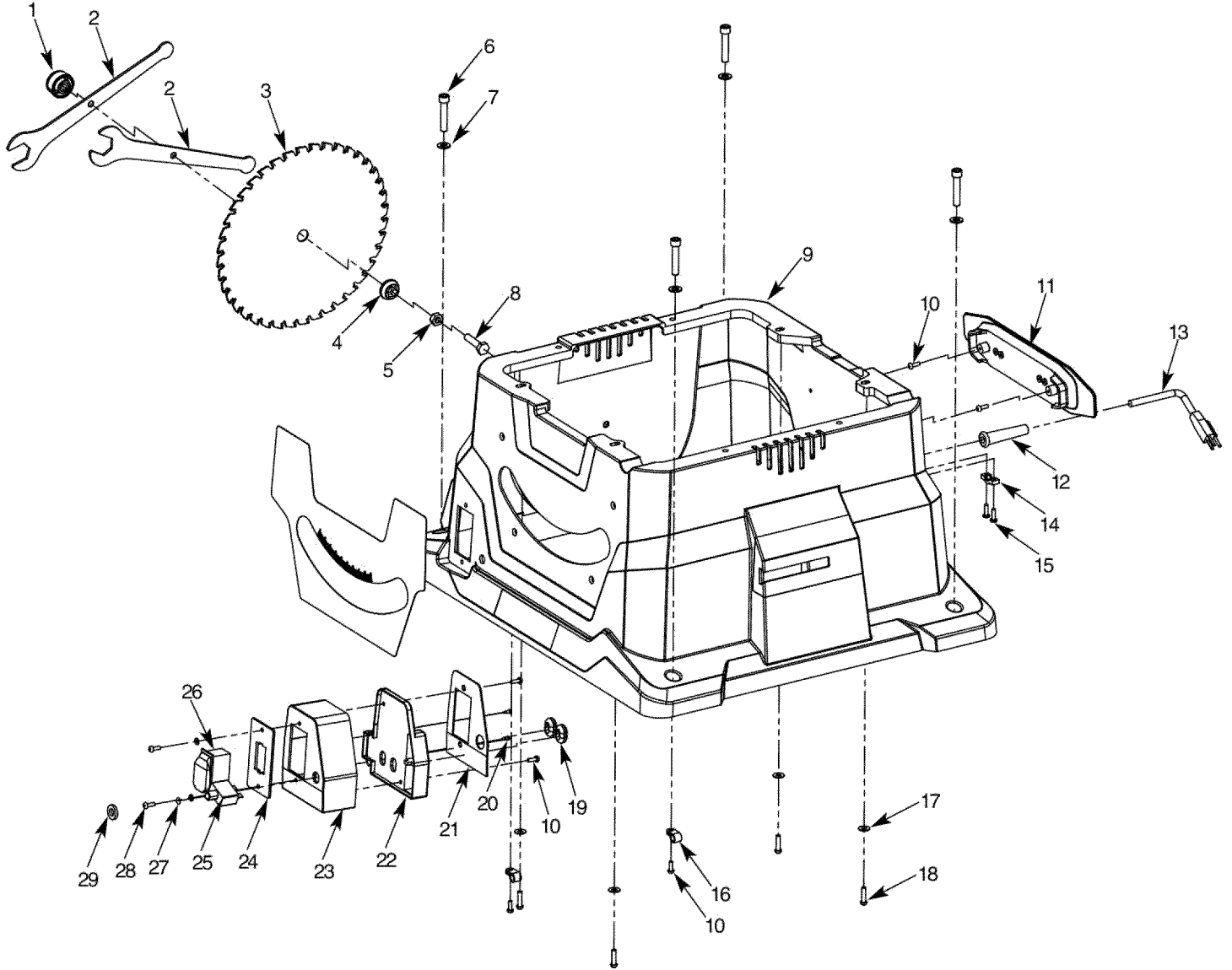

## REPLACEMENT PARTS LIST FOR CABINET

KEY			
NO.	PART NO.	DESCRIPTION	QTY.
1	142580.018	Blade Knob	1
2	142580.019	Blade Wrench	2
3	142580.020	Blade	1
4	142580.021	Lock Sleeve	1
5	142580.022	Hex Nut M8	1
6	142580.023	Hexagon Socket Cap Screws M8x35	4
7	142580.024	Flat Washer 8	4
8	142580.025	Hexagon Bolt M8x35	1
9	142580.026	Saw Cabinet	1
10	142580.027	Cross Trough Pan Head Self-drilling Screw ST4.2x12	6
11	142580.028	Power Cord Storage	1
12	142580.029	Sheath	1
13	142580.030	Power Cord 14AWG	1
14	142580.031	Line Clamp	1
15	142580.032	Cross Trough Pan Head Self-drilling Screw ST4.2x16	2
16	142580.033	Fastener	2
17	142580.034	Big Flat Washer 5	4
18	142580.035	Cross Recess Pan Head Screw M5x20	4
19	142580.036	Protective Ring	2
20	142580.037	Cross Trough Pan Head Self-drilling Screw ST2.9x9	2
21	142580.038	Base Plate	1
22	142580.039	Switch Box Cover	1
23	142580.040	Junction Box	1
24	142580.041	Switch Plate	1
25	142580.042	Overload Protector 15A	1
26	142580.043	Switch	1
27	142580.044	Flat Washer 4	2
28	142580.045	Cross Recess Pan Head Screw M4x12	2
29	142580.046	Nut	1

Model 141.142580

Figure 63 - Replacement Parts Illustration for Rail

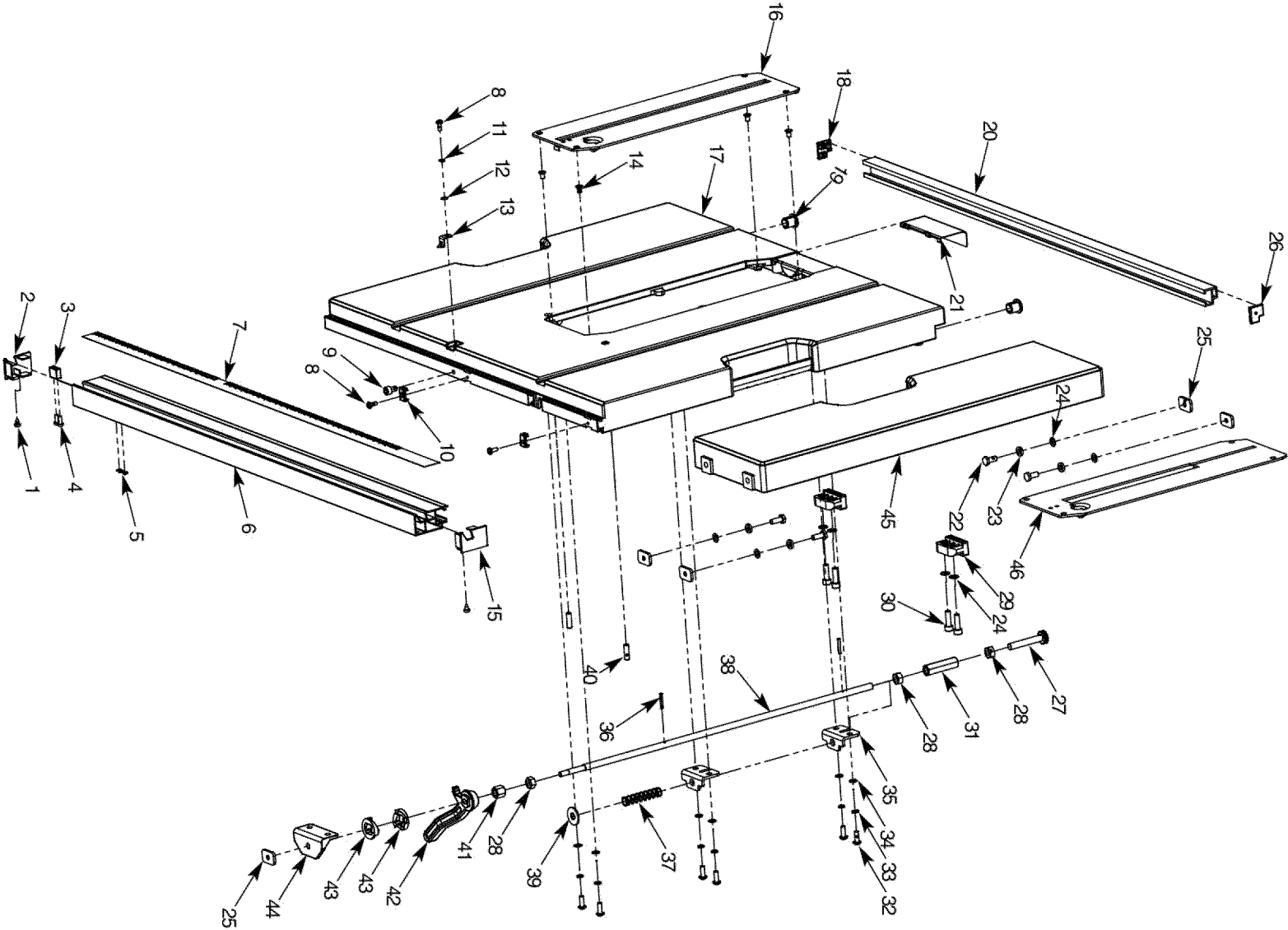

## REPLACEMENT PARTS LIST FOR RAIL

KEY			
NO.	PART NO.	DESCRIPTION	QTY.
1	14258.047	Cross Trough Pan Head Self-drilling Screw ST3.5×13	2
2	14258.048	End Cap (A)	1
3	14258.049	Stop block (B)	1
4	14258.050	Cross Trough Pan Head Self-drilling Screw ST3.5×10	2
5	14258.051	Friction Pad A	1
6	14258.052	Main Rail	1
7	14258.053	Scale Label	1
8	14258.054	Cross Recess Pan Head Screw M4	2
9	14258.055	Hexagon Socket Cap Screws M6	1
10	14258.056	Friction Pad C	2
11	14258.057	Spring Washer 4	1
12	14258.058	Flat Washer 4	1
13	14258.059	Pointer	1
14	14258.060	Cross Recessed Countersunk Head Screw M5×8	4
15	14258.061	End Cap (B)	1
16	14258.062	Table Insert	1
17	14258.063	Main Worktable	1
18	14258.064	End Cap for Rear Rail (A)	1
19	14258.065	End Cap for Rear Extension	2
20	14258.066	Rear Rail	1
21	14258.067	Base Plate	1
22	14258.068	Hexagon Bolt M6×16	4
23	14258.069	Spring Washer 6	4
24	14258.070	Flat Washer 6	5
25	14258.071	Stop Block (A)	5
26	14258.072	End Cap for Rear Rail (B)	1
27	14258.073	Knurl Screw	1
28	14258.074	Hex Nut M8	3
29	14258.075	Fixed Plate	2
30	14258.076	Hexagon Socket Cap Screws M6×20	4
31	14258.077	Longer Nut (A)	1
32	14258.078	Cross Recess Pan Head Screw M5×12	6
33	14258.079	Spring Washer 5	6
34	14258.080	Flat Washer 5	6
35	14258.081	Retain Plate (B)	2
36	14258.082	Spring Column Pin 3×20	2
37	14258.083	Locking Rod Spring	1
38	14258.084	Locking Rod	1
39	14258.085	Big Flat Washer 8	1
40	14258.086	Allen Flat End Set Screws M6×20	2
41	14258.087	Longer Nut (B)	1
42	14258.088	Locking Lever	1
43	14258.089	Locking Block	2
44	14258.090	Retain Plate (A)	1
45	14258.091	Side Extension Table	1
46	14258.092	Dado Insert	1

Figure 64 - Replacement Parts Illustration for Blade Driver

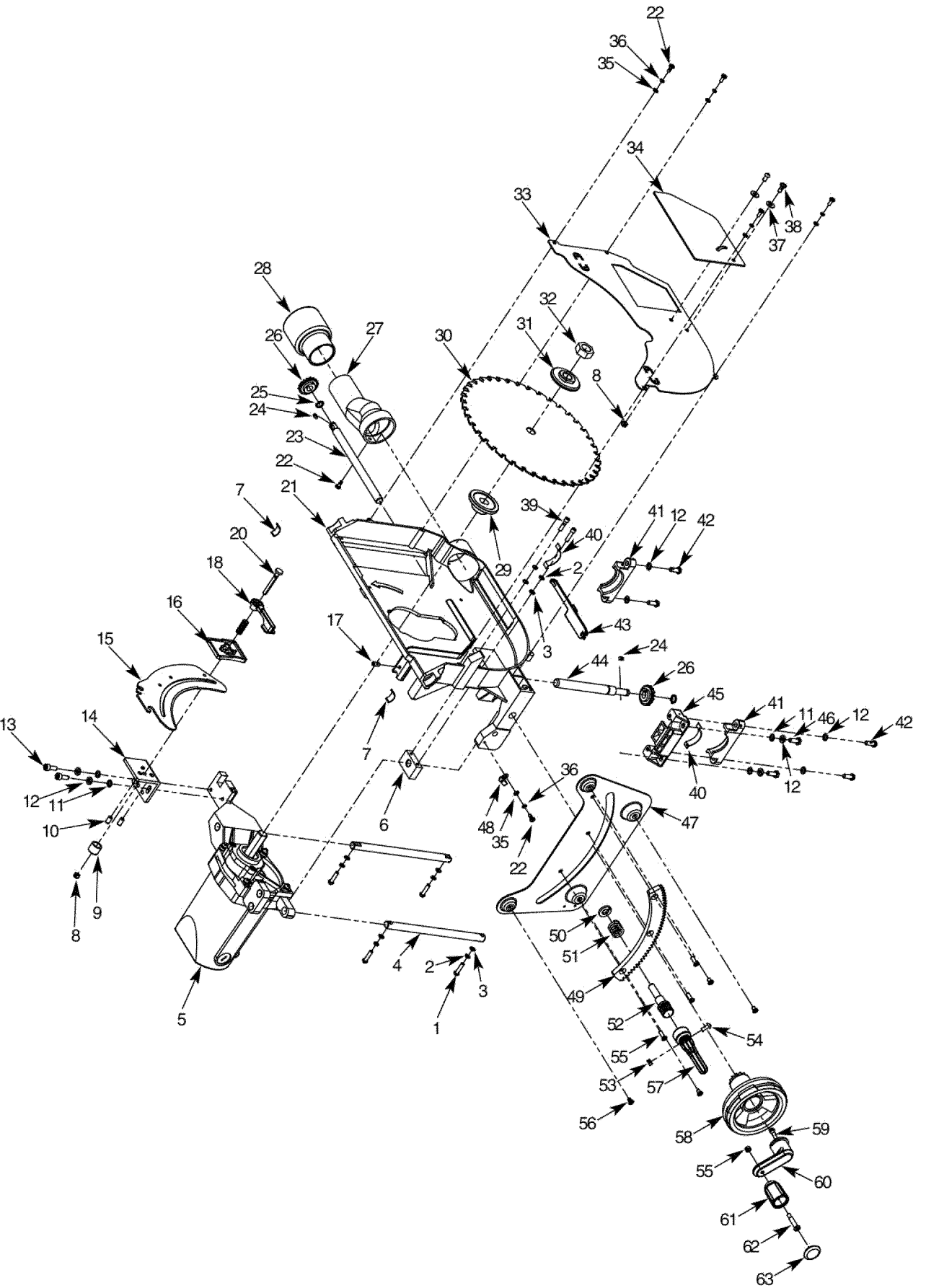

## REPLACEMENT PARTS LIST FOR BLADE DRIVER

KEY			
NO.	PART NO.	DESCRIPTION	QTY.
1	142580.093	Cross Recess Pan Head Screw M5x20	4
2	142580.094	Spring Washer 5	6
3	142580.095	Flat Washer 5	6
4	142580.096	Guide Post	2
5	142580.097	Motor	1
6	142580.098	Adjusting Seat	1
7	142580.099	Spacer	2
8	142580.100	Hexagon Lock Nut M5	2
9	142580.101	Pressing Sleeve	1
10	142580.102	Locating Pin	2
11	142580.103	Flat Washer 6	8
12	142580.104	Spring Washer 6	4
13	142580.105	Hexagon Socket Cap Screw M6x16	2
14	142580.106	Riving Knife Holder	1
15	142580.107	Riving Knife	1
16	142580.108	Pressing Plate	1
17	142580.109	Compression Spring	1
18	142580.110	Clamp Lever	1
19	142580.111	Allen Flat End Set Screw M6x12	1
20	142580.112	Bolt	1
21	142580.113	Trunion	1
22	142580.114	Cross Recess Pan Head Screw M4x10	6
23	142580.115	Adjusting Rod (A)	1
24	142580.116	Flat Key 4x8	2
25	142580.117	Retainer Ring 10	2
26	142580.118	Bevel Gear	2
27	142580.119	Dust Adaptor	1
28	142580.120	Dust Port	1
29	142580.121	Inner Flange	1
30	142580.020	Blade	1
31	142580.122	Outer Flange	1
32	142580.123	Nut M16	1
33	142580.124	Baffle Plate	1

KEY			
NO.	PART NO.	DESCRIPTION	QTY.
34	142580.125	Small baffle	1
35	142580.126	Flat Washer 4	5
36	142580.127	Spring Washer 4	5
37	142580.128	Big Flat Washer 5	1
38	142580.129	Cross Recess Pan Head Screw M5x12	1
39	142580.130	Hexagon Socket Cap Screw M5x20	2
40	142580.131	Gliding Sheet	2
41	142580.132	Fixed Seat (A)	2
42	142580.133	Cross Recess Pan Head Screw M6x16	4
43	142580.134	Lower Baffle	1
44	142580.135	Adjustable Lever (B)	1
45	142580.136	Fixed Seat (B)	1
46	142580.137	Hexagon Bolt M6x16	2
47	142580.138	Strengthen Plate	1
48	142580.139	Pointer	1
49	142580.140	Rack (B)	1
50	142580.141	Spacer	1
51	142580.142	Spring	1
52	142580.143	Threaded Rod	1
53	142580.144	Hex Nut M5	3
54	142580.145	Cross Recess Pan Head Screw M5x12	1
55	142580.146	Cross Recessed Countersunk Head Screw M5x16	2
56	142580.147	Cross Recessed Countersunk Head Screw M5x8	4
57	142580.148	Locking Handle	1
58	142580.149	Rotation Wheel	1
59	142580.150	Cross Recess Pan Head Screw M5x16	1
60	142580.151	Handlebar	1
61	142580.152	Rotation Knob	1
62	142580.153	Bolt	1
63	142580.154	End Cover	1



# Model 141.142580

## Figure 65 - Replacement Parts Illustration for Stand

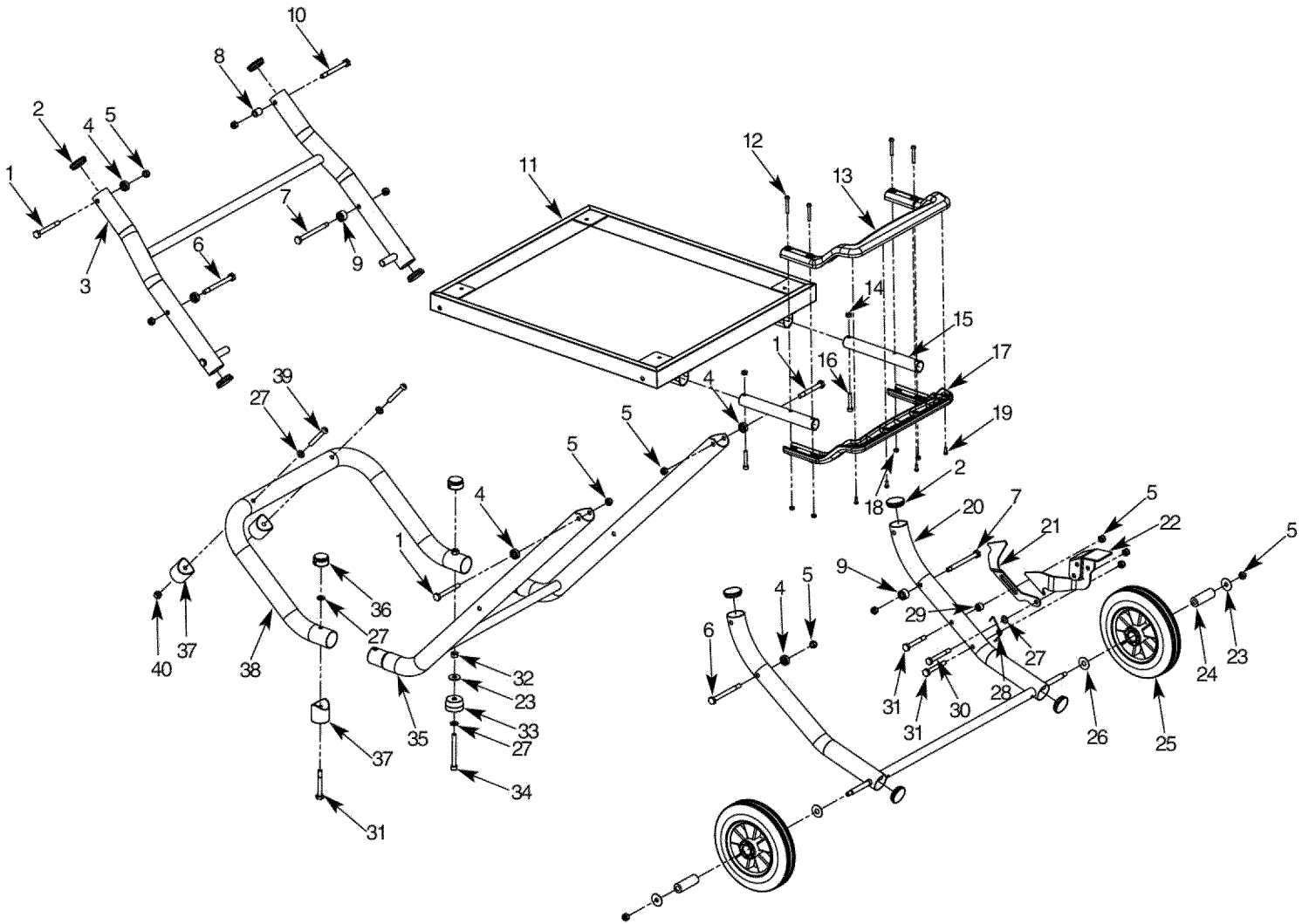

## REPLACEMENT PARTS LIST FOR STAND

KEY			
NO.	PART NO.	DESCRIPTION	QTY.
1	142580.155	Hexagon Bolt M8×70	3
2	142580.156	End Cap	8
3	142580.157	Stand Support (C)	1
4	142580.158	Spacer (A)	5
5	142580.159	Lock Nut M8	13
6	142580.160	Hexagon Bolt M8×90	2
7	142580.161	Hexagon Bolt M8×95	2
8	142580.162	Rolling Sleeve	1
9	142580.163	Spacer (C)	2
10	142580.164	Hexagon Bolt M8×80	1
11	142580.165	Stand Frame	1
12	142580.166	Cross Recess Pan Head Screw M5×35	4
13	142580.167	Upper Handle	1
14	142580.168	Locknut M6	2
15	142580.169	Support Bar	2
16	142580.170	Hexagon Socket Cap Screws M6×35	2
17	142580.171	Lower Handle	1
18	142580.172	Nut M5	4
19	142580.173	Cross Trough Pan Head Self-drilling Screw ST4.2×12	4
20	142580.174	Stand Support (B)	1
21	142580.175	Paddle (A)	1
22	142580.176	Paddle (C)	1
23	142580.177	Big Flat Washer 8	3
24	142580.178	Bushing	2
25	142580.179	Wheel Assembly	2
26	142580.180	Big Flat Washer 10	2
27	142580.181	Flat Washer 8	5
28	142580.182	Button Spring	1
29	142580.183	Spacer Bush	1
30	142580.184	Hexagon Bolt M8×65	1
31	142580.185	Hexagon Bolt M8×60	3
32	142580.186	Hexagon Thin Nut M8	1
33	142580.187	Shock Pad (A)	1
34	142580.188	Hexagon Socket Cap Screw M8×75	1
35	142580.189	Stand Support(A)	1
36	142580.190	Knob	2
37	142580.191	Foot	3
38	142580.192	Stand Support (D)	1
39	142580.193	Hexagon Socket Button Head M8×60	2
40	142580.194	Nut M8	3

# Model 141.142580

## Figure 66 - Replacement Parts Illustration for Blade Guard

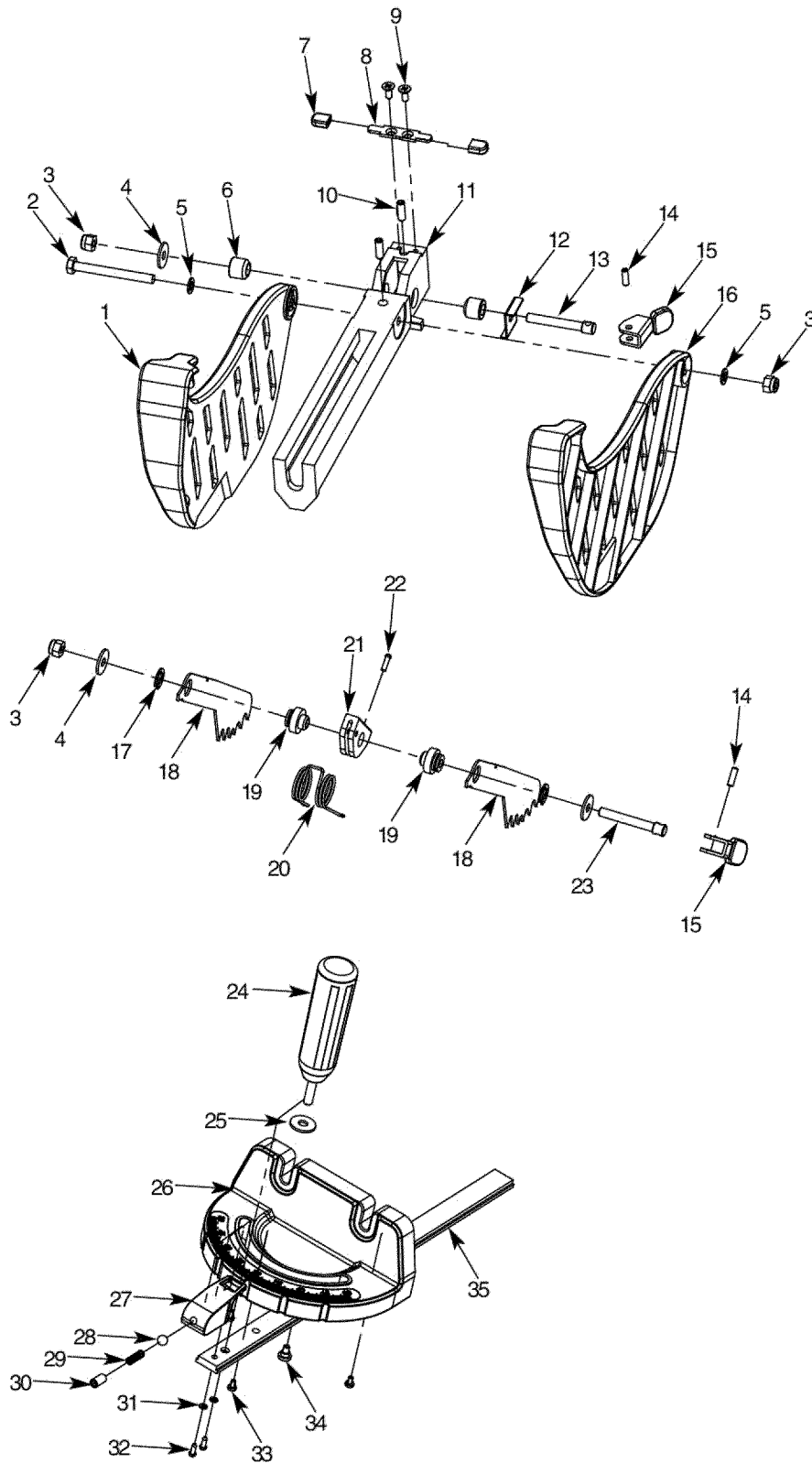

## REPLACEMENT PARTS LIST FOR BLADE GUARD

KEY			
NO.	PART NO.	DESCRIPTION	QTY.
1	142580.195	Left Blade Guard	1
2	142580.196	Hexagon Bolt M6x58	1
3	142580.197	Hexagon Lock Nut M6	3
4	142580.198	Washer (C)	3
5	142580.199	Flat Washer 6	2
6	142580.200	Clamping Sleeve(A)	2
7	142580.201	Sleeve	2
8	142580.202	Mounting Plate	1
9	142580.203	Cross Recessed Countersunk Head Screw M4x10	2
10	142580.204	Allen Flat End Set Screw M4x15	2
11	142580.205	Supporting Seat	1
12	142580.206	Gasket	2
13	142580.207	Connecting Shaft (A)	1
14	142580.208	Spring Pin 4x12	2
15	142580.209	Rotating Detent	2
16	142580.210	Right Blade Guard	1
17	142580.211	Split Washer	1
18	142580.212	Anti kickback Pawl	2
19	142580.213	Clamping Sleeve (B)	2
20	142580.214	Torsional Spring	1
21	142580.215	Holder	1
22	142580.216	Cross Recess Pan Head Screw M3x12	1
23	142580.217	Connecting Shaft (B)	1
24	142580.218	Locking Knob	1
25	142580.219	Big Flat Washer 6	1
26	142580.220	Miter Gauge	1
27	142580.221	Pointer	1
28	142580.222	Steel Ball	1
29	142580.223	Spring	1
30	142580.224	Allen Flat End Set Screw M6x12	1
31	142580.225	Flat Washer 3	2
32	142580.226	Cross Trough Pan Head Self-drilling Screw ST2.9x9	2
33	142580.227	Friction Pillar	3
34	142580.228	Positioning Bolt	1
35	142580.229	Guiding Bar	1

# **CRAFTSMAN<sup>®</sup>**

**Product questions or problems?**

# **1-888-331-4569**

## **Customer Care Hot Line**

**Get answers to questions, troubleshoot problems,  
order parts, or schedule repair service.**

Para respuestas a preguntas o problemas, y ordenar  
piezas o pedir servicio para la reparación de su equipo.

**To help us help you, register your product at [www.craftsman.com/registration](http://www.craftsman.com/registration)**

Para poderte ayudar mejor, registra tu producto en [www.craftsman.com/registration](http://www.craftsman.com/registration)

---

**Join the Craftsman Club today!**

## **CRAFTSMAN<sup>®</sup> CLUB**

**[www.craftsman.com/signup](http://www.craftsman.com/signup)**

**Receive exclusive member benefits including special pricing and offers,  
project sharing, expert advice, and SHOP YOUR WAY REWARDS!**

Como miembro exclusivo, recibe diversos beneficios como ofertas, precios especiales, proyectos nuevos, consejos de expertos y nuestro programa de puntos SHOP YOUR WAY REWARDS!