

# PRO-FORM<sup>®</sup>

## THINLINE ProDESK TREADMILL

Model No. 831.24942.0

Serial No. \_\_\_\_\_

Write the serial number in the space above for reference.

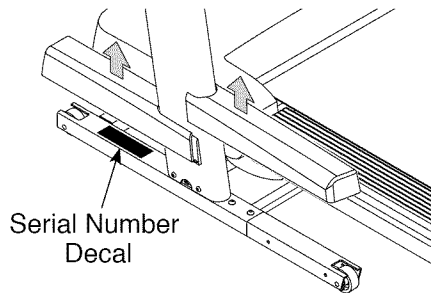

- Assembly
- Operation
- Maintenance
- Part List and Drawing

Sears, Roebuck and Co.  
Hoffman Estates, IL 60179

### CAUTION

Read all precautions and instructions in this manual before using this equipment. Keep this manual for future reference.

## TREADMILL EXERCISER

### User's Manual

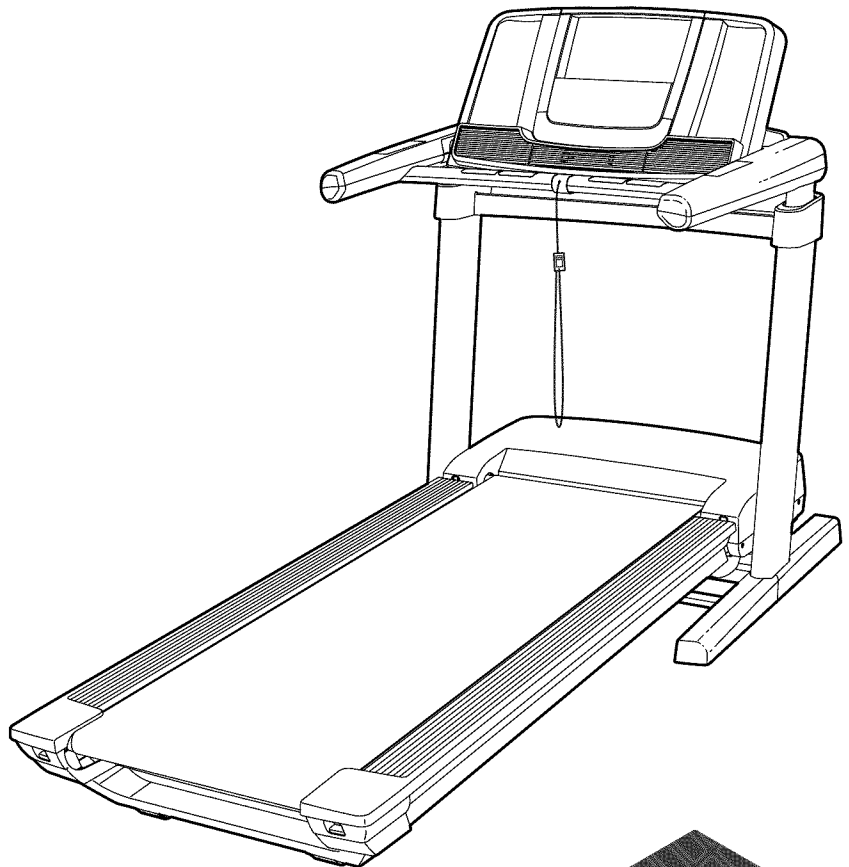

# TABLE OF CONTENTS

WARNING DECAL PLACEMENT ..... 2

IMPORTANT PRECAUTIONS ..... 3

BEFORE YOU BEGIN ..... 6

ASSEMBLY ..... 7

HOW TO USE THE TREADMILL ..... 11

HOW TO FOLD AND MOVE THE TREADMILL ..... 22

MAINTENANCE AND TROUBLESHOOTING ..... 23

EXERCISE GUIDELINES ..... 26

PART LIST ..... 29

EXPLODED DRAWING ..... 31

ORDERING REPLACEMENT PARTS ..... Back Cover

90-DAY FULL WARRANTY ..... Back Cover



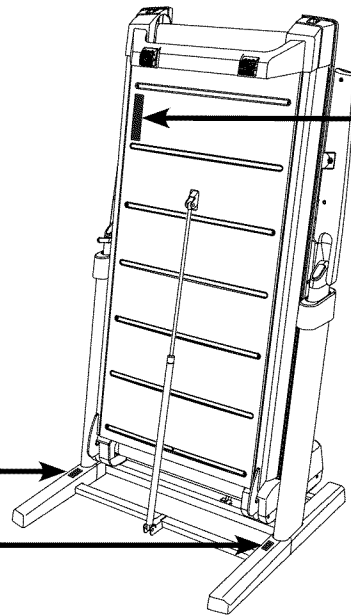

## WARNING DECAL PLACEMENT

This drawing shows the locations of the warning decals.  
**If a decal is missing or illegible, call 1-888-533-1333 and request a free replacement decal. Apply the decal in the location shown.** Note: The decals may not be shown at actual size.



**WARNING:**

Protect yourself and others from risk of serious injury. Read the user's manual and:

-  • Stand only on the side rails when starting or stopping treadmill.
- Change speed in small increments.
- Hold handrails to prevent falling, and always wear the safety clip while operating treadmill.
- Stop if you feel faint, dizzy, or short of breath.
- Fully engage storage latch before treadmill is moved or stored.
- Reduce incline to its lowest level before folding treadmill into storage position.
-  • Never allow children on or around treadmill.
- Remove key when not in use.
-  • Keep clothing, fingers, and hair away from moving belt.
- Never try to adjust or fix the belt while it is moving.
-  • Always wear athletic shoes while operating treadmill.

---

# IMPORTANT PRECAUTIONS

**⚠️ WARNING:** To reduce the risk of burns, fire, electric shock, or injury to persons, read all important precautions and instructions in this manual and all warnings on the treadmill before using the treadmill. Sears assumes no responsibility for personal injury or property damage sustained by or through the use of this product.

1. It is the responsibility of the owner to ensure that all users of this treadmill are adequately informed of all warnings and precautions.
2. Before beginning any exercise program, consult your physician. This is especially important for persons over age 35 or persons with pre-existing health problems.
3. Use the treadmill only as described in this manual.
4. The treadmill is intended for home use only. Do not use the treadmill in any commercial, rental, or institutional setting.
5. Keep the treadmill indoors, away from moisture and dust. Do not put the treadmill in a garage or covered patio, or near water.
6. Place the treadmill on a level surface, with at least 8 ft. (2.4 m) of clearance behind it and 2 ft. (0.6 m) on each side. Do not place the treadmill on any surface that blocks air openings. To protect the floor or carpet from damage, place a mat under the treadmill.
7. Do not operate the treadmill where aerosol products are used or where oxygen is being administered.
8. Keep children under age 12 and pets away from the treadmill at all times.
9. The treadmill should be used only by persons weighing 300 lbs. (136 kg) or less.
10. Never allow more than one person on the treadmill at a time.
11. Wear appropriate exercise clothes while using the treadmill. Do not wear loose clothes that could become caught in the treadmill. Athletic support clothes are recommended for both men and women. *Always wear athletic shoes. Never use the treadmill with bare feet, wearing only stockings, or in sandals.*
12. Plug the power cord into a surge suppressor (not included), and plug the surge suppressor into an appropriate outlet (see page 11). To avoid overloading the circuit, do not plug other electrical devices, except for low-power devices such as cell phone chargers, into the surge suppressor or into an outlet on the same circuit.
13. Use only a surge suppressor that meets all of the specifications described on page 11. To purchase a surge suppressor, see your local Sears store, call the telephone number on the back cover of this manual, or see your local electronics store.
14. Failure to use a properly functioning surge suppressor could result in damage to the control system of the treadmill. If the control system is damaged, the walking belt may slow, accelerate, or stop unexpectedly, which may result in a fall and serious injury.
15. Keep the power cord and the surge suppressor away from heated surfaces.
16. Never move the walking belt while the power is turned off. Do not operate the treadmill if the power cord or plug is damaged, or if the treadmill is not working properly. (See MAINTENANCE AND TROUBLESHOOTING on page 23 if the treadmill is not working properly.)
17. Read, understand, and test the emergency stop procedure before using the treadmill (see HOW TO TURN ON THE POWER on page 13). Always wear the clip while using the treadmill.
18. Never start the treadmill while you are standing on the walking belt.
19. Always stand on the foot rails when starting or stopping the walking belt.

20. Always hold the handrails or use the desk for stability while you are using the treadmill. Never pull upward on the handrails while you are using the treadmill.
21. Never raise the handrails to the storage position while the power cord is plugged in.
22. Keep fingers, hair, and clothing away from the moving walking belt.
23. The treadmill is capable of high speeds. Adjust the speed in small increments to avoid sudden jumps in speed.
24. The heart rate monitor is not a medical device. Various factors, including the user's movement, may affect the accuracy of heart rate readings. The heart rate monitor is intended only as an exercise aid in determining heart rate trends in general.
25. Never leave the treadmill unattended while it is running. Always remove the key, press the power switch into the off position (see the drawing on page 6 for the location of the power switch), and unplug the power cord when the treadmill is not in use.
26. Do not attempt to move the treadmill until it is properly assembled. (See ASSEMBLY on page 7 and HOW TO FOLD AND MOVE THE TREADMILL on page 22.) You must be able to safely lift 45 lbs. (20 kg) to move the treadmill.
27. When folding or moving the treadmill, make sure that the storage latch is holding the frame securely in the storage position.
28. Do not change the incline of the treadmill by placing objects under the treadmill.
29. Never insert any object into any opening on the treadmill.
30. Inspect and properly tighten all parts of the treadmill regularly.
31. **DANGER:** Always unplug the power cord immediately after use, before cleaning the treadmill, and before performing the maintenance and adjustment procedures described in this manual. Never remove the motor hood unless instructed to do so by an authorized service representative. Servicing other than the procedures in this manual should be performed by an authorized service representative only.
32. Over exercising may result in serious injury or death. If you feel faint, if you become short of breath, or if you experience pain while exercising, stop immediately and cool down.

**SAVE THESE INSTRUCTIONS**

# MAKE YOUR FITNESS GOALS A **REALITY**

**iFIT®**

Congratulations on the purchase of your new iFit® compatible fitness equipment. You're just one click away from making your fitness goals a reality.

**GO TO IFIT.COM TO GET STARTED**

## **DO MORE THAN JUST WORK OUT**

iFit® is the most powerful training tool available to help you accomplish all of your fitness goals. From weight loss and performance to personalized training programs, iFit® is the key to getting more out of everything you do. Some features require paid subscription.



### **LOSE WEIGHT**

Stay on track and motivated with progressive weight loss programs with our trainers, including Jillian Michaels.



### **COMPETE WITH OTHERS**

Push yourself to new limits with real-time virtual races.



### **PERSONALIZED EVENT TRAINING**

5k, 10k, half or full marathon training will help you prepare for your event.



### **GO MOBILE**

Track your workout anywhere you go with iFit® mobile apps.



### **MAP YOUR ROUTE**

With Google Maps™, your fitness equipment will simulate the earth's terrain while displaying Street View during your workout.



### **SHARE YOUR PROGRESS**

Inspire others, motivate yourself and share routes, workouts and more.

GO TO  
**IFIT.COM**

OR CALL  
**877-236-1009**

# BEFORE YOU BEGIN

Thank you for selecting the new PROFORM® THINLINE PRO DESK TREADMILL. The THINLINE PRO DESK TREADMILL provides an impressive selection of features designed to make your workouts at home more effective and enjoyable.

**For your benefit, read this manual carefully before you use the treadmill.** If you have questions after

reading this manual, please see the back cover of this manual. To help us assist you, note the product model number and serial number before contacting us. The model number and the location of the serial number decal are shown on the front cover of this manual.

Before reading further, please familiarize yourself with the parts that are labeled in the drawing below.

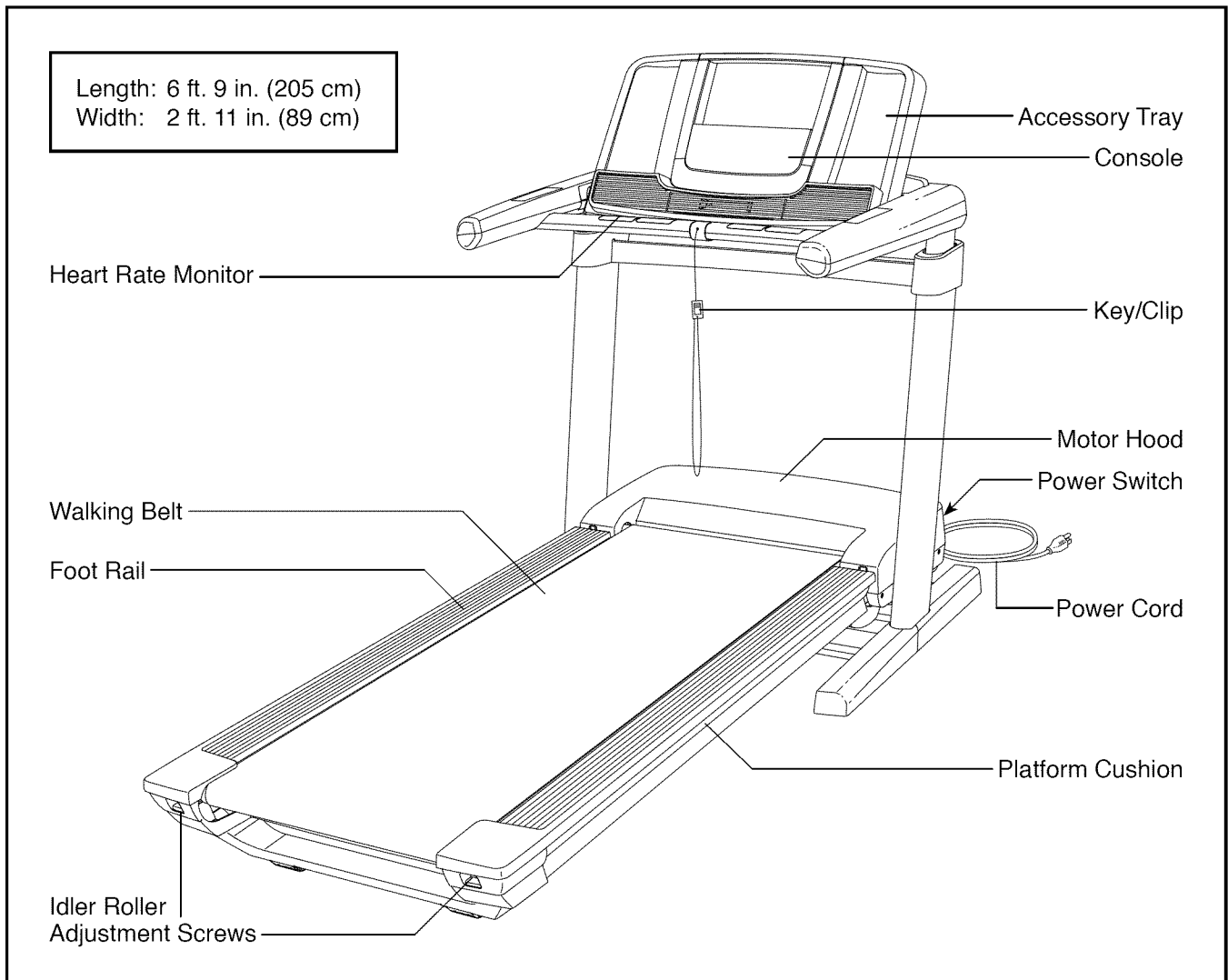

# ASSEMBLY

- Assembly requires two persons.
- Place all parts in a cleared area and remove the packing materials. Do not dispose of the packing materials until you finish all assembly steps.
- After shipping, there may be an oily substance on the exterior of the treadmill. This is normal. If there is an oily substance on the treadmill, wipe it off with a soft cloth and a mild, non-abrasive cleaner.
- Left parts are marked “L” or “Left” and right parts are marked “R” or “Right.”
- Assembly requires the following tools:  
the included hex key 
- To avoid damaging parts, do not use power tools.

1. **Go to [www.proformservice.com/registration](http://www.proformservice.com/registration) on your computer and register your product.**

- activates your warranty
- saves you time if you ever need to contact Customer Care
- allows us to notify you of upgrades and offers

Note: If you do not have Internet access, call 1-888-533-1333 and register your product.

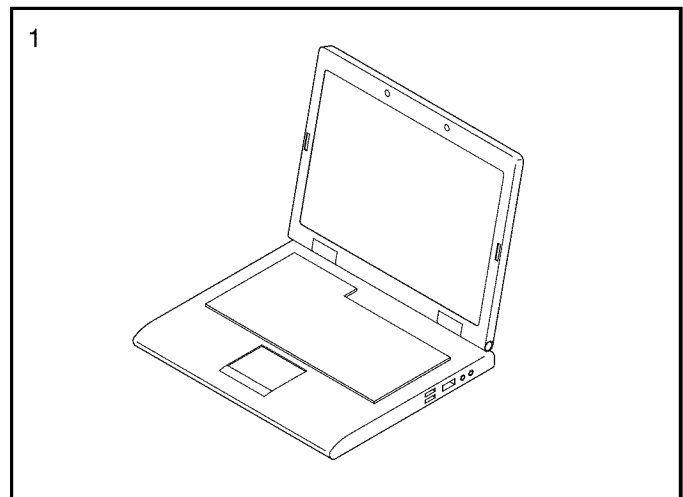

2. **Make sure that the power cord is unplugged.**

Remove the 5/16" x 1/2" Screws (1) and the 5/16" Star Washers (32) from the left and right Extension Legs (94). Save the Screws and the Star Washers.

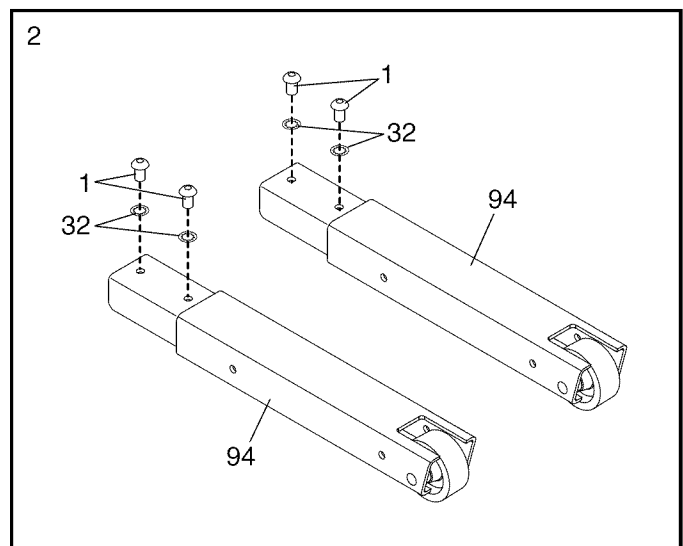

3. Attach the left Extension Leg (94) to the Base (100) with the two 5/16" x 1/2" Screws (1) and the two 5/16" Star Washers (32) that you removed in step 2.

**Repeat this step on the right side of the treadmill.**

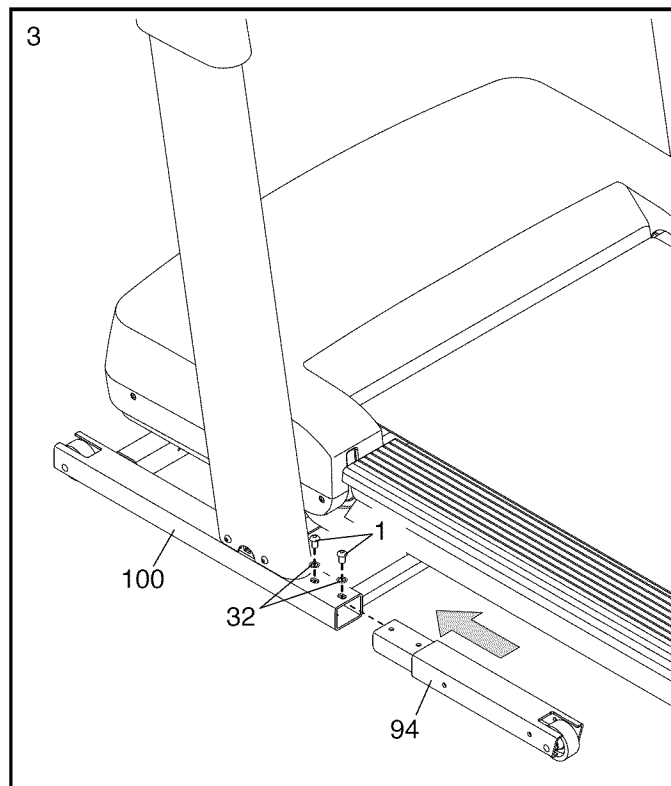

4. Identify the Left Base Cover (101) and the Left Extension Leg Cover (97).

Press the Left Base Cover (101) onto the Base (100). Then, press the Left Extension Leg Cover (97) onto the Base.

**Repeat this step on the right side of the treadmill.**

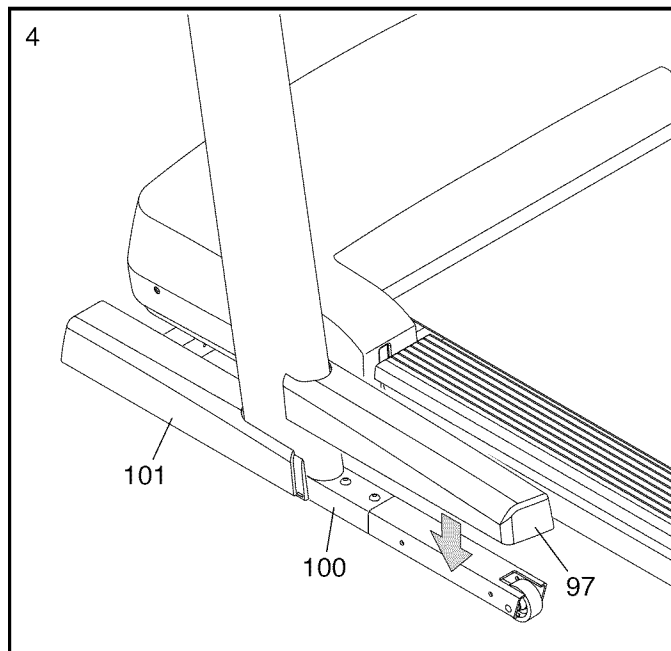



5. Locate the Latch (87) near the top of the left Upright (102). Press the Latch all of the way to the left and hold it. **IMPORTANT: Make sure that the Latch is pressed all of the way to the left.**

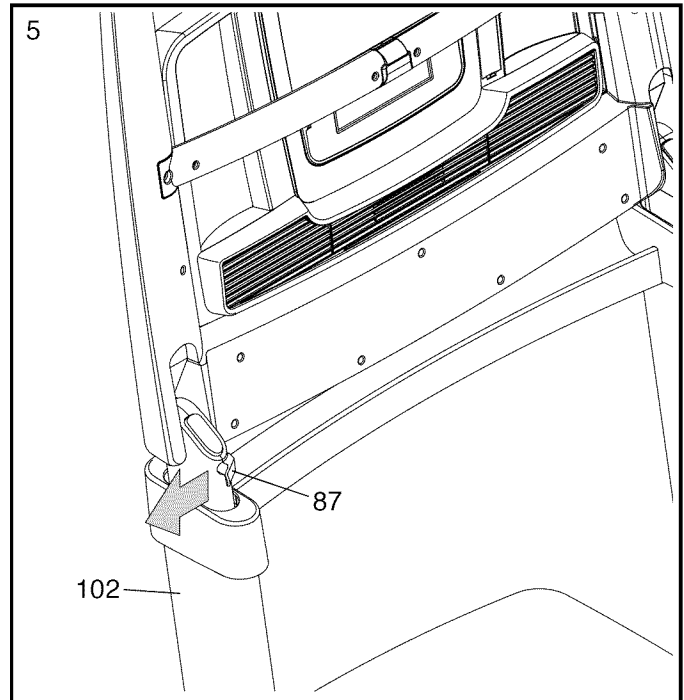

Carefully pivot the handrail assembly (A) down.

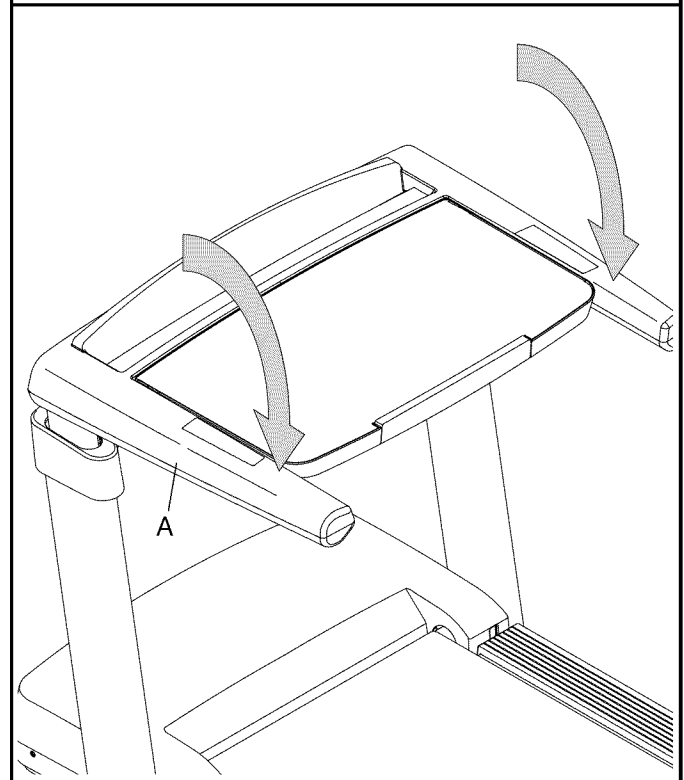

6. Carefully pivot the console assembly (B) up.

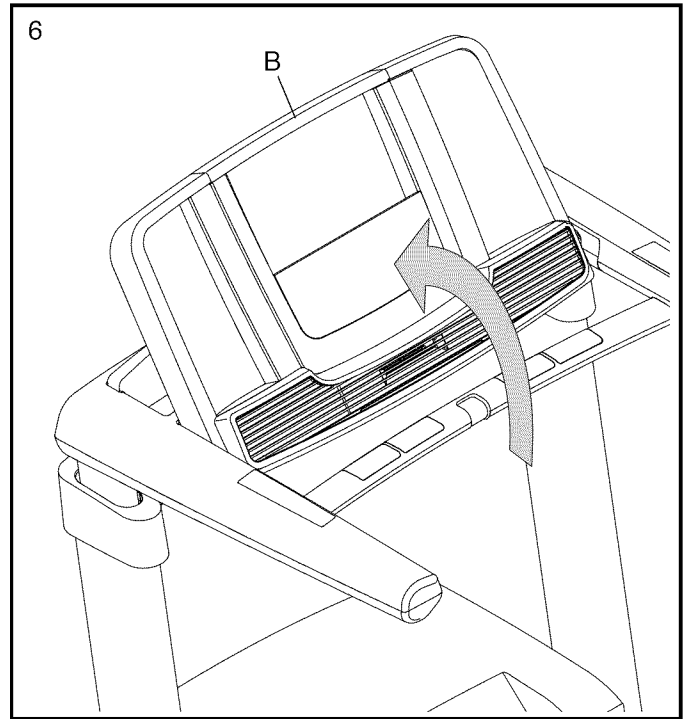

7. **Make sure that all parts are properly tightened before you use the treadmill.** If there are sheets of plastic on the treadmill decals, remove the plastic. To protect the floor or carpet, place a mat under the treadmill. To avoid damage to the console, keep the treadmill out of direct sunlight. Keep the included hex key in a secure place; the hex key is used to adjust the walking belt (see pages 24 and 25). Note: Extra parts may be included.

# HOW TO USE THE TREADMILL

## HOW TO CONNECT THE POWER CORD

### Use a Surge Suppressor

Your treadmill, like other electronic equipment, can be damaged by sudden voltage changes in your home's power. Voltage surges, spikes, and noise interference can result from weather conditions or from other appliances being turned on or off. **To decrease the risk of damaging the treadmill, always use a surge suppressor with the treadmill. To purchase a surge suppressor, see precaution 13 on page 3.**

Use only a surge suppressor that is UL 1449 listed as a transient voltage surge suppressor (TVSS). The surge suppressor must have a UL suppressed voltage rating of 400 volts or less and a minimum surge dissipation of 450 joules. The surge suppressor must also be electrically rated for 120 volts AC and 15 amps. There must be a monitoring light on the surge suppressor to indicate whether it is functioning properly. **Failure to use a properly functioning surge suppressor could result in damage to the control system of the treadmill and serious injury to users.**

### Plug in the Power Cord

**The treadmill must be grounded.** If it should malfunction or break down, grounding provides a path of least resistance for electric current to reduce the risk of electric shock. The treadmill power cord has a plug with a grounding pin (see drawing 1 on this page).

**⚠ DANGER:** Improper connection of the power cord increases the risk of electric shock. Do not modify the plug—if it will not fit an outlet, have a proper outlet installed by a qualified electrician. If you are unsure whether the treadmill is properly grounded, contact a qualified electrician.

Plug the power cord into a surge suppressor, and plug the surge suppressor into an appropriate outlet that is properly installed and grounded in accordance with all local codes and ordinances. **The outlet must be on a**

nominal 120-volt circuit capable of carrying 15 or more amps. To avoid overloading the circuit, do not plug other electrical devices, except for low-power devices such as cell phone chargers, into the surge suppressor or into an outlet on the same circuit. **IMPORTANT: The treadmill may not be compatible with AFCI-equipped outlets.**

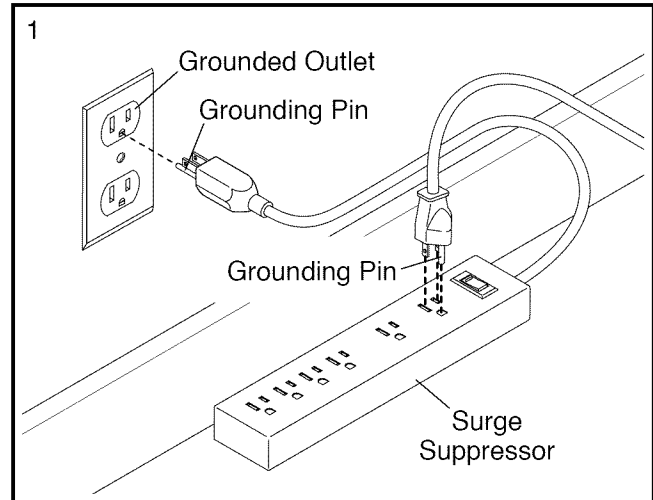

A temporary adapter may be used to connect the surge suppressor to a 2-pole receptacle if a properly grounded outlet is not available.

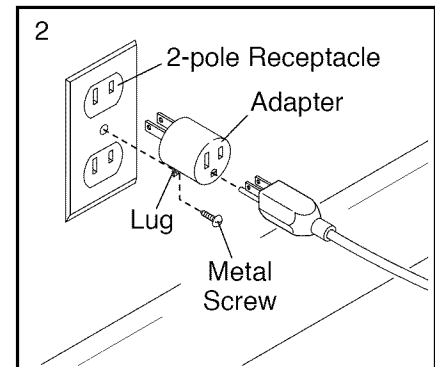

The lug or wire extending from the adapter must be connected with a metal screw to a permanent ground such as a properly grounded outlet box cover. **Some 2-pole receptacle outlet box covers are not grounded. Before using an adapter, contact a qualified electrician to determine whether the outlet box cover is grounded. The temporary adapter should be used only until a properly grounded outlet can be installed by a qualified electrician.**

## CONSOLE DIAGRAM

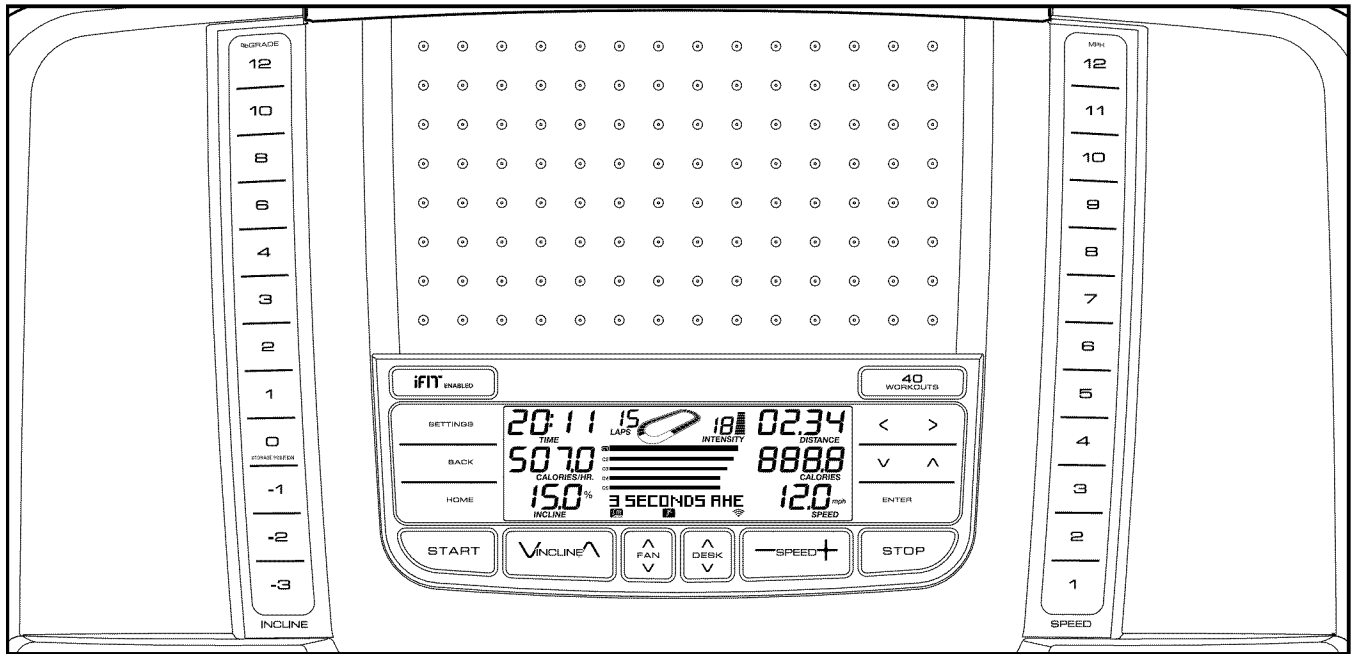

### FEATURES OF THE CONSOLE

The treadmill console offers an impressive array of features designed to make your workouts more effective and enjoyable. When you use the manual mode, you can change the speed and incline of the treadmill with the touch of a button. As you exercise, the console will display instant exercise feedback. You can even measure your heart rate using the handgrip heart rate monitor.

In addition, the console features a selection of on-board workouts. Each workout automatically controls the speed and incline of the treadmill as it guides you through an effective exercise session.

You can even use your tablet to control the speed and incline of the treadmill, or to access workouts. The console features an iFit mode when you connect your tablet. **See [www.iFit.com](http://www.iFit.com) for complete information.**

**To turn on the power**, see page 13. **To use the manual mode**, see page 13. **To use an onboard workout**, see page 15. **To use an iFit workout**, see page 16. **To use the settings mode**, see page 17. **To use your tablet with the console**, see page 20. **To adjust the uprights**, see page 21. **To use the desk**, see page 21.

Note: The console can display speed and distance in either miles or kilometers. To find which unit of measurement is selected, see THE SETTINGS MODE on page 17. For simplicity, all instructions in this section refer to miles.

**IMPORTANT: If there are sheets of plastic on the console, remove the plastic. To prevent damage to the walking platform, wear clean athletic shoes while using the treadmill. The first time you use the treadmill, observe the alignment of the walking belt, and center the walking belt if necessary (see page 25).**

## HOW TO TURN ON THE POWER

**IMPORTANT:** If the treadmill has been exposed to cold temperatures, allow it to warm to room temperature before you turn on the power. If you do not do this, you may damage the console displays or other electrical components.

**IMPORTANT:** Before you plug in the power cord, make sure that the handrails are lowered (see **HOW TO LOWER THE TREADMILL FOR USE** on page 22).

Plug in the power cord (see page 11). Next, locate the power switch on the treadmill frame near the power cord. Press the power switch into the reset position.

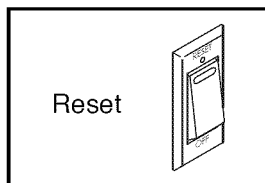

**IMPORTANT:** The console features a display demo mode, designed to be used if the treadmill is displayed in a store. If the displays light as soon as you plug in the power cord and press the power switch into the reset position, the demo mode is turned on. To turn off the demo mode, hold down the Stop button for a few seconds. If the displays remain lit, see **THE SETTINGS MODE** on page 17 to turn off the demo mode.

Next, stand on the foot rails of the treadmill. Find the clip attached to the key and slide the clip onto the waistband of your clothes. Then, insert the key into the console. After a moment, the displays will light.

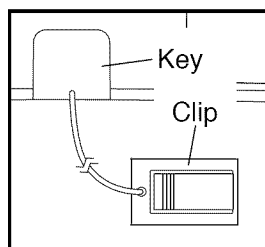

**IMPORTANT:** In an emergency, the key can be pulled from the console, causing the walking belt to slow to a stop. Test the clip by carefully taking a few steps backward; if the key is not pulled from the console, adjust the position of the clip.

**WARNING:** Never raise the handrails to the storage position while the power cord is plugged in.

## HOW TO USE THE MANUAL MODE

### 1. Insert the key into the console.

See **HOW TO TURN ON THE POWER** at the left.

### 2. Select the manual mode.

When the console is turned on, the manual mode will be selected. If a workout has been selected, press the Home button to select the manual mode.

### 3. Start the walking belt.

To start the walking belt, press the Start button, the Speed increase button, or one of the numbered Speed buttons.

If you press the Start button or the Speed increase button, the walking belt will begin to move at 1 mph. As you exercise, change the speed of the walking belt as desired by pressing the Speed increase and decrease buttons. Each time you press one of the buttons, the speed setting will change by 0.1 mph; if you hold down the button, the speed setting will change in increments of 0.5 mph. Note: After you press the buttons, it may take a moment for the walking belt to reach the selected speed setting.

If you press one of the numbered Speed buttons, the walking belt will gradually change speed until it reaches the selected speed setting. To select a speed setting that includes a decimal—such as 3.5 mph—press two numbered buttons in succession. For example, to select a speed setting of 3.5 mph, press the 3 button and then immediately press the 5 button. Note: This will not function if the console is set to metric units.

To stop the walking belt, press the Stop button. The time will begin to flash in the display. To restart the walking belt, press the Start button or the Speed increase button.

#### 4. Change the incline of the treadmill as desired.

To change the incline of the treadmill, press the Incline increase or decrease button or one of the numbered Incline buttons. Each time you press one of the buttons, the treadmill will gradually adjust to the selected incline setting.

#### 5. Follow your progress with the displays.

As you walk or run on the treadmill, the display can show the following workout information:

- The elapsed time
- The distance that you have walked or run
- The workout intensity level
- The approximate number of calories you have burned
- The approximate number of calories you are burning per hour
- The incline level of the treadmill
- The speed of the walking belt
- Your heart rate (see step 6)
- The matrix

The matrix offers several display options. Press the increase and decrease buttons next to the Enter button until the desired option is shown.

The Speed option will show a profile of the speed settings of the workout. A new segment will appear at the end of each minute.

The Incline option will show a profile of the incline settings of the workout. A new segment will appear at the end of each minute.

The Calorie option will show the approximate amount of calories you have burned. The height of each segment represents the amount of calories burned during that segment.

As you exercise, the workout intensity level bar will indicate the approximate intensity level of your exercise.



The display will also show a track that represents 1/4 mile (400 m). As you exercise, the rectangles around the track will show your progress. The number of laps you complete will be displayed next to the track.

Press the Home button to return to the main menu. If necessary, press the Home button again.

The wireless symbol in the bottom right corner of the display will show whether the console is connected to your wireless network. If it is flashing, the console is not connected. If it remains solid, the console is connected.



To reset the displays, press the Stop button, remove the key, and then reinsert the key.

#### 6. Measure your heart rate if desired.

Before using the heart rate monitor, remove the sheets of plastic from the metal contacts, if necessary. In addition, make sure that your hands are clean.

To measure your heart rate, **stand on the foot rails** and hold the metal contacts on the handrails for approximately ten seconds—**avoid moving your hands.**

When your pulse is detected, first a heart symbol in the calorie display will appear; next, one or two dashes will appear; and then your heart rate will be shown. **For the most accurate heart rate reading, continue to hold the contacts for about 15 seconds.**

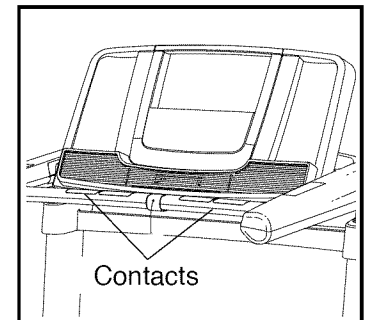

**7. Turn on the fan if desired.**

The fan features multiple speed settings. Press the fan decrease button repeatedly to select a fan speed or to turn off the fan. Press the fan increase button to select a fan speed or to turn on the fan.

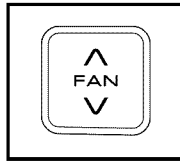

**8. When you are finished exercising, remove the key from the console.**

Step onto the foot rails, press the Stop button, and **adjust the incline of the treadmill to zero. The incline must be at zero or you may damage the treadmill when you fold it to the storage position.** Next, remove the key from the console and put it in a secure place.

When you are finished using the treadmill, press the power switch into the off position and unplug the power cord. **IMPORTANT: If you do not do this, the treadmill's electrical components may wear prematurely.**

**HOW TO USE AN ONBOARD WORKOUT**

**1. Insert the key into the console.**

See HOW TO TURN ON THE POWER on page 13.

**2. Select an onboard workout.**

To select an onboard workout, press the Workouts button repeatedly until the desired workout appears in the display.

When you select an onboard workout, the display will show the duration, the distance, the name, the approximate number of calories you will burn during the workout, the maximum incline setting, and the maximum speed setting of the workout. In addition, a profile of the incline settings of the workout will appear in the matrix.

**3. Start the workout.**

Press the Start button or the Speed increase button to start the workout. A moment after you press the button, the treadmill will automatically adjust to the first speed and incline settings of the workout. Hold the handrails and begin walking.

Each workout is divided into segments. One speed setting and one incline setting are programmed for each segment. Note: The same speed setting and/or incline setting may be programmed for consecutive segments.

During the workout, the profiles on the speed and incline tabs will show your progress.

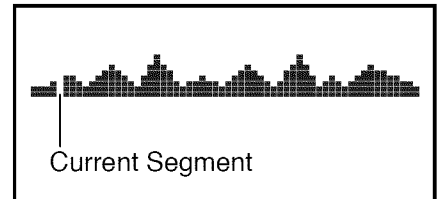

The flashing segment of the profile represents part of the current segment of the workout. The height of the flashing segment indicates the approximate speed or incline setting for the current segment. If a different speed and/or incline setting is programmed for the next segment, the treadmill will automatically adjust to the new speed and/or incline setting.

The workout will continue in this way until the last segment of the profile flashes in the display and the last segment ends. The walking belt will then slow to a stop.

**Note: The calorie goal is an estimate of the number of calories that you will burn during the workout. The actual number of calories that you burn will depend on various factors such as your weight. In addition, if you manually change the speed or incline of the treadmill during the workout, the number of calories you burn will be affected.**

If the speed or incline setting is too high or too low at any time during the workout, you can manually override the setting by pressing the Speed or Incline buttons; **however, when the next segment of the workout begins, the treadmill will automatically adjust to the speed and incline settings for the next segment.**

To stop the workout at any time, press the Stop button. The time will begin to flash in the display. To resume the workout, press the Start button or the Speed increase button. The walking belt will begin to move at 1 mph. When the next segment of the workout begins, the treadmill will automatically adjust to the speed and incline settings for the next segment.

**4. Follow your progress with the displays.**

See step 5 on page 14.

**5. Measure your heart rate if desired.**

See step 6 on page 14.

**6. Turn on the fan if desired.**

See step 7 on page 15.

**7. When you are finished exercising, remove the key from the console.**

See step 8 on page 15.

## HOW TO USE AN IFIT WORKOUT

Note: To use an iFit workout, you must have access to a wireless network (see pages 17 to 20) and you must connect your tablet to the console. An iFit account is also required.

**1. Insert the key into the console.**

See HOW TO TURN ON THE POWER on page 13.

**2. Connect your tablet to the console.**

See page 20 and connect your tablet to the console.

**3. Access iFit workouts.**

Follow the instructions on the iFit app to access iFit workouts. When you select an iFit workout, the display will show the name, duration, maximum speed setting, and distance of the workout. The display will also show the approximate number of calories you will burn during the workout and a profile of the speed settings of the workout.

**4. Start the workout.**

See step 3 on page 15.

To stop the workout at any time, press the Stop button. The time will begin to flash in the display. To resume the workout, press the Start button or the Speed increase button. The walking belt will begin to move at the speed setting for the first segment of the workout. When the next segment of the workout begins, the treadmill will automatically adjust to the speed and incline settings for the next segment.

**5. Follow your progress with the displays.**

See step 5 on page 14.

The My Trail tab will show a map of the trail you are walking or running or it will show a track and the number of laps you complete.



During a competition workout, the Competition tab will show your progress in the race. As you race, the top line in the matrix will show how much of the race you have completed. The other lines will show your top four competitors. The end of the matrix represents the end of the race.

**6. Measure your heart rate if desired.**

See step 6 on page 14.

**7. Turn on the fan if desired.**

See step 7 on page 15.

**8. When you are finished exercising, remove the key from the console.**

See step 8 on page 15.

**For more information about the iFit feature, go to [www.iFit.com](http://www.iFit.com).**

## THE SETTINGS MODE

The console features a settings mode that allows you to view usage information, to personalize console settings, and to set up and manage a wireless network connection.

**1. Select the settings mode.**

To select the settings mode, press the Settings button. The settings mode will then appear in the display.

The time display will show the total number of hours that the treadmill has been used.

The distance display will show the total number of miles (or kilometers) that the walking belt has moved.

**2. Navigate the settings mode menu.**

The matrix will display a menu of the settings mode options.

Press the increase and decrease buttons next to the Enter button to highlight the desired option.

**Units**—The selected unit of measurement will appear in the matrix. To change the unit of measurement, press the Enter button. To view distance in miles, select ENGLISH. To view distance in kilometers, select METRIC.

**Contrast**—The contrast level of the display will appear in the matrix. Press the Incline increase and decrease buttons to adjust the contrast level.

**Firmware Update**—**For the best results, regularly check for firmware updates.**

Note: The matrix will display NOT CONNECTED if the console is not connected to a wireless network.

Press the Enter button to check for firmware updates using your wireless network. If an update is available, the update will begin automatically. The lower part of the matrix will display instructions for the highlighted option. **Make sure to follow the instructions displayed in the lower part of the matrix.**

**IMPORTANT: To avoid damaging the treadmill, do not turn off the power while the firmware is being updated. The update may take several minutes.**

Note: Occasionally, a firmware update may cause your console to function slightly differently. These updates are always designed to improve your exercise experience.

### 3. Select the optional screens.

**Demo**—The console features a display demo mode, designed to be used if the treadmill is displayed in a store. While the demo mode is turned on, the console will function normally when you plug in the power cord, press the power switch into the reset position, and insert the key into the console. However, when you remove the key, the displays will remain lit, although the buttons will not function. If the demo mode is turned on, the word ON will appear in the matrix. To turn on or turn off the demo mode, press the Enter button.

**Default Settings**—To restore the console to its factory default settings, press the Enter button. Note: The console will erase any information that you have saved in its memory.

The **WiFi–Normal** option will allow you to set up a wireless network connection using the console. See step 4 for instructions.

The **WiFi–Advanced** option will allow you to set up a wireless network connection using your computer, smart phone, tablet, or other Wi-Fi device. See step 6 for instructions.

**iFit User Setup**—A numerical code and a web address will appear in the matrix. Go to the web address on your internet-compatible device.

**Clear WiFi**—To erase the console’s wireless network settings and have it forget the currently selected wireless network, follow the instructions in the matrix.

### 4. Use WiFi–Normal to set up a wireless connection.

This option will allow you to set up a wireless network connection using the console.

Note: You will need to know your network name (SSID). If your network has a password, you will also need to know the password.

To set up a wireless network connection using the console, first press the Enter button.

A list of networks will appear in the matrix. Press the up and down buttons to highlight the desired network. Then, press the Enter button. When the cursor passes the first and last networks in the list, the console will rescan for access points. Note: Do not select IFIT\_SETUP.

Note: The time display will show the number of the currently-selected access point. The distance display will show the total number of access points detected.

If the network has a password, enter the password.

A keyboard will appear in the matrix. Press the up, down, left, and right buttons to highlight the desired letter or number. Then, press the Enter button to select the letter, number, or symbol. When you have finished entering the password, press the Done button.

A numerical code and a web address will appear in the matrix. Go to the web address on your internet-compatible device.

Log in to your iFit account on the web page. Then, enter the numerical code into the indicated field. Follow any other instructions on the web page.

**When the console is connected to a wireless network**, the wireless symbol in the display will stop flashing and become solid. The wireless symbol will show the strength of your wireless signal; four arcs indicate full signal strength.

**If you cannot complete any part of this process, or if you have any questions, go to <http://support.ifit.com> for assistance.**

#### **5. Use WiFi–WPS to set up a wireless connection.**

This option will allow you to set up a wireless network connection using your WPS router.

To set up a wireless network connection using your WPS router, first press the Enter button and follow the instructions in the matrix.

A numerical code and a web address will appear in the matrix. Go to the web address on your internet-compatible device.

Log in to your iFit account on the web page. Then, enter the numerical code into the indicated field. Follow any other instructions on the web page.

**When the console is connected to a wireless network**, the wireless symbol in the display will stop flashing and become solid. The wireless symbol will show the strength of your wireless signal; four arcs indicate full signal strength.

**If you cannot complete any part of this process, or if you have any questions, go to <http://support.ifit.com> for assistance.**

#### **6. Use WiFi–Advanced to set up a wireless connection.**

This option will allow you to set up a wireless network connection using your computer, smart phone, tablet, or other Wi-Fi device.

On your computer, smart phone, tablet, or other Wi-Fi device, open the list of available networks to which your device can connect. One of the options will be IFIT\_SETUP; select this network. If this network does not appear, make sure that your Wi-Fi device is within range of the console, and then close and re-open your list of networks. Also, see CLEAR WIFI on page 18 and clear any previous wireless network settings on the console.

**Note: The network IFIT\_SETUP will not appear if the console has already been configured to connect to a wireless network. Also, Android™ devices may not be able to detect IFIT\_SETUP.**

The console will display an IP address, such as 192.168.0.1:8080. Open a web browser on your computer, smart phone, tablet, or other Wi-Fi device. Next, type in the IP address on the console into the URL bar in your browser. Example: <http://192.168.0.1:8080>.

Your browser will load a web page. If the web page does not appear, double-check the IP address and the previous instructions of this step. Follow the instructions on the web page to connect the treadmill to your wireless network.

Note: A warning may appear stating that the server cannot be identified. If this happens, make sure that you have entered the IP address correctly.

**If you cannot complete any part of this process, or if you have any questions, go to [support.ifit.com](http://support.ifit.com) for assistance.**

## 7. Exit the settings mode.

To exit the settings mode, press the Settings button.

## HOW TO USE YOUR TABLET WITH THE CONSOLE

Note: To connect your tablet to the console, you must have access to a wireless network (see pages 17 to 20). An iFit account and an iFit app are also required. **Go to [www.iFit.com](http://www.iFit.com) to sign up for an account and to download the app.**

### 1. Set up a wireless connection on the console.

See pages 17 to 20. Note: The console and your tablet must be connected to the same wireless network.

### 2. Access the iFit app on your tablet and sign into your iFit account.

### 3. Enter an IP address.

Select the Settings mode (see step 1 on page 17). Next, enter the console's IP address on your tablet. Touch Connect on the tablet. Follow the prompts on your tablet to complete this step.

### 4. Control the treadmill using your tablet.

Once you have established a wireless connection between your tablet and the console, you can control the treadmill using the options on your tablet. From your tablet, you can access workouts and adjust the speed and incline. **Note: The console must be in manual mode for you to run a workout with your tablet. The buttons on the console will continue to function in addition to the tablet controls. If you pause a workout on your tablet, the workout can only be resumed using the controls on your tablet.**

### 5. Log out and exit.

When you are finished using your tablet, touch the link in the upper right corner of the tablet to log out.

**For more information about the iFit app, go to [www.iFit.com](http://www.iFit.com).**

## HOW TO USE THE TABLET HOLDER

If you plan to use your tablet when the console is in the upright position, secure your tablet to the console before you begin using the treadmill. Pull the tablet holder upward, place your tablet on the console, and then release the tablet holder. The tablet holder will then hold your tablet in place.

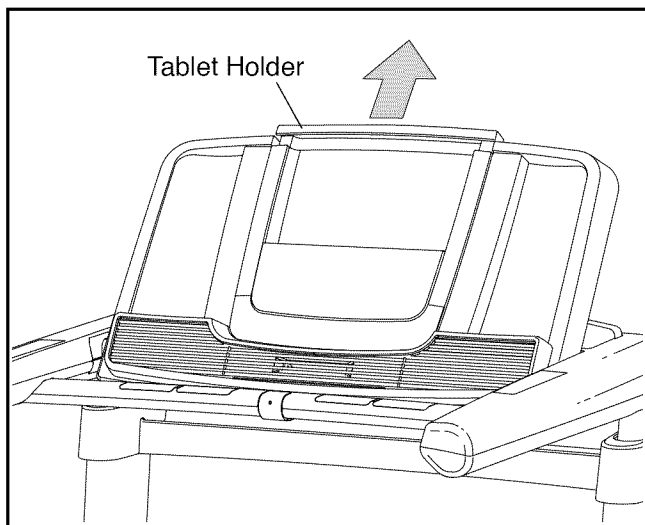

## HOW TO ADJUST THE UPRIGHTS

The uprights feature multiple height settings. To adjust the height of the uprights, press the Desk increase and decrease buttons on the console or on the handle controls until the uprights have reached the desired height.

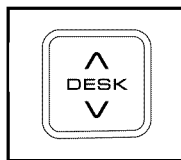

## HOW TO POSITION THE CONSOLE

The console can be used in either the upright position (see drawing 1) or the desk position (see drawing 2). To raise the console to the upright position, place one hand on a handrail. Then, press upward on the front of the console with your other hand. To lower the console to the desk position, first **make sure that your tablet is not on the console**. Then, press downward on the back of the console. Note: When the console is in the desk position, use the controls on the handrail to operate the treadmill.

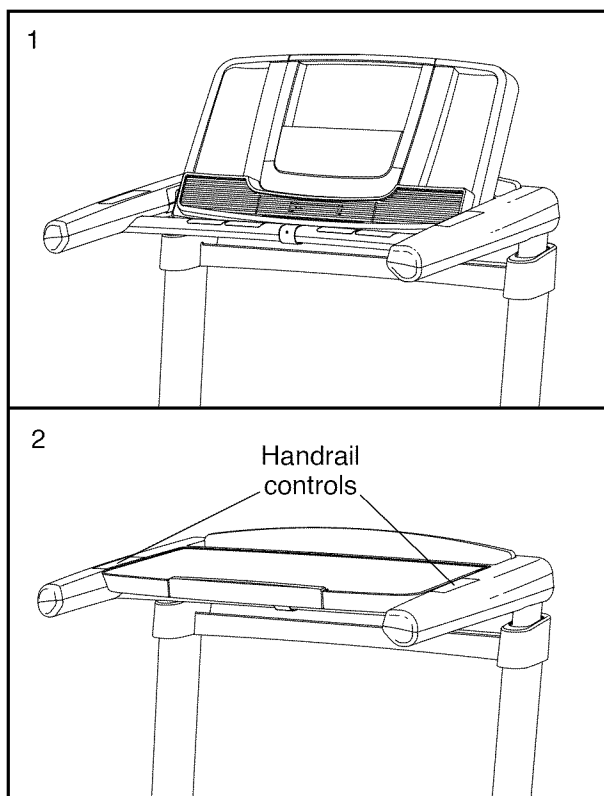

# HOW TO FOLD AND MOVE THE TREADMILL

## HOW TO FOLD THE TREADMILL

To avoid damaging the treadmill, adjust the incline to zero before you fold the treadmill. **CAUTION:** Remove the key and unplug the power cord. You must be able to safely lift 45 lbs. (20 kg) to raise, lower, or move the treadmill.

1. Raise the handrails to the vertical position.

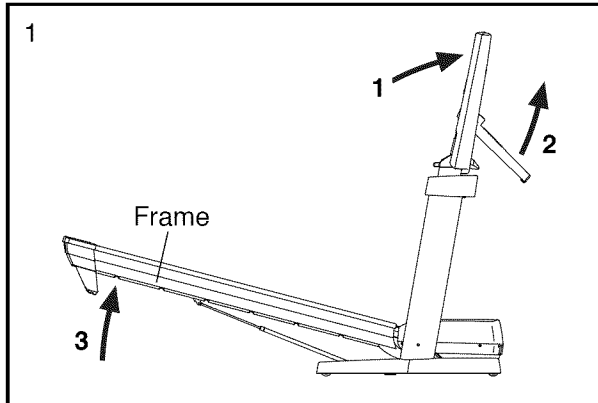

2. Raise the console to the vertical position.
3. Hold the metal frame firmly in the location shown by the arrow above. **CAUTION: Do not hold the frame by the plastic foot rails. Bend your legs and keep your back straight.**
4. Raise the frame until the latch locks onto the catch. **CAUTION: Make sure that the latch locks onto the catch.**

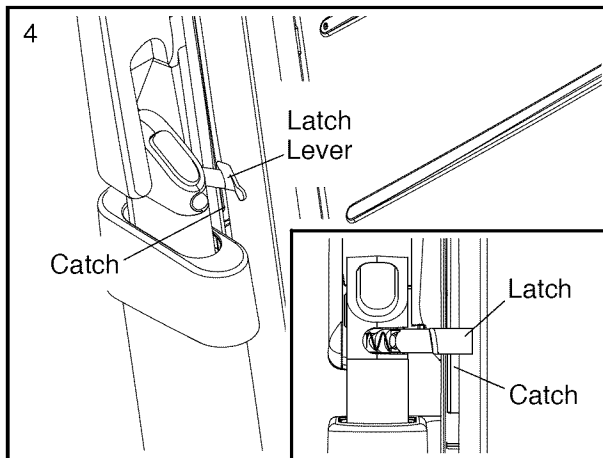

To protect the floor or carpet, place a mat under the treadmill. Keep the treadmill out of direct sunlight. Do not leave the treadmill in the storage position in temperatures above 85° F (30° C).

## HOW TO MOVE THE TREADMILL

Before moving the treadmill, fold it as described at the left. **CAUTION: Make sure that the catch is held securely by the latch. Moving the treadmill may require two people.**

1. Hold the frame with both hands and carefully push the treadmill to the desired location. **CAUTION: Do not pull on the frame, and do not move the treadmill over an uneven surface.**

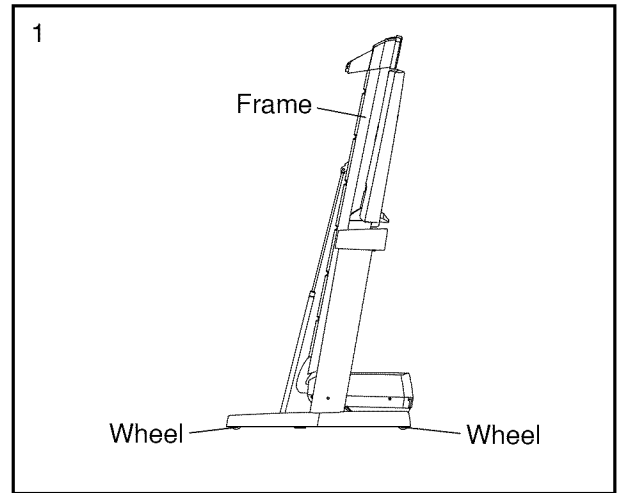

## HOW TO LOWER THE TREADMILL FOR USE

1. **See drawing 4.** Hold the upper end of the treadmill with your right hand. Next, press the latch lever all of the way to the left and hold it. **If necessary, push the frame forward slightly.** Pivot the frame downward a few inches, and release the latch lever.
2. **See drawing 1 at the left.** Hold the metal frame firmly with both hands, and lower it to the floor. **CAUTION: Bend your legs and keep your back straight.**
3. **See drawing 4 at the left.** Press the latch all of the way to the left, and lower the handrails. Then, raise the console to the upright position.

# MAINTENANCE AND TROUBLESHOOTING

## MAINTENANCE

Regularly clean the treadmill and keep the walking belt clean and dry. First, **press the power switch into the off position and unplug the power cord.** Wipe exterior parts of the treadmill with a damp cloth and a small amount of mild soap. **IMPORTANT: Do not spray liquids directly onto the treadmill. To avoid damage to the console, keep liquids away from the console.** Then, thoroughly dry the treadmill with a soft towel.

## TROUBLESHOOTING

**Most treadmill problems can be solved by following the simple steps below. Find the symptom that applies, and follow the steps listed. If further assistance is needed, see the back cover of this manual.**

### SYMPTOM: The power does not turn on

- Make sure that the power cord is plugged into a surge suppressor and that the surge suppressor is plugged into a properly grounded outlet (see page 11). Use only a surge suppressor that meets all of the specifications described on page 11. **IMPORTANT: The treadmill may not be compatible with AFCI-equipped outlets.**
- After the power cord has been plugged in, make sure that the key is inserted into the console.
- Check the power switch located on the treadmill frame near the power cord. If the switch protrudes as shown, the switch has tripped. To reset the power switch, wait for five minutes and then press the switch back in.

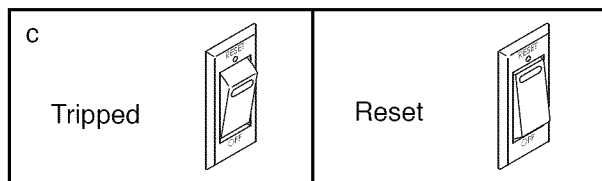

### SYMPTOM: The power turns off during use

- Check the power switch (see the drawing above). If the switch has tripped, wait for five minutes and then press the switch back in.

- Make sure that the power cord is plugged in. If the power cord is plugged in, unplug it, wait for five minutes, and then plug it back in.
- Remove the key from the console, and then reinsert it.
- If the treadmill still will not run, please see the back cover of this manual.

### SYMPTOM: The console displays remain lit when you remove the key from the console

- The console features a display demo mode, designed to be used if the treadmill is displayed in a store. If the displays remain lit when you remove the key, the demo mode is turned on. To turn off the demo mode, hold down the Stop button for a few seconds. If the displays are still lit, see THE SETTINGS MODE on page 17 to turn off the demo mode.

### SYMPTOM: The displays of the console do not function properly

- Adjust the incline of the treadmill to its highest setting. Then, remove the key from the console and **UNPLUG THE POWER CORD.** With the help of another person, carefully tip the treadmill on its side as shown. Next, remove the two #8 x 3/4" Screws (8). Return the treadmill to its upright position.

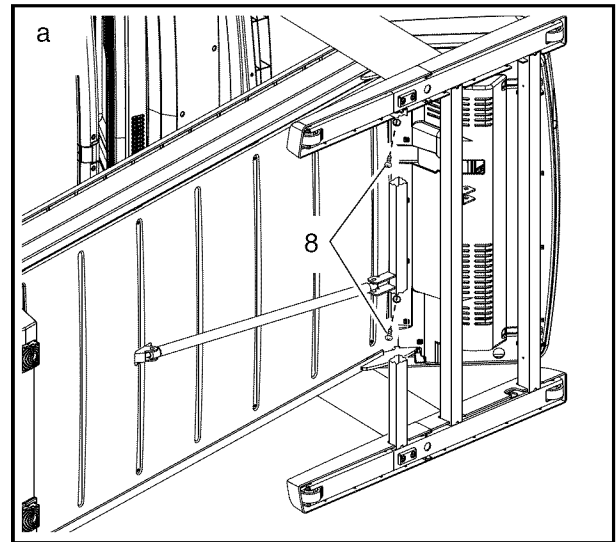

- b. Remove the seven #8 x 3/4" Screws (8). Carefully slide off the Motor Hood (57).

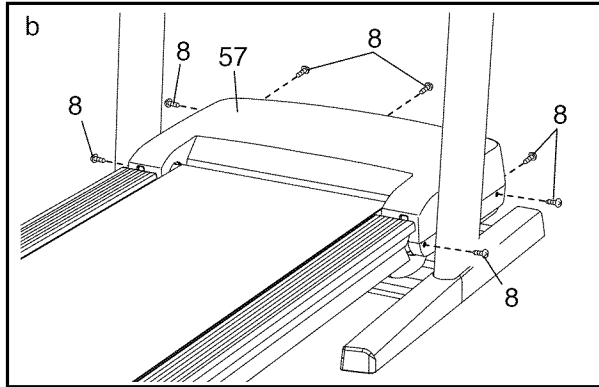

Locate the Reed Switch (68) and the Magnet (119) on the left side of the Pulley (49). Turn the Pulley until the Magnet is aligned with the Reed Switch.

**Make sure that the gap between the Magnet and the Reed Switch is about 1/8 in. (3 mm).** If necessary, loosen the #8 x 3/4" Truss Head Screw (13), move the Reed Switch slightly, and then retighten the Screw. Reattach the Motor Hood (not shown) with the #8 x 3/4" Screws (not shown) and run the treadmill for a few minutes to check for a correct speed reading.

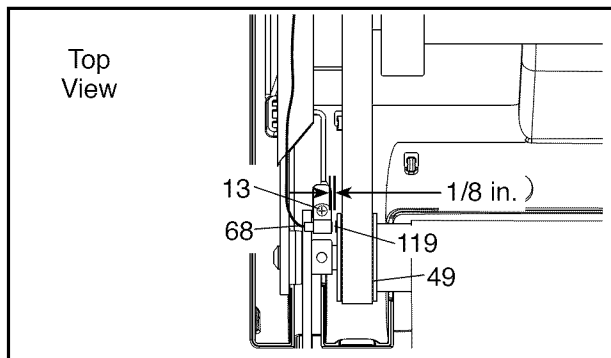

**SYMPTOM: The incline of the treadmill does not change correctly**

- a. Hold down the Stop button and the Speed increase button, insert the key into the console, and then release the Stop button and the Speed increase button. Next, press the Stop button and then press the Incline increase or decrease button. The treadmill will automatically rise to the maximum incline level and then return to the minimum level. This will recalibrate the incline system. If the incline system does not begin calibrating, press the Stop button again, and then press the Incline increase or decrease button again. When the incline system is calibrated, remove the key from the console.

**SYMPTOM: The walking belt slows when walked on**

- a. Use only a surge suppressor that meets all of the specifications described on page 11.
- b. If the walking belt is overtightened, treadmill performance may decrease and the walking belt may become damaged. Remove the key and **UNPLUG THE POWER CORD**. Using the hex key, turn both idler roller screws counterclockwise, 1/4 of a turn. When the walking belt is properly tightened, you should be able to lift each edge of the walking belt 2 to 3 in. (5 to 7 cm) off the walking platform. Be careful to keep the walking belt centered. Then, plug in the power cord, insert the key, and run the treadmill for a few minutes. Repeat until the walking belt is properly tightened.

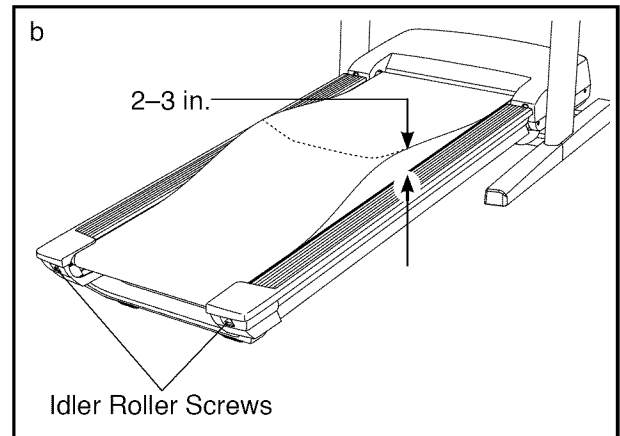



- c. Your treadmill features a walking belt coated with high-performance lubricant. **IMPORTANT: Never apply silicone spray or other substances to the walking belt or the walking platform unless instructed to do so by an authorized service representative. Such substances may deteriorate the walking belt and cause excessive wear.** If you suspect that the walking belt needs more lubricant, see the front cover of this manual.
- d. If the walking belt still slows when walked on, see the back cover of this manual.

**SYMPTOM: The walking belt is off-center or slips when walked on**

- a. **If the walking belt is off-center**, first remove the key and **UNPLUG THE POWER CORD**. **If the walking belt has shifted to the left**, use the hex key to turn the left idler roller screw clockwise 1/2 of a turn; **if the walking belt has shifted to the right**, turn the left idler roller screw counterclockwise 1/2 of a turn. Be careful not to overtighten the walking belt. Then, plug in the power cord, insert the key, and run the treadmill for a few minutes. Repeat until the walking belt is centered.

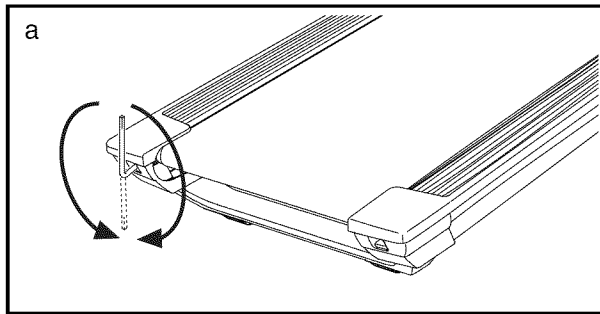

- b. **If the walking belt slips when walked on**, first remove the key and **UNPLUG THE POWER CORD**. Using the hex key, turn both idler roller screws clockwise, 1/4 of a turn. When the walking belt is correctly tightened, you should be able to lift each edge of the walking belt 2 to 3 in. (5 to 7 cm) off the walking platform. Be careful to keep the walking belt centered. Then, plug in the power cord, insert the key, and carefully walk on the treadmill for a few minutes. Repeat until the walking belt is properly tightened.

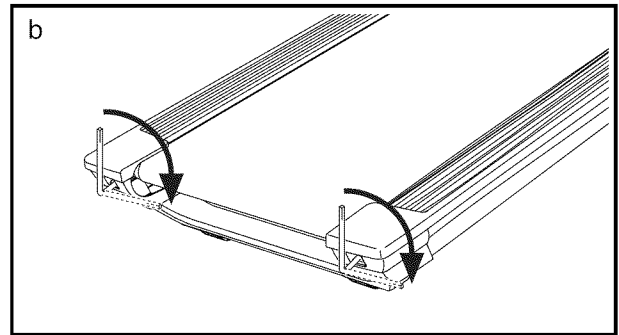

# EXERCISE GUIDELINES

**⚠ WARNING:** Before beginning this or any exercise program, consult your physician. This is especially important for persons over age 35 or persons with pre-existing health problems.

The heart rate monitor is not a medical device. Various factors may affect the accuracy of heart rate readings. The heart rate monitor is intended only as an exercise aid in determining heart rate trends in general.

These guidelines will help you to plan your exercise program. For detailed exercise information, obtain a reputable book or consult your physician. Remember, proper nutrition and adequate rest are essential for successful results.

## EXERCISE INTENSITY

Whether your goal is to burn fat or to strengthen your cardiovascular system, exercising at the proper intensity is the key to achieving results. You can use your heart rate as a guide to find the proper intensity level. The chart below shows recommended heart rates for fat burning and aerobic exercise.

165	155	145	140	130	125	115	♥♥
145	138	130	125	118	110	103	♥
125	120	115	110	105	95	90	♥
<hr/>							
20	30	40	50	60	70	80	

To find the proper intensity level, find your age at the bottom of the chart (ages are rounded off to the nearest ten years). The three numbers listed above your age define your “training zone.” The lowest number is the heart rate for fat burning, the middle number is the heart rate for maximum fat burning, and the highest number is the heart rate for aerobic exercise.

**Burning Fat**—To burn fat effectively, you must exercise at a low intensity level for a sustained period of time. During the first few minutes of exercise, your body uses carbohydrate calories for energy. Only after the first few minutes of exercise does your body begin to use stored fat calories for energy. If your goal is to burn fat, adjust the intensity of your exercise until your heart rate is near the lowest number in your training zone. For maximum fat burning, exercise with your heart rate near the middle number in your training zone.

**Aerobic Exercise**—If your goal is to strengthen your cardiovascular system, you must perform aerobic exercise, which is activity that requires large amounts of oxygen for prolonged periods of time. For aerobic exercise, adjust the intensity of your exercise until your heart rate is near the highest number in your training zone.

## WORKOUT GUIDELINES

**Warming Up**—Start with 5 to 10 minutes of stretching and light exercise. A warm-up increases your body temperature, heart rate, and circulation in preparation for exercise.

**Training Zone Exercise**—Exercise for 20 to 30 minutes with your heart rate in your training zone. (During the first few weeks of your exercise program, do not keep your heart rate in your training zone for longer than 20 minutes.) Breathe regularly and deeply as you exercise; never hold your breath.

**Cooling Down**—Finish with 5 to 10 minutes of stretching. Stretching increases the flexibility of your muscles and helps to prevent post-exercise problems.

## EXERCISE FREQUENCY

To maintain or improve your condition, complete three workouts each week, with at least one day of rest between workouts. After a few months of regular exercise, you may complete up to five workouts each week, if desired. Remember, the key to success is to make exercise a regular and enjoyable part of your everyday life.

## SUGGESTED STRETCHES

The correct form for several basic stretches is shown at the right. Move slowly as you stretch—never bounce.

### 1. Toe Touch Stretch

Stand with your knees bent slightly and slowly bend forward from your hips. Allow your back and shoulders to relax as you reach down toward your toes as far as possible. Hold for 15 counts, then relax. Repeat 3 times. Stretches: Hamstrings, back of knees and back.

### 2. Hamstring Stretch

Sit with one leg extended. Bring the sole of the opposite foot toward you and rest it against the inner thigh of your extended leg. Reach toward your toes as far as possible. Hold for 15 counts, then relax. Repeat 3 times for each leg. Stretches: Hamstrings, lower back and groin.

### 3. Calf/Achilles Stretch

With one leg in front of the other, reach forward and place your hands against a wall. Keep your back leg straight and your back foot flat on the floor. Bend your front leg, lean forward and move your hips toward the wall. Hold for 15 counts, then relax. Repeat 3 times for each leg. To cause further stretching of the achilles tendons, bend your back leg as well. Stretches: Calves, achilles tendons and ankles.

### 4. Quadriceps Stretch

With one hand against a wall for balance, reach back and grasp one foot with your other hand. Bring your heel as close to your buttocks as possible. Hold for 15 counts, then relax. Repeat 3 times for each leg. Stretches: Quadriceps and hip muscles.

### 5. Inner Thigh Stretch

Sit with the soles of your feet together and your knees outward. Pull your feet toward your groin area as far as possible. Hold for 15 counts, then relax. Repeat 3 times. Stretches: Quadriceps and hip muscles.

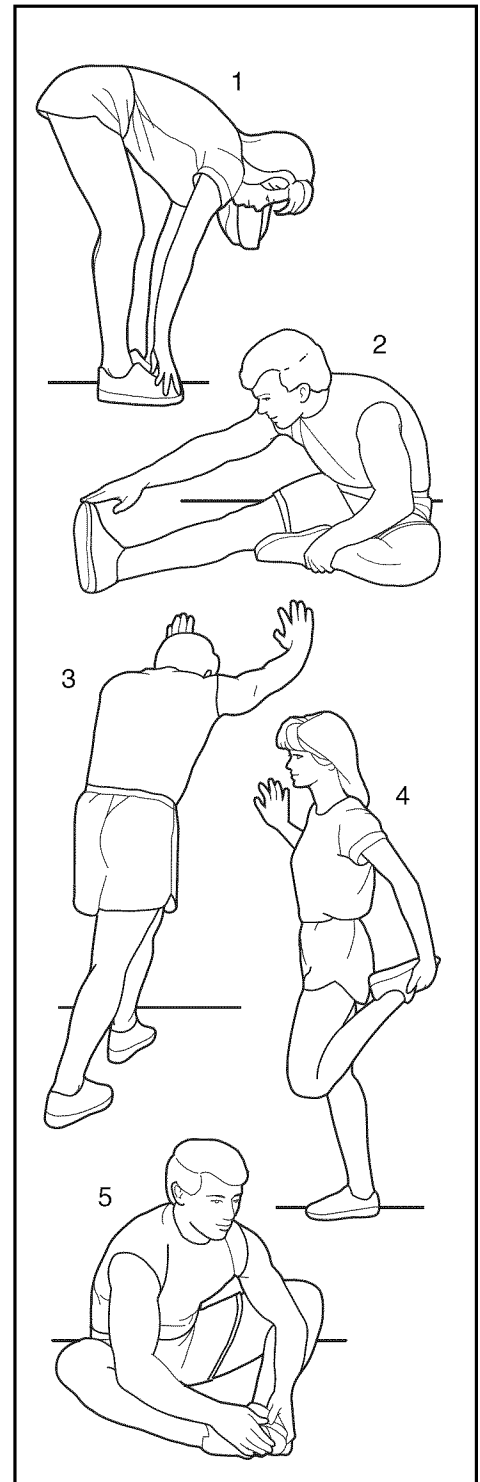

---

# NOTES

# PART LIST

Model No. 831.24942.0 R0814A

Key No.	Qty.	Description	Key No.	Qty.	Description
1	4	5/16" x 1/2" Screw	51	1	Right Footrail
2	4	3/8" x 2 3/8" Bolt	52	1	Frame
3	2	1/4" x 2 1/2" Screw	53	1	Right Frame Cover
4	2	3/8" x 3/4" Screw	54	1	Frame Cover
5	8	1/4" x 1/2" Screw	55	2	Rear Foot
6	2	1/4" x 1 1/2" Screw	56	1	Rear Cap
7	1	1/4" x 1 1/2" Bolt	57	1	Motor Hood
8	57	#8 x 3/4" Screw	58	1	Controller
9	16	#8 x 1/2" Screw	59	1	Electronics Bracket
10	10	#8 x 3/8" Screw	60	3	Wire Tie
11	10	#8 x 1 1/4" Screw	61	1	Incline Frame
12	2	#8 x 1/4" Screw	62	1	Idler Roller
13	5	#8 x 3/4" Truss Head Screw	63	1	Frame Guide Spacer
14	8	#8 x 5/8" Screw	64	1	Incline Motor
15	1	3/8" x 1 3/4" Bolt	65	2	Frame Spacer
16	1	3/8" x 1 1/2" Bolt	66	1	Drive Motor Belt
17	2	3/8" x 1" Bolt	67	1	Drive Motor
18	2	5/16" Drive Motor Bolt	68	1	Reed Switch
19	8	#8 Belt Guide Screw	69	1	Reed Switch Clip
20	4	5/16" x 1 3/4" Shoulder Bolt	70	1	Power Supply
21	9	#8 x 1/2" Machine Screw	71	1	Power Cord
22	2	5/16" x 2" Screw	72	1	Power Switch
23	8	#6 x 3/8" Screw	73	1	Belly
24	6	1/4" x 1" Flat Head Screw	74	1	Upright Motor Controller
25	10	#8 x 3/4" Tek Screw	75	1	Left Outside Pivot Cover
26	6	#8 x 3/4" Flat Head Screw	76	2	Center Cover
27	9	#8 x 1/2" Tek Screw	77	1	Left Inside Pivot Cover
28	1	1/4" Star Washer	78	1	Tray
29	2	#8 Star Washer	79	1	Right Inside Pivot Cover
30	2	3/8" Flat Washer	80	1	Right Outside Pivot Cover
31	4	5/16" Flat Washer	81	1	Upright Wire
32	6	5/16" Star Washer	82	1	Grommet
33	8	7/8" Star Washer	83	1	Grommet Plate
34	7	Hood Clip	84	2	Top Upright Guide
35	8	3/8" Nut	85	1	Latch Spacer
36	6	5/16" Nut	86	1	Latch Spring
37	4	7/8" Nut	87	1	Latch
38	2	1/4" Flat Washer	88	1	Latch Lever
39	22	7/8" Plastic Washer	89	1	Left Upright
40	2	Axle	90	1	Right Upright
41	1	Latch Bracket	91	2	Bottom Upright Guide
42	1	Warning Decal	92	2	Upright Motor
43	4	Platform Cushion	93	2	Isolation Block
44	1	Left Frame Cover	94	2	Extension Leg
45	1	Walking Platform	95	8	Wheel Spacer
46	1	Walking Belt	96	4	Wheel
47	2	Belt Guide	97	1	Left Extension Leg Cover
48	4	Rubber Cushion	98	1	Right Extension Leg Cover
49	1	Front Roller/Pulley	99	2	Base Pad
50	1	Left Footrail	100	1	Base

Key No.	Qty.	Description	Key No.	Qty.	Description
101	1	Left Base Cover	114	1	Console
102	1	Upright	115	5	Wire clamp
103	1	Right Base Cover	116	2	Pivot Clamp
104	1	Left Control Panel	117	1	Console Frame
105	1	Right Control Panel	118	1	Pulse Crossbar
106	1	Handrail	119	1	Magnet
107	1	Top Handrail Cover	120	1	1/4" x 1" Screw
108	1	Bottom Handrail Cover	121	2	#8 Flat Washer
109	1	Key/Clip	122	1	Frame Guide
110	1	Pulse Bar Cover	123	1	5/16" x 1 1/2" Bolt
111	2	Caution Decal	124	1	5/16" x 1 3/4" Bolt
112	8	Console Fastener	125	1	Gas Shock
113	1	Console Back	*	-	User's Manual

Note: Specifications are subject to change without notice. For information about ordering replacement parts, see the back cover of this manual. **If a part is missing, call 1-888-533-1333.** \*These parts are not illustrated.

# EXPLODED DRAWING A

Model No. 831.24942.0 R0814A

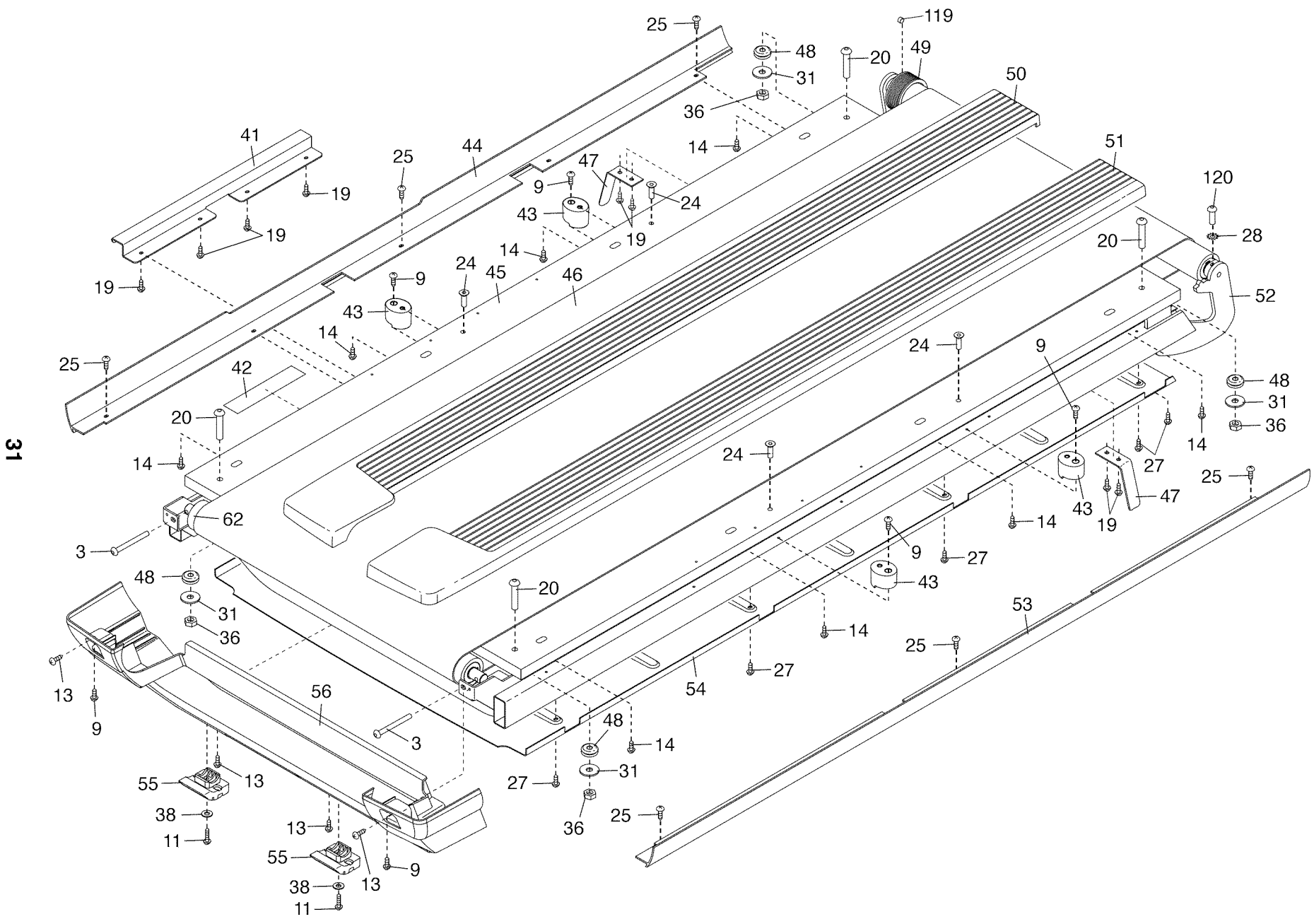

# EXPLODED DRAWING B

Model No. 831.24942.0 R0814A

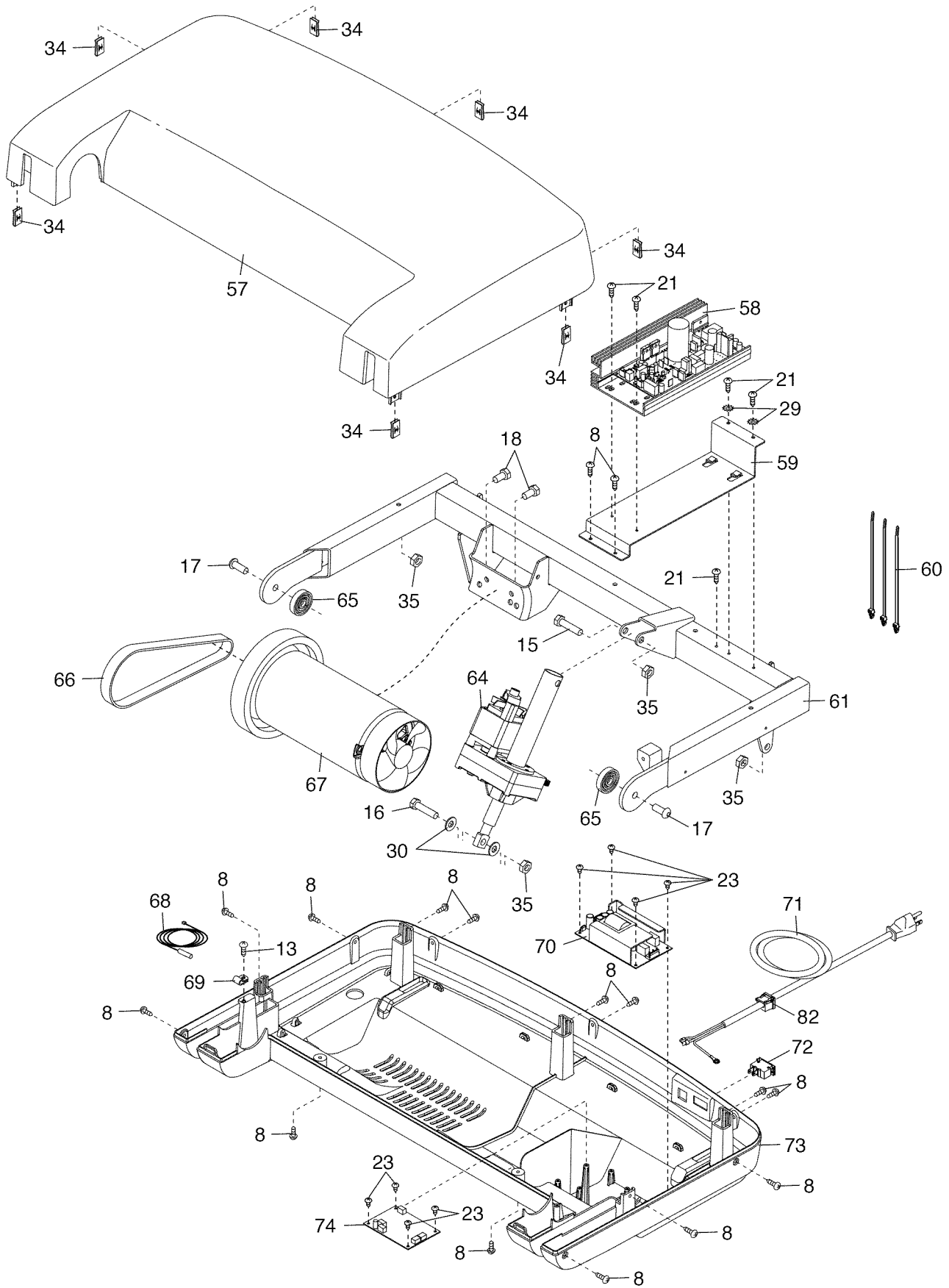



# EXPLODED DRAWING C

Model No. 831.24942.0 R0814A

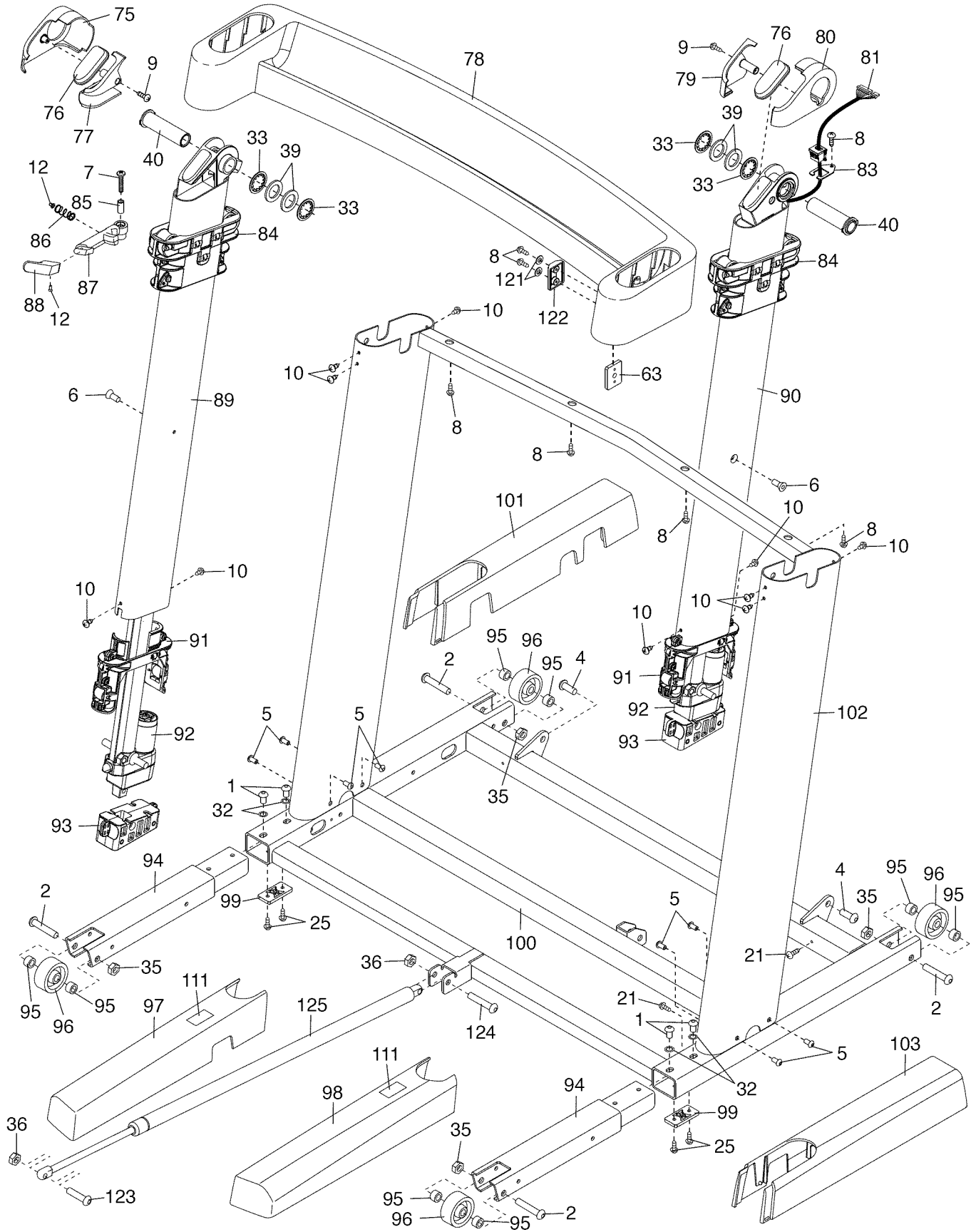

# EXPLODED DRAWING D

Model No. 831.24942.0 R0814A

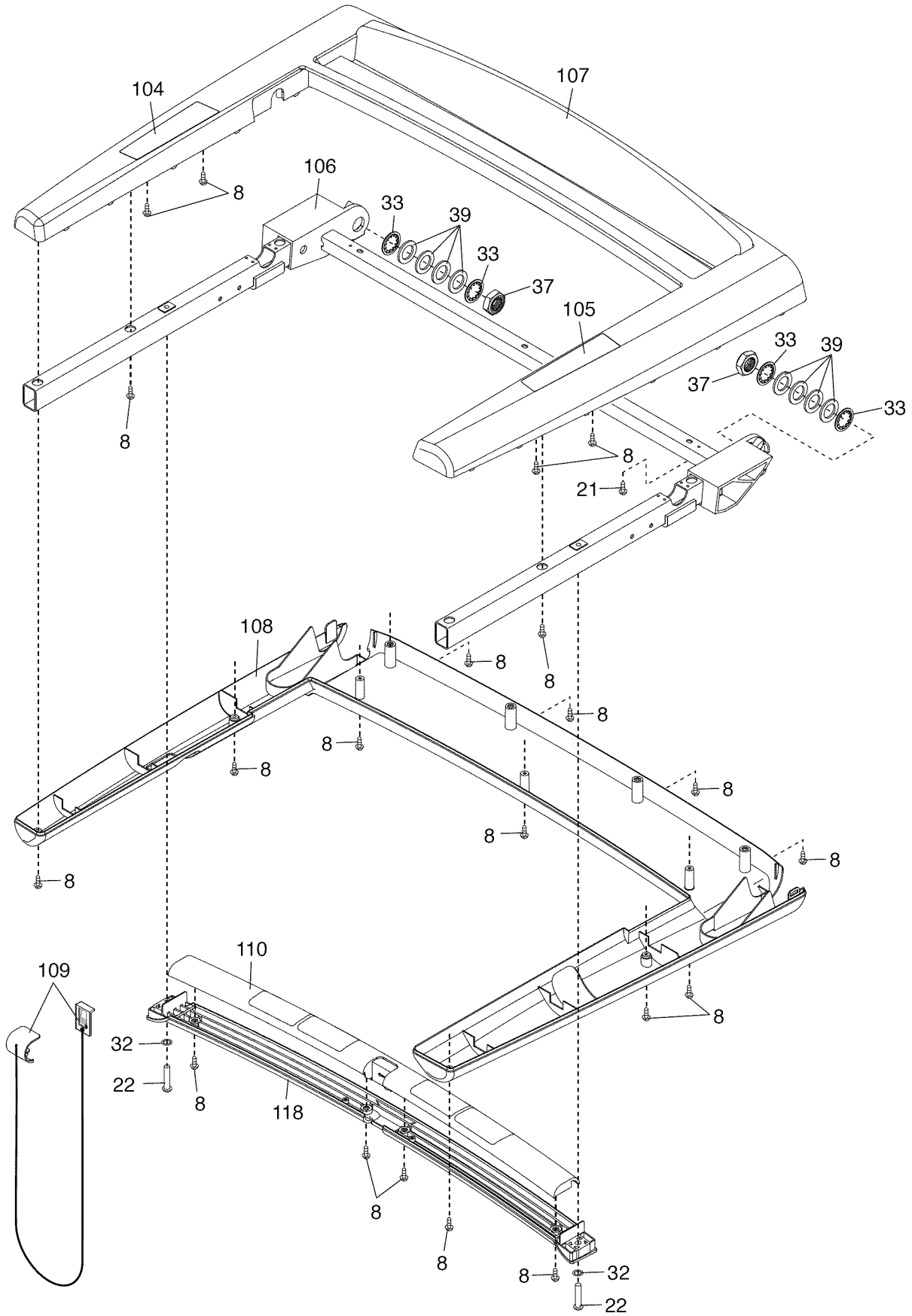

# EXPLODED DRAWING E

Model No. 831.24942.0 R0814A

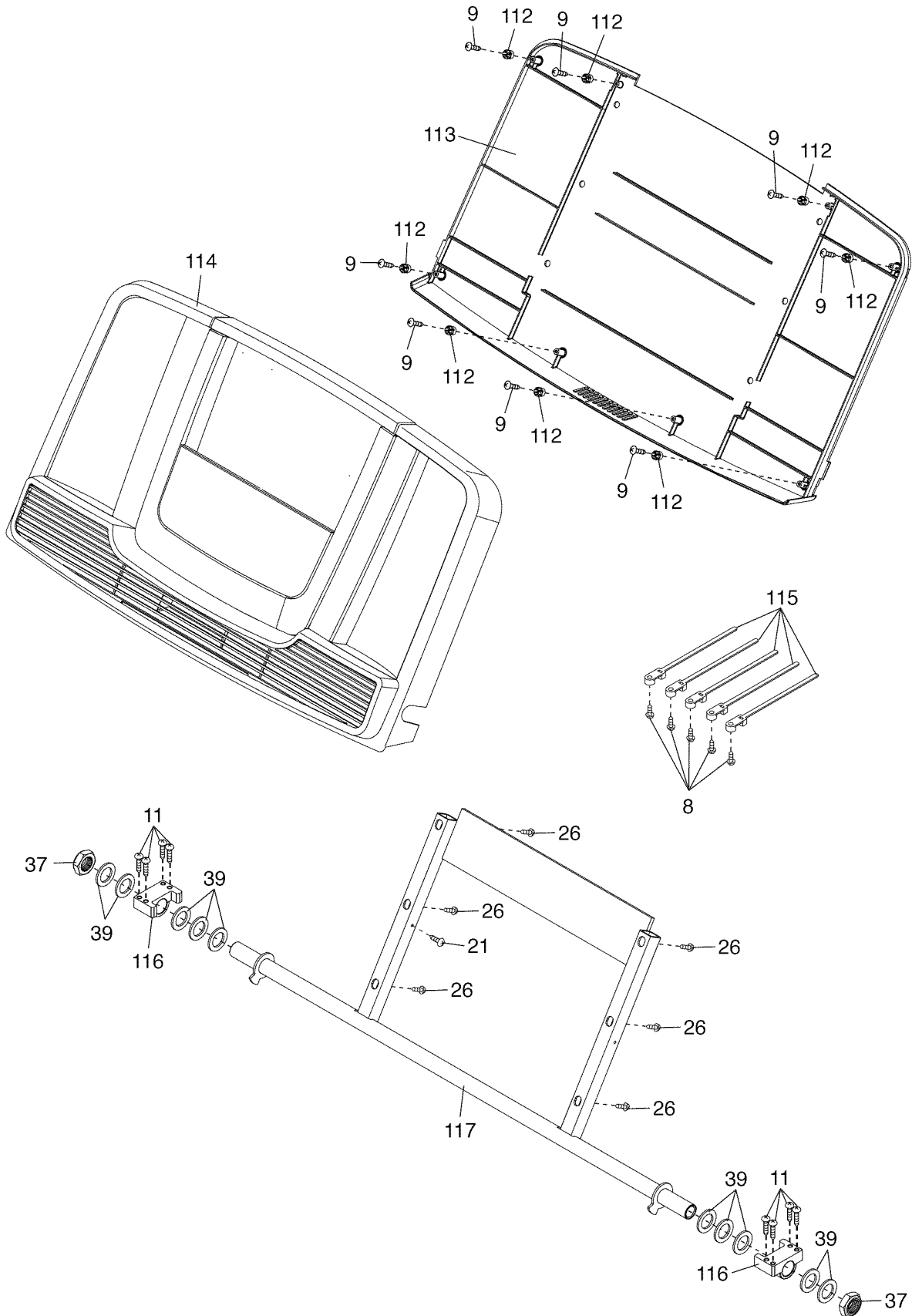

## Get it fixed, at your home or ours!

### Your Home

For repair—**in your home**—of **all** major brand appliances, lawn and garden equipment, or heating and cooling systems, **no matter who made it, no matter who sold it!**

For the replacement parts, accessories, and user's manuals that you need to do-it-yourself.

For Sears professional installation of home appliances and items like garage door openers and water heaters.

**1-800-4-MY-HOME® (1-800-469-4663)**

Call anytime, day or night (U.S.A. and Canada)

[www.sears.com](http://www.sears.com)

[www.sears.ca](http://www.sears.ca)

### Our Home

For repair of carry-in items like vacuums, lawn equipment, and electronics, call or go on-line for the location of your nearest **Sears Parts & Repair Center.**

**1-800-488-1222** Call anytime, day or night (U.S.A. only)

[www.sears.com](http://www.sears.com)

To purchase a protection agreement (U.S.A.) or maintenance agreement (Canada) on a product serviced by Sears:

**1-800-827-6655** (U.S.A.)

**1-800-361-6665** (Canada)

Para pedir servicio de reparación a domicilio, y para ordenar piezas:

**1-888-SU-HOGAR® (1-888-784-6427)**



® Registered Trademark / ™ Trademark / ™ Service Mark of Sears Brands, LLC  
® Marca Registrada / ™ Marca de Fábrica / ™ Marca de Servicio de Sears Brands, LLC

## 90-DAY FULL WARRANTY

If this Sears Treadmill Exerciser fails due to a defect in material or workmanship within 90 days of the date of purchase, call 1-800-4-MY-HOME® (1-800-469-4663) to arrange for free repair (or replacement if repair proves impossible). The frame and drive motor are warranted for five (5) years from the date of purchase.

This warranty does not apply when the Treadmill Exerciser is used commercially or for rental purposes.

This warranty gives you specific legal rights, and you may also have other rights which vary from state to state.

**Sears, Roebuck and Co., Hoffman Estates, IL 60179**