



REFRIGERATOR RS2530B**

Write the model and serial number here:

Model # _____

Serial # _____

These numbers can be found inside on the left of the refrigerator.

OWNER'S MANUAL AND INSTALLATION

CONTENTS

<i>SAFETY WARNING SIGNS</i>	2
<i>OPERATING INSTRUCTIONS</i>	4
SETTING UP THE REFRIGERATOR	4
MAJOR FEATURES	4
CONTROL PANEL	5
DIGITAL PANEL	6
TEMPERATURE CONTROL	7
ICE and COLD WATER DISPENSER	7
SHELVES and BINS	8
FOOD STORAGE GUIDE	9
REMOVING THE FREEZER ACCESSORIES	11
REMOVING THE FRIDGE ACCESSORIES	11
CARE AND CLEANING	12
CHANGING THE INTERIOR LIGHT	13
WATER FILTER	14
DOORS	14
<i>INSTALLATION INSTRUCTIONS</i>	15
INSTALLATION OF THE REFRIGERATOR	15
REMOVING THE REFRIGERATOR DOORS	16
REATTACHING THE REFRIGERATOR DOORS	19
LEVELING THE REFRIGERATOR	22
ADJUSTING THE HEIGHT BETWEEN THE DOORS	23
CHECKING THE WATER DISPENSER LINE	24
INSTALLATION OF THE WATER DISPENSER LINE	25
BEFORE YOU CALL FOR SERVICE	28
<i>CONSUMER SUPPORT</i>	30
WARRANTY	30

In the U.S.A, for questions about features, operation/performance, parts, accessories or service, call:

1-800-726-7864 (1-800-SAMSUNG)

www.samsung.com

Register your product at www.samsung.com/global/register

DA68-01606A REV(0.0)

SAFETY WARNING SIGNS



WARNING

- Before operating the appliance, please read this manual thoroughly and retain it for your reference.
- The appliance is not intended for use by children or infirm persons without adult supervision.
- Children should be supervised to ensure that they do not play with the appliance.

CAUTION/WARNING SIGNS USED

 WARNING	Indicates that a danger of death or serious injury exists.
 CAUTION	Indicates that a risk of personal injury or material damage exists.

OTHER SIGNS USED

	Represents something you must NOT do.
	Represents something you must NOT disassemble.
	Represents something you must NOT touch.
	Represents something you must follow.
	Indicates that you must disconnect the power plug from the socket.
	Represents a ground is needed to prevent electric shock.
	It is recommended that this action be handled by a service person.

Please follow the warning signs to prevent injury to users or other persons.
 After reading the warning signs, keep them in a safe place for future reference.



WARNING SIGNS



Do not plug several appliances into the same receptacle.

- This could cause overheating and the risk of fire.

Make sure that the power plug is not squashed or damaged by the back of the refrigerator .

- A damaged power plug may overheat and cause fire.

Do not directly spray water inside or outside the refrigerator/freezer.

- There is a risk of electric shock.

Do not use aerosols near the refrigerator .

- There is a risk of explosion or fire.

Do not bend the power cord excessively or place heavy articles on it .

- This constitutes a fire hazard. If the power cord is damaged, have it replaced immediately by the manufacturer or its service agent.

Do not insert the power plug with wet hands.

- You may receive an electric shock.

Do not put a container filled with water on the refrigerator.

- If spilled, there is a risk of fire or electric shock.

Do not install the refrigerator in a damp place or a place where it may come in contact with water.

- Deteriorated insulation of the electrical parts may cause electric shock or fire.

Do not store volatile or flammable substances in the refrigerator.

- The storage of benzene, thinner, alcohol, ether, LP gas and other such products may cause explosions.



Do not disassemble or repair the refrigerator by yourself.

- You run the risk of causing a fire, malfunctions and/or personal injury.



Pull the power plug out of the socket before changing the interior light of the refrigerator.

- Otherwise, there is a risk of electric shock.



If you wish to dispose of the refrigerator / freezer throw it away after first removing the doors and seals.

- Do so in a way that it is not possible for a child to remain-trapped inside.



The refrigerator must be grounded.

- You must ground the refrigerator to prevent any power leakages or electric shocks caused by current leakage from the refrigerator.



Never use gas pipes, telephone lines or other potential lightning rods as ground.

- Improper use of the ground plug can result in a risk of electric shock. If it is necessary to use an extension cord, use only a 3-wire extension cord that has a 3-blade round plug and a 3-slot receptacle that will accept the plug on the appliance. The marked rating of the extension cord should be AC 115V-120V, 10A, or more. If a grounding adapter is used, make sure the receptacle box is fully grounded.

SAFETY WARNING SIGNS



CAUTION SIGNS



Do not overfill the refrigerator with food.

- When you open the door, an item may fall out and cause personal injury or material damage.

Do not put bottles or glass containers in the freezer

- When the contents freeze, the glass may break and cause personal injury.

If the wall socket is loose, do not insert the power plug.

- There is a risk of electric shock or fire.



Do not disconnect the power cord by pulling on it.

- Damage to the cord may cause a short-circuit, fire and/or electric shock.
- If the power cord is damaged, it must be replaced by the manufacturer, a certified service agent or qualified service personnel.

Do not store articles on the top of the appliance .

- When you open or close the door, the articles may fall and cause personal injury and/or material damage.

Do not store pharmaceutical products, scientific materials and temperature-sensitive products in the refrigerator.

- Products with require strict temperature controls must not be stored in the refrigerator.



Do not let children hang on the door, a serious injury may occur.

If you sense a strange smell or smoke, pull out the power plug immediately and contact your SAMSUNG Electronics service center.

Do not touch the inside walls of the freezer or products stored in the freezer with wet hands.

- It may cause frostbite.

Do not insert your hands into the bottom area under the appliance.

- Any sharp edges may cause personal injury.

Never put fingers or other objects into the dispenser hole and ice chute. It may cause personal injury or material damage

- In refrigerators with automatic icemakers, avoid contact with moving parts. Do not place fingers or hands on the automatic icemaking mechanism while the refrigerator is plugged in.
- Keep fingers out of the "pinch point" areas; clearances between the doors and between the doors and cabinet are necessarily small. Be careful closing doors when children are in the area.
- Do not refreeze frozen foods that have thawed completely.



Do not use a wet or damp cloth when cleaning the plug. Remove any foreign matter or dust from the power plug pins.

- Otherwise there is a risk of fire.
- If the refrigerator is disconnected from the power supply, you should wait for at least five minutes before plugging it back in.

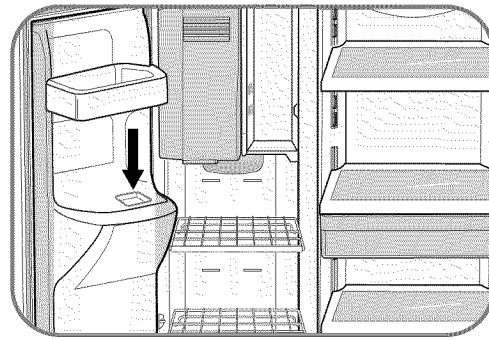

If the refrigerator is not to be used for a long period of time, pull out the power plug.

- Deterioration in the insulation may cause fire.



- The appliance is not intended for use by young children or infirm persons without supervision. Young children should be supervised to ensure that they do not play with the appliance.

- Do not place the equipment directly under the sunlight, etc

- The appliance must be positioned so that the plug is accessible after installation.

- If the power cord is damaged, it must be replaced by manufacturer, a certified service agent or qualified service personnel.

Before You Throw Away Your Old Refrigerator or Freezer:

- Take off the doors.
- Leave the shelves in place so that children may not easily climb inside.

CFC Disposal

- Your old refrigerator may have a cooling system that used CFCs (chlorofluorocarbons). CFCs are believed to harm stratospheric ozone.
- If you are throwing away your old refrigerator, make sure the CFC refrigerant is removed for proper disposal by a qualified servicer. If you intentionally release this CFC refrigerant you can be subject to fines and imprisonment under provisions of environmental legislation.



Service warranty section

- Any changes or modifications performed by a 3rd party on a finished product is not covered under Samsung warranty service

Safety Caution section

- Samsung does not recommend 3rd party modification, therefore Samsung is not responsible for safety issues that result from 3rd party modifications.



DANGER

Risk of child entrapment. Before you throw away your old refrigerator or freezer

- Take off the doors
- Leave the shelves in places so that children may not easily climb inside.

SETTING UP THE REFRIGERATOR

Once you have performed the following steps, your refrigerator should be fully operational. If not, check the power supply and electricity source. If you have any questions, contact your SAMSUNG service center.

1 Place the refrigerator in an appropriate location with reasonable clearance between the wall and the refrigerator. (refer to installation instructions in this manual)

2 When the refrigerator is plugged in, the interior light should come on when you open the doors.

3 Set the temperature control to the coldest temperature and wait for an hour. The freezer should get slightly chilled and the motor should run smoothly.

4 Once the refrigerator temperature is sufficiently low, you can store food in the refrigerator. After starting the refrigerator, it takes a few hours to reach the appropriate temperature.

5 You can arrange the Power cable with this Cable tie, after you plug in the refrigerator.

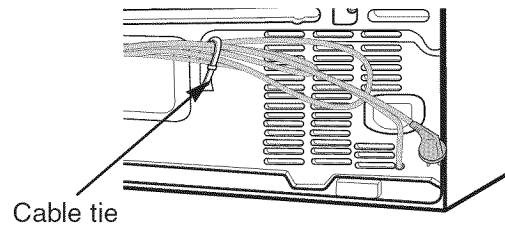

MAJOR FEATURES

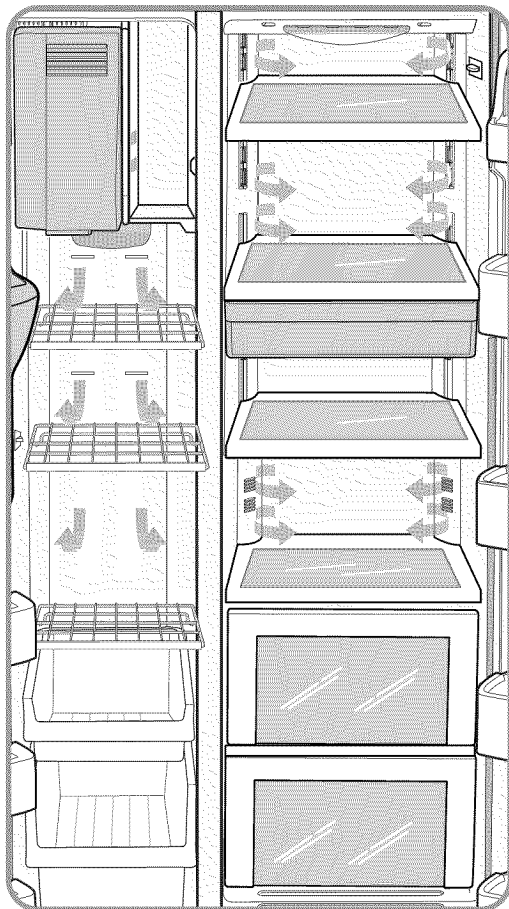

Twin X AirFlow

- Cool air circulates through side vents on every shelf level. This provides even distribution of cooling inside cabinets to keep your food fresh longer.

Xtra Space™

- Vertical room next to the ice maker in the freezer provides space for pizza etc.

Door Alarm

- Beep sound reminds you the door is open.

Vegetable Crisper

- Optimized humidity control keeps vegetables & fruits fresh.

CONTROL PANEL

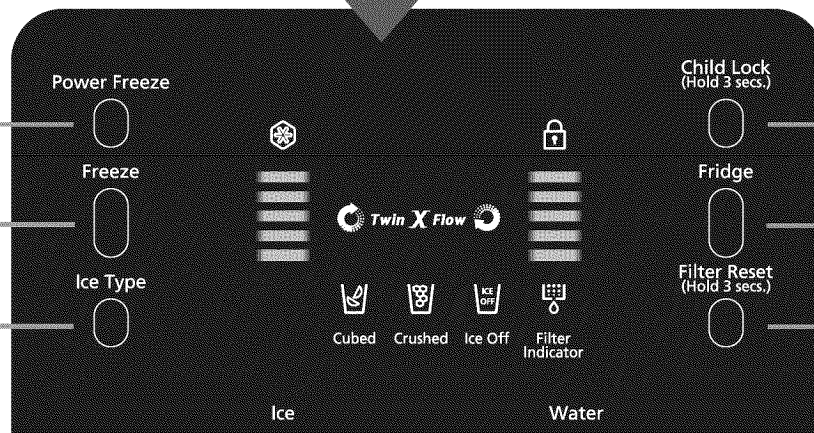
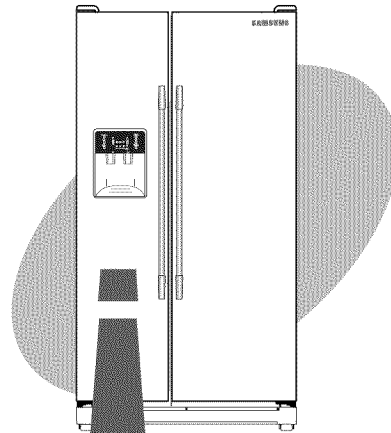

POWER FREEZE BUTTON

Speeds up the freezing process in the freezer.

FREEZER TEMP. BUTTON

To set the freezer temperature, press the button repeatedly to change the set temperature in sequence between cold and coldest.

ICE TYPE BUTTON

Use this button to choose Cubed or Crushed ice or Ice off.

CHILD LOCK BUTTON

When this button is pressed for 3 seconds, all functions are locked and can not be modified. The water and ice dispenser are locked.

FRIDGE TEMP. BUTTON

To set the fridge temperature, press the button repeatedly to change the set temperature in sequence between cool and coolest.

FILTER RESET BUTTON

When the water filter is replaced, reset the indicator by pressing the button for 3 seconds.

DIGITAL PANEL

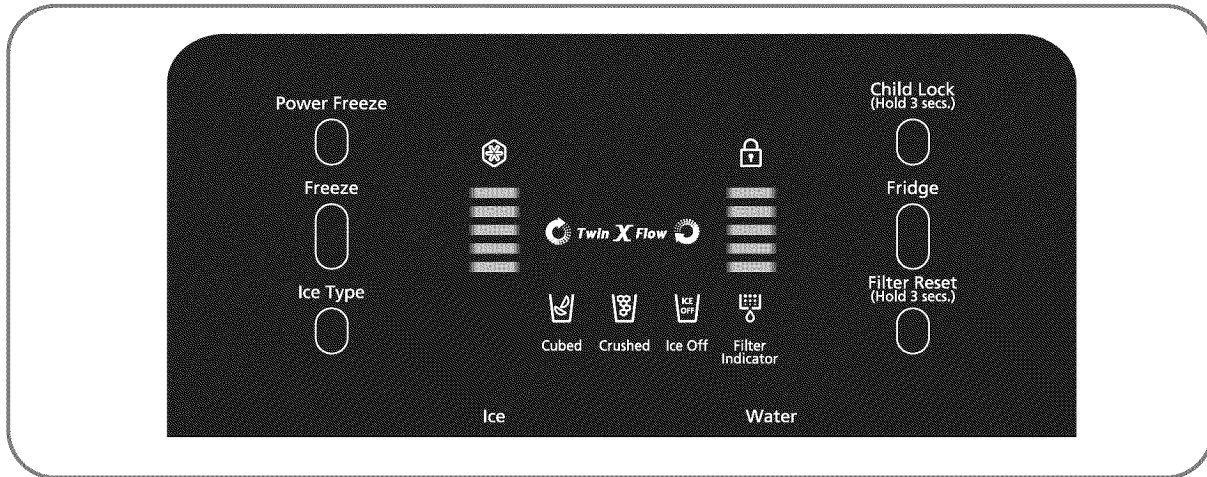

Power Freeze



- This light goes on when you press the Power Freezer button. Power Freeze speeds up the freezing process.
- If you select Power Freeze, the interior temperature of the freezer will decrease for 2 hr.30 min.
- Press the Power Freeze button again to cancel the Power Freeze function.
- This feature enables you to get ice faster.

! If you use this function, energy consumption will increase.

Cubed Ice, Crushed Ice and Ice Off

Ice Type



Cubed



Crushed



Ice Off

- Press the Ice Type button in sequence to choose Cubed Ice, Crushed Ice or Ice Off to stop making ice.
- An indicator will light to show the ice type currently chosen.

Filter Indicator



- When the green light changes to orange, it is time to replace the water filter. If the indicator is red, quick replacement is strongly recommended.
- When the water filter is replaced, reset the indicator by pressing the filter reset buttons for 3 seconds.
- To turn off this indicator off, press the filter reset buttons for 3 seconds.

Child Lock Button



- When this button is pressed for 3sec., all functions are locked and can not be modified. The water and ice dispenser are also locked.

TEMPERATURE CONTROL

Cool Down Period

- To ensure safe food storage, allow the refrigerator to operate with the doors closed for 8 to 12 hours before loading it with food.

Temperature Adjustment

- After 24 hours, adjust the controls as needed. Adjust temperature gradually: push the button in small increments, allowing the temperature to stabilize.
- Press the button(Freezer Temp or Fridge Temp) repeatedly until the desired temperature is set.
- For lower temperature, press the button(Freezer Temp or Fridge Temp) until more LEDs light (coldest).
- For higher temperature, press the button(Freezer Temp or Fridge Temp) until less LEDs light (cold).

For example:

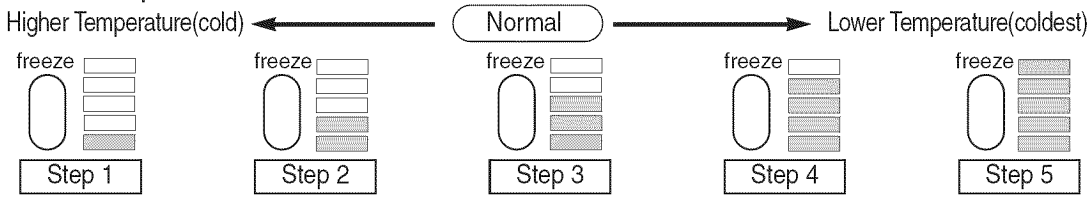

- WARNING**
- When ice cream is stored at a higher temperature than setting 2 in the Freezer, it may melt.
 - When you put ice cream back into the freezer compartment after it has been exposed to room temperature, it may harden.

ICE and COLD WATER DISPENSER

Ice Dispenser

The ice maker produces 8 cubes at once and about 120 cubes a day automatically. This quantity may be influenced by factors such as the freezer temperature, Power Freeze function and the number of door openings. When your refrigerator is plugged in, the Cubed ice mode is automatically selected .

Press the Ice Type button to select the type of ice:

- Cubed ice For Cubed ice
- Crushed ice For Crushed ice
- No ice For ice off

Push the ice dispenser lever with a cup.

- Place a cup to the dispenser lever line to prevent ice from dropping out.

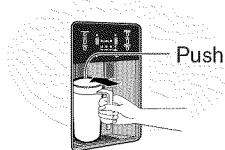

NOTE Never put fingers or any other objects in the dispenser opening. It may cause injury.

Water Dispenser

The capacity of the water tank is approximately 0.3 gal.

Cold Water

- Push the water dispenser lever with a cup.
- If you have just installed the refrigerator, throw away the first six glassfuls of water to flush out impurities in the water supply system.

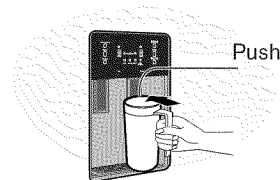

CAUTION If you won't use the water or ice dispensers for a long period of time (long vacation or business trip), close the water valve and shut off the water supply to the refrigerator. Otherwise, water leakage may occur.



Preparing for Vacation
Set the Ice Type to the ICE OFF position and shut off the water supply to the refrigerator.

SHELVES and BINS

Freezer

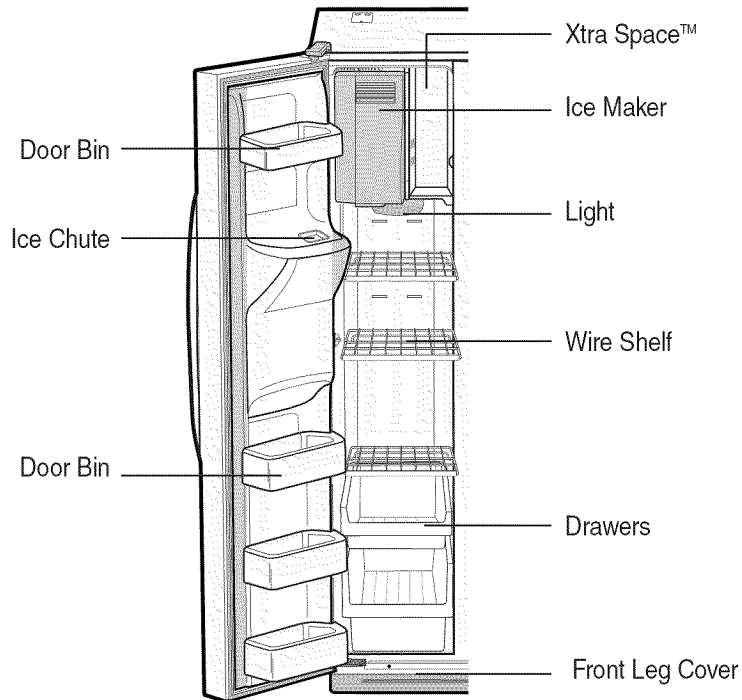

Fridge

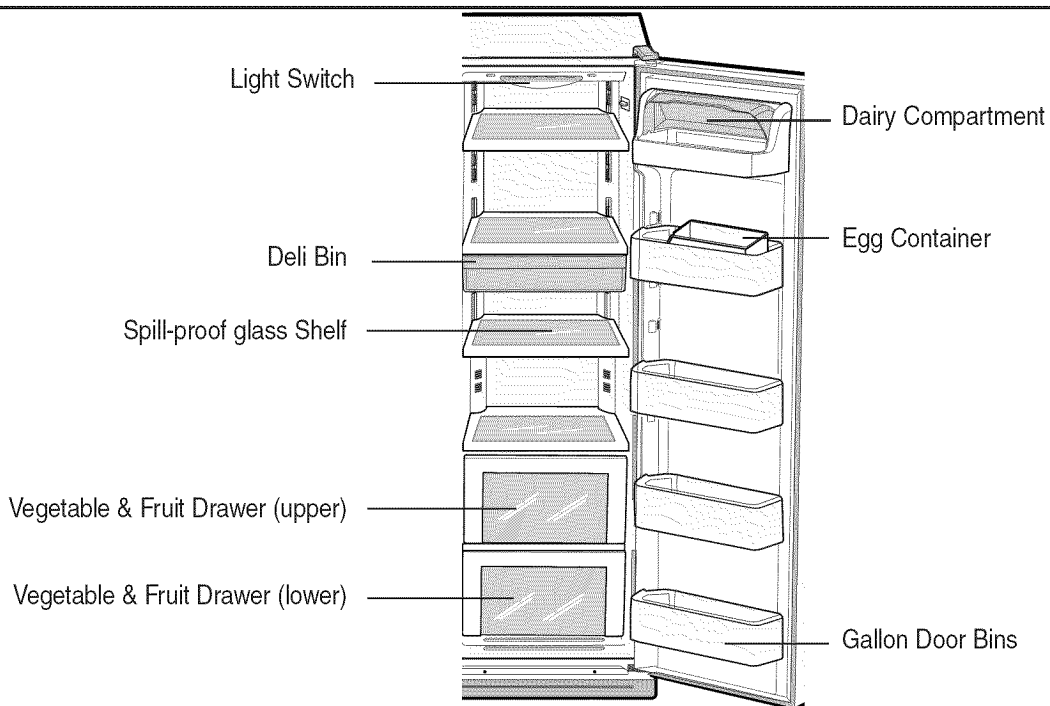

Preparing to Move

Secure all loose items such as shelves and drawers by taping them securely in place to prevent damage. When using a hand truck to move the refrigerator, do not rest the front or back of the refrigerator against the hand truck. This could damage the refrigerator. Handle only from the sides of the refrigerator. Be sure the refrigerator stays in an upright position when moving.

FOOD STORAGE GUIDE

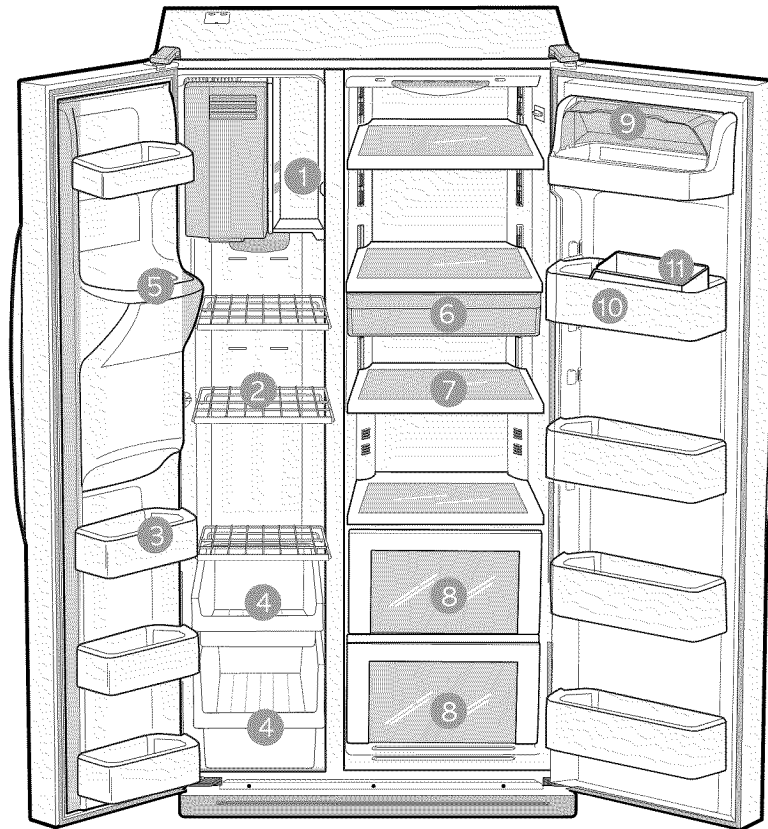

FROZEN FOOD STORAGE IN FREEZER

- 1 Xtra Space™**
- Can be used for frozen foods such as pizza, pasta, burritos, and fajitas.
 - In order to prevent odor penetration to the ice, stored food should be wrapped securely.



- 2 WireShelf**
- Can be used to store all types of frozen food.

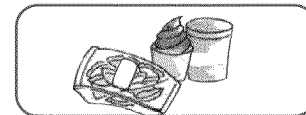

- 3 Door Bin**
- Can be used for small packages of frozen food.

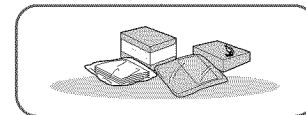

- 4 Drawer**
- Can be used to store meat and dry foods. Stored food should be wrapped securely using foil or other suitable wrapping materials or containers.

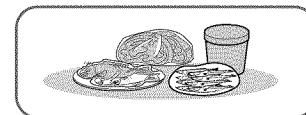

- 5 Ice chute**



Do not put your fingers, hands or any other insuitable objects in the chute or ice-maker bucket. This may result in personal injury or material damage.

FOOD STORAGE GUIDE

CHILLED FOOD STORAGE IN FRIDGE

6 Deli Bin

- Can be used to store all types of chilled food.

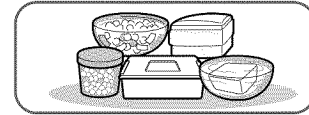

7 Tempered Spill Proof Glass Shelf

- Can be used to store all types of chilled food.
- Safe and break resistant.
- Circular marks on the glass surface are a normal phenomenon.

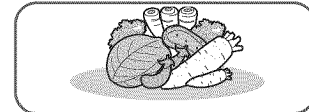
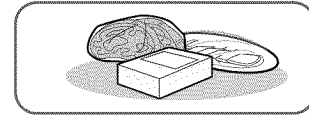

8 Fruit & Vegetable Drawer (Upper and Lower)

- Used to store fruits and vegetables.
- The drawer is airtight. Optimized humidity control design helps to preserve the freshness of stored vegetables and fruits.
- Adjust the “Optimized humidity control”, as needed.
 - To keep vegetables and fruits fresher and to help prevent drying, set the “Optimized humidity control” to “High”.
 - To reduce the time it takes to lower the temperature in the drawer, set the “Optimized humidity control” to “Low”.

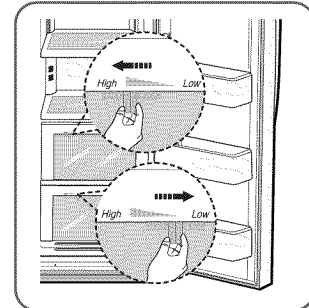
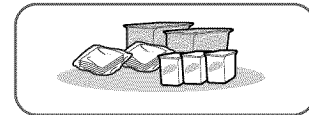

Storage Drawers

Excess water that may accumulate in the bottom of the drawers should be wiped dry.

9 Dairy Compartment

- Can be used to store butter, margarine.

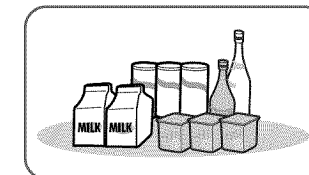

10 Gallon Door Bins

- Can be used to store foods in packages, such as milk and yogurt.

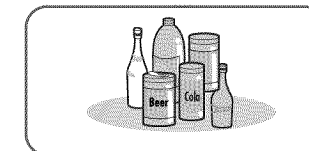

Bottles should be stored tightly together so that they do not fall out.

11 Egg Container

- Put eggs in the container and place them on the shelf.

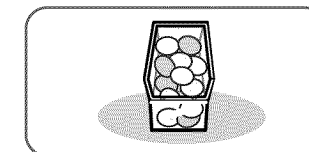

REMOVING THE FREEZER ACCESSORIES

1 Wire Shelf

- Pull the shelf out as far as it goes. Then lift it up and remove it.

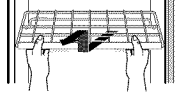

2 Door Bin

- Hold the door bin with both hands and then lift it up.

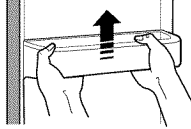

3 Drawer

- Remove the drawer by pulling it out and lifting it up slightly.

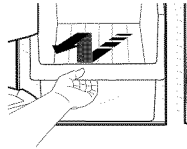

4 Ice Maker Bucket

- Remove the bucket by lifting up and pulling out.

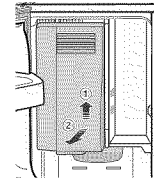

5 Front Leg Cover

- Open the freezer and fridge doors, remove three screws and detach the cover.
- To reattach the front leg cover, put it back to original position and tighten the three screws.

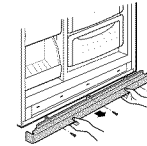

NOTE

- Do not use excessive force when removing the cover. It may cause an injury.

REMOVING THE FRIDGE ACCESSORIES

1 Spill Proof Glass Shelf

- Pull the shelf out as far as it will go. Then lift it up and gently remove it.

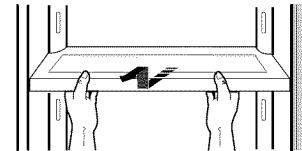

2 Vegetable & Fruit Drawer

- Remove the drawer by holding the handle, pulling the drawer out, and then lifting up the back side of the drawer bottom smoothly with the other hand.

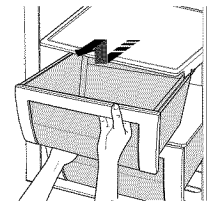

3 Deli Bin

- Remove the drawer by holding the handle, pulling the drawer out, and then lifting up the back side of the drawer bottom smoothly with the other hand.

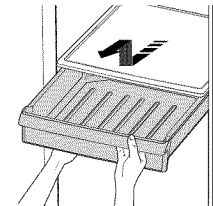

4 Gallon Door Bin

- Hold the bin with both hands and remove it by lifting it up.

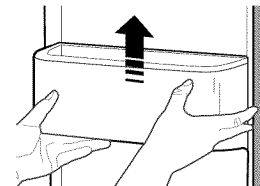

NOTE

- Before removing the freezer and fridge accessories, please remove the stored foods.

CARE AND CLEANING

Interior

- Clean the accessories with a mild detergent, then wipe out with a dry cloth.
- After washing the accessories, make sure that they are dry before using them again.

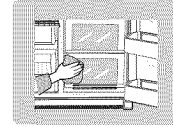

Exterior

- Wipe the digital panel and display panel with a clean cloth.
- Clean the surface of doors, handles and cabinet with a mild detergent and soft cloth, then wipe off the surface with a dry cloth.
 - Do not use Benzene, Thinner and Clorox™ for cleaning
 - Do not spray water directly on the surface of refrigerator while cleaning.
- The exterior part of refrigerator should be polished once or twice a year.

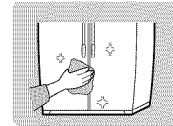

Rear

- Use a vacuum cleaner to remove dust once or twice a year.

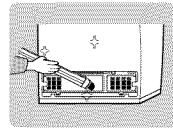

Ice and water dispenser

- Before cleaning, lock the dispenser by pressing the Child lock button. Use a damp cloth to clean the ice and water dispenser. Then wipe it out with a dry cloth.
- To keep the drainage grid dry, do not touch the ice and water dispenser without a cup or glass in place.

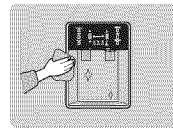

Rubber door seals

- If the rubber door seals are dirty, the door will not close properly, The refrigerator will not be able to function efficiently. Clean the doors with a mild detergent and damp cloth. Then wipe with a dry cloth.

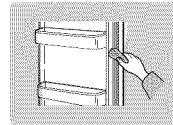

WARNING

- Do not spray the refrigerator with water. It may cause an electric shock.
- Do not clean it with benzene, thinner or car detergent. It may cause a fire.

CHANGING THE INTERIOR LIGHT



Before changing the interior lights, unplug the refrigerator from the power supply. If you have difficulty in changing the lights, contact your service center.



• Light bulbs may be hot.



INTERIOR LIGHT IN THE FRIDGE

- 1** Place a flat screwdriver under the light cover hooks and remove it by pushing and lifting in the direction of the arrow.

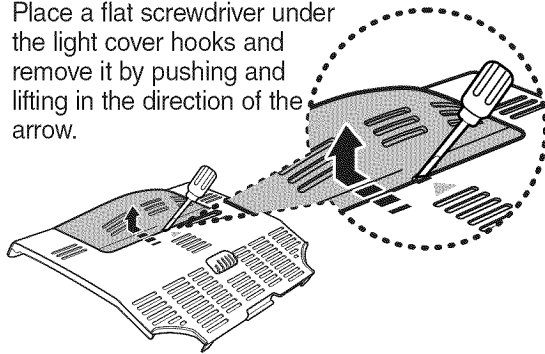

- 2** After changing the bulb, reattach the light cover.

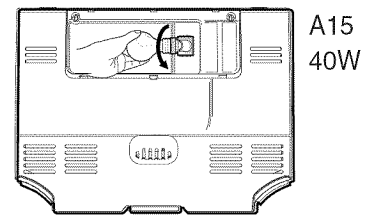

• Replacement bulbs for both the freezer and fridge are at available retail outlets such as Wal-mart, The Home Depot and Lowe's.
Use replacement bulb size A15, maximum 40 watts.



INTERIOR LIGHT IN THE FREEZER

The freezer light is located in the bottom of the auger motor case.

- 1** Use a screwdriver to remove the light cover (1).

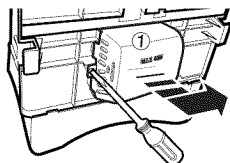

- 2** Replace the bulb with a new one (2).

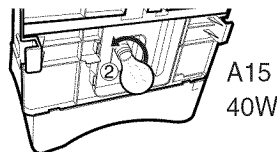

- 3** Reattach the light cover.

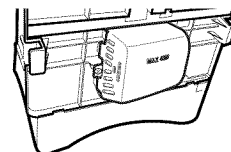

• Replacement bulbs for both the freezer and fridge are at available retail outlets such as Wal-mart, The Home Depot and Lowe's.
Use replacement bulb size A15, maximum 40 watts.

WATER FILTER

The water “Filter Indicator” light

- “Filter Indicator” light lets you know when it is time to change your water filter cartridge. The light will change from green to orange. This tells you that it is almost time to change the current cartridge. It is recommended that you replace the cartridge when the light changes to red or every six months. (see “Install the water filter” section on the page 26 for more information.)

Using the dispenser without the water filter

- You can not use the water and ice dispenser without a water filter cartridge because the water line blocks at the water supply.

Ordering replacement filters

- To order more water filter cartridges, call 1-800-SAMSUNG and ask for accessory Part # DA29-00003A or contact your authorized Samsung dealer.

DOORS

The refrigerator doors have a special door opening and closing feature to make sure they close all the way and are securely sealed.

When opening the door, it will only open so far. After reaching a certain point, it will remain open.

When the door is partially open, it will close automatically.

INSTALLATION OF THE REFRIGERATOR



Checking the Dimensions of your Entrance Door

Check the dimensions of your entrance door to determine whether the refrigerator can pass through it.

Model		RS2530B**	
Capacity (Cu. Ft)		24.8	
Dimension (inches)	Width		35.9"
	Case Height	without hinge	68.7"
		with hinge	70"
	Depth	with handle	34.8"
without door		28.9"	



Selecting the Location for the Refrigerator

- Select a location with easy access to the water supply.
- Select a location with enough space for the refrigerator.
- Select a location without direct exposure to sunlight.



NOTE

- Before disassembling the freezer door, the water supply line needs to be disconnected. (If not, the water supply line may be damaged.)
- See “Separating the water supply line from the refrigerator” on the next page.

Allow sufficient space to circulate the air at the internal cooling system.

- When the refrigerator doesn't have enough space, the internal cooling system may not work correctly.

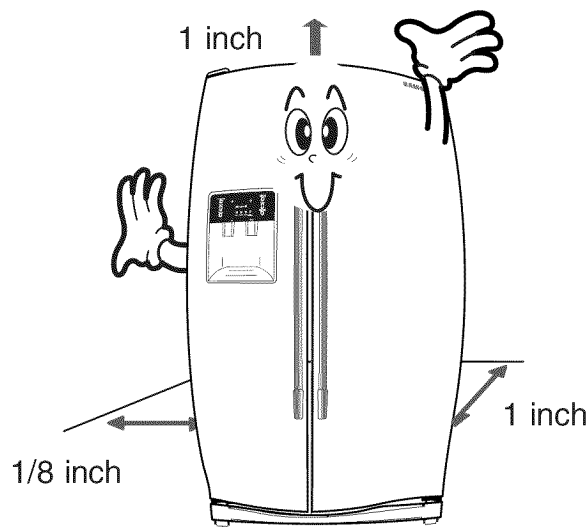

NOTE

- Allow clearance to the right, left, back and top when installing the refrigerator. This has the advantage of reducing power consumption.
- Do not install the refrigerator where the temperature will go below 50°F(10°C).

REMOVING THE REFRIGERATOR DOORS



Removing the Front Leg Cover

Open the freezer and fridge doors, and then take off the front leg cover by turning the three screws counter-clockwise.

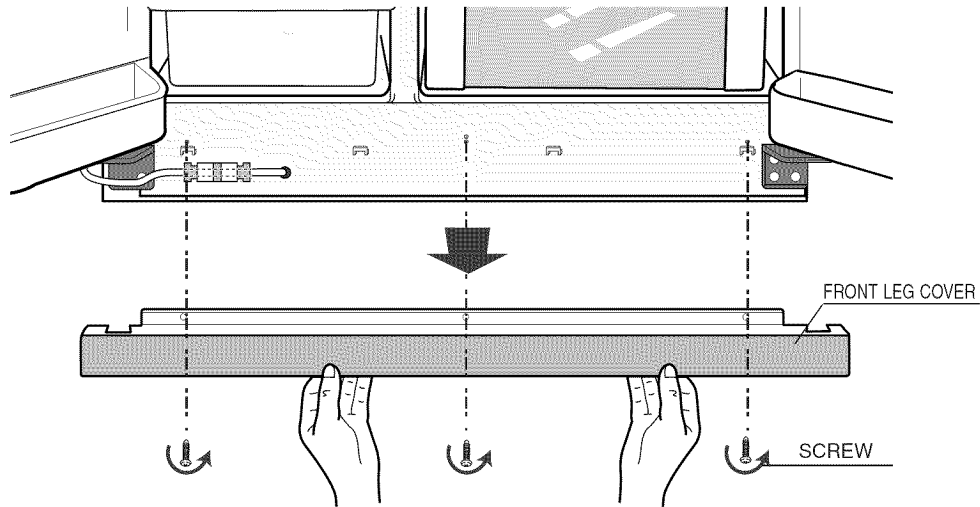

Separating the Water Supply Line from the Refrigerator

Remove the water tube by pressing the coupler (②) and pulling the water tube (①) away.

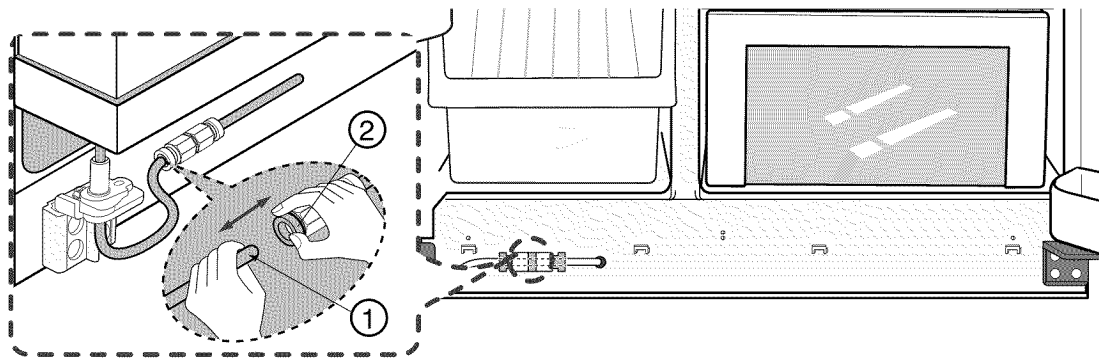

NOTE

Be careful not to cut the water tube when separating it from the coupler.

REMOVING THE REFRIGERATOR DOORS



- Lift the door straight up.
- Be careful not to pinch the water tubing and wire harness on the door.
- Place doors on a protected surface.



Removing the Freezer Door



CAUTION

Unplug the refrigerator before removing the doors.

- 1) With the door closed, remove the upper hinge cover (①) using a screwdriver, and then disconnect the wires (②)

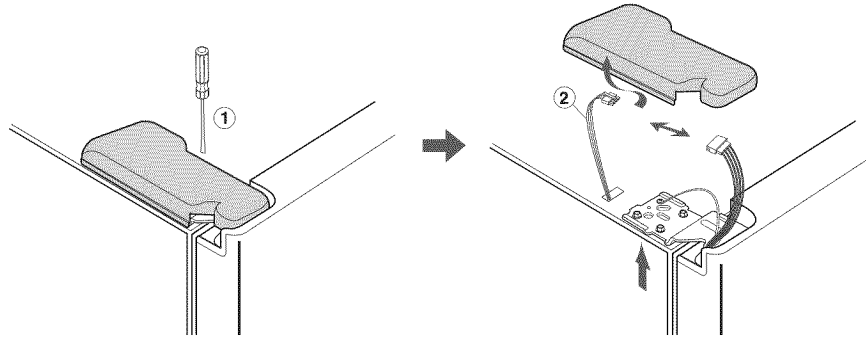

- 2) Remove hinge screws (③) and ground screw (④) counter-clockwise, and take off the upper hinge (⑤) in the direction of the arrow (⑥). Be careful when removing the door to ensure that it does not fall on you.

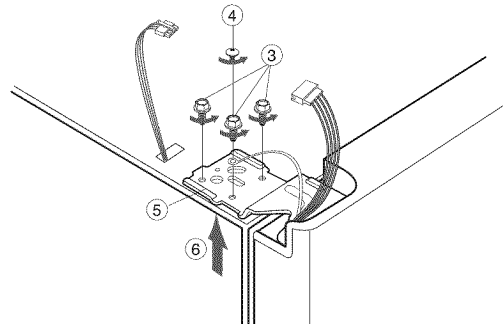

- 3) Remove the door from the lower hinge (⑦) by carefully lifting the door (⑧).

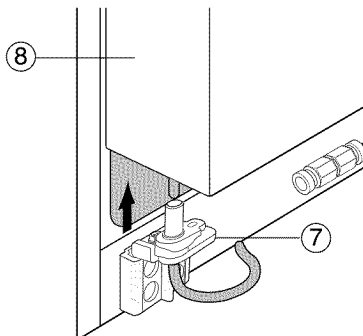

- 4) Remove the lower hinge (⑨) from the bracket lower hinge (⑩) by lifting the lower hinge (⑩) in the direction of the arrow.

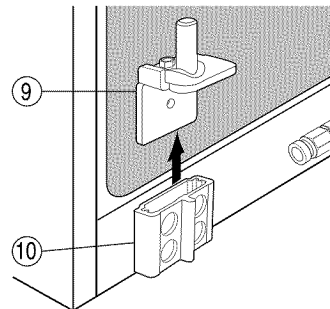

Be careful not to pinch the water tubing and the wire harness at the bottom of the door.

REMOVING THE REFRIGERATOR DOORS



Removing the Fridge Door



Unplug the refrigerator before removing the doors.

- 1) With the door closed, remove the upper hinge cover (①) using a screwdriver

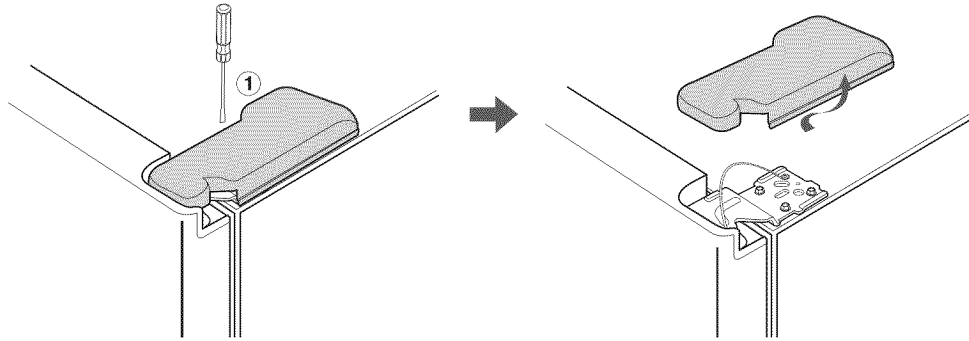

- 2) Remove hinge screws (②) and ground screw (③) counter-clockwise, and take off the upper hinge (④) in the direction of the arrow (⑤). Be careful when removing the door to ensure that it does not fall on you.

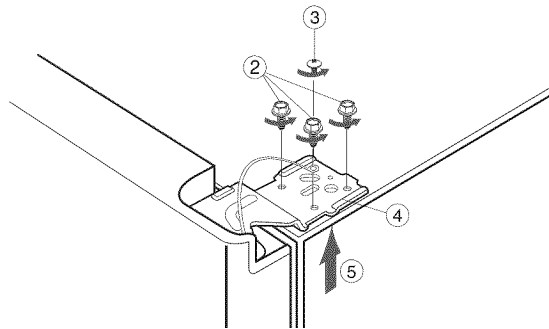

- 3) Remove the door from the lower hinge (⑥) by lifting the door (⑦).

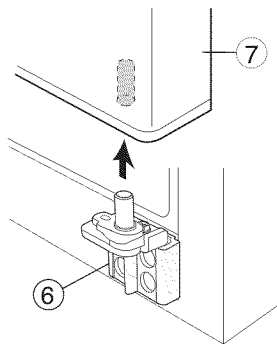

- 4) Remove the lower hinge (⑧) from the bracket (⑨) by lifting the lower hinge (⑧).

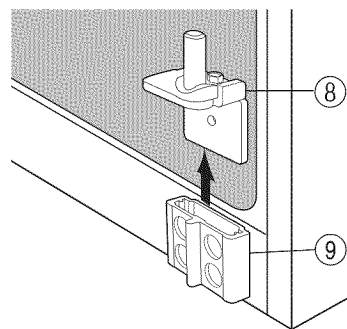

REATTACHING THE REFRIGERATOR DOORS



Reattaching the Freezer Door

1) Insert the lower hinge (①) in the bracket lower hinge (②).

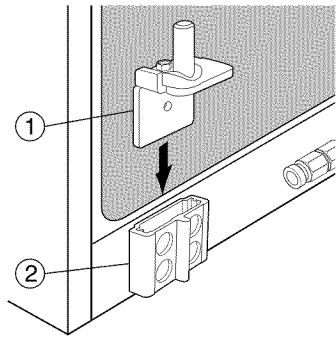

2) Before reattaching the freezer door, insert the hose (③) in the lower side of the door into the hole in the lower hinge (④) and pull the hose down. Lower the door onto the lower hinge (④).

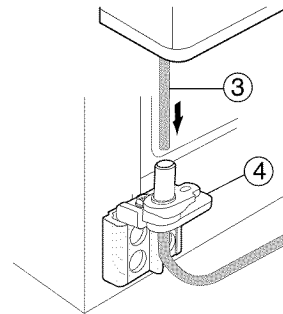

3) Insert the upper hinge shaft (⑤) into the hole on the top of the door (⑥). After levelling between the upper hinge hole (⑦) and cabinet hole (⑧), reattach the hinge screws (⑨) and ground screw (⑩) in a clockwise direction.

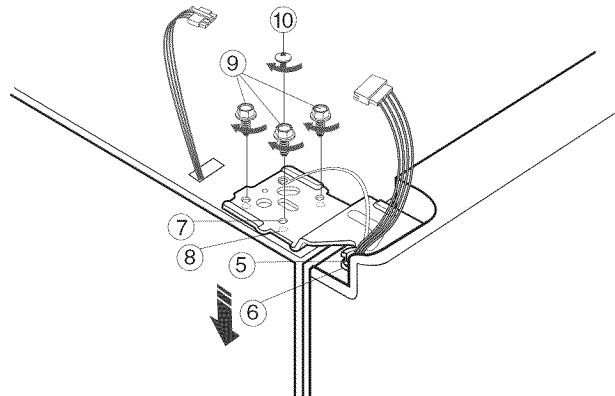

4) Connect the wires.

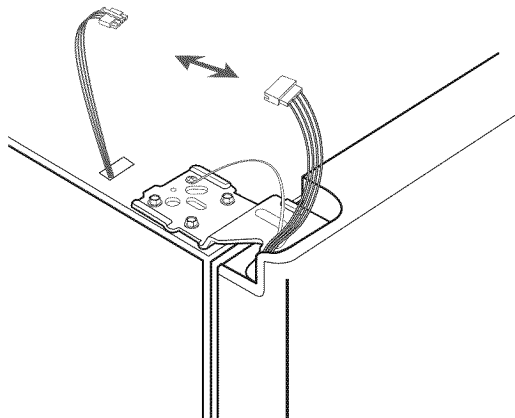

5) Put the front part of the upper hinge cover (⑨) on the front part of the upper hinge (⑩) and reattach from the front part of the upper hinge cover first.

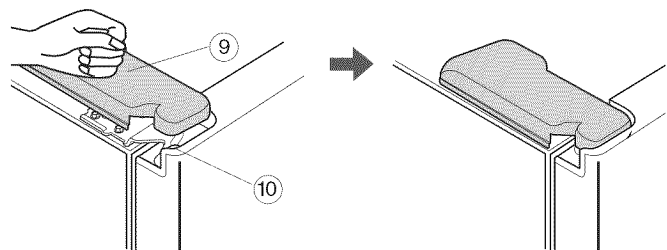

REATTACHING THE REFRIGERATOR DOORS



Reattaching the Fridge Door

1) Insert the lower hinge (①) in the bracket lower hinge (②).

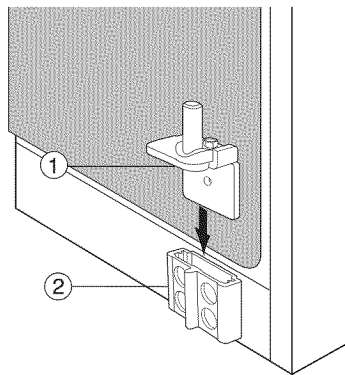

2) Place the hole in the fridge door (③) over the lower hinge (④).

Lower the door onto the hinge.

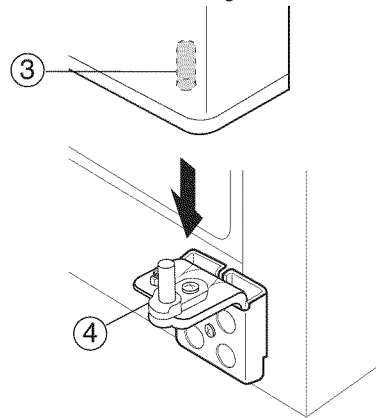

3) Insert the upper hinge shaft (⑤) into the hole at the top of the door (⑥). After levelling between the upper hinge hole (⑦) and cabinet hole (⑧), reattach the hinge screws (⑨) and ground screw (⑩) in the clockwise direction.

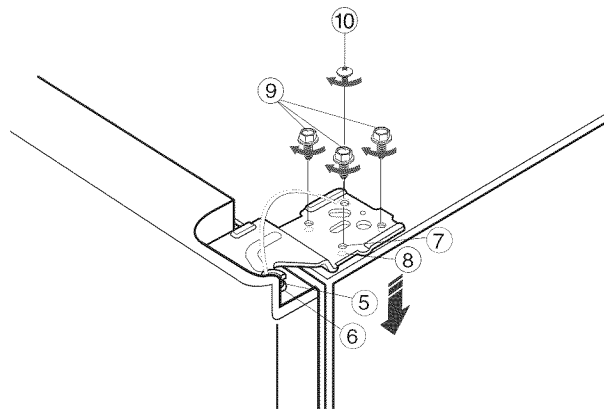

4) Connect the wire.

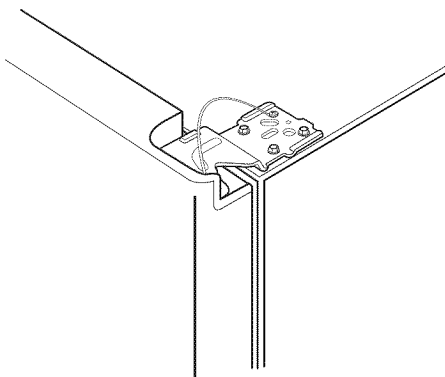

5) Put the front part of the upper hinge cover (⑪) on the front part of the upper hinge (⑫) and reattach it from the front part of the upper hinge cover first.

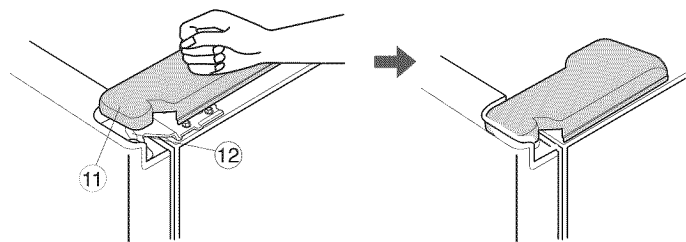

REATTACHING THE REFRIGERATOR DOORS



Reattaching the Water Supply Line

While pressing the front face of coupler (②), insert the water line (①) in the coupler. Carefully place front cover and push to snap it into position.

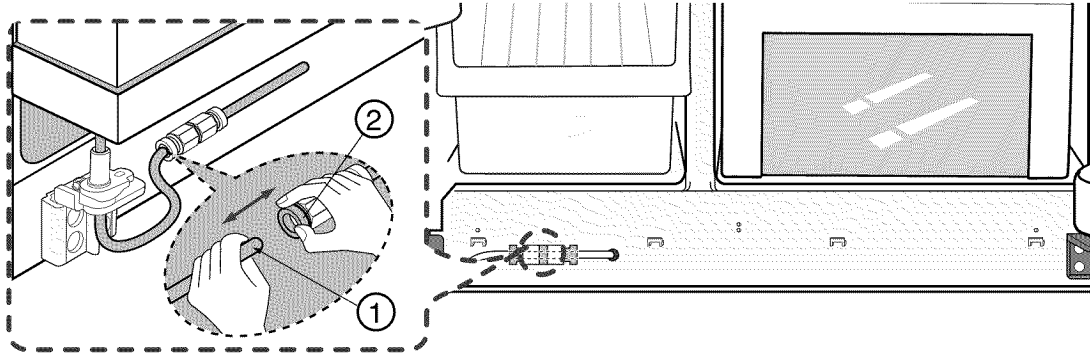

1) Push the "A" collar into the "B" body and hold.

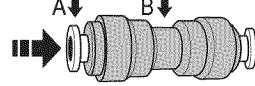

Then pull tube from the connector.

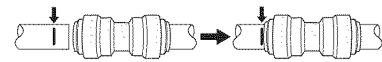

NOTE Tube must be fully inserted to the marked line to avoid leaks.



Reattaching the Front Leg Cover

Put on the front leg cover by turning the three screws clockwise, as shown in the figure.



NOTE Before attaching check water connector, be sure to check for leakage.

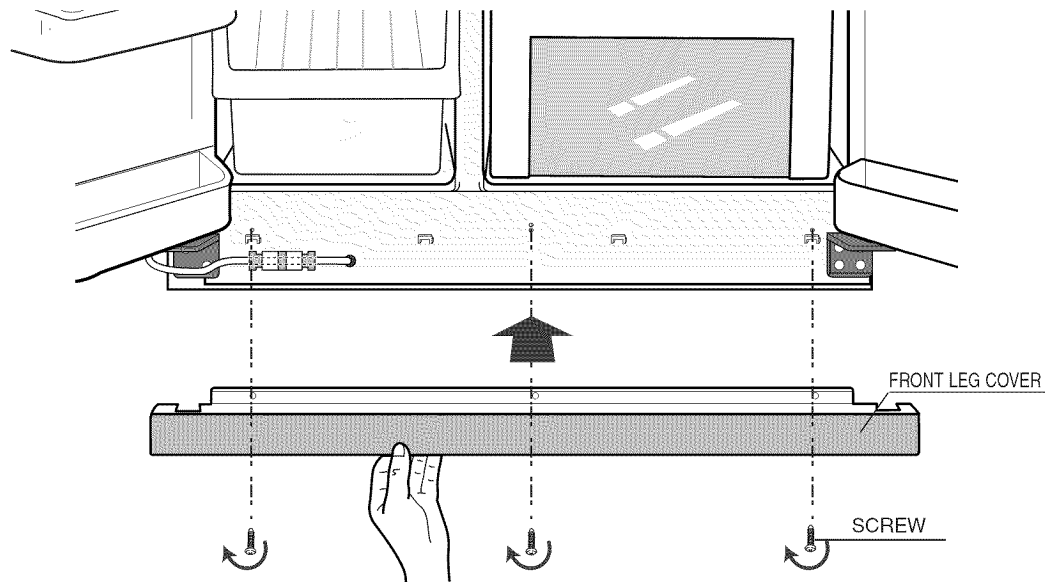

LEVELING THE REFRIGERATOR



Please level the refrigerator first.

The doors will be uneven if the refrigerator is not level.

Case 1) Freezer door is lower than the fridge door.

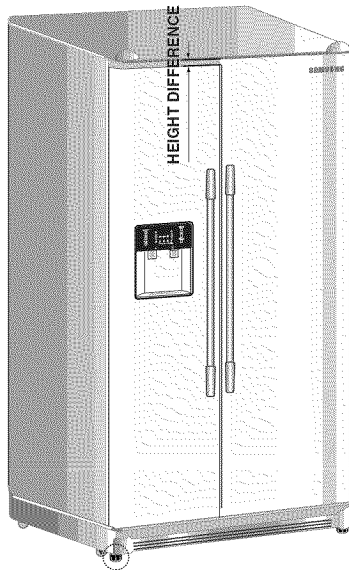

Insert a flat-blade screwdriver (-) (①) into a slot of the control lever (②), turn it clockwise and level the refrigerator.

① SCREW DRIVER(-)

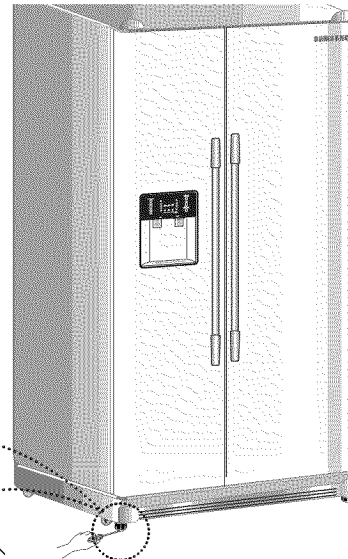
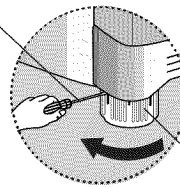

② CONTROL LEVER

Case 2) Freezer door is higher than the fridge door

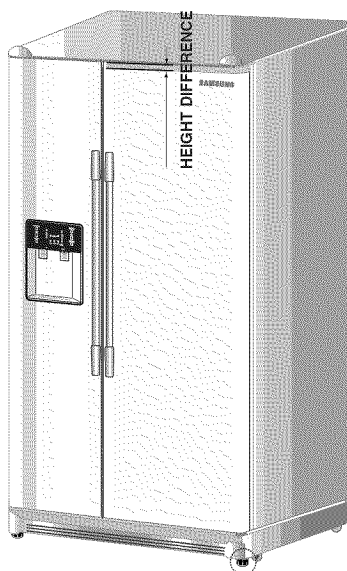

Insert a flat-blade screwdriver (-) (①) into a slot of the control lever (②), turn it clockwise and level the refrigerator.

① SCREW DRIVER(-)

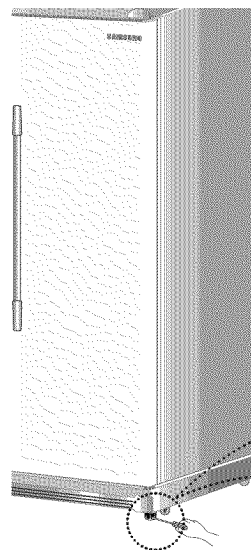

② CONTROL LEVER



Do not make small adjustments with the control lever, please refer to the next page.

ADJUSTING THE HEIGHT BETWEEN THE DOORS



Making small level adjustments between doors.

If the door of the freezer is lower than that of the fridge.

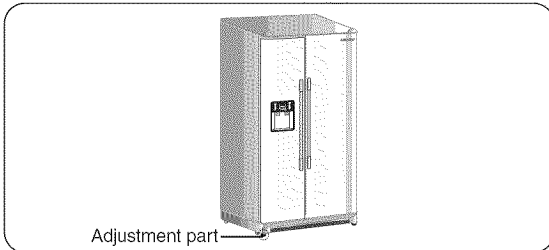

If the door of freezer is higher than that of the fridge.

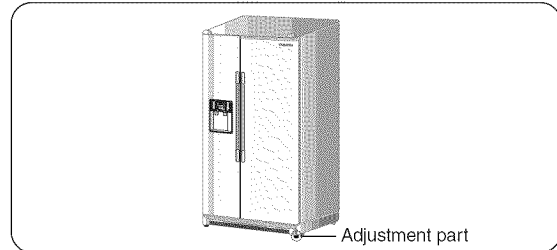

Please open the doors and adjust them as follows:

- 1) Release the nut (①) on the lower hinge until it reaches the upper end of the bolt (②).



NOTE

When you release the nut (①), use enclosed hex wrench (③) to turn the bolt (②) in a slightly counterclockwise direction. This will enable you to loosen the nut (①) with your fingers.

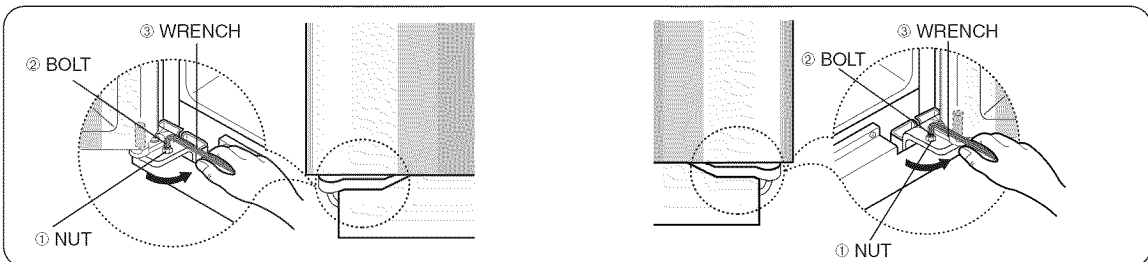

- 2) Please adjust the height difference between the doors by turning the bolt (②) clockwise (↻) or counter clockwise (↻).



NOTE

When you turn clockwise (↻), the door goes up.

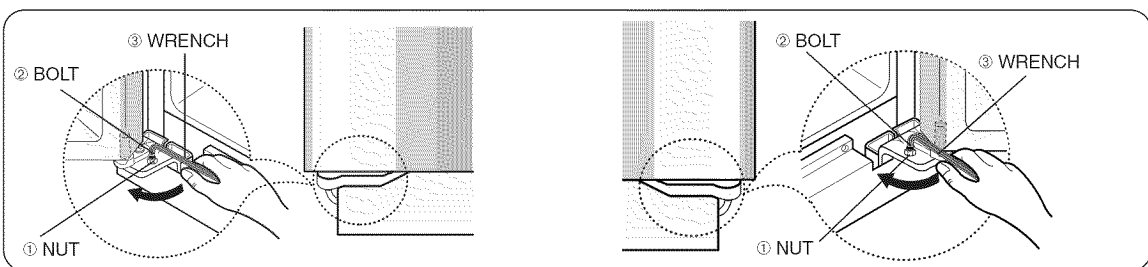

- 3) After adjusting the doors, turn the nut clockwise (↻) until it reaches the lower end of the bolt, then tighten the bolt again with the wrench (③) to fix the nut (①).

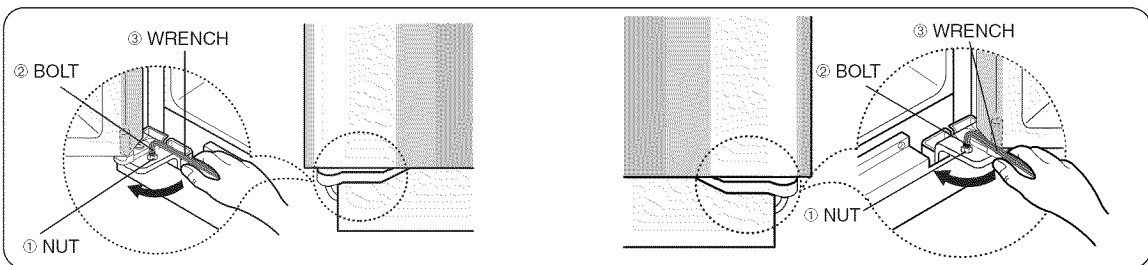

NOTE

If you do not fix the nut (①) firmly, the bolt (②) may be released.

CHECKING THE WATER DISPENSER LINE

- 1) In order to operate the ice maker properly, water pressure of 20~125 psi(0.138~0.862 Mpa) is required. In this range, a 6 oz paper cup can be filled in 10 secs.
- 2) The water filter removes particles. It does not sterilize or destroy any micro-organisms.
- 3) If the refrigerator is installed in area with low water pressure (below 20psi), you should install a booster pump to compensate for the low pressure.
- 4) Ensure the water storage tank inside the refrigerator is filled. Push the water dispenser lever until the water runs from the outlet.



Water line installation kit is available at extra cost from your dealer. The refrigerator manufacturer recommends using a water supply kit containing copper tubing.



Connecting to water supply line

- Shut off the main water supply line and turn the Ice maker to the off position.
- Locate the nearest cold water line.
- Follow the instructions in the ice maker installation kit.
- After connecting the water supply with water filter, turn on water supply and flush 4 or more gallons into a bucket to clear the water filter.

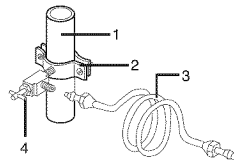

1. Cold Water line.
2. Pipe Clamp.
3. Water Line Installation Kit.
4. Shut Off Valve.

INSTALLATION OF THE WATER DISPENSER LINE



Before You Install the water line

- This water line installation is not warranted by Samsung. Follow these instructions carefully to minimize the risk of expensive water damage.
- Banging pipes (water banging in the pipes) in house plumbing can cause damage to refrigerator parts and lead to water leakage or flooding. Call a qualified plumber to correct the problem before installing the water supply line to the refrigerator.
- To prevent burns and product damage, do not hook up the water line to the hot water line.
- If you use your refrigerator before connecting the water line, make sure the "Ice Type" is set to the ICE OFF position.
- Do not install the icemaker tubing in areas where temperatures fall below freezing.
- When using any electrical device (such as a power drill) during installation, be sure the device is insulated or wired in a manner to prevent electric shock.
- All installations must be in accordance with local plumbing code requirements.



Connect the water tube to the refrigerator.

- 1) Slip the compression nut through the provided plastic tubing.
- 2) Tighten the compression nut onto the 1/4" compression fitting.



NOTE Do not overtighten the compression nut.

- Using Copper Tubing
 - Slip the compression nut and ferrule on copper tubing as shown.
 - Using Plastic Tubing
 - Insert the molded end of the plastic tubing into the compression fitting.
- 3) Tighten the compression nut onto the compression fitting.
 - 4) Turn water on and check for any leakage.

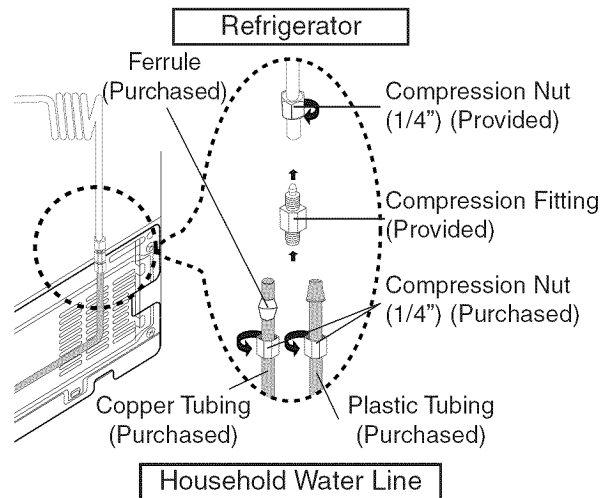

NOTE Water line must be connected to drinkable water only. Cut off 1/4 inch of the provided plastic tubing squarely to prevent leaks when reconnecting.

INSTALLATION OF THE WATER DISPENSER LINE



Install the water filter.



NOTE The water filter is located in the extra space behind the Deli Bin.

- 1) Remove the fixed cap (A) as shown. the fixed cap separates from the Water Filter Compartment by rotating it as shown.
Remove the water filter from the box and put a month indicator stick on the filter as shown.

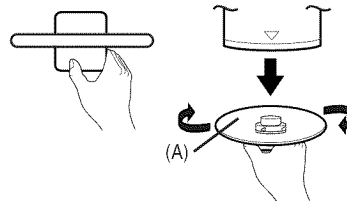

NOTE Keep the cap(A) in a safe place for recapping, when you don't need to use the filter.

- 2) If the water filter was installed in March, put on the "SEP" sticker.
- 3) Remove the Red protective cap from the filter, then position and insert the filter as shown.
- 4) Slowly turn the water filter as shown below to align the indication mark on the cover, locking the filter in position. Do not overtighten.

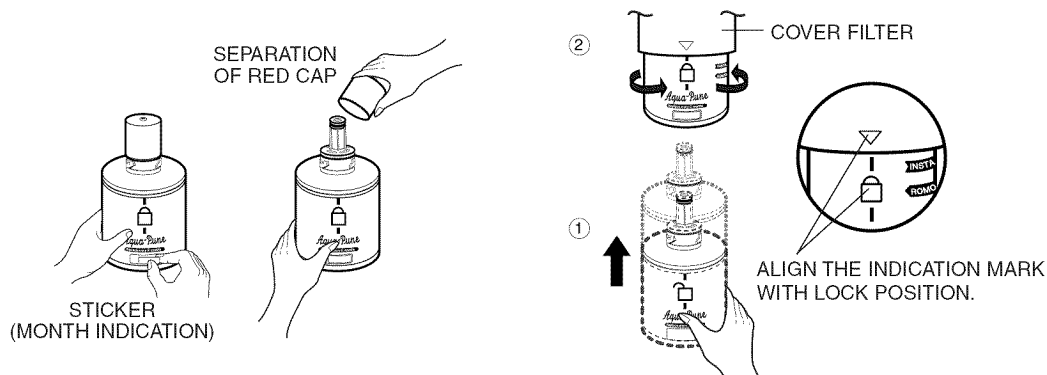

• Please check that the indication line aligns with the lock position.



Remove any residual matter inside the water supply line after installing filter.

- 1) Turn on the main water supply & shut-off valve of the water supply line.
- 2) Run water through the dispenser until the water runs clear (6~7 minutes). This will clean the water supply system and clear air from the lines.
- 3) Additional flushing may be required in some households.
- 4) Open the refrigerator door and check if water leaks around the water filter.

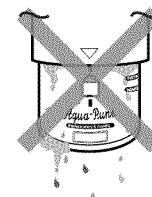
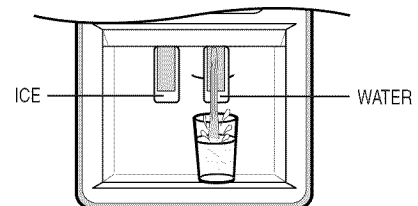

• A newly-installed water filter cartridge may cause water to briefly spurt from the dispenser.

INSTALLATION OF THE WATER DISPENSER LINE



Check the amount of water supplied to the ice tray.

- 1) **To remove** : Set the "Ice Type" switch to the Ice off position. Lift up ① and pull out ② the icemaker bucket in the freezer.

To replace : When replacing the drawer, be sure to press it firmly into place. If it does not go all the way back, remove it and rotate the drive mechanism 1/4 turn. Then push the drawer back again.

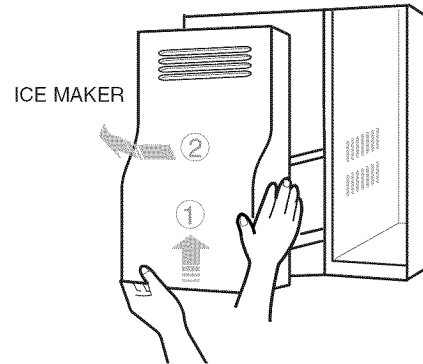

- 2) Throw away the first few batches of ice to allow the water line to clear.

Be sure nothing interferes with the sweep of the feeler arm.

When the bin fills to the level of the feeler arm, the icemaker will stop producing ice.

It is normal for several cubes to be joined together.

If ice is not used frequently, old ice cubes will become cloudy, taste stale and shrink.

- 3) **Important Facts About Your Dispenser** :

Do not add ice from trays or bags to the storage bin. It may not crush or dispense well.

Avoid overfilling glass with ice and use of narrow or extra-tall glasses. Backed-up ice can jam the chute or cause the door in the chute to freeze shut. If ice is blocking the chute, poke it through with a wooden spoon.

Beverages and foods should not be quick-chilled in the ice storage bin.

To keep dispensed ice from missing the glass, put the glass close to, but not touching, the dispenser opening.

Some crushed ice may be dispensed even though you selected CUBES. This happens occasionally when a few cubes accidentally get directed to the crusher.

After crushed ice is dispensed, some water may drip from the chute.

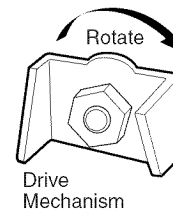
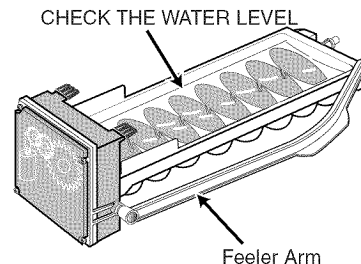

- 4) **Water Supply to the Icemaker** :

The icemaker must be connected to a cold water line.

- 5) **Start the Icemaker** :

Set the "Ice Type" to the "Cubed Ice" or "Crushed Ice" position. The icemaker will not begin to operate until it reaches its operating temperature of 10.4°F (-12°C) or below. It will then begin operation automatically if the "Ice Type" is in the "Cubed Ice" or "Crushed Ice" position.



NOTE

- If there is no water supply, turn off the icemaker to save energy.
- In lower water pressure conditions, the water valve may turn on up to 3 times to make sure enough water reaches the icemaker.

BEFORE YOU CALL FOR SERVICE...

Problem	Possible Causes	What To Do
The refrigerator does not work sufficiently or at all	• Disconnected power plug	• Check that the power plug is properly connected.
	• Is the temperature control on the display panel set to the correct temperature?	• Try setting it to a lower temperature.
	• Is the refrigerator in direct sunlight or located near a heat source?	• Move the refrigerator to a proper location.
	• Is the back of the refrigerator too close to the wall?	
The food in the refrigerator is frozen	• Is the temperature control on the display panel set to the correct temperature?	• Try setting it to a warmer temperature.
	• Is the temperature in the room too low?	
	• Did you store the food with a high water content in the coldest part of the refrigerator.	
Unusual noises or sounds are heard		• Check that the floor is levelled and stable.
	• Is the back of the refrigerator too near to the wall?	• Move the refrigerator to the proper location.
	• Was anything dropped behind or under the refrigerator?	• Remove the foreign object.
	• A “ticking” sound may be heard from inside the refrigerator. This is normal and occurs because various accessories contract or expand.	
The front corners and sides of the cabinet are hot; condensation occurs	• A pair of heat transfer pipes are installed in the front corners of the refrigerator to dissipate heat generated during the refrigeration process.	• Normal state
	• Condensation can occur when you leave the door open for a long time.	• Normal state
Ice is not dispensed	• Did you stop the ice making function?	• Check the control panel.
	• Is there any ice in the storage unit?	• Check the ice container.
	• Is the water pipe connected and the shut-off valve open?	• Check the valve.
	• Is the freezer temperature too warm?	• Set the temperature lower.
	• Did you wait for 12 hours after installation of the water supply line before making ice?	
You can hear water bubbling in the refrigerator	• The bubbling comes from the refrigerant circulating in the refrigerator and is normal.	• Normal state
There is a bad smell in the refrigerator	• Wrap strong smelling food so that it is airtight. Throw away any rotten food.	
Frost forms on the wall of the freezer		• Allow sufficient space between stored food for efficient air circulation.
	• Is the air vent blocked?	
	• Is the door closed properly?	
No water is supplied	• Is the water pipe connected and the shut-off valve open?	
	• Is the water supply pipe crushed?	
	• Is the water tank frozen because the refrigerator temperature is too low?	• Select a warmer setting on the display panel.

BEFORE YOU CALL FOR SERVICE...

Problem	Possible Causes	What To Do
Small or hollow cubes	Water filter clogged.	• Replace filter cartridge with new cartridge or with plug.
	Door left open.	• Check to see if package is holding door open.
Slow ice cube freezing	Temperature control not set cold enough.	• Check the control.
Orange glow in the freezer	Defrost heater is on.	• This is normal.
Cube dispenser does not work (on some models)	Icemaker turned off or water supply turned off.	• Turn on icemaker or water supply.
	Ice cubes are frozen to icemaker feeler arm.	• Remove cubes and move the feeler arm to the ON position.
	Irregular ice clumps in storage container.	• Break up with fingertip pressure and discard remaining clumps. • Freezer may be too warm. Adjust the freezer control to a colder setting, one position at a time, until clumps do not form.
	Dispenser is LOCKED.	• Press and hold the CHILD LOCK for 3 seconds.
Water has poor taste/odor	Water dispenser has not been used for a long time.	• Dispense water until all water in system is replenished.
Water in first glass is warm	Normal when refrigerator is first installed.	• Wait 24 hours for the refrigerator to completely cool down.
	Water dispenser has not been used for a long time.	• Dispense water until all water in system is replenished.
	Water system has been drained.	• Allow several hours for replenished supply to chill.
Water dispenser does not work	Water supply line turned off or not connected.	• See Installing the water line on page 25.
	Water filter clogged.	• Replace filter cartridge or remove filter and install plug.
	Air may be trapped in the water system.	• Press the dispenser arm for at least two minutes.
	Dispenser is LOCKED.	• Press and hold the CHILD LOCK pad for 3 seconds.
Water spurting from dispenser Water is not dispensed but icemaker is working	Newly-installed filter cartridge.	• Run water from the dispenser for 3 minutes (about one and a half gallons).
	Water in reservoir is frozen.	• Call for service.
	Refrigerator control setting is too cold.	• Set to a warmer setting.
Water on kitchen floor or on bottom of freezer	Drain in the bottom of the freezer clogged.	• See Care and Cleaning on page 12. • Check the filter lock.
	Cubes jammed in chute.	• Poke ice through with a wooden spoon.
No water or ice cube production	Supply line or shutoff valve is clogged.	• Call a plumber.
	Water filter clogged.	• Replace filter cartridge or remove filter and install plug.
	Dispenser is LOCKED.	• Press and hold the CHILD LOCK pad for 3 seconds.

SAMSUNG REFRIGERATOR

LIMITED WARRANTY TO ORIGINAL PURCHASER

This SAMSUNG brand product, as supplied and distributed by Samsung Electronics America, Inc. (SAMSUNG) and delivered new, in the original carton to the original consumer purchaser, is warranted by SAMSUNG against manufacturing defects in materials and workmanship for a limited warranty period of:

**One (1) Year Parts and Labor on Refrigerator and Homepad Terminal
Five (5) Years Parts and Labor on Sealed Refrigeration System Only*
(*Compressor, evaporator, condenser, drier, connecting tubing)**

This limited warranty begins on the original date of purchase, and is valid only on products purchased and used in the United States. To receive warranty service, the purchaser must contact SAMSUNG for problem determination and service procedures. Warranty service can only be performed by a SAMSUNG authorized service center. The original dated bill of sale must be presented upon request as proof of purchase to SAMSUNG or SAMSUNG's authorized service center.

SAMSUNG will repair or replace any part found to be defective, at our option and at no charge as stipulated herein, with new or reconditioned parts during the limited warranty period specified above. All replaced parts and products become the property of SAMSUNG and must be returned to SAMSUNG. Replacement parts and products assume the remaining original warranty, or ninety (90) days, whichever is longer.

In-home service will be provided during the warranty labor period subject to availability within the contiguous United States. In-home service is not available in all areas. To receive in-home service, the product must be unobstructed and accessible from floor level to service personnel. If during in-home service repair cannot be completed, it may be necessary to remove, repair and return the product. If in-home service is unavailable, SAMSUNG may elect, at our option, to provide for transportation of our choice to and from a SAMSUNG authorized service center. Otherwise, transportation to and from the SAMSUNG authorized service center is the responsibility of the purchaser.

SAMSUNG does not warrant uninterrupted or error-free operation of the product, and shall not be liable for the loss or destruction of data or media resulting from the use or service of this product. It is the purchaser's responsibility to secure all programs and data contained in or affected by the product. The purchaser is cautioned that product performance may be affected by installation, system configuration, software, applications, equipment compatibility, purchaser data and operator control of the system, among other factors, and it is the purchaser's responsibility to determine the functional implementation.

SAMSUNG's obligations with respect to software products distributed by SAMSUNG under the SAMSUNG brand name are set forth in the applicable end user license agreement. Non-SAMSUNG hardware and software products, if provided, are on an "AS IS" basis. Non-SAMSUNG manufacturers, suppliers, publishers, and service providers may provide their own warranties.

This limited warranty covers manufacturing defects in materials and workmanship encountered in normal, noncommercial use of this product, and shall not apply to the following, including, but not limited to: damage which occurs in shipment; delivery and installation; applications and uses for which this product was not intended; altered product or serial numbers; cosmetic damage or exterior finish; accidents, abuse, neglect, fire, water, lightning or other acts of nature; use of products, equipment, systems, utilities, services, parts, supplies, accessories, applications, installations, repairs, external plumbing and leaks, external wiring, circuit breakers, fuses or connectors not supplied and authorized by SAMSUNG, or which damage this product or result in service problems; incorrect electrical line voltage, fluctuations and surges; customer adjustments and failure to follow operating instructions, cleaning, maintenance and environmental instructions that are covered and prescribed in the instruction book; reception or display problems and distortion related to noise, echo, interference or other signal transmission and delivery problems; reduced screen brightness related to normal tube and lamp aging, or burned-in images; loss of food due to spoilage; consumable items including filters and light bulbs.

THERE ARE NO EXPRESS WARRANTIES OTHER THAN THOSE LISTED AND DESCRIBED ABOVE, AND NO WARRANTIES WHETHER EXPRESS OR IMPLIED, INCLUDING, BUT NOT LIMITED TO, ANY IMPLIED WARRANTIES OF MERCHANTABILITY OR FITNESS FOR A PARTICULAR PURPOSE, SHALL APPLY AFTER THE EXPRESS WARRANTY PERIODS STATED ABOVE, AND NO OTHER EXPRESS WARRANTY OR GUARANTY GIVEN BY ANY PERSON, FIRM OR CORPORATION WITH RESPECT TO THIS PRODUCT SHALL BE BINDING ON SAMSUNG. SAMSUNG SHALL NOT BE LIABLE FOR LOSS OF REVENUE OR PROFITS, FAILURE TO REALIZE SAVINGS OR OTHER BENEFITS, OR ANY OTHER SPECIAL, INCIDENTAL OR CONSEQUENTIAL DAMAGES CAUSED BY THE USE, MISUSE OR INABILITY TO USE THIS PRODUCT, REGARDLESS OF THE LEGAL THEORY ON WHICH THE CLAIM IS BASED, AND EVEN IF SAMSUNG HAS BEEN ADVISED OF THE POSSIBILITY OF SUCH DAMAGES. NOR SHALL RECOVERY OF ANY KIND AGAINST SAMSUNG BE GREATER IN AMOUNT THAN THE PURCHASE PRICE OF THE PRODUCT SOLD BY SAMSUNG AND CAUSING THE ALLEGED DAMAGE. WITHOUT LIMITING THE FOREGOING, PURCHASER ASSUMES ALL RISK AND LIABILITY FOR LOSS, DAMAGE OR INJURY TO PURCHASER AND PURCHASER'S PROPERTY AND TO OTHERS AND THEIR PROPERTY ARISING OUT OF THE USE, MISUSE OR INABILITY TO USE THIS PRODUCT SOLD BY SAMSUNG NOT CAUSED DIRECTLY BY THE NEGLIGENCE OF SAMSUNG. THIS LIMITED WARRANTY SHALL NOT EXTEND TO ANYONE OTHER THAN THE ORIGINAL PURCHASER OF THIS PRODUCT, IS NONTRANSFERABLE AND STATES YOUR EXCLUSIVE REMEDY.

Some states do not allow limitations on how long an implied warranty lasts, or the exclusion or limitation of incidental or consequential damages, so the above limitations or exclusions may not apply to you. This warranty gives you specific legal rights, and you may also have other rights, which vary from state to state.

To obtain warranty service, please contact SAMSUNG at:

SAMSUNG CUSTOMER CARE CENTER
Samsung Electronics America, Inc. 105 Challenger Road Ridgefield Park NJ 07660-0511
1-800-SAMSUNG (1-800-726-7864) and www.SAMSUNG.com

061002

MEMO

If you have any questions or comments relating to Samsung products,
please contact the SAMSUNG customer care center.
Samsung Electronics America, Inc.
105 Challenger Road Ridgefield Park, NJ 07660-0511
1-800-SAMSUNG(1-800-726-7864)
www.samsung.com



All right reserved. This manual maynot be reproduced in whole or in part in any form without written permission from the SAMSUNG ELECTRONICS Company