

Instructions for converting range to operate on Liquefied Petroleum Gas



INSTALLATION AND SERVICE MUST BE PERFORMED BY
A QUALIFIED INSTALLER.
IMPORTANT: SAVE FOR LOCAL ELECTRICAL INSPECTOR'S USE.
READ AND SAVE THESE INSTRUCTIONS FOR FUTURE REFERENCE.



⚠ WARNING This conversion kit must be installed by a qualified service technician in accordance with the manufacturer's instructions and all applicable codes and requirements of the authority having jurisdiction. Failure to follow instructions may result in fire, explosion or production of carbon monoxide causing property damage, personal injury or loss of life. The qualified service agency is responsible for the proper installation of this kit. The installation is not proper and complete until the operation of the converted appliance is checked as specified in the manufacturer's instructions supplied with this kit.

⚠ CAUTION Before proceeding with the conversion, shut off the gas supply before disconnecting electrical power to the range. Be sure both power supplies are off before installing the conversion kit. Failure to do so could cause serious bodily injury.

Determine the combination of top burners that are featured on your range. Identify the parts you need from this kit to complete the L.P. conversion. When burners are converted from Natural to L.P. the BTU ratings are as follows:

5,000 BTU* Natural Gas to 4,500 BTU* L.P. Gas
 9,500 BTU* Natural Gas to 8,000 BTU* L.P. Gas
 12,000 BTU* Natural Gas to 10,000 BTU* L.P. Gas
 14,000 BTU* Natural Gas to 11,000 BTU* L.P. Gas
 16,000 BTU* Natural Gas to 14,000 BTU* L.P. Gas

Quantity	Part Number	Part Description	Notes
1	316037527	L.P. Conversion Kit Label	English & French
1	316417504	Instructions for converting range to L.P. Gas	English, French & Spanish
1	316005215	Rating Plate - English	4 - 8k
1	316005216	Rating Plate - English	3 + 1
1	316005217	Rating Plate - English	2 + 1 + 1
1	316005218	Rating Plate - English	1 + 1 + 1 + 1
1	316005219	Rating Plate - French	4 - 8k
1	316005220	Rating Plate - French	3 + 1
1	316005221	Rating Plate - French	2 + 1 + 1
1	316005222	Rating Plate - French	1 + 1 + 1 + 1
1	316241200	L.P. Conversion Label	English, French & Spanish
1	316237910	Orifice - 14,000 BTU*	Black
1	316237904	Orifice - 11,000 BTU*	Red
1	316237905	Orifice - 10,000 BTU*	Green
4	316237906	Orifice - 8,000 BTU*	No Color
1	316237907	Orifice - 4,500 BTU*	Blue
1	316005223	Rating Plate - English	1-11k, 2-8k, 1-4.5k
1	316005224	Rating Plate - French	1-11k, 2-8k, 1-4.5k
1	316005225	Rating Plate - English	1-11k + 3-8k
1	316005226	Rating Plate - French	1-11k + 3-8k
1	316005227	Rating Plate - English	1-14k, 1-10-k, 1-8k, 1-4.5k
1	316005228	Rating Plate - French	1-14k, 1-10-k, 1-8k, 1-4.5k
1	316005229	Rating Plate - English	1-14k, 1-10-k, 1-8k, 1-4.5k
1	316005230	Rating Plate - French	1-14k, 1-10-k, 1-8k, 1-4.5k

*Note: For operation at elevations above 2000 ft., appliance rating shall be reduced at the rate of 4 percent for each 1000 ft. above sea level.

IMPORTANT: After replacing the natural gas to LP orifices, be sure to keep the original factory installed natural gas orifices for future range conversion back to natural gas. The factory orifices are marked with 101 for 5,000 BTU; 154 for 9,500 BTU; 175 for 12,000 BTU; 193 for 14,000 BTU and 199 for 16,000 BTU.

Tools Required for L.P. Conversion:

3/8", 1/2" and 5/8" Open End Wrench 

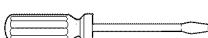
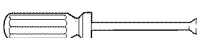
1/8" Wide Flat Blade Screwdriver  & 7mm Nutdriver 

Instructions for converting range to operate on Liquefied Petroleum Gas

How to Convert the Range for use with LP/Propane Gas

1. Convert the Pressure Regulator

To access the gas regulator, remove the storage drawer or warmer drawer. If equipped with a storage drawer, open and remove the drawer completely. For models equipped with a storage drawer or front panel, remove the storage or front panel and skip steps a & b below. For models equipped with warmer drawer, follow all the instructions below to remove the warmer drawer.

- ⚠ WARNING** Electrical Shock Hazard can occur and result in serious injury or death. Disconnect electrical power to the range before removing the warmer drawer for servicing.
- Locate glide lever on each side of drawer, pull up on the left glide lever and push down on the right glide lever (See Fig. 1).
- Pull the drawer away from the range (See Fig. 2).
- Remove the regulator access cover if equipped. **Do not remove the Pressure Regulator or allow it to turn.**
- Remove the dust protector from the cap. Using a 5/8" wrench, unscrew the cap from the pressure regulator. **Do not remove the spring from the regulator.**
- Turn the cap over so the hollow end faces outward. Place the solid end of the cap into the loop end of the dust protector (See Fig. 3).
- Replace the cap on the regulator. The letters LP should be visible on the exposed end of the cap. Snap the dust protector over the regulator cap.

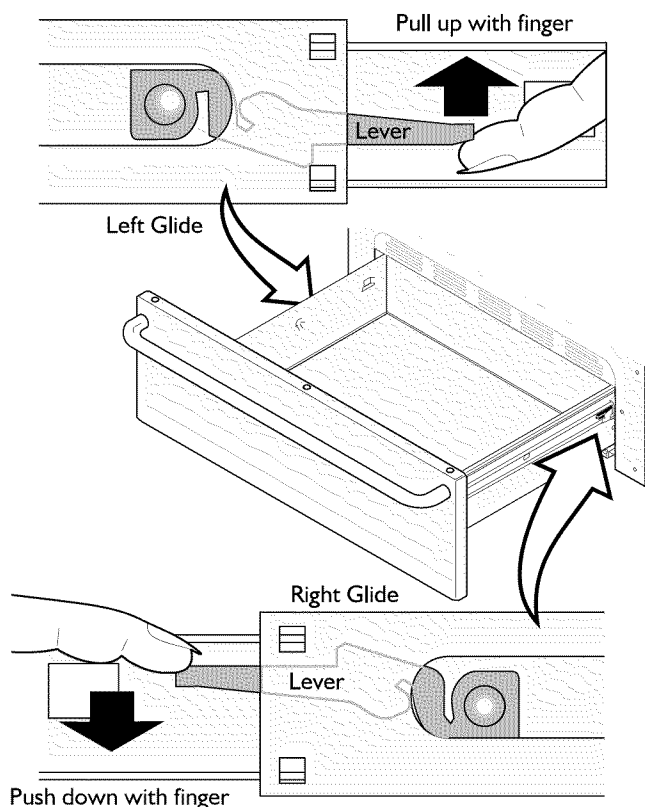

Fig. 1

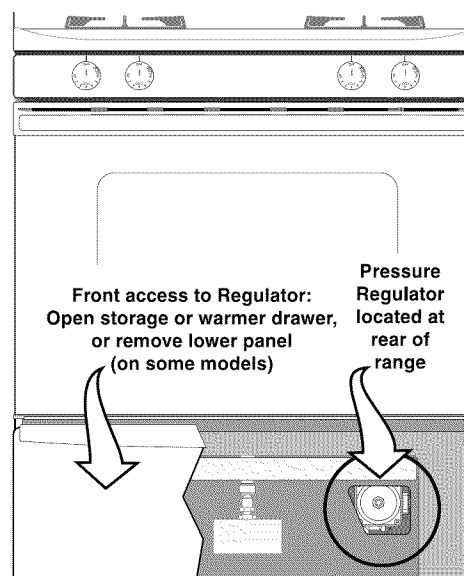

Fig. 2

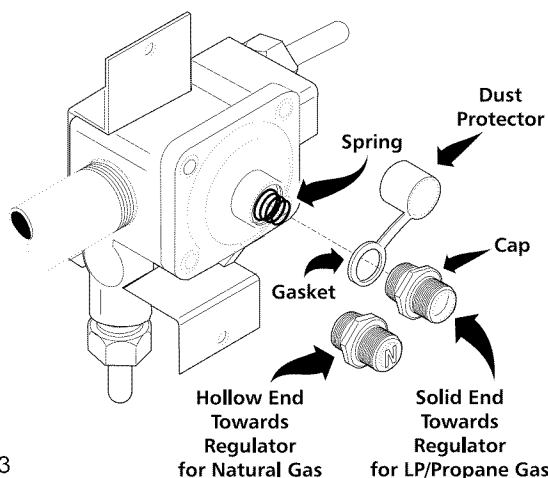

Fig. 3

Natural Gas Orifice to L.P. Orifice Conversion for each size of burner

(A locations) 5,000 BTU Natural Gas converts to 4,500 BTU L.P. Gas
Install (blue) marked orifice .68mm for L.P.

(B locations) 9,500 BTU Natural Gas converts to 8,000 BTU L.P. Gas
Install (no color) marked orifice .89 mm for L.P.

(D locations) 12,000 BTU Natural Gas converts to 10,000 BTU L.P. Gas
Install (green) marked orifice .95 mm for L.P.

(E locations) 14,000 BTU Natural Gas converts to 11,000 BTU L.P. Gas
Install (red) marked orifice 1.01 mm for L.P.

(F locations) 16,000 BTU Natural Gas converts to 14,000 BTU L.P. Gas
Install (black) marked orifice 1.99mm for L.P.

Fig. 4

Instructions for converting range to operate on Liquefied Petroleum Gas

WARNING

Use caution when replacing each burner cap so the electrode is not damaged.

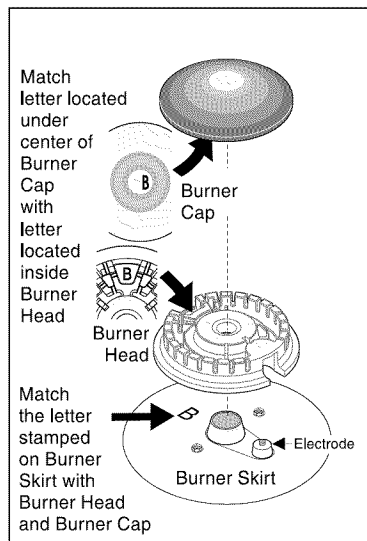

B = 9.5k
D = 12k
E = 14 or 14.2k

A = 5k
B = 9.5k

B = 9.5k
(some models)

B = 9.5k

B = 9.5k
D = 12k
E = 14 or 14.2k
F = 16 or 16.2

Fig. 5

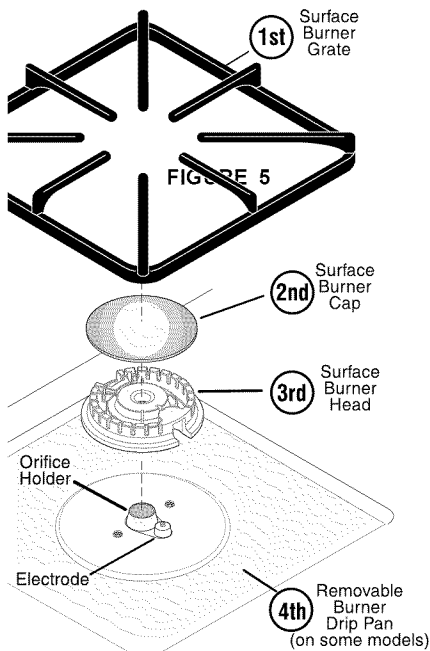

Fig. 6

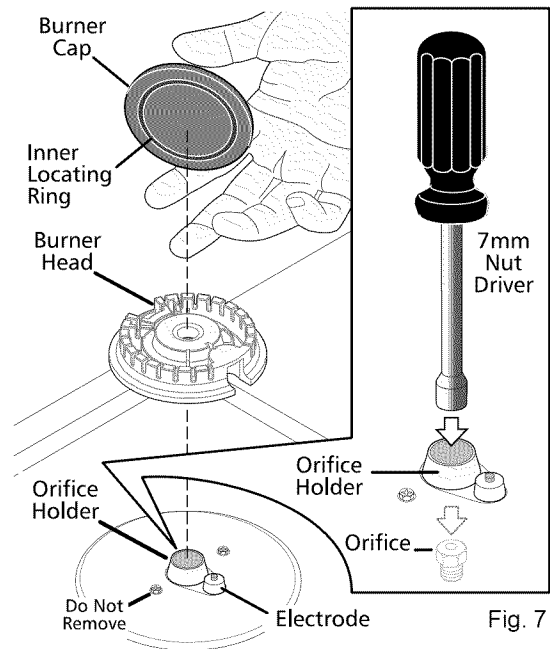

Fig. 7

2. Convert Surface Burners for use with LP/Propane Gas

CAUTION Unlike the standard gas range, THIS COOKTOP IS NOT REMOVABLE. Do not attempt to remove this cooktop. Save the natural gas orifices removed from the appliance for possible future conversions to natural gas.

For all burner locations:

- Remove the top grates and burner caps (See Fig. 6).
- Lift off the burner heads.
- Remove the 4 factory installed natural gas orifices from the center of the orifice holders using a 7 mm nutdriver (See Fig. 7). Remember to keep the original Natural Gas Orifices for later conversion to Natural Gas. Refer to page 1 under "IMPORTANT" to identify their markings.
- Replace the orifice in each of the four orifice holders with the correct LP/Propane gas orifice (See the LP Kit chart on page 1; also refer to Figs. 4 & 5 for the correct LP orifice installation at each of the four surface burner locations). Tighten each orifice until snug. Use caution not to overtighten.
- Replace the 4 burner heads. Match letter located under center of Burner Caps with letter located inside Burner Heads. Match the letter stamped on Burner Skirt with Burner Head and Burner Cap. (Refer to Fig. 5). Be sure burner heads mate correctly with each surface igniter, then replace the burner caps and burner grates.

3. Convert Oven Burner Orifice for LP/Propane Gas (16,000 BTU*)

- Locate the oven burner spud (See Fig. 8).
- Using a 1/2" wrench, turn down the adjustable spud, which injects gas into the oven burner, until snug against the LP/Propane metering pin (approximately 2-1/2 turns). Do not over tighten.

4. Convert Waist-High Broiler Burner Orifice Flame for LP/Propane Gas (13,500 BTU*) — (for Self-Cleaning Models Only)

- Open the oven door.
- Locate the broiler burner spud and turn down until snug against the LP/Propane metering pin (approximately 1 to 1-1/2 turns). Do not over tighten (See Fig. 8).

5. Reconnect Gas and Electrical Supply to Range.

Leak testing of the appliance shall be conducted according to the Installation Instructions provided with the Range.

Instructions for converting range to operate on Liquefied Petroleum Gas

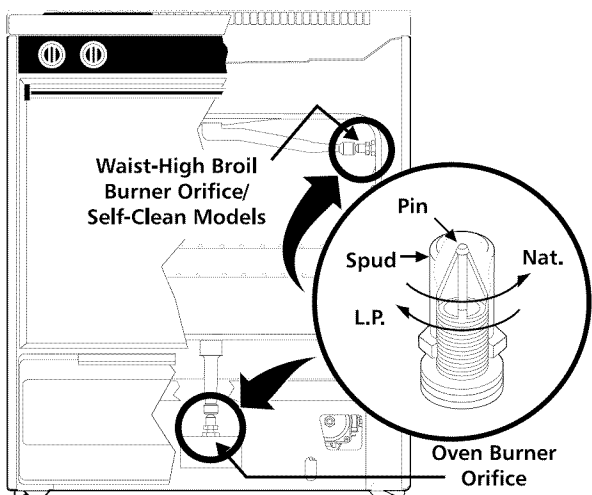

Fig. 8

Checking Manifold Gas Pressure

If it should be necessary to check the manifold gas pressure, remove the burner cap and connect a manometer (water gauge) or other pressure device to the top right front burner orifice. Using a rubber hose with inside diameter of approximately 1/4," hold tubing down tight over orifice. Turn burner valve on. For an accurate pressure check, have at least two (2) other surface burners burning. Be sure the gas supply (inlet) pressure is at least one inch above specified range manifold pressure. The gas supply pressure should never be over 14" water column. When properly adjusted the manifold water column pressure is 10" for LP/Propane gas or 4" for Natural gas.

CAUTION Do not use a flame to check for gas leaks.

- Disconnect the range and its individual shut-off valve from the gas supply piping system during any pressure testing of that system at test pressures greater than 14" of water column pressure (approximately 1/2" psig).
- The appliance must be isolated from the gas supply piping system by closing its individual manual shut-off valve during any pressure testing of the gas supply piping system at test pressures equal to or less than 14" of water column pressure (approximately 1/2" psig).

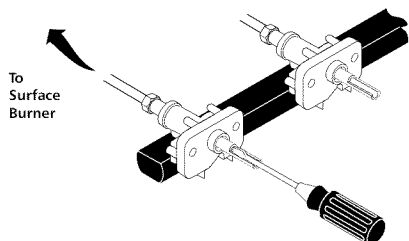

Fig. 9

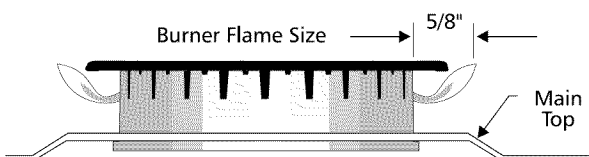

Fig. 10

Test to verify if "LOW" setting should be adjusted:

- Push in and turn control to LITE until burner ignites.
- Push in and quickly turn knob to LOWEST POSITION.
- If burner goes out, reset control to OFF.
- Remove the surface burner control knob.
- Insert a thin-bladed screwdriver into the hollow valve stem and engage the slotted screw inside. Flame size can be increased or decreased with the turn of the screw. Turn counterclockwise to increase flame size. Turn clockwise to decrease flame size. (See Figs. 9 & 10).

Adjust flame until you can quickly turn knob from LITE to LOWEST POSITION without extinguishing the flame. Flame should be as small as possible without going out.

7. Air Shutter-Oven Burner

The air shutter for the oven burner may need adjustment, especially if the unit has been converted for use with LP/Propane gas. The approximate flame length of the oven burner is 1 inch (distinct inner, blue flame) (See Fig. 11).

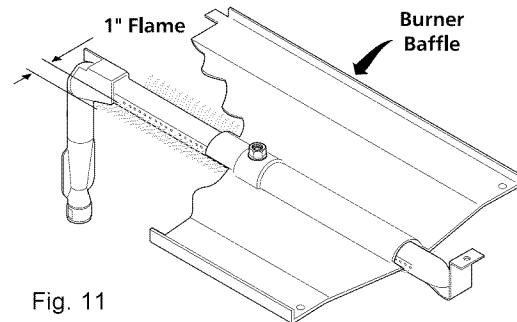

Fig. 11

To determine if the oven burner flame is proper:

- To access the air shutter you must remove the Warmer Drawer (see removal instructions on page 2).
- Remove the oven bottom by removing the screws at rear of oven bottom. Lift up the rear of oven bottom and slide toward back of range to disengage from front of oven front frame.
- Remove burner baffle by removing nut located on top of baffle and two screws from front edge of oven front frame. Lift baffle straight up and out of the oven.
- Set the oven to bake at 350°F and observe the flame. If the flame is yellow in color, increase air shutter opening size. If the flame is a distinct blue color, but lifting away from the burner; reduce the air shutter opening size.
- Turn off oven and allow to cool before adjusting air shutter. To adjust loosen lock-screw (3), reposition air shutter (2), and tighten lock-screw (3) (See Fig. 12).

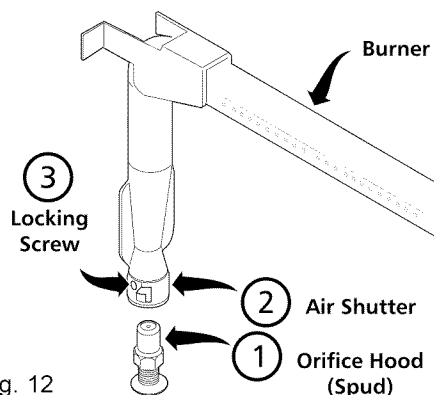

Fig. 12

Retest the burner by repeating step "d" above. When the burner flame is a distinct blue color burning steady, the air shutter is adjusted correctly.

- Replace burner baffle and oven bottom.

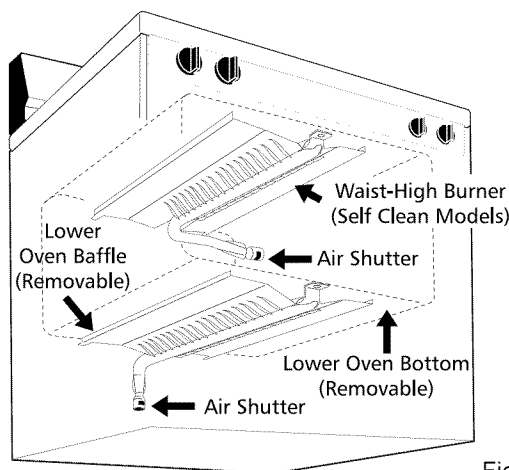

Fig. 13

Instructions for converting range to operate on Liquefied Petroleum Gas

8. Air Shutter-Broil Burner

- Observe the flame to determine if the broiler burner flame is properly adjusted. It should be steady with approximately 1" blue cones and no yellow or orange flame tips (See Fig. 13).
- If adjustment to the air shutter is necessary, locate the broiler burner air shutter (See Fig. 14), loosen shutter lock screw, and adjust to obtain optimum flame. This will normally be completely open for LP/Propane gas. If the flame is yellow in color, increase the air shutter opening size. If the flame is a distinct blue, but lifting away from the burner, reduce the air shutter opening size. Tighten the shutter set screw.

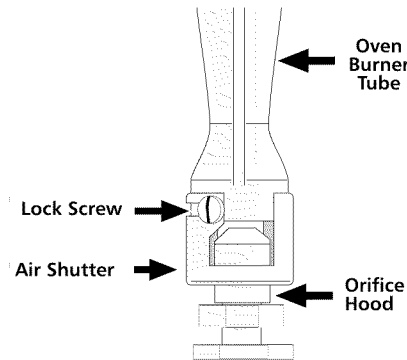

Fig. 14

9. Replace Storage Drawer or Warmer Drawer (instructions for warmer drawer if equipped):

- Pull the bearing glides to the front of the chassis glide (See Fig. 15).
- Align the glide on each side of the drawer with the glide slots on the range.
- Push the drawer into the range until levers "click" (approximately 2"). Pull the drawer open again to seat bearing glides into position. **If you do not hear the levers "click" or the bearing glides do not feel seated remove the drawer and repeat steps "a" through "c".** This will minimize possible damage to the bearing glides.

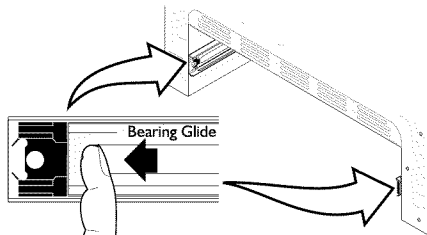

Fig. 15

10. Installation of New LP/Propane Rating/Serial Plate

Record the model and serial number on the LP/Propane Rating/Serial plate provided in this kit. The information can be obtained from the existing Rating/Serial plate. Place new plate as close as possible to the existing Rating/Serial plate on range (See the recommended locations shown in Fig. 16).

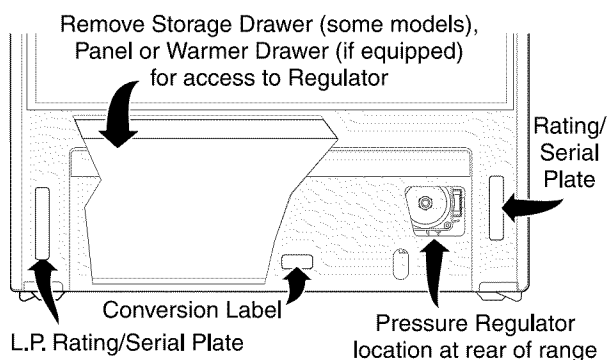

Fig. 16

CONVERSION TO NATURAL GAS

If it becomes necessary to convert the range back to natural gas:

- Disconnect gas and electrical supply from range.
- Convert pressure regulator (See step 1), turn cap over so the solid end of cap faces outward. Place the hollow end of the cap into the loop end of the dust protector.
- Remove the four LP orifices using 7mm nutdriver and replace with the four original factory installed natural gas orifices at their original locations (See figure 4 for locations).
- Convert Oven Burner Orifice for Natural Gas by loosening spud counter-clockwise (approximately 2-1/2 turns; See step 3).
- Convert Waist-High Broiler Burner Orifice (Self-Cleaning Models Only) for Natural Gas by loosening spud counter-clockwise (approximately 1 to 1-1/2 turns; See step 4.)
- Readjust "LOW" Setting for Surface Burner Valves following instructions. (See step 6.)
- Readjust Oven & Broil Burner Air Shutters. (See steps 7 & 8.)