

Operator's Manual

CRAFTSMAN®

C3 1/2" BRUSHLESS DRILL/DRIVER

Model No. 320.38595

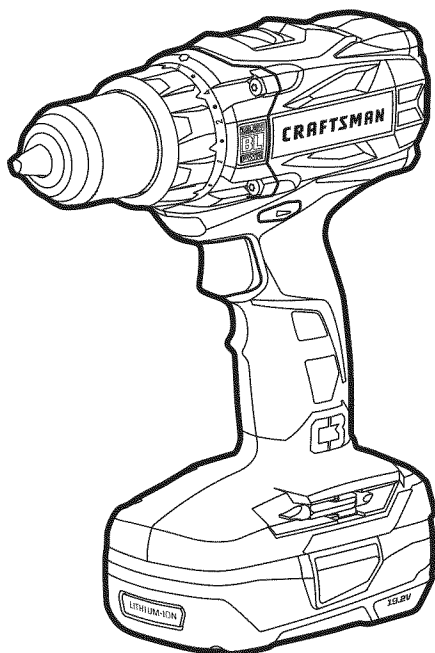

▲ WARNING: To reduce the risk of injury, the user must read and understand the Operator's Manual before using this product.

- WARRANTY
- SAFETY
- DESCRIPTION
- ASSEMBLY
- OPERATION
- MAINTENANCE

Sears Brands Management Corporation, Hoffman Estates,
IL 60179 U.S.A.

www.craftsman.com

TABLE OF CONTENTS

Warranty	Page 2
Safety Symbols	Pages 4-5
Safety Instructions	Pages 6-9
Description	Pages 10-11
Assembly	Page 12
Operation	Pages 13-20
Maintenance	Pages 21-22
Troubleshooting	Page 23
Parts List	Pages 24-25

CRAFTSMAN ONE YEAR LIMITED WARRANTY

FOR ONE YEAR from the date of purchase, this product is warranted against any defects in material or workmanship. With proof of purchase, defective product will be replaced free of charge.

For warranty coverage details to obtain free replacement, visit the web page: www.craftsman.com/warranty

This warranty does not cover the bit, which is an expendable part that can wear out from normal use within the warranty period.

This ONE YEAR warranty is void if this product is ever used while providing commercial services or if rented to another person. For 90 DAY commercial and rental use terms, see the Craftsman warranty web page.

This warranty gives you specific legal rights, and you may also have other rights which vary from state to state.

Sears Brands Management Corporation, Hoffman Estates, IL 60179.

SAVE THESE INSTRUCTIONS!

READ ALL INSTRUCTIONS!

This drill/driver has many features for making its use more pleasant and enjoyable. Safety, performance, and dependability have been given top priority in the design of this product making it easy to maintain and operate.

⚠ DANGER: People with electronic devices, such as pacemakers, should consult their physician(s) before using this product. Operation of electrical equipment in close proximity to a heart pacemaker could cause interference or failure of the pacemaker.

⚠ WARNING: Some dust created by power sanding, sawing, grinding, drilling and other construction activities contains chemicals known to the state of California to cause cancer, birth defects or other reproductive harm. Some examples of these chemicals are:

- Lead from lead-based paints
- Crystalline silica from bricks and cement and other masonry products, and
- Arsenic and chromium from chemically-treated lumber.

Your risk from these exposures varies, depending on how often you do this type of work. To reduce your exposure to these chemical: work in a well ventilated area, and work with approved safety equipment, such as those dust masks that are specially designed to filter out microscopic particles.

SAFETY SYMBOLS

The purpose of safety symbols is to attract your attention to possible dangers. The safety symbols and the explanations with them deserve your careful attention and understanding. The symbol warnings do not, by themselves, eliminate any danger. The instructions and warnings they give are no substitutes for proper accident prevention measures.

⚠ WARNING: Be sure to read and understand all safety instructions in this manual, including all safety alert symbols such as “**DANGER**,” “**WARNING**,” and “**CAUTION**” before using this tool. Failure to follow all instructions listed in this manual may result in electric shock, fire and/or serious personal injury.

SYMBOL SIGNAL MEANING

SAFETY ALERT SYMBOL: Indicates **DANGER**, **WARNING**, or **CAUTION**; may be used in conjunction with other symbols or pictographs.

⚠ DANGER: Indicates a hazardous situation which, if not avoided, will result in death or serious injury.

⚠ WARNING: Indicates a hazardous situation which, if not avoided, could result in death or serious injury.

⚠ CAUTION: Indicates a hazardous situation which, if not avoided, could result in minor or moderate injury.

Damage prevention and Information Messages

These inform the user of important information and/or instructions that could lead to equipment or other property damage if they are not followed. Each message is preceded by the word “NOTICE”, as in the example below:

NOTICE: Equipment and/or property damage may result if these instructions are not followed.



⚠ WARNING: To ensure safety and reliability, all repairs should be performed by a qualified service technician.



⚠ WARNING: The operation of any power tools can result in foreign objects being thrown into your eyes, which can result in severe eye damage. Before beginning power tool operation, always wear safety goggles or safety glasses with side shield and a full face shield when needed. We recommend a Wide Vision Safety Mask for use over eyeglasses or standard safety glasses with side shields. Always use eye protection which is marked to comply with ANSI Z87.1.

SAVE THESE INSTRUCTIONS

Some of these following symbols may be used on this tool. Please study them and learn their meaning. Proper interpretation of these symbols will allow you to operate the tool better and more safely.

SYMBOL	NAME	DESIGNATION/EXPLANATION
V	Volts	Voltage
A	Amperes	Current
Hz	Hertz	Frequency (cycles per second)
W	Watt	Power
min	Minutes	Time
	Alternating Current	Type of current
	Direct Current	Type or a characteristic of current
n_0	No Load Speed	Rotational speed, at no load
	Class II Construction	Double-insulated construction
.../min	Per Minute	Revolutions, strokes, surface speed, orbits, etc., per minute
	Wet Conditions Alert	Do not expose to rain or use in damp locations.
	Read The Operator's Manual	To reduce the risk of injury, user must read and understand operator's manual before using this product.
	Eye Protection	Always wear safety goggles or safety glasses with side shields and a full face shield when operating this product.
	Safety Alert	Precautions that involve your safety.
	No-Hands Symbol	Failure to keep your hands away from the blade will result in serious personal injury.
	No-Hands Symbol	Failure to keep your hands away from the blade will result in serious personal injury.
	No-Hands Symbol	Failure to keep your hands away from the blade will result in serious personal injury.
	No-Hands Symbol	Failure to keep your hands away from the blade will result in serious personal injury.
	Hot Surface	To reduce the risk of injury or damage, avoid contact with any hot surface.

SAFETY INSTRUCTIONS

GENERAL POWER TOOL SAFETY WARNINGS

▲ WARNING: Read all safety warnings and instructions. Failure to follow the warnings and instructions may result in electric shock, fire and/or serious injury.

Save all warnings and instructions for future reference.

The term “power tool” in the warnings refers to your mains-operated (corded) power tool or battery-operated (cordless) power tool.

WORK AREA SAFETY

- **Keep work area clean and well lit.** Cluttered or dark areas invite accidents.
- **Do not operate power tools in explosive atmospheres, such as in the presence of flammable liquids, gases or dust.** Power tools create sparks which may ignite the dust or fumes.
- **Keep children and bystanders away while operating a power tool.** Distractions can cause you to lose control.

ELECTRICAL SAFETY

- **Power tool plugs must match the outlet. Never modify the plug in any way. Do not use any adaptor plugs with earthed (grounded) power tools.** Unmodified plugs and matching outlets will reduce risk of electric shock.
- **Avoid body contact with earthed or grounded surfaces such as pipes, radiators, ranges and refrigerators.** There is an increased risk of electric shock if your body is earthed or grounded.
- **Do not expose power tools to rain or wet conditions.** Water entering a power tool will increase the risk of electric shock.
- **Do not abuse the cord. Never use the cord for carrying, pulling or unplugging the power tool. Keep cord away from heat, oil, sharp edges or moving parts.** Damaged or entangled cords increase the risk of electric shock.
- **When operating a power tool outdoors, use an extension cord suitable for outdoor use.** Use of a cord suitable for outdoor use reduces the risk of electric shock.
- **If operating a power tool in a damp location is unavoidable, use a ground fault circuit interrupter (GFCI) protected supply.** Use of a GFCI reduces the risk of electric shock.

PERSONAL SAFETY

- **Stay alert, watch what you are doing and use common sense when operating a power tool. Do not use tool while tired or under the influence of drugs, alcohol, or medication.** A moment of inattention while operating power tools may result in serious personal injury.
- **Use personal protective equipment. Always wear eye protection.** Protective equipment such as dust mask, non-skid safety shoes, hard hat, or hearing protection used for appropriate conditions will reduce personal injuries.
- **Prevent unintentional starting. Ensure the switch is in the off-position before connecting to power source and/or battery pack, picking up or carrying the tool.** Carrying power tools with your finger on the switch or energizing in power tools that have the switch on invites accidents.
- **Remove any adjusting key or wrench before turning the power tool on.** A wrench or a key left attached to a rotating part of the power tool may result in personal injury.
- **Do not overreach. Keep proper footing and balance at all times.** This enables better control of the power tool in unexpected situations.
- **Dress properly. Do not wear loose clothing or jewelry. Keep your hair, clothing and gloves away from moving parts.** Loose clothes, jewelry or long hair can be caught in moving parts.
- **If devices are provided for the connection of dust extraction and collection facilities, ensure these are connected and properly used.** Use of these devices can reduce dust-related hazards.

POWER TOOL USE AND CARE

- **Do not force the power tool. Use the correct power tool for your application.** The correct power tool will do the job better and safer at the rate for which it was designed.
- **Do not use the power tool if the switch does not turn it on and off.** Any power tool that cannot be controlled with the switch is dangerous and must be repaired.
- **Disconnect the plug from the power source and/or the battery pack from the power tool before making any adjustments, changing accessories, or storing power tools.** Such preventive safety measures reduce the risk of starting the power tool accidentally.
- **Store idle power tools out of the reach of children and do not allow persons unfamiliar with the power tool or these instructions to operate the power tool.** Power tools are dangerous in the hands of untrained users.

- **Maintain power tools. Check for misalignment or binding of moving parts, breakage of parts and any other condition that may affect the power tool's operation. If damaged, have the power tool repaired before use.** Many accidents are caused by poorly maintained power tools.
- **Keep cutting tools sharp and clean.** Properly maintained cutting tools with sharp cutting edges are less likely to bind and are easier to control.
- **Use the power tool, accessories and tool bits etc., in accordance with these instructions, taking into account the working conditions and the work to be performed.** Use of the power tool for operations different from those intended could result in a hazardous situation.

BATTERY TOOL USE AND CARE

- **Recharge only with the charger specified by the manufacturer.** A charger that is suitable for one type of battery pack may create a risk of fire when used with another battery pack.
- **Use power tools only with specifically designated battery packs.** Use of any other battery packs may create a risk of injury and fire.
- **When battery pack is not in use, keep it away from other metal objects, like paper clips, coins, keys, nails, screws or other small metal objects that can make a connection from one terminal to another.** Shorting the battery terminals together may cause burns or a fire.
- **Under abusive conditions, liquid may be ejected from the battery; avoid contact. If contact accidentally occurs, flush with water. If liquid contacts eyes, additionally seek medical help.** Liquid ejected from the battery may cause irritation or burns.

SERVICE

- **Have your power tool serviced by a qualified repair person using only identical replacement parts.** This will ensure that the safety of the power tool is maintained.
- **Follow instructions in the Maintenance section of this manual.** Use of unauthorized parts or failure to follow Maintenance instructions may create a risk of shock or injury.

SPECIFIC SAFETY RULES FOR BRUSHLESS DRILL/DRIVER

- **Know your drill/driver.** Read operator's manual carefully. Learn the applications and limitations, as well as the specific potential hazards related to this tool. Following this rule will reduce the risk of electric shock, fire or serious injury.
- **Hold power tool by insulated gripping surfaces, when performing an operation where the cutting accessory may contact hidden wiring.** Cutting accessory contacting a "live" wire may make exposed metal parts of the power tool "live" and could give the operator an electric shock.

- **Use auxiliary handle(s), if supplied with the tool.** Loss of control can cause personal injury.
- **Always wait until the machine has come to a complete stop before placing it down.** The tool insert can jam and lead to loss of control over the power tool.
- **Do not permit children to use the drill/driver; it is not a toy.**
- **Remove the battery pack from the drill/driver before performing any routine maintenance or cleaning.**
- **Do not disassemble the drill/driver.**
- **Do not place the drill/driver or battery pack near fire or heat.** They may explode.
- **Secure the workpiece.** Clamping devices or a vise will hold the workpiece in place better than the hand.
- **Always wait until the machine has come to a complete stop before placing it down.** The tool insert can jam and lead to loss of control over the power tool.
- **Before performing any kind of work on the tool (e. g. maintenance, bit change, etc.) or when transporting and storing it, always set the direction-of-rotation selector to center off position.** Unintentional activation of the on/off switch may result in personal injury.
- **Use protective gloves when removing the bit from the tool, or allow the clamp to cool down.** The bit may be hot after prolonged use.
- **Do not dispose of a worn out battery pack by incinerating.** Do not incinerate the battery, even if it is severely damaged or completely worn out. The battery may explode in fire.
- **Do not operate the drill/driver or the charger near flammable liquids or in a gaseous or explosive environment.** Internal sparks may ignite fumes.
- **To reduce the risk of electric shock, do not put the drill/driver, battery, or charger in water or other liquid.** Do not place or store the product where it can fall or be pulled into a tub or sink.
- **Keep the drill/driver dry, clean and free from oil and grease.** Always use a clean cloth when cleaning. Never use brake fluids, gasoline, petroleum-based products, or any strong solvent to clean the drill/driver.
- **Save these instructions.** Refer to them frequently and use them to instruct others who may use this tool. If you loan someone this tool, also loan them these instructions.

DESCRIPTION

KNOW YOUR BRUSHLESS DRILL/DRIVER (Fig. 1)

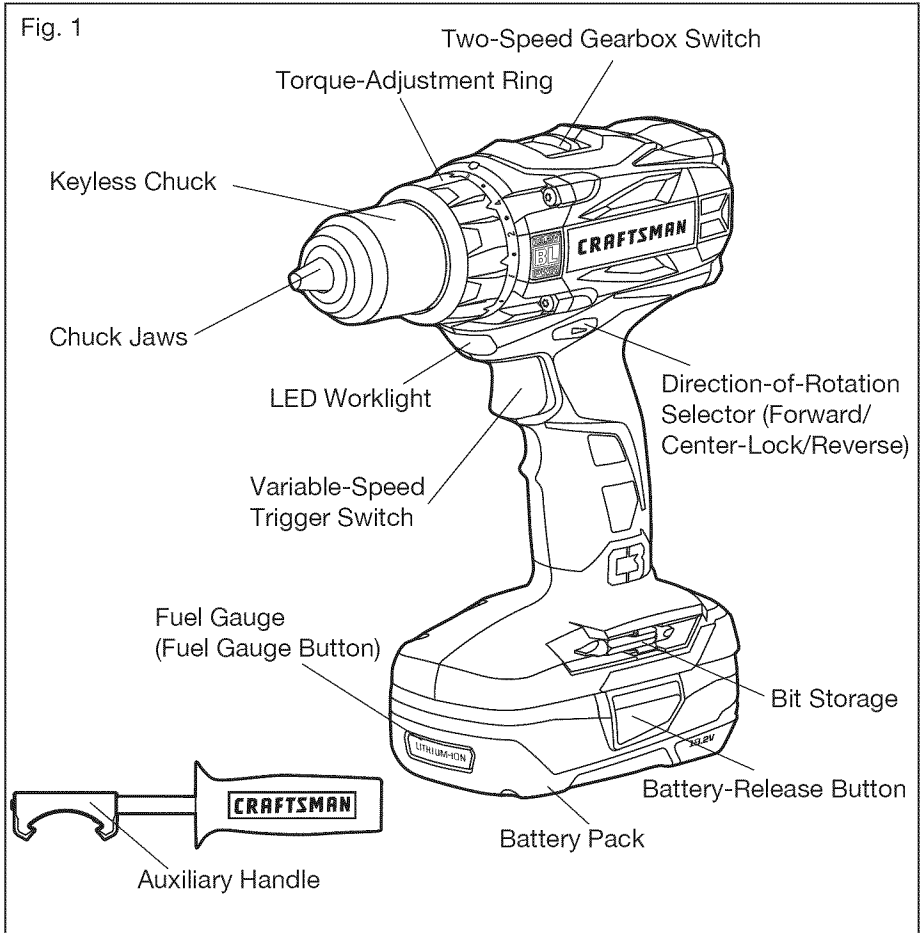

PRODUCT SEPCIFICATIONS	
Motor	19.2 Volt DC
Chuck	1/2 in. (13mm)
No-load Speed	LO 0-470/min/HI 0-1800/min
Clutch	22 Position
Torque	600 in.lbs
Battery Type	Lithium-Ion
Battery Voltage	19.2 Volt DC
Charger Input	120-Volts, 60 Hz AC only
Optimum Charging Temperature	50°F (10° C) -104°F (40°C)

▲ WARNING: The safe use of this product requires an understanding of the information on the tool and in this operator’s manual, as well as knowledge of the project you are attempting. Before use of this product, familiarize yourself with all operating features and safety rules.

ADJUSTABLE TORQUE

The drill/driver has a 22-position clutch: 1 drill position and 21 torque positions.

TWO-SPEED GEARBOX

The two-speed gearbox is designed for drilling or driving at LO or HI speeds. A slide switch is located on top of your drill/driver for selecting the appropriate speed.

VARIABLE SPEED

The variable-speed trigger switch delivers higher speed with increased trigger pressure and lower speed with decreased trigger pressure.

KEYLESS CHUCK

The keyless chuck allows you to hand-tighten or release the drill bit in the chuck jaws.

FORWARD/CENTER-LOCK /REVERSE

The drill/driver has a direction-of-rotation selector located above the trigger switch for changing the direction of bit rotation. Setting the trigger switch in the OFF (center-lock) position helps reduce the possibility of accidental starting when not in use.

LED WORKLIGHT

The LED worklight, located on the front of the drill/driver, illuminates when the trigger switch is depressed. This feature provides extra light for increased visibility.

ASSEMBLY

⚠ WARNING: If any parts are broken or missing, do not attempt to attach the battery pack or operate the drill/driver until the broken or missing parts are replaced. Failure to do so could result in possible serious injury.

⚠ WARNING: Do not attempt to modify this drill/driver or create accessories not recommended for use with this drill/driver. Any such alteration or modification is misuse and could result in a hazardous condition leading to possible serious injury.

⚠ WARNING: To prevent accidental starting that could cause serious personal injury, always remove the battery pack from the drill/driver when changing bits.

UNPACKING

This product has been shipped completely assembled.

- Carefully remove the tool and any accessories from the carton. Make sure that all items listed in the packing list are included.
- Inspect the tool carefully to make sure no breakage or damage occurred during shipping.
- Do not discard the packing material until you have carefully inspected and satisfactorily operated the tool.
- If any parts are damaged or missing, please return the tool to the place of purchase.

PACKING LIST

Brushless drill/driver, auxiliary handle, double-ended bit (installed on the drill/driver), soft bag and operator's manual.

OPERATION

TO ATTACH BATTERY PACK (Fig. 2)

1. Lock the trigger switch on the drill/driver by placing the direction-of-rotation (forward/center-lock/reverse) selector in the center position.
2. Align the raised rib on the battery pack with the groove inside the drill/driver, and then insert the battery pack into the tool.

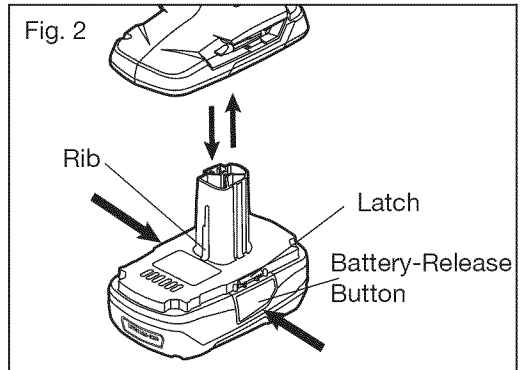

NOTICE: Make sure that the latch on the battery pack snaps into place and the battery pack is secured to the tool before beginning operation. Improper assembly of the battery pack can cause damage to internal components.

TO DETACH BATTERY PACK (Fig. 2)

1. Lock the trigger switch on the drill/driver by placing the direction-of-rotation (forward/center-lock/reverse) selector in the center position.
2. Depress both battery-release buttons, located on the sides of the battery pack, to release the battery pack.
3. Pull the battery pack out and remove it from the tool.

WARNING: Battery tools are always in operating condition. Therefore, the direction-of-rotation selector should always be locked when not in use or carrying the tool at your side.

TRIGGER SWITCH (Fig. 3)

To turn the drill/driver ON, depress the trigger switch.

To turn it OFF, release the trigger switch.

VARIABLE SPEED (Fig. 3)

The variable-speed trigger switch delivers higher speed with increased trigger pressure and lower speed with decreased trigger pressure.

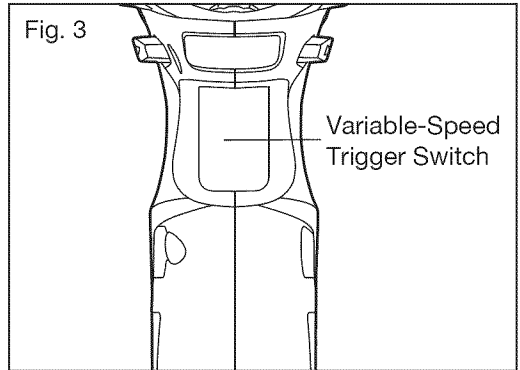

DIRECTION-OF-ROTATION SELECTOR (FORWARD/CENTER-LOCK/REVERSE) (Fig. 4)

The direction of bit rotation is reversible and is controlled by a selector located above the trigger switch.

With the drill/driver held in normal operating position, as shown in Fig. 4:

1. Position the direction-of-rotation selector to the left of the tool for drilling.
2. Position the direction-of-rotation selector to the right of the tool for reverse.
3. Setting the switch in the OFF (center-lock) position helps reduce the possibility of accidental starting when not in use.

NOTICE: To prevent gear damage, always allow the chuck to come to a complete stop before changing the direction of rotation.

NOTICE: The drill/driver will not run unless the direction-of-rotation selector is engaged fully to the left or right.

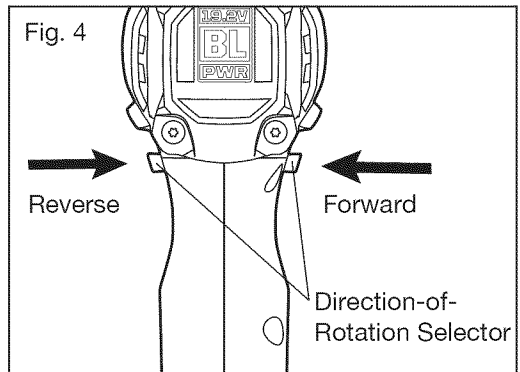

ELECTRIC BRAKE

To stop the drill/driver, release the trigger switch and allow the chuck to come to a complete stop. The electric brake quickly stops the chuck from rotating. This feature engages automatically when you release the trigger switch.

KEYLESS CHUCK (Fig. 5)

The drill/driver has a keyless chuck to tighten or release bits in the chuck jaws. The arrows on the chuck indicate the direction in which to rotate the chuck in order to GRIP (tighten) or OPEN (release) the chuck jaws on the bit.

⚠ WARNING: Do not hold the chuck with one hand and use the power of the drill/driver to tighten the chuck jaws on the drill bit. The chuck could slip in your hand, or your hand could slip and come in contact with the rotating bit. This could cause an accident resulting in serious personal injury.

TWO-SPEED GEARBOX (Fig. 6)

The drill/driver has a two-speed gearbox for drilling or driving at LO or HI speeds. A slide switch is located on the top of the drill/driver to select either LO or HI speed.

Use LO speed for high power and torque applications and HI speed for fast drilling or driving applications.

When using drill/driver in the LO speed range, the speed will decrease and the drill/driver will have more power and torque. Use LO speed for starting holes without a center punch, drilling metals or plastic, drilling ceramics, or in applications requiring a higher torque.

HI speed is better for drilling wood and wood composites and for using abrasive and polishing accessories.

NOTICE: Avoid running the drill/driver at HI speed for extended periods of time. Running at HI speed under constant usage may cause the drill/driver to become overheated. If this occurs, cool the drill/driver by running it without a load at LO speed.

NOTICE: Never change gears while the tool is running. Failure to obey this caution could result in serious damage to the drill/driver.

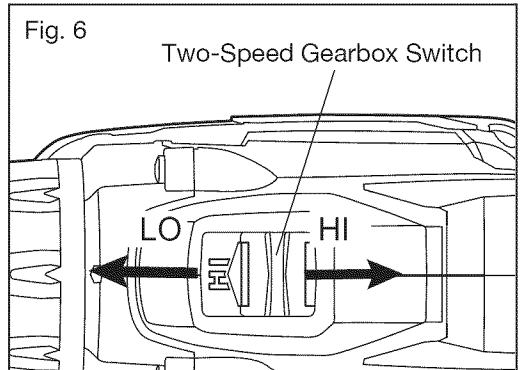
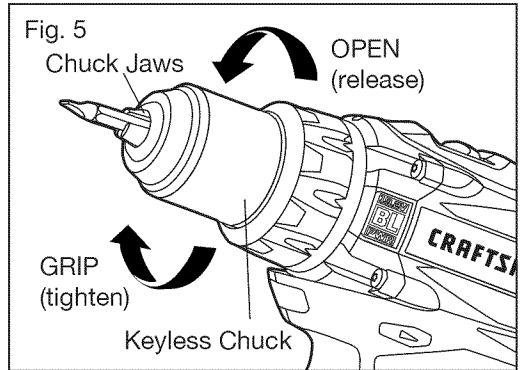

ADJUSTABLE-TORQUE CLUTCH (Fig. 7)

The higher the torque drill setting, the more force the drill/driver produces to turn an object in either LO or HI rotation speed. When using the drill/driver for different driving applications, increase or decrease the torque in order to help prevent damage to screw heads, threads, workpiece, etc.

Adjust the torque by rotating the torque-adjustment ring. The proper setting depends on the job and the type of bit, fastener, and material you will be using. In general, use greater torque for larger screws. If the torque is too high, the screws may be damaged or broken.

For delicate operations, such as removing a partially stripped screw, use a low torque setting. For operations such as drilling into hardwood, use a higher torque setting.

NOTICE: When adjusting the torque clutch make sure that the speed switch is either completely in the LO or HI position.

CAUTION: Do not change the torque setting when the tool is running.

DRILL MODE (Fig. 8)

Select the drill mode for drilling and other heavy-duty applications.

To select drill mode, rotate the torque-adjustment ring until the drill icon aligns with the torque indicator and the ring clicks into position.

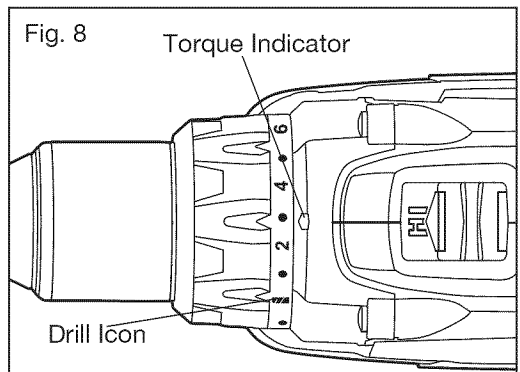
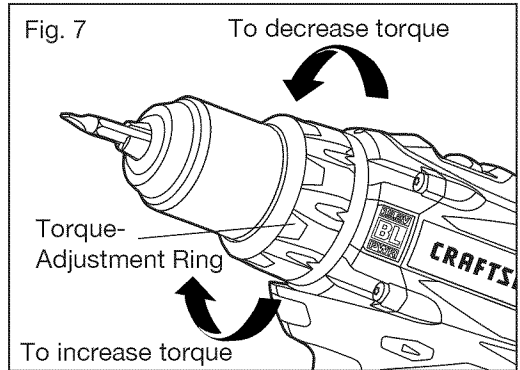

LED WORKLIGHT (Fig. 9)

The LED worklight, located on the base of the drill/driver, will illuminate when the trigger switch is depressed. This provides additional light on the surface of the workpiece. The LED worklight will turn off when the trigger switch is released.

NOTICE: The LED worklight will begin flash slowly if the tool becomes overloaded or if the temperature becomes too high during use.

BIT STORAGE (Fig. 10)

When not in use, the bit provided with the drill/driver can be placed in the storage area located on the base of the drill/driver. Store the bit on the base of the drill/driver by snapping it into place in the bit clip.

FUEL GAUGE (Fig. 11)

This lithium-ion battery pack is equipped with a Fuel Gauge that indicates the battery pack charge level.

To display the amount of charge left in the battery, press the battery Fuel Gauge button; it will illuminate and then it will turn off automatically about 4 seconds later.

- If the charge indicator light glows green, the battery pack is fully charged.
- If it glows orange, it has a usable charge remaining but will soon require recharging.
- If it glows red, the battery requires recharging.

NOTICE: The Fuel Gauge can be used whether the battery is attached or removed from your tool.

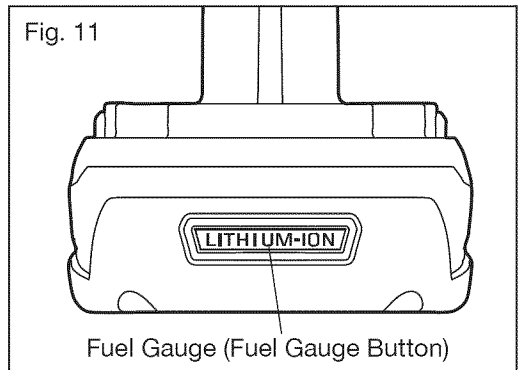
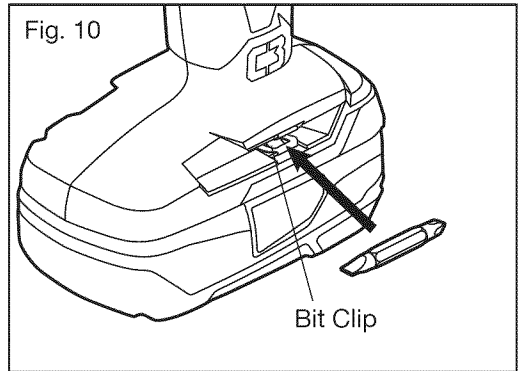
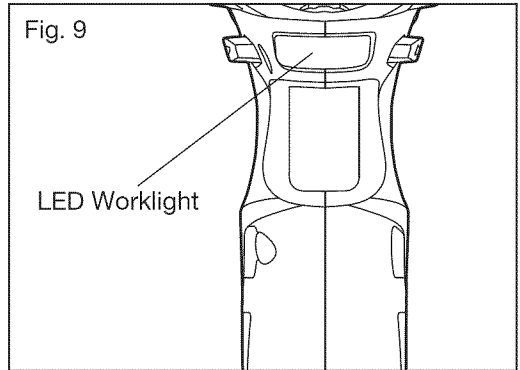

INSTALLING BITS (Fig. 12)

1. Lock the trigger switch by placing the direction-of-rotation selector in the OFF (center-lock) position.
2. Open or close the chuck jaws to a point where the opening is slightly larger than the bit you intend to use.
3. Raise the front of the drill/driver slightly to keep the bit from falling out of the chuck jaws.
4. Insert a bit.
5. Rotate the chuck in the direction of the arrow marked GRIP to close the chuck jaws.

NOTICE: Do not use a wrench to tighten or loosen the chuck jaws.

6. Tighten the chuck jaws securely on the bit.

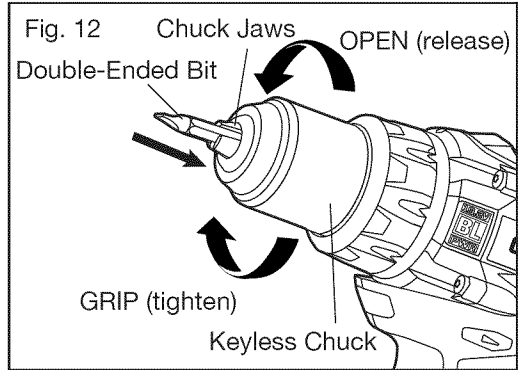

REMOVING BITS (Fig. 13)

1. Lock the trigger switch by placing the direction-of-rotation selector in the OFF (center-lock) position.
2. Open the chuck jaws.
3. Rotate the chuck in the direction of the arrow marked OPEN to loosen the chuck jaws.

NOTICE: Do not use a wrench to tighten or loosen the chuck jaws.

4. Remove the bit.

⚠ WARNING: Make sure to insert the bit straight into the chuck jaws. Do not insert the bit into the chuck jaws at an angle and then tighten. This could cause the bit to be thrown from the drill/driver, resulting in possible serious personal injury or damage to the chuck.

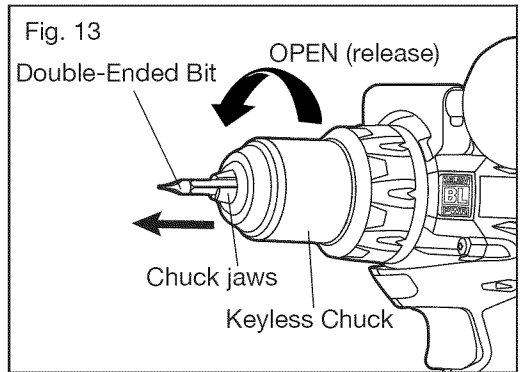

INSTALLING THE AUXILIARY HANDLE (Fig. 14)

1. Lock the trigger switch by placing the direction-of-rotation selector in the OFF (center-lock) position.
2. Loosen the auxiliary handle by turning the handle grip counter-clockwise until the hooks of the handle can easily slide into the slots on the gear case ring.
3. Slide the auxiliary handle hooks into the slots on the gear case ring.
4. Securely tighten the auxiliary handle by turning the grip clockwise.

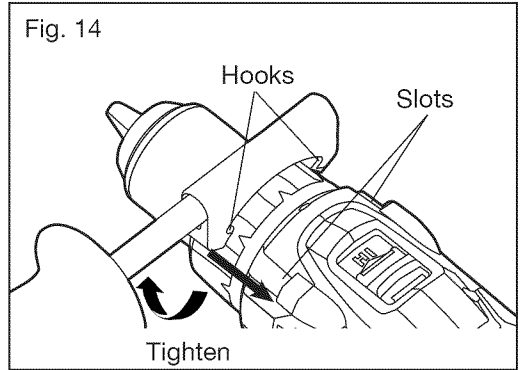

REMOVING THE AUXILIARY HANDLE

1. Lock the trigger switch by placing the direction-of-rotation selector in the OFF (center-lock) position.
2. Loosen the auxiliary handle by turning the handle grip counter-clockwise until the handle can be removed.
3. Remove the auxiliary handle.

DRILLING (Fig. 15)

1. Check that the direction-of-rotation selector is at the correct setting (forward or reverse).
2. Secure the material to be drilled in a vise or with clamps to keep it from turning as the drill bit rotates.
3. Hold the drill/driver firmly, and place the bit at the point to be drilled.
4. Depress the trigger switch to start the drill/driver.
5. Move the drill bit into the workpiece, applying only enough pressure to keep the bit cutting. Do not force the drill/driver or apply side pressure to elongate a hole. Let the tool do the work.
6. When drilling hard, smooth surfaces, use a center punch to mark the desired location of the hole. This will prevent the drill bit from slipping off-center as the hole is started.

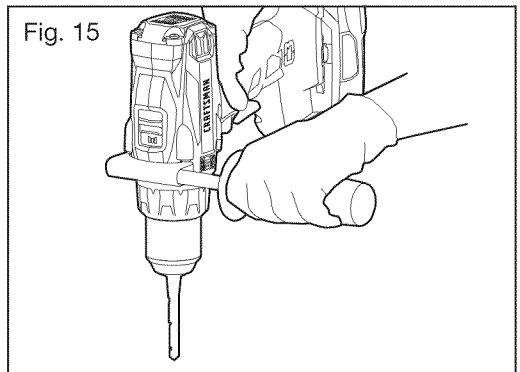

7. When drilling metals, use light oil on the drill bit to keep it from overheating. The oil will prolong the life of the bit and increase the drilling action.
8. If the bit jams in the workpiece or if the drill/driver stalls, stop the tool immediately. Remove the bit from the workpiece and determine the reason for jamming.

NOTICE: This drill/driver is equipped with an electric brake. When the brake is functioning properly, sparks may be visible through the vent slots in the housing. This is normal and results from the action of the brake.

WOOD DRILLING

For maximum performance, use high-speed steel or brad-point bits for wood drilling.

1. Begin drilling at a very low speed to prevent the bit from slipping off the starting point.
2. Increase speed as the drill bit bites into the material.
3. When drilling “through” holes, place a block of wood behind the workpiece to prevent ragged or splintered edges on the back side of the hole.

METAL DRILLING

For maximum performance, use high speed steel bits for metal or steel drilling.

1. When drilling metals, use light oil on the drill bit to keep it from overheating. The oil will prolong the life of the bit and increase the drilling action.
2. Begin drilling at a very low speed to prevent the bit from slipping off the starting point.
3. Maintain a speed and a pressure which allow cutting without overheating the bit. Applying too much pressure will:
 - Overheat the drill/driver
 - Wear the bearings
 - Bend or burn bits
 - Produce off-center or irregularly shaped holes

MAINTENANCE

⚠ WARNING: To avoid serious personal injury, always remove the battery pack from the tool when cleaning or performing any maintenance.

⚠ WARNING: Always wear safety goggles or safety glasses with side shields when using compressed air to clean the tool. If the operation is dusty, also wear a dust mask.

GENERAL MAINTENANCE

Avoid using solvents when cleaning plastic parts. Most plastics are susceptible to damage from various types of commercial solvents and may be damaged by their use. Use clean clothes to remove dirt, dust, oil, grease, etc.

⚠ WARNING: Do not at any time let brake fluids, gasoline, petroleum-based products, penetrating oils, etc. come in contact with plastic parts. Chemicals can damage, weaken or destroy plastic which may result in serious personal injury.

⚠ WARNING: When servicing, use only identical craftsman replacement parts. Use of any other parts may create a hazard or cause product damage. To ensure safety and reliability, all repairs should be performed by a qualified service technician.

CHUCK REMOVAL (Figs. 16 . 17 and 18)

The chuck can be removed and replaced with a new one.

1. Lock the trigger switch by placing the direction-of-rotation selector in the center position.

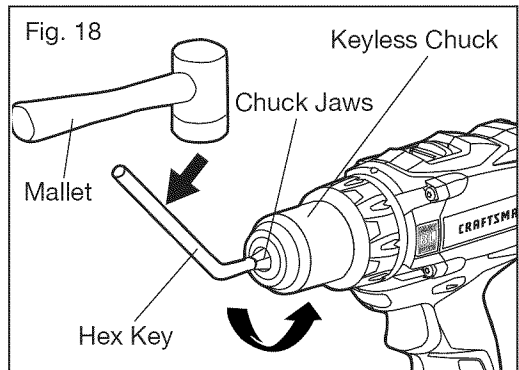
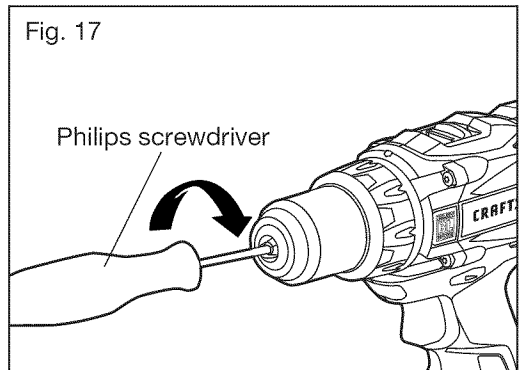
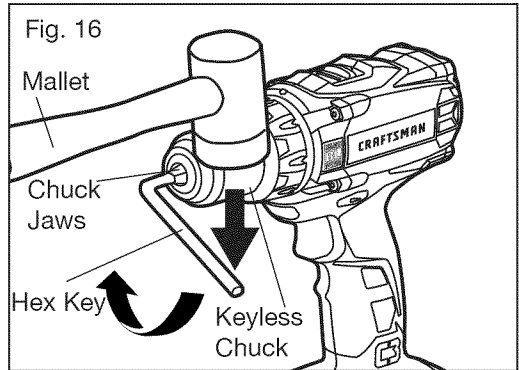

2. Open the chuck jaws.
3. Insert a 5/16 in. or larger hex key (available separately) into the chuck of the drill/driver and tighten the chuck jaws securely.
4. Tap the hex key sharply with a mallet (available separately) in a clockwise direction. This will loosen the screw in the chuck for easy removal.
5. Open the chuck jaws and remove the hex key. Using a Philips screwdriver (available separately), remove the chuck screw by turning it in a clockwise direction.

NOTICE: The chuck screw has left-handed threads.

6. Insert the hex key into the chuck and tighten the chuck jaws securely. Tap sharply with a mallet in a counterclockwise direction. This will loosen the chuck on the spindle. It can now be unscrewed by hand.

TO RETIGHTEN A LOOSE CHUCK

The chuck may become loose on the spindle and develop a wobble. Also, the chuck screw may become loose, causing the chuck jaws to bind and prevent them from closing.

To tighten a loose chuck or chuck screw:

1. Lock the trigger switch by placing the direction-of-rotation selector in the center position.
2. Open the chuck jaws.
3. Insert the hex key (available separately) into the chuck and tighten the chuck jaws securely. Tap the hex key sharply with a mallet (available separately) in a clockwise direction. This will tighten the chuck on the spindle.
4. Open the chuck jaws and remove the hex key.
5. Use a Philips screwdriver (available separately) to turn the chuck screw counterclockwise to tighten it.

 **WARNING:** Always wear safety glasses with side shields during maintenance.

 **WARNING:** To ensure safety and reliability, all repairs should be performed by a qualified service technician.

 **WARNING:** To avoid serious personal injury, always remove the battery pack from the drill/driver when cleaning or performing any maintenance.

TROUBLESHOOTING

PROBLEM	CAUSE	SOLUTION
The drill/driver does not work	Battery is depleted	Charge the battery
Bit cannot be installed	Chuck is not open	Open the chuck
Motor overheating	Be sure cooling vents are free from saw dust and obstacles	Clean, clear vents. Do not cover vents with hand during operation

PART LIST

1/2" Brushless Drill/Driver Model Number 320.38595

The Model Number will be found on the nameplate attached to the tool. Always mention the Model Number when ordering parts for this tool.

To order parts, call 1-800-469-4663.

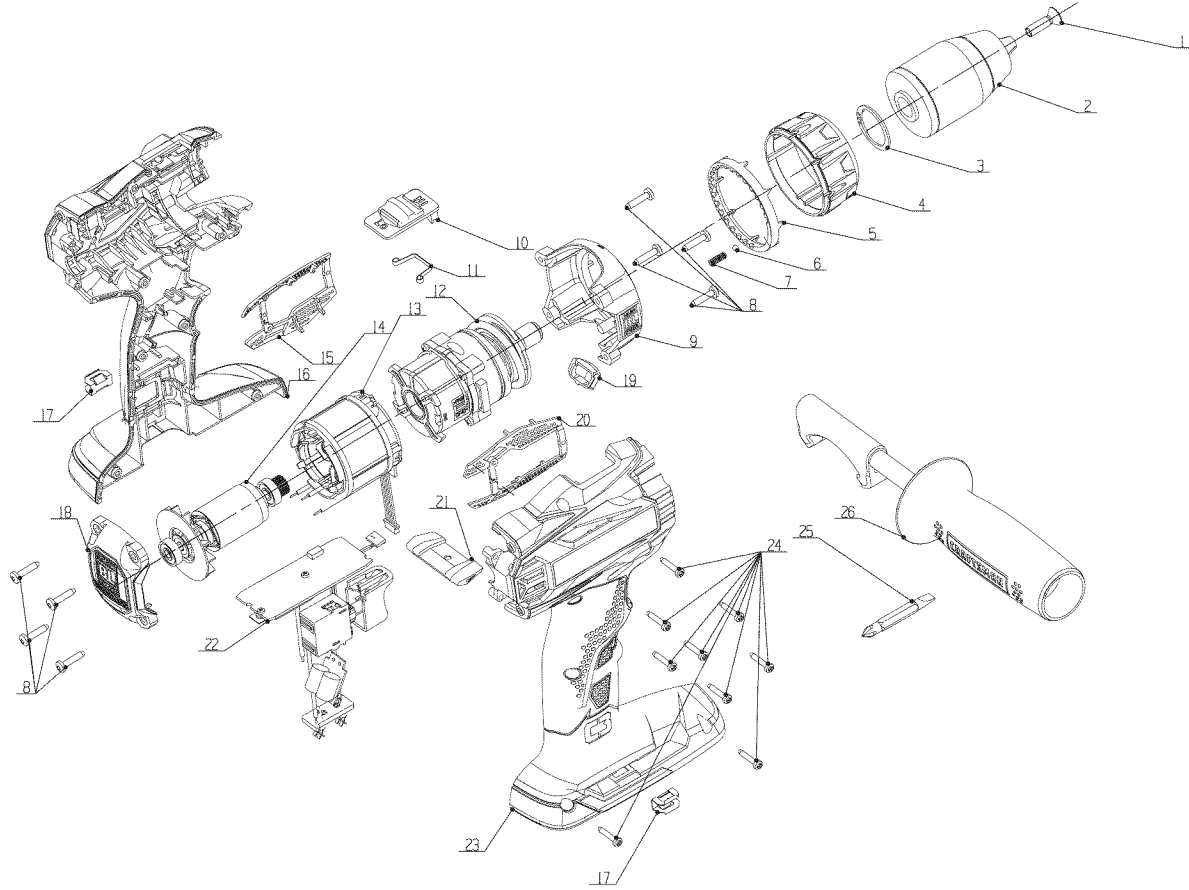

PART LIST

1/2" Brushless Drill/Driver Model Number 320.38595

The Model Number will be found on the nameplate attached to the tool. Always mention the Model Number when ordering parts for this tool.

To order parts, call 1-800-469-4663.

No	Part No	Part Name	QTY
1	5620488000	Screw (L.H.)	1
2	3860084000	Chuck	1
3	5660142000	Circlips For Shaft-Type B	1
4	3420765000	Clutch Cap	1
5	3124166000	Decorate Ring	1
6	5700178000	Steel Ball	1
7	3660466000	Compression Spring	1
8	5610225000	Hexagon Lobular Screw	8
9	3420643000	Front Cover	1
10	3123116000	Speed Change Button	1
11	3700961000	Stop Spring	1
12	2790351000	Gear Case Assembly	1
13	2823678000	Stator Assembly	1
14	2823677000	Rotor Assembly	1
15	3123819000	Left Mesh	1
16	3321741000	Left Housing Assembly	1
17	3703673000	Bits Holder	2
18	3321642000	Rear Cover Assembly	1
19	3123822000	Transparent Cap	1
20	3123820000	Right Mesh	1
21	2822828000	F/R Button	1
22	2830004000	Electric Assembly	1
23	3321742000	Right Housing Assembly	1
24	5610241000	Screw	9
25	3810126000	Screw Bit	1
26	2823679000	Auxiliary Handle Assembly	1

NOTICE

NOTICE

