

Operator's Manual

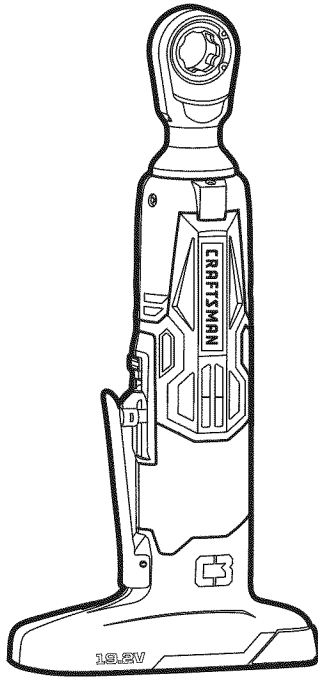

C3 MAX AXESS® AUTO RATCHET

Model No. 320.38596



▲ WARNING: To reduce the risk of injury, the user must read and understand the Operator's Manual before using this product.

- WARRANTY
- SAFETY
- DESCRIPTION
- ASSEMBLY
- OPERATION
- MAINTENANCE

Sears Brands Management Corporation, Hoffman Estates, IL 60179 U.S.A.

www.craftsman.com

TABLE OF CONTENTS

Warranty	Page 2
Safety Symbols	Pages 4-5
Safety Instructions	Pages 6-8
Description	Pages 9-10
Assembly	Page 10
Operation	Pages 11-14
Maintenance	Page 15
Troubleshooting	Page 15
Parts List	Pages 16-17

CRAFTSMAN ONE YEAR LIMITED WARRANTY

FOR ONE YEAR from the date of purchase, this product is warranted against any defects in material or workmanship. With proof of purchase, defective product will be replaced free of charge.

This ONE YEAR warranty does not cover the sockets and adaptor, which are covered by the Craftsman Hand Tool Full Warranty.

For complete warranty details, visit the web page : www.craftsman.com/warranty

This ONE YEAR warranty is void if this product is ever used while providing commercial services or if rented to another person. For 90 DAY commercial and rental use terms, see the Craftsman warranty web page.

This warranty gives you specific legal rights, and you may also have other rights which vary from state to state.

Sears Brands Management Corporation, Hoffman Estates, IL 60179

SAVE THESE INSTRUCTIONS!

READ ALL INSTRUCTIONS!

This auto ratchet has many features for making its use more pleasant and enjoyable. Safety, performance, and dependability have been given top priority in the design of this product, making it easy to maintain and operate.

⚠ DANGER: People with electronic devices, such as pacemakers, should consult their physician(s) before using this product. Operation of electrical equipment in close proximity to a heart pacemaker could cause interference or failure of the pacemaker.

⚠ WARNING: Some dust created by power sanding, sawing, grinding, drilling and other construction activities contains chemicals known to the state of California to cause cancer, birth defects or other reproductive harm. Some examples of these chemicals are:

- Lead from lead-based paints
- Crystalline silica from bricks and cement and other masonry products, and
- Arsenic and chromium from chemically-treated lumber.

Your risk from these exposures varies, depending on how often you do this type of work. To reduce your exposure to these chemical: work in a well ventilated area, and work with approved safety equipment, such as those dust masks that are specially designed to filter out microscopic particles.

SAFETY SYMBOLS

The purpose of safety symbols is to attract your attention to possible dangers.

The safety symbols and the explanations with them deserve your careful attention and understanding. The symbol warnings do not, by themselves, eliminate any danger. The instructions and warnings they give are no substitutes for proper accident prevention measures.

⚠ WARNING: Be sure to read and understand all safety instructions in this manual, including all safety alert symbols such as “**DANGER,**” “**WARNING,**” and “**CAUTION**” before using this tool. Failure to follow all instructions listed in this manual may result in electric shock, fire, and/or serious personal injury.

SYMBOL SIGNAL MEANING

SAFETY ALERT SYMBOL: Indicates **DANGER, WARNING, or CAUTION;** may be used in conjunction with other symbols or pictographs.

⚠ DANGER: Indicates a hazardous situation which, if not avoided, will result in death or serious injury.

⚠ WARNING: Indicates a hazardous situation which, if not avoided, could result in death or serious injury.

⚠ CAUTION: Indicates a hazardous situation which, if not avoided, could result in minor or moderate injury.

Damage prevention and Information Messages

These inform the user of important information and/or instructions that could lead to equipment or other property damage if they are not followed. Each message is preceded by the word “NOTICE”, as in the example below.

NOTICE: Equipment and/or property damage may result if these instructions are not followed.



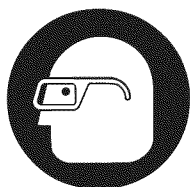



⚠ WARNING: To ensure safety and reliability, all repairs should be performed by a qualified service technician.



⚠ WARNING: The operation of any power tools can result in foreign objects being thrown into your eyes, which can result in severe eye damage. Before beginning power tool operation, always wear safety goggles or safety glasses with side shield and a full face shield when needed. We recommend a Wide Vision Safety Mask for use over eyeglasses or standard safety glasses with side shields. Always use eye protection which is marked to comply with ANSI Z87.1.

SAVE THESE INSTRUCTIONS

Some of these following symbols may be used on this tool. Please study them and learn their meaning. Proper interpretation of these symbols will allow you to operate the tool better and more safely.

SYMBOL	NAME	DESIGNATION/EXPLANATION
V	Volts	Voltage
A	Amperes	Current
Hz	Hertz	Frequency (cycles per second)
W	Watt	Power
min	Minutes	Time
	Alternating Current	Type of current
	Direct Current	Type or a characteristic of current
n_0	No-load Speed	Rotational speed, at no load
	Class II Construction	Double-insulated construction
.../min	Per Minute	Revolutions, strokes, surface speed, orbits, etc., per minute
	Wet Conditions Alert	Do not expose to rain or use in damp locations.
	Read The Operator's Manual	To reduce the risk of injury, user must read and understand operator's manual before using this product.
	Eye Protection	Always wear safety goggles or safety glasses with side shields and a full face shield when operating this product.
	Safety Alert	Precautions that involve your safety.
	No-Hands Symbol	Failure to keep your hands away from the blade will result in serious personal injury.
	No-Hands Symbol	Failure to keep your hands away from the blade will result in serious personal injury.
	No-Hands Symbol	Failure to keep your hands away from the blade will result in serious personal injury.
	No-Hands Symbol	Failure to keep your hands away from the blade will result in serious personal injury.
	Hot Surface	To reduce the risk of injury or damage, avoid contact with any hot surface.

SAFETY INSTRUCTIONS

GENERAL POWER TOOL SAFETY WARNINGS

▲ WARNING: Read all safety warnings and instructions. Failure to follow the warnings and instructions may result in electric shock, fire and/or serious injury.

Save all warnings and instructions for future reference.

The term “power tool” in the warnings refers to your mains-operated (corded) power tool or battery-operated (cordless) power tool.

WORK AREA SAFETY

- **Keep work area clean and well lit.** Cluttered or dark areas invite accidents.
- **Do not operate power tools in explosive atmospheres, such as in the presence of flammable liquids, gases or dust.** Power tools create sparks which may ignite the dust or fumes.
- **Keep children and bystanders away while operating a power tool.** Distractions can cause you to lose control.

ELECTRICAL SAFETY

- **Power tool plugs must match the outlet. Never modify the plug in any way. Do not use any adaptor plugs with earthed (grounded) power tools.** Unmodified plugs and matching outlets will reduce risk of electric shock.
- **Avoid body contact with earthed or grounded surfaces such as pipes, radiators, ranges and refrigerators.** There is an increased risk of electric shock if your body is earthed or grounded.
- **Do not expose power tools to rain or wet conditions.** Water entering a power tool will increase the risk of electric shock.
- **Do not abuse the cord. Never use the cord for carrying, pulling or unplugging the power tool. Keep cord away from heat, oil, sharp edges or moving parts.** Damaged or entangled cords increase the risk of electric shock.
- **When operating a power tool outdoors, use an extension cord suitable for outdoor use.** Use of a cord suitable for outdoor use reduces the risk of electric shock.
- **If operating a power tool in a damp location is unavoidable, use a ground fault circuit interrupter (GFCI) protected supply.** Use of a GFCI reduces the risk of electric shock.

PERSONAL SAFETY

- **Stay alert, watch what you are doing and use common sense when operating a power tool. Do not use tool while tired or under the influence of drugs, alcohol, or medication.** A moment of inattention while operating power tools may result in serious personal injury.
- **Use personal protective equipment. Always wear eye protection.** Protective equipment such as dust mask, non-skid safety shoes, hard hat, or hearing protection used for appropriate conditions will reduce personal injuries.
- **Prevent unintentional starting. Ensure the switch is in the off-position before connecting to power source and/or battery pack, picking up or carrying the tool.** Carrying power tools with your finger on the switch or energizing in power tools that have the switch on invites accidents.
- **Remove any adjusting key or wrench before turning the power tool on.** A wrench or a key left attached to a rotating part of the power tool may result in personal injury.
- **Do not overreach. Keep proper footing and balance at all times.** This enables better control of the power tool in unexpected situations.
- **Dress properly. Do not wear loose clothing or jewellery. Keep your hair, clothing and gloves away from moving parts.** Loose clothes, jewellery or long hair can be caught in moving parts.
- **If devices are provided for the connection of dust extraction and collection facilities, ensure these are connected and properly used.** Use of these devices can reduce dust-related hazards.

POWER TOOL USE AND CARE

- **Do not force the power tool. Use the correct power tool for your application.** The correct power tool will do the job better and more safely at the rate for which it was designed.
- **Do not use the power tool if the switch does not turn it on and off.** Any power tool that cannot be controlled with the switch is dangerous and must be repaired.
- **Disconnect the plug from the power source and/or the battery pack from the power tool before making any adjustments, changing accessories, or storing power tools.** Such preventive safety measures reduce the risk of starting the power tool accidentally.
- **Store idle power tools out of the reach of children and do not allow persons unfamiliar with the power tool or these instructions to operate the power tool.** Power tools are dangerous in the hands of untrained users.
- **Maintain power tools. Check for misalignment or binding of moving parts, breakage of parts and any other condition that may affect the power tool's operation. If damaged, have the power tool repaired before use.** Many accidents are caused by poorly maintained power tools.

- **Keep cutting tools sharp and clean.** Properly maintained cutting tools with sharp cutting edges are less likely to bind and are easier to control.
- **Use the power tool, accessories, tool bits, etc. in accordance with these instructions, taking into account the working conditions and the work to be performed.** Use of the power tool for operations different from those intended could result in a hazardous situation.

BATTERY TOOL USE AND CARE

- **Recharge only with the charger specified by the manufacturer.** A charger that is suitable for one type of battery pack may create a risk of fire when used with another battery pack.
- **Use power tools only with specifically designated battery packs.** Use of any other battery packs may create a risk of injury and fire.
- **When the battery pack is not in use, keep it away from other metal objects, like paper clips, coins, keys, nails, screws or other small metal objects that can make a connection from one terminal to another.** Shorting the battery terminals together may cause burns or a fire.
- **Under abusive conditions, liquid may be ejected from the battery; avoid contact. If contact accidentally occurs, flush with water. If liquid contacts eyes, additionally seek medical help.** Liquid ejected from the battery may cause irritation or burns.

SERVICE

- **Have your power tool serviced by a qualified repair person using only identical replacement parts.** This will ensure that the safety of the power tool is maintained.
- **Follow instructions in the Maintenance section of this manual.** Use of unauthorized parts or failure to follow Maintenance instructions may create a risk of shock or injury.

SPECIFIC SAFETY RULES FOR AUTO RATCHET

- **Hold power tools by insulated gripping surfaces when performing an operation where the tool may contact hidden wiring or its own cord.** Contact with a “live” wire will also make exposed metal parts of the tool “live” and shock the operator.

DESCRIPTION

KNOW YOUR AUTO RATCHET (Fig. 1)

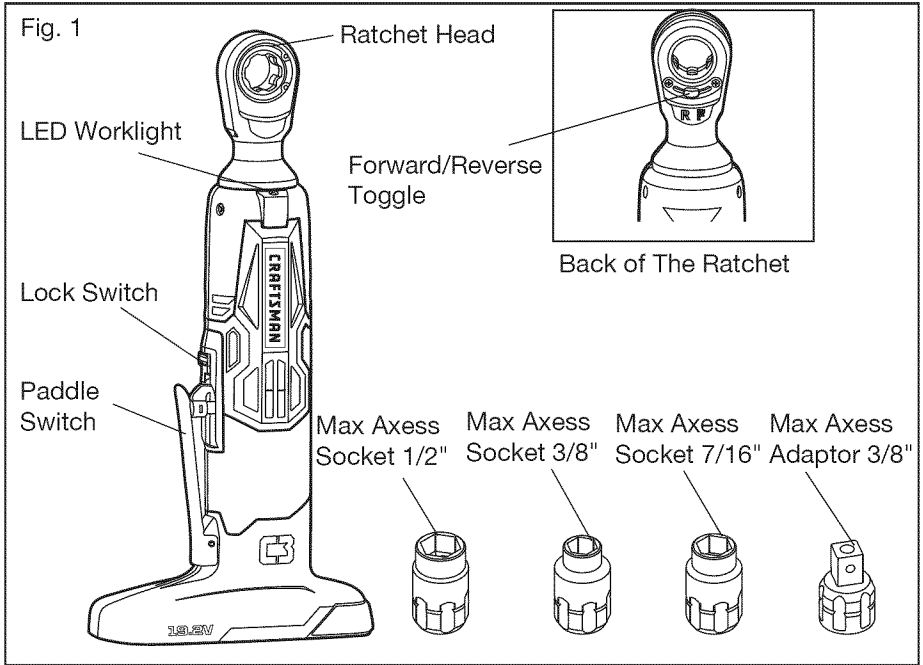

PRODUCT SPECIFICATIONS

Motor	19.2 Volt DC
No-load speed	0-225 RPM
Torque Range	360 in.lbs.

⚠ WARNING: The safe use of this product requires an understanding of the information on the tool and in this operator's manual, as well as knowledge of the project you are attempting. Before using this product, familiarize yourself with all operating features and safety rules.

VARIABLE SPEED

The variable-speed paddle switch delivers higher speed with increased pressure and lower speed with decreased pressure.

FORWARD/REVERSE TOGGLE

The forward/reverse toggle located on the head of the auto ratchet changes the direction of rotation.

LED WORKLIGHT

The LED worklight, located below the ratchet head, illuminates when the paddle switch is depressed. This feature provides extra light for increased visibility.

ASSEMBLY

⚠ WARNING: If any parts are broken or missing, do not attempt to attach the battery pack or operate the auto ratchet until the broken or missing parts are replaced. Failure to do so could result in possible serious injury.

⚠ WARNING: Do not attempt to modify this auto ratchet or create accessories not recommended for use with this auto ratchet. Any such alteration or modification is misuse and could result in a hazardous condition leading to possible serious injury.

⚠ WARNING: To prevent accidental starting that could cause serious personal injury, always remove the battery pack from the tool when not in use.

UNPACKING

This product has been shipped completely assembled.

- Carefully remove the tool and any accessories from the carton. Make sure that all items listed in the packing list are included.
- Inspect the tool carefully to make sure no breakage or damage occurred during shipping.
- Do not discard the packing material until you have carefully inspected and satisfactorily operated the tool.
- If any parts are damaged or missing, please return the tool to the place of purchase.

PACKING LIST

Max Axess Auto Ratchet, Max Axess sockets: 1/2", 7/16" and 3/8"; Max Axess adaptor 3/8" and operator's manual.

OPERATION

TO ATTACH BATTERY PACK (AVAILABLE SEPARATELY) (Fig. 2)

1. Set the lock switch in the locked position before attaching the battery pack, as shown in Fig. 3.
2. Align the raised rib on battery pack with groove inside the auto ratchet, and then insert the battery pack into the tool.

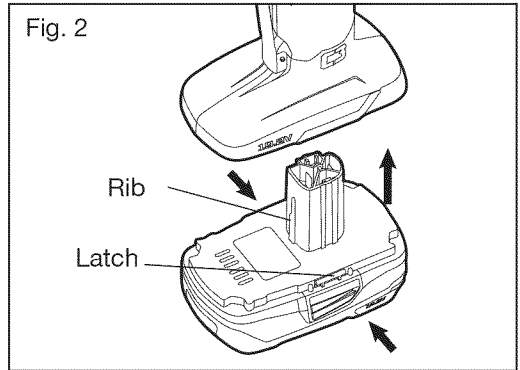

NOTICE: Make sure that the latch on the battery pack snaps into place and the battery pack is secured to the tool before beginning operation. Improper assembly of the battery pack can cause damage to internal components.

TO DETACH BATTERY PACK (Fig. 2)

1. Set the lock switch in the locked position before detaching the battery pack.
2. Depress both battery-release buttons located on the sides of the battery pack to release the battery pack.
3. Pull the battery pack out and remove it from the tool.

LOCK SWITCH (Fig. 3)

To lock the paddle switch, slide the lock switch to the locked position. To unlock the paddle switch, slide the lock switch to the unlocked  position. The paddle switch will not work when the lock switch is in the locked position.

⚠ WARNING: Always lock the paddle switch or remove the battery pack before performing maintenance, changing accessories, storing the tool and any time the tool is not in use.

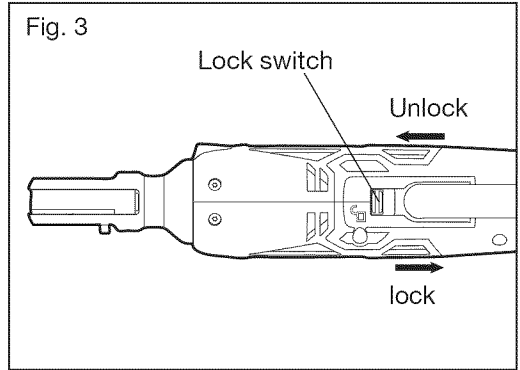

PADDLE SWITCH (Fig. 4)

1. Set the lock switch to the unlocked position.
2. To turn the auto ratchet ON, depress the paddle switch.
3. To turn it OFF, release the switch.

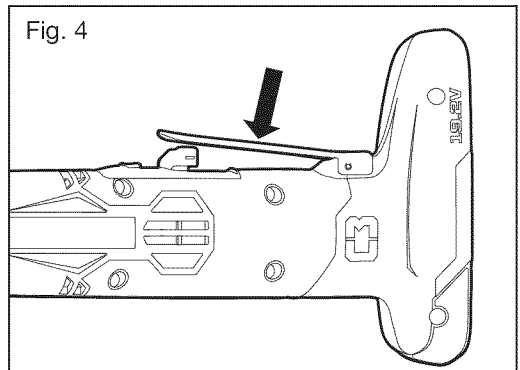

LED WORKLIGHT (Fig. 5)

The LED worklight, located below the auto ratchet head, will turn on when the paddle switch is depressed. The LED worklight will turn off when the switch is released. This provides additional lighting on the surface of the workpiece for operation in lower-light areas.

VARIABLE SPEED

The variable speed paddle switch delivers higher speed with increased paddle switch pressure and lower speed with decreased switch pressure.

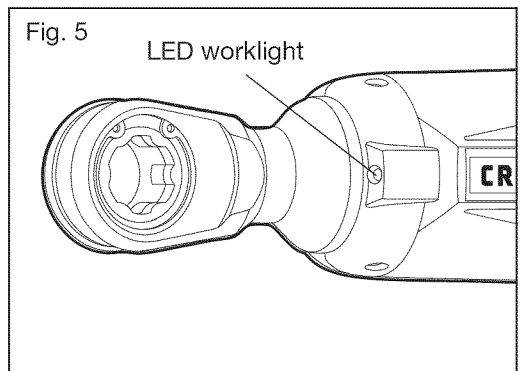

FORWARD/REVERSE TOGGLE (Fig. 6)

The direction of rotation is reversible and is controlled by a toggle located on the auto ratchet head. With the auto ratchet held as shown in Fig. 6.

For forward rotation, set the forward/reverse toggle to the position marked “F.” For reverse rotation, set the forward/reverse toggle to the position marked “R.”

⚠ WARNING: Never change the direction of rotation when the tool is operating.

ATTACHING AND REMOVING THE SOCKET

1. Use only sockets of appropriately fitting design, within the recommended size range of 3/8 in. to 7/8 in.
2. Set the lock switch at the locked position.
3. To attach the socket, hold the auto ratchet in the normal operating position, as shown in Fig. 7.
4. Align the grooves on the socket with the raised ribs in the auto ratchet head. From beneath the auto ratchet head (same side as the LED worklight), insert the socket into the auto ratchet head as far as possible; you will hear a “click” to indicate that the socket is locked in place (Fig. 7).

NOTICE: Make sure that the socket is locked at the same side of the tool as the LED worklight so that the LED worklight can illuminate the working area.

5. To remove the socket, press it from the top of the auto ratchet head.

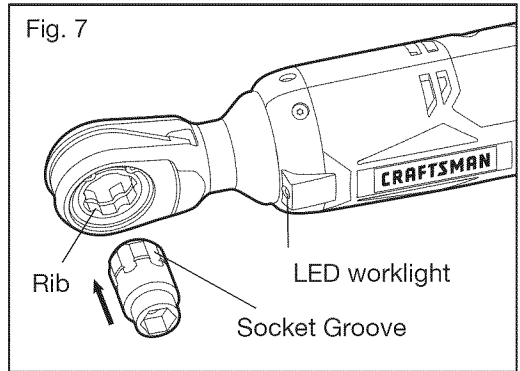
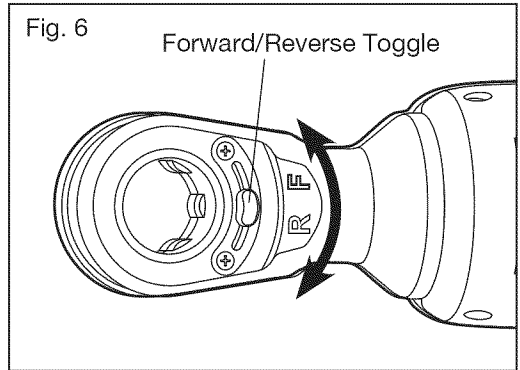

ATTACHING AND REMOVING THE ADAPTOR

1. Set the lock switch in the locked position.

2. To attach the adaptor, hold the auto ratchet in the normal operating position, as shown in Fig. 8.

3. Align the grooves on the adaptor with the raised ribs in the auto ratchet head. Insert the adaptor into the auto ratchet head as far as possible from the opposite side of the LED light; you will hear a “click” to indicate that the adaptor is locked in place (Fig. 8).

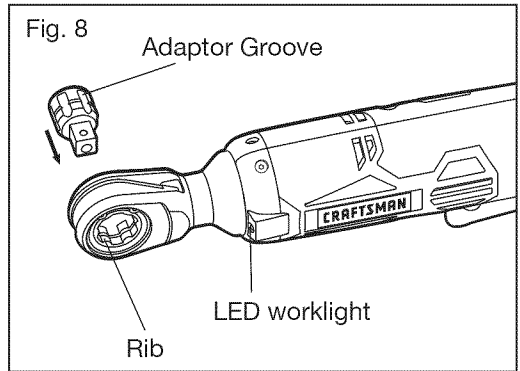

4. To remove the adaptor, push it from the bottom of the auto ratchet head.

ATTACHING AND REMOVING A SQUARE SOCKET (AVAILABLE SEPARATELY) (Fig. 9)

1. Set the lock switch in the locked position.

2. Choose a suitable square socket (depends on the bit to be used).

3. Attach the adaptor in the auto ratchet head.

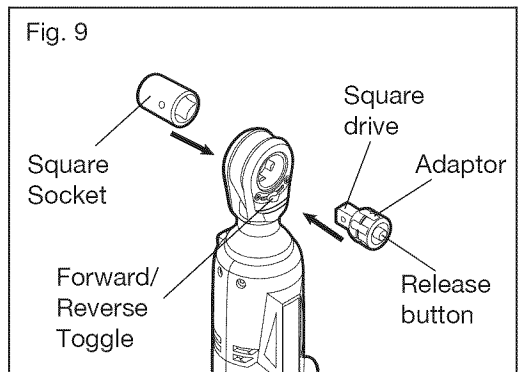

4. Depress the steel retention-ball release button on the adaptor.

5. Slide the square socket onto the square drive of the adaptor until it locks into place.

6. To remove the square socket, depress the steel retention-ball release button on the adaptor (Fig. 9) and pull the square socket off.

TIGHTENING HEX BOLTS AND NUTS (Fig. 10)

1. Install the correct socket to match the hex bolt or nut.
2. Apply just enough pressure to keep the socket engaged on the hex bolt or nut.
3. Position the forward/reverse toggle in the correct position for forward rotation.
4. Initially apply minimal pressure to the paddle switch. Increase the speed only when full control can be maintained.

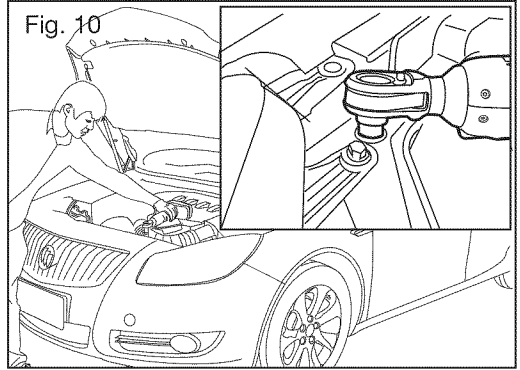

NOTICE: Do not over-tighten, as the force of the auto ratchet can break the fastener. Keep the socket at a right angle to the fastener to avoid damaging the fastener head.

LOOSENING HEX BOLTS AND NUTS (Fig. 10)

1. Install the correct socket to match the hex bolt or nut.
2. Apply just enough pressure to keep the socket engaged on the hex bolt or nut.
3. Position the forward/reverse toggle in the correct position for reverse rotation.
4. Initially apply minimal pressure to the paddle switch. Increase the speed only when full control can be maintained.

MAINTENANCE

⚠ WARNING: To avoid serious personal injury, always remove the battery pack from the tool when cleaning or performing any maintenance.

⚠ WARNING: Always wear safety goggles or safety glasses with side shields when using compressed air to clean the tool. If the operation is dusty, also wear a dust mask.

GENERAL MAINTENANCE

Avoid using solvents when cleaning plastic parts. Most plastics are susceptible to damage from various types of commercial solvents and may be damaged by their use. Use clean cloths to remove dirt, dust, oil, grease, etc.

⚠ WARNING: Do not at any time let brake fluids, gasoline, petroleum-based products, penetrating oils, etc. come in contact with plastic parts. Chemicals can damage, weaken or destroy plastic which may result in serious personal injury.

⚠ WARNING: When servicing, use only identical Craftsman replacement parts. Use of any other parts may create a hazard or cause product damage. To ensure safety and reliability, all repairs should be performed by a qualified service technician.

TROUBLESHOOTING

PROBLEM	CAUSE	SOLUTION
Socket cannot be attached	Improper socket	Use suitable socket
Socket cannot engage the fastener	The socket is worn	Replace it with a new socket
The auto ratchet does not work	Battery is depleted	Charge the battery pack

PART LIST

MAX AXESS AUTO RATCHET MODEL NUMBER 320.38596

The Model Number will be found on the nameplate attached to the handle of the tool. Always mention the Model Number when ordering parts for this tool.

To order parts, call 1-800-469-4663.

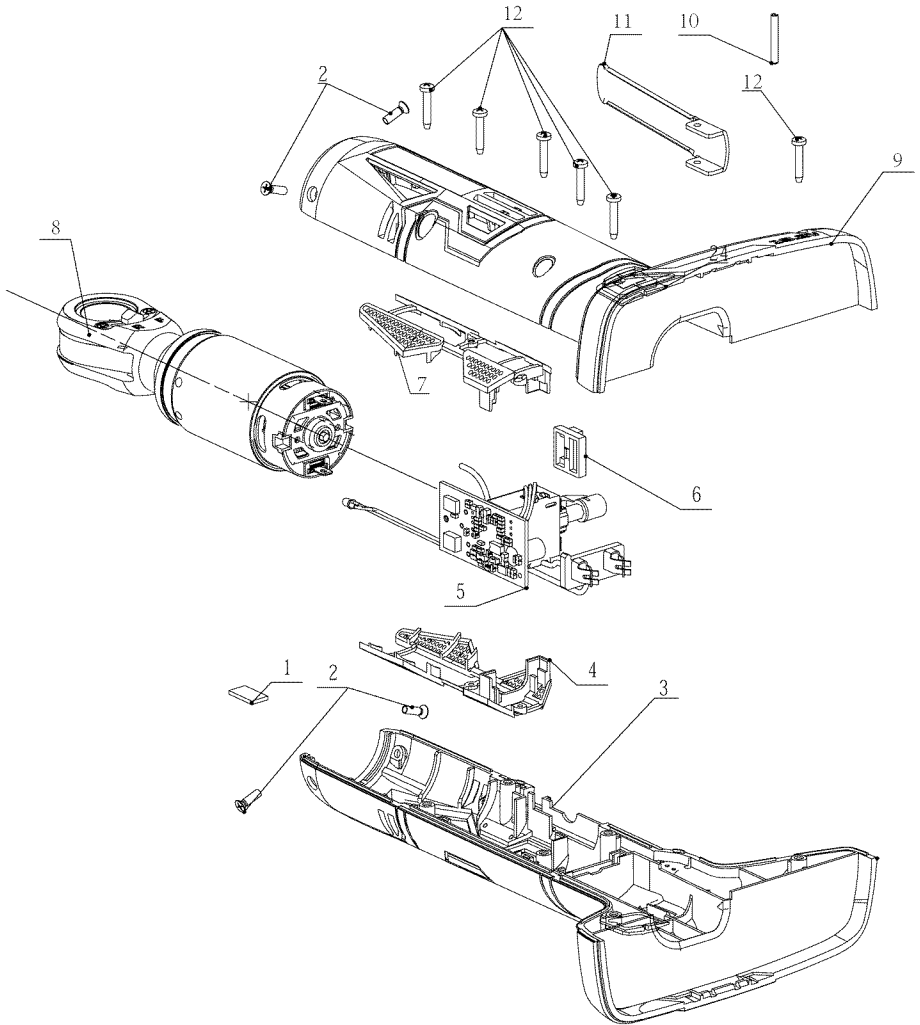

PART LIST

MAX AXESS AUTO RATCHET MODEL NUMBER 320.38596

The Model Number will be found on the nameplate attached to the handle of the tool. Always mention the Model Number when ordering parts for this tool.

To order parts, call 1-800-469-4663.

No	Part No	Part Name	Quantity
1	3704820000	Sponge Pad	1
2	5620498000	Screw	4
3	3321739000	Left Housing Assembly	1
4	3127155000	Left Mesh	1
5	2830016000	Electric Assembly	1
6	3127140000	Lock Button	1
7	3127153000	Right Mesh	1
8	2790339000	Motor and Gear Case Assembly	1
9	3321740000	Right Housing Assembly	1
10	5670246000	Spring Pin	1
11	3705544000	Switch Trigger	1
12	5610241000	Tapping Screw	6