

Operator Manual



Z6700 ZERO TURN MOWER

24 HP* 54" Mower

Model No.
917.204140

**as rated by the manufacturer*

For answers to your
questions about this product

Call:

1-800-659-5917

Sears Craftsman Help Line

5 am - 5 pm, Mon - Sat

Visit our Craftsman website:

www.sears.com/craftsman

Please read the operator manual carefully and make sure you
understand the instructions before using the machine

Gasoline containing up to 10% ethanol (E10) is acceptable for use in
this machine. The use of any gasoline exceeding 10% ethanol (E10)
will void the product warranty..

CRAFTSMAN FULL WARRANTY

FOR TWO YEARS from the date of purchase, all non-expendable parts of this riding equipment are warranted against any defects in material or workmanship. A defective non-expendable part will receive free in-home repair or replacement if repair is impossible.

BATTERY LIMITED WARRANTY

FOR 90 DAYS from the date of purchase, the battery (an expendable part) of this riding equipment is warranted against any defects in material or workmanship. A new battery will be supplied free of charge. You are responsible for the labor cost of battery installation.

WARRANTY SERVICE

For warranty coverage details to obtain free repair or replacement,

call **1-800-659-5917** or

visit the web page:

www.craftsman.com/warranty

In all cases above, if part repair or replacement is impossible, the riding equipment will be replaced free of charge with the same or an equivalent model.

All of the above warranty coverage is void if this riding equipment is ever used while providing commercial services or if rented to another person.

This warranty covers ONLY defects in material and workmanship. Warranty coverage does NOT include:

- Expendable parts (except battery) that can wear out from normal use within the warranty period, including but not limited to blades, spark plugs, air cleaners, belts, and oil filters.
- Standard maintenance servicing, oil changes, or tune-ups.
- Tire replacement or repair caused by punctures from outside objects, such as nails, thorns, stumps, or glass.
- Tire or wheel replacement or repair resulting from normal wear, accident, or improper operation or maintenance.
- Repairs necessary because of operator abuse, including but not limited to damage caused by towing objects beyond the capability of the riding equipment, impacting objects that bend the frame, axle assembly or crankshaft, or over-speeding the engine.
- Repairs necessary because of operator negligence, including but not limited to, electrical and mechanical damage caused by improper storage, failure to use the proper grade and amount of engine oil, failure to keep the deck clear of flammable debris, or failure to maintain the riding equipment according to the instructions contained in the operator manual.
- Engine (fuel system) cleaning or repairs caused by fuel determined to be contaminated or oxidized (stale). In general, fuel should be used within 30 days of its purchase date.
- Normal deterioration and wear of the exterior finishes, or product label replacement.

This warranty gives you specific legal rights, and you may also have other rights which vary from state to state.

Sears Brands Management Corporation, Hoffman Estates, IL 60179

CONTENTS

INTRODUCTION	5	Stopping the Engine	21
Driving and Transport on Public Roads.....	5	Mowing Tips	21
Towing.....	5	Operating On Hills	22
Operating.....	5	Headlights	22
Good Service.....	5	Weak Battery	22
Manufacturing Number	5	Jumper Cable Use.....	22
SYMBOLS AND DECALS	6	Battery Voltage Light	23
SAFETY	7	Moving Machine By Hand	23
Safety Instructions	7	MAINTENANCE.....	24
Personal Safety Equipment	7	Maintenance Schedule.....	24
Slope Operation.....	8	Battery	26
Safe Handling of Gasoline.....	8	Safety System.....	27
General Maintenance	9	Park Brake	27
Transport.....	10	Tire Pressures	27
Towing.....	10	Caster Wheels	28
Spark Arrestor.....	10	Anti-scalp Rollers.....	28
CONTROLS.....	11	V-belts.....	28
Control Locations.....	11	Deck Belt Removal	28
Steering Control Levers	12	Adjusting the Mower Deck	29
Park brake	12	Leveling deck	29
Throttle Control	13	Cutting Blades.....	30
Cold Weather Control	13	Blade replacement	30
Ignition Switch	13	Cleaning	30
Complete Start Courtesy Buttons	13	Hardware	30
Blade Switch.....	14	LUBRICATION.....	31
Service Minder.....	14	Transmission.....	31
Fuse	14	Wheel and Deck Zerks	31
Seat Adjustment Lever	14	Front Wheel Mount.....	31
Fuel Shut Off Valve	14	Front Wheel Bearings	31
Cutting Height Lever.....	15	Deck Spindles	31
Bypass Linkages	15	TROUBLESHOOTING	32
Tracking	15	STORAGE	33
Fuel Tank.....	16	Winter Storage	33
OPERATION	17	Service.....	33
Training	17	SCHEMATIC.....	34
Steering	17	TECHNICAL DATA	35
Complete Start Ignition	17	Torque Specifications	36
Before Starting.....	18	Accessories.....	36
Starting the Engine	18	SERVICE JOURNAL.....	37
Ignition System Faults.....	20		
Running	20		

CONFORMITY CERTIFICATES

USA requirements

Labels are placed on the engine and/or in the engine compartment stating that the machine will fulfill the requirements. This is also applicable to special requirements for any of the states, (California emission rules etc.). Do not remove any of these labels. Certificates can also be supplied with the machine at delivery or written in the Engine manual. Take care of them as they are valuable documents.

To implement improvements, specifications and designs can be altered without prior notification.

Note that no legal demands can be placed based on the information contained in these instructions.

Use only original parts for repairs. The use of other parts voids the warranty.

Do not modify or install non-standard equipment to the unit without consent from the manufacturer. Modifications to the unit may cause unsafe operations or damage the unit.

When this product is worn out and no longer used, it should be returned to the reseller or other party for recycling.



WARNING! Battery posts, terminals and related accessories contain lead and lead compounds, chemicals known to the State of California to cause cancer and birth defects or other reproductive harm. Wash hands after handling.



WARNING! Engine exhaust, some of its constituents, and certain vehicle components contain or emit chemicals known to the State of California to cause cancer and birth defects or other reproductive harm.



WARNING! Failure to follow cautious operating practices can result in serious injury to the operator or other persons. The owner must understand these instructions, and must allow only trained persons who understand these instructions to operate the mower.

Each person operating the mower must be of sound mind and body and must not be under the influence of any mind altering substance.

INTRODUCTION

Congratulations

Thank you for purchasing a Craftsman ride-on mower. This machine is built for superior efficiency to rapidly mow primarily large areas. A control panel easily accessible to the operator and a hydrostatic transmission regulated by steering controls both contribute to the machine's performance.

This manual is a valuable document. Read the contents carefully before using or servicing the machine. The following of instructions (use, service, maintenance) by all who operate this machine is important for the safety of the operator and others. It can also considerably increase the life span of the machine and increase its resale value.

If you sell your machine, be sure to give the operator manual to the new owner.

The final chapter of this operator manual provides a Service Journal. Ensure that service and repair work are documented. A well-kept service journal reduces service costs for the maintenance and affects the machine's resale value. Please contact your dealer for more information. Take the operator manual along when the machine is taken to your dealer for service.

General

In this operator manual, left and right, backward and forward are used in relation to the machine's normal driving direction. Continuous dedication to improve our products require that specifications and design are subject to change without notice.

Driving and Transport on Public Roads

Check applicable road traffic regulations before transporting on public roads. If the machine is transported, you must always use approved fastening equipment and ensure that the machine is well anchored. DO NOT operate this machine on public roadways.

Towing

If machine is equipped with a tow hitch, use extreme caution when towing. Never allow children or others in or on the towed equipment. Make wide turns to avoid jack-knifing. Travel slowly and allow extra distance to stop.

Do not tow on sloped ground. The weight of the towed equipment may cause loss of traction and loss of control.

Follow the manufacturer's recommendation for weight limits for towed equipment. Do not tow near ditches, canals, and other hazards.

Operating

This machine is constructed only for mowing grass on lawns and even ground without obstacles such as stones, tree stumps, etc. The machine can also be used for other tasks when equipped with special accessories provided by the manufacturer. Operating instructions for the accessories are provided with delivery. All other types of uses are incorrect. The manufacturer's directions concerning operation, maintenance, and repairs must be carefully followed.

Lawn mowers and all power equipment, can be potentially dangerous if used improperly. Safety requires good judgement, careful use in accordance with these instructions and common sense.

The machine must only be operated, maintained, and repaired by persons familiar with the machine's special characteristics and who are also knowledgeable about the safety instructions. Use only approved repair parts to maintain this machine.

Accident prevention regulations, other general safety regulations, occupational safety rules, and traffic regulations must be followed without fail.

Unauthorized modifications to the design of the machine may absolve the manufacturer from liability for any resulting personal injury or property damage.

Good Service

Craftsman products are sold only in specialized retail stores with complete service. This ensures that you as a customer receive only the best support and service. Before the product is delivered, the machine has, for example, been inspected and adjusted by your retailer. See the certificate in the Service Journal in this operator manual.

Manufacturing Number

The machine's manufacturing number can be found on the printed plate affixed to the engine compartment.

Stated on the plate, from the top are:

- The machine's type designation (I.D.).
- The manufacturer's type number (Model).
- The machine's serial number (Serial no.)

Please have the type designation and serial number available when ordering spare parts.

The engine's manufacturing number is stamped on one of the valve covers.

The plate states:

- The engine's model.
- The engine's type.
- Code

Please have these available when ordering spare parts.

The wheel motors and hydrostatic pumps have a barcode decal affixed at the rear.

SYMBOLS AND DECALS

These symbols are found on the machine and in the operator manual.

Study them carefully so that you know what they mean.

 **WARNING!**
 Xxxx xxxxxx xxxxxx xxxx xxxxxxxxxxx xxxxxx xxxxxxxxxxx. xx
 xxxxxxxxxxx xxxx xxxxxx.

Used in this publication to notify the reader of a risk of personal injury or death, particularly if the reader should neglect to follow instructions given in the manual.

IMPORTANT INFORMATION Xxxx xxxxxx xxxxxx xxxx
 xxxxxxxxxxx xxxxxx xxxxxxxxxxx. xx xxxxxxxxxxx xxxx xxxxxx.

Used in this publication to notify the reader of a risk of material damage, particularly if the reader should neglect to follow instructions given in the manual. Used also when there is a potential for misuse or misassembly.



Reverse



Neutral



Fast



Slow



Cold Weather Start



Fuel



Warning!



Park Brake



Do not stand here



Use protective glasses



Use protective gloves



Danger. Keep hands and feet away

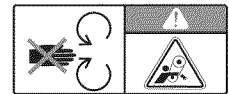

Do not touch parts



Battery acid is corrosive, explosive and flammable

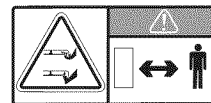

Warning!
 Rotating blades, keep away from the discharge deck











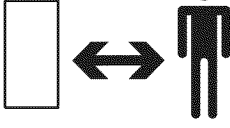

Read Operator Manual

Shut off engine before performing maintenance or repair

Keep a safe distance from the machine

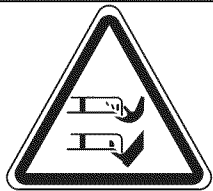
Use on slopes no greater than 10°

No passengers

Whole body exposure to thrown objects

Severing of fingers and toes

Do not open or remove safety shields with engine running

Careful backing up, watch for other people

Careful going forward, watch for other people

SAFETY

Safety Instructions

These instructions are for your safety. Read them carefully.

General Operation

WARNING! THIS CUTTING MACHINE IS CAPABLE OF AMPUTATING HANDS AND FEET AND THROWING OBJECTS. FAILURE TO OBSERVE THE FOLLOWING SAFETY INSTRUCTIONS COULD RESULT IN SERIOUS INJURY OR DEATH.

- Read, understand, and follow all instructions on the machine and in the manual before starting.
- It is recommended that someone be aware that you are mowing and can provide help in case of injury or accident.
- Do not put hands or feet near rotating parts or under the machine. Keep clear of the discharge opening at all times.
- Only allow responsible adults, who are familiar with the instructions, to operate the machine.
- Clear the area of objects such as rocks, toys, wire, etc., which could be picked up and thrown by the blades.
- Be sure the area is clear of bystanders before operating. Stop machine if anyone enters the area.
- Do not mow in reverse unless absolutely necessary. Always look down and behind before and while backing.
- Never direct discharged material toward anyone. Avoid discharging material against a wall or obstruction. Material may ricochet back toward the operator. Stop the blades when crossing gravel surfaces.
- Do not operate machine without the entire grass catcher, discharge guard, or other safety devices in place and working.
- Slow down before turning.
- Never leave a running machine unattended. Always turn off blades, set park brake, stop engine, and remove keys before dismounting.
- Never carry passengers. The machine is only intended for use by one person.
- Disengage blades when not mowing. Shut off engine and wait for all parts to come to a complete stop before cleaning the machine, removing the grass catcher, or unclogging the discharge guard.
- Operate machine only in daylight or good artificial light.
- Do not operate the machine while under the influence of alcohol or drugs.

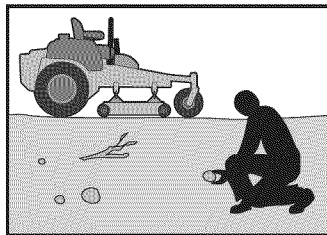
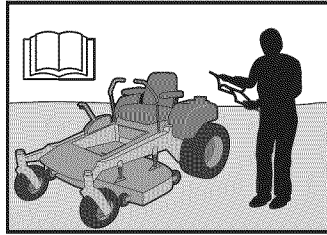

- Watch for traffic when operating near or crossing roadways.
- Use extra care when loading or unloading the machine into a trailer or truck.
- Always wear eye protection when operating machine.
- Wear proper Personal Protective Equipment (PPE) while operating this machine, including (at a minimum) sturdy footwear, eye protection, and hearing protection. Do not mow in shorts and/or footwear with open toes.
- Data indicates that operators age 60 years and above are involved in a large percentage of riding mower-related injuries. These operators should evaluate their ability to operate the riding mower safely enough to protect themselves and others from serious injury.
- Follow the manufacturer's recommendation for wheel weights or counterweights.
- Anyone who operates this machine must first read and understand this Operation Manual. Local laws may regulate the age of the user.
- Keep machine free of grass, leaves or other debris buildup which can touch hot exhaust or engine parts and burn. Do not allow the mower deck to plow leaves or other debris which can cause buildup to occur. Clean any oil or fuel spillage before operating or storing the machine.
- Allow machine to cool before storage.

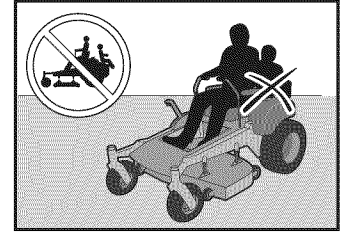

Personal Safety Equipment

- Make sure that first aid equipment is close at hand when using the machine.
- Never use the machine when barefoot.
- Always wear protective shoes or boots, preferably with steel toe caps.
- Always wear approved protective glasses or a full visor when assembling or driving.
- Always wear gloves when handling the blades.
- Never wear loose clothing that can get caught in moving parts.
- Use ear protectors to avoid damage to hearing.

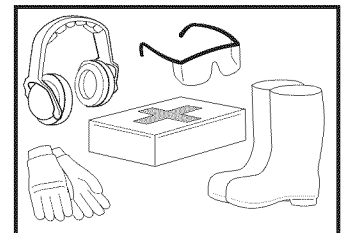

WARNING! When using the machine, approved personal protective equipment should be used. Personal protective equipment cannot eliminate the risk of injury but it will reduce the degree of injury if an accident does happen. Ask your retailer for help in choosing the right equipment.

SAFETY

Slope Operation

Slopes are a major factor related to loss of control and tip-over accidents, which can result in severe injury or death. Operation on all slopes requires extra caution. If you cannot back up the slope or if you feel uneasy on it, do not mow it.

- Mow up and down slopes (10 degrees maximum), not across.
- Watch for holes, ruts, bumps, rocks, or other hidden objects. Uneven terrain could overturn the machine. Tall grass can hide obstacles.
- Choose a low ground speed so that you will not have to stop while on the slope.
- Do not mow on wet grass. Tires may lose traction.
- Avoid starting, stopping, or turning on a slope. If the tires lose traction, disengage the blades and proceed slowly straight down the slope.

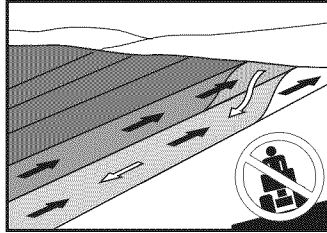

WARNING! Do not drive up or down hills with slopes greater than 10 degrees. And do not drive across any slopes.

- Keep movement on the slopes slow and gradual. Do not make sudden changes in speed or direction, which could cause machine to roll over.
- Use extra care while operating machine with grass catchers or other attachments; they can affect the stability of the machine.
- Do not use on steep slopes.
- Do not try to stabilize the machine by putting a foot on the ground.
- Do not mow near drop-offs, ditches, or embankments. The machine could suddenly roll over if a wheel is over the edge or the edge caves in.

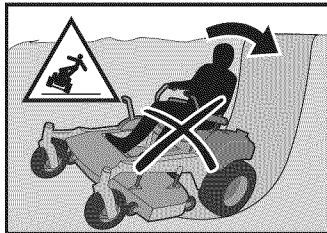

WARNING! CHILDREN CAN BE INJURED BY THIS EQUIPMENT. The American Academy of Pediatrics recommends that children be a minimum of 16 years of age before operating a riding lawn mower.

Children

Tragic accidents can occur if the operator is not alert to the presence of children. Children are often attracted to the machine and the mowing activity. *Never* assume that children will remain where you last saw them.

- Keep children out of the mowing area and in the watchful care of a responsible adult other than the operator.
- Be alert and turn machine off if a child enters the area.
- Before and while backing, look behind and down for small children.
- Never carry children, even with the blades shut off. They may fall off and be seriously injured or interfere with safe machine operation. Children who have been given rides in the past may suddenly appear in the mowing area for another ride and be run over or backed over by the machine.
- Never allow children to operate the machine.
- Use extra care when approaching blind corners, shrubs, trees, or other objects that may block your view of a child.

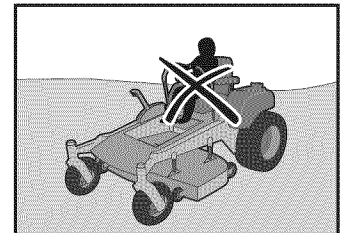

Safe Handling of Gasoline

To avoid personal injury or property damage, use extreme care in handling gasoline. Gasoline is extremely flammable and the vapors are explosive.

- Extinguish all cigarettes, cigars, pipes, and other sources of ignition.
- Use only approved gasoline containers.
- Never remove gas cap or add fuel with the engine running. Allow engine to cool before refueling.
- Never fuel the machine indoors.
- Never store the machine or fuel container where there is an open flame, spark, or pilot light such as on a water heater or other appliance.
- Before you begin refueling, minimize the risk of static electricity by touching a metal surface.

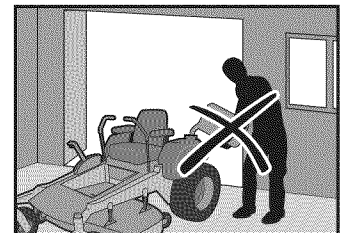

SAFETY

- Never fill containers inside a vehicle or on a truck or trailer bed with plastic liner. Always place containers on the ground away from the vehicle when filling.
- Remove gas-powered equipment from the truck or trailer and refuel it on the ground. If this is not possible, refuel such equipment with a portable container, rather than from a gasoline dispenser nozzle.
- Keep the nozzle in contact with the rim of the fuel tank or container opening at all times until fueling is complete. Do not use a nozzle lock-open device.
- If fuel is spilled on clothing, change clothing immediately.
- Never overfill fuel tank. Replace gas cap and tighten securely.
- Do not start the engine near spilled fuel.
- Never use gasoline as a cleaning agent.
- If leaks arise in fuel system, engine must not be started until problem has been resolved.
- Check the fuel level before each use and leave space for the fuel to expand, as the heat from the engine and the sun may otherwise cause the fuel to expand and overflow.

General Maintenance

WARNING! The engine and the exhaust system become very hot during operation.

There is risk for burns if touched.

Allow engine and exhaust system to cool before refueling.

- Never operate machine in a closed area.
- Keep all nuts and bolts tight to be sure the equipment is in safe working condition.
- Maintain or replace safety and instruction labels, as necessary.
- Never tamper with safety devices. Check their proper operation regularly.
- Do not modify safety equipment. Check regularly to be sure it works properly. The machine must not be driven with defective or unmounted protective plates, protective cowlings, safety switches, or other protective devices.
- Do not change the settings of governors and avoid running the engine with overly high engine speeds. If you run the engine too fast, you risk damaging the machine components.
- Keep machine free of grass, leaves, or other debris buildup. Clean oil or fuel spillage and remove any fuel-soaked debris. Allow machine to cool before storing.
- If you strike a foreign object, stop and inspect the machine. Repair, if necessary, before restarting.
- Never make any adjustments or repairs with the engine running.
- Check grass catcher components and the discharge guard frequently and replace with manufacturer's recommended parts, when necessary.

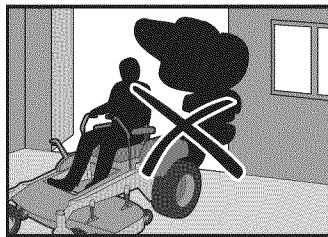

WARNING! The engine must not be started when the driver's floor plate or any protective plate for the mower deck's drive belt is removed.

- Mower blades are sharp. Wrap the blade or wear gloves, and use extra caution when servicing them.
- Check brake operation frequently. Adjust and service as required.
- Make sure that the equipment is in good condition and that all nuts and bolts, especially those fastening the blade attachments, are properly tightened and torqued.
- Ensure that the fuel filler cap is mounted tightly and no flammable substances are stored in an open vessel.
- Never work with the starter circuit if there is spilled fuel.
- Sparking can occur when working with the battery and the heavy cables of the starter circuit. This can cause battery explosion, fire or eye injury. Sparking will not occur after the grounding cable (normally negative, black) is removed from the battery. Disconnect the grounding cable from the battery first and reconnect it last.
- Do not make a bridge short circuit across the starter relay to run the starter.
- Be very careful when handling battery acid. Acid on skin can cause serious corrosive burns. If you spill battery acid on your skin, rinse immediately with water.

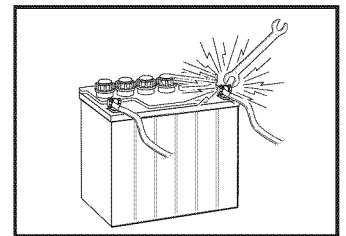

WARNING!

The battery contains lead and lead compounds, chemicals that are considered to cause cancer, birth defects, and other reproductive system damage. Wash your hands after handling the battery.

- Acid in the eyes can cause blindness, contact a doctor immediately.
- Be careful when servicing the battery. Explosive gases form in the battery. Never perform maintenance on the battery when smoking or near open flames or sparks.
- The battery can explode and cause serious injury or damage.
- Never use the machine indoors or in spaces lacking proper ventilation. The exhaust fumes contain carbon monoxide, an odorless, poisonous, and lethal gas.
- Stop to inspect the equipment if you run over or into anything. If necessary, make repairs before starting.
- Never make adjustments with the engine running.

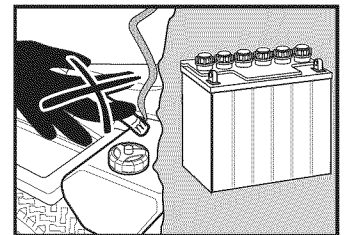

SAFETY

- The machine is tested and approved only with the equipment originally provided or recommended by the manufacturer. Only use approved repair parts for the machine.
- The blades are sharp and can cause cuts and gashes. Wrap the blades or use protective gloves when handling them.



CAUTION! Use protective glasses for maintenance work.

- Check the park brake's functionality regularly. Adjust and service as necessary.
- The mulch blades should only be used in familiar areas when higher quality mowing is desired.
- Reduce the risk of fire by removing grass, leaves, and other debris that may have accumulated on the machine.
- Allow the machine to cool before putting it in storage.
- Regularly clean deck and underside of deck, avoid spraying engine and electrical components with water.

Transport



WARNING!

Use extreme caution when loading the machine into a truck or trailer using ramps. There is the possibility of serious injury or death if the machine falls off the ramps.

IMPORTANT INFORMATION The park brake is not sufficient to lock the machine in place during transport. Ensure that the machine is well fastened to the transport vehicle. Always reverse the machine onto the transport vehicle to avoid tipping it over.

- The machine is heavy and can cause serious crushing injuries. Be extra cautious when it is loaded on or unloaded from a vehicle or trailer.
- Use an approved trailer to transport the machine. Activate the park brake, turn off the fuel supply, and fasten the machine with approved fastening devices, such as bands, chains, or straps, when transporting.
- Do not operate this machine on public roadways.
- Check and abide by local traffic regulations before transporting the machine on any road.
- Do not tow this machine, it may cause damage to the drive system.
- Do not tow any trailers, etc. with this mower. They may jackknife or overturn causing damage to the mower and possibly serious injury to the operator.
- Load the unit onto truck or trailer by driving up ramps of suitable strength using a slow speed. Do not lift! The machine is not intended to be lifted by hand.
- When loading or unloading this machine, do not exceed the maximum recommended operation angle of 10°.

Towing

If machine is equipped with a tow hitch, use extreme caution when towing. Never allow children or others in or on towed equipment..

Make wide turns to avoid jack-knifing. Travel slowly and allow extra distance to stop. Do not tow on sloped ground. The weight of the towed equipment may cause loss of traction and loss of control.

Follow the manufacturer's recommendation for weight limits for towed equipment. Do not tow near ditches, canals, and other hazards.

Spark Arrestor

This mower is equipped with an internal combustion engine and should not be used on or near any unimproved forested, bush covered or grassy lands unless the engine's system is equipped with a spark arrestor meeting applicable local or state laws (if any).

Federal laws apply on federal lands.

If a spark arrestor is used, it should be maintained in effective working order by the operator.

A spark arrestor for the muffler is available through your authorized Craftsman dealer.



WARNING!

Engine exhaust and certain vehicle components contain or emit chemicals considered to cause cancer, birth defects, or other reproductive system damage. The engine exhaust contains carbon monoxide, which is an odorless, colorless, poisonous gas. Do not use the machine in enclosed spaces.

CONTROLS

This operator manual describes the Craftsman Zero Turn Rider. The rider is fitted with a Briggs & Stratton four-stroke overhead valve engine.

Transmission from the engine is made via a belt-driven hydraulic pumps. Using the left and right steering controls, the flow is regulated and thereby the direction and speed.

Control Locations

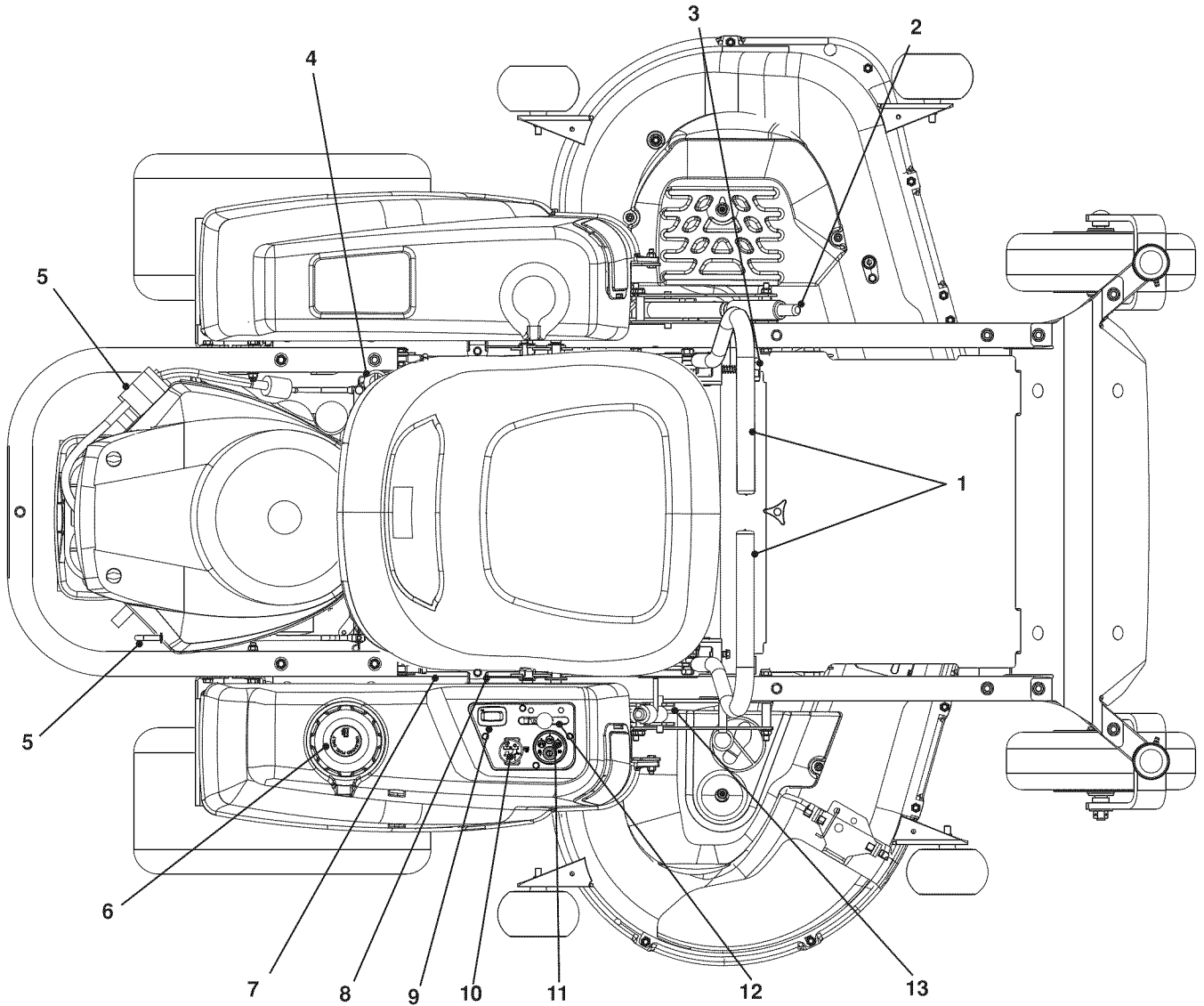

- | | |
|----------------------------|-------------------------------|
| 1. Steering control levers | 8. Seat adjustment lever |
| 2. Park brake | 9. Service minder |
| 3. Tracking adjustment | 10. Blade switch |
| 4. Fuel shut off valve | 11. Craftsman Complete Start™ |
| 5. Bypass Linkages | 12. Throttle |
| 6. Fuel tank | 13. Deck lift |
| 7. Fuse | |

CONTROLS

Steering Control Levers

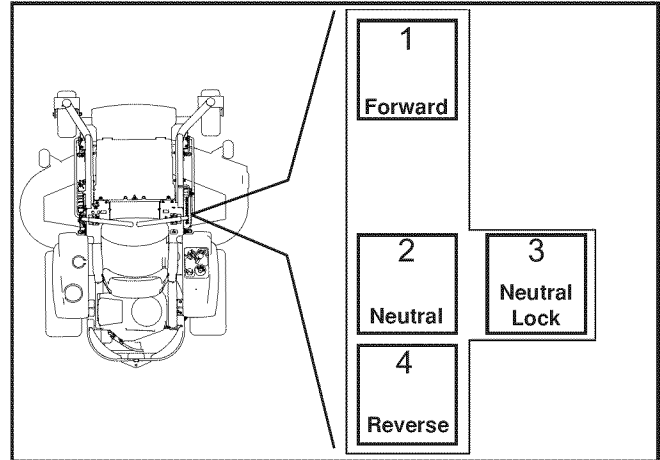
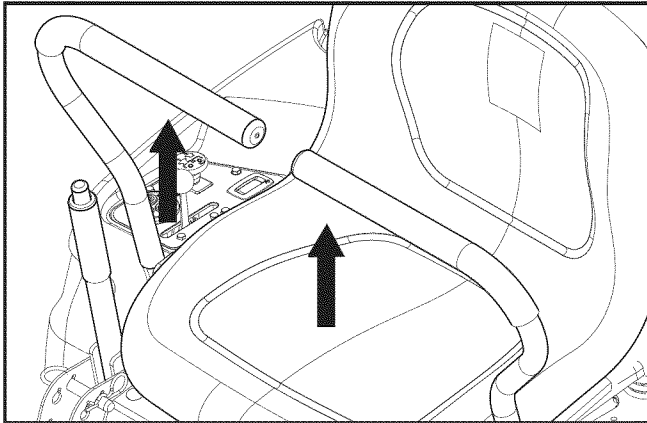

The machine's speed and direction are continuously variable using the two steering controls. The steering controls can be moved forward or backward about a neutral position. Furthermore, there is a neutral position, which is locked if the steering controls are moved outward.

When both controls are in the neutral position (N), the machine stands still.

By moving both controls an equal amount forward or backward, the machine moves in a straight line forward or backward respectively.

For example, to turn right while moving forward, move the right control towards the neutral position. The rotation of the right wheel is reduced and the machine turns to the right.

WARNING!

The machine can turn very rapidly if one steering control is moved much further forward than the other.

Zero turn can be achieved by moving one control backward (behind the neutral position) and carefully moving the other steering control forward from its neutral position. The rotation direction when zero turning is determined by which steering control is moved backward behind the neutral position. If the left steering control is pulled backward, the machine turns to the left. Use extra care when using this maneuver.

If the steering controls are in uneven positions when standing still or do not fit in the slots for moving the controls outward, they can be adjusted.

Park brake

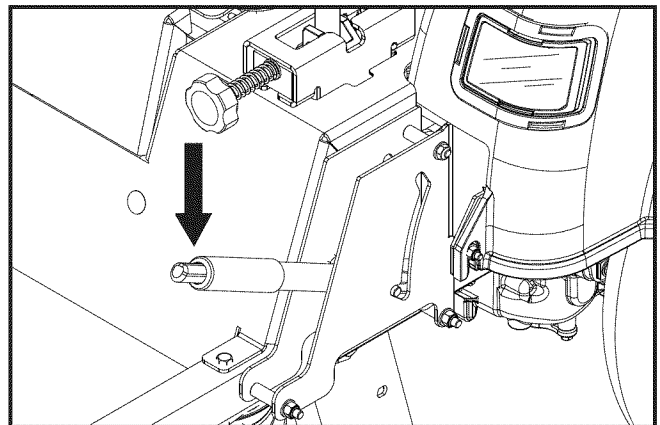

The park brake is found on the left of the machine. Push the release button and pull the lever backward to activate the brake—push forward to release it.

IMPORTANT INFORMATION The machine must stand absolutely still when applying the park brake. Always set the park brake before dismounting. Release the park brake before moving the mower.

CONTROLS

Throttle Control

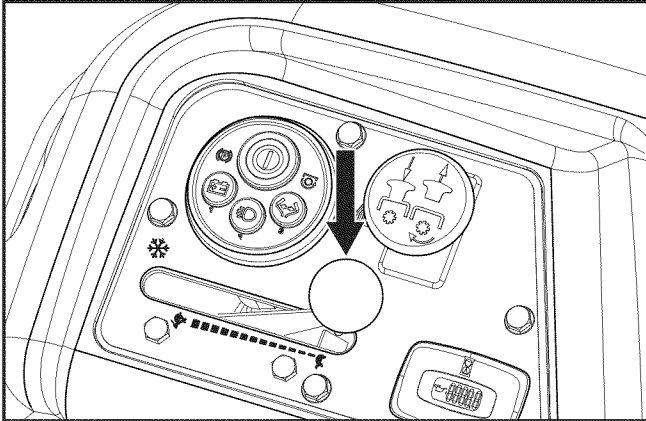

The throttle control regulates the engine speed and thereby the rate of rotation of the blades, assuming the blade switch is pulled out, see **Blade Switch**.

To increase or decrease the engine speed, the control is moved forward or back respectively.

Avoid idling the engine for long periods, as there is a risk of fouling the spark plugs. USE FULL THROTTLE WHEN MOWING, for best mower performance and battery charging.

Cold Weather Control

In temperatures below 32°F, move the throttle control forward past the start detent to the snowflake symbol. Once the engine has started, slowly move the throttle control back to the full throttle position.

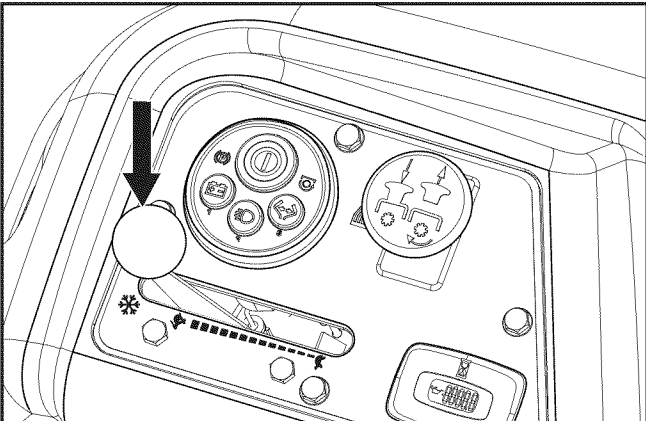

Ignition Switch

The ignition switch is placed on the control panel and is used to start and stop the engine.

See **Complete Start Ignition** and **Starting** in the *Operation* section for instructions.

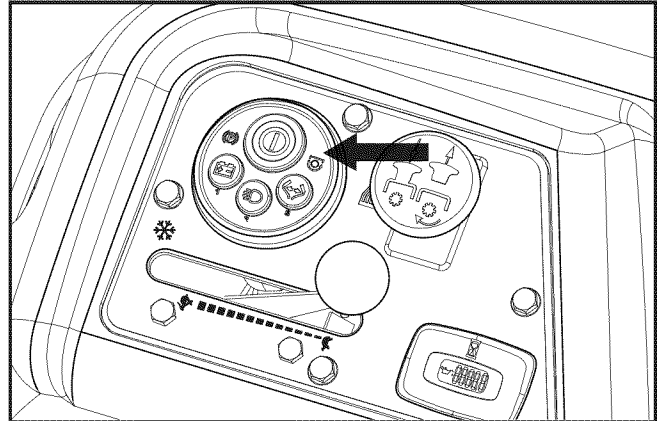

Complete Start Courtesy Buttons

A battery voltage light indicates that voltage is below the normal operating power.

Button 1 can be used to check the battery condition. See **Battery Voltage Light** in the *Operation* section.

Button 2 will turn on/off the headlights. See **Headlights** in the *Operation* section.

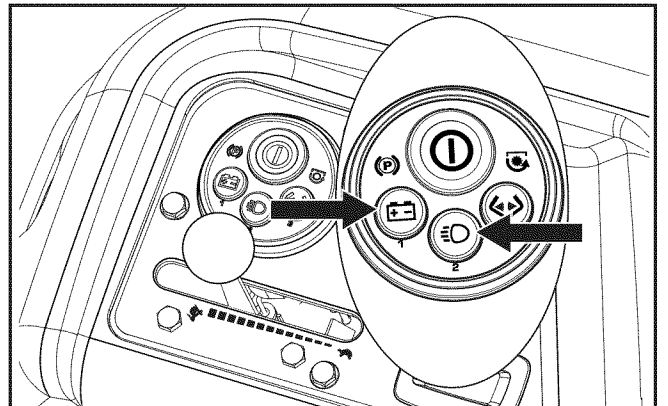

CONTROLS

Blade Switch

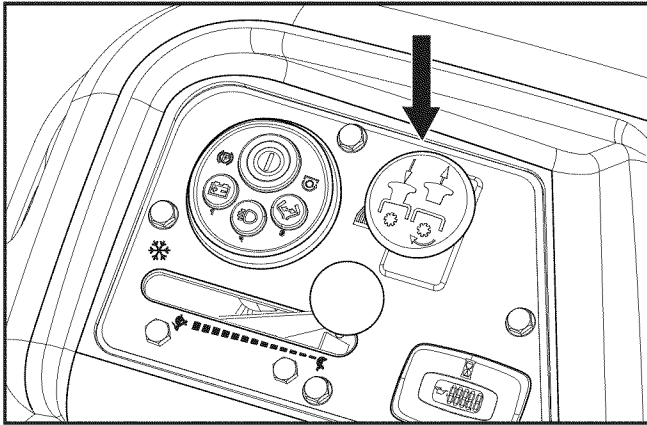

To engage the mower deck, pull the knob up; mower blades are disengaged when the knob is pressed down.

Fuse

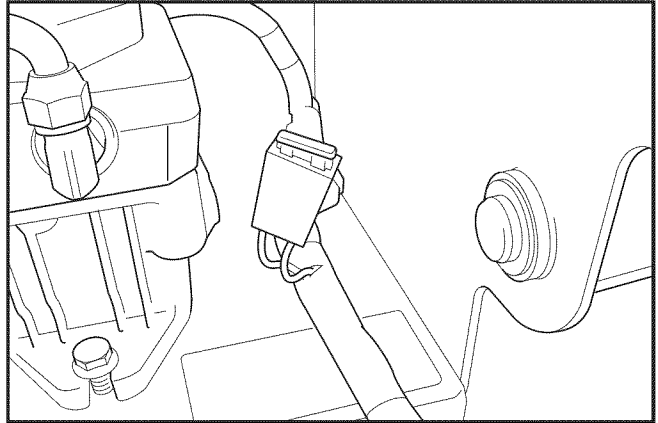

The 20 amp primary fuse is located on the left hand side of the machine. It is accessed by tilting the seat forward. The fuse is a flat pin type used in automobiles.

Service Minder

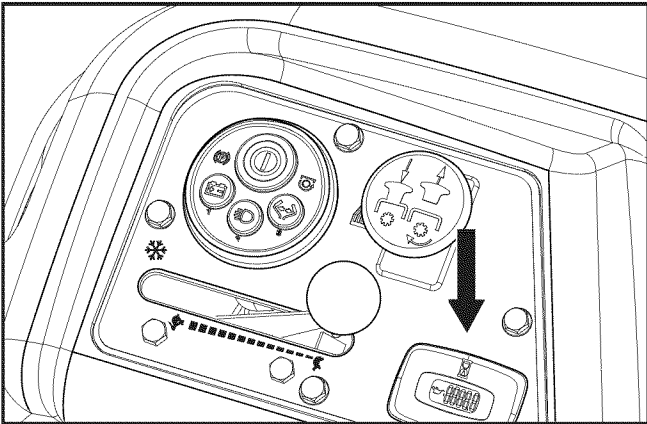

The service minder displays the total number of hours the engine has run and indicates when the engine and mower need servicing.

After every 50 hours of operation, an oil can icon will appear and stay on for two hours, before an automatic reset occurs. To service the engine and mower, see the Service Journal of this manual.

Note: The service minder operates (clocks hours) only when the engine is running or when the Complete Start is active (unlocked).

Seat Adjustment Lever

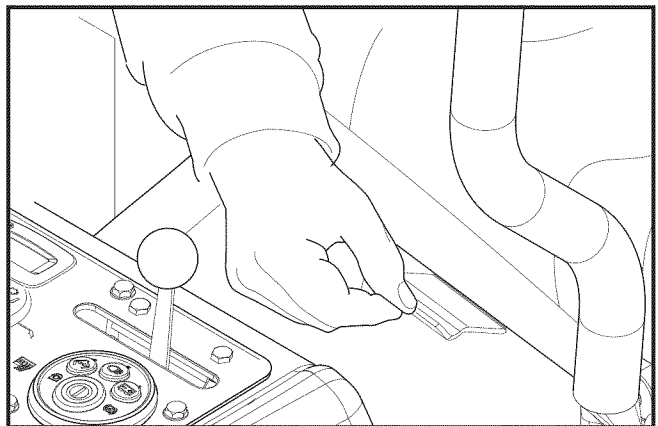

The seat can be adjusted lengthways. When making adjustments, the lever under the right side of the seat is pulled up, after which the seat can be moved backward or forward.

Fuel Shut Off Valve

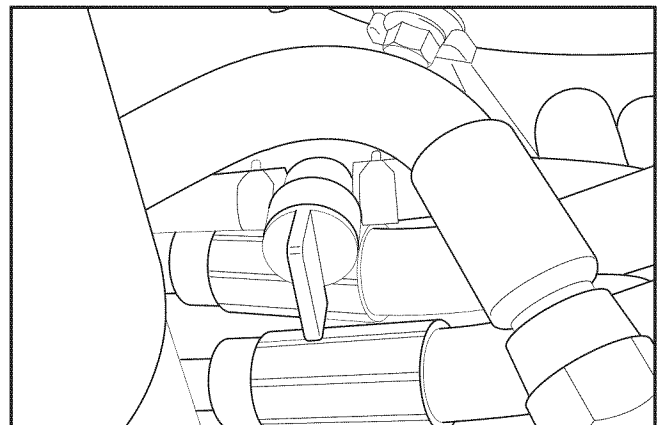

The fuel shut off valve is located at the left rear of the seat. The valve is off when the handle tab is turned perpendicular to the fuel line.

CONTROLS

Cutting Height Lever

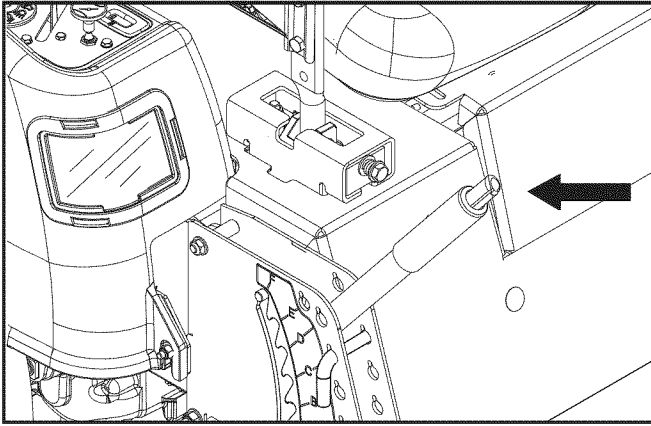

IMPORTANT INFORMATION Always raise the deck to the highest position for transport.

IMPORTANT INFORMATION To obtain an even cutting height, it is important that the air pressure in all tires is 15 psi / 103 kPa / 1 bar.

To set the desired deck cutting height, press the release button and move the lever forward to the correct cutting height on the cutting plate. The cutting height range is from 1½" (38 mm) to 4" (102 mm) in ½" (13 mm) increments. The heights are measured from the ground up to the blade tip with the engine not running.

Tracking

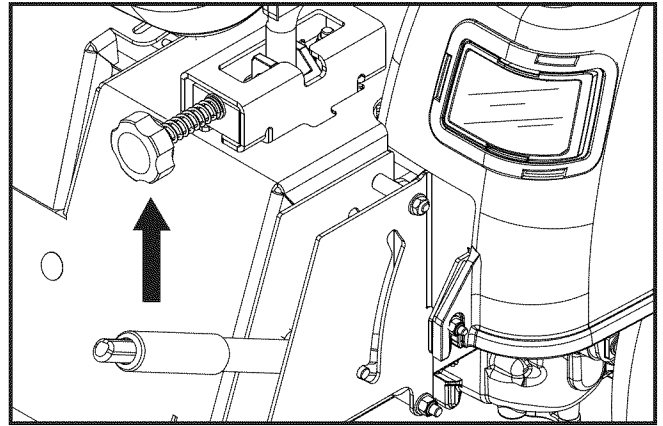

If the mower is not tracking straight, check the air pressure in both rear tires. Recommended air pressure is 15 psi (103 kPa / 1 bar) for all tires. Tracking must be checked on a flat and level concrete or blacktop surface.

Rotating the tracking knob allows fine tuning adjustments so the machine tracks straight with the steering control levers in the full forward position.

Rotate the knob counter clockwise (as viewed from the operation position) to increase the speed on the left lever. Rotate clockwise to decrease speed.

Bypass Linkages

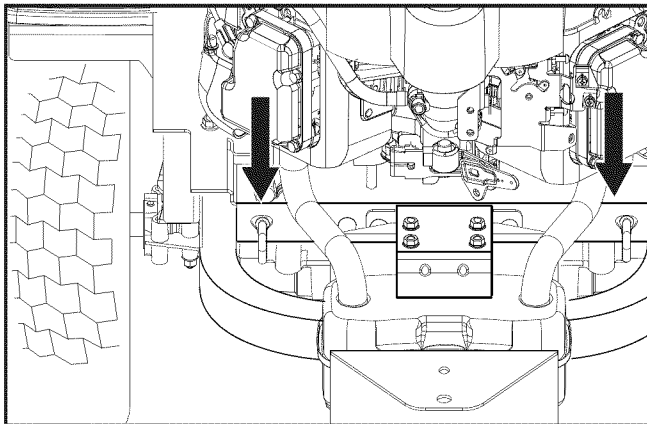

Transaxle bypass linkages must be engaged when pushing or pulling the mower. The release levers are located on each side of the rear of the unit below the rear engine plate. See **Moving Machine By Hand** in the *Operation* section.

WARNING! Bypass linkages are located close to the muffler. To prevent burns, the engine should be shut off and allowed to cool before the bypass linkage levers are handled.

CONTROLS

Fuel Tank

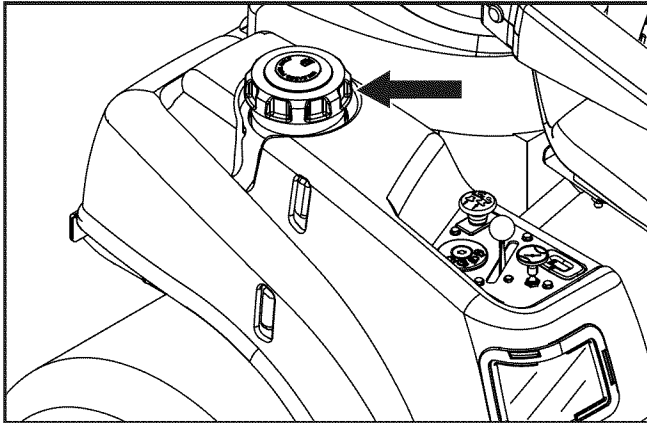

IMPORTANT INFORMATION Experience indicates that alcohol blended fuels (called gasohol, ethanol or methanol) can attract moisture which leads to separation and formation of acids during storage. Acidic gas can damage the fuel system of an engine while in storage. To avoid engine problems, the fuel system should be emptied before storage of 30 days or longer. Drain the gas tank, start the engine and let it run until the fuel lines and carburetor are empty. Use fresh fuel the next season. See **Storage** for additional information. Never use engine or carburetor cleaners in the fuel tank or permanent damage may occur.

WARNING! Gasoline is highly flammable. Observe caution and fill the tank outdoors (see the safety instruction).

WARNING! The engine and the exhaust system, become very hot during operation. Risk for burns if touched. Allow engine and exhaust system to cool before refueling.

WARNING! Fill to bottom of filler neck. Do not overfill. Wipe off any spilled oil or fuel. Do not store, spill or use gasoline near an open flame.

Read the safety instructions before refueling. The machine has one fuel tank, just behind the console. The tank capacity is 3.5 gallons (13.25 liters).

Regularly check the gas cap gasket for damage and keep the cap properly tightened.

The engine will run on a minimum of 85-octane unleaded gasoline (no oil mix). Environmentally adapted alkylate gasoline can be used. See also **Technical Data** concerning ethanol fuel. Methanol fuel is not allowed. Do not use E85 alcohol based fuel. Damage to engine and components may occur.

When operating in temperatures below 32° F. (0° C.), use fresh, clean winter grade gasoline to insure good cold weather starting.

OPERATION

Read the *Safety* section and following pages, if you are unfamiliar with the machine.

Training

Due to unique steering capabilities, zero turn mowers are far more maneuverable than typical riding mowers.

This section should be reviewed in its entirety prior to attempting to move the mower under its own power. When first operating the mower or until becoming comfortable with controls, use a reduced throttle speed and reduced ground speed. DO NOT move control levers to the furthest forward or reverse positions during initial operation.

First time users should become familiar with the mower's movement on a hard surface, such as concrete or blacktop PRIOR to attempting to operate on turf. Until the operator becomes comfortable with the mower controls and zero turning capability, overly aggressive maneuvers may damage turf.

Steering

To move forward and backward

The direction and speed of the mower's movements are effected by the movement of the control lever(s) on each side of mower. The left control lever controls the left wheel. The right control lever controls the right wheel.

First time users should push the mower (see *Manual Transport* in the *Operation* section) to an open, flat area without other people, vehicles or obstacles nearby. To move the unit under its own power, the operator must sit in the seat and start the engine (see *Before Starting* in the *Operation* section). Adjust the engine speed to idle, disengage the park brake but do not engage the blades at this time. Rotate control levers inward. As long as the control levers have not been moved forward or backwards, the mower will not move.

Slowly move both control levers forward slightly. This will allow mower to start moving forward in a straight line. Pull the control levers back to the neutral position and the mower should stop moving.

Pull back slightly on control levers, allowing the mower to move backwards. Push the control levers forward to the neutral position and mower should stop moving.

To turn to the right

While moving in a forward direction, pull the right lever back towards the neutral position while maintaining the position of the left lever, this will slow the rotation of the right wheel and cause the machine to turn in that direction.

To turn to the left

While moving in a forward direction pull the left lever back towards the neutral position while maintaining the position of the right lever, this will slow the rotation of the left wheel and cause the machine to turn in that direction.

To zero turn

While moving in a forward direction, first pull both control levers back until the mower stops or slows dramatically. Then by alternating one lever slightly to the forward position and the other in the reverse position, complete the turn.

Complete Start Ignition

NOTES: The default passcode [321] is preset at the factory. For safety and security, the passcode should be changed prior to use.

Resetting ignition system passcode

1. To initialize the ignition system, press the START/STOP (S/S) button on the ignition switch or sit on the seat. The blue indicator will blink, showing the system is operational.
2. Using the lower buttons, press and hold the (1) and (3) buttons at the same time for three seconds. The blue indicator will then be lit continuously, signalling the system is ready to accept a new code.

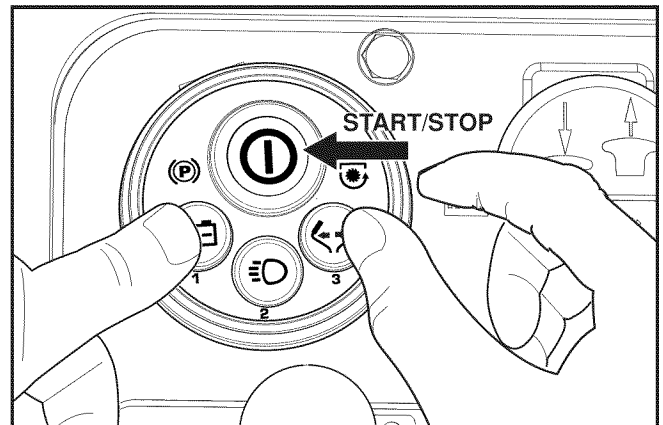

3. Using the lower buttons, enter a desired code of numbers from one to five digits and then press the S/S button. The indicator will blink green to signal the passcode has been accepted.
4. If the S/S button blinks red, the passcode reset has not been accepted. Wait for the S/S button to return to blinking blue and retry the programming, starting at Step 1.

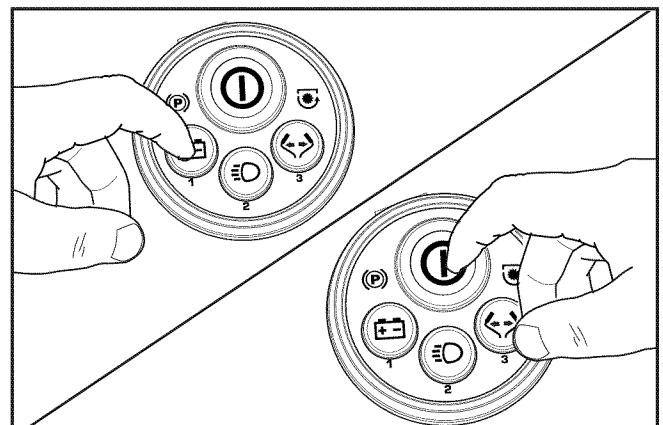

OPERATION

Before Starting

1. Read the sections on *Safety* and *Controls* before starting the machine.
2. Perform the daily maintenance before starting (see **Maintenance Schedule** in the *Maintenance* section).
3. Check that there is sufficient fuel in the fuel tank.
4. Adjust the seat to the desired position.

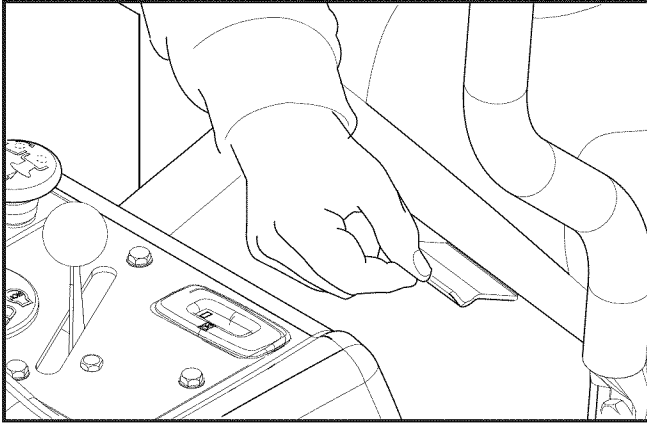

5. Set the deck cutting height by inserting the lift pin into the desired cut height.

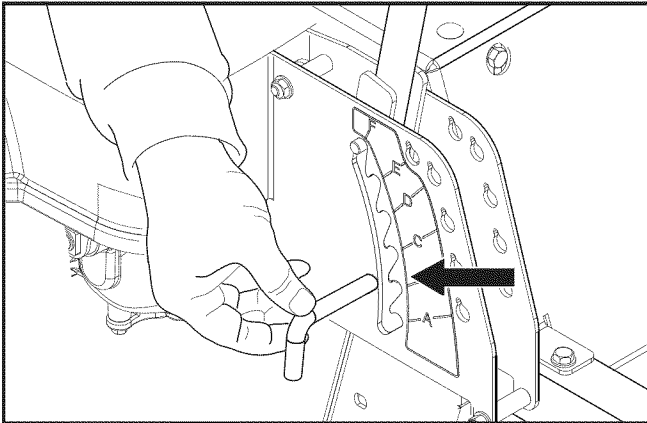

The following conditions must be fulfilled before the engine can be started:

- The blade switch must be pressed downward into the disengaged position.
- The park brake must be up into the activated position.
- Both steering controls must be in the locked (outer) neutral position.

Starting the Engine

1. Sit on the seat.
2. Raise the mower deck by pushing the release button on the top of the lifting lever. Pull the lifting lever backward to the locked (transport) position.

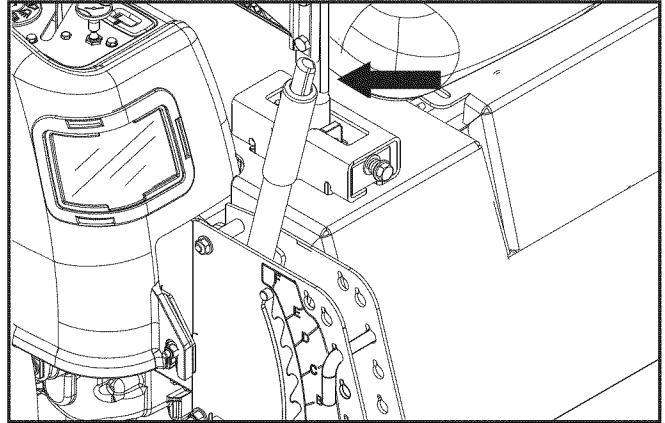

3. Activate the park brake by pushing the release button in and pulling the lever fully upwards.

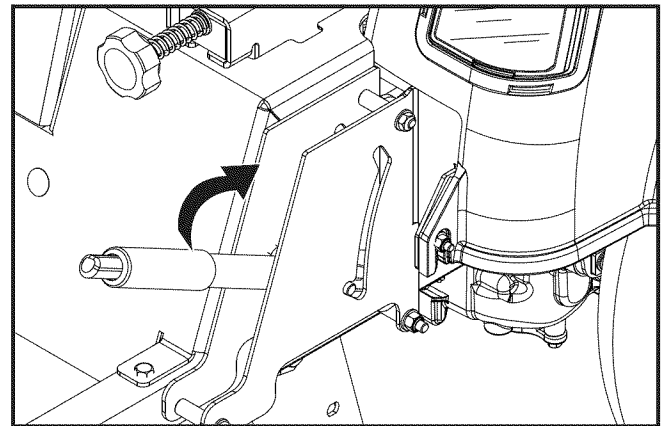

4. Disengage the mower blades by pressing the blade switch down.

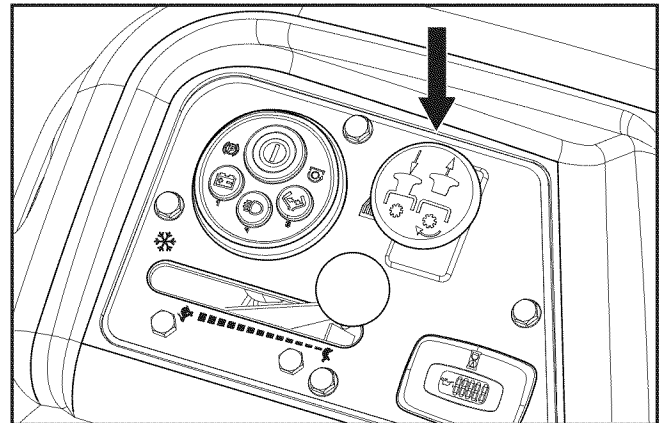

OPERATION

5. Move the steering controls outward to the locked (outer) neutral position.

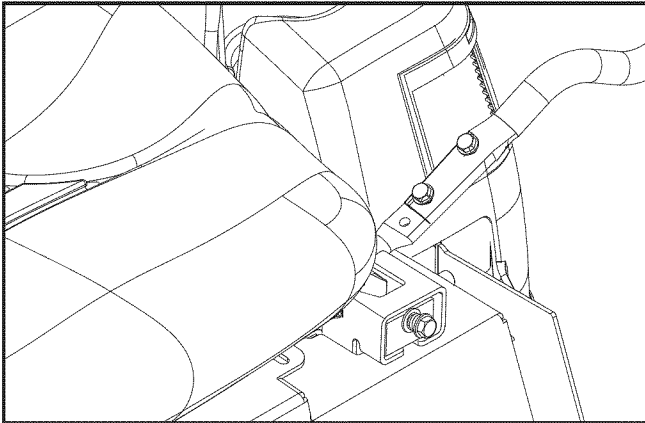

6. Move the throttle to the full position.
NOTE: There is a detent at the full throttle position to aid in setting the control.

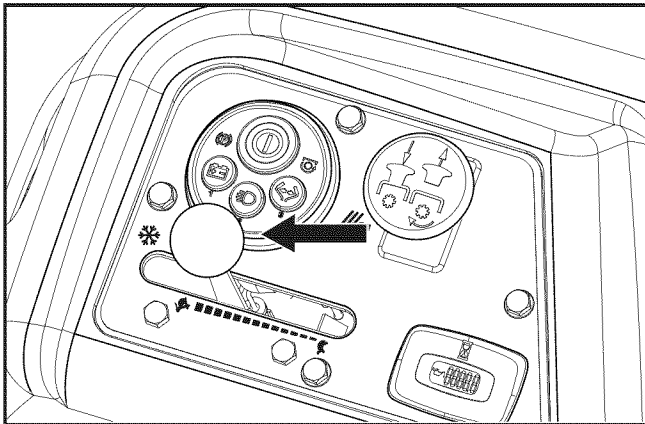

If the temperature is below 32°F, move the throttle lever up to the cold weather (snowflake) starting position.

When the engine has started, move the throttle lever back to full throttle detent and allow the engine to warm up for a short period before operating the unit. Failure to move the throttle from the cold weather starting position will result in poor engine performance, smoke and spark plug fouling.

7. Press and release the S/S button to activate the ignition switch. Check that the indicator is blinking blue.

IMPORTANT INFORMATION Either of two actions will wake up the ignition switch—either the operator sitting on the seat or pressing the S/S button.

Enter the passcode and press the S/S button. The S/S button will flash one slow green blink if the code is accepted and will change to a rapid green blink. If the S/S button has accepted the code but does not stay lit with a rapid green blink, see **Ignition System Faults** on the following page.

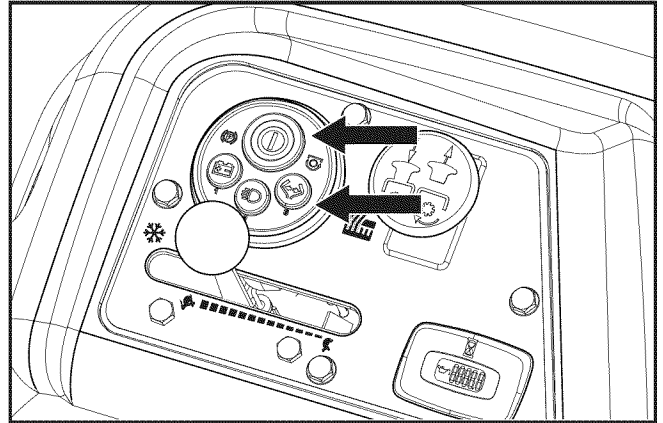

8. When the S/S button displays a rapid green blink, press and release the button once more to start the engine.

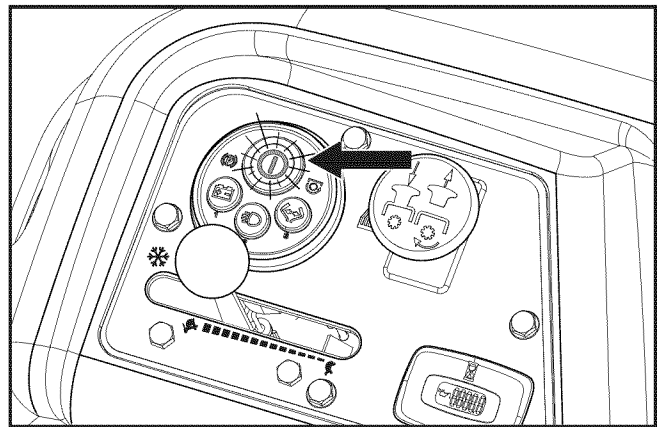

IMPORTANT INFORMATION Under normal starting conditions, use a press and release method for the ignition start/stop switch. Do not press and hold.

NOTE: For the first start after the unit has sat idle for an extended period of time, or has been refueled after being run out of gas, the engine may require an extended start attempt to reprime the fuel system. Press and hold down the S/S switch for three seconds and then release. This will prompt the engine starter to attempt starting the engine for up to ten seconds (instead of the normal five seconds), allowing time for fuel to be pulled into the engine.

OPERATION

Ignition System Faults

The Complete Start Ignition is programmed to warn when any part of the safety system is not being followed and will not allow the unit to be started until all system faults are resolved.

The park brake fault light will blink if the park brake has not been engaged.

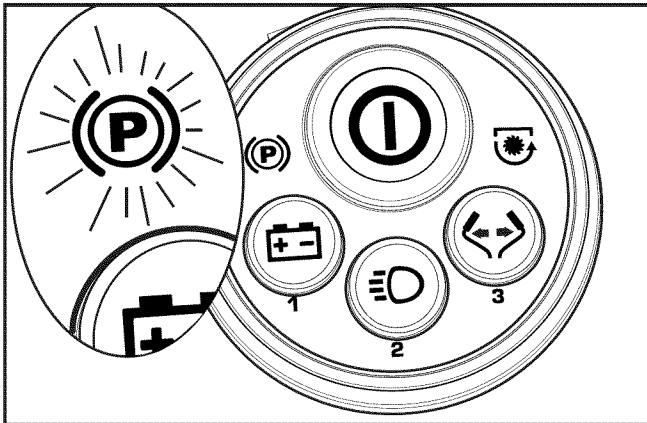

The blade switch fault light will blink if the blade control switch has not been disengaged (down position) or is disconnected.

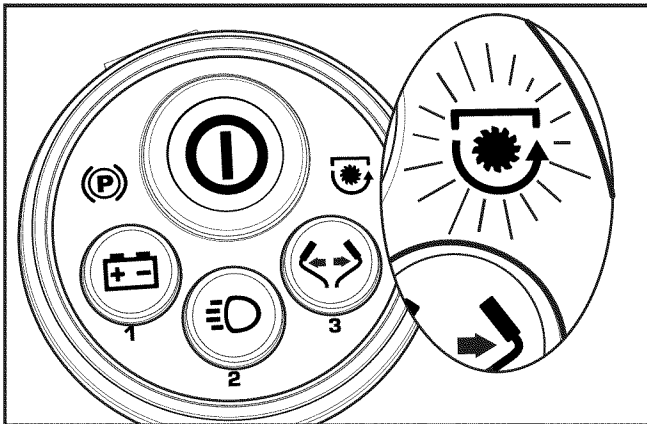

The motion control fault light will blink if the motion control levers are not in the neutral (outer) position.

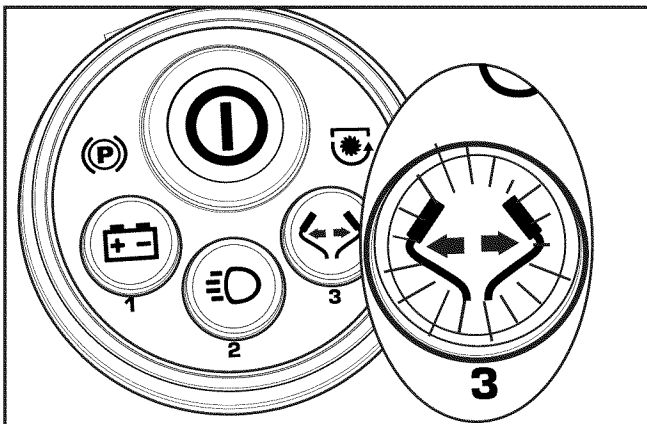

Running

1. Release the park brake by pushing the top release button in and moving the lever downward.

NOTE: The mower is equipped with an operator presence system. When the engine is running, any attempt by the operator to leave the seat without first setting the park brake will shut off the engine.

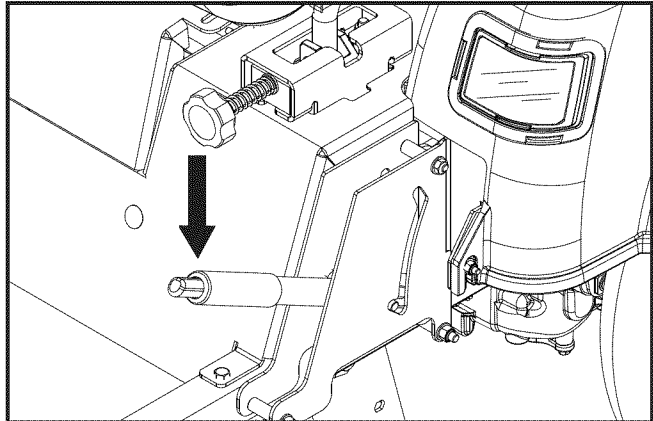

2. Move the steering controls inwards, out of the neutral position (N).
3. Push the release button on the cutting height lever and move lever to the pin, release the button.
4. Engage the mower deck by pulling up the blade switch. **USE FULL THROTTLE WHEN MOWING.**

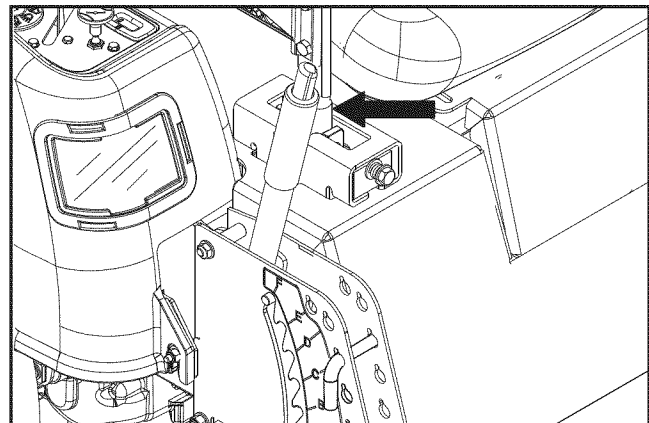

⚠ WARNING! Make sure that no one is near mower when engaging blade switch. Make sure the work area is free from objects that could be thrown by the rotating blades.

⚠ WARNING! Engine exhaust and certain vehicle components contain or emit chemicals considered to cause cancer, birth defects or other reproductive system damage. The engine exhaust contains carbon monoxide, which is a odorless, colorless, poisonous gas. Do not use the machine in enclosed spaces.

OPERATION

Stopping the Engine

1. Move the throttle to the minimum position (tortoise symbol).

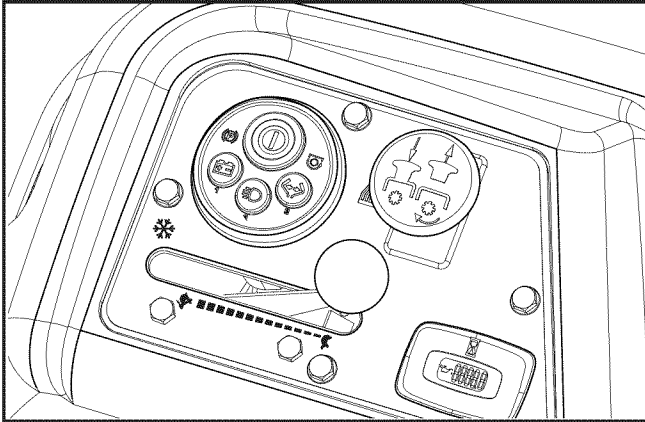

2. Move the steering controls outward.
3. Disengage the mower deck by pressing the blade switch down.
4. Raise the mower deck by pressing the release button on the lever and pulling the lever upward to the transport position.
5. When the machine is standing still, activate the park brake.
If the engine has been worked hard, allow it to idle at least 60 seconds to attain a normal operating temperature before stopping. To prevent fouling the spark plugs, avoid idling the engine for longer periods.
6. Press and release the S/S button to stop the engine. The ignition system will return to the a ready-to-start mode with a blinking green light.

The electrical system will automatically shut down thirty seconds after the operator leaves the seat. It can be deactivated immediately by pressing and holding button 1 and button 3 simultaneously for two seconds.

Unexpected Engine Stoppage

If the engine stops unexpectedly and all of the Complete Start indicator lights flash simultaneously, it is an indication of a nonsafety related shutdown (example, running out of gas). The system will reset after a few moments and return to a prestart status. The reason for the shutdown must be identified and corrected prior to attempting a restart (example, refuel the unit).

Mowing Tips

! WARNING! Clear the lawn of stones and other objects that can be thrown out by the blades.

- Observe and flag rocks and other fixed objects to avoid collisions.
- Begin with a high cutting height and reduce it until the desired mowing result is attained. The average lawn should be cut to 64 mm during the cool season and over 76 mm during the hot months. For healthier and better looking lawns, mow often after moderate growth. For best cutting performance, grass over 15 cm in height should be mowed twice. Make the first cut relatively high, the second to the desired height.
- The mowing result will be best with a high engine speed (blades rotate rapidly) and low speed (rider moves slowly). If the grass is not too long and dense, the driving speed can be increased without negatively affecting the mowing result.
- The finest lawns are obtained by mowing often. The lawn becomes more even and the grass clippings more evenly distributed over the mown area. The total time taken is not increased as a higher operating speed can be used without poor mowing results.

! WARNING! Never drive the rider on terrain that slopes more than 10 degrees. Mow slopes up and down, never side to side. Avoid sudden directional changes.

- Avoid mowing wet lawns. The mowing result is poorer because the wheels sink into the soft lawn, clumps build, and grass clippings fasten under the cowlings.
- Hose the mower deck underside with water after each use. When cleaning, the mower deck shall be raised into the transport position. Make sure the mower is cooled and the engine is off.
- Use compressed air to clean top surface of the deck. Avoid flooding water on top surface, engine and electrical components.
- When the mulching kit is used, it is important that the mowing interval is frequent.

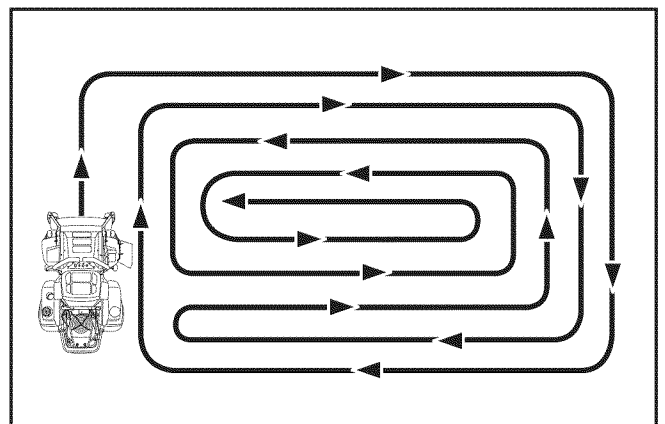

OPERATION

Operating On Hills

Read the Safety Instructions **Driving on Slopes** in the *Safety* section.

- The slowest speed possible should be used before starting up or down hills.
- Avoid stopping or changing speed on hills.
- If stopping is absolutely necessary, pull steering controls into the neutral position and push to the outside of the unit. Engage the park brake.
- To restart movement, release the park brake.
- Pull the control levers back to the center of the mower and press forward to regain forward motion.
- Make all turns slowly.

WARNING! Do not drive up or down hills with slopes greater than 10 degrees. Do not drive across slopes.

Headlights

Use Button 2 to turn on/off the headlights. When the engine is in start mode, press the button to turn the headlights on. A blinking Button 2 light signals that one or both headlights are not working.

The headlights can also be used when the ignition switch is not activated or the unit is not running. Press Button 2 and the headlights will stay lit for one minute.

For a longer headlight mode, press and hold the button for five seconds. The headlights will flash twice to acknowledge and will stay on for five minutes.

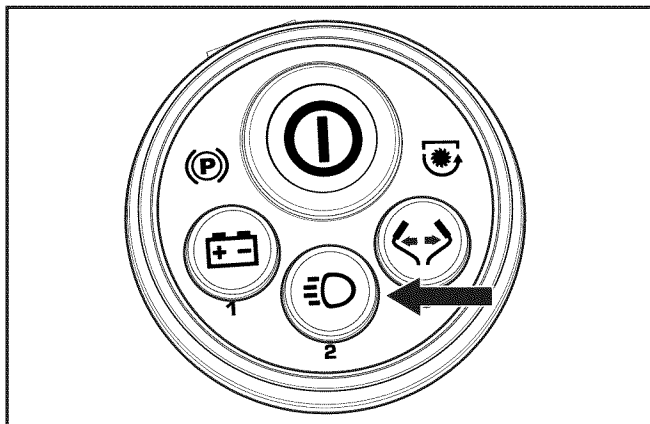

Weak Battery

If the battery is too weak to start the engine, it should be recharged. (See **Battery** in the *Maintenance* section.)

If jumper cables are used for emergency starting, follow this procedure:

Jumper Cable Use

7. Connect each end of the RED cable to the POSITIVE (+) terminal on each battery, taking care not to short against chassis.
8. Connect one end of the BLACK cable to the NEGATIVE (-) terminal of the fully charged battery.
9. Connect the other end of the BLACK cable to a good CHASSIS GROUND on the mower with the discharged battery, away from the fuel tank and battery.

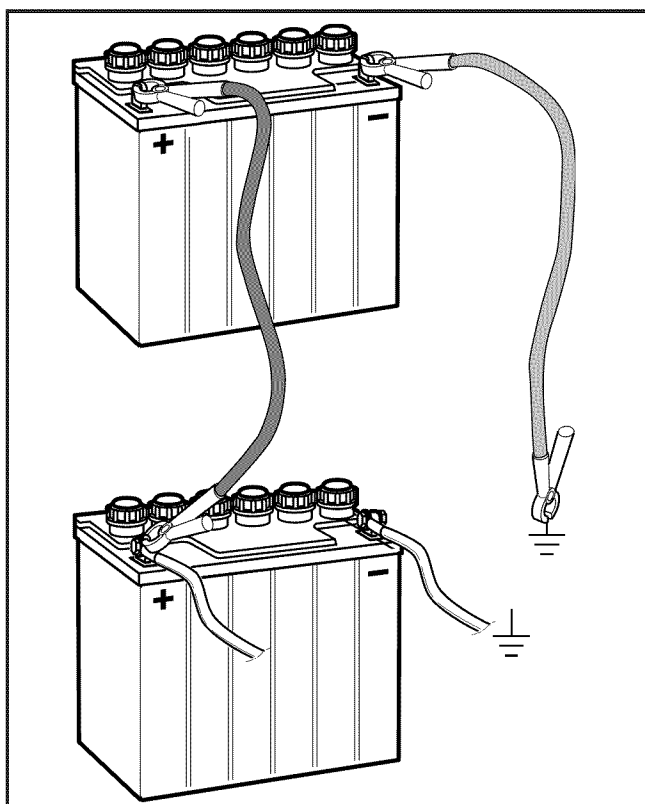

To remove cables, reverse order

1. Remove BLACK cable first from chassis and then from the fully charged battery.
2. Remove RED cable last from both batteries.

CAUTION! Lead-acid batteries generate explosive gases. Keep sparks, flame and smoking materials away from batteries. Always wear eye protection when around batteries.

IMPORTANT INFORMATION The mower is equipped with a 12-volt negative grounded system. The other vehicle must also be a 12-volt negative grounded system. Do not use your mower to start other vehicles.

OPERATION

Battery Voltage Light

A battery voltage light can indicate that voltage is below the normal operating power.

If the battery is low when a start attempt is made, the battery indicator button will light up. This is an indication the battery should be charged. It will not prevent additional start attempts as long as remaining charge is capable of cranking the engine. The button can also indicate a charge system failure if it lights up during operation.

Checking Battery Charge System

When unit is in ready mode (blinking green), press and hold the battery button for three seconds. The S/S button indicator will show red (*battery charge level is low*), multi-colored (*battery charge is marginal*) or green (*battery level is good*) until the battery button is pressed again or is allowed to reset after ten seconds.

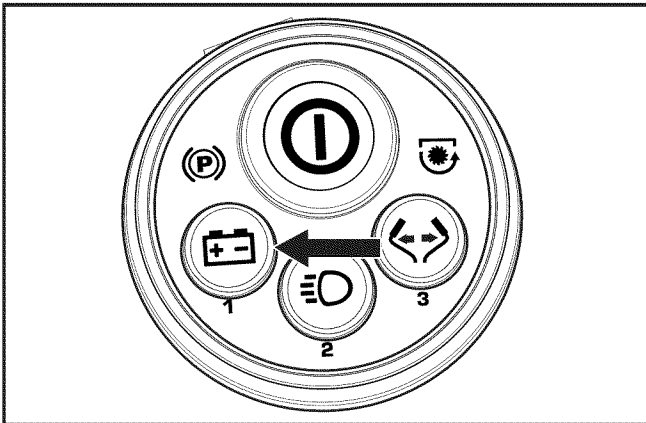

Moving Machine By Hand

When pushing or pulling the mower, engage the EZT bypass linkages. The EZT bypass linkages are located on the rear of the frame, below the rear engine guard.

1. Raise the deck into the highest cutting position.
2. Engage the park brake.
3. Pull the EZT bypass linkages up and out of the keyhole slots. Release the levers with the head outside the frame and held in the bypass position.
4. To reengage the EZT's to drive, reverse the above procedure.

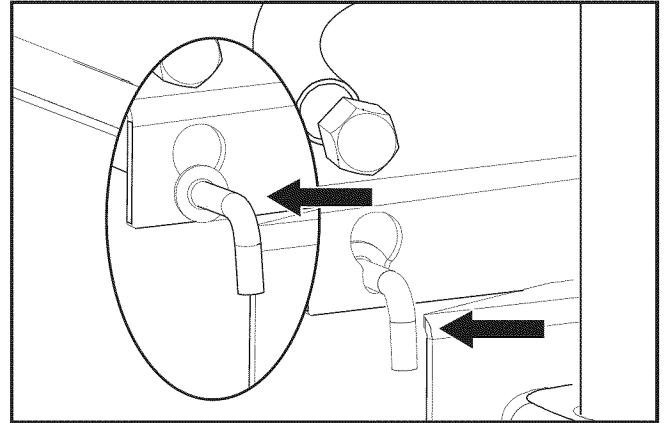

Load the machine into truck or trailer by driving slowly up the ramps. **DO NOT LIFT!** The machine is not intended to be lifted by hand.

WARNING! Bypass linkages are located close to the muffler. To prevent burns, the engine should be shut off and allowed to cool before the bypass linkage levers are handled.

WARNING! Make no adjustments without:

- the engine stopped,
- the ignition key removed,
- the park brake activated

WARNING! Use extreme caution when loading the machine into a truck or trailer using ramps. There is the possibility of serious injury or death if the machine falls off the ramps.

MAINTENANCE

Maintenance Schedule

The following is a list of maintenance procedures that must be performed on the machine. For those points not described in this manual, visit an authorized service workshop. An annual service carried out by a Sears Service Center or authorized

service workshop is recommended to maintain your machine in the best possible condition and to ensure safe operation.

Read **General Maintenance** in the **Safety** section.

MAINTENANCE	Daily		At least once each year	Maintenance interval in hours			
	Before	After		25	50	100	300
Check the park brake	●						
Check the engine's oil level (every refueling)	■						
Check the safety system	●						
Check for fuel and oil leakages	◆						
Check/clean the engine's cooling air intake		■					
Check the mower deck		●					
Check for loose hardware (screws, nuts)		●					
Clean under the mower deck		●					
Start the engine and blades, listen for unusual sounds		◆					
Check for damage		◆					
Thoroughly clean around the engine		◆					
Clean around belts, belt pulleys		◆					
Check the tire pressures				●			
Check battery connections				●			
Sharpen ³⁾ / Replace mower blades				●			
Clean the engine's cooling air intake ²⁾			■	■			
Clean the foam air cleaner prefilter ²⁾			■	■			
Clean the paper air cleaner filter cartridge ²⁾			■				
Check/adjust the park brake			◆		◆		
Inspect muffler/spark arrestor			◆		◆		

¹⁾ First change after 8-10 hours. When operating with a heavy load or at high ambient temperatures, replace every 50 hours.

²⁾ In dusty conditions, cleaning and replacement are required more often.

³⁾ Performed by authorized service workshop.

● = Described in this manual

◆ = Not described in this manual

■ = Refer to the engine manufacturer's manual

MAINTENANCE

MAINTENANCE	Daily		At least once each year	Maintenance interval in hours			
	Before	After		25	50	100	300
Check/adjust throttle cable						■	
Check the condition of belts, belt pulleys			●			●	
Change the engine oil ¹⁾			■		■		
Replace the engine oil filter			■			■	
Clean/replace the spark plugs			■			■	
Replace the fuel filter			●			●	
Replace paper air filter ²⁾			■			■	
Check the caster wheels (every 200 hours)			●			●	
Replace the air cleaner's foam pre-filter ²⁾			■				
Check/adjust the mower deck			●				●
Check the engine valve clearance ³⁾			◆				◆
Perform the 300-hour service ³⁾			◆				◆

¹⁾ First change after 8-10 hours. When operating with a heavy load or at high ambient temperatures, replace every 50 hours.

²⁾ In dusty conditions, cleaning and replacement are required more often.

³⁾ Performed by authorized service workshop.

● = Described in this manual

◆ = Not described in this manual

■ = Refer to the engine manufacturer's manual



WARNING! Before performing any service or adjustment checklist

- Engage the park brake.
- Place the Blade-switch in the disengaged position.
- Turn the ignition switch to OFF position and remove the key.
- Make sure the blades and all moving parts have completely stopped.



WARNING!

Escaping hydraulic oil under pressure can have sufficient force to penetrate the skin, causing serious injury. If injured by escaping fluid, see a doctor at once. Serious infection or reaction can develop if proper medical treatment is not administered immediately.

MAINTENANCE

Battery

Your mower is equipped with a maintenance free battery and does not need servicing. However, periodic charging of the battery with an automotive type battery charger will extend its life.

- Keep battery and terminals clean.
- Keep battery bolts tight.
- See chart for charging times.



CAUTION! Always wear eye protection when around batteries.

Cleaning battery and terminals

Corrosion and dirt on the battery and terminals can cause the battery to lose power.

1. Open the terminal access doors.
2. Disconnect BLACK battery cable first, then the RED battery cable and remove the battery from the machine.
3. Rinse the battery with plain water and dry.
4. Clean terminals and battery cable ends with wire brush until shiny.
5. Coat terminals with grease or petroleum jelly.
6. Reinstall battery.

Replacing battery

1. Lift seat and rotate forward.
2. Using two ½" wrenches disconnect BLACK battery cable then RED battery cable.
3. Position deck to lowest setting.
4. Front underside of frame, remove the nuts that secure the battery hold-down.

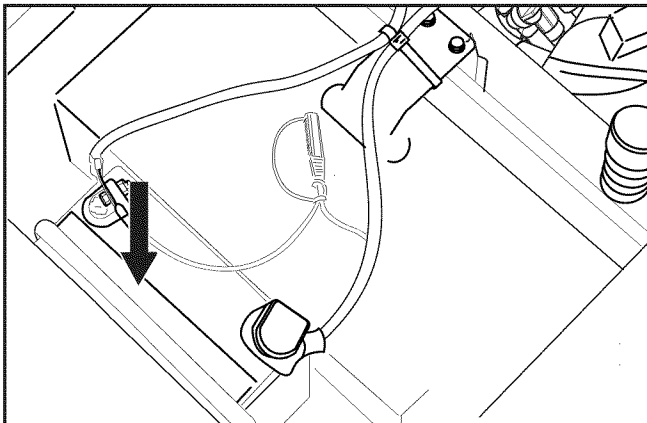

5. Carefully remove the battery from the mower.
6. Install new battery with terminals in the same position as the old battery.
7. Reinstall battery hold-down and secure with nuts removed in Step 4.
8. Reconnect RED battery cable to positive (+) battery terminal with bolt and hex nut.

STANDARD BATTERY	STATE OF CHARGE	APPROXIMATE BATTERY CHARGING TIME* TO FULL CHARGE AT 80°F / 27°C			
		Maximum Rate at:			
		50 Amps	30 Amps	20 Amps	10 Amps
12.6V	100%	- FULL CHARGE -			
12.4V	75%	20 min.	35 min.	48 min.	90 min.
12.2V	50%	45 min.	75 min.	95 min.	180 min.
12.0V	25%	65 min.	115 min.	145 min.	280 min.
11.8V	0%	85 min.	150 min.	195 min.	370 min.

*Charging time depends on battery capacity, condition, age, temperature and efficiency of charger

9. Connect BLACK grounding cable to negative (-) battery terminal with remaining hex bolt and hex nut
10. Replace terminal boot cover.
11. Lower seat



WARNING! Do not short battery terminals by allowing a wrench or any other object to contact both terminals at the same time. Before connecting battery, remove metal bracelets, wristwatch bands, rings, etc. Positive terminal must be connected first to prevent sparks from accidental grounding.

IMPORTANT INFORMATION Do not attempt to open or remove caps or covers. Adding or checking level of electrolyte is not necessary.

Always use two wrenches for the terminal screws.

MAINTENANCE

Safety System

The machine is equipped with a safety system that prevents starting or driving under the following conditions.

The engine can only be started when:

- The mower deck is disengaged.
- The steering controls are in the outer, locked neutral position.
- The park brake is on.

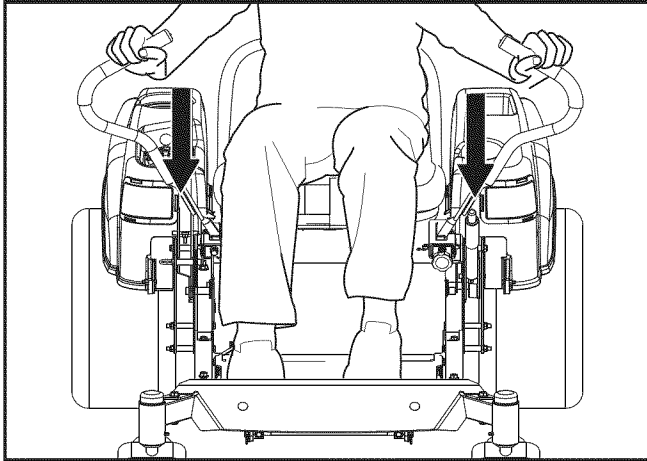

Make daily inspections to ensure that the safety system works by attempting to start the engine when one of the conditions is not met. Change the conditions and try again.

If the machine starts when one of these conditions is not met, turn the machine off and repair the safety system before using the machine again.

Make sure the engine stops when the park brake is not engaged and the operator leaves the seated position.

Check that the engine stops if the mower blades are engaged and the driver temporarily moves off the drivers seat.

IMPORTANT INFORMATION To be able to drive, the driver must sit in the seat and release the park brake before the steering controls can be moved into the neutral position, otherwise the engine will stop.

Park Brake

Visually check that no damage is found on the lever, cables, or switch belonging to the park brake. Perform a standstill test and check that there is sufficient braking action.

To adjust the park brake, contact a Sears Service Center or authorized service workshop.

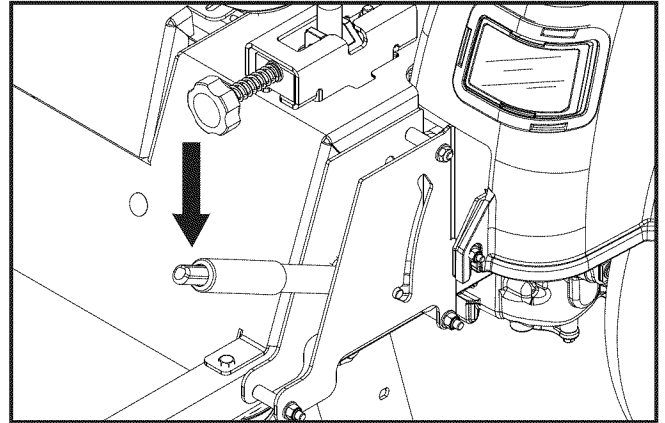

IMPORTANT INFORMATION The machine must be absolutely standing still when applying the park brake.

WARNING! Faulty adjustment will result in reduced braking ability and can cause an accident.

Tire Pressures

All tires should be at 15 psi / 103 kPa / 1 bar.

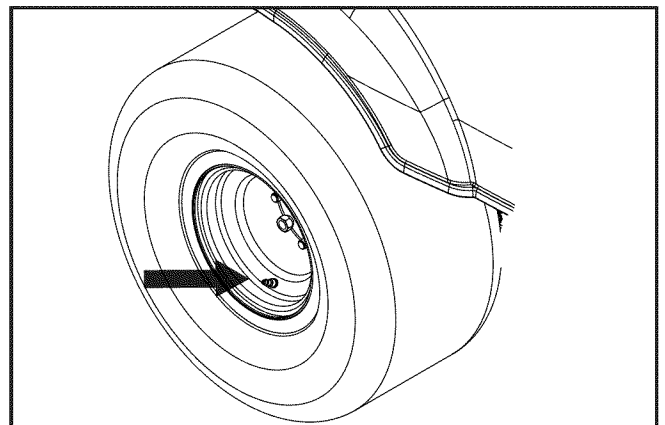

IMPORTANT INFORMATION DO NOT add any type of tire liner or foam fill material to the tires. Excessive loads created by foam filled tires will cause premature failures. Only use O.E.M. specified tires.

MAINTENANCE

Caster Wheels

Check every 200 hours. Check that wheels rotate freely. If wheels do not rotate freely take the unit to your dealer for service.

Foam filled tires or solid tires will void the warranty.

Removal and installation

Remove nut and caster bolt. Pull the wheel out of the yoke and take care of the spacers. Install in reverse order. Tighten caster bolt.

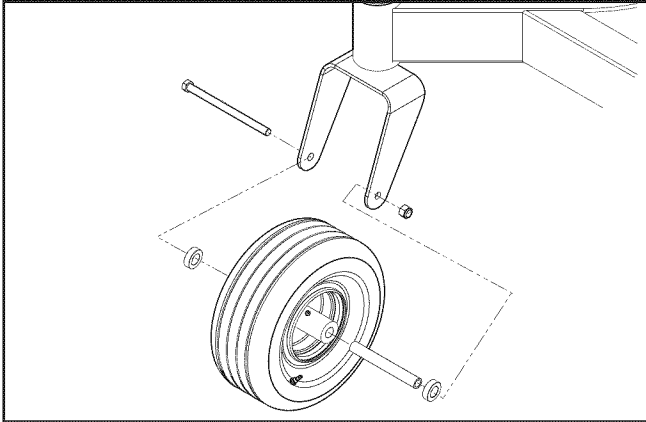

Anti-scalp Rollers

Anti-scalp rollers are properly adjusted when they are just slightly off of the ground when the deck is at the desired cutting height in the operating position. Anti-scalp rollers then keep the deck in the proper position to help prevent scalping in most terrain conditions.

Anti-scalp rollers can be set in four positions. The rollers should be approximately 6,5 mm from ground. Do not adjust the rollers to support the deck.

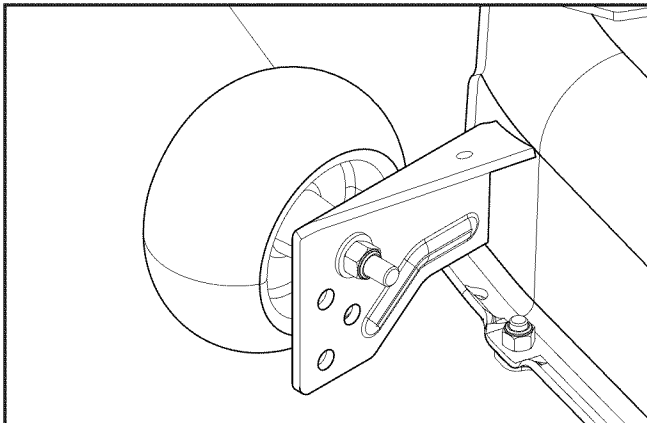

IMPORTANT INFORMATION Adjust anti-scalp rollers with the mower on a flat level surface. To avoid deck damage, the anti-scalp rollers must not be adjusted to support the deck.

V-belts

Check every 100 hours of operation. Check for severe cracking and large nicks.

NOTE: The belt will show some small cracks in normal operation.

The belts are not adjustable. Replace belts if they begin to slip from wear.

Deck Belt Removal

1. Park on a level surface. Apply park brake.
2. Lower the deck into the lowest cutting position.
3. Remove bolts from belt shields and remove shields.
4. Remove any dirt or grass that may have accumulated around the cutter housings and entire deck surface.
5. Loosen the nut securing the belt guide. Note the position of the belt guide for reinstallation.

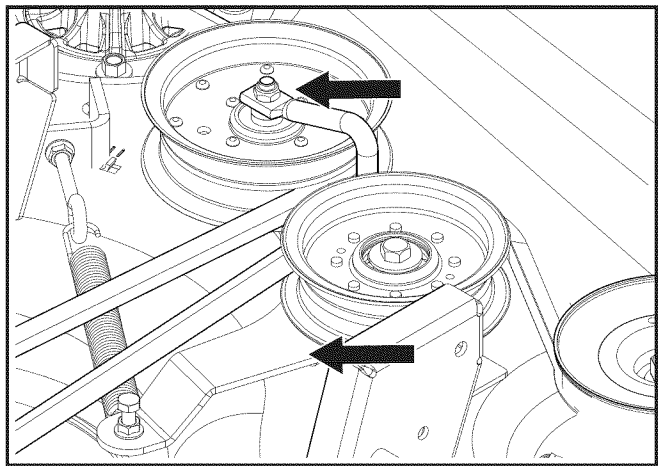

6. Push inward on the idler arm to release the tension on the belt.
7. Carefully slip the belt over the top of the cutter housing pulleys and remove belt from the deck.

Deck Belt Installation

NOTE: For ease in installing the deck belt, refer to the routing decal on the top of the deck.

1. Wrap the deck belt around the electric clutch pulley that is located on the engine shaft.
2. Route the belt forward and up onto the deck.
3. Place belt around spring loaded idler pulley.
4. Wrap the belt around the stationary idler pulley and around the mandrel housings.
5. Push inward on the idler arm and carefully route belt over stationary idler pulley. Once the belt is properly routed, slowly release the idler arm to tension belt.
6. Double check belt routing to make sure it **matches the decal affixed to the deck**, and the belt does not have any twist. Correct if needed.
7. Tighten the belt guide and replace belt shields on both mandrel housings and secure with fasteners.

NOTE: The belt guide should be perpendicular to the belt when installation is complete.

MAINTENANCE

Adjusting the Mower Deck

Leveling deck

Adjust the deck while the mower is on a level surface. Make sure the tires are inflated to the correct pressure. See **Technical Data** / Transmission. If tires are under or over inflated, the deck cannot be properly adjusted. Raise the deck to the highest (transport) position.

The deck should be adjusted slightly higher in the rear.

NOTE: To insure accuracy of leveling procedure, mower deck drive belt must be installed prior to leveling deck.

1. Wear heavy gloves. Turn each outer blade tip to align side to side.

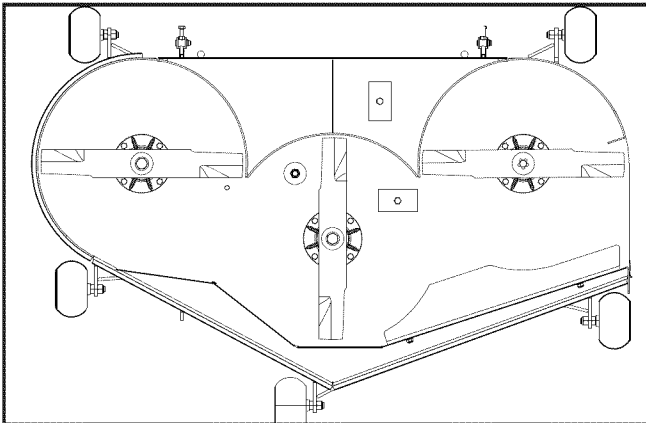

2. Measure from the floor surface up to the bottom of the blade tip on the discharge side of the mower deck. Record this measurement.
3. Move to the opposite side, check that the measurement is the same. If adjustment is required—with a $\frac{3}{4}$ " or adjustable wrench, turn the lift link adjustment nuts on either side counter clockwise to lower or clockwise to raise. Adjust until both side-to-side measurements are equal.

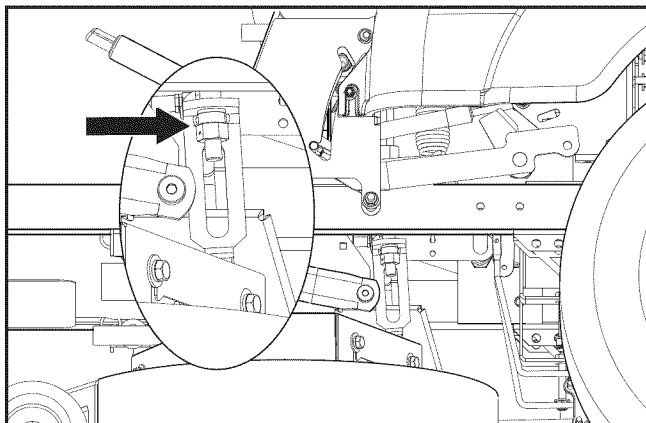

4. Turn either blade to align with the deck front-to-rear. If the front blade tip does not measure $\frac{1}{8}$ " to $\frac{1}{2}$ " higher in the rear, follow the front adjustment instructions that follow.
5. With a $\frac{5}{8}$ " or adjustable wrench, turn the nuts on the front suspension linkage. Clockwise raises the front of the mower, counterclockwise will lower the front. Adjust nuts until rear of mower deck is positioned level to $\frac{1}{8}$ " higher in the rear than the side-to-side measurement.

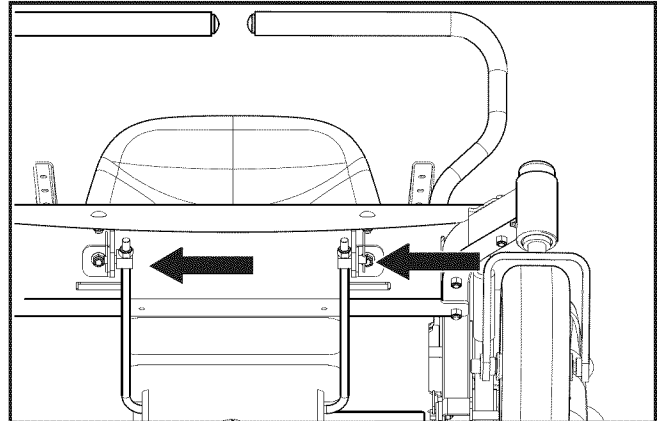

NOTE: This will place the mower deck in a standard measurement position. Depending on the type of grass being mowed or environmental conditions, additional adjustments may be required to achieve the desired cut.

MAINTENANCE

Cutting Blades

For the best mowing results, it is important that blades are well sharpened and not damaged.

Replace blades that have been bent or cracked when hitting obstacles.

Let the service workshop decide whether a blade with large nicks can be repaired/ground or must be replaced. Balance the blades after sharpening. Check the blade mounts.



CAUTION! Blades are sharp. Protect your hands with gloves and/or wrap blades with a heavy cloth when handling.

The sharpening of blades should be carried out by a Sears Service Center or authorized service workshop.

Blade replacement

1. Remove blade bolt by turning counterclockwise.
2. Install new or resharpened blade with stamped **GRASS SIDE** facing towards ground/grass (down) or **THIS SIDE UP** facing deck and cutter housing.
3. Seat the blade's opening firmly onto the cutter housing.
4. Tighten blade bolt securely.
5. Torque blade bolt to 45-60 ft/lbs (60-81 Nm).

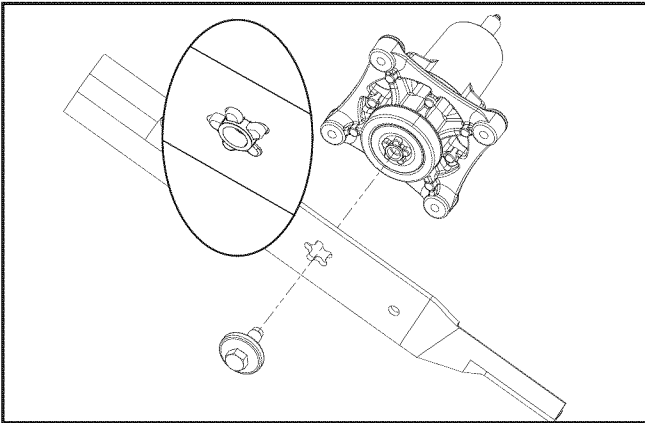

IMPORTANT INFORMATION Special blade bolt is heat treated. Replace with an original replacement bolt if required. Do not use lower grade hardware than specified.

Cleaning

Regular cleaning, especially under the mower deck, will increase the machine's life-span. Make it a habit to clean the machine directly after use (after it is cooled), before the debris sticks.

Do not spray water on the top of the mower deck. Use compressed air to clean the top side of mower deck. Regularly clean the underside of the deck with normal water pressure. Do not use a high pressure washer or steam cleaner. Avoid spraying engine and electrical components with water.

For models fitted with a cleanout port, attach the quick connect (from the accessory packet) to any garden hose. After mowing, snap the hose to the cleanout port and turn on water supply.

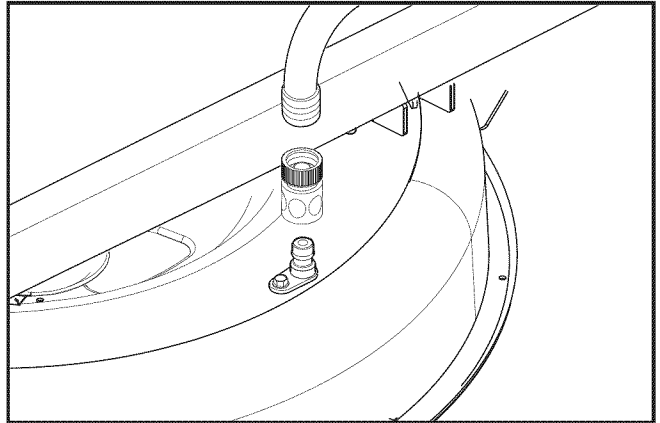

Restart the mower and engage the blades to use the spinning action to wash away debris. Make sure the hose is away from the mower blades.

Do not rinse hot surfaces with cold water. Let unit cool before washing.



CAUTION! Use protective glasses when cleaning and washing.

IMPORTANT INFORMATION Make sure no children are in the area when using the cleanout port.

Hardware

Check daily. Inspect the entire machine for loose or missing hardware.

LUBRICATION

12/12	1/52	1/365		25h	50h	100h	200h	300h
				← (2x)				
				← (2x)				
				←				
				← (2x)				
								▼
								🗑️
								👁️

12/12 Every year	Lubricate with grease gun	
1/52 Every Week	Filter change	
1/365 Every day	Oil change	
	Level check	

General

Remove the ignition key to prevent unintentional movements during lubrication.

When lubricating with an oil can, it must be filled with engine oil.

When lubricating with grease, unless otherwise stated, use a high grade molybdenum disulphide grease.

For daily use, the machine should be lubricated twice weekly.

Wipe away excess grease after lubrication.

It is important to avoid getting lubricant on the belts or the drive surfaces on the belt pulleys. Should this happen, attempt to clean them with spirits. If the belt continues to slip after cleaning, it must be replaced. Gasoline or other petroleum products must not be used to clean belts.

IMPORTANT INFORMATION Use minimal lubrication and remove excess lubricant so that it does not come into contact with belts or belt pulley drive surfaces.

Transmission

The transmission is maintenance free with no need for level checks or oil changes. If a leak occurs, replace the unit or contact a Sears Service Center or authorized service workshop.

Wheel and Deck Zerk

Use only good quality bearing grease.

Grease from well-known brand names (petrochemical companies, etc.) usually maintains a good quality.

Front Wheel Mount

Lubricate 3-4 strokes with a grease gun on each set of wheel bearings.

Front Wheel Bearings

Lubricate 3-4 strokes with a grease gun on each set of wheel bearings.

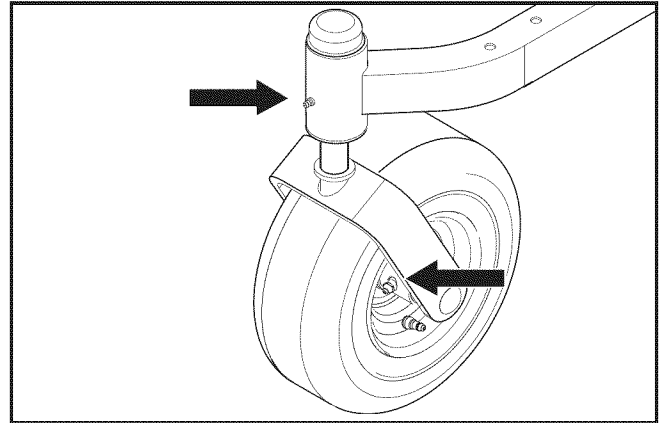

Deck Spindles

Lower the cutting deck completely.

Lubricate with a grease gun through the access openings in the belt shields, 2-3 strokes per spindle.

If a grease gun without rubber hose is used, the foot plate must be removed to access the center spindle.

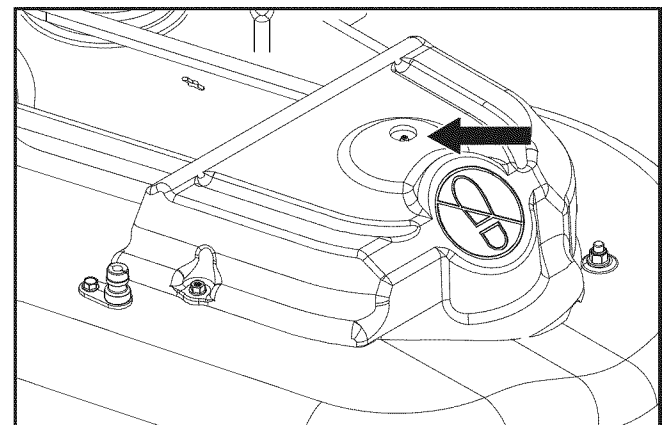

TROUBLESHOOTING

Problem / Cause

Engine will not start

- Blade switch is engaged
- Steering controls are not locked in the neutral position
- Park brake is not activated
- Battery is dead
- Contamination in the carburetor or fuel line
- Fuel supply is closed or the shutoff valve for the fuel tank is in the wrong position
- Clogged fuel filter or fuel line
- Ignition system faulty

Starter does not turn the engine over

- Battery is dead
- Poor contact of the battery terminal cable connections
- Blown fuse
- Fault in the starter safety circuit. See **Safety System** in the *Maintenance* Section

Engine runs rough

- Faulty carburetor
- Choke control is pulled out with a warm engine
- Clogged fuel filter or jet
- Throttle lever in the Cold Weather starting position
- Clogged ventilation valve on the fuel cap
- Fuel tank nearly empty
- Fouled spark plugs
- Rich fuel mixture or fuel-air mixture.
- Wrong fuel type
- Water in fuel
- Clogged air filter

Engine seems weak

- Clogged air filter
- Fouled spark plugs
- Carburetor incorrectly adjusted
- Air trapped in hydraulic system

Machine vibrates

- Blades are loose
- Blades are incorrectly balanced
- Engine is loose

Engine overheats

- Clogged air intake or cooling fins
- Engine overloaded
- Poor ventilation around engine
- Defective engine speed regulator
- Too little or no oil in the engine
- Contamination in the carburetor or fuel line.
- Fouled spark plugs

Battery not charging

- Poor contact of the battery terminal cable connections
- Charging lead is disconnected

Machine moves slowly, unevenly, or not at all

- Park brake on
- Bypass valve on pump open
- Drive belt for the transmission slack or has come off
- Air trapped in hydraulic system

Mower deck not engaging

- Drive belt for the mower deck has come loose
- Contact for the electromagnetic coupling has loosened
- Blade switch is faulty or has come loose from cable contact
- Blown fuse

Transaxle leaks oil

- Damaged seals, housing, or gaskets
- Air trapped in hydraulic system

Uneven mowing results

- Different air pressure in tires on the left and right sides.
- Bent blades
- Suspending for the mower deck is uneven
- Blades are dull
- Driving speed too high
- Grass is too long
- Grass collected under the mower deck

STORAGE

Winter Storage

The machine should be readied for storage at the end of the mowing season or if it will not be in use for more than 30 days. Fuel allowed to stand for long periods of time (30 days or more) can leave sticky residues that can plug the carburetor and disrupt engine function.

Fuel stabilizers are an acceptable option as regards to the sticky residues that can occur during storage.

Add stabilizer to the fuel in the tank or in the storage container. Always use the mixing ratios specified by the manufacturer of the stabilizer. Run the engine for at least 10 minutes after adding the stabilizer so that it reaches the carburetor. Do not empty the fuel tank and the carburetor if you have added stabilizer.



WARNING! Never store an engine with fuel in the tank indoors or in poorly ventilated spaces where fuel vapor can come in contact with open flames, sparks, or a pilot light such as in a boiler, hot water tank, clothes dryer, etc. Handle the fuel with care. It is very flammable and can cause serious personal injury and property damage. Drain the fuel into an approved container outdoors and store far away from open flame or sources of ignition. Never use gasoline for cleaning. Use a degreaser and warm water instead.

To ready the machine for storage:

1. Thoroughly clean the machine, especially under the mower deck. Touch up damage to the paint and spray a thin layer of oil on the underside of the mower deck to avoid corrosion.
2. Inspect the machine for worn or damaged parts and tighten any nuts or screws that may have become loose.
3. Change the engine oil; dispose of properly.
4. Empty the fuel tanks or add a fuel stabilizer. Start the engine and allow it to run until the carburetor is drained of fuel or the stabilizer has reached the carburetor.
5. Remove the spark plug and pour about a tablespoon of engine oil into the cylinder. Turn over the engine so that the oil is evenly distributed and then refit the spark plug.
6. Lubricate all grease zerks, joints, and axles.
7. Remove the battery. Clean, charge, and store the battery in a cool place, but protect it from direct cold.
8. Store the machine in a clean, dry place and cover it for extra protection.

Service

When ordering spare parts, please specify the purchase year, model, type, and serial number.

Always use genuine Craftsman spare parts.

An annual check-up at a Sears Service Center or authorized service workshop is a good way to ensure that your machine performs its best the following season.

SCHEMATIC

COMPLETE SWITCH IGNITION

- DO NOT OPEN
- SENSITIVE ELECTRONIC COMPONENTS INSIDE
- PERMANENT DAMAGE CAN RESULT IF PROPER DIAGNOSTIC PROCEDURES ARE NOT FOLLOWED.
- CONTACT DEALER OR AUTHORIZED SERVICE CENTER FOR REPAIR.

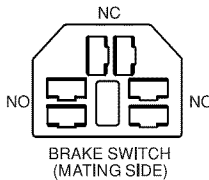
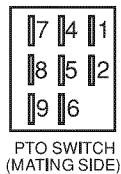
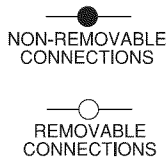
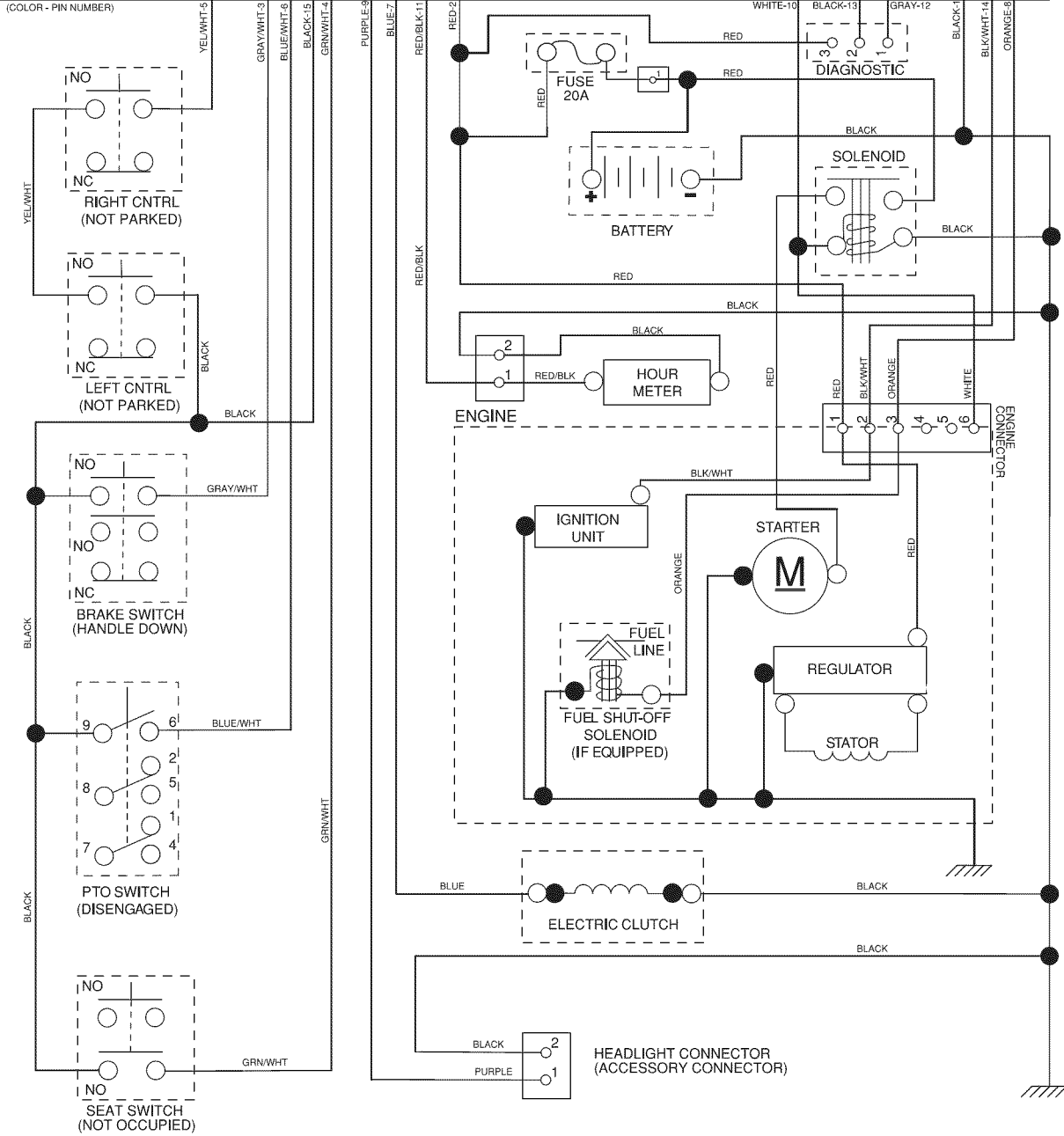

NOTE: IF WIRING INSULATED CLIPS WERE REMOVED FOR SERVICING, THEY SHOULD BE REINSTALLED TO PROPERLY SECURE WIRING

TECHNICAL DATA

Engine		Frame	
Manufacturer	Briggs & Stratton	Cutting Width	54" / 137 cm
Type	Endurance	Cutting Height	1.5" - 4" / 3,8 - 10.2 cm
Power	24 hp ¹⁾	Uncut Circle	0
Lubrication	Pressure with oil filter	Number of Blades	3
Fuel	Min 87 octane unleaded (Max ethanol 10%, Max MTBE 15%)	Blade Length	15" / 38 cm
Fuel tank capacity	3.5 gallons / 13.25 liters	Gauge Wheels	4 Adjustable
Cooling	Air cooled	Sprung Seat	Standard
Air filter	Standard	Hinged Arm Rests	Optional
Alternator	12V	Service Minder	Digital
Starter	Electric	Blade Engagement	Electromagnetic clutch
Transmission		Deck Construction	Stamped
Transmission	Hydrostatic transaxles	Productivity	2.8 acres/h / 11,331 m ² /h
Steering control	Dual levers, foam gripped	Dimensions	
Speed forward	0-6.5 mph / 0-10.5 km/h	Weight	640 lbs / 2590 kg
Speed reverse	0-3.5 mph / 0-5.6 km/h	Base Machine Length	75" / 191 cm
Brakes	Mechanical park brake	Base Machine Height	40" / 102 cm
Front caster tires	11 x 6 - 5	Base Machine Width	43.75" / 112 cm
Rear tires, turf pneumatic	18 x 9.5-8	Overall Width, Chute Up	57" / 145 cm
Tire pressure	15 PSI / 103 kPa / 1 bar	Overall Width, Chute Down	67.5" / 171 cm

¹⁾ The power rating as declared by the engine manufacturer is the average gross power output at the specified RPM of a typical production engine for the engine model measured using SAE Standards for engine gross power. Refer to the engine manufacturer engine specifications.

TECHNICAL DATA

Torque Specifications

Engine crankshaft bolt	75 ft/lb (100 Nm)	Standard ¼" fasteners	9 ft/lb (12 Nm)
Deck pulley bolts	75 ft/lb (100 Nm)	Standard 5/16" fasteners	18 ft/lb (25 Nm)
Lug nuts	75 ft/lb (100 Nm)	Standard 3/8" fasteners	33 ft/lb (44 Nm)
Blade bolt	60 ft/lb (81 Nm)	Standard 7/16" fasteners	52 ft/lb (70 Nm)
		Standard ½" fasteners	80 ft/lb (110 Nm)

Accessories

Collection system

HEX HEAD CAP SCREWS

The torque values shown should be used as a general guideline when specific torque values are not given.

U.S. Standard Hardware

Grade		SAE Grade 5		SAE Grade 8		Flangelock Screw w/Flangelock Nut	
Size		ft./lbs	Nm	ft./lbs	Nm	ft./lbs	Nm
Shank Size (Diameter in inches, fine or coarse thread)	¼	9	12	13	18		
	5/16	18	24	28	38	24	33
	3/8	31	42	46	62	40	54
	7/16	50	68	75	102		
	½	75	102	115	156		
	9/16	110	149	165	224		
	5/8	150	203	225	305		
	¾	250	339	370	502		
	7/8	378	512	591	801		
	1 1/8	782	1060	1410	1912		

** Grade 5 - Minimum commercial quality (lower quality not recommended)

Metric Standard Hardware

Grade		Grade 8.8		Grade 10.9		Grade 12.9	
Size		ft./lbs	Nm	ft./lbs	Nm	ft./lbs	Nm
Shank Size (Diameter in inches, fine or coarse thread)	M4	1.5	2	2.2	3	2.7	3.7
	M5	3	4	4.5	6	5.2	7
	M6	5.2	7	7.5	10	8.2	11
	M7	8.2	11	12	16	15	20
	M8	13.5	18	18.8	25	21.8	30
	M10	24	33	35.2	48	43.5	59
	M12	43.5	59	62.2	84	75	102
	M14	70.5	96	100	136	119	161
	M16	108	146	147	199	176	239
	M18	142	193	202	274	242	328
	M20	195	264	275	373	330	447
	M22	276	374	390	529	471	639
	M24	353	478	498	675	596	808
M27	530	719	735	996	904	1226	

SERVICE JOURNAL

Action	Date, mtr reading, stamp, sign
Delivery Service	
Charge the battery	<input type="checkbox"/>
Adjust the tire pressure of all wheels to 15 PSI (1 bar)	<input type="checkbox"/>
Mount the steering controls in the normal position	<input type="checkbox"/>
Connect the contact box to the cable for the seat's safety switch	<input type="checkbox"/>
Check that the right amount of oil is in the engine	<input type="checkbox"/>
Adjust the position of the steering controls	<input type="checkbox"/>
Fill with fuel and open the fuel shut off valve	<input type="checkbox"/>
Start the engine	<input type="checkbox"/>
Check that there is drive to both wheels	<input type="checkbox"/>
Check the mower deck adjustment	<input type="checkbox"/>
Check:	
The safety switch for the park brake	<input type="checkbox"/>
The safety switch for the mower deck	<input type="checkbox"/>
The safety switch in the seat	<input type="checkbox"/>
The safety switch in the steering controls	<input type="checkbox"/>
Park brake functionality	<input type="checkbox"/>
Driving forward	<input type="checkbox"/>
Driving backward	<input type="checkbox"/>
Engaging the blades	<input type="checkbox"/>
Check the idle speed	<input type="checkbox"/>
Check the engine high idle speed	<input type="checkbox"/>
Inform the customer about:	
Need and advantages of following the service schedule	<input type="checkbox"/>
Need and advantages of leaving machine for service every 300 hours	<input type="checkbox"/>
Effects of service and maintaining a service journal on machine's resale value	<input type="checkbox"/>
Application areas for mulching	<input type="checkbox"/>
Fill in the sales papers, etc.	
Delivery service has been carried out No remaining notes Certified:	

SERVICE JOURNAL

Action	Date, mtr reading, stamp, sign
<p>After the First 10 Hours Change engine oil</p>	<input type="checkbox"/>
	Date, mtr reading, stamp, sign
<p>25-Hour Service Check the fuel pump's air filter Sharpen/Replace mower blades if required Check the tire pressures Check battery with cables Lubricate according to lubrication chart Check/clean the engine's cooling air intake Clean the air cleaner's foam pre-filter</p>	<input type="checkbox"/> <input type="checkbox"/> <input type="checkbox"/> <input type="checkbox"/> <input type="checkbox"/> <input type="checkbox"/> <input type="checkbox"/>
	Date, mtr reading, stamp, sign
<p>50-Hour Service Perform the 25-hour service Clean/replace the air cleaner's paper filter cartridge (shorter intervals for dusty operating conditions) Change engine oil Lubricate according to lubrication chart Check/adjust the park brake</p>	<input type="checkbox"/> <input type="checkbox"/> <input type="checkbox"/> <input type="checkbox"/> <input type="checkbox"/>

SERVICE JOURNAL

Action	Date, mtr reading, stamp, sign
<p>100-Hour Service</p> <p>Perform the 25-hour service</p> <p>Perform the 50-hour service</p> <p>Change the engine oil filter</p> <p>Clean/replace the spark plugs</p> <p>Replace the fuel filter</p> <p>Check V-belts</p> <p>Check tighten caster wheel axle bolts (every 200 hours)</p> <p>Change the air filter's paper cartridge</p> <p>Change hydraulic pump oil and filter. (200 hours)</p>	<p><input type="checkbox"/></p> <p><input type="checkbox"/></p> <p><input type="checkbox"/></p> <p><input type="checkbox"/></p> <p><input type="checkbox"/></p> <p><input type="checkbox"/></p> <p><input type="checkbox"/></p> <p><input type="checkbox"/></p> <p><input type="checkbox"/></p>
<p>300-Hour Service</p> <p>Perform the 25-hour service</p> <p>Perform the 50-hour service</p> <p>Perform the 100-hour service</p> <p>Check/adjust the mower deck</p> <p>Clean the combustion chamber and grind the valve seats</p> <p>Check the engine valve clearance</p> <p>Replace the air cleaner's foam pre-filter</p>	<p><input type="checkbox"/></p> <p><input type="checkbox"/></p> <p><input type="checkbox"/></p> <p><input type="checkbox"/></p> <p><input type="checkbox"/></p> <p><input type="checkbox"/></p> <p><input type="checkbox"/></p>

SERVICE JOURNAL

Action	Date, mtr reading, stamp, sign
<p>At Least Once Each Year</p> <p>Clean the engine's cooling air intake (25 hours)</p> <p>Replace the air cleaner's foam pre-filter (300 hours)</p> <p>Replace the air filter's paper cartridge</p> <p>Change the engine oil (50 hours)</p> <p>Replace the engine oil filter (100 hours)</p> <p>Check/adjust the cutting height</p> <p>Check/adjust the park brake (50 hours)</p> <p>Clean/Change the spark plugs (100 hours)</p> <p>Change the fuel filter (100 hours)</p> <p>Check the engine valve clearance</p>	<p><input type="checkbox"/></p> <p><input type="checkbox"/></p> <p><input type="checkbox"/></p> <p><input type="checkbox"/></p> <p><input type="checkbox"/></p> <p><input type="checkbox"/></p> <p><input type="checkbox"/></p> <p><input type="checkbox"/></p> <p><input type="checkbox"/></p> <p><input type="checkbox"/></p>

NEED MORE HELP?

You'll find the answer and more on managemyhome.com - for free!

- Find this and all your other product manuals online.
- Get answers from our team of home experts.
- Get a personalized maintenance plan for your home.
- Find information and tools to help with home projects.

manage my home

brought to you by Craftsman

Get it fixed, at your home or ours!

Your Home

For repair - **in your home** - of all major brand appliances, lawn and garden equipment, or heating and cooling systems, **no matter who made it, no matter who sold it!**

For the replacement parts, accessories and owner's manuals that you need to do-it-yourself.

For Sears professional installation of home appliances and items like garage door openers and water heaters.

1-800-4-MY-HOME® Anytime, day or night
(1-800-469-4663) (U.S.A. and Canada)
www.sears.com **www.sears.ca**

Our Home

For repair of carry-in products like vacuums, lawn equipment, and electronics, call or go on-line for the nearest **Sears Parts and Repair Center**

1-800-488-1222 Anytime, day or night (U.S.A. only)
www.sears.com

To purchase a protection agreement (U.S.A.) or maintenance agreement (Canada) on a product serviced by Sears:

1-800-827-6655 (U.S.A.) **1-800-361-6655** (Canada)

Para pedir servicio de reparación a domicilio, y para ordenar piezas:

1-888-SU-HOGAR®
(1-888-784-6427)

Au Canada pour service en français:

1-800-LE-FOYER^{MC}
(1-800-533-6937)
www.sears.ca

Sears

© Sears Brands, LLC

® Registered Trademark / ™ Trademark / ™ Service Mark of Sears Brands, LLC

® Marca Registrada / ™ Marca de Fábrica / ™ Marca de Servicio de Sears Brands, LLC

^{MC} Marqué de commerce / ^{MD} Marqué déposée de Sears Brands, LLC