

KitchenAid™

STAND MIXER



FOR THE WAY IT'S MADE.™

Table of Contents

- Important Safety Instructions3
- Electrical Requirements for Brazil Only4
- About Your Mixer
 - Tilt Head Mixer Features.....5, 6
 - Bowl Lift Mixer Features.....7, 8
 - Using Your KitchenAid™ Attachments9
 - Beater-to-Bowl Clearance9
 - Care and Cleaning of Your Mixer9
 - Planetary Mixing Action10
 - Mixer Use.....10
 - Speed Control Guide.....10
- Mixing Tips.....11
 - Mixing and Kneading Yeast Dough11, 12
 - Egg Whites12
 - Whipped Cream.....12
- Before You Call For Service13

Important Safety Instructions

When reading the Instructions Manual...

Pay special attention to sections marked by the following words:

⚠WARNING

These help you avoid accidents that could lead to injury for someone using the product incorrectly.

⚠CAUTION

These help you avoid damage to the product and/or other property.

“NOTE” or “IMPORTANT”

These sections give you helpful tips on using the product.

⚠WARNING

TO REDUCE THE RISK OF FIRE, ELECTRICAL SHOCK, INJURY TO PERSONS, OR DAMAGE WHEN USING THE MIXER, FOLLOW BASIC PRECAUTIONS, INCLUDING THE FOLLOWING:

1. Read all instructions.
2. To protect against risk of electrical shock, never immerse mixer in water or other liquid.
3. Be sure that the prongs on the plug of the unit mate with the electrical wall receptacle into which it will be plugged. Observation of proper grounding techniques and local electrical codes is required.
4. Do not let children operate or play with mixer.
5. Close supervision is necessary when any appliance is used by or near children. Do not leave mixer unattended while it is operating.
6. Unplug mixer from outlet when not in use, before inserting or removing parts, and before cleaning.
7. Avoid contacting moving parts. Keep hands, hair, clothing, as well as spatulas and other utensils away from beater during operation to prevent injury, and/or damage to the mixer.
8. Do not operate mixer unattended or near edge of work surface. When used for heavy loads or at high speeds, mixer may move on work surface.
9. Remove flat beater, wire whip, or dough hook from mixer before washing.
10. Do not operate any appliance with a damaged cord set or after the appliance has been dropped or damaged in any manner. Return appliance to the nearest authorized service center for examination, repair, or adjustment.
11. The use of attachments not recommended by KitchenAid may cause fire, electrical shock, or injury.
12. Do not use outdoors.
13. Do not let cord hang over edge of table or counter, or touch hot surfaces.
14. When using a mixer model with a tilt head, the head must be completely down before locking. Before mixing, make sure lock is in position by attempting to raise head.
15. Do not use an extension cord.
16. This appliance is not intended for use by persons (including children) with reduced physical sensory or mental capabilities or lack of experience and knowledge, unless they have been given supervision or instruction concerning use of the appliance by a person responsible for their safety. If there is lack of understanding of these risks the person responsible for their safety shall prevent use of the appliance or take precautions to eliminate those risks.
17. When making dough with the mixer, never operate mixer continuously for more than 10 minutes.
18. Be careful when lifting mixer as it is heavy.
19. Use the mixer only for its intended function.
20. **ELECTRICAL REQUIREMENTS:** Your KitchenAid™ Mixer operates on a regular 220-240 volt A.C., 50-60 hertz house current. The wattage rating for your KitchenAid™ Mixer is printed on the trim band. This wattage is determined by using the attachment that draws the greatest power. Other recommended attachments may draw significantly less power.
21. Be certain the attachment hub is secure (tighten attachment knob) prior to using mixer to avoid any possibility of the attachment hub falling into the bowl during mixing.

SAVE THESE INSTRUCTIONS

Electrical Requirements for Brazil Only

! WARNING



Electric Shock Hazard

- Plug into a grounded outlet.**
- Do not use with an adaptor or T.**
- Do not use with an extension cord.**
- Failure to follow these instructions could result in death, fire, or electric shock.**

Use appropriate outlet type for your appliance plug, as shown below:

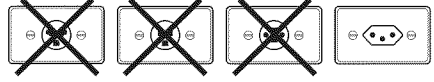

Before operating this appliance, make sure the main voltage at the installation site is the same as indicated on product technical data label.

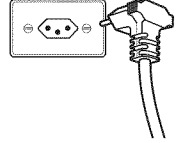

This information is also included on the label attached to your appliance's cord near the plug.

IMPORTANT:

- If it is necessary to convert your 127V appliance to 220V, use a 1.0 KVA stabiliser.
- If it is necessary to convert your 220V appliance to 127V, use a 1.0 KVA stabiliser.

- Never plug your appliance into multi-plug adapters with another appliance in the same socket.

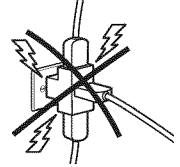

Do not use an extension cord. This type of connection may cause electrical overload in the mains, and can damage the appliance and could cause a fire. The appliance should be plugged into its own outlet.

- In case of oscillation in mains voltage, install an automatic voltage stabiliser with minimum rating of 1500 Watts between the appliance and the socket.
- If the cord of this appliance is damaged, it must be replaced. Contact your nearest authorized KitchenAid Customer Care Center.

Residence mains:

The mains wires must be of copper with a minimum cross-section per ABNT (NBR-5410.)

To protect this appliance and the mains against over loading, this appliance must be connected to a circuit that is protected with a thermo-magnetic circuit breaker.

If the household circuit does not include a circuit breaker, contact an electrician to have one installed.

Electric outlet:

For your safety and to avoid damage to your product, it is very important that your product is earthed correctly.

Your appliance power cord features a hexagon-shaped plug, 12A, per ABNT (NBR 14136).

Your residence electrical installation must have a suitable electric outlet for this type of plug. If not, it is your responsibility to have one installed by a qualified electrician.

Tilt Head Mixer Features

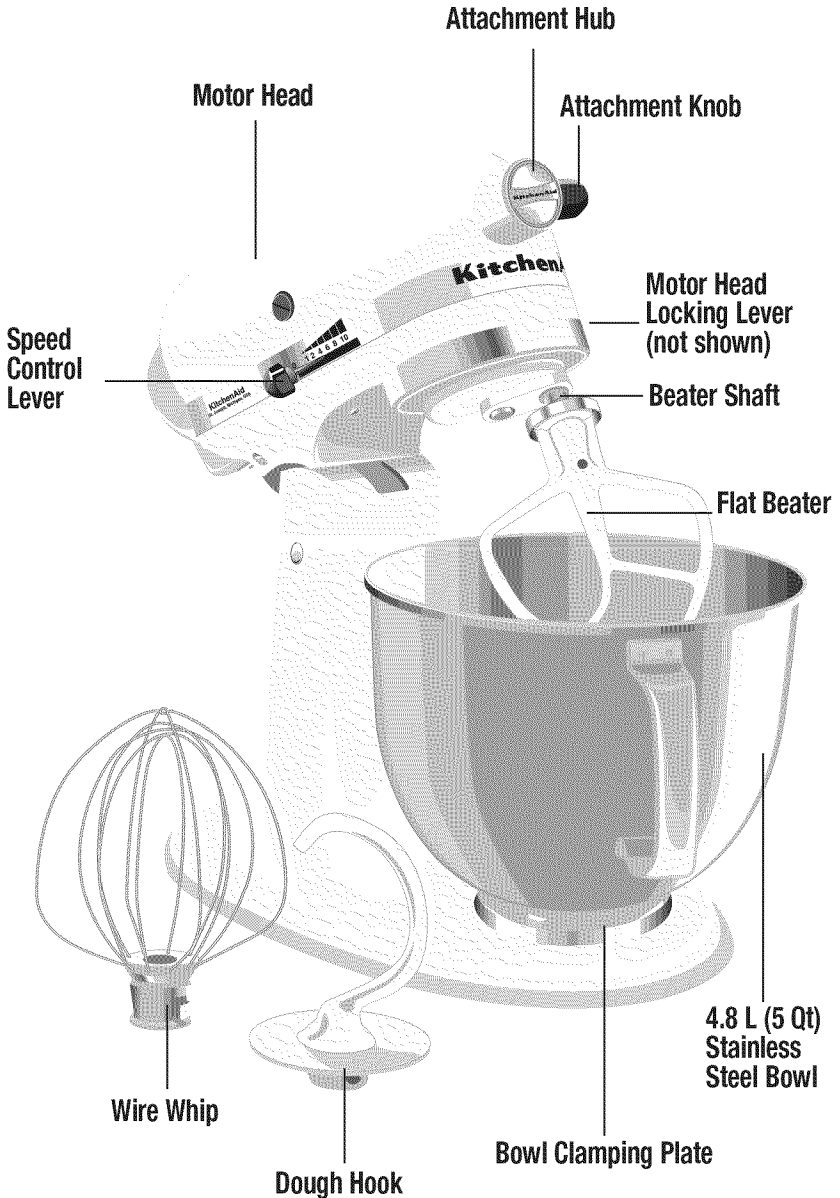

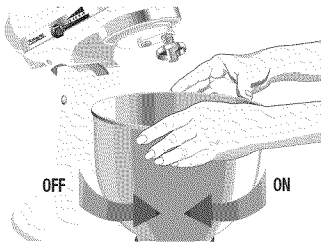

TO ATTACH BOWL

- Be sure speed control is OFF.
- Tilt motor head back.
- Place bowl on bowl-clamping plate.
- Turn bowl gently in clockwise direction (see picture above).
- Sit pouring shield on bowl.*
* If Pouring Shield is included

TO REMOVE BOWL

- Turn speed control to OFF.
- Tilt motor head back.
- Turn bowl in counterclockwise direction.

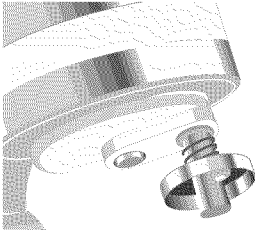

TO ATTACH FLAT BEATER, WIRE WHIP, OR DOUGH HOOK

- Turn speed control to OFF and unplug.
- Raise motor head.
- Slip beater onto beater shaft and press upward as far as possible.
- Turn beater to right, hooking beater over pin on shaft.

TO REMOVE FLAT BEATER, WIRE WHIP, OR DOUGH HOOK

- Turn speed control to OFF and unplug.
- Raise motor head.
- Press beater upward as far as possible and turn left.
- Pull beater from beater shaft.

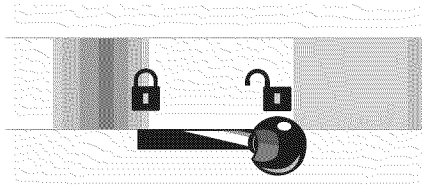

TO LOCK MOTOR HEAD IN RAISED POSITION

- Push locking lever into UNLOCK position and hold.
- Tilt motor head back.
- Move locking lever into LOCK position.

TO LOCK MOTOR HEAD IN OPERATING POSITION

- Push locking lever into UNLOCK position and hold.
- Lower motor head until it is completely down into operating position.
- Move locking lever into LOCK position.
- Before mixing, test motor head lock by attempting to raise head.

NOTE: Motor head should always be kept in LOCK position when using mixer.

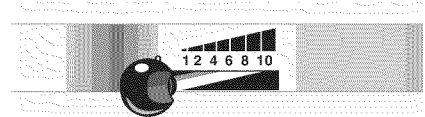

TO OPERATE CONTROL SPEED

- Speed control lever should always be set on lowest speed for starting, then gradually moved to desired higher speed to avoid splashing ingredients out of bowl. See "Speed Control Guide."

Bowl Lift Mixer Features

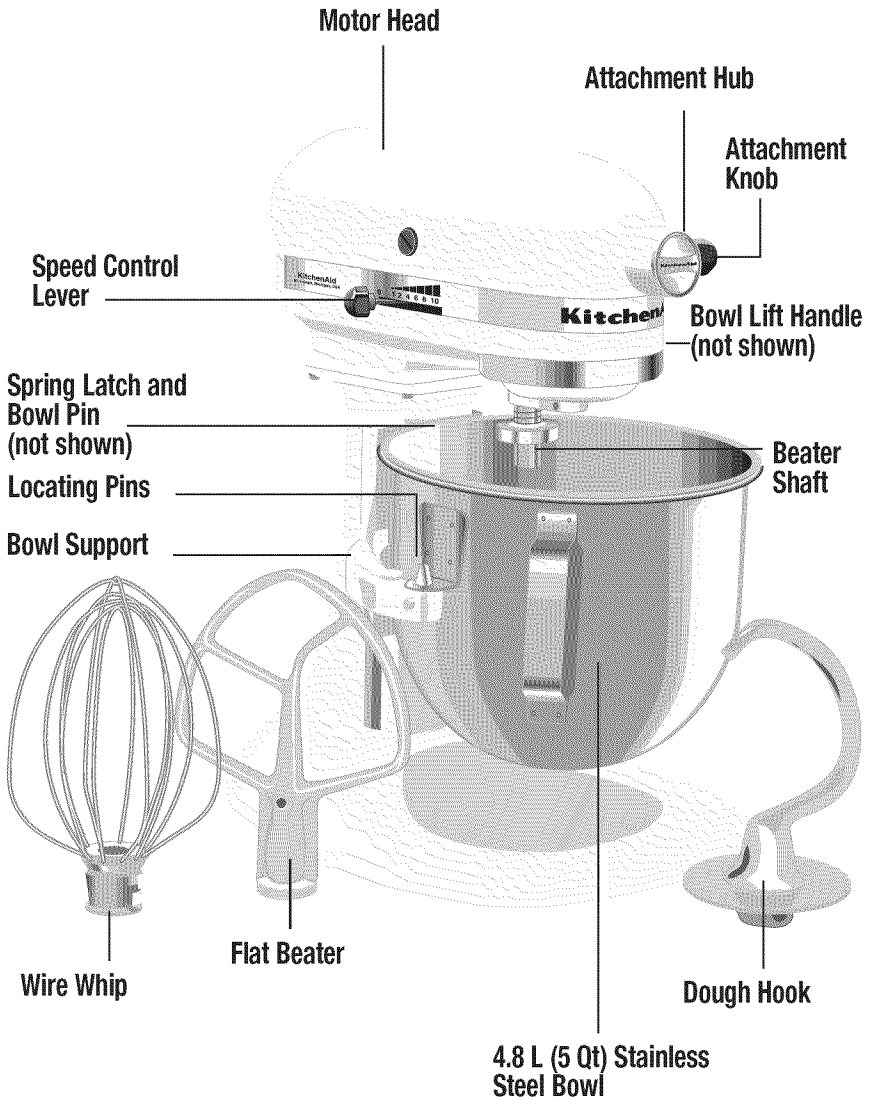

TO ATTACH BOWL

- Be sure speed control is OFF.
- Place bowl lift handle in down position.
- Fit bowl supports over locating pins.
- Press down on back of bowl until bowl pin snaps into spring latch.
- Sit pouring shield* on bowl.
- Raise bowl before mixing.

TO ATTACH POURING SHIELD*

1. Turn speed control to OFF.
2. Unplug Stand Mixer or disconnect power.
3. Attach Flat Beater, Dough Hook, or Wire Whip and bowl.
4. From the front of the mixer, slide the Pouring Shield over the bowl until the shield is centered. The bottom rim of the shield should fit within the bowl.

TO REMOVE POURING SHIELD

1. Turn speed control to OFF.
2. Unplug Stand Mixer or disconnect power.
3. Lift the front of the Pouring Shield clear of the bowl rim and pull forward.
4. Remove attachment and bowl.

TO USE POURING SHIELD

1. For best results, rotate the shield so the motor head covers the “u” shaped gap in the shield. The pouring chute will be just to the right of the attachment hub as you face the mixer.
2. Pour the ingredients into the bowl through the pouring chute.

* If Pouring Shield is included

NOTE: Check that bowl and pouring shield are properly in place.

TO REMOVE BOWL

- Place bowl lift handle in down position.
- Grasp bowl handle and lift straight up and off locating pins.

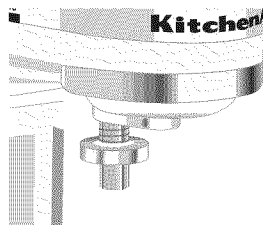
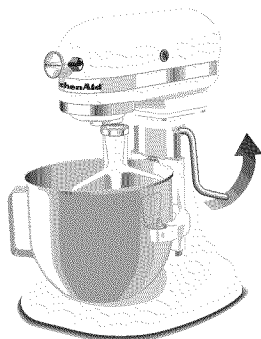

TO RAISE BOWL

- Rotate handle back and up until it snaps into the locked vertical position.
- Bowl must always be in raised, locked position when mixing.

TO LOWER BOWL

- Rotate handle back and down.

TO ATTACH FLAT BEATER, WIRE WHIP, OR DOUGH HOOK

- Turn speed control to OFF and unplug.
- Lower bowl by rotating bowl lift handle downward.
- Slip flat beater on beater shaft and press upward as far as possible.
- Turn beater to right, hooking beater over the pin on shaft.

TO REMOVE FLAT BEATER, WIRE WHIP, OR DOUGH HOOK

- Turn speed control to OFF and unplug.
- Lower bowl by rotating bowl lift handle downward.
- Press beater upward as far as possible and turn left.
- Pull beater from beater shaft.

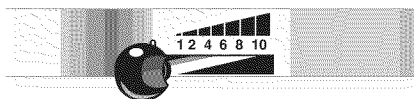

TO OPERATE SPEED CONTROL

- Speed control lever should always be set on lowest speed for starting, then gradually moved to desired higher speed to avoid splashing ingredients out of bowl. See “Speed Control Guide.”

OVERLOAD RESET BUTTON (Model 5KPM50 only)

- If the mixer is overloaded, the Overload Reset Button will pop out and the mixer will shut off. Turn the Speed Control Lever to OFF. Wait a few minutes, then push in the Overload Reset Button. Turn the Speed Control Lever to the desired speed and continue mixing.

Using Your KitchenAid™ Attachments

See the Stand Mixer Attachments Use and Care Guide for speed settings and operating times.

Flat Beater, for normal to heavy mixtures, such as:

cakes	biscuits
creamed frostings	crumpets
candies	meat loaf
cookies	mashed potatoes
pie pastry	

Wire Whip for mixtures that need to incorporate air, such as:

eggs	sponge cakes
egg whites	mayonnaise
heavy cream	some candies
boiled frostings	

Dough Hook for mixing and kneading yeast doughs, such as:

bread	coffee cakes
rolls	buns

Beater-to-Bowl Clearance

Your mixer is adjusted at the factory so that the flat beater just clears the bottom of the bowl. If, for any reason, the flat beater strikes the bottom of the bowl, or is too far away from the bowl, clearance can be corrected as follows:

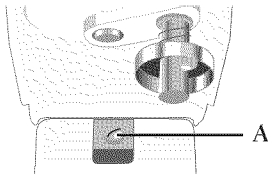

Tilt Head

- Lift motor head.
- Turn screw (A) slightly to the left to raise flat beater and to the right to lower flat beater.
- Make adjustment with flat beater, so it just clears surface of bowl.

Bowl Lift

- Place bowl lift handle in down position.
- Turn screw (B) slightly to the left to raise flat beater and to the right to lower flat beater.
- Make adjustments with flat beater, so it just clears surface of bowl.

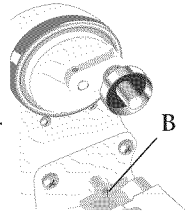

NOTE: Flat beater must not strike on bottom or side of bowl when properly adjusted. If beater or wire whip is adjusted too close so that it strikes bottom of bowl, coating may wear off of beaters or wires may wear through on wire whip. Scraping sides of bowl may be necessary under certain conditions regardless of beater adjustment. Mixer must be stopped to scrape bowl or damage to mixer may occur.

Care and Cleaning of Your Mixer

⚠ WARNING

ELECTRICAL SHOCK HAZARD
ALWAYS BE SURE TO UNPLUG MIXER BEFORE CLEANING TO AVOID POSSIBLE ELECTRICAL SHOCK. Wipe mixer with a damp cloth. DO NOT IMMERSE IN WATER. Wipe off beater shaft frequently, removing any residue that may accumulate.

Bowl, flat beater, and dough hook may be washed in an automatic dishwasher. The wire whip and these other basic accessories can be cleaned thoroughly in hot sudsy water and rinsed completely before drying.

Lubrication: Motor bearings are self-lubricating and should require no further attention under normal use.

Planetary Mixing Action

During operation, the flat beater moves around the stationary bowl, at the same time turning in the opposite direction on its own axis. The diagram shows the complete coverage of the bowl made by the path of the beater.

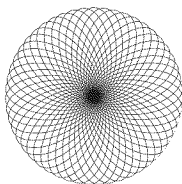

Your KitchenAid™ Mixer will mix faster and more thoroughly than most other electric mixers. Therefore, the mixing time in most recipes must be adjusted to avoid overbeating.

Mixer Use

The bowl and beater are designed to provide thorough mixing without frequent scraping. Scraping the bowl once or twice during mixing is usually sufficient.

The mixer may warm up during use. Under heavy loads with extended mixing time, you may not be able to comfortably touch the top of the unit. This is normal.

⚠ WARNING

PERSONAL INJURY HAZARD

To avoid personal injury and damage to the beater, do not attempt to scrape bowl while mixer is operating; turn mixer off. Should scraper or other object drop into bowl, turn motor OFF before removing.

Speed Control Guide

NUMBER OF SPEED

1	STIR	For slow stirring, combining, mashing, starting all mixing procedures. Use to add flour and dry ingredients to batter, add liquids to dry ingredients, and combine heavy mixtures.
2	SLOW MIXING	For slow beating, mashing, faster stirring. Use to beat heavy batters and candies, start mashing potatoes or other vegetables, cut shortening into flour, beat thin or splashy batters, and mix and knead yeast dough. Use with Can Opener attachment.
4	MIXING, BEATING	For mixing semi-heavy batters such as cookies. Use to cream sugar and shortening and add sugar to egg whites for meringues. Medium speed for cake mixes. Use with attachments: Food Grinder, Rotor Slicer/Shredder, and Fruit/Vegetable Strainer.
6	BEATING, CREAMING	For beating or creaming, medium fast whipping. Use to finish mixing cakes, doughnut, and other batters. High speed for cake mixes. Use with Citrus Juice attachment.
8	FAST BEATING, WHIPPING	For whipping cream, egg whites, and boiled frostings.
10	FAST WHIPPING	For whipping small amounts of cream and egg whites. Use with Pasta Maker and Grain Mill attachments.

NOTE: The Speed Control Lever can be set between the above speeds if a finer adjustment is required.

Mixing Tips

Converting Your Recipe to the Mixer

The mixing instructions found in this book can be used to convert your favorite recipes for use with your KitchenAid™ Mixer.

To help determine a mixing procedure, your own observations and experience will be needed. Watch the batter or dough and mix only until it has the desired appearance described in your recipe, such as “smooth and creamy.” Use the “Speed Control Guide” to help determine proper mixing speeds.

Adding Ingredients

The standard procedure to follow when mixing most batters, especially cake and cookie batters, is to add:

- 1/3 dry ingredients
- 1/2 liquid ingredients
- 1/3 dry ingredients
- 1/2 liquid ingredients
- 1/3 dry ingredients

Use Stir Speed until ingredients have been blended. Then *gradually* increase to desired speed.

Always add ingredients as close to side of bowl as possible, not directly into moving beater. The Pouring Shield can be used to simplify adding ingredients.

NOTE: If ingredients in very bottom of bowl are not thoroughly mixed, the beater is not far enough into the bowl. See “Beater to Bowl Clearance.”

Cake Mixes

When preparing packaged cake mixes, use Speed 4 for medium speed and Speed 6 for high speed. For best results, mix for the time stated on the package directions.

Adding Nuts, Raisins or Candied Fruits

Solid materials should be folded in the last few sections of mixing on Stir Speed. The batter should be thick enough to keep the fruits and nuts from sinking to the bottom of the pan during baking. Sticky fruits should be dusted with flour for better distribution in the batter.

Liquid Mixture

Mixtures containing large amounts of liquid ingredients should be mixed at lower speeds to avoid splashing. Increase speed only after mixture has thickened.

Mixing and Kneading Yeast Dough

1. Place all dry ingredients including yeast into bowl, except last 250 mL to 500 mL flour.
2. Attach bowl and dough hook. Lock Tilt Head down or raise Bowl Lift Handle to up position. Turn to Speed 2 and mix about 15 seconds or until ingredients are combined.

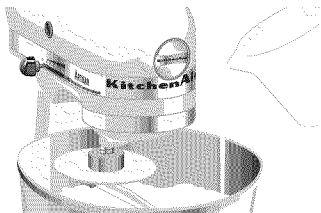

3. Continuing on Speed 2, gradually add liquid ingredients to flour mixture, about 30 seconds to 1 minute. Mix 1 minute longer.

NOTE: If liquid ingredients are added too quickly, they will form a pool around the dough hook and slow down mixing process.

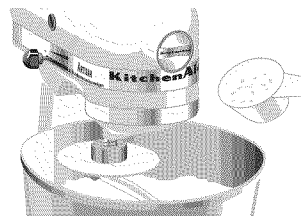

4. Continuing on speed 2, gently tap remaining flour around sides of bowl, 125 mL at a time, as needed. Mix until dough clings to hook and cleans sides of bowl, about 2 minutes.

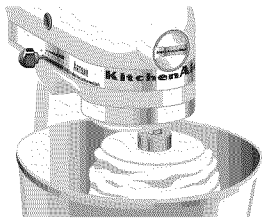

5. When dough clings to hook, knead on Speed 2 for 2 minutes or until dough is smooth and elastic.

6. Unlock and raise Tilt Head or lower bowl on Bowl Lift and remove dough from hook.

NOTE: These instructions illustrate bread making with the Rapid Mix method. When using the conventional method, dissolve yeast in warm water in warmed bowl. Add remaining liquids and dry ingredients – except last 250 mL to 500 mL flour. Turn to Speed 2 for about 1 minute, or until ingredients are thoroughly mixed. Proceed with steps 4 through 6.

Egg Whites

Place room temperature egg whites in clean, dry bowl. Attach bowl and wire whip. To avoid splashing, *gradually* turn to designated speed and whip to desired stage. See chart below.

<u>Amount</u>	<u>Speed</u>
1 egg white	Gradually to 10
2-4 egg whites	Gradually to 8
6 or more egg whites	Gradually to 6

WHIPPING STAGES

Frothy:

Large, uneven air bubbles.

Begin to hold shape:

Air bubbles are fine and compact; product is white.

Soft peak:

Tips of peaks fall over when wire whip is removed.

Almost stiff:

Sharp peaks form when wire whip is removed, but whites are actually soft.

Stiff but not dry:

Sharp, stiff peaks form when wire whip is removed. Whites are uniform in color and glisten.

Stiff and dry:

Sharp, stiff peaks form when wire whip is removed. Whites are speckled and dull in appearance.

Whipped Cream

Pour cream into chilled bowl. Attach bowl and wire whip. To avoid splashing, *gradually* turn to designated speed and whip to desired stage. See chart below.

<u>Amount</u>	<u>Speed</u>
59 mL	Gradually to 10
118 mL	Gradually to 10
236 mL	Gradually to 8
472 mL	Gradually to 8

WHIPPING STAGES

Begins to thicken:

Cream is thick and custard-like.

Holds its shape:

Cream forms soft peaks when wire whip is removed. Can be folded into other ingredients when making desserts and sauces.

Stiff:

Cream stands in stiff, sharp peaks when wire whip is removed. Use for topping on cakes or desserts, or filling for cream puffs.

NOTE: Watch cream closely during whipping; there are just a few seconds between whipping stages. DO NOT OVERWHIP.

Before You Call For Service

Please read the following before calling your service center.

1. The mixer may warm up during use. Under heavy loads with extended mixing time periods, you may not be able to comfortably touch the top of the unit. This is normal.
2. The mixer may emit a pungent odor, especially when new. This is common with electric motors.
3. If flat beater strikes bowl, stop the mixer. See "Beater-to-Bowl Clearance."

If your mixer should malfunction or fail to operate, please check the following:

1. Is your mixer plugged in?
2. Is the fuse in the circuit to the mixer in working order? If you have a circuit breaker box, be sure the circuit is closed.

3. Are the bowl and pouring shield* properly in place?
4. Model 5KPM50 is equipped with an overload device. If the mixer is overloaded, the Overload Reset Button will pop out and the mixer will shut off (see page 7). Turn the Speed Control Lever to OFF. Wait a few minutes, then push in the Overload Reset Button. Turn the Speed Control Lever to the desired speed and continue mixing.

HOW TO OBTAIN SERVICE:

All service should be handled locally by an authorized KitchenAid Service Center. Contact the dealer from whom the unit was purchased to obtain the name of the nearest authorized KitchenAid service facility.

*Included with some models.

Notes

®Registered trademark/™Trademark/the shape of stand mixer is a registered trademark of KitchenAid, U.S.A.

® Marca registrada/™ Marca de comercio/la forma de la batidora con base es una marca registrada de KitchenAid, U.S.A.

®Marca registrada / TM Marca comercial/o design da batedeira Stand Mixer é uma marca registrada da KitchenAid, E.U.A.

®注册商標/™商標/台式攪機
的外觀為美國 KitchenAid 的注册商標。

스탠드 믹서의 등록 상표 ®/™상표/모양은
KitchenAid, U.S.A의 등록 상표임.



FOR THE WAY IT'S MADE.™