

ELECTRIC COOKTOP INSTALLATION INSTRUCTIONS

INSTALLATION AND SERVICE MUST BE PERFORMED BY A QUALIFIED INSTALLER.

IMPORTANT: SAVE FOR LOCAL ELECTRICAL INSPECTOR'S USE. READ AND SAVE THESE INSTRUCTIONS FOR FUTURE REFERENCE.



WARNING FOR YOUR SAFETY: Do not store or use gasoline or other flammable vapors and liquids in the vicinity of this or any other appliance.

Cooktop Dimensions

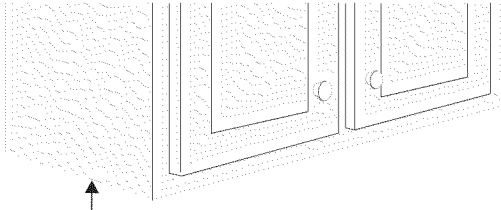

30" Min. *
(76.2 cm)

IMPORTANT INSTALLATION-INFORMATION

- All electric cooktops run off a single phase, three-wire or four-wire cable, 240/208 volt, 60 hertz, AC only electrical supply with ground.
- Please note minimum distances between cooktop and adjacent and overhead cabinetry is 30" (76.2 cm).

* 30" (76.2 cm) min. for unprotected cabinet
24" (61 cm) min. for protected surface

Cooktop Cutout Dimensions

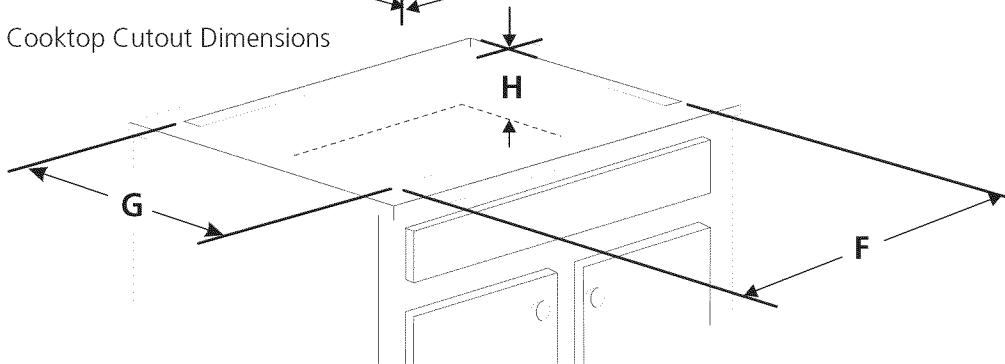

Figure 1 - 30" Model shown only

PRODUCT DIMENSIONS					
MODEL	A. WIDTH	B. DEPTH	C. HEIGHT	D. BOX WIDTH	E. BOX DEPTH
30" Ceramic Model	30 ⁵ / ₈ (77.8)	21 ³ / ₈ (54.4)	4 ³ / ₄ (12.1)	28 ¹ / ₈ (71.4)	19 (48.3)
36" Ceramic Model	36 ⁵ / ₈ (93)	21 ¹ / ₂ (54.6)	4 ³ / ₄ (12.1)	33 ¹ / ₂ (85.1)	18 ³ / ₄ (47.6)
CUT OUT DIMENSIONS					
MODEL	F. WIDTH		G. DEPTH		H. HEIGHT BELOW COOKTOP*
	MINIMUM	MAXIMUM	MINIMUM	MAXIMUM	
30" Ceramic Model	28 ¹ / ₂ (72.4)	30 (76.2)	19 ⁵ / ₈ (49.8)	20 ¹ / ₂ (52.1)	6 ¹ / ₂ (16.5)
36" Ceramic Model	33 ⁷ / ₈ (86.1)	36 (91.4)	19 ¹ / ₈ (48.6)	20 ¹ / ₂ (52.1)	6 ¹ / ₂ (16.5)

All dimensions are in inches (cm).

**Allow 2" (5 cm) space below cooktop to clear the electric cable and allow for installation of the junction box on the wall at the back of the cooktop.

Printed in China

P/N 318205428 (1311) Rev. B
English – pages 1-6
Español – pages 7-12
Français – pages 13-18

ELECTRIC COOKTOP INSTALLATION INSTRUCTIONS

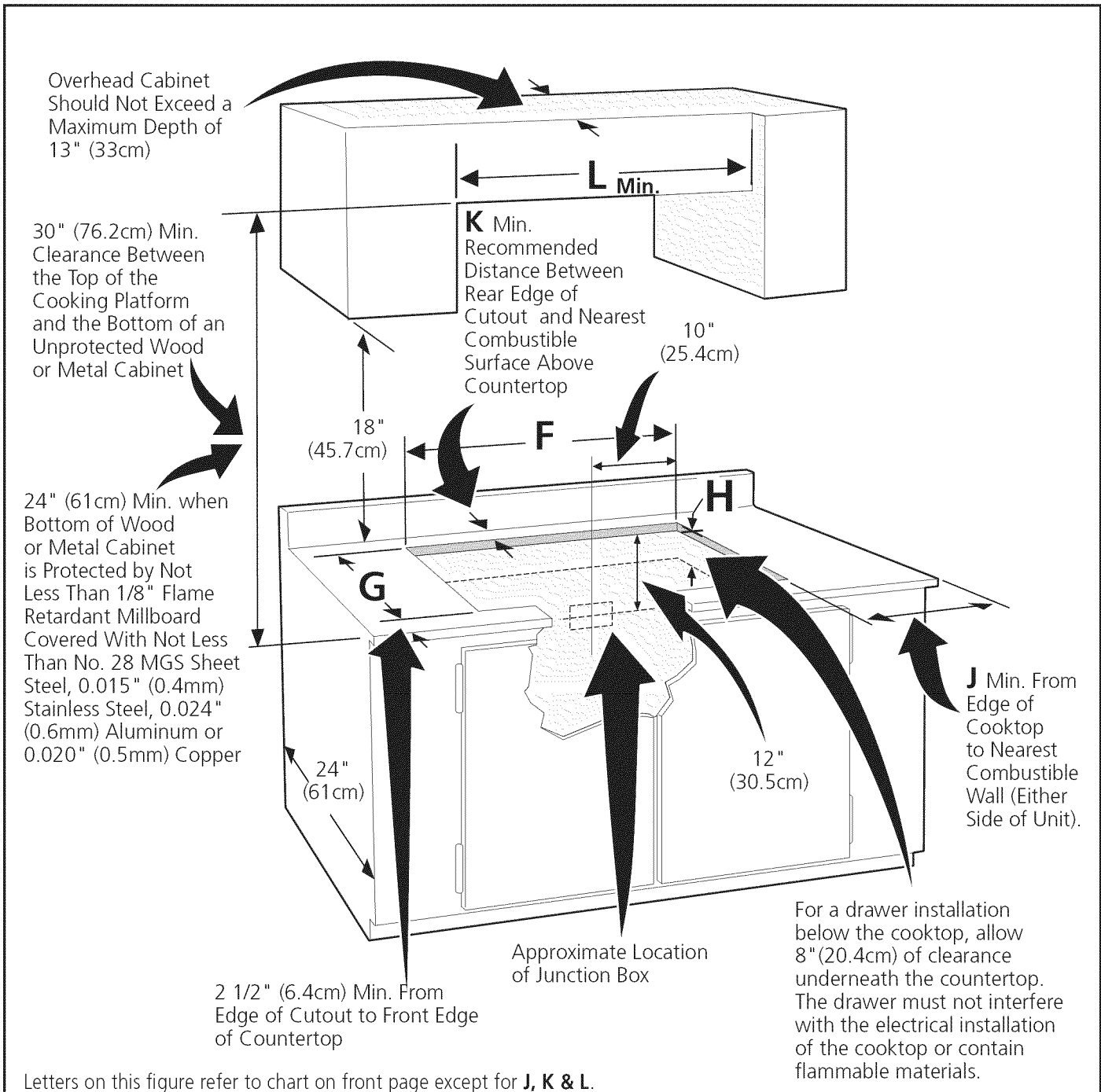

CAUTION To eliminate the risk of burns or fire resulting from reaching over heated surfaces, cabinet storage space located above the cooktop should be avoided. If cabinet storage is provided, risk can be reduced by installing a range hood that projects horizontally a minimum of 5" (12.7 cm) beyond the bottom of the cabinets.

MODEL	J	K	L
30" Ceramic Glass	7 1/2" (19.1cm)	2" (5.1cm)	30" (76.2cm)
36" Ceramic Glass	7 1/2" (19.1cm)	2" (5.1cm)	36" (91.4cm)

Figure 2 – COUNTERTOP CUTOUT OPENING

ELECTRIC COOKTOP INSTALLATION INSTRUCTIONS

Important Notes to the Installer

1. Read all instructions contained in these installation instructions before installing the appliance.
2. Remove all packing material before connecting the electrical supply to the appliance.
3. Observe all governing codes and ordinances.
4. Be sure to leave these instructions with the consumer.

Important Note to the Consumer

Keep these instructions with your Owner's Guide for the local electrical inspector's use and future reference.

IMPORTANT SAFETY INSTRUCTIONS

- Be sure your cooktop is installed and grounded properly by a qualified installer or service technician.
- These cooktops must be electrically grounded in accordance with local codes or, in their absence, with the National Electrical Code ANSI/NFPA No. 70—latest edition in the United States, or with CSA Standard C22.1, Canadian Electrical Code, Part 1, in Canada.

WARNING The electrical power to the cooktop must be shut off while line connections are being made. Failure to do so could result in serious injury or death.

Provide Electrical Connection

Install the junction box under the cabinet and run 120/240 or 120/208 Volt, AC wire from the main circuit panel. NOTE: DO NOT connect the wire to the circuit panel at this time. Wait until all wires have been connected in the junction box.

Electrical Requirements

Observe all governing codes and local ordinances.

1. A 3-wire or 4-wire single phase 120/240 or 120/208 Volt, 60 Hz AC only electrical supply is required on a separate circuit fused on both sides of the line (a 40A time-delay fuse or circuit breaker is recommended). DO NOT fuse neutral.

NOTE: Wire sizes and connections must conform with the fuse size and rating of the appliance in accordance with the National Electrical Code ANSI/NFPA No. 70—latest edition, or with CSA standard C22.1, Canadian Electrical Code, Part 1, and local codes and ordinances.

WARNING An extension cord must not be used with this appliance. Such use may result in a fire, electrical shock, or other personal injury.

2. The appliance should be connected to the fused disconnect (or circuit breaker) box through flexible armored or nonmetallic sheathed cable. The flexible armored cable extending from this appliance should be connected directly to the grounded junction box. The junction box should be located as shown in Figure 2 with as much slack as possible remaining in the cable between the box and the appliance, so it can be moved if servicing is ever necessary.
3. A suitable strain relief must be provided to attach the flexible armored cable to the junction box.

Unpacking Instructions

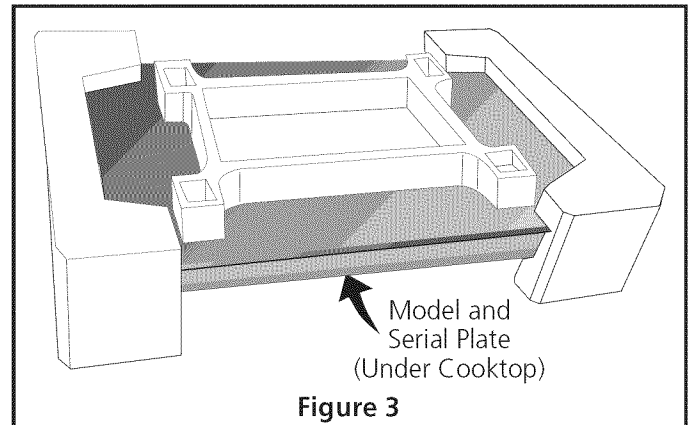

1. Leave corner supports on cooktop until completion of Electrical Connection.
2. Be sure the bottle of cleaner conditioner packed in the literature bag is left where the user can find it easily. It is important that the ceramic-glass smoothtop be pretreated before use. See **Cooktop Cleaning and Maintenance** section in the **Use and Care Guide**.

Model and Serial Number Location

The serial plate is located under the cooktop.

When ordering parts for or making inquiries about your cooktop, always be sure to include the model and serial numbers and a lot number or letter from the serial plate on your cooktop.

ELECTRIC COOKTOP INSTALLATION INSTRUCTIONS

Electrical connection

It is the responsibility and obligation of the consumer to contact a qualified installer to assure that the electrical installation is adequate and is in conformance with the National Electrical Code ANSI/NFPA No. 70-latest edition, or with CSA Standard C22.1, Canadian Electrical Code, Part 1, and local codes and ordinances.

⚠ WARNING Risk of electrical shock (Failure to heed this warning may result in electrocution or other serious injury.) This appliance is equipped with copper lead wire. If connection is made to aluminum house wiring, use only connectors that are approved for joining copper and aluminum wire in accordance with the National Electrical Code and local code and ordinances. When installing connectors having screws which bear directly on the steel and/or aluminum flexible conduit, do not tighten screws sufficiently to damage the flexible conduit. Do not over bend or excessively distort flexible conduit to avoid separation of convolutions en exposure of internal wires.

DO NOT ground to a gas supply pipe. DO NOT connect to electrical power supply until appliance is permanently grounded. Connect the ground wire before turning on the power.

⚠ WARNING (If your appliance is equipped with a white neutral conductor.) This appliance is manufactured with a white neutral power supply and a frame connected copper wire. The frame is grounded by connection of grounding lead to neutral lead at the termination of the conduit, if used in USA, in a new branch circuit installation (1996 NEC), mobile home, recreational vehicles, where local code do not permit grounding through the neutral (white) wire or in Canada, disconnect the white and green lead from each other and use ground lead to ground unit in accordance with local codes, connect neutral lead to branch circuit-neutral conductor in usual manner see Figure 5. If your appliance is to be connected to a 3 wire grounded junction box (US only), where local code permit connecting the appliance-grounding conductor to the neutral (white) see Figure 4.

NOTE TO ELECTRICIAN: The armored cable leads supplied with the appliance are UL-recognized for connection to larger gauge household wiring. The insulation of the leads is rated at temperatures much higher than temperature rating of household wiring. The current carrying capacity of the conductor is governed by the temperature rating of the insulation around the wire, rather than the wire gauge alone.

Where local codes permit connecting the appliance-grounding conductor to the neutral (white) wire (US Only) (see figure 4):

1. Disconnect the power supply.
2. In the junction box: connect appliance and power supply cable wires as shown in Figure 4.

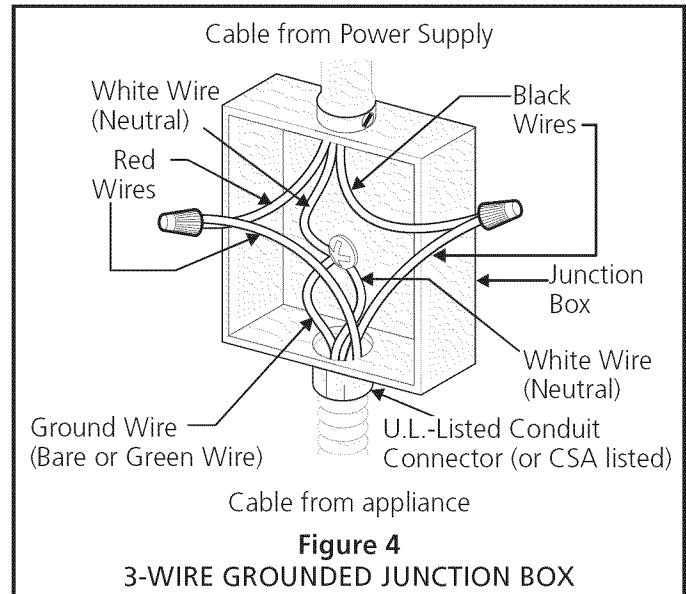

If the appliance is used in a new branch circuit installation (1996 NEC), mobile home, recreational vehicle, or where local codes DO NOT permit grounding through the neutral (white) wire, the appliance frame **MUST NOT** be connected to the neutral wire of the 4-wire electrical system (see figure 5):

1. Disconnect the power supply.
2. Separate the green (or bare copper) and white appliance cable wires.
3. In the junction box: connect appliance and power supply cable wires as shown in Figure 5.

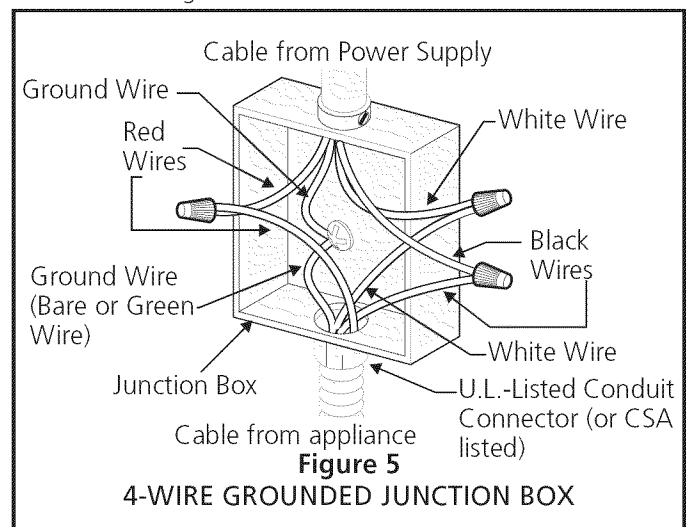

ELECTRIC COOKTOP INSTALLATION INSTRUCTIONS

Cooktop Installation

1. Visually inspect the cooktop for damage. Also make sure all cooktop screws are tight (see Figure 6).

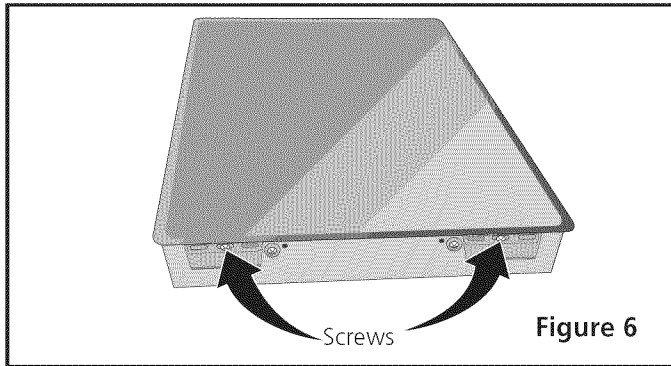

Figure 6

2. Install the retainer brackets (See Figure 7).

The retainer brackets **MUST** be installed, to meet local codes or, in their absence, with the National Electrical Code ANSI/NFPA No. 70—latest edition, or with CSA Standard C22.1, Canadian Electrical Code, Part 1 (see Figure 7 & 8).

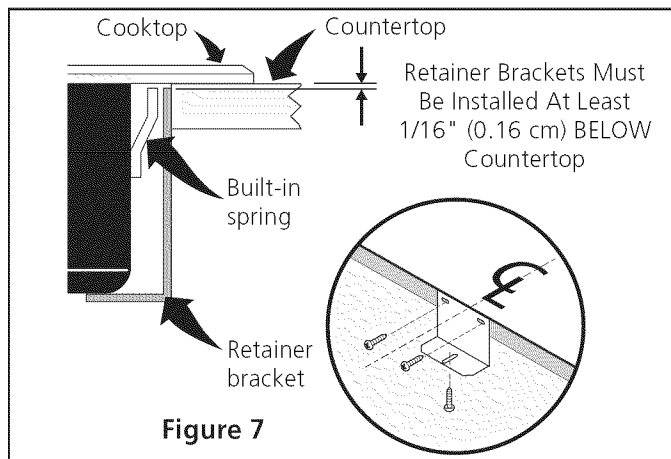

Figure 7

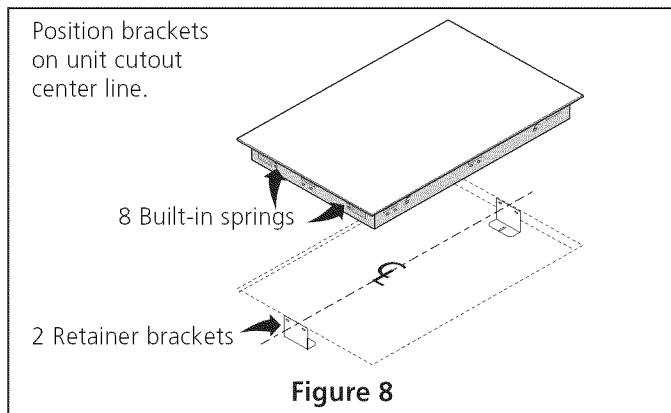

Figure 8

3. Install optional plastic spacers, if needed.

For 30" Cooktop:
If your cutout is 29 5/8" – 30", you must install spacer.

For 36" Cooktop:
If your cutout is 35" - 36", you must install spacer.

The spacers and screws can be found in a plastic bag packaged with the unit. Install those spacers using the screws at the positions illustrated on figure 9.

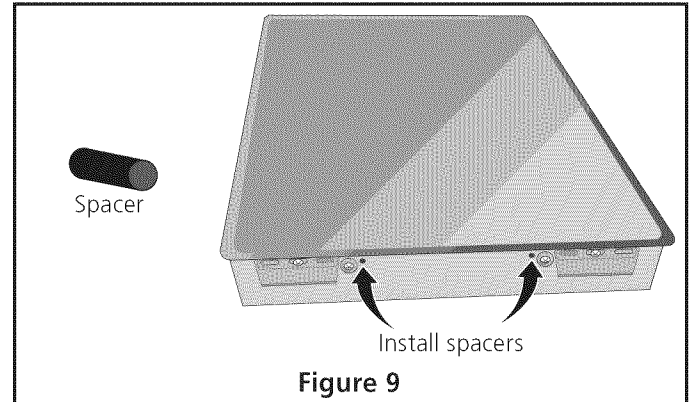

Figure 9

4. Set the cooktop into the countertop cutout.

NOTE: Do not use caulking compound; cooktop should be removable for service when needed.

Granite countertop Installation Kit

A Granite Countertop Installation kit # 903061-9010 can be ordered through a Service Center.

Checking Operation

Refer to the **Use and Care Guide** for operation.

CAUTION Do not touch cooktop glass or elements. They may be hot enough to burn you.

Before You Call for Service

Read the Before You Call for Service Checklist and operating instructions in your **Use and Care Guide**. It may save you time and expense. The list includes common occurrences that are not the result of defective workmanship or materials in this appliance.

ELECTRIC COOKTOP INSTALLATION INSTRUCTIONS

For typical under counter installation of an electric built-in oven see Figure below.

Only certain cooktop models may be installed over certain built-in electric oven models. Approved cooktops and built-in ovens are listed by the MFG ID number and product code (see the insert sheet included in the literature package and cooktop installation instructions for dimensions).

Note 1: 4" x 4" (10.2cm X 10.2cm) opening to route armored cable from cooktop to junction box.

Cabinet side filler panels are necessary to isolate the unit from adjoining cabinets. Cabinet side filler height should allow for installation of approved cooktop models

⚠ WARNING

To reduce the risk of personal injury and tipping of the wall oven, the wall oven must be secured to the cabinet(s) by mounting brackets.

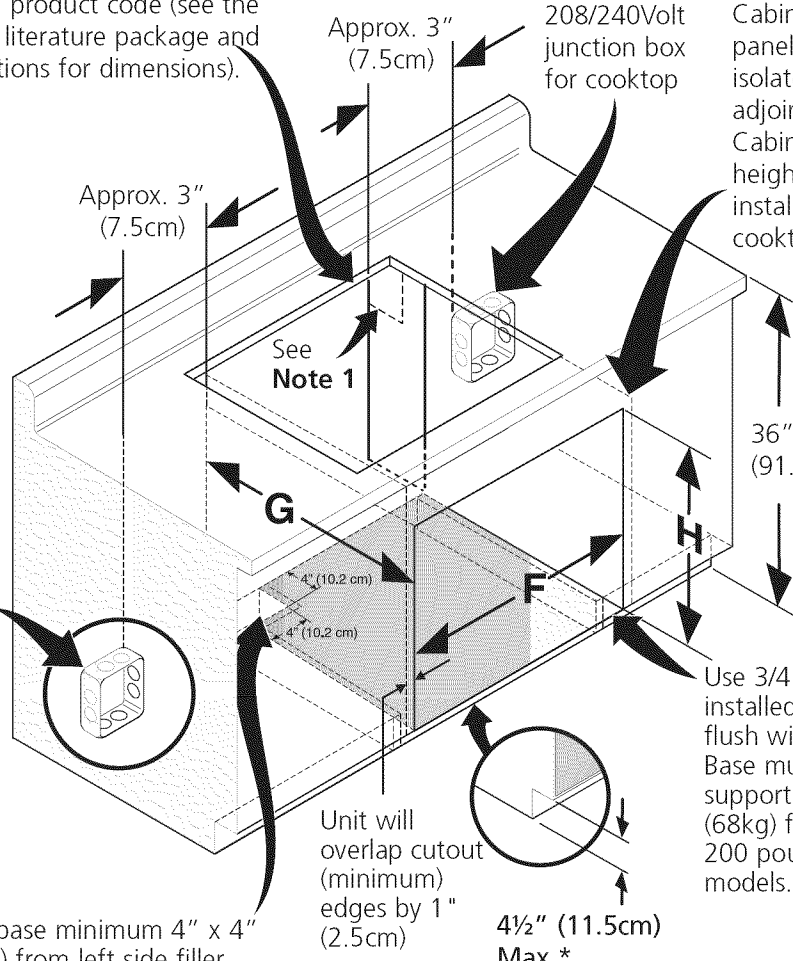

208/240 Volt junction box for built-in oven.

⚠ CAUTION

Models 790-4511* and 790-4521* are NOT approved to be combined with a wall oven in CANADA.

Use 3/4" (1.9cm) plywood, installed on two runners, flush with toe plate. Base must be capable of supporting 150 pounds (68kg) for 27" models and 200 pounds (90kg) for 30" models.

Unit will overlap cutout (minimum) edges by 1" (2.5cm)

4½" (11.5cm) Max.*

Cut an opening in wood base minimum 4" x 4" (10.2 X 10.2cm), 2" (5cm) from left side filler panel, to route armored cable to junction box.

* If no cooktop is installed directly over the oven unit, 5" (12.7cm) maximum is allowed above the floor.

CUTOUT DIMENSIONS			
	F. WIDTH	G. DEPTH	H. HEIGHT
27" (68.6cm) Wall Oven	24 ⁷ / ₈ " (63.2cm) Min. 25 ¹ / ₄ " (64.1cm) Max.	23½" (59.7cm) Min.	27¼" (69.2cm) Min. 28¼" (71.8cm) Max.
30" (76.2cm) Wall Oven	28½" (72.4cm) Min. 29" (73.7cm) Max.	23½" (59.7cm) Min.	27¼" (69.2cm) Min. 28¼" (71.8cm) Max.

Figure 9- TYPICAL UNDER COUNTER INSTALLATION OF A SINGLE ELECTRIC BUILT-IN OVEN WITH AN ELECTRIC COOKTOP MOUNTED ABOVE