

Table of Contents

Table of Contents	1
Welcome Message and Thank You	1
Important Safeguards	2
1. Specifications	3
2. Parts and Features	4
3. Operation	4
4. Troubleshooting	7
5. Limited Warranty	9

Welcome and Thank You

Welcome and thank you for purchasing this EdgeStar® wine cooler. Once you complete our easy unit set up by following this manual, it will provide you and your family years of great service.

If you are reading this owner's manual, you've probably already unpacked the unit. Note that you should save the packaging in case you need to safely transport this wine cooler in the future.

In order to assemble this wine cooler, carefully unpack all parts. The only assembly required is that of the handle(s). In order to install a handle, you need a Phillips head screwdriver, the handle(s), and the two installation screws.

- Open the door of the wine cooler.
- Locate the two screw holes on the inside of the door (they may be partially obscured by the door liner gasket).
- Insert the screws into the holes. They should now poke out of the front of the door.
- Line up the holes in the handle with the screws and give each screw about 2-4 full turns into the handle.
- Now screw the screws in all the way, and your handle is installed!

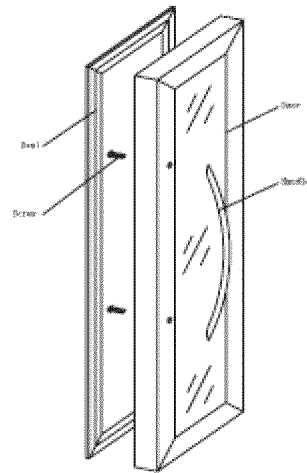

After you get the handle(s) installed, make sure that your wine cooler is fully unpacked, and position it into your preferred location (remember, for the best conditions for your wine, choose a spot in a cool (room temperature) area, away from direct sunlight leaving about 2-4 inches around all sides, specifically the back for adequate ventilation. Make sure the unit is set on a sturdy surface that can support its weight.

Note: that you can screw in and out the legs to level the unit. You may also want to clean the interior with a solution of mild soap and water and a damp cloth. Then plug the unit in, set the temperature, and fill it with wine.

At what temperatures should you set the wine cooler? Experts differ in opinion, but we recommend low to mid 50's (F) for whites and mid 60's (F) for reds. Enjoy!

IMPORTANT SAFEGUARDS

When using an electrical appliance, basic precautions should always be followed, including the following:

BEFORE USE, PLEASE READ AND FOLLOW ALL INSTRUCTIONS FOR THIS WINE COOLER

- Do not use if the power supply cord is damaged. If damaged, it must be replaced by the manufacturer or a similarly qualified technician.
- This wine cooler is not intended for use by young children or infirm persons without supervision.
- Ensure the cooler is unplugged before cleaning or if not in use.
- To clean the cooler use only mild detergents or glass cleaning products. Never use harsh detergents or solvents.
- It is not recommended to use this wine cooler with an extension cord or power strip. Please ensure that the appliance is plugged directly into an electrical outlet.
- When positioning the wine cooler, ensure that there is at least a 2" clearance on each side with 4" directly behind the cooler. This will ensure adequate ventilation of heat from the back of the cooler.
- This cooler is designed to store wine bottles. If food is placed inside, ensure that there is sufficient airflow between items. Also note that the temperature range for this cooler is optimized for wine and beverage storage. Perishable food items may require a different storage environment.
- Do not place hot food or drinks into the wine cooler before they cool down to room temperature.
- Please close the cooler door immediately after putting in or taking out wine in order to prevent inside temperature from dramatically changing.
- Avoid subjecting the cooler to external heat sources or direct sunlight.
- For a stable installation, make sure the cooler is placed on a flat, level, and solid surface.
- Make sure that the surface on which the wine cooler is placed is strong enough to hold the wine cooler once it is fully loaded with wine bottles.
- Do not place any other appliances on top of the wine cooler.
- The wine cooler is an electrical appliance. To avoid injury or death from electrical shock, do not operate the wine cooler with wet hands, while standing on a wet surface, or while standing in water.
- Do not use outdoors or in wet /moist conditions.
- Do not turn the cooler upside down, on its side, or 45° or more off level.
- Never pull the power cord to disconnect it from the outlet. Grasp the plug and pull it from the outlet.
- Never lift or carry the wine cooler by the power cord.
- Keep the power cord away from heated surfaces.
- This wine cooler is designed for household, non-commercial use only.
- Do not plug this cooler into the power socket before set up is completed.

- An empty cooler can be dangerous for children. If disposing of the cooler remove gaskets, latches, lids and the entire door from your unused appliance, or take other action to ensure that children cannot become trapped inside.
- If your model of wine cooler is equipped with a lock, take care to keep the keys away from children.
- Do not cut or remove the third prong (the grounding prong) from the power cord.
- The cord should be secured behind the unit and should not be left exposed or dangling.
- Do not move this cooler without emptying it of its contents and securing the door in a closed position.

1. Specifications

Model	TWR210EBL	
Voltage/frequency	115V/60Hz	
Power	140 W (77)	
Rated Current	2.0 A (77)	
Net Weight	46.297LB	
Protection Type	I	
Climate Type	SN • N	
Model	TWR215ESS	
Voltage/frequency	115V/60Hz	
Power	140 W (77)	
Rated Current	2.0 A (77)	
Net Weight	46.297LB	
Protection Type	I	
Climate Type	SN • N	
Model	TWR320EBL	
Voltage/frequency	115V/60Hz	
Power	210 W (77)	
Rated Current	3.0 A (77)	
Net Weight	69.887LB	
Protection Type	I	
Climate Type	SN • N	
Model	TWR325ESS	
Voltage/frequency	115V/60Hz	
Power	210 W (77)	
Rated Current	3.0 A (77)	
Net Weight	69.887LB	
Protection Type	I	
Climate Type	SN • N	

2. Parts and Features

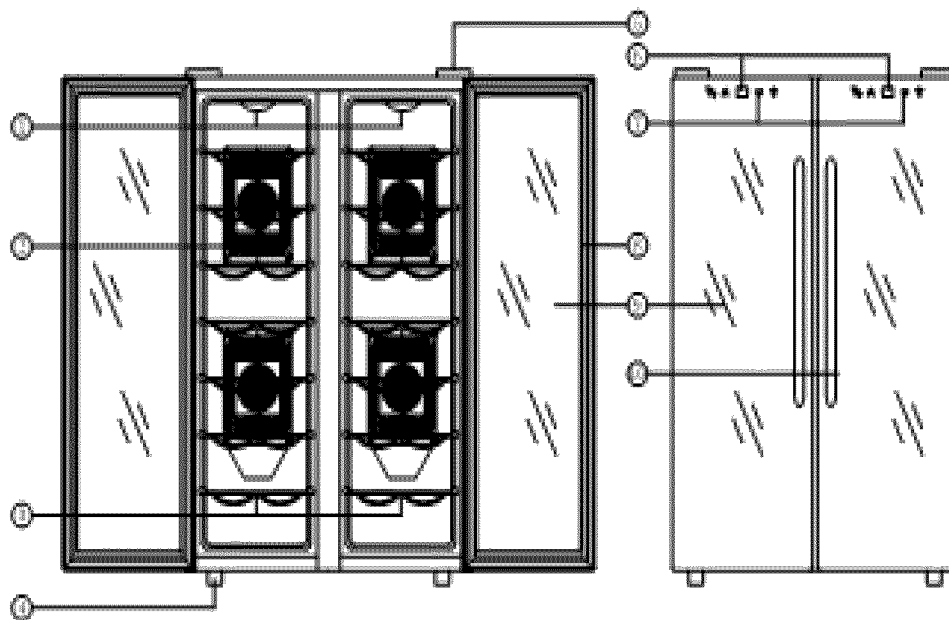

1. LIGHT 2. FAN GRATE 3. SHELF 4. FOOT
5. HINGE 6. TEMPERATURE DISPLAY
7. TEMPERATURE CONTROLS
8. DOOR FRAME 9. DOOR GLASS 10. HANDLE

Note: The above diagram is for reference only- your specific model of wine cooler will likely differ slightly from the diagram above (in light placement, bottle capacity, etc.) but its operation will be essentially the same.

3. Operation

The Temperature Control

Your wine cooler uses a digital control to adjust the thermostat- Adjust the temperature using the up and down arrows located on the wine cooler.

Interior Light

Your wine cooler is equipped with an interior light with an on/off switch. Turn the light on or off by pressing the switch.

Leveling Legs

Your wine cooler is shipped with leveling legs installed. To adjust these leveling legs, carefully lean the cooler to one side (make sure the cooler is empty and the door is secured) and unscrew the leveling legs to make them longer. Screw them in tighter to make them shorter.

Note: This cooler is not designed to operate with the leveling legs removed.

Bottle Capacity

Bottle capacity listed for your wine cooler is an estimated maximum capacity based on standard 750 mL wine bottles. For any other size bottles, capacity will vary.

Racks

Please note that the racks for your cooler have a top and a bottom. If you are having trouble fitting the stated number of bottles in the cooler (provided you have standard wine bottles), try flipping over one or more racks.

Also note that your wine cooler (depending upon the model) may have more “slots” for racks than the number of racks provided with the unit. Additional racks may be purchased from your retailer.

Door Lock (not standard on all models)

Some models of wine cooler have a factory installed lock with keys. The lock is inset to the door. To lock your cooler, insert the key into the lock and turn the key until the metal tab is fully extended.

To unlock your cooler, insert the key into the lock and turn until the metal tab is fully retracted back into the door.

Caution: Make sure to keep the key in a safe place and out of reach of children- to prevent child entrapment.

Cleaning the Cooler

- Unplug your cooler. Remove all items from it (wine bottles, shelves, etc.)
- Clean the inside surfaces with a mild cleaner. We suggest you use either warm water alone, or a baking soda solution (try mixing 2 tablespoons of baking soda into a quart of water.)
- Clean the wire shelves/trays (if you have them) with a mild detergent solution.
- Clean the wooden shelves/trays (if you have them) with a soft cloth and wood cleaner.
- Wash the outside of the cooler with a mild detergent solution.
- Dry any wet parts with a soft cloth.

Caution: make sure to minimize the exposure of water to any electronic or control parts.

Extended Periods of Disuse

Your cooler can operate safely for three weeks or longer without any adjustments. However, if the cooler is to be left alone for several months, you should unplug it and clean it according to the instructions above. Pay special attention to drying the interior.

Now set the unit aside somewhere out of the reach of children. You may want to crack the door slightly to prevent mold growth or odour.

Transporting the Cooler

The ideal packaging for you cooler is its original packaging. If possible, keep this packaging handy and repack the cooler as it was initially packed if you need to transport it.

If you do not have the original packaging:

- Make sure the cooler is turned off and unplugged.
- Remove all items.
- Remove shelves and any other loose items within the cooler.
- Shut the door and tape it closed.
- Transport the cooler in a secure, upright position along with its shelves.
- Protect the outside of the cooler with Styrofoam, cardboard, a blanket, etc.

Energy Efficiency Tips

Locate your cooler in the coolest area of the room.

Locate your cooler away from direct sunlight or any heat-producing sources, as this will force the cooler to work even harder, making it less likely to cool your wine properly.

Let any hot foods or drinks cool before placing them inside the cooler.

5. Troubleshooting

Your EdgeStar wine cooler is a thermoelectric refrigeration unit that uses “green” thermoelectric cooling to store your wine under ideal conditions.

What are the benefits of thermoelectric cooling?

- Low energy usage
- No vibration
- Cools with little noise- the only noise produced is by the fans used to dissipate heat.

What are some of its limitations?

- Cooling takes longer than with equivalent compressor-based units- you must allow 24 hours or more for the unit to reach its lowest temperature
- Fans run constantly
- Units are more sensitive to ambient temperature, sunlight conditions, and potentially loading conditions- they may not cool to their theoretical minimum temperature under adverse conditions

Symptoms	Possible causes	Solutions
The wine cooler does not turn on.	<p>There is a power failure.</p> <p>The cooler is not plugged in.</p> <p>A house fuse has blown or the circuit breaker is tripped.</p>	<p>Ensure the cooler is plugged in and the power outlet has power.</p> <p>Replace the broken fuse in your fuse box or reset the breaker.</p>
The wine cooler will not reach the desired temperature	<p>The cooler is placed too close to a heat source.</p> <p>The cooler does not have sufficient ventilation.</p> <p>The door is opened too frequently or for a long period of time.</p>	<p>Keep the cooler away from sunshine or other heat sources.</p> <p>Make sure the wine cooler has several inches of ventilation on the sides and back.</p> <p>Close the door tightly and do not open the door too frequently or for a long period of time.</p>
Frost is forming in the wine cooler	<p>The environment is humid.</p> <p>The ambient temperature is too low.</p> <p>The door is being opened too frequently.</p>	<p>Though the unit uses an "auto-defrost" system, under certain conditions, manual defrosting may be required. If frost builds up, you can try running the cooler on a warmer temperature setting, minimizing the number of times you open the door, or unplugging the unit to allow the frost to melt.</p>

Symptoms	Possible causes	Solutions
<p>The cooler turns on and off frequently.</p>	<p>The room temperature is higher than the recommended ambient temperature (77°F).</p> <p>The door is being opened often.</p> <p>The door is not completely closed.</p> <p>The door gasket is not sealing properly.</p> <p>The cooler does not have the suggested ventilation.</p>	<p>Run the cooler in the appropriate ambient temperature.</p> <p>Minimize the number of times the door is opened.</p> <p>Make sure the door is completely closed.</p> <p>Make sure the door gasket is properly sealing.</p> <p>Make sure the cooler has at least 2" on the sides and 4" in the back for clearance.</p>
<p>The cooler makes too much noise.</p>	<p>If the noise is from the fan, it may be normal operating noise.</p> <p>The unit is not level.</p> <p>Popping or crackling noises are coming from the unit.</p>	<p>The fan makes normal fan noises when operating- this is normal.</p> <p>Make sure the cooler is on a level surface.</p> <p>Some popping or crackling noises are normal. They are caused by expansion and contraction of the inside walls due to temperature changes.</p>
<p>The door will not shut properly.</p>	<p>Your cooler is not level.</p> <p>The door gasket is dirty.</p> <p>The door gasket is malformed.</p> <p>The shelves are incorrectly installed.</p>	<p>Make sure the cooler is on a level surface.</p> <p>Clean the door gasket.</p> <p>Make sure the door gasket is properly sealing.</p> <p>Correctly install the shelves.</p>

6. Limited Warranty

This EdgeStar product is warranted to be free from defective workmanship and materials for the first year following the date of original purchase. Replacement parts will be supplied free of charge for the first year following the date of original purchase. Labor will be performed free of charge for the first 90 days following the date of original purchase.

WHAT IS COVERED:

This warranty applies to the original purchaser only, and only covers defects in workmanship experienced during operation of the product under normal service, maintenance, and usage conditions. This warranty applies to the purchase and use of this product in residential settings within the United States of America.

WHAT IS NOT COVERED:

The following limitations apply to the coverage of this warranty:

Optional accessories, attachments, and appearance items are excluded from warranty coverage, as is shipping damage, and any damage caused by improper voltage or any other misuse, including abnormal service, handling, or usage.

This warranty does not cover normal wear and tear on parts or replacement of parts designed to be replaced, e.g. filters, etc.

This warranty does not cover service trips to deliver, pick-up, repair, or install the product, or to instruct in proper usage of the product.

Damages or operating problems resulting from abuse, operation outside environmental specifications, uses contrary to instructions provided in the owner's manual, accidents, vermin, fire, flood, improper installation, unauthorized service, acts of God, unauthorized installation or modification, or commercial use are excluded from warranty coverage.

This warranty does not cover labor incurred 91 days or more after the date of original purchase.

This warranty does not cover use of EdgeStar products in commercial settings.

DESCRIPTION OF WARRANTY SERVICE:

All defective product components covered by this warranty will be repaired or replaced, at EdgeStar's option, free of charge on a mail-in basis to EdgeStar's authorized repair facility during the first 90 days from the date of original purchase.

All defective product components covered by this warranty will be repaired or replaced, at EdgeStar's option, on a mail-in basis to EdgeStar's authorized repair facility during the time period beginning on the 91st day from the date of original purchase and ending one year from the date of original purchase. During this time period, parts will be supplied free of charge, but labor charges will apply.

All replacement parts and units will be new, remanufactured, or refurbished. All products and components replaced by EdgeStar under warranty service become the property of EdgeStar.

OBTAINING WARRANTY SERVICE:

Contact EdgeStar for troubleshooting assistance and warranty service authorization at 1-866-319-5473. Please have your order receipt available to confirm the date of purchase.

Once an EdgeStar authorized representative has confirmed that your product is eligible for warranty service, the product must be returned to an EdgeStar authorized repair facility.

The purchaser is solely responsible for prepaying all shipping related costs to and from the repair facility.

EdgeStar is not responsible for damage resulting from shipper mishandling or improper packaging.

Do not return defective product to the place of purchase.

THIS WARRANTY IS IN LIEU OF ANY OTHER WARRANTY, EXPRESS OR IMPLIED, INCLUDING WITHOUT LIMITATION, ANY WARRANTY OF MERCHANTABILITY OR FITNESS FOR A PARTICULAR PURPOSE. TO THE EXTENT ANY IMPLIED WARRANTY IS REQUIRED BY LAW, IT IS LIMITED IN DURATION TO THE EXPRESS WARRANTY PERIOD ABOVE. NEITHER THE MANUFACTURER NOR ITS DISTRIBUTORS SHALL BE LIABLE FOR ANY INCIDENTAL, CONSEQUENTIAL, INDIRECT, SPECIAL, OR PUNITIVE DAMAGES OF ANY NATURE, INCLUDING WITHOUT LIMITATION, LOST REVENUES OR PROFITS, OR ANY OTHER DAMAGE WHETHER BASED IN CONTRACT, TORT, OR OTHERWISE. SOME STATES DO NOT ALLOW THE EXCLUSION OF INCIDENTAL OR CONSEQUENTIAL DAMAGES, SO THE ABOVE EXCLUSION MAY NOT APPLY TO YOU. THIS WARRANTY GIVES YOU SPECIFIC LEGAL RIGHTS. YOU MAY HAVE OTHER RIGHTS THAT VARY FROM STATE TO STATE.