

Operator's Manual

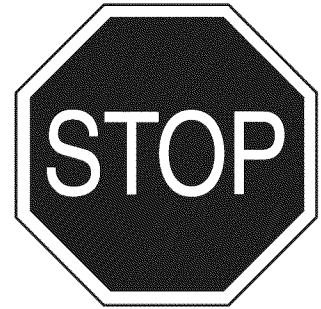

44" HIGH SPEED SWEEPER

Model No. 486.24644

DO NOT RETURN TO STORE
For Missing Parts or Assembly
Questions Call 1-866-576-8388

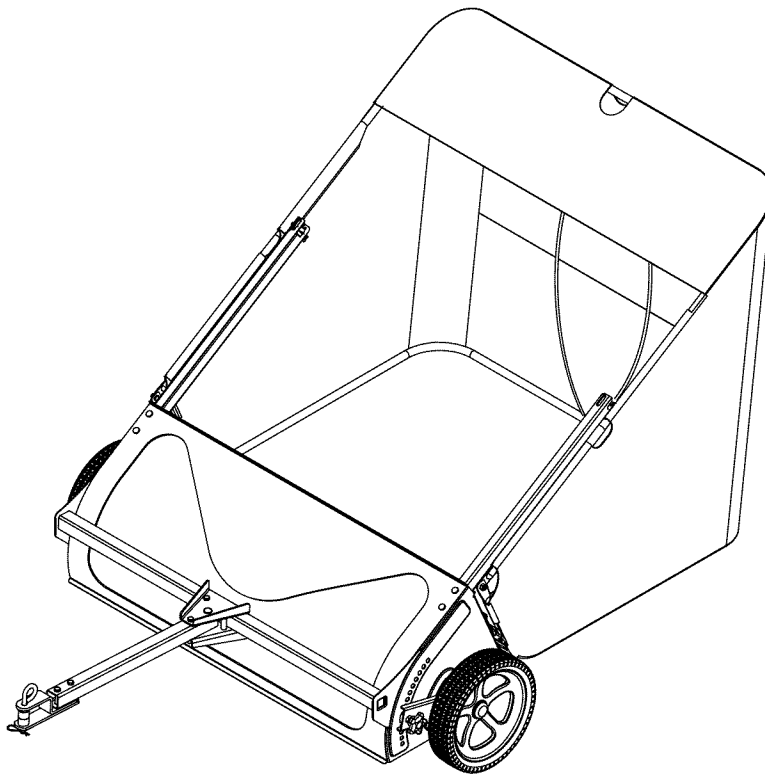

CAUTION:

Before using this product, read this manual and follow all Safety Rules and Operating Instructions.

- Safety
- Assembly
- Operation
- Maintenance
- Parts

Sears Brands Management Corporation, Hoffman Estates, IL 60179 U.S.A.
www.craftsman.com

TABLE OF CONTENTS

WARRANTY	2	MAINTENANCE	11
SAFETY RULES.....	3	STORAGE	11
CARTON CONTENTS.....	3	SERVICE AND ADJUSTMENTS.....	12
HARDWARE PACKAGE	4	NOTES	13
ASSEMBLY.....	5	REPAIR PARTS ILLUSTRATION.....	14
OPERATION.....	10	REPAIR PARTS LIST.....	15
TROUBLESHOOTING.....	11	PARTS ORDERING/SERVICE	BACK PAGE

WARRANTY

CRAFTSMAN ONE YEAR FULL WARRANTY

For one year from the date of purchase, this product is warranted against any defects in material or workmanship. A defective product will be replaced free of charge.

For warranty coverage details to obtain free replacement, visit the web site: www.craftsman.com

This warranty is void if this product is ever used while providing commercial services or if rented to another person.

This warranty gives you specific legal rights, and you may also have other rights which vary from state to state.

Sears Brands Management Corporation, Hoffman Estates, IL 60179

The model number and serial numbers will be found on a decal attached to the 44" High Speed Sweeper. You should record both the serial number and the date of purchase and keep in a safe place for future reference.	MODEL NUMBER:	486.24644
	SERIAL NUMBER:	_____
	DATE OF PURCHASE:	_____



SAFETY RULES



Remember, any power equipment can cause injury if operated improperly or if the user does not understand how to operate the equipment. Exercise caution at all times when using power equipment.

- Read the vehicle and sweeper owners manuals and know how to operate your vehicle and sweeper before using this sweeper attachment. Always instruct other users before they operate the sweeper.
- Vehicle braking and stability may be affected with the addition of an accessory or an attachment. Be aware of changing conditions on slopes.
- Do not permit children to operate sweeper.
- Do not permit anyone to ride on sweeper.
- Operate the sweeper at reduced speed on rough terrain, near ditches and on hillsides to prevent loss of control.
- Vehicle braking and stability may be affected with attachment of this sweeper. Do not fill sweeper to maximum capacity without checking capability of the towing vehicle to safely pull and stop with the sweeper attached. Stay off of steep slopes
- Do not exceed 6 m.p.h. Driving too fast may cause damage to sweeper's wheels and bearings.
- Do not hold onto dump handle while tractor is moving.
- Never attach dump handle to tractor or any part of your body. Always keep it secured to the hopper bag while tractor is moving. If any part of dump handle should become damaged, stop use of sweeper and replace the damaged part.
- Stop and inspect vehicle and sweeper for damage after striking an object. Repair any damage before continuing operation.
- Keep sweeper away from fire. Excessive heat can damage the brushes and hopper bag and could cause the bag and its contents to burn.
- Before storing the sweeper, always empty the hopper bag to avoid spontaneous combustion.
- Follow maintenance and lubrication instructions as outlined in the maintenance section of this manual.



Look for this symbol to point out important safety precautions. It means — **Attention! Become alert! Your safety is involved.**

CARTON CONTENTS

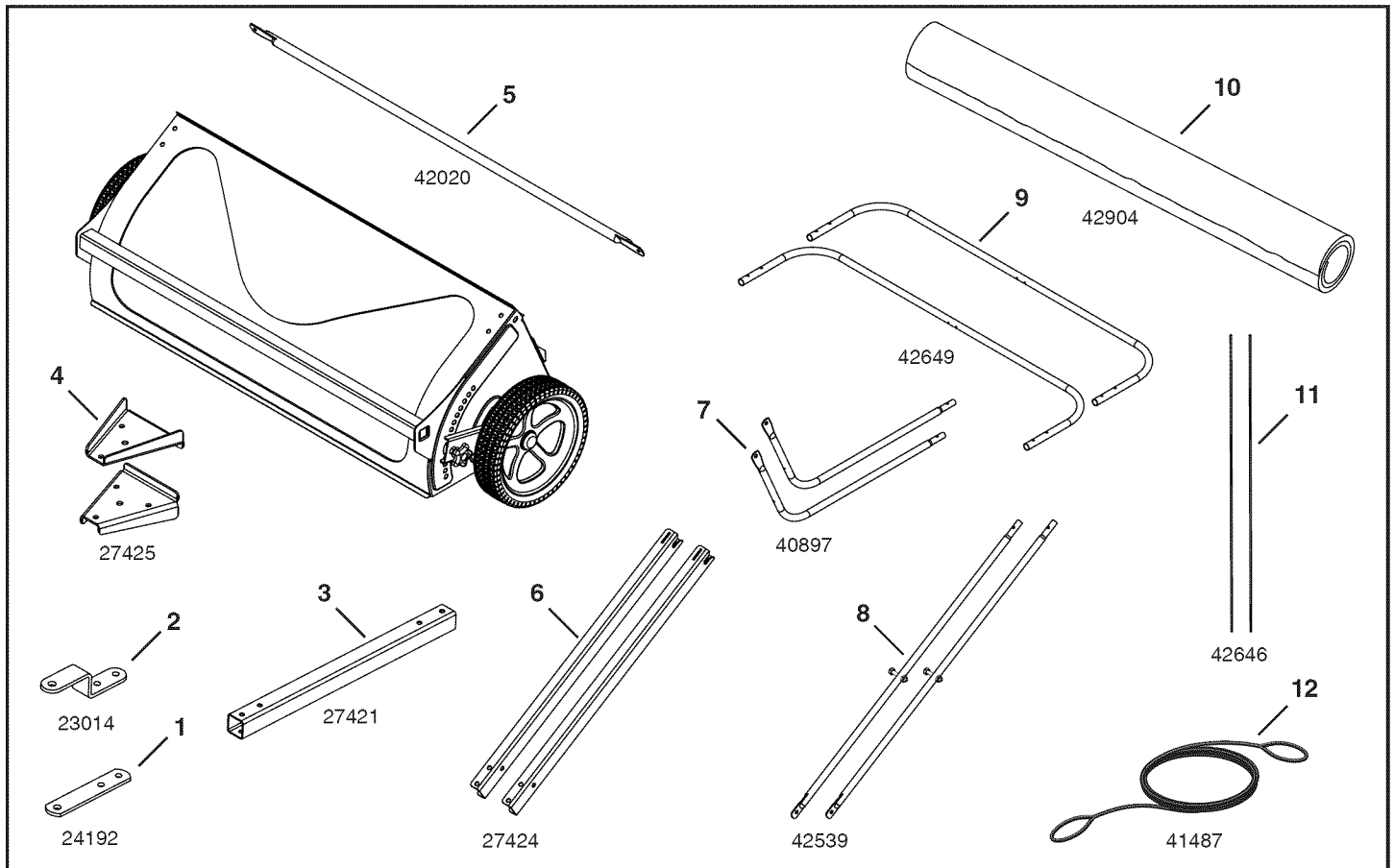

HARDWARE PACKAGE

SHOWN FULL SIZE

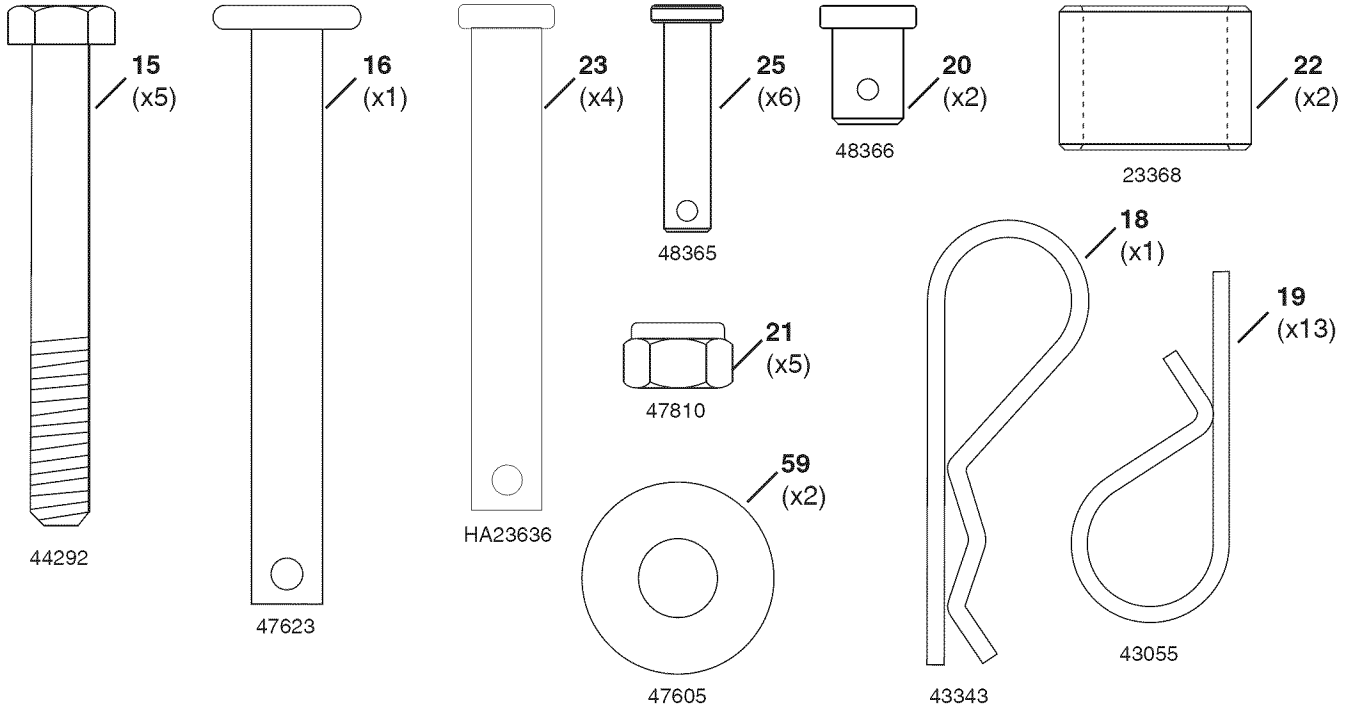

NOT SHOWN FULL SIZE

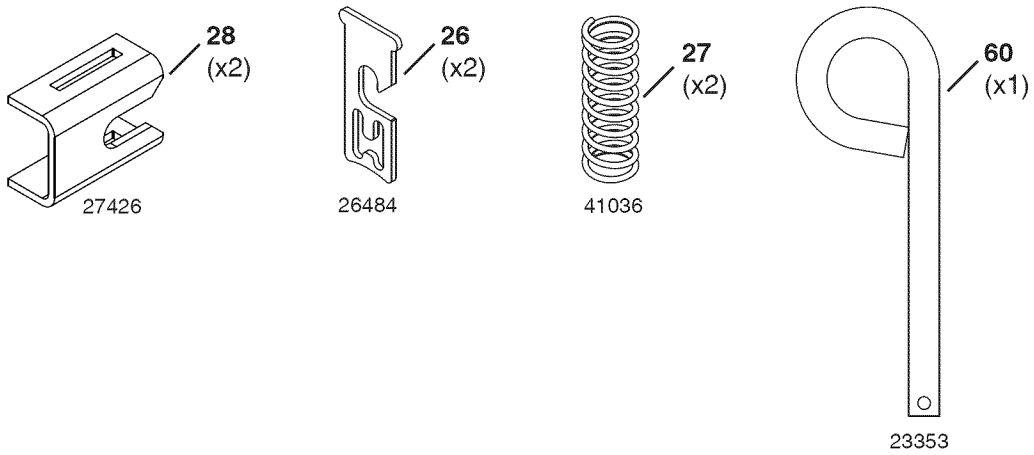

ASSEMBLY

TOOLS REQUIRED FOR ASSEMBLY

- (2) 7/16" Wrenches
- (2) 1/2" Wrench
- (1) Pliers
- (1) Hammer

STEP 1: (SEE FIGURE 1)

- Secure each bag arm channel (6) to the sweeper housing using two 3/8" x 2-1/4" clevis pins (23) and two small hairpin cotters (19).

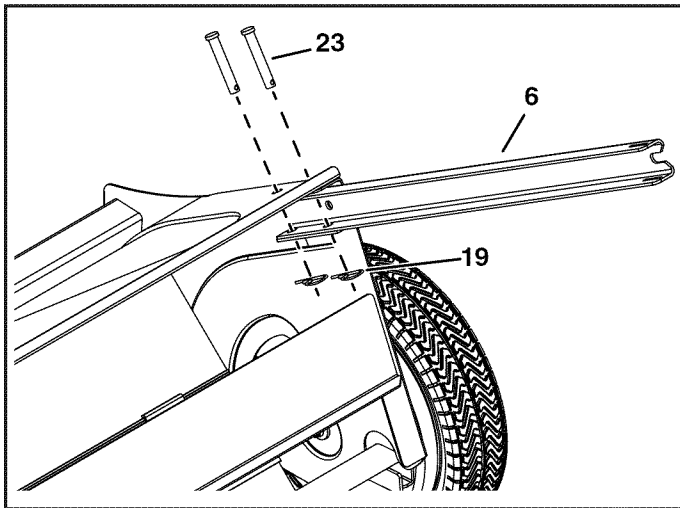

FIGURE 1

STEP 2: (SEE FIGURE 2)

- Place a pivot rod support bracket (28) in the end of a bag arm channel and then insert a pivot rod retainer (26) down into the slots in the bracket and the channel. Repeat for the other bag arm channel.

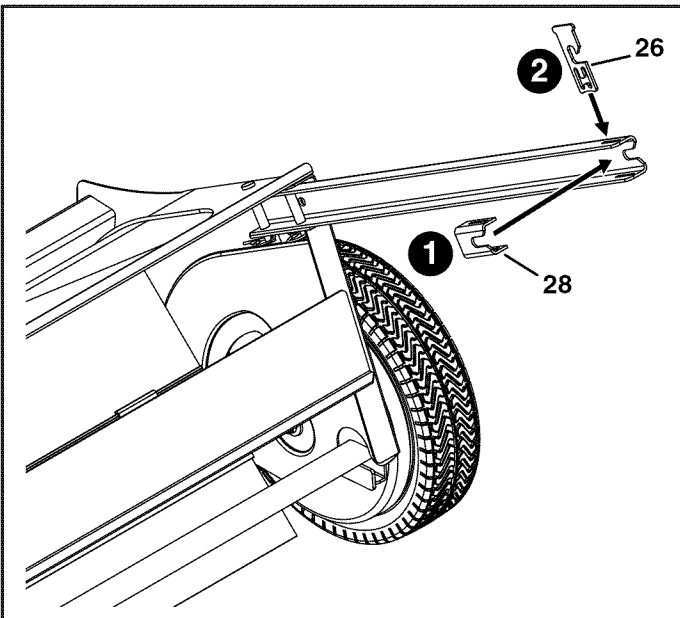

FIGURE 2

STEP 3: (SEE FIGURE 3)

- Install a compression spring (27) into the bottom of each of the pivot rod retainers, securing them to the bag arm channels.

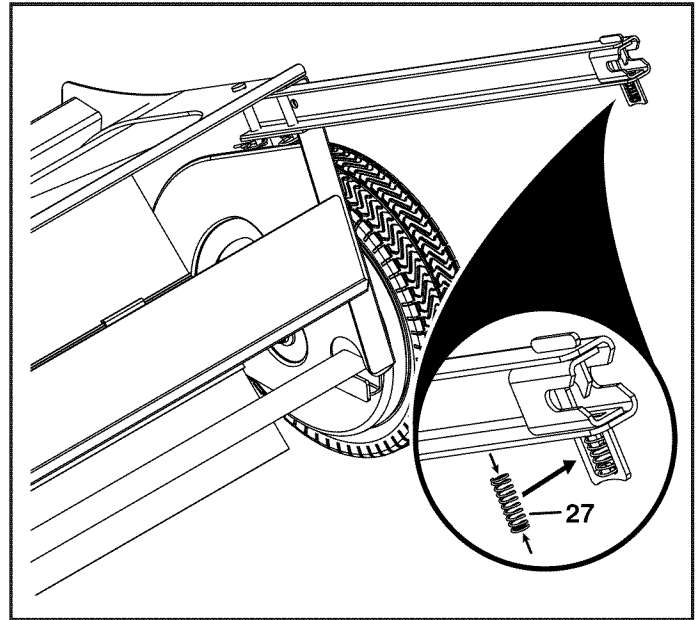

FIGURE 3

STEP 4: (SEE FIGURE 4)

- Attach the drawbar brackets (4) to the drawbar (3) using one 5/16" x 2-1/2" hex bolt (15), two washers (59), and one 5/16" nylock nut (21). Make the nut finger tight only.
- Insert the 3/8" x 3" pin (16) into the brackets and drawbar and install a small hairpin cotter (19).

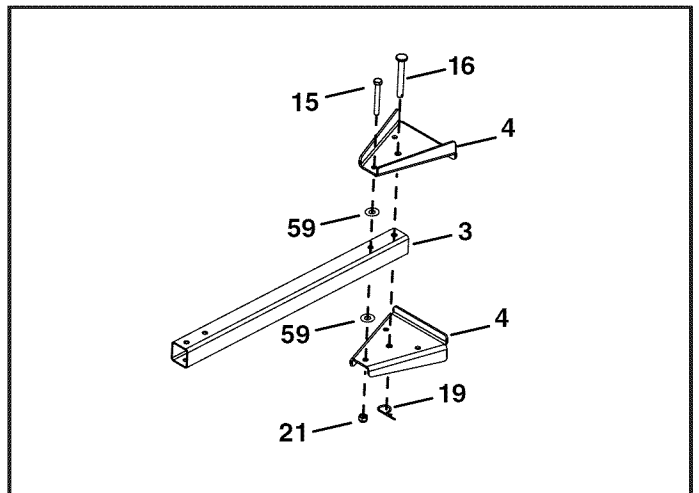

FIGURE 4

STEP 5: (SEE FIGURE 5)

- Attach the drawbar and brackets to the sweeper using two 5/16" x 2-12" hex bolts (15) and two 5/16" nylock nuts (21). Tighten all three bolts installed in the brackets, then loosen the front bolt by 1/4 to 1/2 turn.

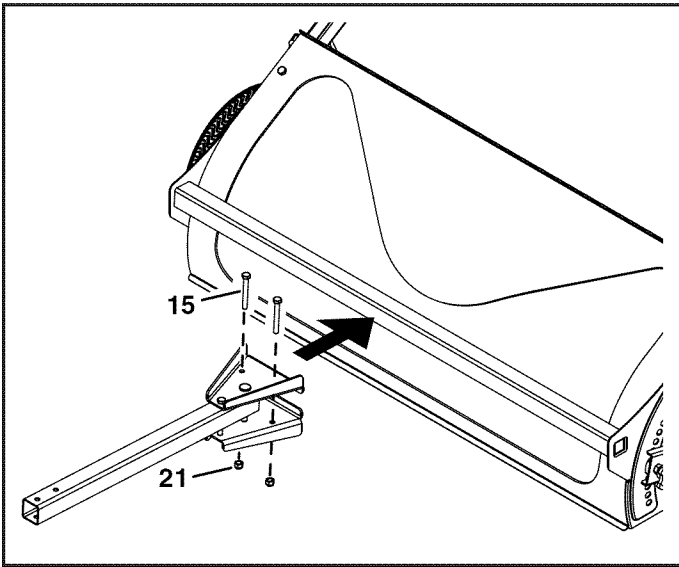

FIGURE 5

STEP 7: (SEE FIGURE 7)

- Install a rear hopper tube (9) onto the ends of the two lower hopper tubes (7). Secure them with two 1/4 x 1.11" clevis pins (25) and small hairpin cotters (19).

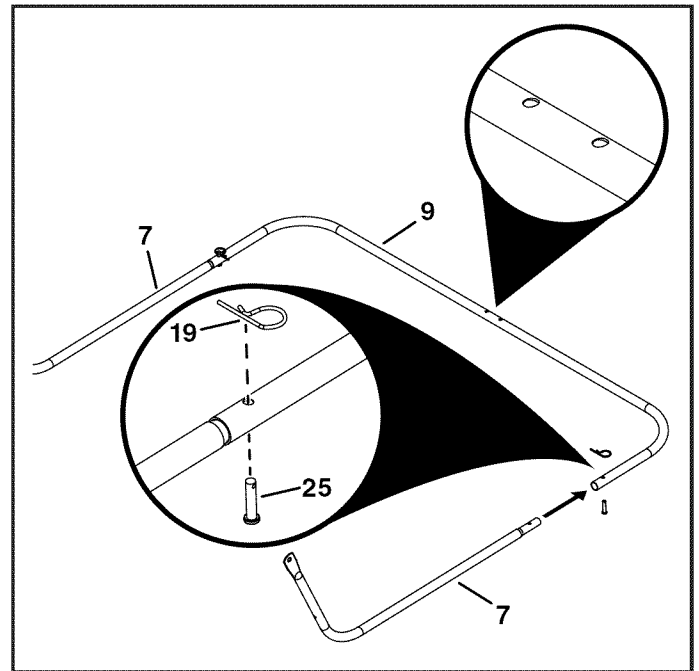

FIGURE 7

STEP 6: (SEE FIGURE 6)

- Measure the distance from the tractor hitch to the ground. Arrange the hitch brackets as shown according to your tractor's hitch height.
- Attach the bent hitch bracket (2) and straight hitch bracket (1) to the drawbar using two 5/16" x 2-1/2" hex bolts (15) and 5/16" nylock nuts (21).
- Assemble the hitch pin (60) and two 3/4" spacers (22) to the hitch brackets. Secure them in place with a large hairpin cotter (18).

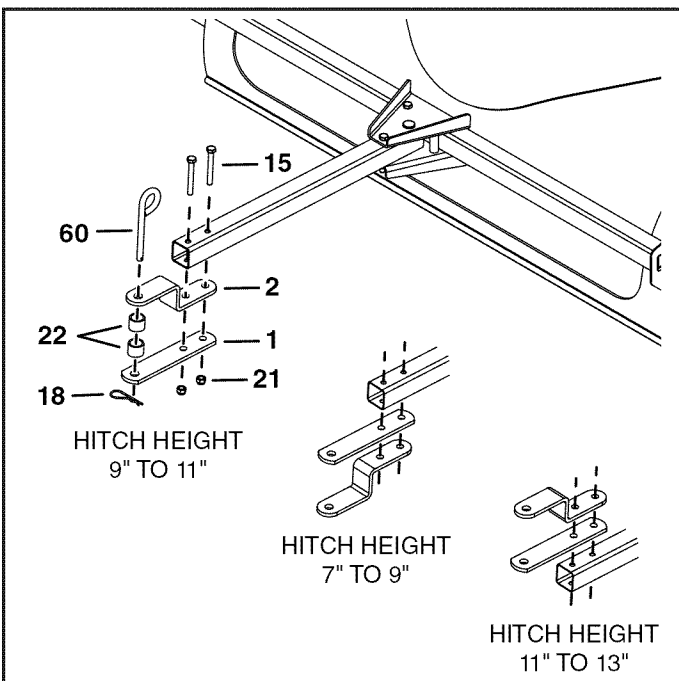

FIGURE 6

STEP 8: (SEE FIGURE 8)

- Install a rear hopper tube (9) onto the ends of the two upper hopper tubes (8). Secure them with two 1/4 x 1.11" clevis pins (25) and small hairpin cotters (19).

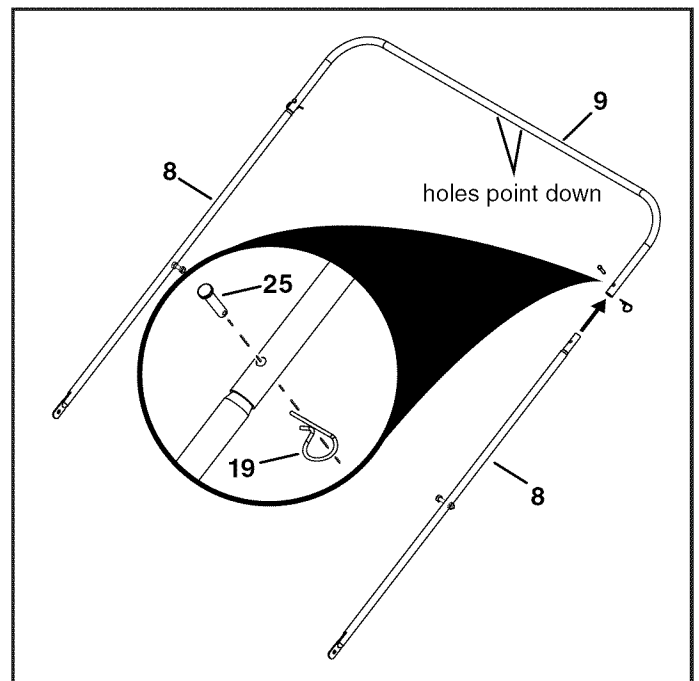

FIGURE 8

STEP 9: (SEE FIGURE 9)

- Attach the upper and lower hopper tubes together using two 3/8 x 1/2" clevis pins (20) and small hairpin cotters (19).

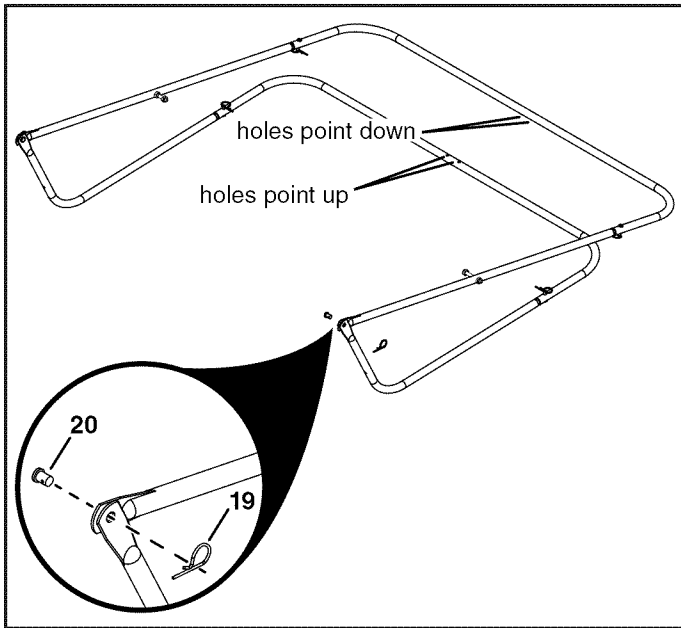

FIGURE 9

STEP 11: (SEE FIGURE 11)

- Slide the bag frame tube (1) through the front flap of the hopper bag.

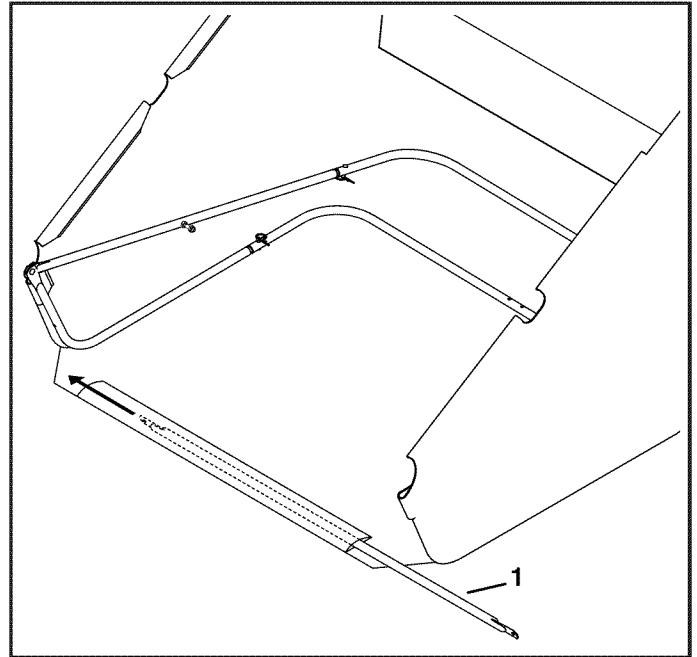

FIGURE 11

STEP 10: (SEE FIGURE 10)

- Slide the hopper tubes into the hopper bag.

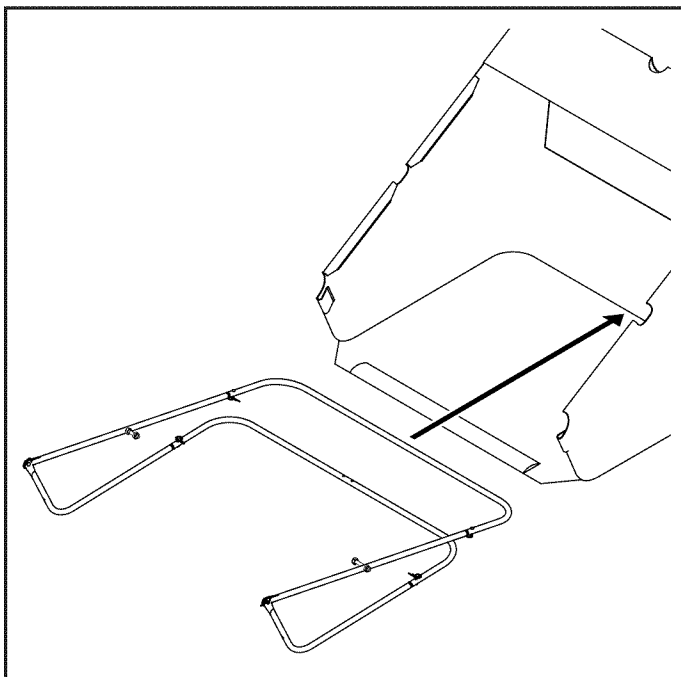

FIGURE 10

STEP 12: (SEE FIGURE 12)

- Insert the hopper support rods (11) into the holes of the upper hopper tube. Then, flex and insert the rods into the holes in the bottom rear hopper tubes.

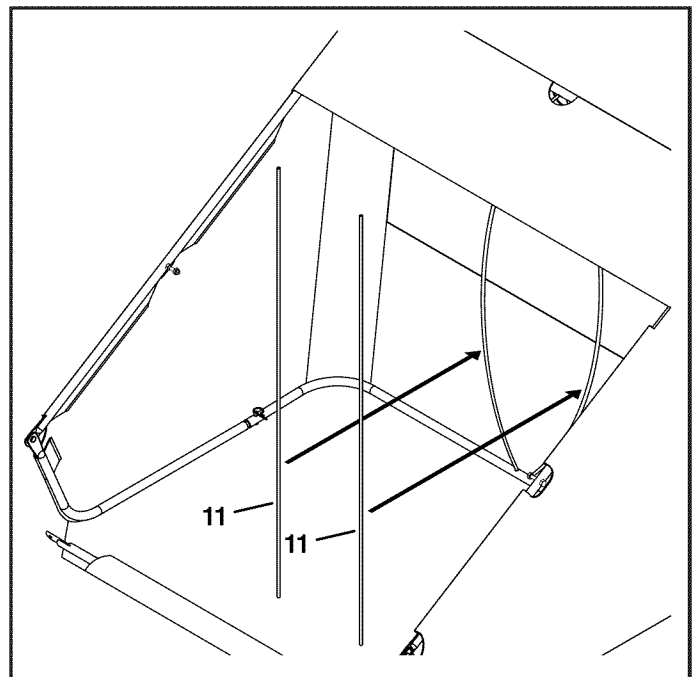

FIGURE 12

STEP 13: (SEE FIGURE 13)

- Secure the bag frame tube to the lower hopper tubes using two 1/4 x 1.11" clevis pins (25) and small hairpin cotters (19).

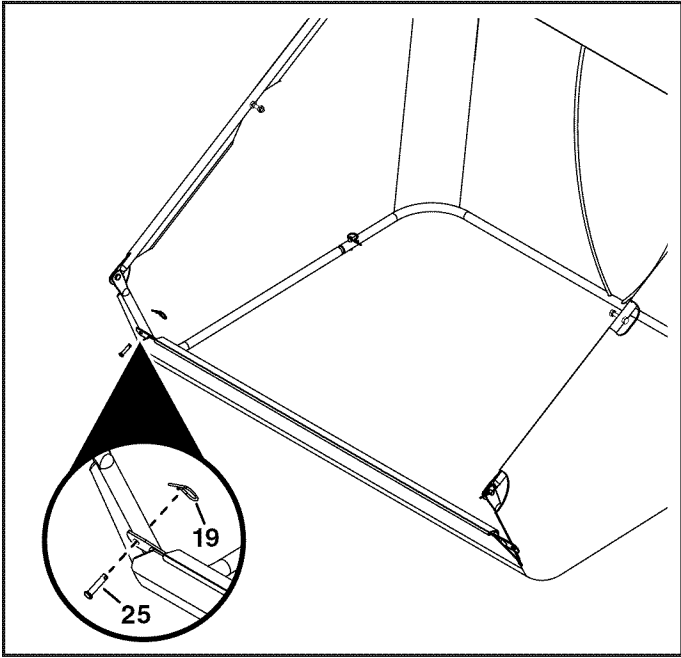

FIGURE 13

STEP 15: (SEE FIGURE 15)

- Starting from the front of the bag, secure the hopper bag to the bag frame using the velcro flaps.

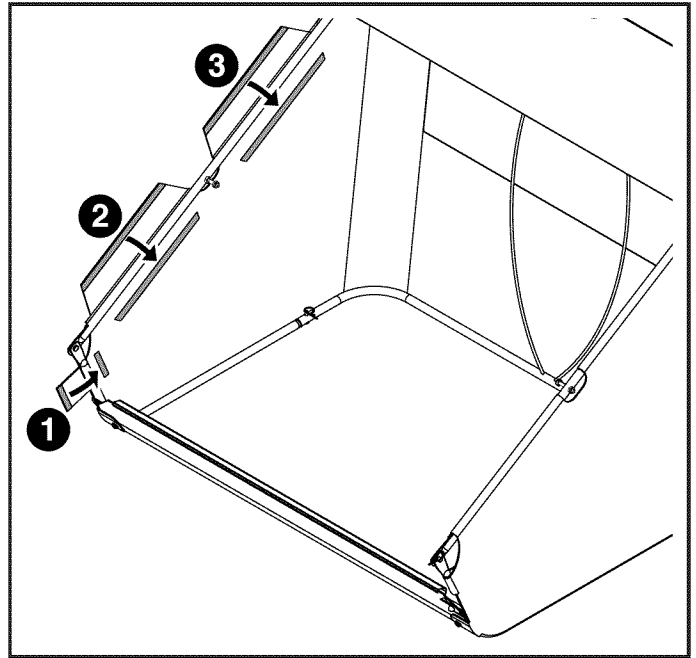

FIGURE 15

STEP 14: (SEE FIGURE 14)

- Open up all the flaps on the hopper bag.
- Snap the lower front flaps of the hopper bag to the front of the hopper bag bottom.

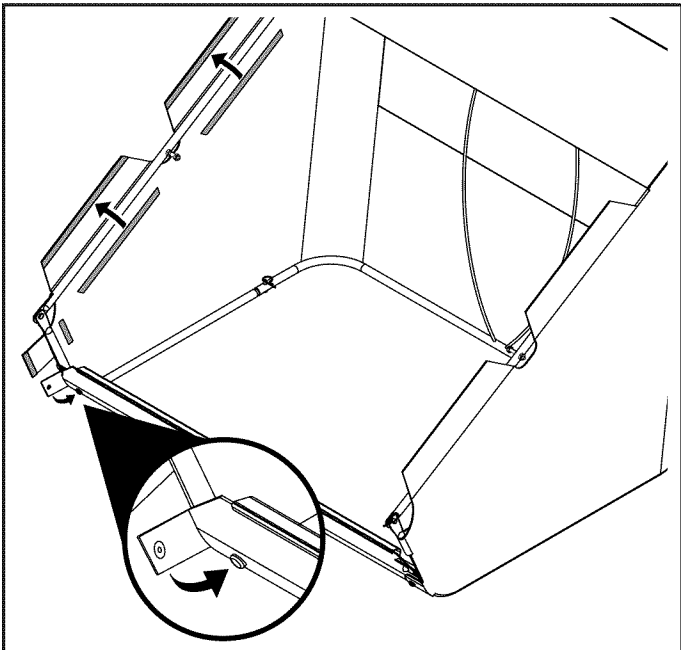

FIGURE 14

STEP 16: (SEE FIGURE 16)

- Tie the four tie straps tightly around the upper rear hopper tube.

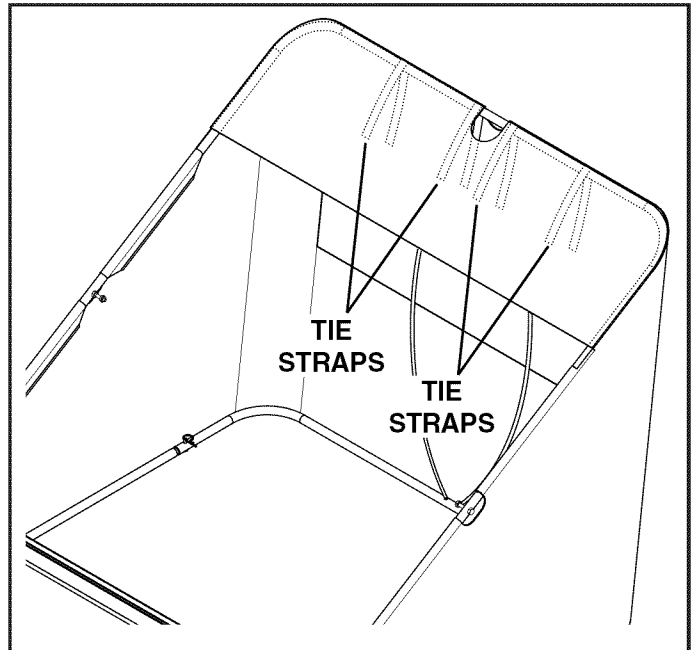

FIGURE 16

STEP 17: (SEE FIGURE 17)

- Attach the rope (12) to the center of the upper rear hopper tube.

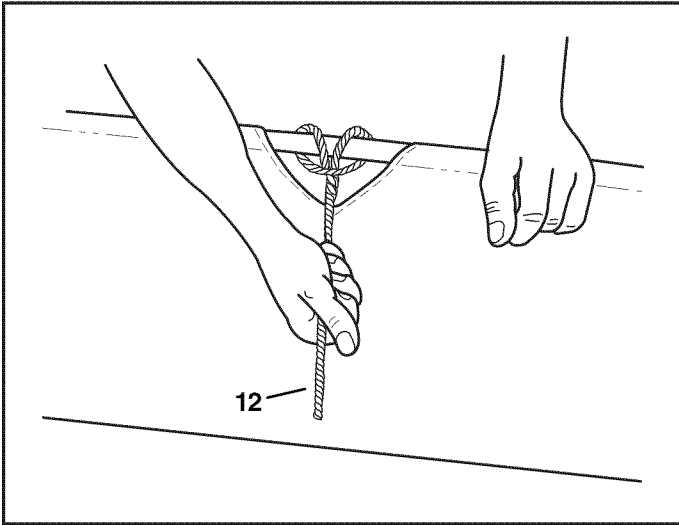

FIGURE 17

STEP 18 (SEE FIGURE 18)

- Attach the hopper bag to the sweeper by sliding the pivot bolts in the hopper tubes into the pivot rod retainers in the ends of the bag arm channels.

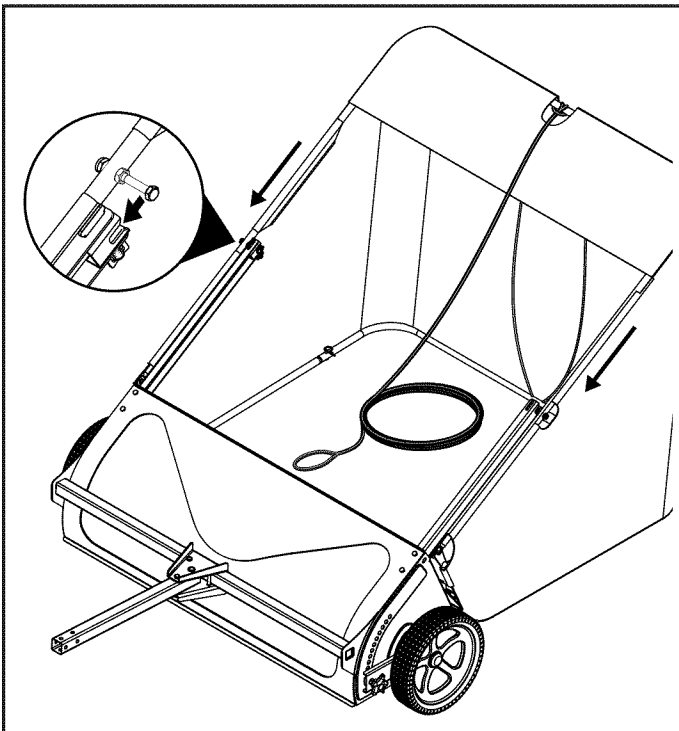

FIGURE 18

ATTACHING SWEEPER HITCH TO TRACTOR

1. Place the tractor and sweeper on a flat level surface.
2. Set the sweeper height adjustment to about the middle of the adjustment range.
3. Attach the sweeper hitch to the tractor hitch, arranging the hitch brackets according to the drawbar height of your tractor as shown in figure 20 below and in figure 6 on page 6.
4. Arrange the spacers into one of the three possible combinations as shown below in figure 20.

IMPORTANT: To obtain the best performance from your sweeper, arrange the spacers so that the sweeper bag is approximately level with the ground as shown in figure 19.

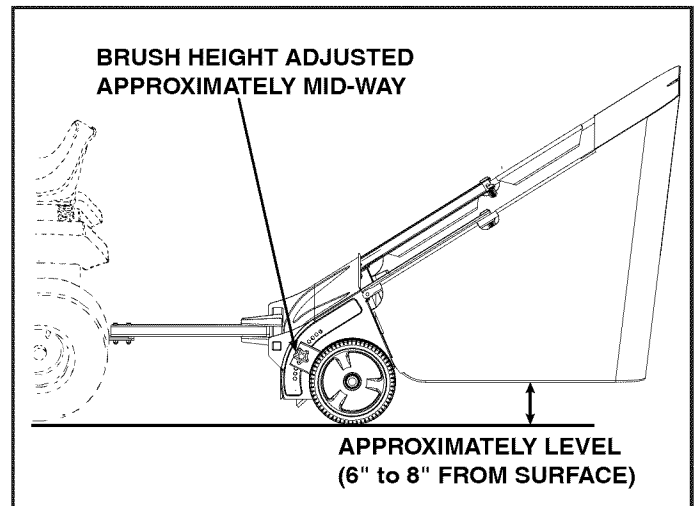

FIGURE 19

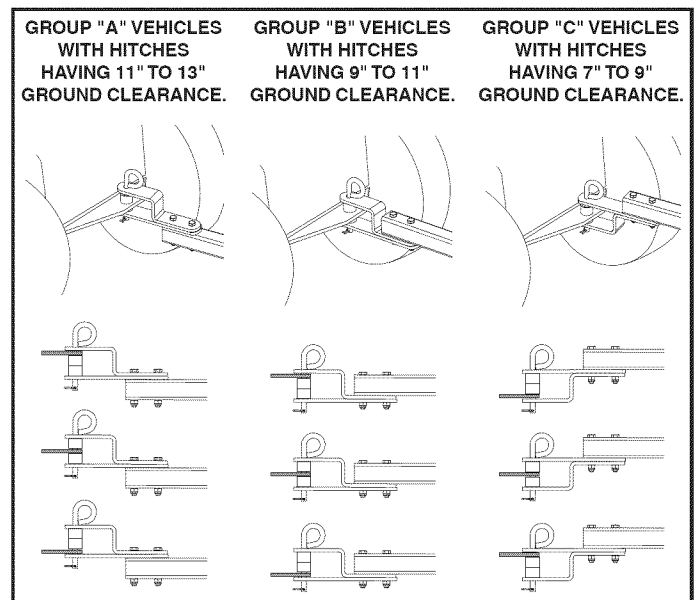
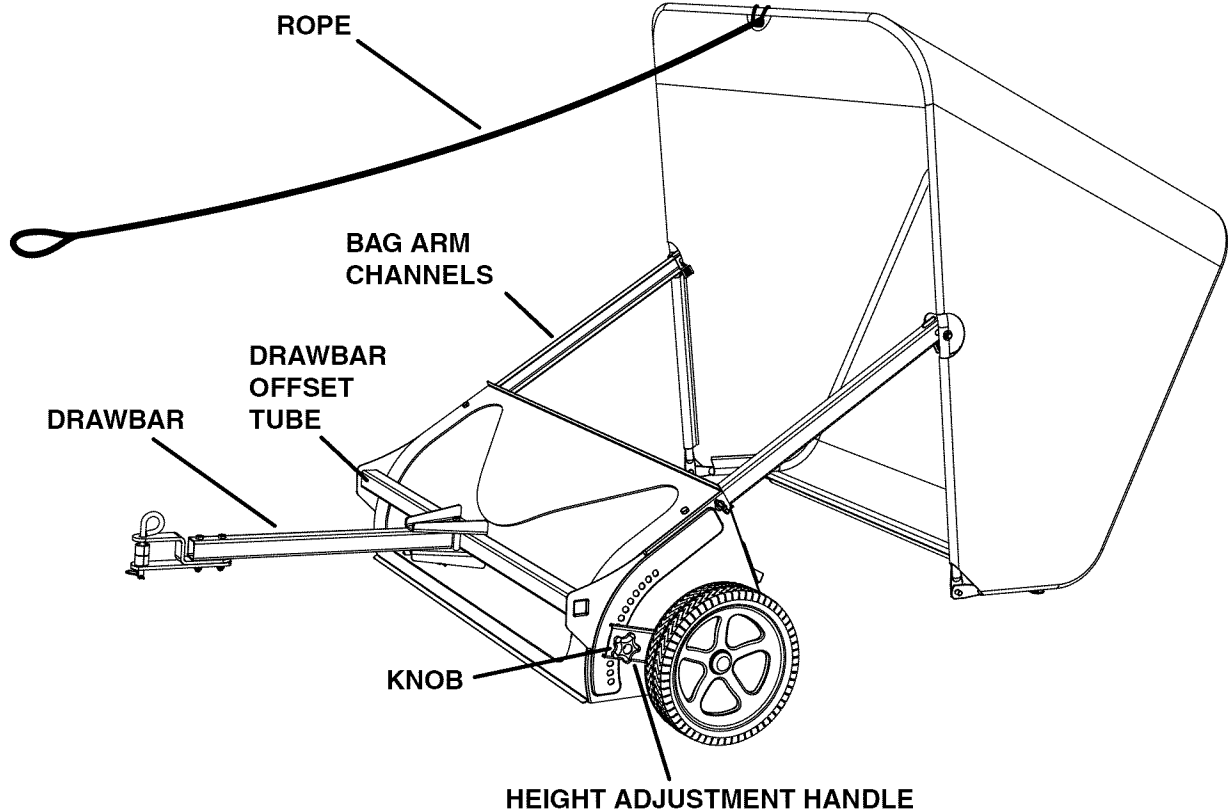

FIGURE 20

OPERATION

(SWEEPER SHOWN IN DUMP POSITION)



Dump Rope

Permits dumping of the hopper bag from the driver's seat.

Bag Arm Channels

Connects the hopper bag to the sweeper housing.

Height Adjustment Handle

Adjusts the operating height of the sweeper.

Knob

Locks the height adjustment handle into a height adjustment hole.

Drawbar

Connects the sweeper to the towing vehicle. Adjusts for various height tractor hitches.

Drawbar Offset Tube

Allows the sweeper to be offset behind the tractor.

HOW TO USE YOUR SWEEPER



CAUTION: Maximum towing speed is 6 m.p.h. Driving too fast may cause damage to wheels and bearings.

BRUSH HEIGHT ADJUSTMENT

- To adjust sweeper brushes to best operating height, loosen adjustment knob and lift up on height adjustment lever to raise the brush, or push down on the lever to lower the brush. See figure above. Best adjustment is when the brush setting is 1/2" down into the grass. Always mow the grass to an even height before sweeping.

DRAWBAR OFFSET

The drawbar can be positioned at the center, or at the left hand or right hand end of the drawbar offset tube.

SWEEPING SPEED

- Do not exceed 6 m.p.h.** Try a starting speed of approximately 3 m.p.h. (third gear on most tractors). Depending on conditions, it may be necessary to adjust the sweeping speed in order to achieve best results.

DUMPING OF SWEEPER

- Your sweeper can be dumped without getting off of the rider or tractor. Pull forward on the rope to empty the hopper. Always empty hopper after each use.



CAUTION: Keep sweeper away from fire. Excessive heat can damage the brushes and hopper bag and could cause the bag and its contents to burn.

MAINTENANCE

CUSTOMER RESPONSIBILITIES

Read and follow the maintenance schedule and the procedures listed in the maintenance section.

MAINTENANCE SCHEDULE Fill in dates as you complete regular service.	Service Dates											
	Before each use	After each use	Twice a year	Every year	Before storage							
Check for loose fasteners	X											
Check for worn or damaged parts	X			X								
Lubricate brush shaft bearings			X									
Lubricate wheel bearings				X								
Clean Sweeper		X			X							
Clean, inspect and lubricate gears				X								

SCHEDULED MAINTENANCE

- Clean the sweeper after each use.
- Inspect for worn or damaged parts, such as brushes and wheels.
- Every year, remove the wheels to clean and lubricate the gears, wheels and axles. After cleaning, lubricate the axles and the teeth on the gears and wheels with a light coat of grease. To remove a wheel, pop off the hub cap to expose the head of the bolt. Remove the nut and step spacer from the bolt and then remove the wheel along with the bolt and washers. When re-assembling, be sure the step spacer is properly seated in the hole in the sweeper housing. Refer to "Gear and Drive Pin Service" and figure 22 on page 12.

CLEANING

- Clean the sweeper housing with a soft brush or cloth.
- Clean debris from the hopper bag with a brush or broom.
- Remove any material which has wrapped around the brushes or the ends of the brush shaft.

TROUBLESHOOTING

Wheels skid when sweeping	<ul style="list-style-type: none"> • Brushes set too low. • Brushes are jammed. • Wheels are jammed. 	<ul style="list-style-type: none"> • Adjust height till brushes are 1/2" down into grass. • Stop sweeper. Remove obstruction. • Remove one wheel at a time to check for obstruction or damage. Refer to Service and Adjustments section.
----------------------------------	---	---

STORAGE



CAUTION: Before storing the sweeper, always empty hopper bag to avoid spontaneous combustion.

- Clean the sweeper and hopper bag thoroughly to help prevent rust and mildew.
- To collapse the hopper bag for storage, remove the two hopper support rods from the rear of the hopper.

- Remove the pin (16) from the center hole in the drawbar brackets, fold the draw bar and then replace the pin (16). Refer to figure 4 on page 5.
- Remove the rear clevis pins (23) from the bag arm channels and sweeper housing. Fold the bag arm channels into the sweeper housing and replace the clevis pins (23). Refer to figure 1 on page 5.
- Store in a dry area.

SERVICE AND ADJUSTMENTS

BRUSH REPLACEMENT

NOTE: Replace brushes one brush at a time.

1. Remove the hopper bag from the sweeper.
2. Loosen hex bolts and lock nuts on two single brush retainers which clamp one brush to the double brush retainers. **DO NOT** loosen or remove bolts which fasten double brush retainers to brush shaft.
3. Slide the brush out of the retainers, noting on which side of the brush the bristles overlap.
4. Install new brush, making sure the bristles overlap on the same side of the brush as before.

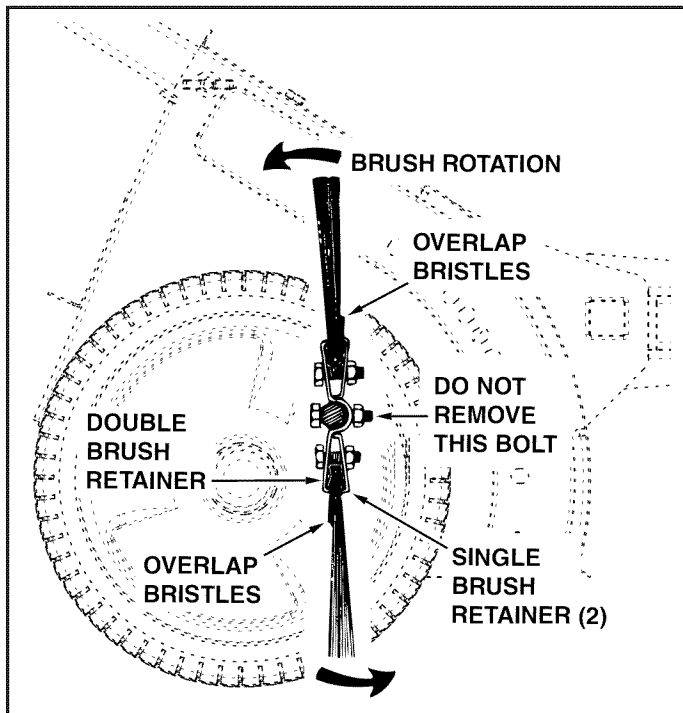

FIGURE 21

GEAR AND DRIVE PIN SERVICE

IMPORTANT: Do Not remove both wheels at the same time to avoid mixing of parts. (The pinion gears are not interchangeable. The ratchet end of the gears is marked "R" or "L".) Make notes on the position of all parts before removing them.

- Remove the hub cap to expose the head of the bolt.
- Remove the bolt, washer, nut and step spacer.
- Remove the wheel and washer from the axle.
- To remove the larger 27 tooth gear, remove the retaining ring and then remove the gear and washers.
- To remove the smaller pinion gear, remove the retaining ring and then remove the gear, the drive pin (located in the brush shaft), the washers and the spacer. See figure 22.
- Clean all parts and replace worn parts.
- Lightly grease the shafts and the axle.
- Lightly grease the drive pin and the ratchet teeth inside the pinion gear. Reassemble the drive pin, pinion gear, the 27 tooth gear and the washers onto the shafts. Lightly grease the teeth of both gears.
- Lightly grease the gear teeth on the wheel and then reassemble the wheel, bolt and washers. Assemble the step spacer and nut onto the bolt, fitting the small end of the spacer into the sweeper housing. Tighten the nut securely.
- Repeat on the other end of the sweeper.
- Check that the brushes rotate only during forward motion of the sweeper. If the brushes are driven in both forward and reverse, the drive pin is jamming. If the brushes are driven only in reverse, the pinion gears have been switched.

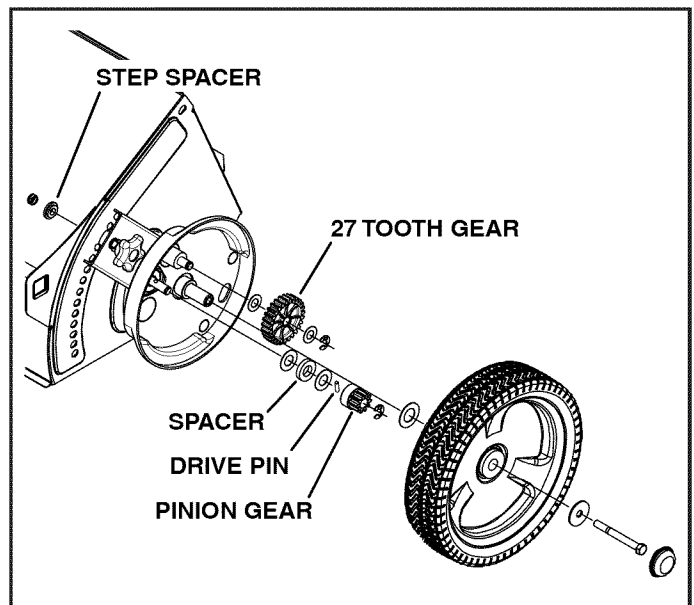

FIGURE 22

NOTES

REPAIR PARTS

486.24644 44" HIGH SPEED SWEEPER

To order replacement parts, call Sears Parts Direct 1-800-252-1698
or go to www.searspartsdirect.com

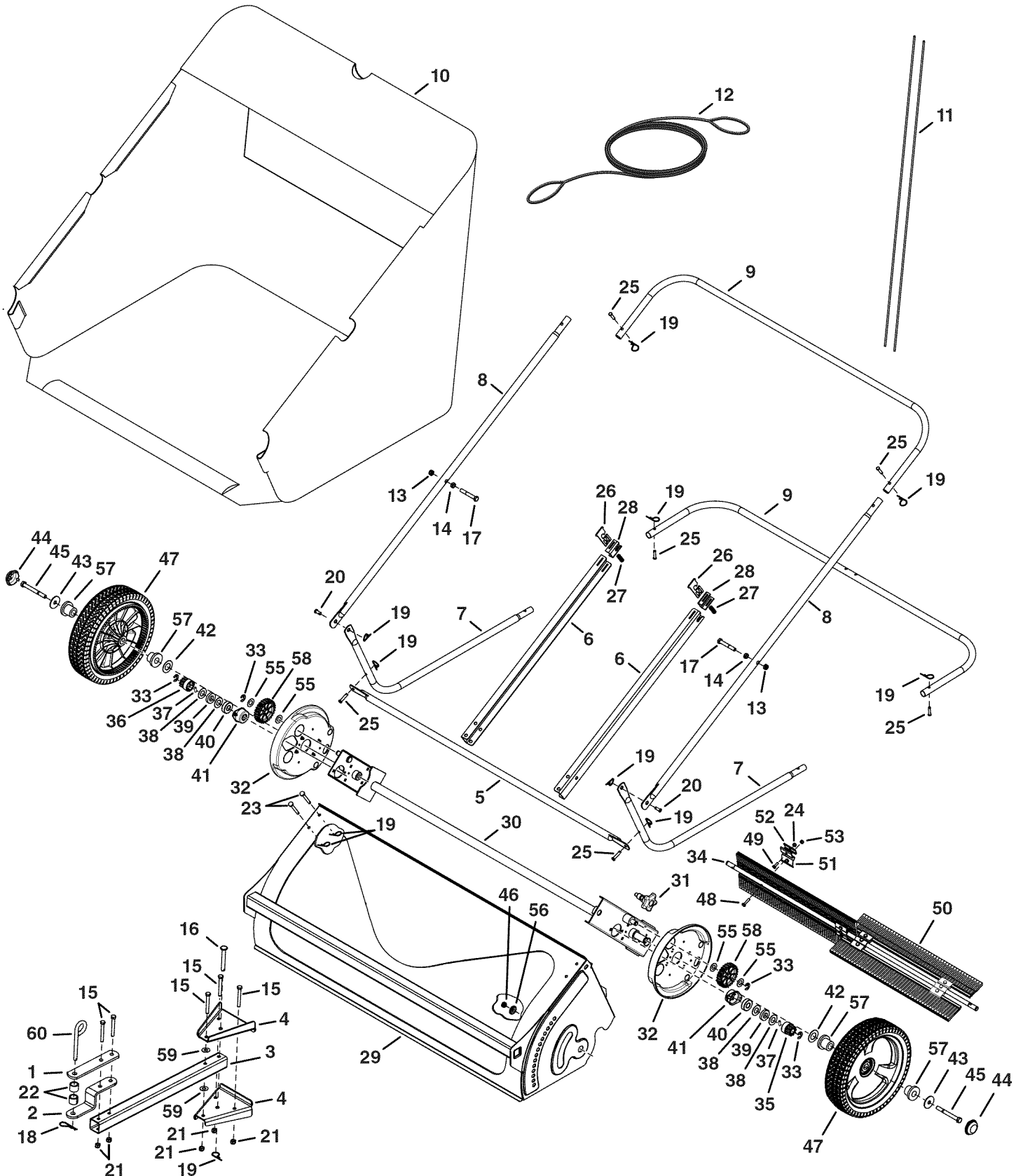

REPAIR PARTS

486.24644 44" HIGH SPEED SWEEPER

To order replacement parts, call Sears Parts Direct 1-800-252-1698 or go to www.searspartsdirect.com

REF	QTY	PART NO	DESCRIPTION	REF	QTY	PART NO	DESCRIPTION
1	1	24192	Straight Hitch Bracket	32	2	41570	Dust Cover
2	1	23014	Hitch Bracket	33	4	1650-1	Retaining Ring (E Type)
3	1	27421	Drawbar	34	1	27257	44" Brush Shaft
4	2	27425	Drawbar Bracket	35	1	48651	Gear, Pinion L.H.
5	1	42020	Bag Frame Tube	36	1	48652	Gear, Pinion R.H.
6	2	27424	Bag Arm Channel	37	2	47046	Dowel Pin, 1/4 x 3/4"
7	2	40897	Lower Hopper Tube	38	4	R19212016	Washer, .656" x 1.25" x .059"
8	2	42539	Upper Hopper Tube	39	2	23520	Spacer, .660" x 1.250" x .250"
9	2	42649	Rear Hopper Tube	40	2	44232	Ball Bearing
10	1	42904	Hopper Bag	41	2	41437	Retainer, Bearing (Plastic)
11	2	42646	Hopper Support Rod	42	2	44008	Washer, .78" x 1.125" x .025"
12	1	41487	Rope	43	2	141	Washer, .378" x 1.25" x .061"
13	2	42210	Hex Nut, 3/8-16 Jam Nylock	44	2	41017	Hub Cap
14	2	712-3008	Hex Nut, 3/8-16 Jam	45	2	43932	Hex Bolt, 3/8-24 x 3-1/2"
15	5	44292	Hex Bolt, 5/16-18 x 2-1/2"	46	2	1038	Nylock Jam Nut, 3/8-24
16	1	47623	Clevis Pin, 3/8" x 3"	47	2	41948	Wheel
17	2	43432	Hex Bolt, 3/8-16" x 2-1/2"	48	4	49954	Socket Screw, #10-32 x 1"
18	1	43343	Hairpin Cotter, 3/32" x 2-5/16"	49	8	43012	Hex Bolt, 1/4-20 x 3/4"
19	13	43055	Hairpin Cotter, 3/32" x 1.8"	50	4	46780	Sweeper Brush
20	2	48366	Clevis Pin, 3/8-16" x 1/2"	51	4	23580	Brush Retainer (Double)
21	5	47810	Nylock Nut, 5/16-18	52	8	23581	Brush Retainer (Single)
22	2	23368	Spacer, .76" x 1" x .76"	53	4	47171	Nylock Nut, #10-32
23	4	HA23636	Clevis Pin, 3/8" x 2-1/4"	54	4	C-9M5732	Pop Rivet (Not Shown)
24	8	47189	Nylock Nut, 1/4"	55	4	44137	Washer, .518" x 1" x .02"
25	6	48365	Clevis Pin, 1/4" x 1.11"	56	2	26538	Step Spacer, .41" x .75"
26	2	26484	Rod Retainer	57	4	45088	Wheel Bearing
27	2	41036	Compression Spring	58	2	41434	Gear, 27 Tooth
28	2	27426	Pivot Rod Support Bracket	59	2	47605	Washer, 411" x 1" x .03"
29	1	67634	Sweeper Housing	60	1	23353	Hitch Pin
30	1	67333	Height Adjustment Tube		1	42889	Owners Manual
31	1	40891	Height Adjustment Knob				

CRAFTSMAN®

Product questions or problems?

1-888-331-4569

Customer Care Hot Line

**Get answers to questions, troubleshoot problems,
order parts, or schedule repair service.**

Para respuestas a preguntas o problemas, y ordenar
piezas o pedir servicio para la reparación de su equipo.

To help us help you, register your product at www.craftsman.com/registration

Para poderte ayudar mejor, registra tu producto en www.craftsman.com/registration

Join the Craftsman Club today!

CRAFTSMAN® CLUB

www.craftsman.com/signup

**Receive exclusive member benefits including special pricing and offers,
project sharing, expert advice, and SHOP YOUR WAY REWARDS!**

Como miembro exclusivo, recibe diversos beneficios como ofertas, precios especiales, proyectos nuevos, consejos de expertos y nuestro programa de puntos SHOP YOUR WAY REWARDS!