

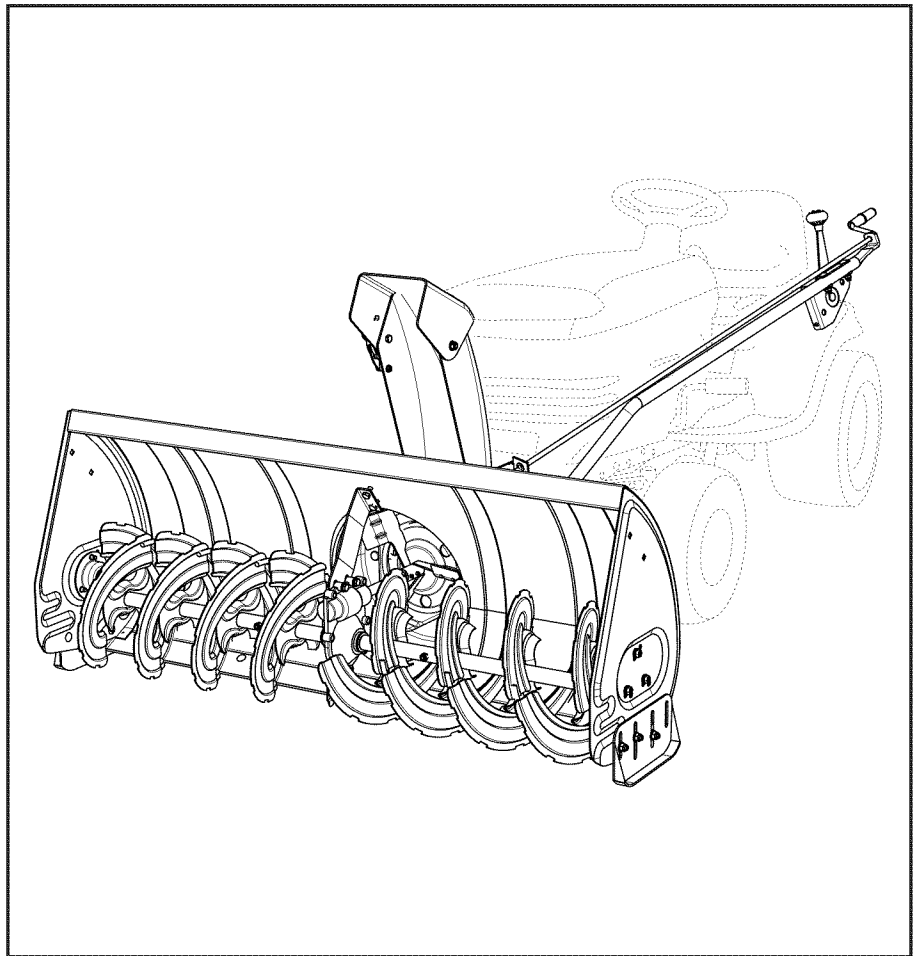

# OWNERS MANUAL

**Model No.  
45-0491**

**CAUTION:**  
Read Rules for  
Safe Operation  
and Instructions  
Carefully



## 50" SNOW THROWER

- Safety
- Assembly
- Operation
- Maintenance
- Parts



Want more information or assembly tips?  
Scan with free ShowUHow Mobile App  
available at iTunes Store or Google Play.

**SpeedPart** *the fastest way to purchase parts* [www.speedepart.com](http://www.speedepart.com)

# TABLE OF CONTENTS

ACCESSORIES.....	2	SERVICE AND ADJUSTMENTS.....	20
SAFETY RULES.....	3	STORAGE.....	21
FULL SIZE HARDWARE CHART.....	4,5	TROUBLESHOOTING.....	21
CARTON CONTENTS.....	6	REPAIR PARTS ILLUSTRATION.....	22,24,26
ASSEMBLY.....	7	REPAIR PARTS LIST.....	23,25,26
OPERATION.....	18	SLOPE GUIDE.....	27
MAINTENANCE.....	19	PARTS ORDERING/SERVICE.....	BACK COVER

## IMPORTANT:

Rear wheel weights and tire chains are required to provide extra traction and stability when using this snow thrower attachment. These items are available where you purchased your tractor.

### WHEEL WEIGHTS

### TIRE CHAINS

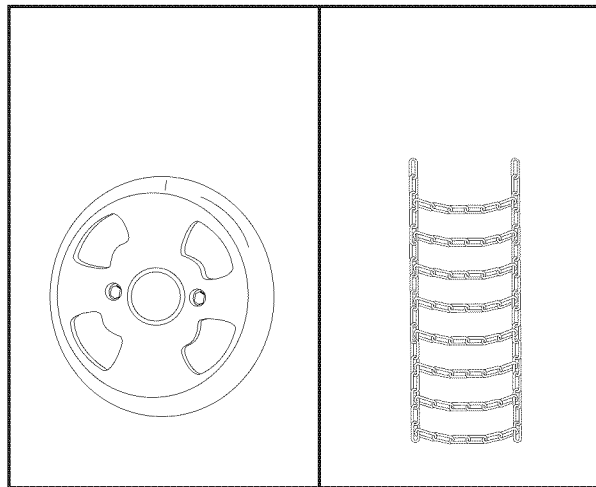



## SAFETY

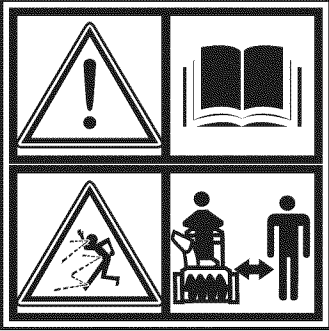

184045

Read and understand the operating instructions before using.

Keep the area of operation clear of all persons, especially small children and pets. Thoroughly inspect the area to be cleared and remove all door mats, sleds, boards, wires and other foreign objects. Use extreme caution when operating on or crossing gravel surfaces. Never direct discharge at bystanders or allow anyone in front of the snow thrower.



199682

Do not place hands near rotating parts. Keep clear of the discharge opening at all times.

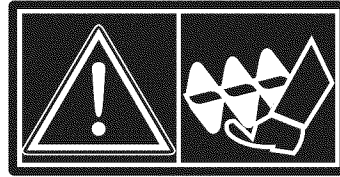

199683

Do not place feet near rotating parts.

- Never allow children to operate the equipment.
- Never allow adults to operate the equipment without proper instruction.
- Disengage all clutches and shift into neutral before starting engine.
- Do not operate equipment without wearing adequate winter outer garments.
- Wear substantial footwear which will protect feet and improve footing on slippery surfaces.
- Check fuel before starting the engine. Do not remove the fuel cap or fill the fuel tank while the engine is running or hot. Do not fill the fuel tank indoors. Gasoline is an extremely flammable fuel.
- Make sure the snow thrower height is adjusted to clear the type surface it will be used on.
- Do not use the snow thrower without wheel weights attached to the tractor.
- Never make any adjustments while the engine is running.
- Always wear safety glasses or eye shield during operation or while performing adjustment or repair.
- Do not place hands or feet near rotating parts. Keep clear of the discharge opening at all times.
- Do not carry passengers.
- After striking a foreign object, stop the engine, remove the wire from the spark plug and then thoroughly inspect the snow thrower for damage. Repair any damage before restarting and operating the snow thrower.
- If the snow thrower starts to vibrate abnormally, stop the engine immediately and check for the cause. Vibration is generally a warning of trouble.
- Stop the engine whenever you leave the operating position, before unclogging the snow thrower or making any adjustments or inspections.
- Take all possible precautions when leaving the unit unattended. Disengage the attachment clutch lever or switch, lower the snow thrower, shift into neutral, set the parking brake, stop the engine and remove the key.
- When cleaning, repairing or inspecting, make certain all moving parts have stopped. Disconnect the spark plug wire and keep it away from the plug to prevent accidental starting.
- Do not run engine indoors except when transporting the snow thrower in or out of the building. Open the outside doors. Exhaust fumes are dangerous.
- Do not clear snow across the face of slopes. Exercise extreme caution when changing direction on slopes. Do not attempt to clear steep slopes. Refer to the slope guide on page 35 of this manual.
- Never operate the snow thrower without guards, plates or other safety protection devices in place.
- Never operate the snow thrower near glass enclosures, automobiles, window wells, drop offs etc. without proper adjustment of the snow thrower discharge angle.
- Never run the snow thrower into snow at high speeds.
- Do not overload the snow thrower capacity by attempting to clear snow at too fast a rate.
- Never operate the snow thrower at high transport speed on slippery surfaces. Look behind and use care when backing up.
- Watch for traffic and stay alert when crossing or operating near roadways.
- Disengage power to the snow thrower when transporting or when not in use.
- Use only attachments and accessories approved by the manufacturer of the snow thrower (such as wheel weights, counter weights, cabs etc.)
- Never operate the snow thrower without good visibility.

# HARDWARE PACKAGE CONTENTS

**ATTENTION:** The hardware bags may contain some bolts and nuts which do not appear on this page or the following page. Those bolts and nuts will not be needed for the assembly of your snow thrower.

## SHOWN ACTUAL SIZE

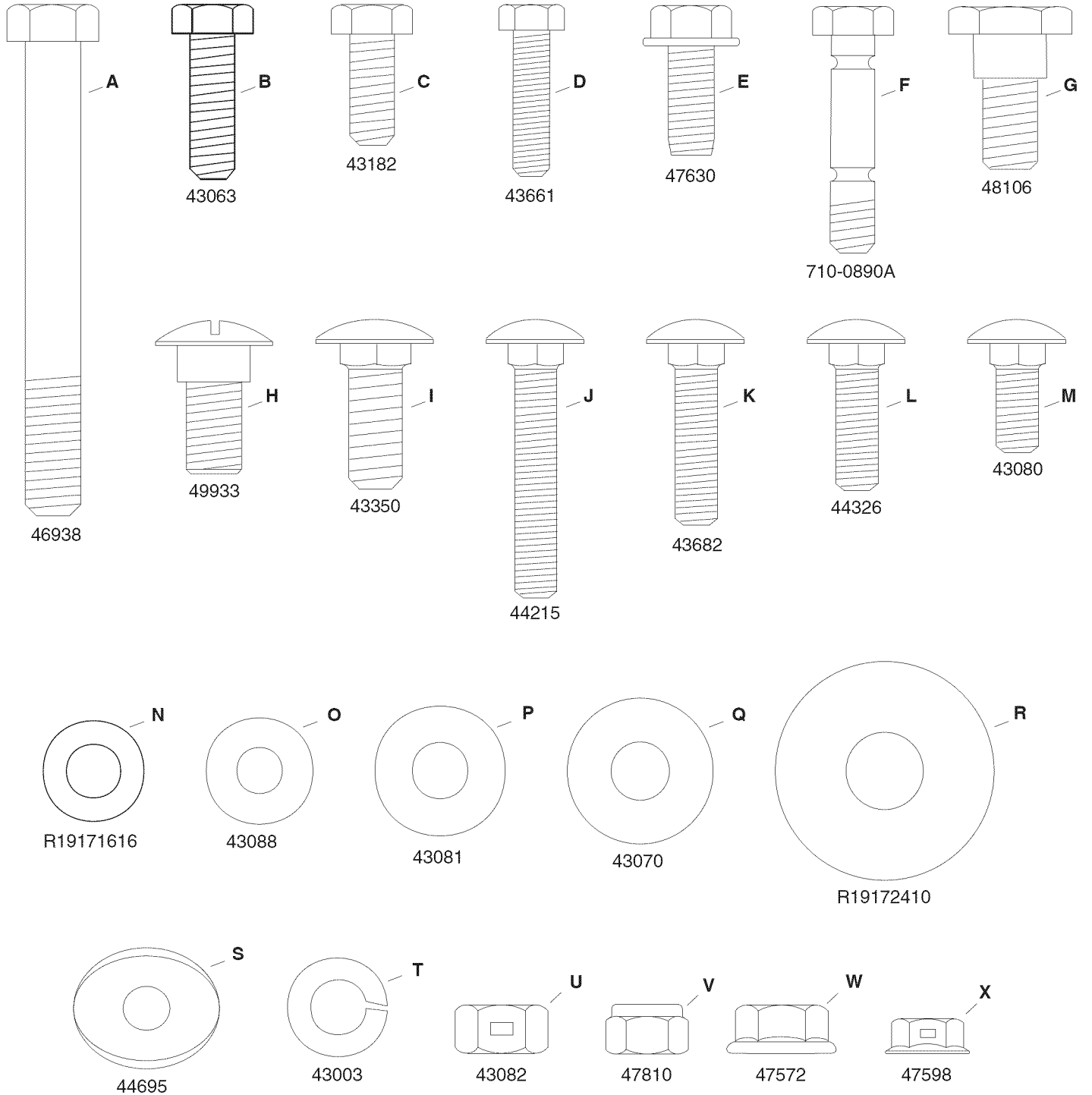

**NOT SHOWN ACTUAL SIZE**

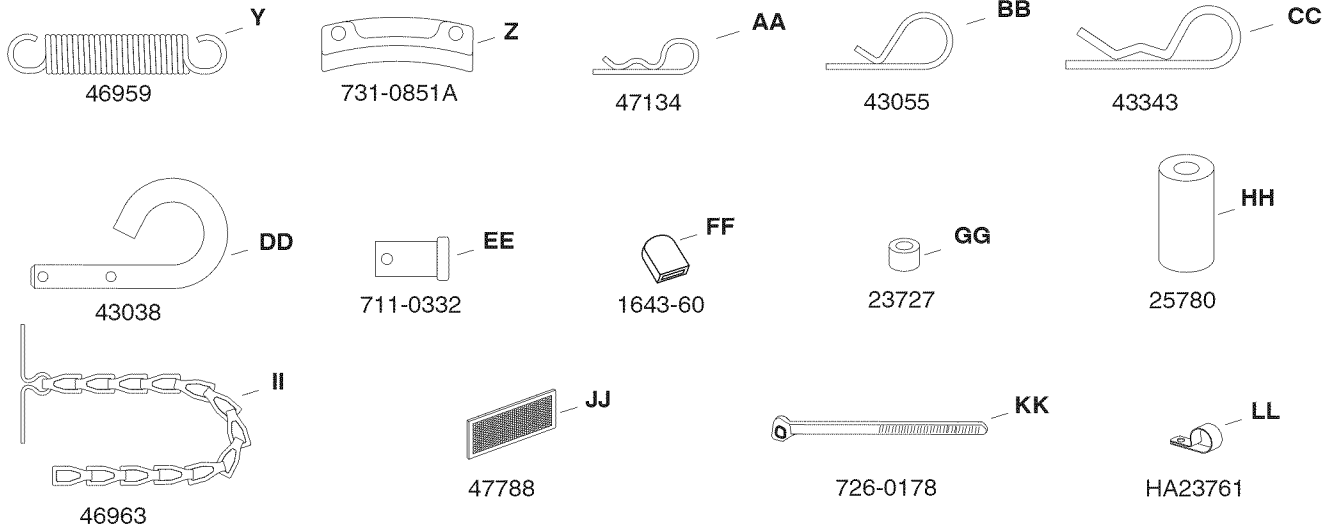

**IMPORTANT:** Not all items supplied in the hardware bags will be needed for your particular tractor. Unneeded items may be discarded after you have completed assembly and checked operation of unit. **DO NOT DISCARD** the two spare shear bolts (F) and 5/16" nylock nuts (V). Refer to the Service and Adjustments section on page 20.

REF.	QTY.	DESCRIPTION	REF.	QTY.	DESCRIPTION
A	1	Hex Bolt, 3/8" x 3-1/4"	T	1	Lock Washer, 3/8"
B	4	Hex Bolt, 5/16" x 1"	U	2	Hex Lock Nut, 3/8"
C	4	Hex Bolt, 5/16" x 3/4"	V	19	Nylock Nut, 5/16" (2 spare parts)
D	6	Hex Bolt, 1/4" x 1"	W	10	Flanged Nut, 3/8"
E	2	Hex Bolt, 5/16" x 3/4" (Thread Forming)	X	6	Flanged Nut, 1/4"
F	2	Shear Bolt (spare parts)	Y	1	Spring
G	2	Shoulder Bolt, Hex Head	Z	3	Chute Keeper
H	2	Shoulder Bolt, Round Head	AA	2	Hairpin Cotter, 5/64"
I	6	Carriage Bolt, 3/8" x 1"	BB	1	Hairpin Cotter, 3/32"
J	2	Carriage Bolt, 5/16" x 1-3/4"	CC	6	Hairpin Cotter
K	2	Carriage Bolt, 5/16" x 1-1/4"	DD	2	Lock Pin
L	4	Carriage Bolt, 5/16" x 1"	EE	2	Clevis Pin, 1/2" x 7/8"
M	1	Carriage Bolt, 5/16" x 3/4"	FF	1	Plastic Cap
N	1	Washer, 1/2" x 1"	GG	1	Spacer, 1/4"
O	7	Washer, 1/4"	HH	1	Spacer, 3/8"
P	19	Washer, 5/16" (Extra washers included)	II	2	Chain, Tensioning
Q	3	Washer, 3/8" Standard	JJ	2	Tail Reflector
R	4	Washer, 1/2" x 1-1/2"	KK	8	Nylon Tie
S	2	Bowed Washer	LL	1	Cable Clip

# CARTON CONTENTS

- |  |                                      |
|--|--------------------------------------|
| 1. Housing Assembly                              | 11. Clutch Idler Assembly            |
| 2. Chute Crank Rod Assembly                      | 12. Cable Bracket                    |
| 3. Support Tube, Crank Rod                       | 13. L.H. Hanger Bracket              |
| 4. Winch Assembly                                | 14. R.H. Hanger Bracket              |
| 5. Anti-rotation Bracket.                        | 15. Pulley                           |
| 6. Front Pulley Frame Bracket (2)                | 16. Chute and Control Cable Assembly |
| 7. Rear Pulley Frame Bracket (2)                 | 17. Right Hand Side Plate            |
| 8. V-Belt, Drive 56" (#48138)                    | 18. Left Hand Side Plate             |
| 9. V-Belt, Drive 55" (#46989)                    | 19. Switch Mounting Assembly         |
| 10. V-Belt, Auger (Attached to Housing Assembly) | 20. Wire Harness                     |

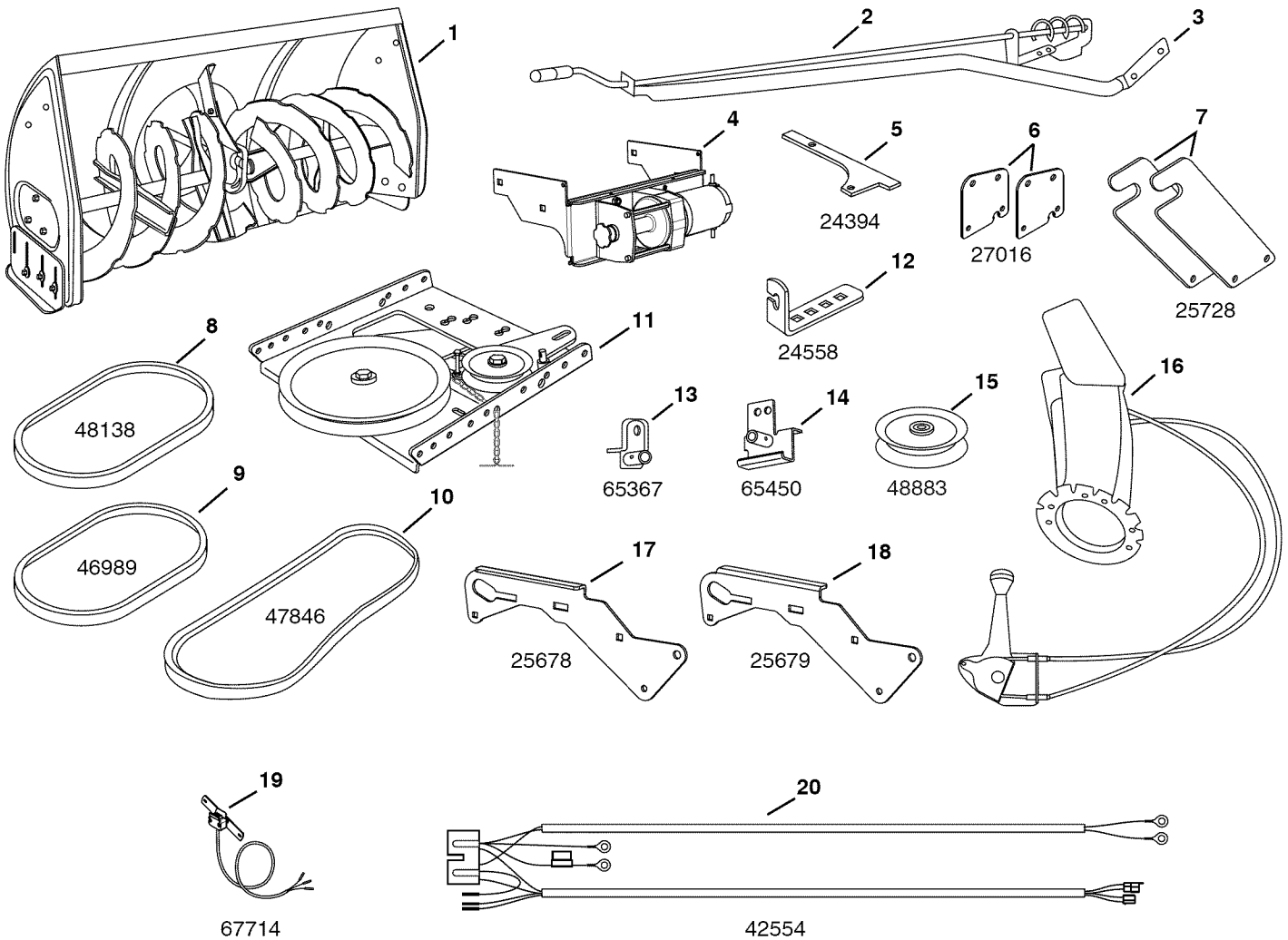

# ASSEMBLY

## TOOLS REQUIRED FOR ASSEMBLY

- (2) 7/16" Wrenches
- (2) 1/2" Wrenches
- (2) 9/16" Wrenches
- (2) 3/4" Wrenches
- (1) Screw Driver
- (1) Knife

## REMOVAL OF PARTS FROM CARTON

- Remove all loose parts, parts bags and hardware bags from the carton. Lay out and identify parts and hardware using the illustrations on pages 4, 5 and 6.

**IMPORTANT:** Not all items supplied in the hardware bag will be needed for your particular tractor. Unneeded items may be discarded after you have completed assembly and checked operation of unit. **DO NOT DISCARD** the two spare shear bolts and 5/16" nylock nuts. Refer to the Service and Adjustments section on page 20.



**CAUTION:** Before starting to assemble the snow thrower, remove the spark plug wire(s), set the parking brake and remove the key from the tractor ignition.



**CAUTION:** Do not begin assembling until the tractor engine, muffler and exhaust deflector have been allowed to cool off.

## TRACTOR PREPARATION

Before performing these instructions, refer to the Service and Adjustments section of your tractor owner's manual for specific safety instructions.

- Allow engine, muffler and exhaust deflector to cool before beginning.
- Remove any front or rear attachment which is mounted to your tractor.
- Remove the mower deck. Refer to your tractor owner's manual for removal instructions. Mark all loose parts and save for reassembly.
- Remove the tractor hood. Refer to your tractor owner's manual for removal instructions.

**IMPORTANT:** Right hand (R.H.) and left hand (L.H.) side of the tractor are determined from the operators position while seated on the tractor.

## ATTACHING PARTS TO TRACTOR FRAME

### STEP 1: (SEE FIGURE 1)

- Align the Winch and Bracket Assembly with the front of the tractor frame and install two 3/8" x 1" carriage bolts through each side of the tractor frame and the bracket. **Do not install any nuts yet.**

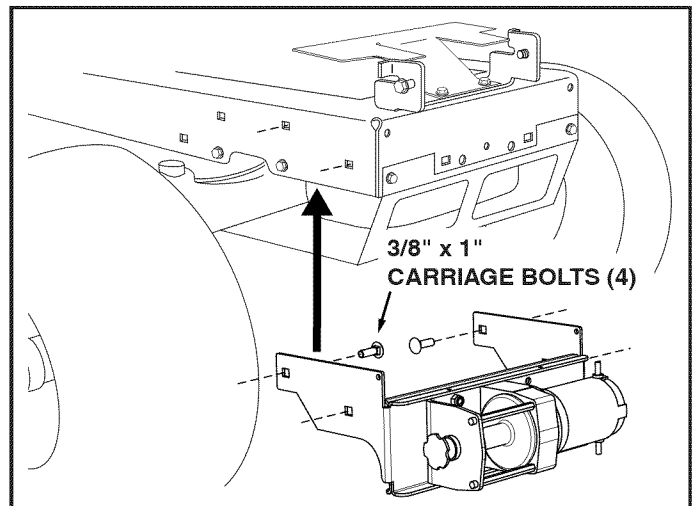

FIGURE 1

RIGHT SIDE VIEW

### STEP 2: (SEE FIGURE 2)

- On each side of the tractor frame insert a 3/8" x 1" carriage bolt and a 5/16" x 1" carriage bolt through the holes shown.
- Install a 1/2" x 1-1/2" washer onto each bolt unless there is an engine mounting plate present (depicted with dotted lines). If there is a plate, do not install a washer on the 3/8" bolt inserted through the plate.

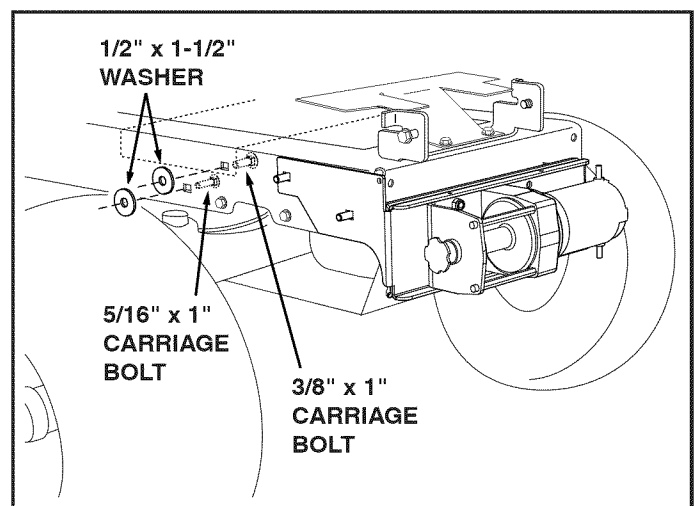
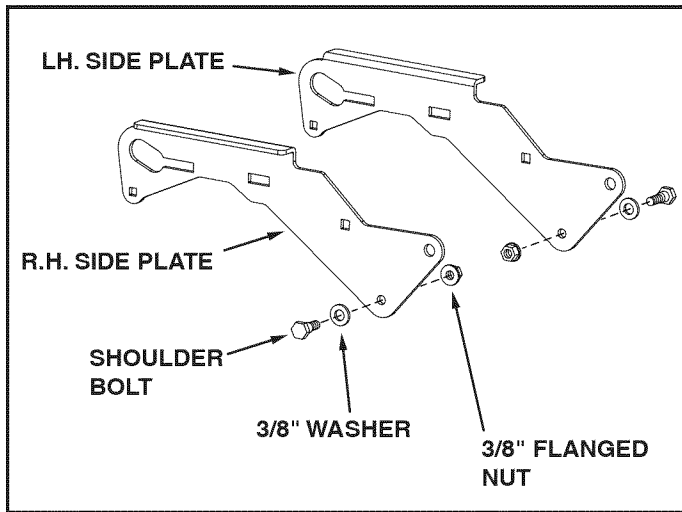

FIGURE 2

RIGHT SIDE VIEW

**STEP 3: (SEE FIGURE 3)**

- Install a hex head shoulder bolt, a 3/8" washer and a 3/8" flanged lock nut in the R.H. and L.H. Side Plates.

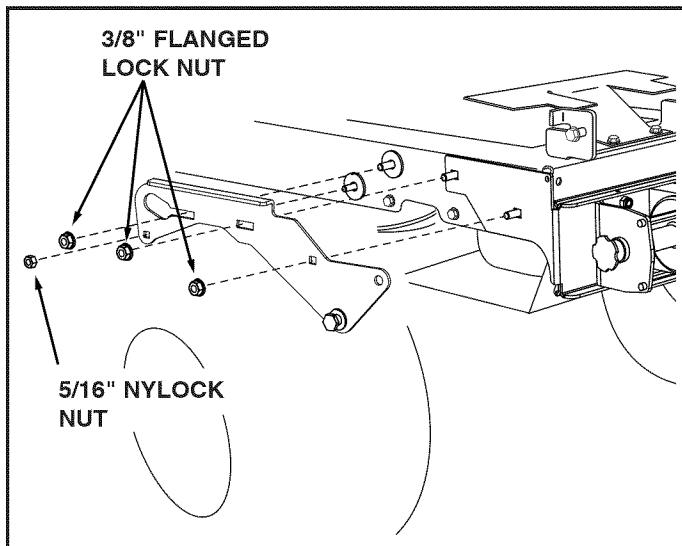

**FIGURE 3** **RIGHT SIDE VIEW**

**STEP 4: (SEE FIGURE 4)**

- Place the R.H. Side Plate onto the bolts you inserted into the tractor frame. Install three 3/8" flanged lock nuts and one 5/16" nylock nut onto the bolts. **Tighten.**
- Repeat for the L.H. Side Plate.

**HINT:** To help prevent the carriage bolts from spinning, push against the head of the bolt while tightening to keep the square neck of the bolt seated in the square hole.



**FIGURE 4** **RIGHT SIDE VIEW**

**STEP 5: (SEE FIGURE 5)**

- Remove the two screws in the right side of the plastic dash housing.
- Install the cable clip onto the rocker switch wiring. Attach the switch mounting assembly and clip to the side of the plastic dash housing, using the two screws.

**CONNECTING THE RELAY BOX**

**STEP 6: (SEE FIGURE 5)**

**FRONT MOUNTED BATTERY ONLY**

- Position the wire harness relay box against the front of the battery tray on the right hand side. Attach it to the slot in the top of the battery tray using a plastic tie.
- Connect the long black wire on the wire harness to the negative post on the battery.
- Connect the red wire (with circuit breaker) to the positive post on the battery.

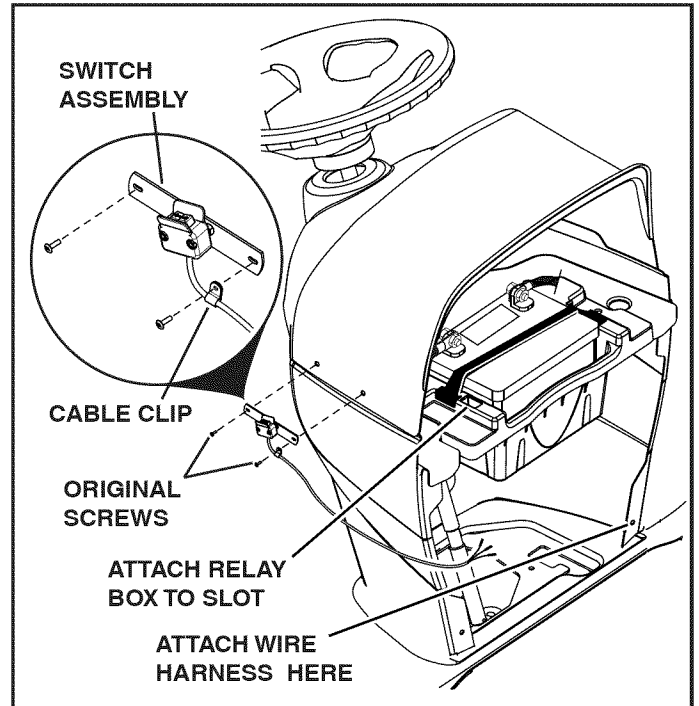

**FIGURE 5** **RIGHT SIDE VIEW**



## STEP 7:

### REAR MOUNTED BATTERY ONLY

- Mount the wire harness relay box in front of the solenoid on the right hand side of the gas tank, attaching it with a plastic tie.
- Attach the long black wire of the wire harness under the head of the screw that fastens down the right hand side of the gas tank.
- Attach the red wire (with circuit breaker) to the rear solenoid terminal where the battery cable is attached.
- Connect the short red, black and green wires to the three wires of the switch mounting assembly, joining together like colored wires.

## INSTALLING THE WIRE HARNESS

### STEP 8:

- Connect the three wires of the switch mounting assembly to the wires with mating connectors from the wire harness, joining together like colored wires.
- Route the end of the wire harness with the green and black wires around behind the tractor's wiring and then forward along the right side of the tractor.
- Route the other end of the wire harness around to the left side of the tractor.
- Loosely attach the wire harness to rear of each side plate installed in step 4, and to the front corners of the tractor frame using two plastic ties per side.
- Connect the wire harness to the winch motor using the pre-assembled nut and washers. Place the brown wire on the top terminal and the black wire on the bottom terminal. See figure 6.
- Tighten the plastic ties.

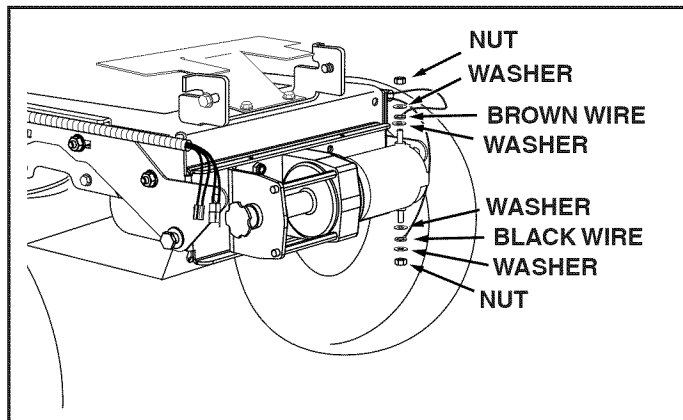

FIGURE 6

RIGHT SIDE VIEW

## INSTALL HANGER BRACKETS AND SHOULDER BOLTS TO OUTSIDE OF FRAME

### STEP 9: (SEE FIGURE 7)

- Remove the bolt, if present, in the hole directly behind the brake rod on the left side of the tractor frame.
- Attach the L.H. Hanger Bracket (tube facing out) to the hole using a 5/16" x 3/4" self threading bolt.
- Install a round head shoulder bolt into the hole that is 9-1/2" to the rear of the bolt you just installed. Secure it with a 3/8" flange nut on the inside of the frame.

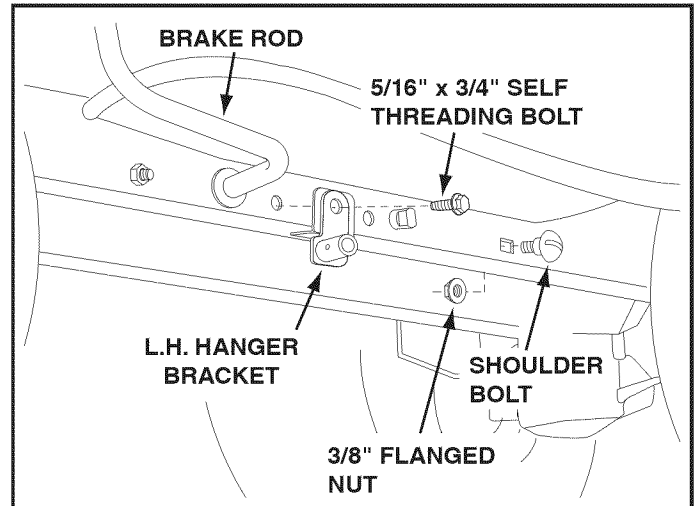

FIGURE 7

LEFT SIDE VIEW

### STEP 10: (SEE FIGURE 8)

- Remove the bracket, if present, from the hole directly behind the end of the brake rod on the right side of the tractor frame. Store the bracket and bolt.
- Attach the R.H. Hanger Bracket to the hole using a 5/16" x 3/4" self threading bolt.
- Install a round head shoulder bolt into the hole that is 9-1/2" to the rear of the bolt you just installed. Secure it with a 3/8" flange nut on the inside of the frame.

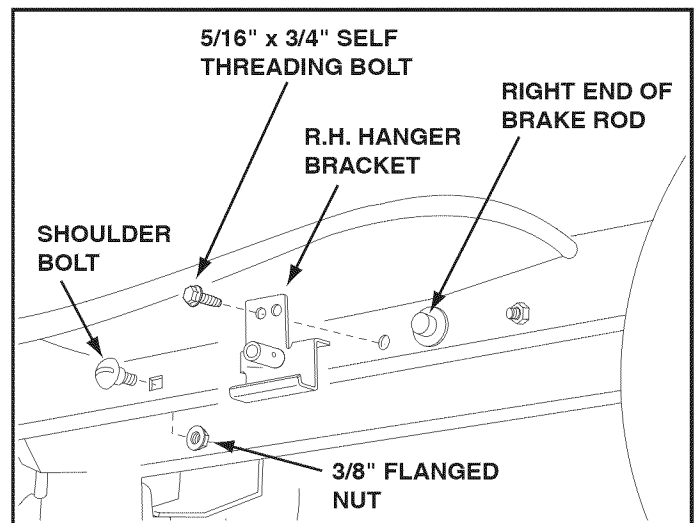

FIGURE 8

RIGHT SIDE VIEW

**THIS SECTION IS FOR TRACTORS WITH A  
MANUAL ATTACHMENT CLUTCH**

If your tractor has an electric attachment clutch go to step 18 on page 12.

**STEP 11: (SEE FIGURE 9)**

- Attach the cable bracket to the double hole in the clutch/idler assembly as shown, using a 5/16" x 3/4" carriage bolt and a 5/16" nylock nut. Place the bolt in the front hole of the bracket and in the end of the hole closest to the pulley. **Do not tighten yet.**

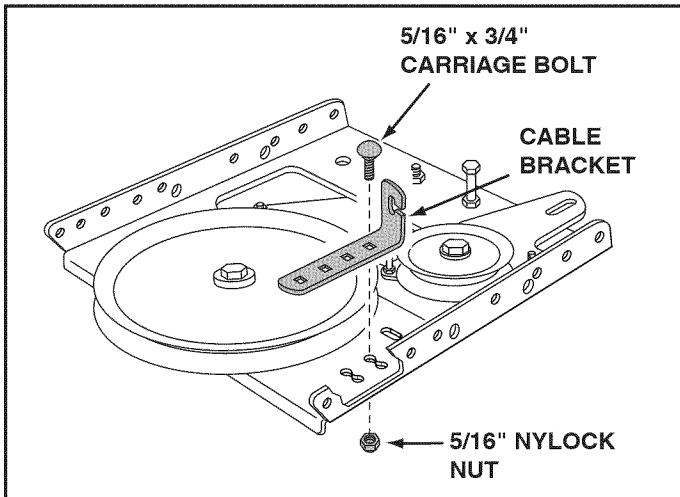

**FIGURE 9**

**STEP 12: (SEE FIGURE 10)**

- Attach the pulley (long end of hub facing down) and the 3/8" spacer to the clutch/idler assembly. Use a 3/8" x 3-1/4" hex bolt, a 3/8" washer, a 3/8" lock washer and a 3/8" hex lock nut.
- Insert a tensioning chain through the hole shown and attach the end link to the spring on the lower idler arm.

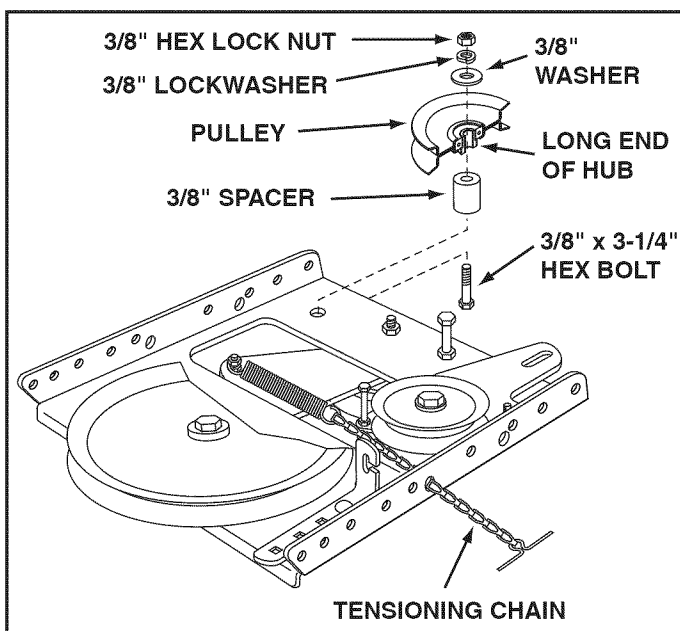

**FIGURE 10**

**STEP 13: (SEE FIGURE 11)**

- Attach each rear pulley frame bracket to the inside of the clutch/idler assembly using two 5/16" x 3/4" hex bolts, 5/16" washers and 5/16" nylock nuts.
- Attach each front pulley frame bracket to the inside of the clutch/idler assembly using two 5/16" x 1" hex bolts, four 5/16" washers and two 5/16" nylock nuts.

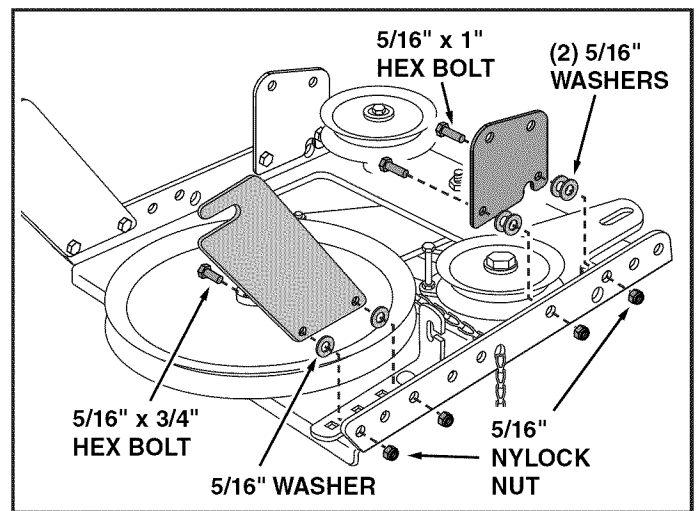

**FIGURE 11**

**STEP 14: (SEE FIGURE 12)**

- Two different length drive belts are included with your snow thrower. Use the longer, 56" drive belt (#48138) on tractors with manual attachment clutches.
- Slightly loosen the hex bolt next to the flat idler pulley. Install the drive belt down between the hex bolt and the flat idler pulley with the flat side of the belt against the pulley. Retighten the hex bolt.
- Loop the belt around the large V-pulley, placing it between the V-pulley and the hex bolt next to the pulley. Place the belt to the inside of the other flat idler pulley.

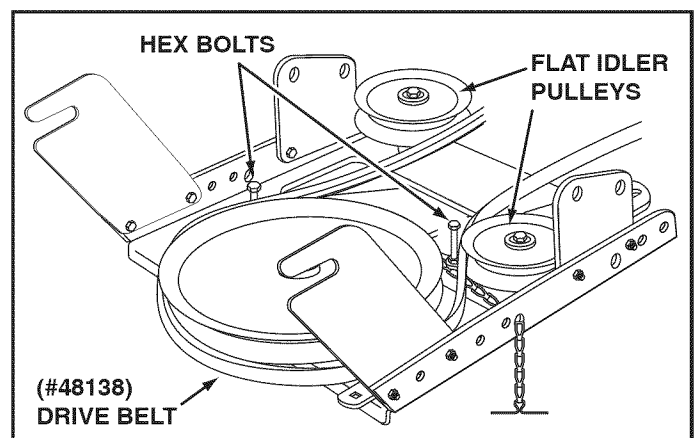

**FIGURE 12**



Did you select the correct drive belt for your tractor? Using the wrong length belt may cause premature bearing or belt failure.

**STEP 15: (SEE FIGURE 13)**

- Find the cable clip that is attached to the left side of the tractor frame underneath the footrest. Open the clip and remove the mower clutch cable. **Do not remove** the clip from the tractor frame. The cable reattaches to the clip when using the mower deck.
- Move the attachment clutch lever on the dash panel to the disengaged position.
- Place the clutch/idler assembly on the floor on the left side of the tractor.
- Attach the tractor's mower clutch cable to the cable bracket on the clutch/idler assembly. Secure the cable housing guide (groove down) to the cable bracket using the original collar and retainer spring.
- Place a 1/4" spacer on the welded pin on the idler arm. Hook the end of the clutch cable spring over the pin and secure it with a 1/4" washer and a 5/64" hair cotter pin.
- Align cable bracket with welded pin and tighten the nut assembled in step 11.

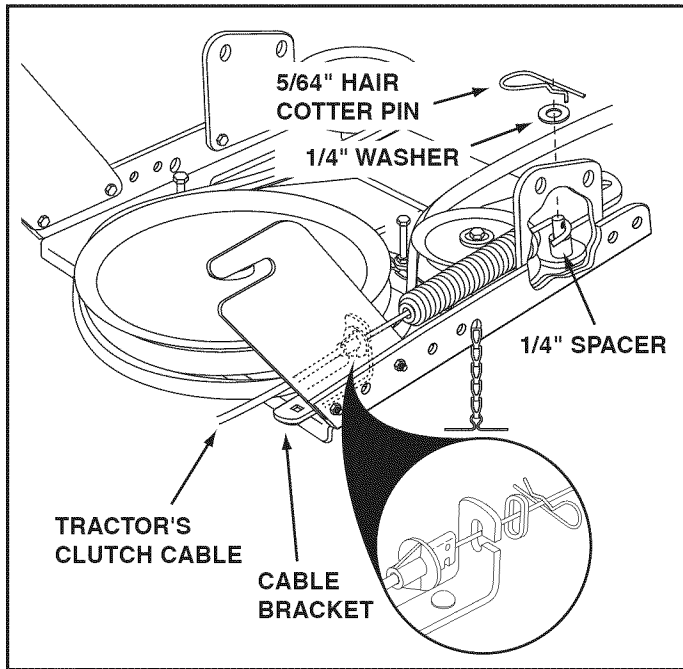

FIGURE 13

**ATTACH CLUTCH IDLER ASSEMBLY TO TRACTOR**

**STEP 16: (SEE FIGURE 14)**

- Attach the clutch/idler assembly to the tractor frame. Hook the notched rear pulley frame brackets onto the two shoulder bolts assembled to the outside of the tractor frame. Lift the front of the assembly and attach it to the R.H. and L.H. hanger brackets using two pivot lock pins and 1/8" hairpin cotters.
- Loosely attach the mower clutch cable to the left side of the tractor frame with a nylon tie. **Do not** pull the nylon tie completely tight. The cable may need to be removed from the nylon tie when using the mower deck.

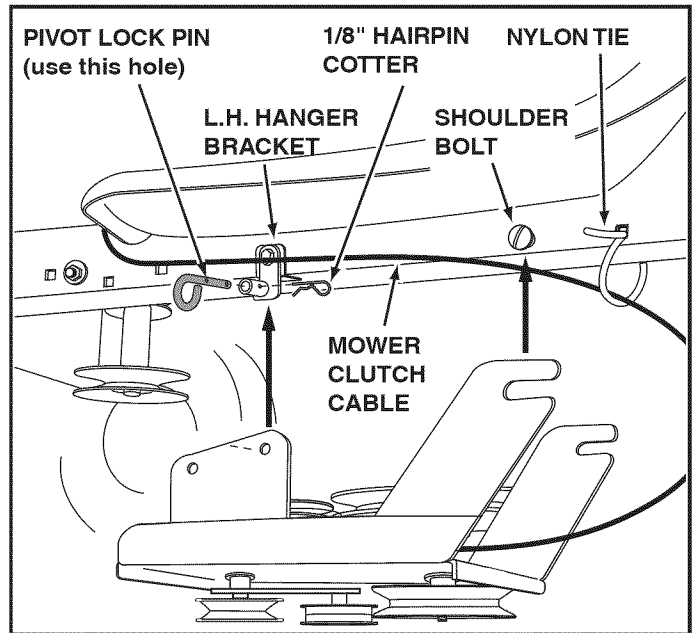

FIGURE 14 VIEWED FROM LEFT SIDE

**STEP 17: (SEE FIGURE 15)**

- Assemble the drive belt onto the engine pulley, routing it through the engine pulley belt keepers.

**HINT:** You may need to remove the belt from the large pulley on the clutch/idler assembly in order to assemble it onto the engine pulley. When re-assembling the belt onto the large pulley, be sure the belt is between the large pulley and the hex bolt next to it.

- Go to step 24 on page 14.

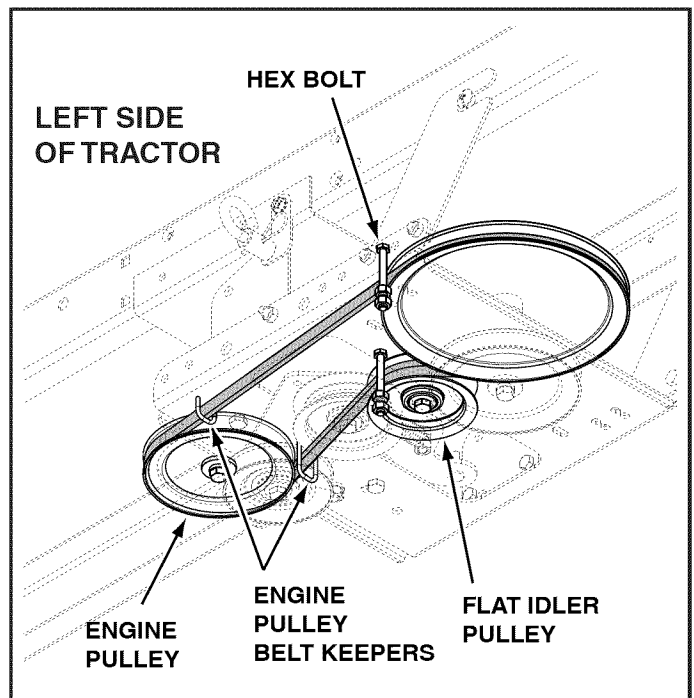
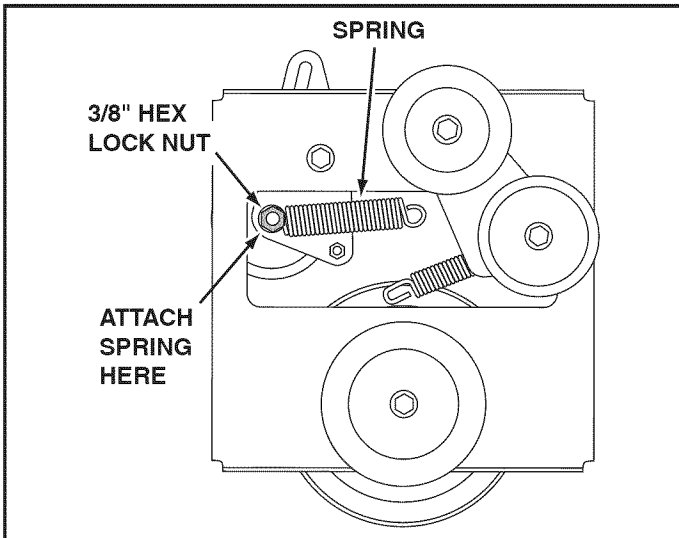

FIGURE 15 VIEWED FROM UNDERNEATH

**THIS SECTION IS FOR TRACTORS WITH AN ELECTRIC ATTACHMENT CLUTCH**

**STEP 18: (SEE FIGURE 16)**

- Turn the clutch idler assembly upside down.
- Hook the spring onto the end of the bolt that extends through the nut on the bottom of the upper idler arm. Install a 3/8" hex lock nut onto the bolt, leaving enough space for the spring to pivot.



**FIGURE 16** **BOTTOM VIEW**

**STEP 19: (SEE FIGURE 17)**

- Insert tensioning chains through the holes shown and attach to the springs on the upper and lower idler arms.
- Install a 3/32" hairpin cotter in the chain attached to the upper idler arm, placing it in the fifth link from the spring.

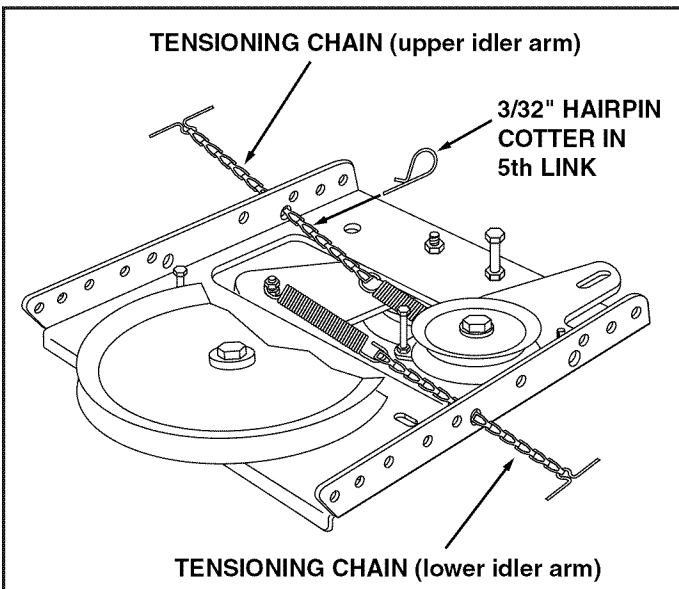

**FIGURE 17**

**STEP 20: (SEE FIGURE 18)**

- Attach each rear pulley frame bracket to the inside of the clutch/idler assembly using two 5/16" x 3/4" hex bolts, 5/16" washers and 5/16" nylock nuts.
- Attach each front pulley frame bracket to the inside of the clutch/idler assembly using two 5/16" x 1" hex bolts, four 5/16" washers and two 5/16" nylock nuts.

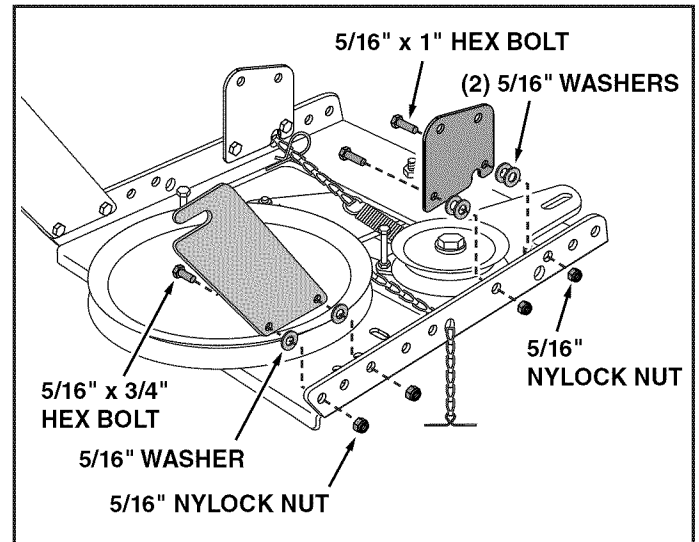

**FIGURE 18**

**STEP 21: (SEE FIGURE 19)**

- Two different length drive belts are included with your snow thrower. Use the shorter, 55" drive belt (#46989) on tractors with electric clutches.
- Turn the clutch/idler assembly right side up.
- Slightly loosen the hex bolt next to the flat idler pulley. Install the drive belt between the hex bolt and the flat idler pulley. Retighten the hex bolt.
- Loop the belt around the large V-pulley, placing it between the V-pulley and the hex bolt next to the pulley.

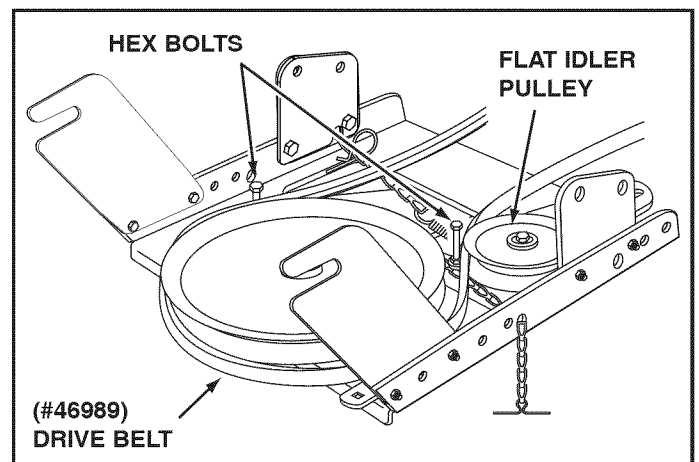
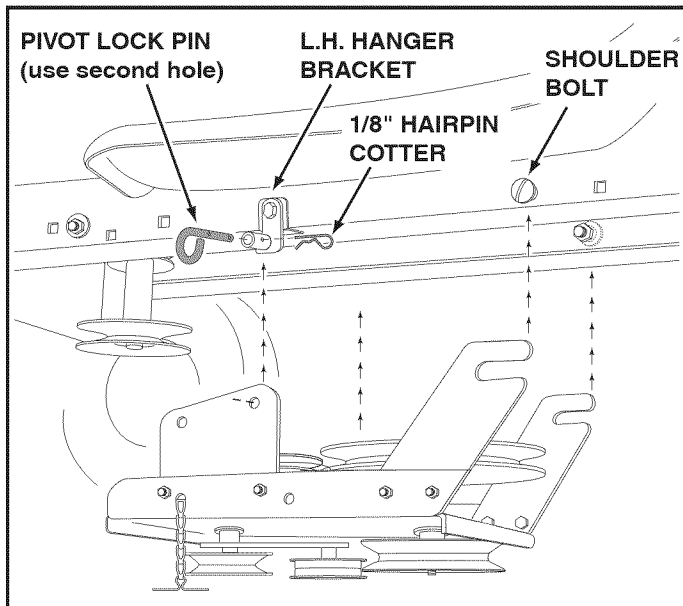

**FIGURE 19**

**STOP** Did you choose the correct drive belt for your tractor? Using the wrong length belt may cause premature bearing or belt failure.

**STEP 22: (SEE FIGURE 20)**

- Attach the clutch/idler assembly to the tractor frame. Hook the notched rear pulley frame brackets onto the two shoulder bolts assembled to the outside of the tractor frame. Lift the front of the assembly and attach it to the R.H. and L.H. hanger brackets using two pivot lock pins and 1/8" hairpin cotters.



**FIGURE 20**

**VIEWED FROM LEFT SIDE**

**STEP 23: (SEE FIGURE 21)**

- Assemble the drive belt onto the engine pulley. You may need to remove the belt from the large pulley on the clutch/idler assembly in order to assemble it onto the engine pulley. When re-assembling the belt onto the large pulley, be sure the belt is between the large pulley and the hex bolt next to it.
- Place tension on the belt by pulling the left side tensioning chain out as far as the 3/32" hairpin cotter that was installed in the chain in step 17 will allow. Secure the chain in this position by inserting a 1/8" hairpin cotter through the chain.

**NOTE:** To prevent the chain from dragging on the ground, loop the end of the chain through the pivot lock pin. Refer to figure 31 on page 16.

- Go to step 24 on page 14.

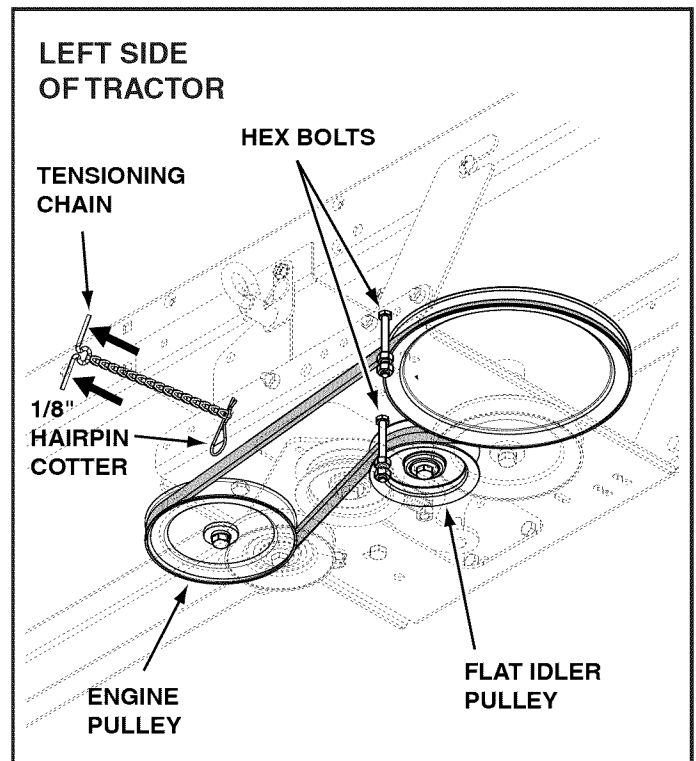

**FIGURE 21**

**VIEWED FROM UNDERNEATH**

**STEP 24: (SEE FIGURE 22)**

- Remove the nylon tie which fastens the chute crank rod to the crank rod support tube.
- Assemble the crank rod support tube to the bracket on the left side of the discharge housing using two 5/16" x 1-1/4" carriage bolts, and 5/16" Nylock nuts.

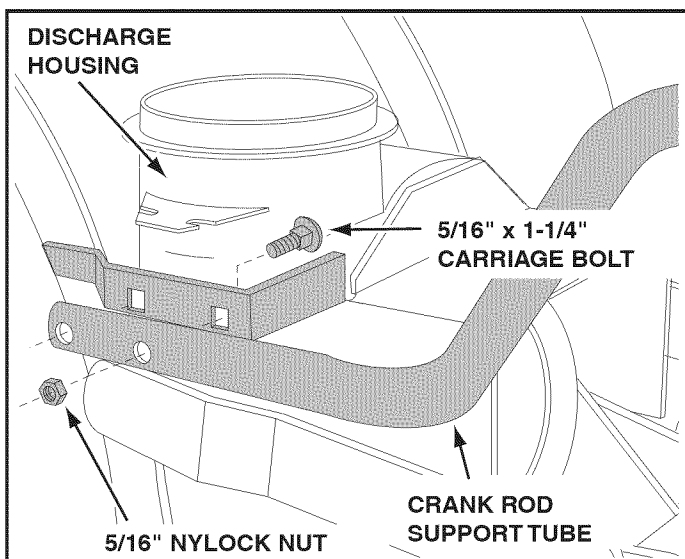

FIGURE 22

LEFT SIDE VIEW

**STEP 26: (SEE FIGURE 24)**

- Attach the chute crank rod assembly brackets to the plastic bracket on the left side of the discharge housing. Align the chute crank bracket beneath the rod support bracket and assemble both to the plastic bracket using two 5/16" x 1" carriage bolts, 5/16" washers and 5/16" Nylock nuts. **Do not tighten yet.**

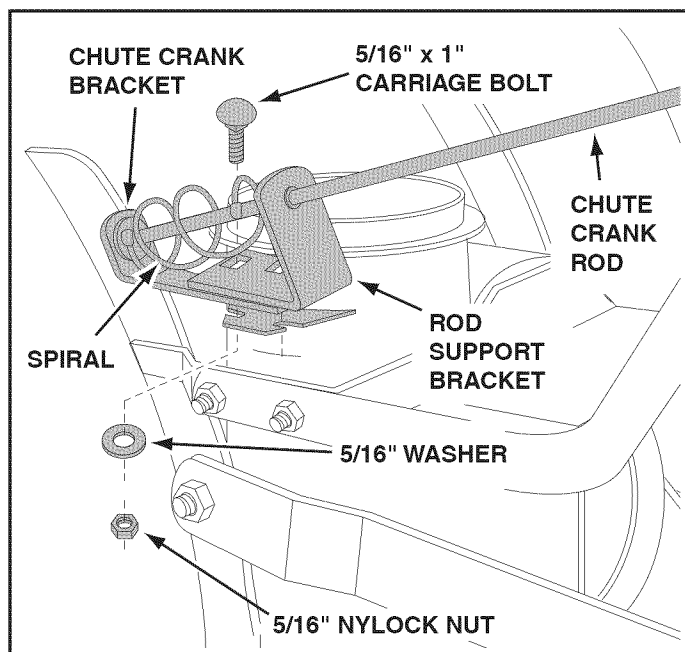

FIGURE 24

LEFT SIDE VIEW

**STEP 25: (SEE FIGURE 23)**

- Attach the chute tilt control assembly to the top side of the crank support tube using two 5/16" x 1-3/4" carriage bolts, bowed washers and 5/16" Nylock nuts.

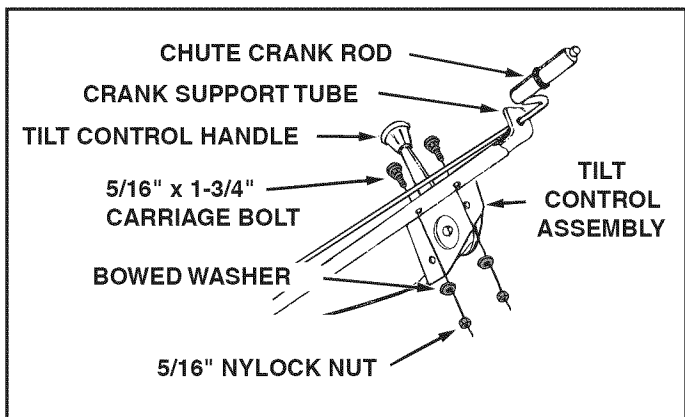

FIGURE 23

LEFT SIDE VIEW

### STEP 27: (SEE FIGURE 25)

- Coat the top of the ring around the discharge opening with general purpose grease.
- Place the discharge chute (facing forward) onto the ring. Place the anti-rotation bracket on top of the chute flange, aligning it with the holes on the right hand side of the flange. Attach the three chute keepers (right side up as shown) to the bottom of the flange using six 1/4" x 1" hex bolts, 1/4" flat washers and 1/4" flanged lock nuts. **Tighten carefully** so that the nuts are snug but do not dig into the plastic chute keepers.
- Place the plastic cap onto the short end of the anti-rotation bracket.
- Position the crank rod spiral (see figure 24 on page 14) so that it does not rub against the bottoms of the notches in the chute flange. **Tighten** the nuts.
- Check if the crank rod rotates the chute freely. If not, loosen by 1/4 turn each of the six hex bolts holding the chute keepers to the chute flange.
- Secure the control cables to the crank rod support tube using two nylon ties.

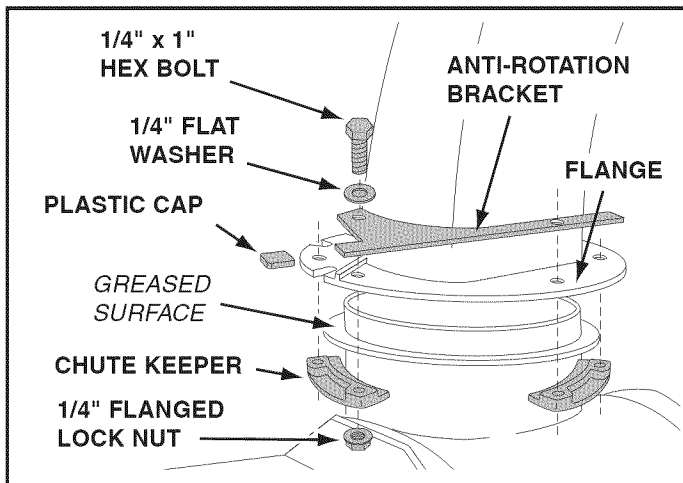

FIGURE 25

RIGHT SIDE VIEW

### ATTACHING SNOW THROWER TO TRACTOR

#### STEP 28: (SEE FIGURE 26)

- Place the snow thrower on a flat, level surface.
- Extend the auger belt out behind the snow thrower, leaving the belt assembled to the snow thrower pulleys.
- Roll the tractor up behind the snow thrower, centering it between the snow thrower's mounting plates.
- Lift up on the crank rod support tube to raise the rear of the snow thrower and align the notches in the mounting plates align with the shoulder bolts in the tractor's side plates. Roll the tractor forward, guiding the shoulder bolts into the notches.
- Install the two 1/2" x 7/8" clevis pins and 1/8" hairpin cotters to secure the snow thrower to the tractor.

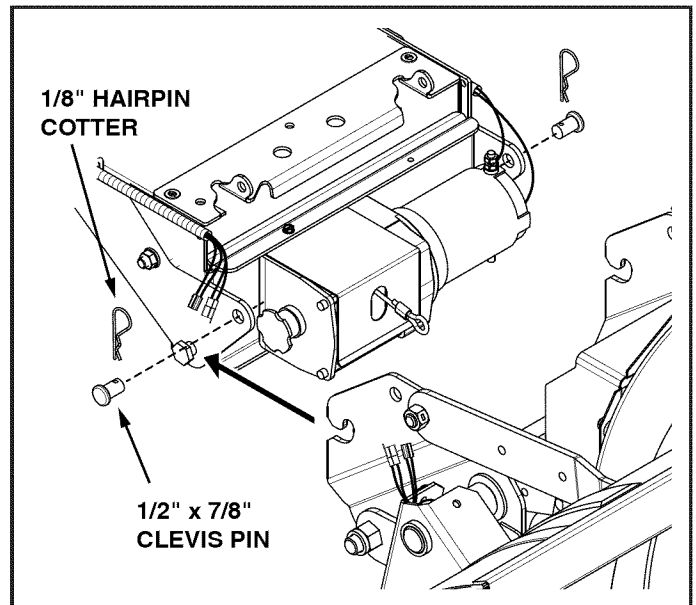

FIGURE 26

RIGHT SIDE VIEW

#### STEP 29: (SEE FIGURE 27)

- Connect the terminals of the wire harness attached to the tractor with the wire terminals of the limit switches on the snow thrower.

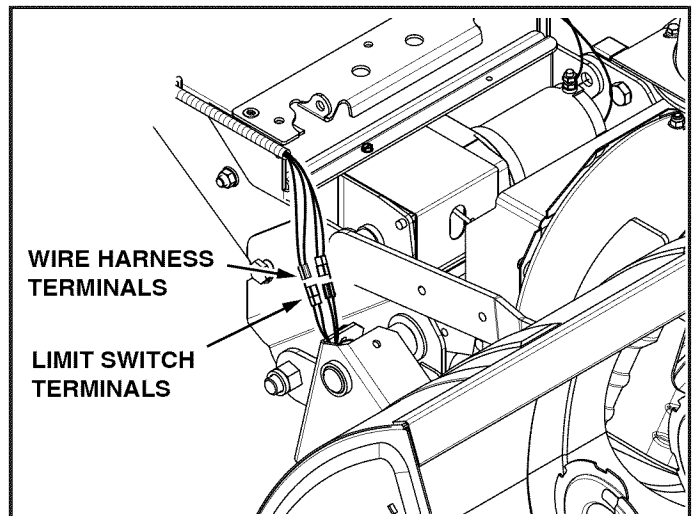

FIGURE 27

RIGHT SIDE VIEW

**STEP 30: (SEE FIGURE 28)**

- Place the end of the winch cable onto the lift link.  
Place a 1/2" washer onto the link and install a 5/64" hairpin cotter.

**HINT:** Push on the lift stop plate to rotate the lift link into better position to install the winch cable.

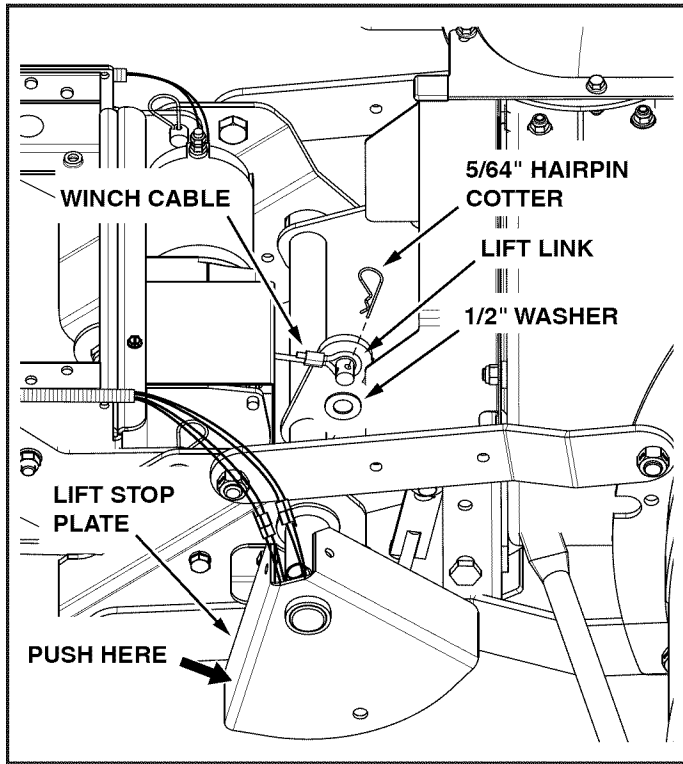

**FIGURE 28** VIEWED FROM UNDERNEATH

**STEP 31: (SEE FIGURE 29)**

- Check to make sure the auger belt is still properly seated around the snow thrower's auger pulley and idler pulleys.

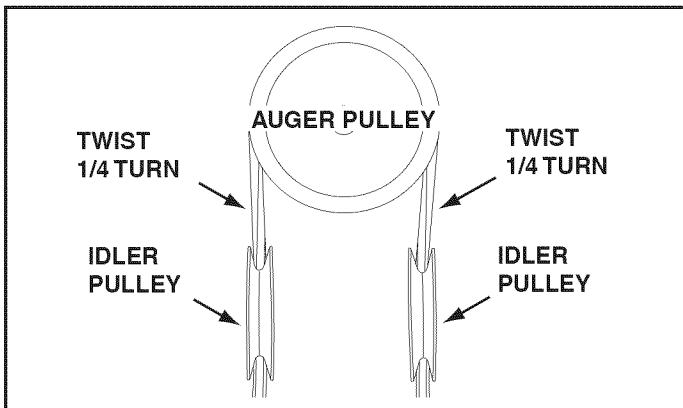

**FIGURE 29**

**INSTALLING THE AUGER BELT**

**STEP 32: (SEE FIGURE 30)**

- Start with the snow thrower lowered to the ground.
- Swing the idler arm over to the L.H. side of the tractor.
- Place the auger belt around the rear V-pulley and between the two idler arm pulleys. The "V" side of the belt must be seated in the grooves of the V-pulleys.

**HINT:** If the belt is too tight to assemble, try temporarily releasing the spring tension on the upper drive belt and then turning the rear pulley while rolling the auger belt onto it. If the belt is still too tight to assemble, try raising the snow thrower to see if the belt is looser in that position.

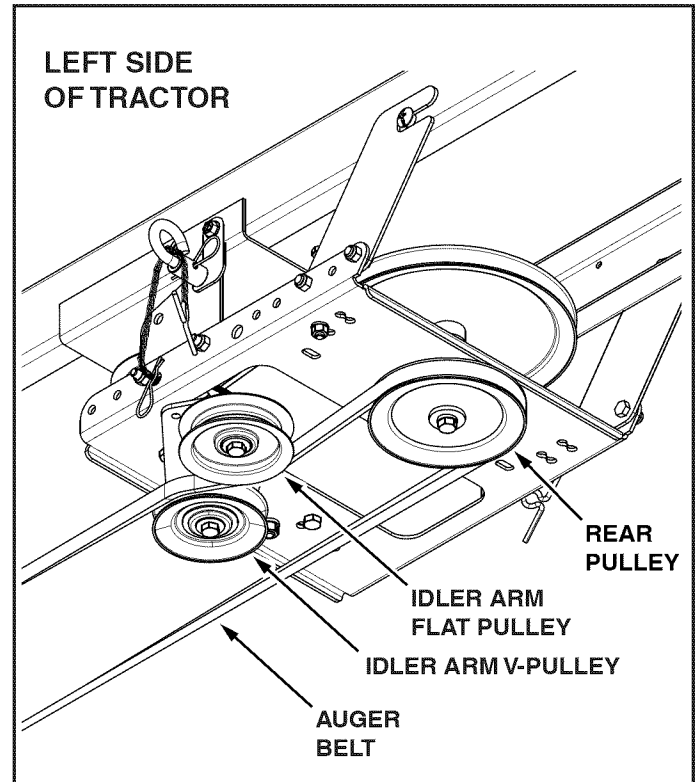

**FIGURE 30** VIEWED FROM UNDERNEATH

**BELT ROUTING DIAGRAM**

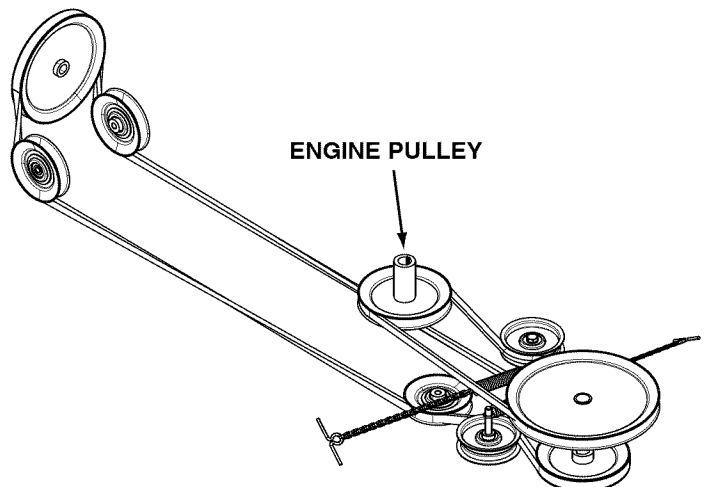



## SETTING THE AUGER BELT TENSION

### STEP 33: (SEE FIGURE 31)

- Pull the right side tensioning chain until the end of the spring is pulled into the hole in the side of the Clutch/Idler assembly. Install a 1/8" hairpin cotter through the end of the spring, securing it on the outside of the Clutch/Idler assembly.

**IMPORTANT:** For correct belt tension, the 1/8" hairpin cotter must attach to the end of the spring, not to the chain.

**NOTE;** To prevent the chain from dragging on the ground, loop the end of the chain through the pivot lock pin. Refer to figure 30 on page 16.

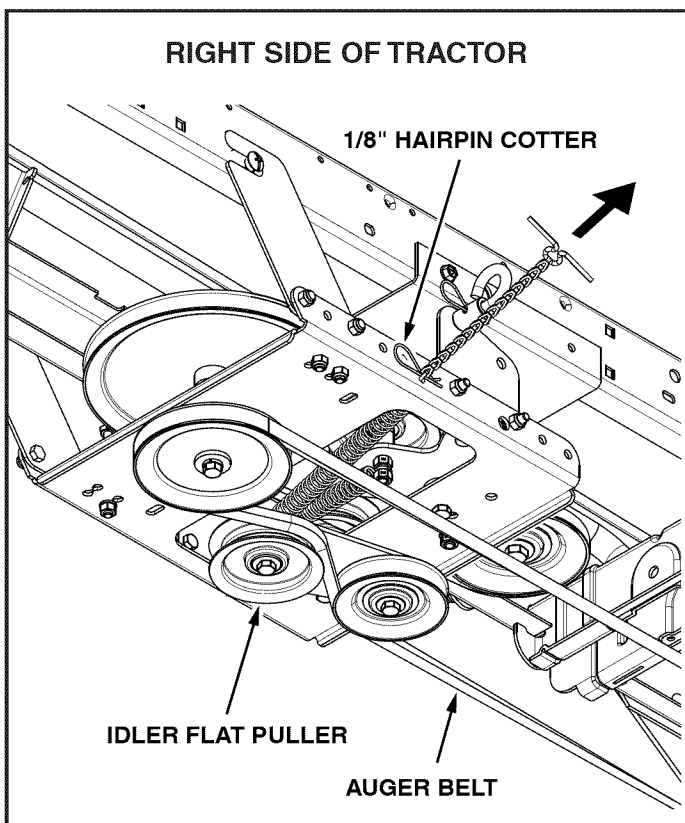

FIGURE 31 VIEWED FROM UNDERNEATH

## ATTACH REFLECTORS TO REAR FENDER

### STEP 34: (SEE FIGURE 32)

- If your tractor is not equipped with rear reflectors, assemble the supplied rear reflectors to the rear fender. Place the reflectors as close to the bottom of the fender and as far apart as the shape of the fender will allow.

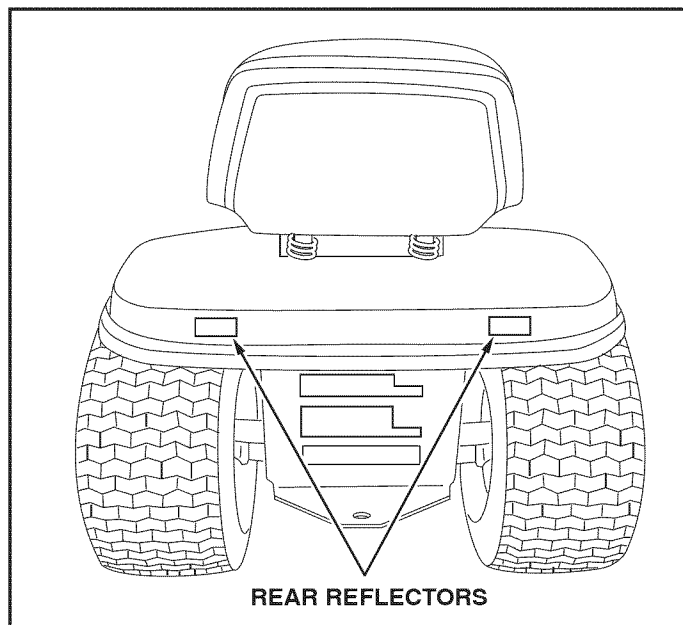

FIGURE 32

## CHECKLIST

**Before you operate your snow thrower, please review the following checklist to help ensure that you will obtain the best performance from your snow thrower.**

- Make sure all assembly instructions have been completed with all bolts and nuts properly tightened.
- Make sure the correct drive belt was installed.
- Make sure the drive belt and auger belt are routed properly around pulleys and inside all belt keepers.
- Check discharge chute for proper rotation.
- Check operation of tilt control for upper chute.
- Verify that the snow thrower raises and lowers properly.
- Check skid shoe adjustment. (Refer to the Service and Adjustments section.)

# OPERATION

## KNOW YOUR SNOW THROWER

Read this owner's manual and safety rules before operating your snow thrower.

Compare the illustration below with your snow thrower to familiarize yourself with the various controls and their locations.

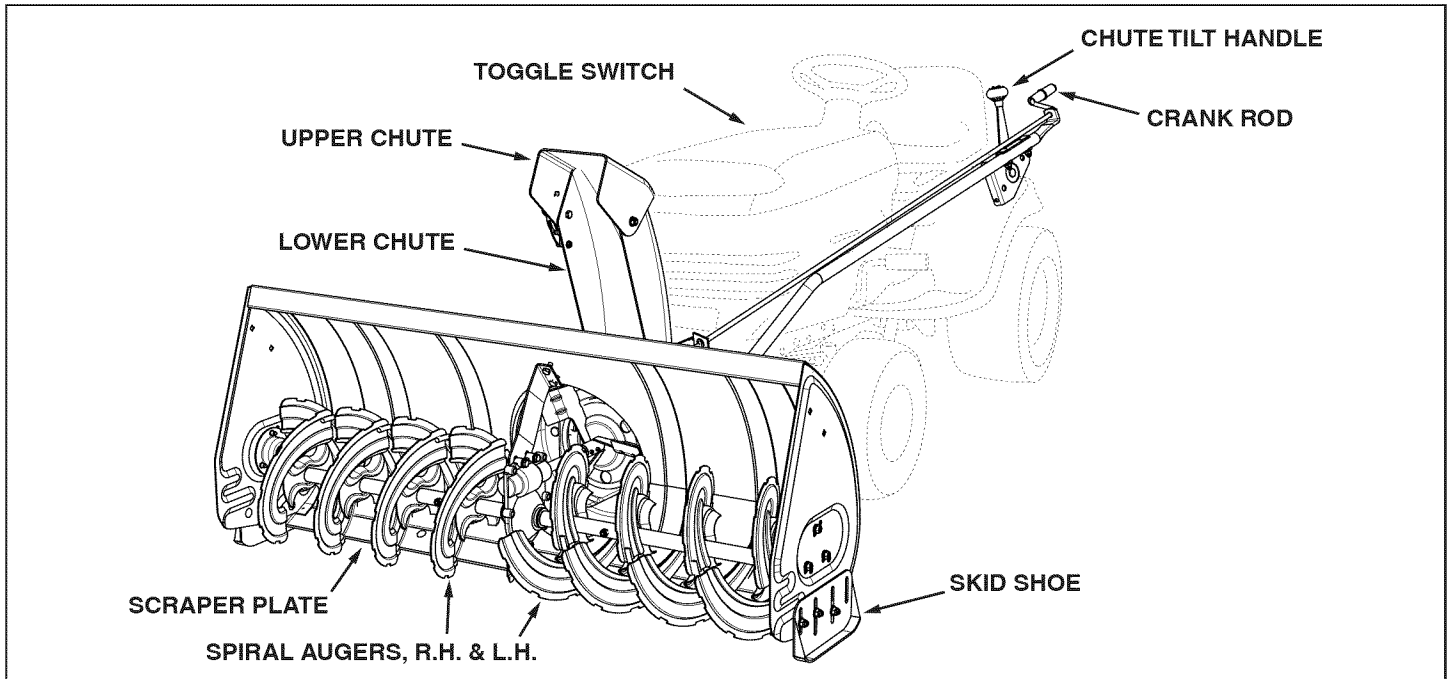

**CHUTE TILT HANDLE** Pivots the Upper Chute up or down to control the angle and distance of discharge.

**CRANK ROD** Rotates the Lower and Upper Chutes to control the direction of discharge.

**TOGGLE SWITCH** Used to raise or lower the snow thrower to transport or operating position.

**UPPER AND LOWER DISCHARGE CHUTE** Controls direction and height of snow discharge.

**SCRAPER PLATE** Replaceable plate that absorbs wear and impact from contact with ground.

**SKID SHOE** Controls amount of clearance between the scraper plate and the ground.

**SPIRAL AUGER, R.H. & L.H.** Feed snow to the impeller fan at the center of the housing.

## BEFORE STARTING

- Use the end of assembly checklist to verify that all instructions have been properly completed.
- Make sure the skid shoes are adjusted to maintain adequate ground clearance between the snow thrower and the type of surface to be cleared. (Refer to the Service and Adjustments section.)
- Make sure the tractor engine has the correct oil for winter operation (SAE 5W-30). Refer to tractor owner's manual.

## HOW TO START YOUR SNOW THROWER

- The tractor should be sitting with the engine running at full throttle. Move the attachment clutch to the engaged position, starting the snow thrower before the tractor clutch is engaged.

## HOW TO STOP YOUR SNOW THROWER

- To stop the snow thrower, disengage the tractor's attachment clutch lever for manual clutches or the clutch switch for electric clutches. Refer to your tractor owner's manual.

## HOW TO USE YOUR SNOW THROWER



**CAUTION:** Never direct discharge towards bystanders or windows. Do not allow anyone in front of unit.

## CONTROLLING SNOW DISCHARGE

- To control the direction snow is thrown, the discharge chute has 180 degrees of rotation. Turn the crank rod to rotate the chute to the right or the left.
- To control the distance snow is thrown, the upper section of the discharge chute pivots up and down. Push forward on the chute tilt handle to pivot the chute down, decreasing the distance snow is thrown. Pull back on the handle to pivot the chute up, increasing the distance snow is thrown.

**RAISING AND LOWERING**

- Use the toggle switch attached to the side of the tractor's dash to raise or lower the snow thrower. The winch motor will shut off when the snow thrower is in either the up or down position.



**CAUTION:** Do not operate the snow thrower without rear wheel weights attached to the tractor to provide extra traction and stability.

**REMOVING SNOW**

Snow removal conditions vary greatly from light fluffy snowfall to wet heavy snow. Operating instructions must be flexible to fit the conditions encountered. The operator must adapt the lawn tractor and snow thrower to depth of snow, wind direction, temperature and surface conditions.

- Before beginning operation, thoroughly inspect the area of operation and remove all door mats, sleds, boards, wires and other foreign objects.
- The spiral auger speed is directly related to engine speed. For maximum snow removal and discharge, maintain high engine r.p.m. (full throttle). It is advisable to operate the lawn tractor at a slow ground speed (1st gear) for safe and efficient snow removal.
- In deep, drifted or banked snow it will be necessary to use full throttle and a slow ground speed (1st gear). Drive forward into the snow, depress the tractor's clutch-brake pedal and allow the spiral auger to clear the snow. Repeat this method until a path is cleared. On the second pass, overlap the first enough to allow the snow thrower to handle the snow without repeated stopping and starting of forward motion.

- In extremely deep snow, raise the snow thrower up to the transport position to remove the top layer of snow. Drive forward only until the front tires reach the uncleared bottom layer of snow. Stop and allow the snow to clear out of the spiral auger. Back up and then lower the snow thrower to the ground. Drive the tractor forward until the snow again becomes too deep. Repeating this process into and out of drifts will eventually clear even the deepest of snow piles.
- If the snow thrower becomes clogged with snow or jammed with a foreign object, disengage the snow thrower immediately and shut off the tractor engine. Use a wooden stick to unclog the snow thrower before resuming operation.



**DANGER:** Shut off engine and disengage snow thrower before unclogging discharge chute. Unclog using a wooden stick, not your hands.

**OPERATING TIPS**

- Discharge snow down wind whenever possible.
- To help prevent snow from sticking to the snow thrower, allow the snow thrower to reach outdoor temperature before using it. A light coat of wax may also be applied to the inside surface of the snow thrower housing and discharge chute.
- Use tire chains to improve traction.
- Use rear wheel weights to improve traction.
- Before the first snowfall, remove all stones, sticks and other objects which could become hidden by the snow. Permanent obstacles should be marked for visibility.
- Overlap each pass slightly to assure complete snow removal.

**MAINTENANCE**

**CUSTOMER RESPONSIBILITIES**

- Read and follow the maintenance schedule and the maintenance procedures listed in this section.

MAINTENANCE SCHEDULE Fill in dates as you complete regular service.	Service Dates											
	Before each use	After each use	Every season	Before storage								
Check for loose fasteners	X											
Check scraper and shoes for wear	X			X								
Cleaning				X								
Lubrication Section			X									

**LUBRICATION**

- Oil all pivot points on the snow thrower.
- Oil the pivot points of the two idler arms on the clutch/idler assembly.
- Apply penetrating oil to the control cables of the discharge chute.
- Apply a good grade of spray lubricant to the chute tilt control assembly.

**CHECK SCRAPER AND SHOES FOR WEAR  
(Refer to figures 33 and 34 on page 20.)**

- The scraper plate and skid shoes on the bottom of the snow thrower are subject to wear. To prevent damage to the spiral auger housing, replace plate and shoes before wear is excessive.

# SERVICE AND ADJUSTMENTS



**CAUTION:** Before servicing or adjusting the snow thrower, shut off the engine, remove the spark plug wire(s), set the parking brake and remove the key from the tractor ignition.

## REPLACING AUGER BELT

- Disengage the tractor's attachment clutch.
- Lower the snow thrower to the ground.
- Release the spring tension from the auger belt idler arm on the bottom of the clutch/idler assembly.
- Remove the auger drive belt from the clutch/idler assembly and from the spiral auger housing.
- Install new belt over top of large auger drive pulley and under the two side idler pulleys. Twist the belt 1/4 turn to seat the "V" of the belt in the groove of each idler pulley. Refer to figure 29 on page 16.
- Assemble the belt onto the clutch/idler assembly.

## ADJUSTING SKID SHOES

- The skid shoes regulate the distance between the scraper plate and the plowing surface. When removing snow from a gravel driveway or an uneven surface, keep the scraper plate as high above the surface as possible to prevent possible damage to the spiral auger. On a blacktop or concrete surface, keep the scraper plate as close to the surface as possible.
- To adjust the skid shoes, raise the snow thrower off the ground and place a block under each end of the scraper plate. Loosen the six hex nuts securing the skid shoes to the housing. Adjust the skid shoes up or down and retighten the nuts securely. Adjust both skid shoes to the same height to keep the housing and the scraper plate level. See figure 33.

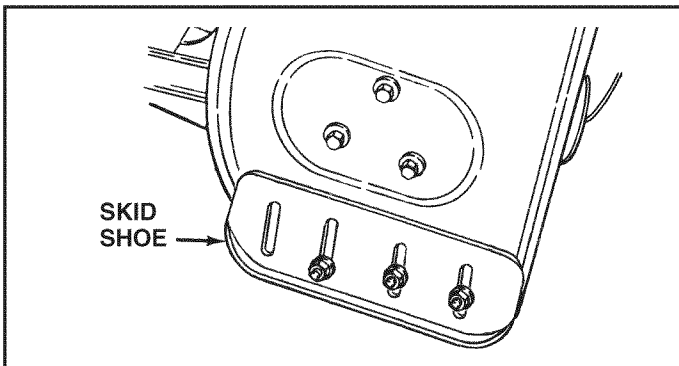

FIGURE 33

## SPIRAL AUGERS

- The spiral augers are secured to the auger shaft with two shear bolts and nylock nuts. The bolts are designed to shear if an object or ice jams the augers.
- If the augers will not turn, check to see if the shear bolts have sheared. See figure 34. Two replacement shear bolts and nylock nuts have been provided with the snow thrower. For future use order part number 710-0890A shear bolt and number 47810 nylock nut.

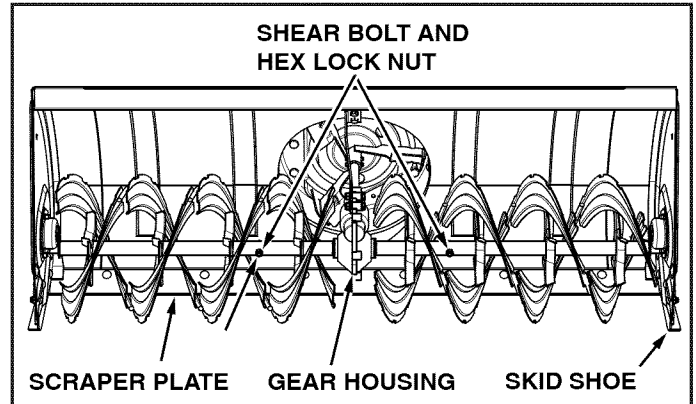

FIGURE 34

## ADJUSTING LIFT HEIGHT, LEVELING

The snow thrower is equipped with two threaded lift links for adjusting the lift height and leveling of the snow thrower in the raised position.

### TO ADJUST THE LIFT HEIGHT:

- Raise the snow thrower to the highest position.
- Check the clearance between the rear of the idler bracket (item 24, page 22) and the lift shaft assembly (item 1, page 24). A minimum 1/16" clearance in the raised position is necessary to avoid possible damage to the lift system.
- To increase the lift height, tighten the nuts on the bottom of both lift links equally until the maximum lift height is obtained. The maximum lift height is approximately 4 inches ground clearance for GT tractors and 3 inches for YT tractors.

### TO LEVEL WHEN RAISED:

- To keep the snow thrower level in the raised position, loosen the nut at the bottom of the lift link on the high side of the snow thrower until the snow thrower is approximately level. It is not critical that the snow thrower be exactly level in the raised position, it will level out when it is lowered to the ground.

## STORAGE

### STORAGE RECOMMENDATIONS

- Lower the snow thrower to the ground.
- Remove the snow thrower from the tractor.
- Clean the snow thrower thoroughly. Wash off any salt deposit which may have dried on the thrower and housing.
- Any bare metal that has become exposed should be painted or coated with a light oil to prevent rust.
- Store in a dry place.

### REMOVING THE SPIRAL AUGER HOUSING

- Lower the snow thrower to the ground.
- Release the spring tension from the auger belt idler arm on the bottom of the clutch/idler assembly.
- Remove the auger drive belt from the clutch/idler assembly. See figure 30 on page 16.
- Disconnect the wires of the snow thrower limit switches from the wire harness attached to the tractor.
- Remove the two clevis pins that attach the snow thrower to the tractor. See figure 26 on page 15.
- Pull the snow thrower off of the front of the tractor.

### PARTS TO REMOVE AT END OF SEASON

- Remove the clutch/idler assembly. (The two hanger brackets and the two shoulder bolts may be left attached to the tractor frame.)
- Remove the drive belt from the engine pulley.
- If a front mounted attachment is to be used, remove the side plates and the winch and bracket assembly from the tractor. Be sure to re-install any bolts that were removed from the tractor frame when the snow thrower was installed.

## TROUBLESHOOTING

PROBLEM	CAUSE	CORRECTION
Spiral augers don't turn	<ol style="list-style-type: none"> <li>1. Upper or lower V belt too loose.</li> <li>2. Upper or lower V belt broken.</li> <li>3. Shear bolts are sheared.</li> </ol>	<ol style="list-style-type: none"> <li>1. Increase tension on V belt.</li> <li>2. Replace V belt.</li> <li>3. Replace shear bolts.</li> </ol>
Clogged discharge chute	<ol style="list-style-type: none"> <li>1. Tractor ground speed too fast .</li> <li>2. Tractor throttle set too low.</li> <li>3. Snow too deep.</li> <li>4. Snow melts during contact with the snow thrower.</li> </ol>	<ol style="list-style-type: none"> <li>1. Use lower tractor gear.</li> <li>2. Increase to full throttle.</li> <li>3. Raise the snow thrower.</li> <li>4. Allow snow thrower to cool to outdoor temperature before using .</li> </ol>
Snow thrower stalls tractor engine	<ol style="list-style-type: none"> <li>1. Object jammed in spiral auger.</li> <li>2. Hard or heavy snow.</li> </ol>	<ol style="list-style-type: none"> <li>1. Stop engine, disengage the snow thrower clutch and clear the auger.</li> <li>2. Increase to full throttle and decrease ground speed.</li> </ol>
Front wheels slide instead of steering	Not enough traction at front wheels.	<ol style="list-style-type: none"> <li>1. Increase scraper plate clearance by lowering skid shoes.</li> </ol>
Snow thrower rides up over snow.	<ol style="list-style-type: none"> <li>1. Tractor ground speed too fast.</li> <li>2. Bottom snow is icy or hard packed.</li> </ol>	<ol style="list-style-type: none"> <li>1. Reduce ground speed.</li> <li>2. Lower the skid shoes so that front of skid shoe is lower than the rear.</li> </ol>

# PARTS

## REPAIR PARTS FOR MODEL 45-0491 50" SNOW THROWER

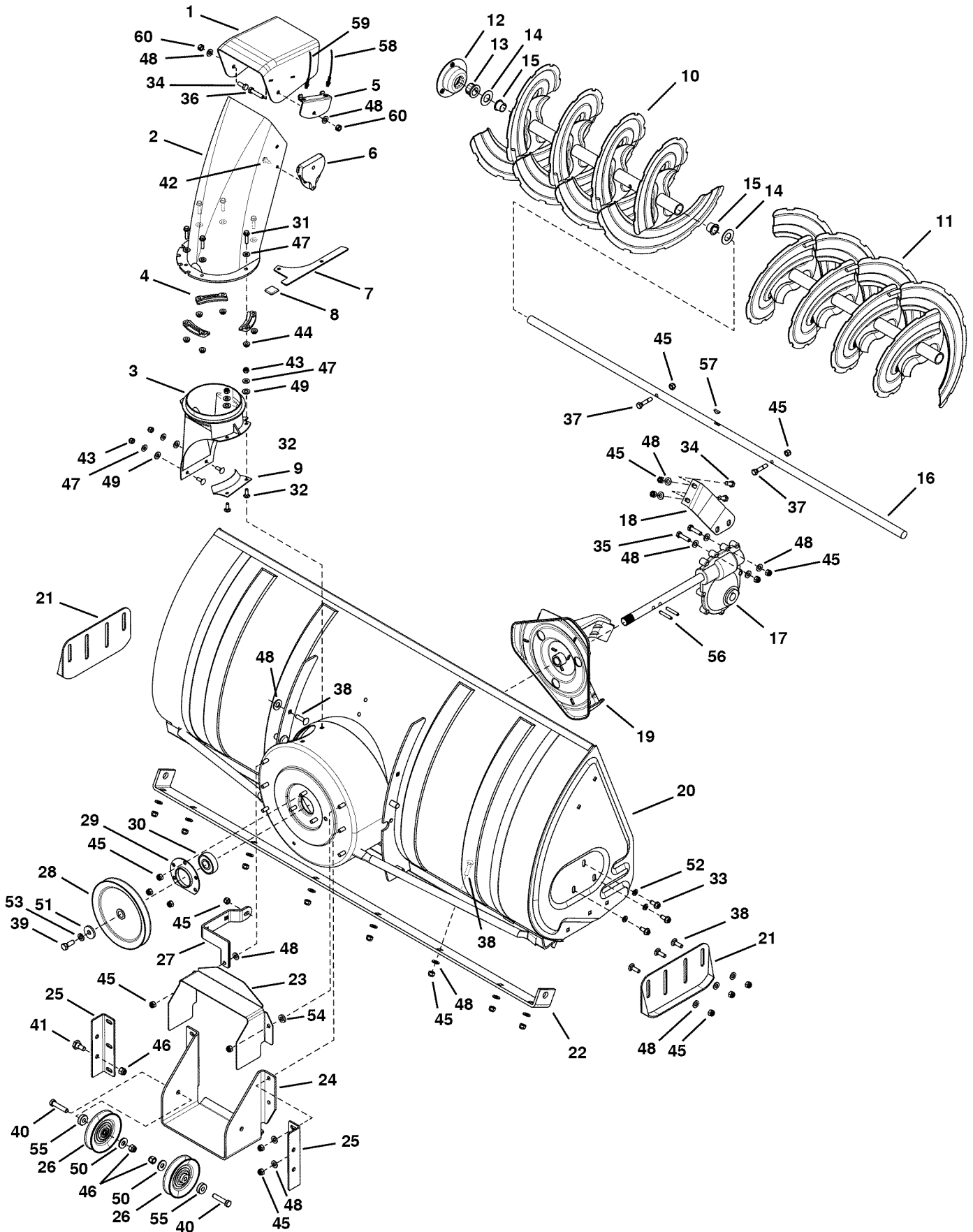

## REPAIR PARTS FOR MODEL 45-0491 50" SNOW THROWER

REF	PART NO	QTY	DESCRIPTION	REF	PART NO	QTY	DESCRIPTION
1	731-0921	1	Chute, Upper	32	44950	4	Carriage Bolt, 1/4-20 x 3/4"
2	731-1300C	1	Chute, Lower	33	47630	6	Bolt, Self-Tap 5/16" x 3/4"
3	731-1379A	1	Chute Adapter	34	43182	3	Hex Bolt, 5/16-18 x 3/4"
4	731-0851A	3	Chute Keeper	35	43840	2	Hex Bolt, 5/16-18 x 1-1/4"
5	784-5594	1	Bracket, Cable	36	43085	1	Hex Bolt, 5/16-18 x 1-1/2"
6	731-1313C	1	Guide, Cable	37	710-0890A	2	Bolt, Shear 5/16-18 x 1-1/2"
7	24394	1	Bracket, Chute Anti-rotation	38	44326	15	Carriage Bolt, 5/16-18 x 1"
8	1643-60	1	Plastic Cap	39	44377	1	Hex Bolt, 3/8-24 x 1"
9	705-5226	1	Chute Reinforcement	40	41576	2	Hex Bolt, 3/8-16 x 1-3/4"
10	65685	1	Spiral Assembly, L.H.	41	48106	2	Bolt, Shoulder
11	65684	1	Spiral Assembly, R.H.	42	710-0896	1	Screw, 1/4-14 x 5/8"
12	784-5618	2	Housing, Bearing	43	47189	4	Hex Nut, 1/4-20 Nylock
13	47615	2	Bearing, Flange	44	47598	6	Hex Lock Nut, 1/4" Flanged
14	43009	6	Washer, .785" x 1.57" x .057"	45	47810	30	Hex Nut, 5/16-18 Nylock
15	741-0493A	4	Bearing, Split, 3/4"	46	HA21362	4	Hex Nut, 3/8-16 Nylock
16	25942	1	Shaft, Auger Gearbox	47	43088	10	Washer, 1/4"
17	71464	1	Gear Assembly	48	43081	28	Washer, 5/16" Std. Wrt.
18	25937	1	Center Brace, Gearbox	49	48015	4	Washer, Nylon
19	63768	1	Impeller Assembly	50	43070	2	Washer, 3/8"
20	65683	1	Housing Assembly	51	736-0247	1	Washer,
21	24279	2	Skid Shoe	52	43086	6	Lock Washer, 5/16"
22	25940	1	Scraper Plate	53	43003	1	Washer, Lock 3/8"
23	24816	1	Cover, Belt	54	750-0437	1	Bushing
24	27280	1	Bracket, Idler	55	711-0242	2	Spacer
25	24466	2	Bracket, Down Stop	56	715-0114	2	Spiral Pin, 1/4" x 1-1/2" Lg.
26	47044	2	Pulley, V Type 4"	57	HA20185	1	#61 Woodruff Key
27	24280	1	Support Tube Bracket	58	746-0929	1	Cable, Chute Control With Clip
28	47026	1	Pulley, V Type	59	746-0928	1	Cable, Chute Control
29	05931	1	Housing, Bearing	60	43064	2	Hex Lock Nut, 5/16-18
30	741-0309	1	Bearing, Ball		42432	1	Owner's Manual
31	43661	6	Hex Bolt, 1/4-20 x 1"				

# REPAIR PARTS FOR MODEL 45-0491 50" SNOW THROWER

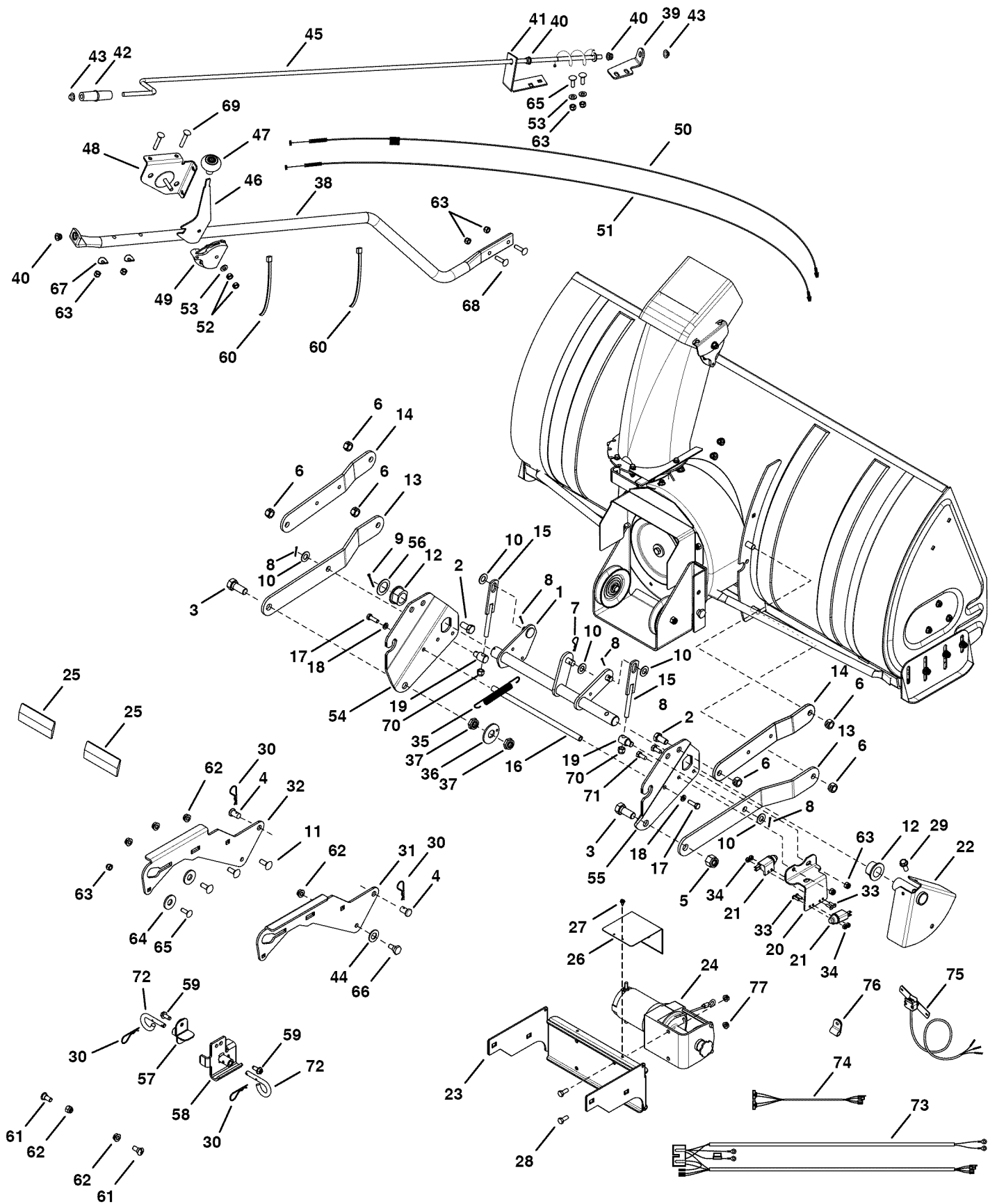



## REPAIR PARTS FOR MODEL 45-0491 50" SNOW THROWER

REF	PART NO	QTY	DESCRIPTION	REF	PART NO	QTY	DESCRIPTION
1	67620	1	Lift Shaft Assembly	40	741-0475	3	Bushing, 3/8" Plastic
2	710-0865	2	Hex Bolt, 1/2-13 x 1"	41	703-2735A	1	Bracket, Chute Crank
3	710-0367	2	Hex Bolt, 5/8-11 x 1-1/2"	42	720-0201A	1	Knob, Crank
4	711-0332	2	Pin, Bracket Lift	43	44917	2	Palnut, 3/8"
5	712-0261	1	Nut, Nylock Hex 5/8-11	44	43070	2	Washer, 3/8"
6	43262	6	Nut, Hex Lock 1/2-13	45	63579	1	Assembly, Chute Crank Rod
7	47134	1	Pin, Hair Cotter 5/64"	46	784-5604A	1	Handle, Chute Tilt
8	142	4	Pin, Cotter 1/8" x 3/4"	47	720-04039	1	Knob
9	43093	1	Pin, Cotter 1/8" x 1-1/2"	48	603-0302	1	Assembly, Chute Tilt Bracket
10	R19171616	5	Washer, 17/32" x 1"	49	731-1313C	1	Guide, Cable
11	43350	6	Carriage Bolt, 3/8-16 x 1"	50	746-0929	1	Cable, Chute Control with Clip
12	741-0192	2	Bearing, Flange With Flats	51	746-0928	1	Cable, Chute Control
13	783-0380	2	Link, 15.80" Long	52	43064	2	Nut, Hex Lock 5/16-18
14	783-0381	2	Link, 11.75" Long	53	43081	3	Washer, 5/16"
15	67598	2	Lift Link	54	24285	1	Plate, Mounting (L.H.)
16	24311	1	Rod, Spacer	55	24284	1	Plate, Mounting (R.H.)
17	47599	2	Hex Bolt, 5/16-18 x 1" (Locking)	56	43601	1	Washer, 1.59" x 1.032" x .060"
18	43086	2	Lock Washer, 5/16"	57	65367	1	Hanger Bracket Assembly, L.H.
19	24807	2	Lift Trunnion	58	65450	1	Hanger Bracket Assembly, R.H.
20	27388	1	Bracket, Stop Switch Mounting	59	46730	2	Bolt, Hex 5/16-18 x 3/4" Self Thd.
21	42553	2	Switch	60	726-0178	9	Tie, Nylon
22	67614	1	Lift Stop Assembly	61	49933	2	Shoulder Bolt, Round Head
23	67628	1	Bracket, Winch Mounting	62	47572	10	Nut, Flanged Lock 3/8-16
24	42570	1	Winch	63	47810	10	Nut, Nylock Hex 5/16-18
25	47788	2	Reflector, Rear	64	R19172410	4	Washer, 1/2"
26	27400	1	Cover, Cable	65	44326	4	Carriage Bolt, 5/16-18 x 1"
27	HA9411666	1	Screw, 10-16 x 1/2"	66	48106	2	Bolt, Shoulder
28	43182	2	Hex Bolt 5/16-18 x 3/4"	67	44695	2	Washer, Bowed
29	47631	1	Bolt, Hex 3/8-16 x 1" Self Thd.	68	43682	2	Carriage Bolt, 5/16-18 x 1-1/4"
30	43343	4	Pin, Haircotter #4 (1/8")	69	44215	2	Carriage Bolt, 5/16-18 x 1-3/4"
31	25678	1	Plate, Side (R.H.)	70	HA21362	2	Hex Nut, 3/8-16 Nylock
32	25679	1	Plate, Side (L.H.)	71	43182	2	Bolt, Hex 5/16-18 x 3/4
33	43346	4	Bolt, Slotted Head 10-32 X 5/8"	72	43038	2	Pin, Pivot Lock
34	47171	4	Nut, Nylock Hex 10-32	73	42554	1	Wire Harness
35	HA20186	1	Spring, Idler	74	42555	1	Wire Harness Extension
36	24564	1	Washer, Special	75	67714	1	Switch Mounting Assembly
37	48714	2	Nut, Nylock Hex Jam 5/8-11	76	HA23761	1	Cable Clip
38	47027	1	Tube, Crank Rod Support	77	49983	2	Nut, Flanged Lock 5/16-18
39	24393	1	Bracket, Chute Crank				

# REPAIR PARTS FOR MODEL 45-0491 50" SNOW THROWER

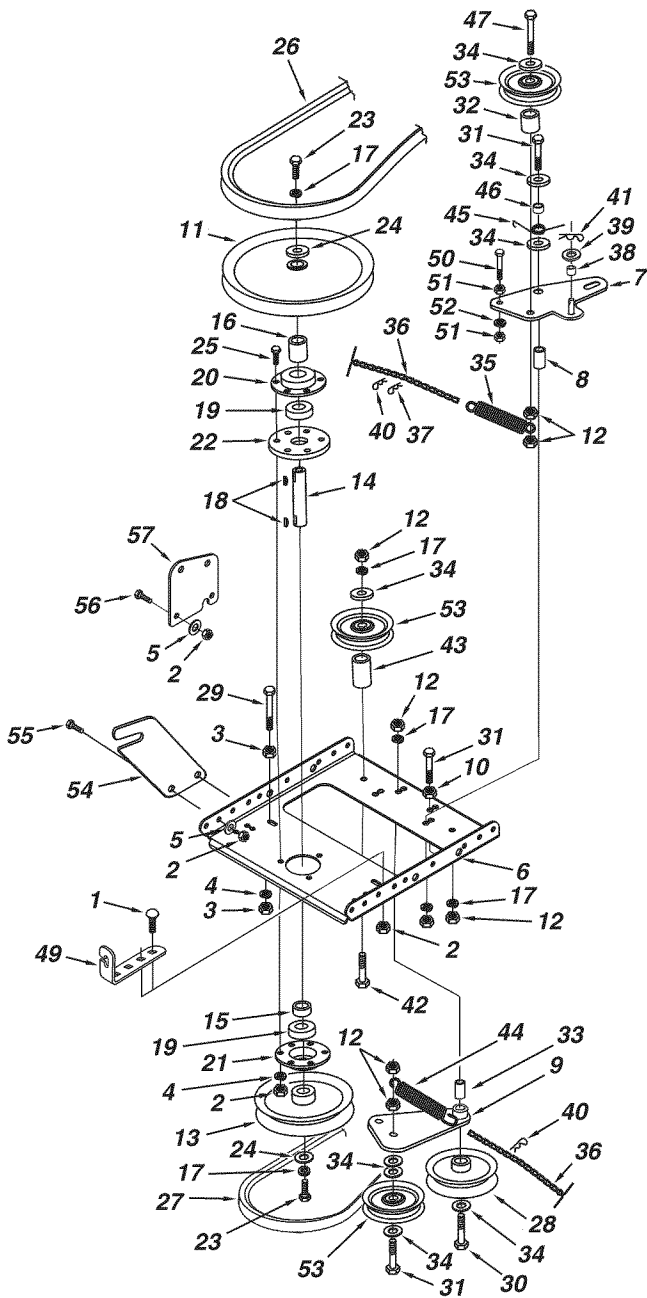

REF	PART NO	QTY	DESCRIPTION
9	63762	1	Idler Bracket Assembly
10	43015	1	Hex Nut, 3/8-16
11	46981	1	Pulley, V Type 9"
12	43082	8	Nut, Hex Lock, 3/8-16
13	46982	1	Pulley, V Type 5-1/2"
14	738-0680	1	Shaft
15	750-0456	1	Spacer
16	750-0660	1	Spacer
17	43003	6	Lock Washer, 3/8"
18	714-0161	2	Key
19	741-0919	2	Bearing, Ball
20	08253B	1	Housing, Bearing
21	15296A	1	Housing, Open Bearing
22	14088B	1	Spacer, Spindle
23	44377	2	Hex Bolt, 3/8-24 x 1"
24	736-0247	2	Washer
25	43063	3	Hex Bolt, 5/16-18 x 1"
26	46989	1	Belt, V Type Drive (55")
	48138	1	Belt, V Type Drive (56")
27	47846	1	Belt, V Type Auger
28	47044	1	Pulley, V Type 4"
29	47025	1	Hex Bolt, 5/16-18 x 3-1/2"
30	43432	1	Hex Bolt, 3/8-16 x 2-1/2"
31	43054	3	Hex Bolt, 3/8-16 x 2"
32	24571	1	Spacer
33	24472	1	Spacer, Pivot
34	43070	8	Washer, 3/8"
35	46959	1	Spring
36	46963	2	Chain
37	43055	1	Pin, Hair Cotter, 3/32"
38	23727	1	Spacer
39	43088	1	Washer, 1/4"
40	43343	2	Pin, Hair Cotter #4 (1/8")
41	47134	1	Pin, Hair Cotter 5/64"
42	46938	1	Hex Bolt, 3/8-16 x 3-1/4"
43	25780	1	Spacer
44	47620	1	Spring
45	47607	1	Spring, Torsion
46	23625	1	Spacer
47	43509	1	Hex Bolt, 3/8-16 x 2-3/4" Lg.
48	47605	1	Washer, Flat 3/8"
49	24558	1	Cable Bracket
50	49870	1	Hex Bolt, 1/4-20 x 2-1/2"
51	43178	2	Hex Nut, 1/4-20
52	43177	1	Lock Washer, 1/4"
53	48883	3	Pulley, Flat 3-5/8"
54	25728	2	Rear Pulley Frame Bracket
55	43182	4	Hex Bolt, 5/16-18 x 3/4"
56	43063	4	Hex Bolt, 5/16-18 x 1"
57	27016	2	Front Pulley Frame Bracket

REF	PART NO	QTY	DESCRIPTION
1	43080	1	Carriage Bolt, 5/16-18 x 3/4"
2	47810	12	Hex Nut, 5/16-18 Nylock
3	43083	2	Hex Nut, 5/16-18
4	43086	4	Lock Washer, 5/16"
5	43081	12	Washer, 5/16" Std. Wrt.
6	26943	1	Frame, Clutch and Pulley
7	63904	1	Idler Arm Assembly
8	24286	1	Spacer, Pivot

# SLOPE GUIDE

(Keep this sheet in a safe place for future reference.)  
Use this guide to determine if a slope is safe for the operation of your tractor and snow thrower. Refer also to the instructions in your vehicle owners manual.

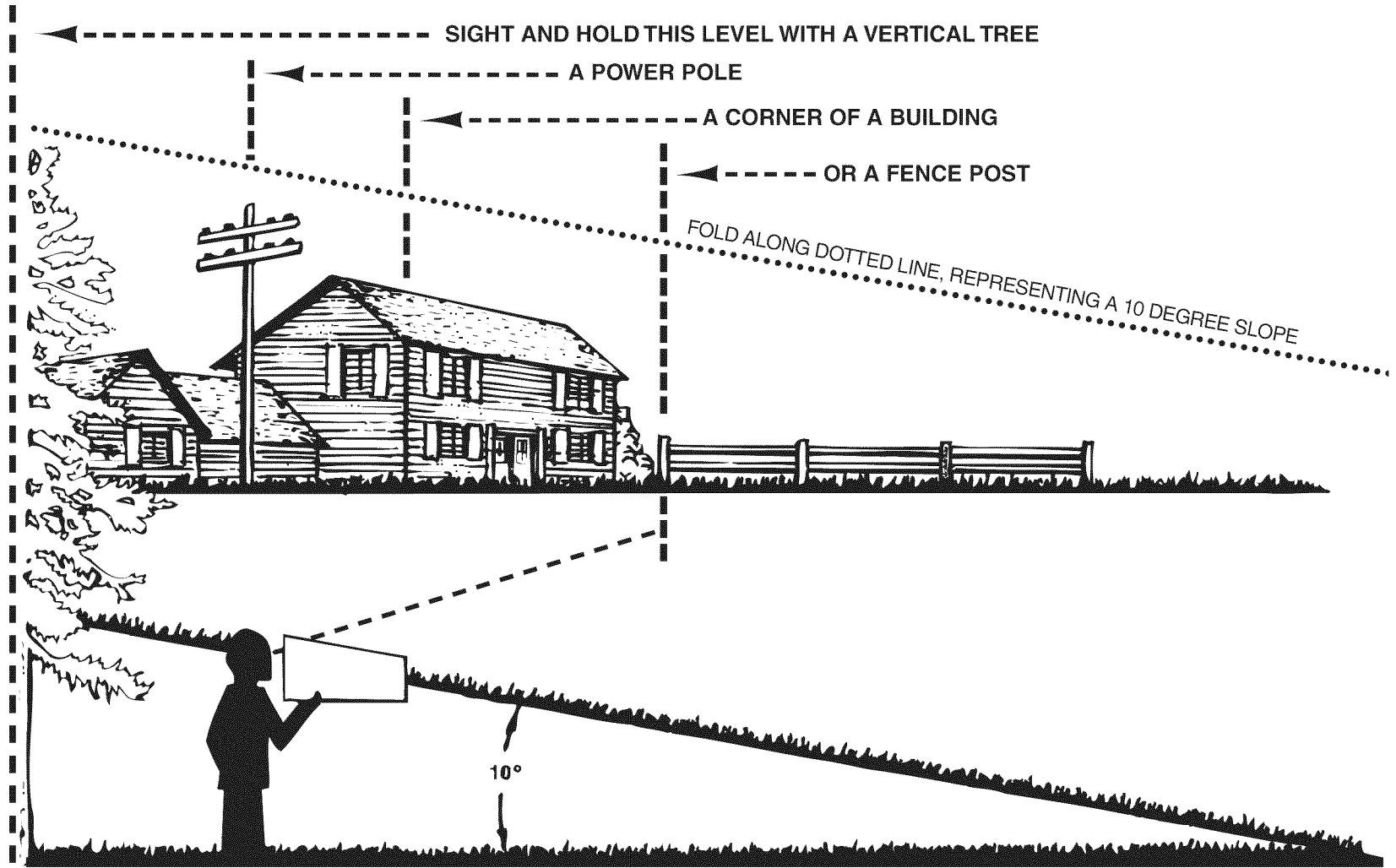

**CAUTION: DO NOT OPERATE YOUR TRACTOR AND SNOW THROWER ON A SLOPE IN EXCESS OF 10 DEGREES. BE SURE OF YOUR TRACTOR'S TOWING AND BRAKING CAPABILITIES BEFORE OPERATING ON A SLOPE. AVOID ANY SUDDEN TURNS OR MANEUVERS WHILE ON A SLOPE.**

***SpeedEPart*** *the fastest way to purchase parts* [www.speedepart.com](http://www.speedepart.com)

**REPAIR PARTS**

Agri-Fab, Inc.  
809 South Hamilton  
Sullivan, IL. 61951  
217-728-8388  
[www.agri-fab.com](http://www.agri-fab.com)