

PRO-FORM[®]

CROSSWALKFIT 415

Model No. 831.24853.1

Serial No. _____

Write the serial number in the space above for reference.

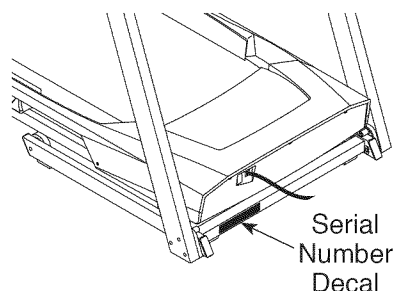

- Assembly
- Operation
- Maintenance
- Part List and Drawing

Sears, Roebuck and Co.
Hoffman Estates, IL 60179

⚠ CAUTION

Read all precautions and instructions in this manual before using this equipment. Keep this manual for future reference.

TREADMILL EXERCISER

User's Manual



TABLE OF CONTENTS

WARNING DECAL PLACEMENT 2

IMPORTANT PRECAUTIONS 3

BEFORE YOU BEGIN 5

PART IDENTIFICATION CHART 6

ASSEMBLY 7

OPERATION AND ADJUSTMENT 14

HOW TO FOLD AND MOVE THE TREADMILL 20

TROUBLESHOOTING 21

EXERCISE GUIDELINES 23

PART LIST 27

EXPLODED DRAWING 28

ORDERING REPLACEMENT PARTS Back Cover



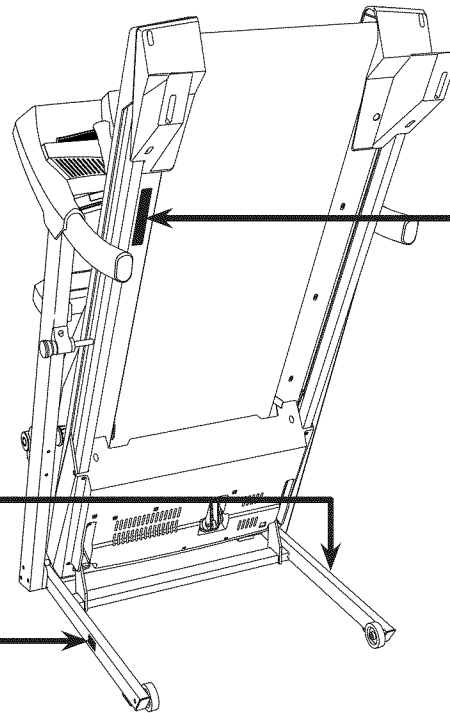

90-DAY FULL WARRANTY Back Cover

WARNING DECAL PLACEMENT

This drawing shows the locations of the warning decals. **If a decal is missing or illegible, call 1-888-533-1333 and request a free replacement decal. Apply the decal in the location shown.** Note: The decals may not be shown at actual size.



▲WARNING:
Protect yourself and others from risk of serious injury. Read the user's manual, and:

-  Stand only on the side rails when starting or stopping treadmill.
- Change speed in small increments.
- Hold handrails to prevent falling, and always wear the safety clip while operating the treadmill.
- Stop if you feel faint, dizzy, or short of breath.
- Fully engage the storage latch before the treadmill is moved or stored.
- Incline should be set to zero before folding the treadmill into a storage position.
-  Never allow children on or around the treadmill.
-  Remove the safety key when treadmill is not in use.
-  Keep clothing, fingers, and hair away from moving parts.
- Never try to adjust or fix the belt while it is moving.
-  Always wear athletic shoes while operating the treadmill.

IMPORTANT PRECAUTIONS

⚠️ WARNING: To reduce the risk of burns, fire, electric shock, or injury to persons, read all important precautions and instructions in this manual and all warnings on your treadmill before using your treadmill. Sears assumes no responsibility for personal injury or property damage sustained by or through the use of this product.

1. It is the responsibility of the owner to ensure that all users of this treadmill are adequately informed of all warnings and precautions.
2. Before beginning any exercise program, consult your physician. This is especially important for persons over age 35 or persons with pre-existing health problems.
3. Use the treadmill only as described in this manual.
4. The treadmill is intended for home use only. Do not use the treadmill in any commercial, rental, or institutional setting.
5. Keep the treadmill indoors, away from moisture and dust. Do not put the treadmill in a garage or covered patio, or near water.
6. Place the treadmill on a level surface, with at least 8 ft. (2.4 m) of clearance behind it and 2 ft. (0.6 m) on each side. Do not place the treadmill on any surface that blocks air openings. To protect the floor or carpet from damage, place a mat under the treadmill.
7. Do not operate the treadmill where aerosol products are used or where oxygen is being administered.
8. Keep children under age 12 and pets away from the treadmill at all times.
9. The treadmill should be used only by persons weighing 300 lbs. (136 kg) or less.
10. Never allow more than one person on the treadmill at a time.
11. Wear appropriate exercise clothes while using the treadmill. Do not wear loose clothes that could become caught in the treadmill. Athletic support clothes are recommended for both men and women. *Always wear athletic shoes. Never use the treadmill with bare feet, wearing only stockings, or in sandals.*
12. Plug the power cord into a surge suppressor (not included), and plug the surge suppressor into an appropriate outlet (see page 14). To avoid overloading the circuit, do not plug other electrical devices, except for low-power devices such as cell phone chargers, into the surge suppressor or into an outlet on the same circuit.
13. Use only a surge suppressor that meets all of the specifications described on page 14. To purchase a surge suppressor, see your local Sears store, call the telephone number on the back cover of this manual, or see your local electronics store.
14. Failure to use a properly functioning surge suppressor could result in damage to the control system of the treadmill. If the control system is damaged, the walking belt may slow, accelerate, or stop unexpectedly, which may result in a fall and serious injury.
15. Keep the power cord and the surge suppressor away from heated surfaces.
16. Never move the walking belt while the power is turned off. Do not operate the treadmill if the power cord or plug is damaged, or if the treadmill is not working properly. (See TROUBLESHOOTING on page 21 if the treadmill is not working properly.)
17. Read, understand, and test the emergency stop procedure before using the treadmill (see HOW TO TURN ON THE POWER on page 16).
18. Never start the treadmill while you are standing on the walking belt. Always hold the handrails while using the treadmill.
19. The treadmill is capable of high speeds. Adjust the speed in small increments to avoid sudden jumps in speed.

20. The heart rate monitor is not a medical device. Various factors, including the user's movement, may affect the accuracy of heart rate readings. The heart rate monitor is intended only as an exercise aid in determining heart rate trends in general.
21. Never leave the treadmill unattended while it is running. Always remove the key, press the power switch into the off position (see the drawing on page 5 for the location of the power switch), and unplug the power cord when the treadmill is not in use.
22. Do not attempt to move the treadmill until it is properly assembled. (See ASSEMBLY on page 8 and HOW TO FOLD AND MOVE THE TREADMILL on page 20.) You must be able to safely lift 45 lbs. (20 kg) to move the treadmill.
23. When folding or moving the treadmill, make sure that the storage latch is holding the frame securely in the storage position.
24. Do not change the incline of the treadmill by placing objects under the treadmill.
25. Never insert any object into any opening on the treadmill.
26. Inspect and properly tighten all parts of the treadmill regularly.
27. **DANGER:** Always unplug the power cord immediately after use, before cleaning the treadmill, and before performing the maintenance and adjustment procedures described in this manual. Never remove the motor hood unless instructed to do so by an authorized service representative. Servicing other than the procedures in this manual should be performed by an authorized service representative only.
28. Over exercising may result in serious injury or death. If you feel faint or if you experience pain while exercising, stop immediately and cool down.

SAVE THESE INSTRUCTIONS

BEFORE YOU BEGIN

Thank you for selecting the new PROFORM® CROSSWALK FIT 415 treadmill. The CROSSWALK FIT 415 treadmill provides an impressive selection of features designed to make your workouts at home more effective and enjoyable.

For your benefit, read this manual carefully before you use the treadmill. If you have questions after

reading this manual, please see the back cover of this manual. To help us assist you, note the product model number and serial number before contacting us. The model number and the location of the serial number decal are shown on the front cover of this manual.

Before reading further, please familiarize yourself with the parts that are labeled in the drawing below.

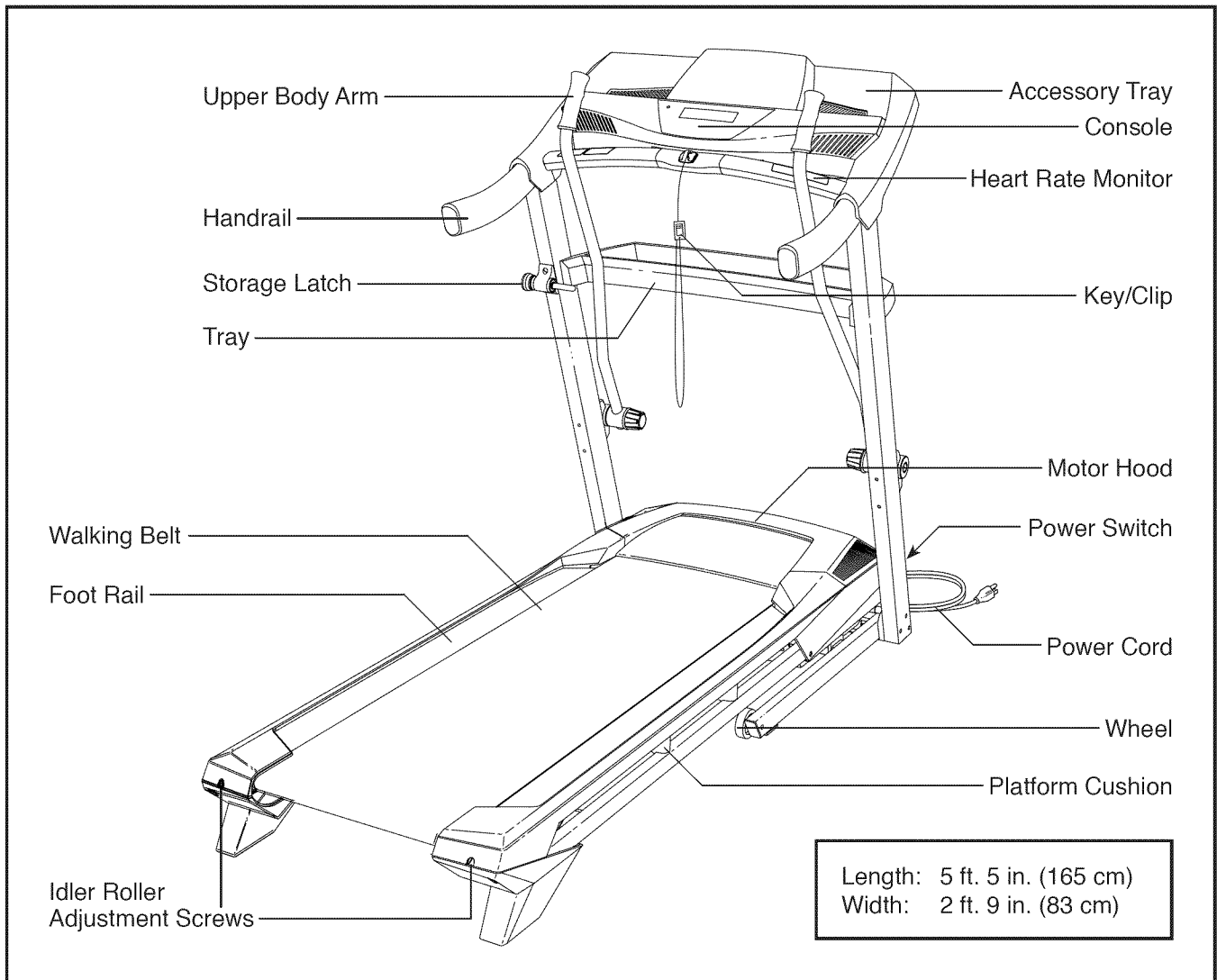

PART IDENTIFICATION CHART

Use the drawings below to identify small parts used for assembly. The number in parentheses below each drawing is the key number of the part, from the PART LIST near the end of this manual. The number following the key number is the quantity used for assembly. **Note: If a part is not in the hardware kit, check to see if it is pre-attached. If it is not, call 1-888-533-1333. Extra parts may be included.**



1/4" External Star Washer (61)—8

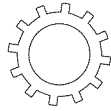

5/16" Star Washer (6)—4

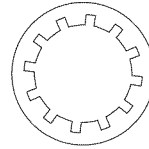

3/8" Star Washer (3)—10

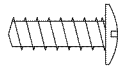

#8 x 1/2" Ground Screw (1)—1

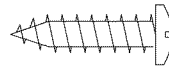

#8 x 3/4" Screw (4)—14

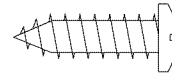

#10 x 3/4" Screw (8)—2

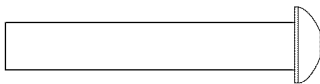

1/4" x 1 1/4" Screw (77)—4

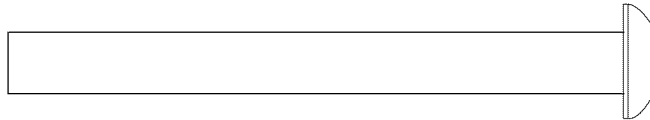

5/16" x 3 1/5" Screw (78)—4

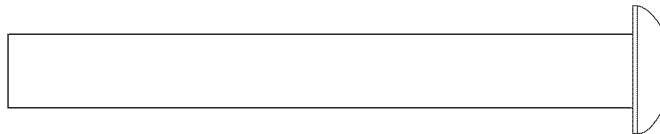

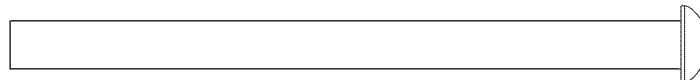

3/8" x 3 1/4" Screw (2)—6



1/4" x 3 1/2" Screw (33)—4

ASSEMBLY

- Assembly requires two persons.
 - Place all parts in a cleared area and remove the packing materials. Do not dispose of the packing materials until you finish all assembly steps.
 - After shipping, there may be an oily substance on the exterior of the treadmill. This is normal. If there is an oily substance on the treadmill, wipe it off with a soft cloth and a mild, non-abrasive cleaner.
 - Left parts are marked "L" or "Left" and right parts are marked "R" or "Right."
 - To identify small parts, see page 6.
 - Assembly requires the following tools:
 - the included hex key 
 - one Phillips screwdriver 
- To avoid damaging parts, do not use power tools.

1. **Go to www.proformservice.com registration on your computer and register your product.**

- activates your warranty
- saves you time if you ever need to contact Customer Care
- allows us to notify you of upgrades and offers

Note: If you do not have Internet access, call 1-888-533-1333 and register your product.

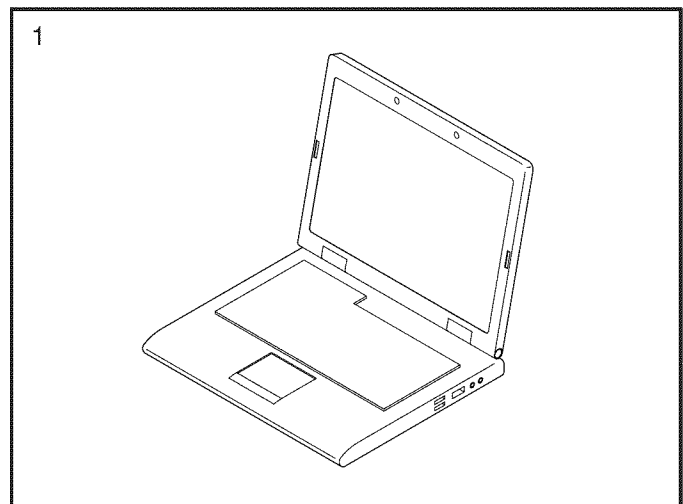

2. **Make sure that the power cord is unplugged.**

Remove and discard the two screws (A) and the shipping bracket (B) from the right side of the Base (74). **Then, remove and discard the screws and the shipping bracket (not shown) from the left side of the Base.**

Remove the tie securing the Upright Wire (63).

Press a Base Cap (70) into each side of the Base (74) (only one side is shown).

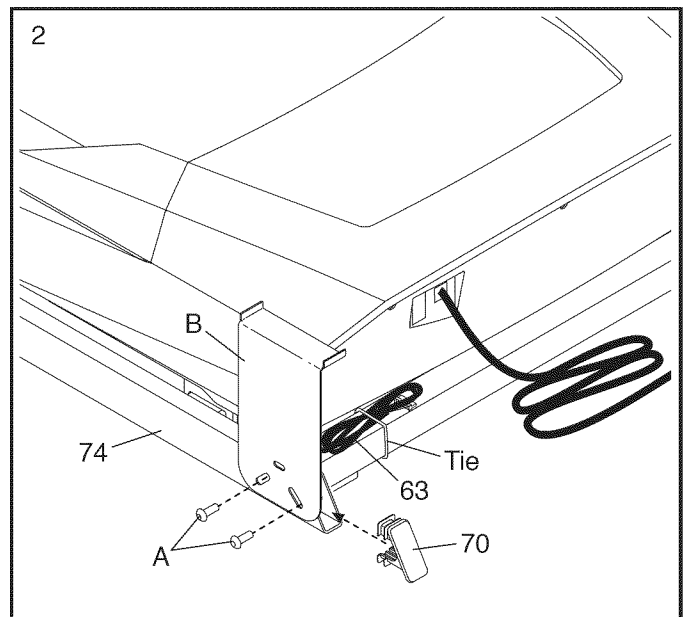

3. Identify the Right Upright (76). Have a second person hold the Right Upright near the Base (74).

See the inset drawing. Tie the wire tie in the Right Upright (76) securely around the end of the Upright Wire (63). Then, insert the Upright Wire into the lower end of the Right Upright as you pull the other end of the wire tie out of the Right Upright.

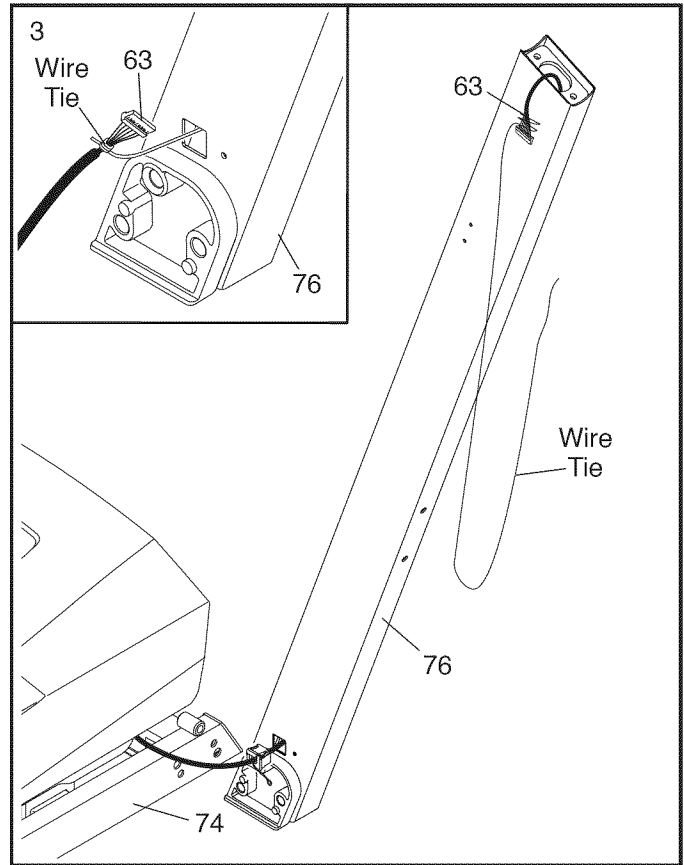

4. Lay the Right Upright (76) near the Base (74) as shown. Attach the ground wire to the Base with a #8 x 1/2" Ground Screw (1).

Then, press the Upright Grommet (73) into the square hole in the Right Upright (76).

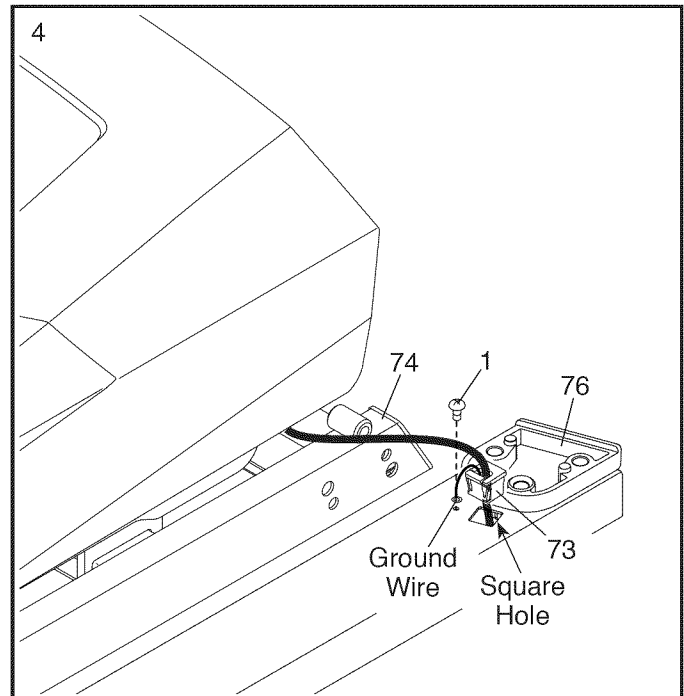

5. Hold the Right Upright (76) against the Base (74). **Be careful not to pinch the Upright Wire (63).**

Insert a 3/8" x 3 1/4" Screw (2) with a 3/8" Star Washer (3) into the top hole in the Right Upright (76). Then, partially tighten the Screw into the Base (74).

Partially tighten two more 3/8" x 3 1/4" Screws (2) with two 3/8" Star Washers (3) into the Right Upright (76) and the Base (74); **do not fully tighten the Screws yet.**

Attach the Left Upright (not shown) in the same way. Note: There are no wires on the left side.

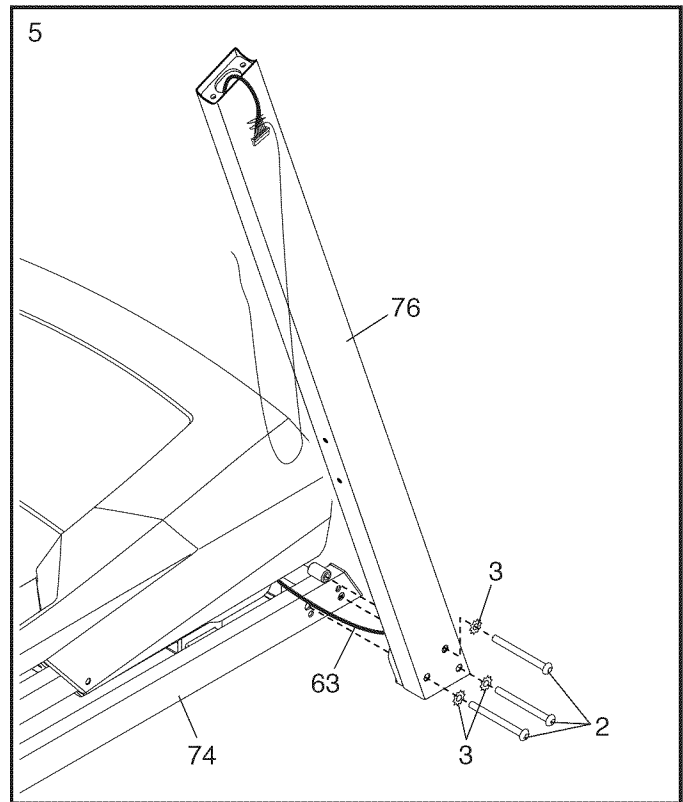

6. Identify the Left and Right Handrails (59, 64). **(Note: The Right Handrail has a large hole in its side.)** Insert the Console Frame (7) into the Left and Right Handrails. **Note: The nut inserts (C) should be on the bottom.**

Tighten two 1/4" x 1 1/4" Screws (77) with two 1/4" External Star Washers (61) into each Handrail (59, 64) and into the Console Frame (7); **do not fully tighten the Screws yet.**

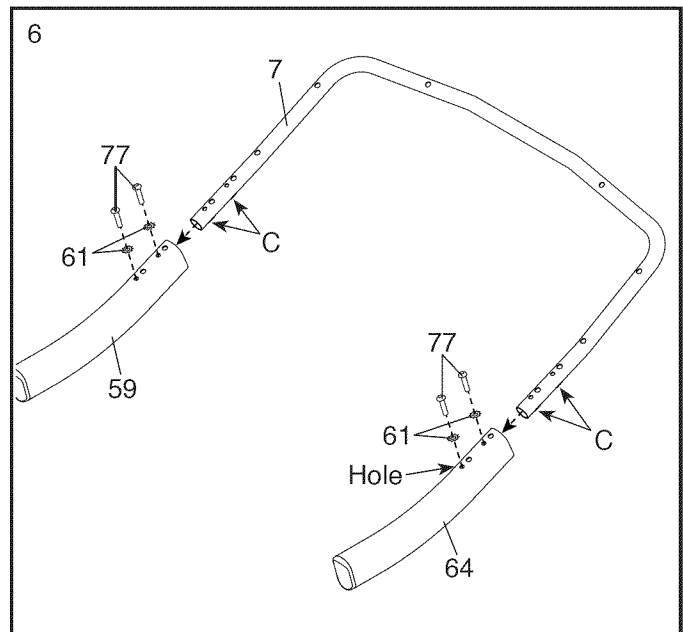

7. Hold the Handrails (59, 64) near the Uprights (66, 76).

Route the Upright Wire (63) into the bottom of the Right Handrail (64) and out of the hole in the side of the Right Handrail.

Set the Handrails (59, 64) on the Uprights (66, 76). **Be careful not to pinch the Upright Wire (63).** Partially tighten four 5/16" x 3 1/5" Screws (78) with four 5/16" Star Washers (6) through the Handrails and into the Uprights. **Start all four Screws, then tighten them.**

Tighten the four 1/4" x 1 1/4" Screws (77).

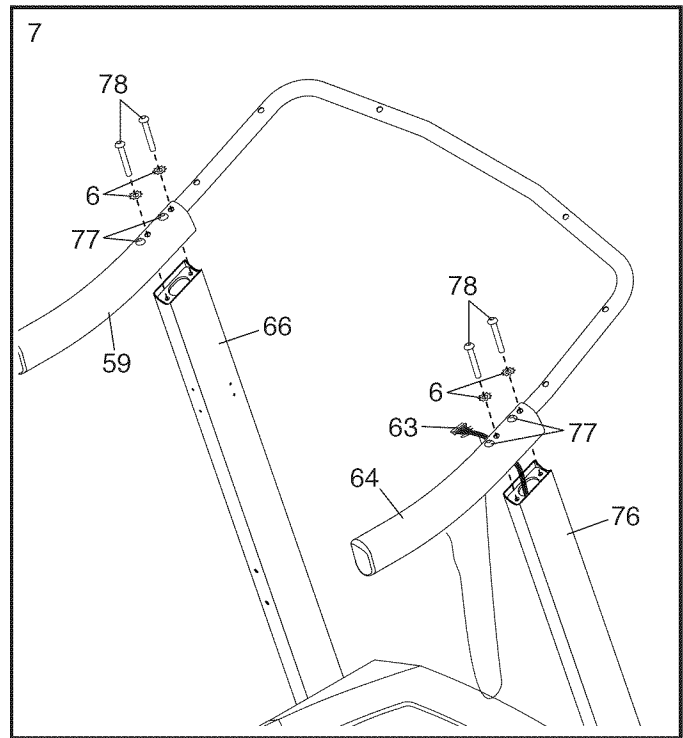

8. With the help of a second person, hold the console assembly near the Right Handrail (64).

Connect the Upright Wire (63) to the console wire. **See the inset drawing. The connectors should slide together easily and snap into place.** If they do not, turn one connector and try again. **IF YOU DO NOT CONNECT THE CONNECTORS PROPERLY, THE CONSOLE MAY BECOME DAMAGED WHEN YOU TURN ON THE POWER.** Then, remove the wire tie from the Upright Wire.

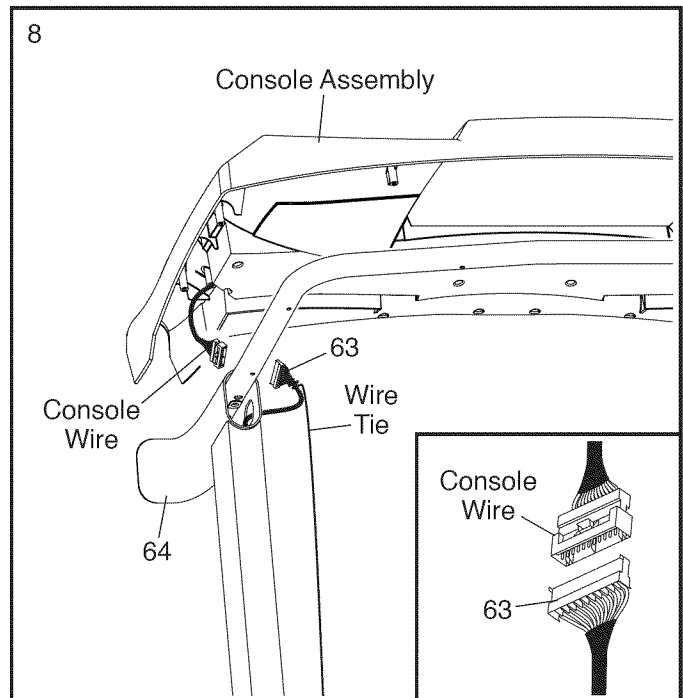

9. Connect the ground wire (D) from the console assembly to the Console Ground Wire (79).

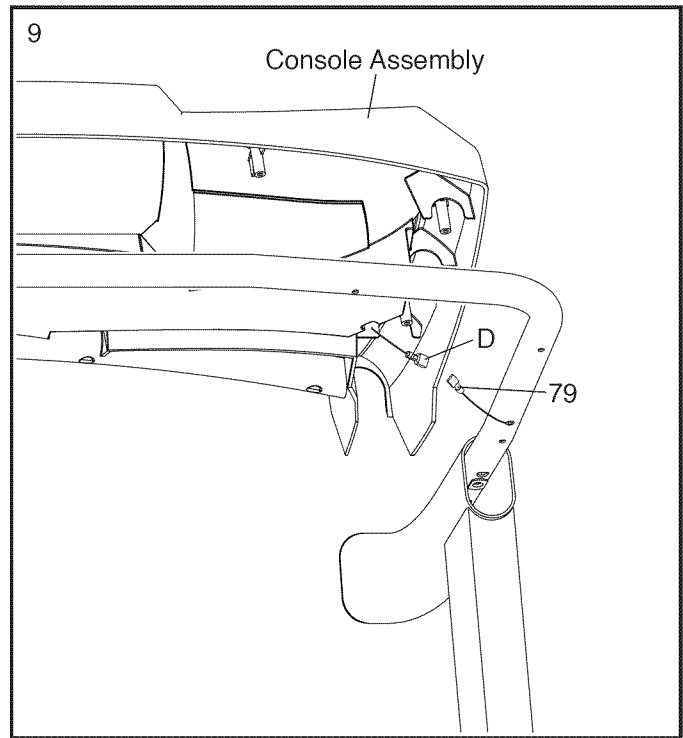

10. Insert the Upright Wire (63) into the Right Handrail (64) through the indicated hole as you set the console assembly on the Uprights (66, 76). **Make sure that no wires are pinched.**

Attach the console assembly with six #8 x 3/4" Screws (4). **Start all six Screws, and then tighten them. Do not overtighten the Screws.**

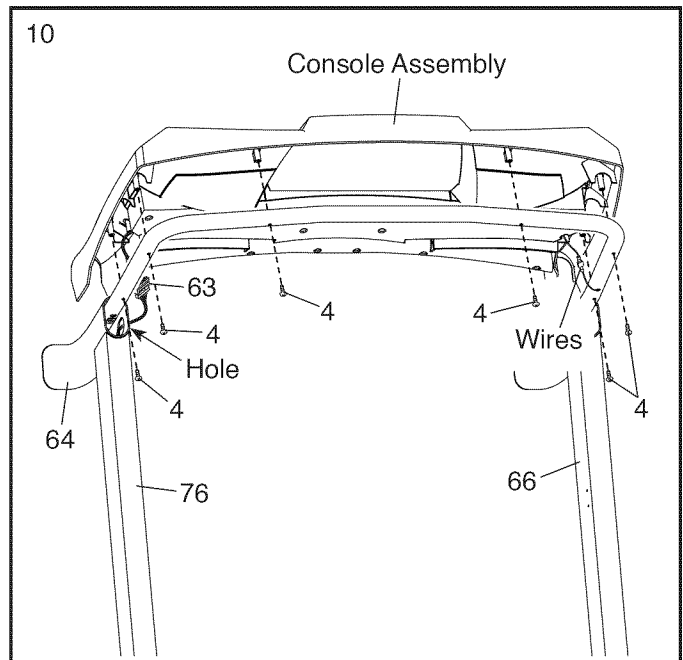

11. **Orient the Latch Housing (67) so that the large hole is on the indicated side.** Attach the Latch Housing to the Left Upright (66) with two #10 x 3/4" Screws (8); **start both Screws, and then tighten them.**

Locate the Latch Pin Assembly (68). Remove the knob from the pin. Make sure that the collar and the spring are on the pin. (Note: If there are two collars, place one on each side of the spring.) Next, insert the pin into the Latch Housing (67). Then, tighten the knob onto the pin.

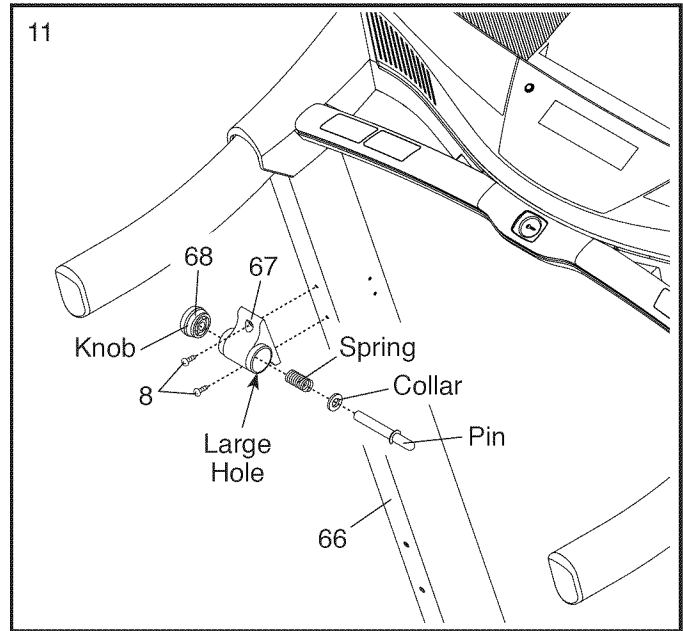

12. Attach the Left and Right Tray Brackets (83, 84) to the Uprights (66, 76) with four #8 x 3/4" Screws (4).

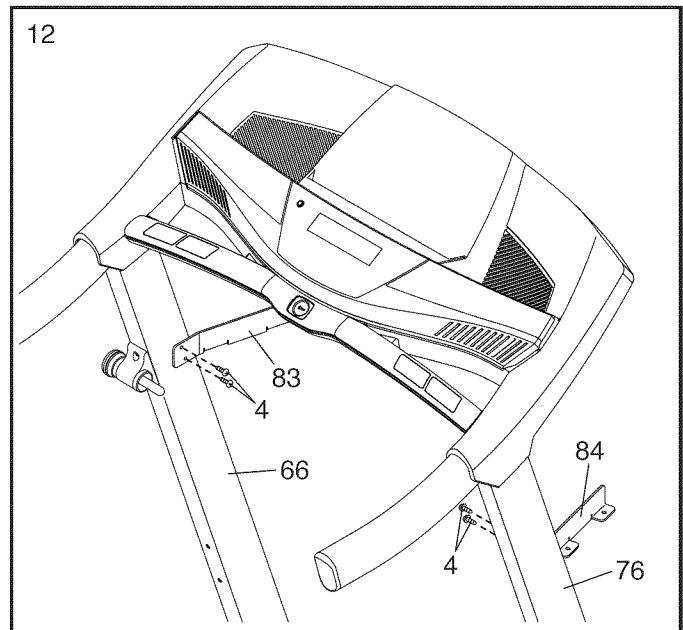

13. Attach the Tray (86) with four #8 x 3/4" Screws (4). **Start all four Screws, and then tighten them.**

Tighten the six 3/8" x 3 1/4" Screws (2).

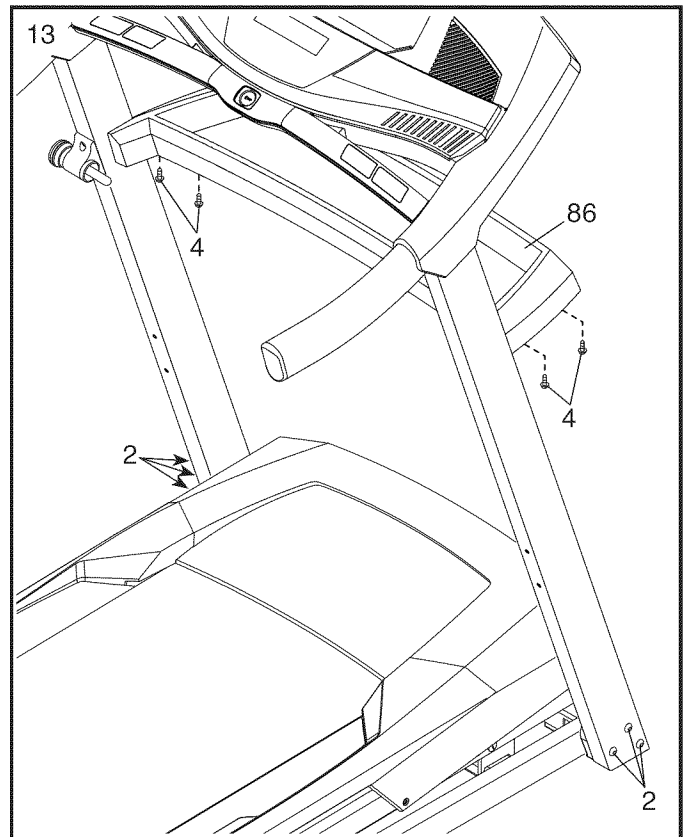

14. Identify the Left and Right Upper Body Arms (81, 82).

Position the Right Upper Body Arm (82) as shown. Attach the Right Upper Body Arm to the Right Upright (76) with two 1/4" x 3 1/2" Screws (33), two 1/4" External Star Washers (61), and two 3/8" Star Washers (3) as shown. **Do not overtighten the Screws.**

Attach the Left Upper Body Arm (81) in the same way.

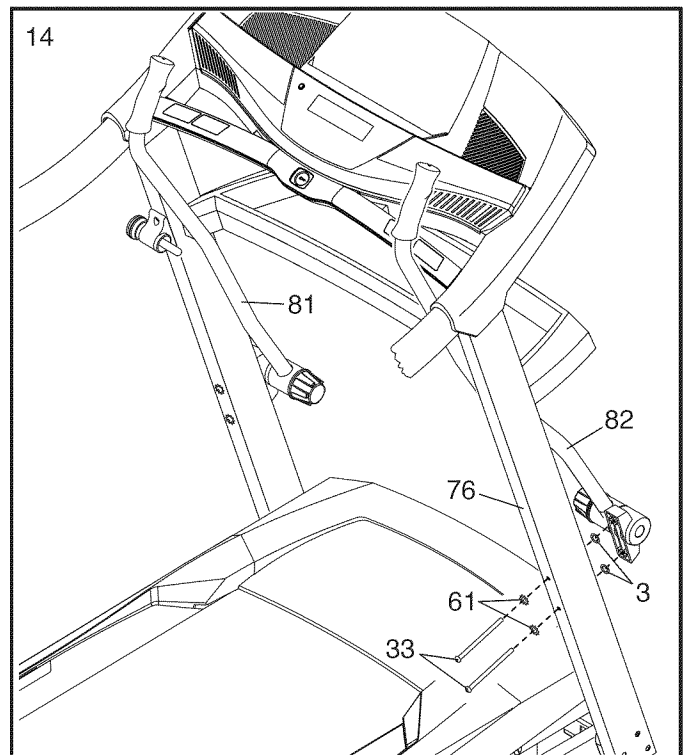

15. **Make sure that all parts are properly tightened before you use the treadmill.** If there are sheets of plastic on the treadmill decals, remove the plastic. To protect the floor or carpet, place a mat under the treadmill. Note: Extra hardware may be included. Keep the included hex keys in a secure place; one of the hex keys is used to adjust the walking belt (see page 22).

OPERATION AND ADJUSTMENT

HOW TO CONNECT THE POWER CORD

Use a Surge Suppressor

Your treadmill, like other electronic equipment, can be damaged by sudden voltage changes in your home's power. Voltage surges, spikes, and noise interference can result from weather conditions or from other appliances being turned on or off. **To decrease the risk of damaging the treadmill, always use a surge suppressor with the treadmill. To purchase a surge suppressor, see precaution 13 on page 3.**

Use only a surge suppressor that is UL 1449 listed as a transient voltage surge suppressor (TVSS). The surge suppressor must have a UL suppressed voltage rating of 400 volts or less and a minimum surge dissipation of 450 joules. The surge suppressor must also be electrically rated for 120 volts AC and 15 amps. There must be a monitoring light on the surge suppressor to indicate whether it is functioning properly. **Failure to use a properly functioning surge suppressor could result in damage to the control system of the treadmill and serious injury to users.**

Plug in the Power Cord

The treadmill must be grounded. If it should malfunction or break down, grounding provides a path of least resistance for electric current to reduce the risk of electric shock. The treadmill power cord has a plug with a grounding pin (see drawing 1 on this page).

⚠ DANGER: Improper connection of the power cord increases the risk of electric shock. Do not modify the plug—if it will not fit an outlet, have a proper outlet installed by a qualified electrician. If you are unsure whether the treadmill is properly grounded, contact a qualified electrician.

Plug the power cord into a surge suppressor, and plug the surge suppressor into an appropriate outlet that is properly installed and grounded in accordance with all local codes and ordinances. **The outlet must be on a**

nominal 120-volt circuit capable of carrying 15 or more amps. To avoid overloading the circuit, do not plug other electrical devices, except for low-power devices such as cell phone chargers, into the surge suppressor or into an outlet on the same circuit. **IMPORTANT: The treadmill is not compatible with GFCI-equipped outlets and may not be compatible with AFCI-equipped outlets.**

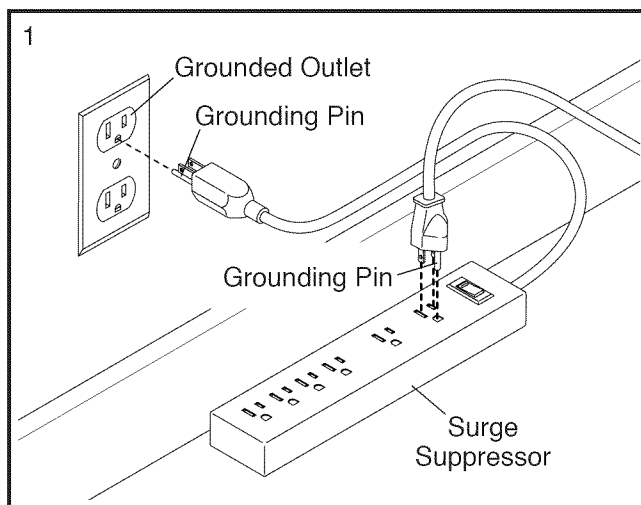

A temporary adapter may be used to connect the surge suppressor to a 2-pole receptacle if a properly grounded outlet is not available.

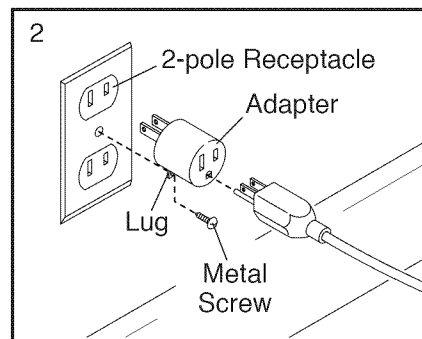

The lug or wire extending from the adapter must be connected with a metal screw to a permanent ground such as a properly grounded outlet box cover. **Some 2-pole receptacle outlet box covers are not grounded. Before using an adapter, contact a qualified electrician to determine whether the outlet box cover is grounded. The temporary adapter should be used only until a properly grounded outlet can be installed by a qualified electrician.**

CONSOLE DIAGRAM

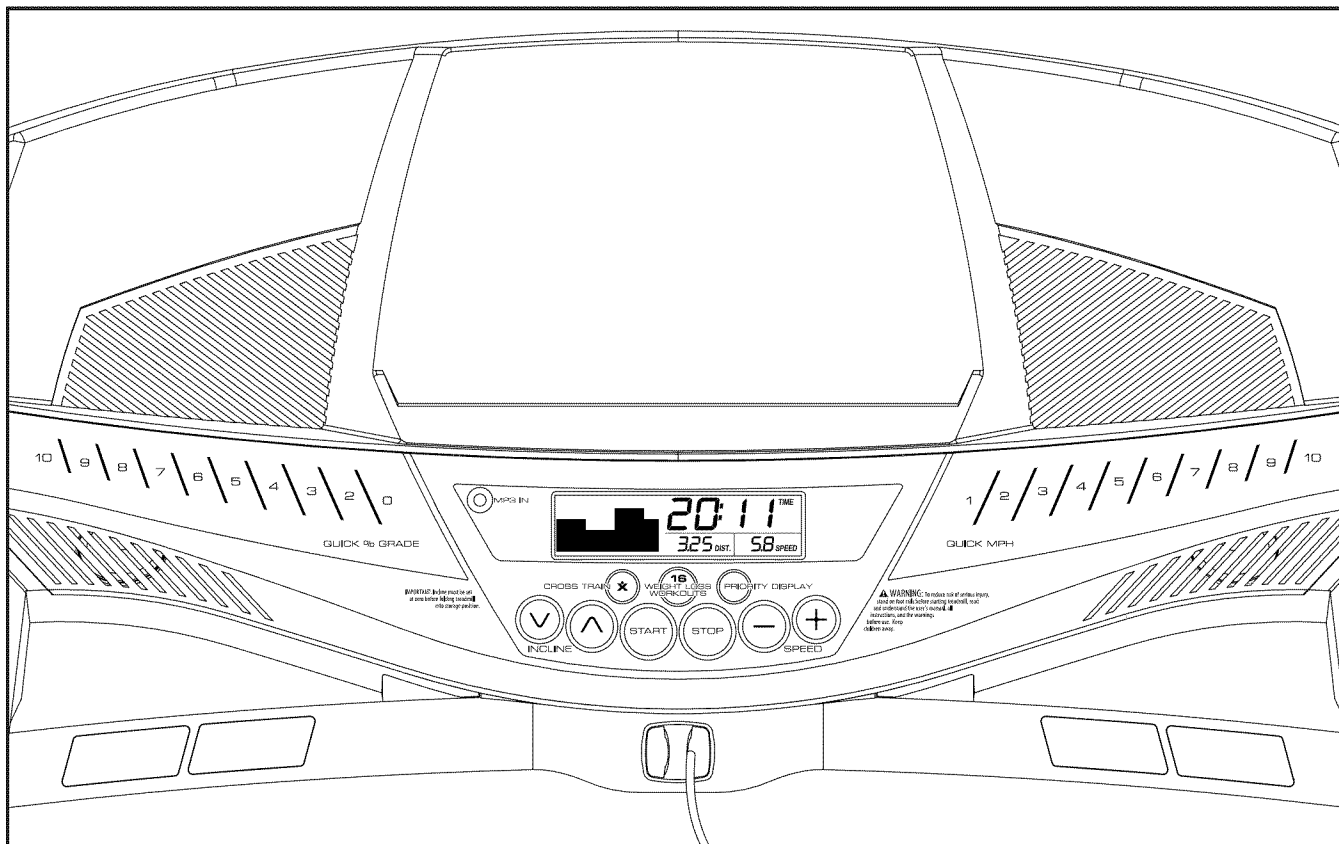

FEATURES OF THE CONSOLE

The treadmill console offers a selection of features designed to make your workouts more effective and enjoyable. When you select the manual mode of the console, you can change the speed and incline of the treadmill with the touch of a button. As you exercise, the console will display continuous exercise feedback. You can even measure your heart rate using the built-in handgrip heart rate monitor.

The console also features a selection of preset workouts designed to help you to burn calories and enhance your cardiovascular system. Each workout controls the speed and incline of the treadmill as it guides you through an effective exercise session.

You can even listen to your favorite workout music or audio books with the console's sound system while you exercise.

To turn on the power, see page 16. **To use the manual mode**, see page 16. **To use a preset workout**, see page 18. **To use the information mode**, see page 19. **To use the sound system**, see page 19.

IMPORTANT: If there is a sheet of plastic on the face of the console, remove the plastic. To prevent damage to the walking platform, wear clean athletic shoes while using the treadmill. The first time the treadmill is used, observe the alignment of the walking belt, and center the walking belt if necessary (see page 22).

Note: The console can display speed and distance in either miles or kilometers. To find which unit of measurement is selected, see THE INFORMATION MODE on page 19. For simplicity, all instructions in this section refer to miles.

HOW TO TURN ON THE POWER

IMPORTANT: If the treadmill has been exposed to cold temperatures, allow it to warm to room temperature before you turn on the power. If you do not do this, you may damage the console displays or other electrical components.

Plug in the power cord (see page 14). Next, locate the power switch on the treadmill frame near the power cord. Make sure that the switch is in the reset position.

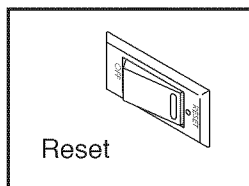

IMPORTANT: The console features a display demo mode, designed to be used if the treadmill is displayed in a store. If the displays light as soon as you plug in the power cord and press the power switch into the reset position, the demo mode is turned on. To turn off the demo mode, hold down the Stop button for a few seconds. If the displays remain lit, see THE INFORMATION MODE on page 19 to turn off the demo mode.

Next, stand on the foot rails of the treadmill. Find the clip attached to the key (see the drawing to the right) and slide the clip onto the waistband of your clothes. Then, insert the key into the console. After a moment, the displays will light. **IMPORTANT:** In an emergency, the key can be pulled from the console, causing the walking belt to slow to a stop. Test the clip by carefully taking a few steps backward; if the key is not pulled from the console, adjust the position of the clip.

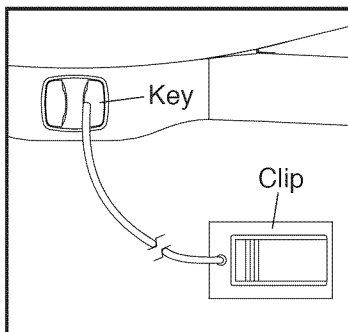

HOW TO USE THE MANUAL MODE

1. Insert the key into the console.

See HOW TO TURN ON THE POWER at the left.

2. Select the manual mode.

When the key is inserted, the manual mode will be selected. If you have selected a workout, remove the key from the console, and then reinsert it. Only zeros should appear in the displays.



3. Start the walking belt.

To start the walking belt, press the Start button, the Speed increase button, or one of the ten numbered Quick MPH buttons.

If you press the Start button or the Speed increase button, the walking belt will begin to move at 1 mph. As you exercise, change the speed of the walking belt as desired by pressing the Speed increase and decrease buttons. Each time you press one of the buttons, the speed setting will change by 0.1 mph; if you hold down the button, the speed setting will change in increments of 0.5 mph.

If you press one of the numbered Quick MPH buttons, the walking belt will gradually change speed until it reaches the selected speed setting.

To stop the walking belt, press the Stop button. The time will begin to flash in the display. To restart the walking belt, press the Start button, the Speed increase button, or one of the ten numbered Quick MPH buttons.

4. Change the incline of the treadmill as desired.

To change the incline of the treadmill, press the Incline increase and decrease buttons or one of the numbered Quick % Grade buttons. Each time you press the Incline increase or decrease button, the incline setting will change by 0.5 percent. If you press one of the numbered Quick % Grade buttons, the incline will gradually change until it reaches the selected incline setting.

5. Follow your progress with the displays.

When you select the manual mode, a track representing 1/4 mile (400 m) will appear in the matrix. As you walk or run on the treadmill, the indicators around the track will appear in succession until the entire track appears. The track will then disappear and the indicators will again begin to appear in succession.

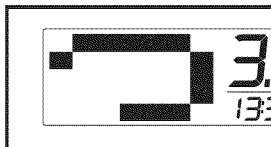

The lower left display can show the elapsed time and the distance that you have walked or run during your workout. Each time you change the incline, the display will show the incline setting for a few seconds. Note: When a workout is selected, the display will show the time remaining in the workout instead of the elapsed time.



The lower right display can show the speed of the walking belt and the approximate number of calories that you have burned during your workout. The display will also show your heart rate when you use the handgrip heart rate monitor (see step 6).

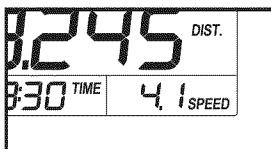

The upper display can show the elapsed time, the distance that you have walked or run, the approximate number of calories you have



burned, or the speed of the walking belt. Press the Priority Display button repeatedly until the upper display shows the information that you are most interested in viewing. Note: While information is shown in the upper display, the same information will not be shown in the lower left or lower right display.

To reset the displays, press the Stop button, remove the key, and then reinsert the key.

6. Measure your heart rate if desired.

Before using the handgrip heart rate monitor, remove the sheets of plastic from the metal contacts. In addition, make sure that your hands are clean.

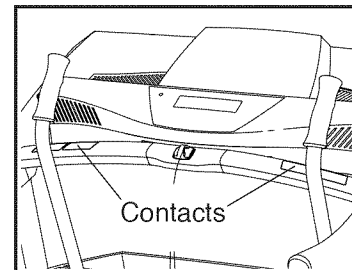

To measure your heart rate, **stand on the foot rails** and place your hands on the metal contacts—**avoid moving your hands**. When your pulse is detected, your heart rate will be shown. **For the most accurate heart rate reading, continue to hold the contacts for about 15 seconds.**

7. When you are finished exercising, remove the key from the console.

Step onto the foot rails, press the Stop button, and **adjust the incline of the treadmill to zero**. **The incline must be at zero when you fold the treadmill to the storage position, or you may damage the treadmill.** Next, remove the key from the console and put it in a secure place.

When you are finished using the treadmill, press the power switch into the off position and unplug the power cord. **IMPORTANT: If you do not do this, the treadmill's electrical components may wear prematurely.**

HOW TO USE A PRESET WORKOUT

1. Insert the key into the console.

See HOW TO TURN ON THE POWER on page 16.

2. Select a preset workout.

To select a preset workout, press the Weight Loss Workouts button or the Cross Train button repeatedly until the desired workout appears in the display.

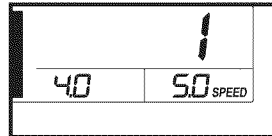

When you select a workout, the maximum speed and incline settings of the workout will flash in the displays for a few seconds; then the display will show how long the workout will last. A profile of the speed settings of the workout will scroll across the matrix.

3. Start the walking belt.

Press the Start button or the Speed increase button to start the workout. A moment after you press the button, the treadmill will automatically adjust to the first speed and incline settings for the workout. Hold the handrails and begin walking.

Each workout is divided into 30 one-minute segments. One speed setting and one incline setting are programmed for each segment. Note: The same speed and incline settings may be programmed for consecutive segments.

During the workout, the profile will show your progress. The flashing segment of the profile represents the current segment of the workout. The height of the flashing segment indicates the speed setting for the current segment. At the end of each segment, a series of tones will sound

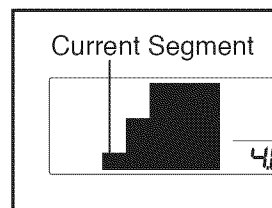

and the next segment of the profile will begin to flash. If a different speed and/or incline setting is programmed for the next segment, the speed and/or incline setting will flash in the display to alert you. The treadmill will then automatically adjust to the speed and incline settings for the next segment.

The workout will continue in this way until the last segment of the profile flashes in the display and the last segment ends. The walking belt will then slow to a stop.

If the speed or incline setting for the current segment is too high or too low, you can manually override the setting by pressing the Speed and Incline buttons; **however, when the current segment of the workout ends, the treadmill will automatically adjust to the speed and incline settings for the next segment.**

To stop the workout at any time, press the Stop button. To restart the workout, press the Start button or the Speed increase button. The walking belt will begin to move at 1 mph. When the next segment of the workout begins, the treadmill will automatically adjust to the speed and incline settings for that segment.

4. Follow your progress with the displays.

See step 5 on page 17.

5. Measure your heart rate if desired.

See step 6 on page 17.

6. When you are finished exercising, remove the key from the console.

See step 7 on page 17.

THE INFORMATION MODE

The console features an information mode that keeps track of treadmill usage information and allows you to select a unit of measurement for the console. You can also turn on and turn off the display demo mode.

To select the information mode, insert the key into the console while holding down the Stop button. Then, release the Stop button. When the information mode is selected, the following information will be shown:

The upper display will show the total number of hours that the treadmill has been used.



The lower left display will show the total number of miles or kilometers that the walking belt has moved.

An “E” for English miles or an “M” for metric kilometers will appear in the lower right display. Press the Speed increase button to change the unit of measurement, if desired.

The console features a display demo mode, designed to be used if the treadmill is displayed in a store. While the demo mode is turned on, the console will function normally when you plug in the power cord, press the power switch into the reset position, and insert the key into the console. However, when you remove the key, the displays will remain lit, although the buttons will not function. If the demo mode is turned on, a “d” will appear in the lower right display while the information mode is selected. To turn on or turn off the demo mode, press the Speed decrease button.

To exit the information mode, remove the key from the console.

HOW TO USE THE SOUND SYSTEM

To play music or audio books through the console sound system while you exercise, plug a 3.5 mm male to 3.5 mm male audio cable (not included) into the jack on the console and into a jack on your MP3 player, CD player, or other personal audio player; **make sure that the audio cable is fully plugged in. Note: To purchase an audio cable, see your local electronics store.**

Next, press the play button on your personal audio player. Adjust the volume level using the volume control on your personal audio player.

If you are using a personal CD player and the CD skips, set the CD player on the floor or another flat surface instead of on the console.

HOW TO USE THE UPPER BODY ARMS

As you walk on the treadmill, you can hold the handrails or use the upper body arms. To exercise your arms, shoulders, and back for a total body workout, move the upper body arms forward and backward as you walk on the treadmill.

To vary the intensity of your upper body exercise, the resistance of the upper body arms can be adjusted. **To increase the resistance**, turn the resistance knobs clockwise; **to decrease the resistance**, turn the knobs counterclockwise.

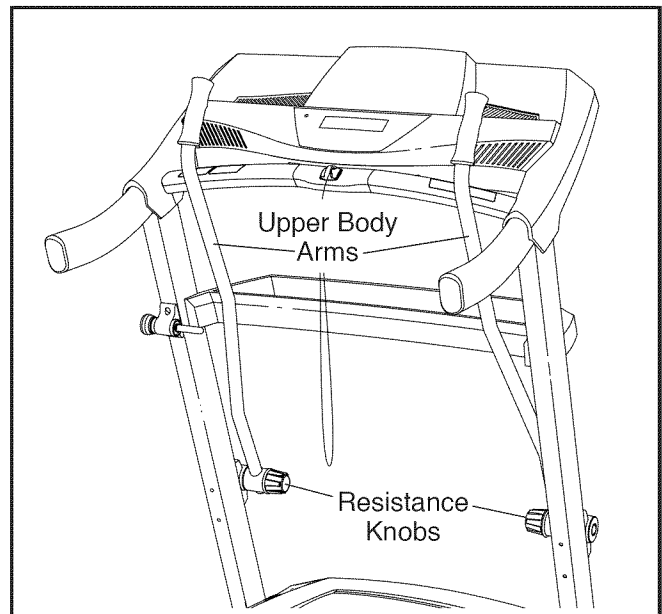

HOW TO FOLD AND MOVE THE TREADMILL

HOW TO FOLD THE TREADMILL

Before folding the treadmill, adjust the incline to zero. If you do not do this, you may damage the treadmill when you fold it. Remove the key and unplug the power cord. **CAUTION:** You must be able to safely lift 45 lbs. (20 kg) to raise, lower, or move the treadmill.

1. Hold the metal frame firmly in the location shown by the arrow below. **CAUTION: Do not hold the frame by the plastic foot rails. Bend your legs and keep your back straight.**

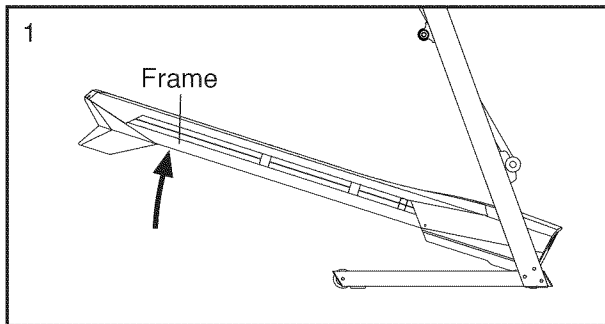

2. Hold the frame firmly with your right hand. Pull the latch knob to the left and hold it. Raise the frame until the hole in the platform cushion is aligned with the latch pin. Then, slowly release the latch knob; **make sure that the latch pin is fully inserted into the platform cushion.**

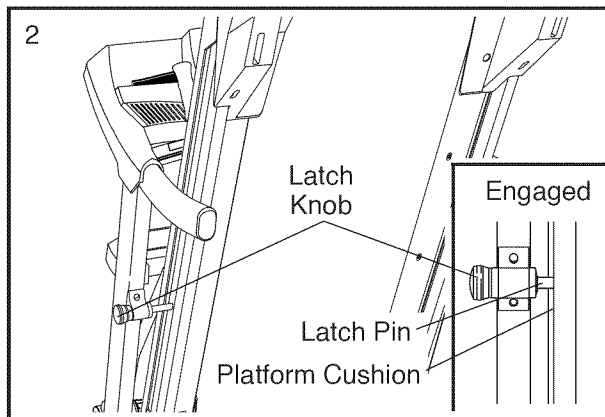

To protect the floor or carpet, place a mat under the treadmill. Keep the treadmill out of direct sunlight. Do not leave the treadmill in the storage position in temperatures above 85° F (30° C).

HOW TO MOVE THE TREADMILL

Before moving the treadmill, fold it as described at the left. **CAUTION: Make sure that the latch pin is fully inserted into the platform cushion. Moving the treadmill may require two people.**

1. Hold the frame and one of the handrails, and place one foot against a wheel.

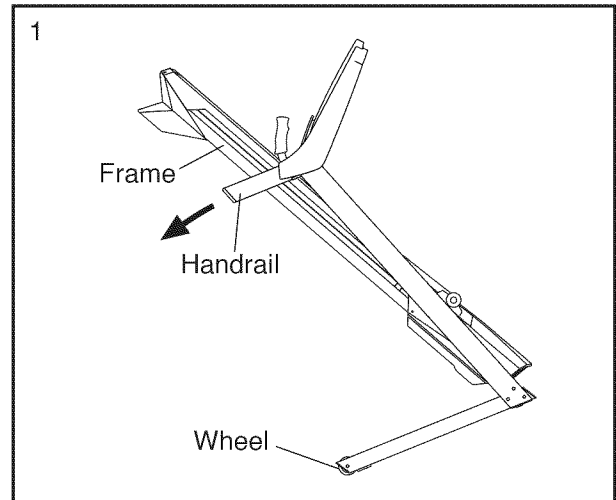

2. Pull back on the handrail until the treadmill will roll on the wheels, and carefully move it to the desired location. **CAUTION: Do not move the treadmill without tipping it back, do not pull on the frame, and do not move the treadmill over an uneven surface.**
3. Place one foot against a wheel, and carefully lower the treadmill.

HOW TO LOWER THE TREADMILL FOR USE

1. **See drawing 2.** Hold the upper end of the treadmill with your right hand. Pull the latch knob to the left and hold it. Next, lower the frame until it is past the latch pin. Make sure that the pin does not hit against the foot rail. Then, release the latch knob.
2. **See drawing 1 at the left.** Hold the metal frame firmly with both hands, and lower it to the floor. **CAUTION: Do not hold the frame by the plastic foot rails, and do not drop the frame. Bend your legs and keep your back straight.**

TROUBLESHOOTING

Most treadmill problems can be solved by following the simple steps below. Find the symptom that applies, and follow the steps listed. If further assistance is needed, see the back cover of this manual.

SYMPTOM: The power does not turn on

- Make sure that the power cord is plugged into a surge suppressor and that the surge suppressor is plugged into a properly grounded outlet (see page 14). Use only a surge suppressor that meets all of the specifications described on page 14.
IMPORTANT: The treadmill is not compatible with GFCI-equipped outlets and may not be compatible with AFCI-equipped outlets.
- After the power cord has been plugged in, make sure that the key is inserted into the console.
- Check the power switch located on the treadmill frame near the power cord. If the switch protrudes as shown, the switch has tripped. To reset the power switch, wait for five minutes and then press the switch back in.

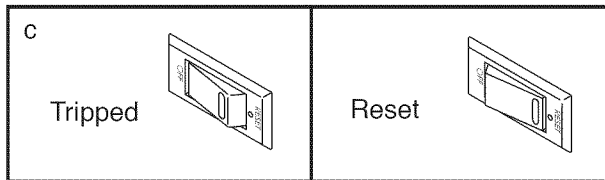

SYMPTOM: The power turns off during use

- Check the power switch (see the drawing above). If the switch has tripped, wait for five minutes and then press the switch back in.
- Make sure that the power cord is plugged in. If the power cord is plugged in, unplug it, wait for five minutes, and then plug it back in.
- Remove the key from the console, and then reinsert it.
- If the treadmill still will not run, please see the back cover of this manual.

SYMPTOM: The console displays remain lit when you remove the key from the console

- The console features a display demo mode, designed to be used if the treadmill is displayed in a store. If the displays remain lit when you remove

the key, the demo mode is turned on. To turn off the demo mode, hold down the Stop button for a few seconds. If the displays are still lit, see THE INFORMATION MODE on page 19 to turn off the demo mode.

SYMPTOM: The incline of the treadmill does not change correctly

- Hold down the Stop button and the Speed increase button, insert the key into the console, and then release the Stop button and the Speed increase button. Next, press the Stop button and then press the Incline increase or decrease button. The treadmill will automatically rise to the maximum incline level and then return to the minimum level. This will recalibrate the incline system. If the incline system does not begin calibrating, press the Stop button again, and then press the Incline increase or decrease button again. When the incline system is calibrated, remove the key from the console.

SYMPTOM: The upper body arms squeak during use

- (Note: Correcting this problem requires a small amount of marine grease, available at hardware stores.) Turn the resistance knob (A) counterclockwise and remove it. Next, remove the resistance cone (B) and the upper body arm (C), along with the resistance plate (D), plastic spacer (E), spring washer (F), washers (G), and thrust bearing (H). (Note: If the resistance plate comes out of the resistance cone, press it back in.) Apply a thin layer of white marine grease to the outer surface of the resistance cone. Then reattach all parts in the order shown below.

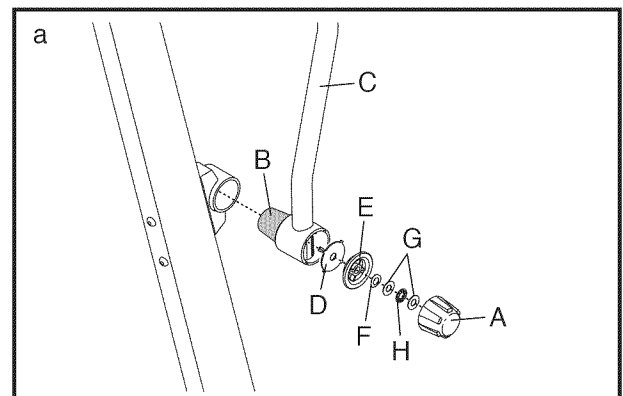

SYMPTOM: The walking belt slows when walked on

- a. Use only a surge suppressor that meets all of the specifications described on page 14.
- b. If the walking belt is overtightened, treadmill performance may decrease and the walking belt may become damaged. Remove the key and **UNPLUG THE POWER CORD**. Using the hex key, turn both idler roller screws counterclockwise, 1/4 of a turn. When the walking belt is properly tightened, you should be able to lift each edge of the walking belt 2 to 3 in. (5 to 7 cm) off the walking platform. Be careful to keep the walking belt centered. Then, plug in the power cord, insert the key, and run the treadmill for a few minutes. Repeat until the walking belt is properly tightened.

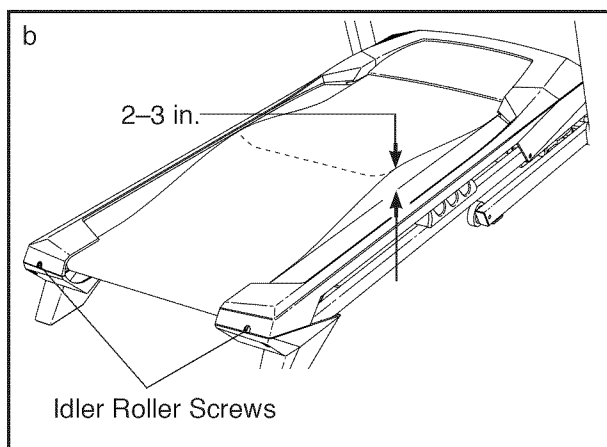

- c. Your treadmill features a walking belt coated with high-performance lubricant. **IMPORTANT: Never apply silicone spray or other substances to the walking belt or the walking platform unless instructed to do so by an authorized service representative. Such substances may deteriorate the walking belt and cause excessive wear.** If you suspect that the walking belt needs more lubricant, see the back cover of this manual.
- d. If the walking belt still slows when walked on, see the back cover of this manual.

SYMPTOM: The walking belt is off-center or slips when walked on

- a. **If the walking belt is off-center**, first remove the key and **UNPLUG THE POWER CORD**. **If the walking belt has shifted to the left**, use the hex key to turn the left idler roller screw clockwise 1/2 of a turn; **if the walking belt has shifted to the right**, turn the left idler roller screw counterclockwise 1/2 of a turn. Be careful not to overtighten the walking belt. Then, plug in the power cord, insert the key, and run the treadmill for a few minutes. Repeat until the walking belt is centered.

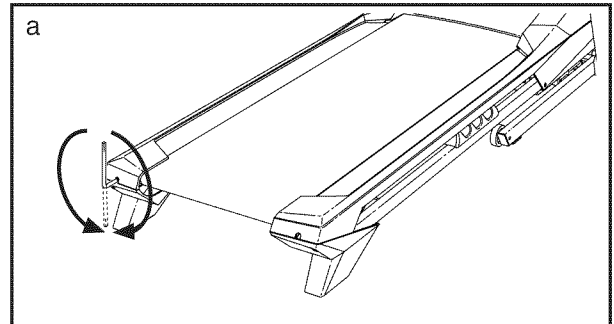

- b. **If the walking belt slips when walked on**, first remove the key and **UNPLUG THE POWER CORD**. Using the hex key, turn both idler roller screws clockwise, 1/4 of a turn. When the walking belt is correctly tightened, you should be able to lift each edge of the walking belt 2 to 3 in. (5 to 7 cm) off the walking platform. Be careful to keep the walking belt centered. Then, plug in the power cord, insert the key, and carefully walk on the treadmill for a few minutes. Repeat until the walking belt is properly tightened.

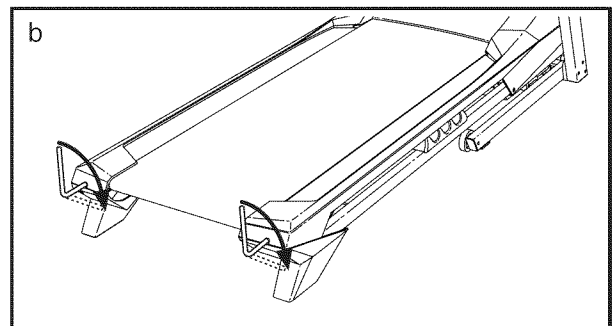

EXERCISE GUIDELINES

⚠️ WARNING: Before beginning this or any exercise program, consult your physician. This is especially important for persons over age 35 or persons with pre-existing health problems.

The heart rate monitor is not a medical device. Various factors may affect the accuracy of heart rate readings. The heart rate monitor is intended only as an exercise aid in determining heart rate trends in general.

These guidelines will help you to plan your exercise program. For detailed exercise information, obtain a reputable book or consult your physician. Remember, proper nutrition and adequate rest are essential for successful results.

EXERCISE INTENSITY

Whether your goal is to burn fat or to strengthen your cardiovascular system, exercising at the proper intensity is the key to achieving results. You can use your heart rate as a guide to find the proper intensity level. The chart below shows recommended heart rates for fat burning and aerobic exercise.

165	155	145	140	130	125	115	♥♥
145	138	130	125	118	110	103	♥
125	120	115	110	105	95	90	♥
20	30	40	50	60	70	80	

To find the proper intensity level, find your age at the bottom of the chart (ages are rounded off to the nearest ten years). The three numbers listed above your age define your “training zone.” The lowest number is the heart rate for fat burning, the middle number is the heart rate for maximum fat burning, and the highest number is the heart rate for aerobic exercise.

Burning Fat—To burn fat effectively, you must exercise at a low intensity level for a sustained period of time. During the first few minutes of exercise, your body uses carbohydrate calories for energy. Only after the first few minutes of exercise does your body begin to use stored fat calories for energy. If your goal is to burn fat, adjust the intensity of your exercise until your heart rate is near the lowest number in your training zone. For maximum fat burning, exercise with your heart rate near the middle number in your training zone.

Aerobic Exercise—If your goal is to strengthen your cardiovascular system, you must perform aerobic exercise, which is activity that requires large amounts of oxygen for prolonged periods of time. For aerobic exercise, adjust the intensity of your exercise until your heart rate is near the highest number in your training zone.

WORKOUT GUIDELINES

Warming Up—Start with 5 to 10 minutes of stretching and light exercise. A warm-up increases your body temperature, heart rate, and circulation in preparation for exercise.

Training Zone Exercise—Exercise for 20 to 30 minutes with your heart rate in your training zone. (During the first few weeks of your exercise program, do not keep your heart rate in your training zone for longer than 20 minutes.) Breathe regularly and deeply as you exercise; never hold your breath.

Cooling Down—Finish with 5 to 10 minutes of stretching. Stretching increases the flexibility of your muscles and helps to prevent post-exercise problems.

EXERCISE FREQUENCY

To maintain or improve your condition, complete three workouts each week, with at least one day of rest between workouts. After a few months of regular exercise, you may complete up to five workouts each week, if desired. Remember, the key to success is to make exercise a regular and enjoyable part of your everyday life.

SUGGESTED STRETCHES

The correct form for several basic stretches is shown at the right. Move slowly as you stretch—never bounce.

1. Toe Touch Stretch

Stand with your knees bent slightly and slowly bend forward from your hips. Allow your back and shoulders to relax as you reach down toward your toes as far as possible. Hold for 15 counts, then relax. Repeat 3 times. Stretches: Hamstrings, back of knees and back.

2. Hamstring Stretch

Sit with one leg extended. Bring the sole of the opposite foot toward you and rest it against the inner thigh of your extended leg. Reach toward your toes as far as possible. Hold for 15 counts, then relax. Repeat 3 times for each leg. Stretches: Hamstrings, lower back and groin.

3. Calf/Achilles Stretch

With one leg in front of the other, reach forward and place your hands against a wall. Keep your back leg straight and your back foot flat on the floor. Bend your front leg, lean forward and move your hips toward the wall. Hold for 15 counts, then relax. Repeat 3 times for each leg. To cause further stretching of the achilles tendons, bend your back leg as well. Stretches: Calves, achilles tendons and ankles.

4. Quadriceps Stretch

With one hand against a wall for balance, reach back and grasp one foot with your other hand. Bring your heel as close to your buttocks as possible. Hold for 15 counts, then relax. Repeat 3 times for each leg. Stretches: Quadriceps and hip muscles.

5. Inner Thigh Stretch

Sit with the soles of your feet together and your knees outward. Pull your feet toward your groin area as far as possible. Hold for 15 counts, then relax. Repeat 3 times. Stretches: Quadriceps and hip muscles.

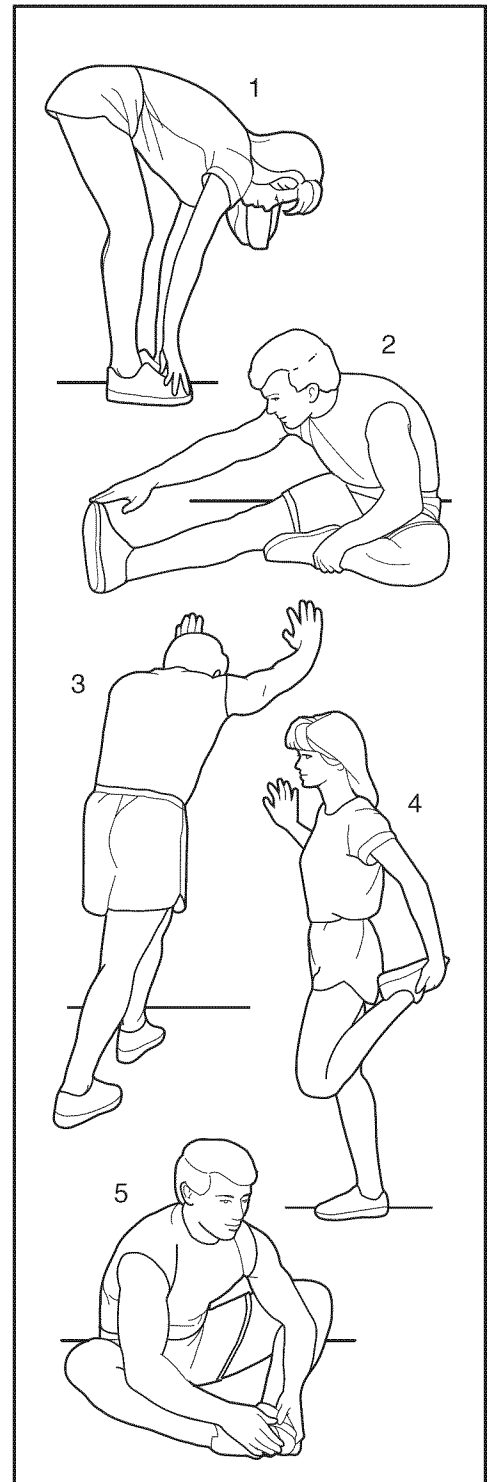

NOTES

NOTES

PART LIST

Model No. 831.24853.1 R1213A

Key No.	Qty.	Description	Key No.	Qty.	Description
1	8	#8 x 1/2" Ground Screw	45	1	Drive Motor Belt
2	6	3/8" x 3 1/4" Screw	46	1	Right Rear Foot
3	10	3/8" Star Washer	47	8	#10 Flat Washer
4	43	#8 x 3/4" Screw	48	1	Motor Hood
5	4	1/4" x 1" Screw	49	1	Incline Motor
6	4	5/16" Star Washer	50	2	Lift Frame Bushing
7	1	Console Frame	51	1	Lift Frame
8	2	#10 x 3/4" Screw	52	1	Belly Pan
9	2	3/8" x 2 1/2" Bolt	53	1	Power Cord Grommet
10	4	3/8" Nut	54	1	Power Cord
11	2	M6 x 55mm Screw	55	1	Power Switch
12	2	3/8" x 1" Bolt	56	2	#10 x 3/4" Insert Screw
13	3	Hood Clip	57	1	Console
14	6	#8 x 3/4" Truss Head Screw	58	1	Console Base
15	1	3/8" x 1 3/4" Bolt	59	1	Left Handrail
16	2	3/8" Jam Nut	60	2	Handrail Cap
17	2	1/4" x 3/8" Screw	61	8	1/4" External Star Washer
18	4	#8 x 1/2" Screw	62	1	Key/Clip
19	4	5/16" x 1 1/2" Bolt	63	1	Upright Wire
20	4	5/16" Nut	64	1	Right Handrail
21	2	#8 x 1/2" Pan Head Screw	65	2	Lift Frame Pin
22	2	#8 Star Washer	66	1	Left Upright
23	8	#8 x 5/8" Screw	67	1	Latch Housing
24	2	Drive Roller Washer	68	1	Latch Pin Assembly
25	2	1/4" x 1 1/4" Screw	69	2	Warning Decal
26	2	Incline Frame Washer	70	4	Base Cap
27	1	Left Foot Rail	71	2	Thick Base Pad
28	4	Platform Cushion	72	2	Thin Base Pad
29	1	Caution Decal	73	2	Upright Grommet
30	2	Belt Guide	74	1	Base
31	1	Drive Roller/Pulley	75	2	Wheel
32	1	3/8" x 1 1/2" Bolt	76	1	Right Upright
33	4	1/4" x 3 1/2" Screw	77	4	1/4" x 1 1/4" Screw
34	12	#8 x 3/4" Tek Screw	78	4	5/16" x 3 1/5" Screw
35	1	Drive Motor	79	1	Console Ground Wire
36	1	Controller	80	1	M4.2 x 8mm Screw
37	1	Controller Plate	81	1	Left Upper Body Arm
38	1	Frame	82	1	Right Upper Body Arm
39	1	Walking Platform	83	1	Left Tray Bracket
40	1	Walking Belt	84	1	Right Tray Bracket
41	1	Right Foot Rail	85	2	Upper Body Arm Insert
42	1	Idler Roller	86	1	Tray
43	1	Left Rear Foot	87	2	1/4" Star Washer
44	4	Wire Tie	*	-	User's Manual

Note: Specifications are subject to change without notice. For information about ordering replacement parts, see the back cover of this manual. **If a part is missing, call 1-888-533-1333.** *These parts are not illustrated.

EXPLODED DRAWING A

Model No. 831.24853.1 R1213A

28

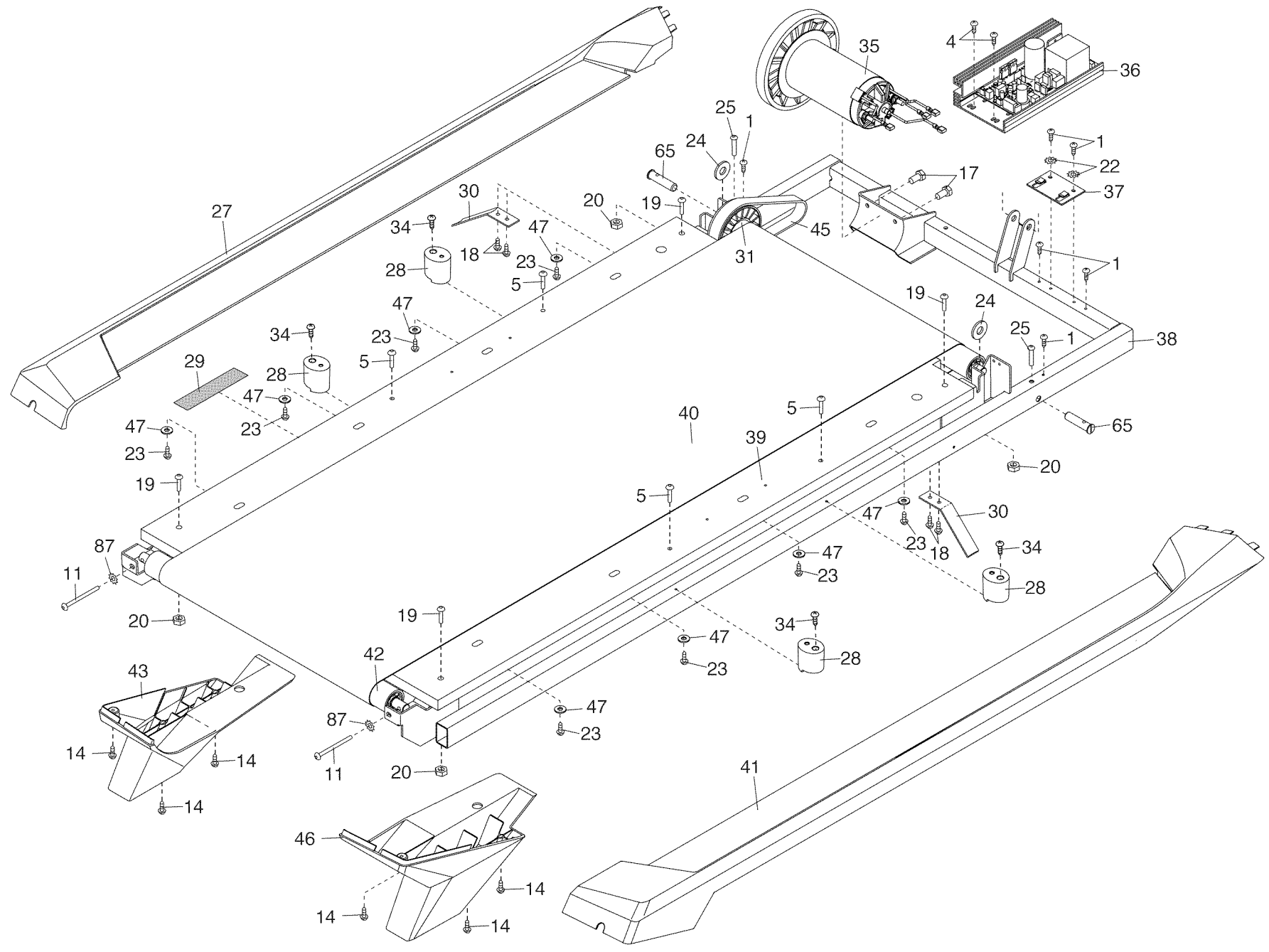

EXPLODED DRAWING B

Model No. 831.24853.1 R1213A

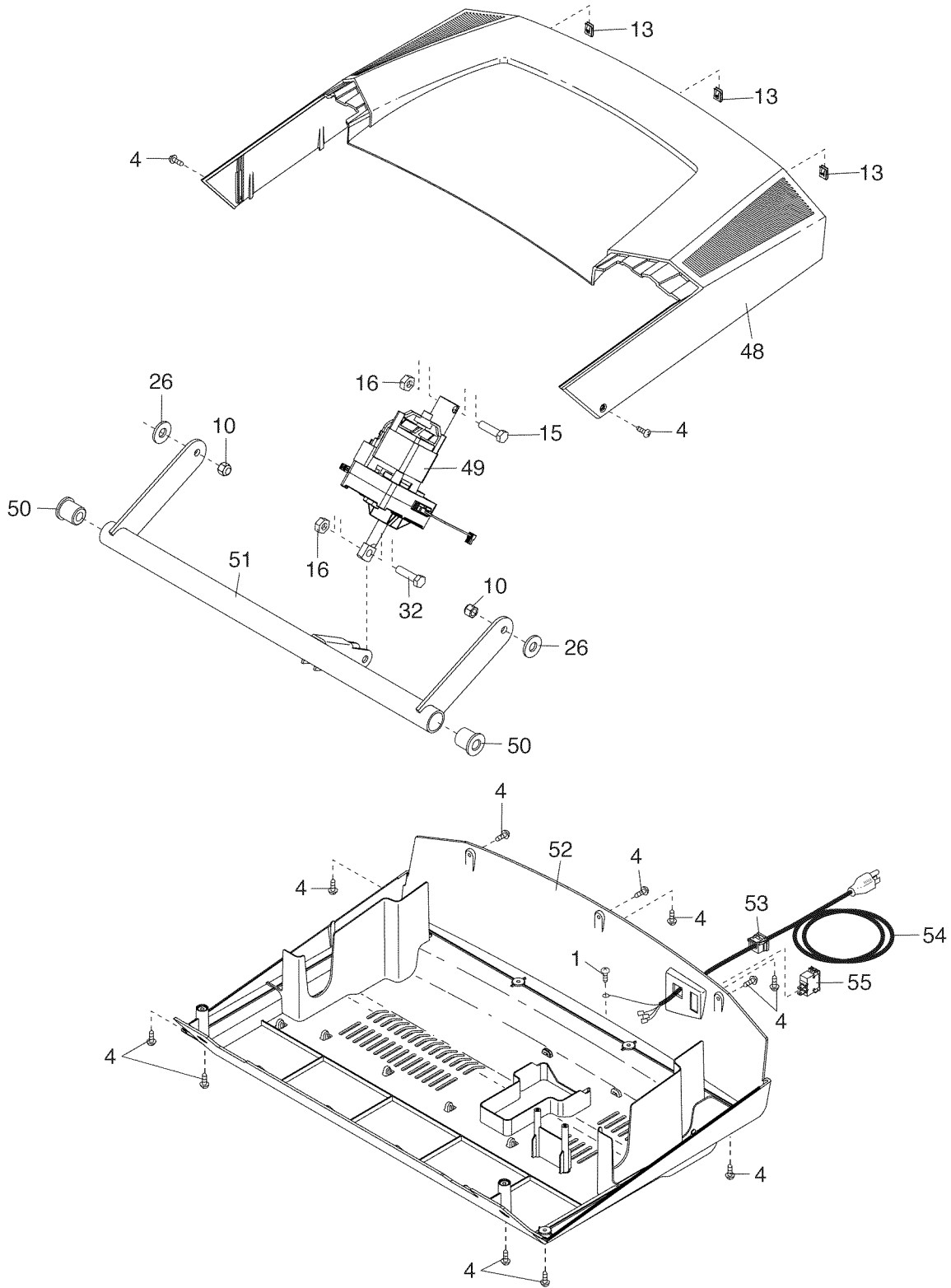

EXPLODED DRAWING C

Model No. 831.24853.1 R1213A

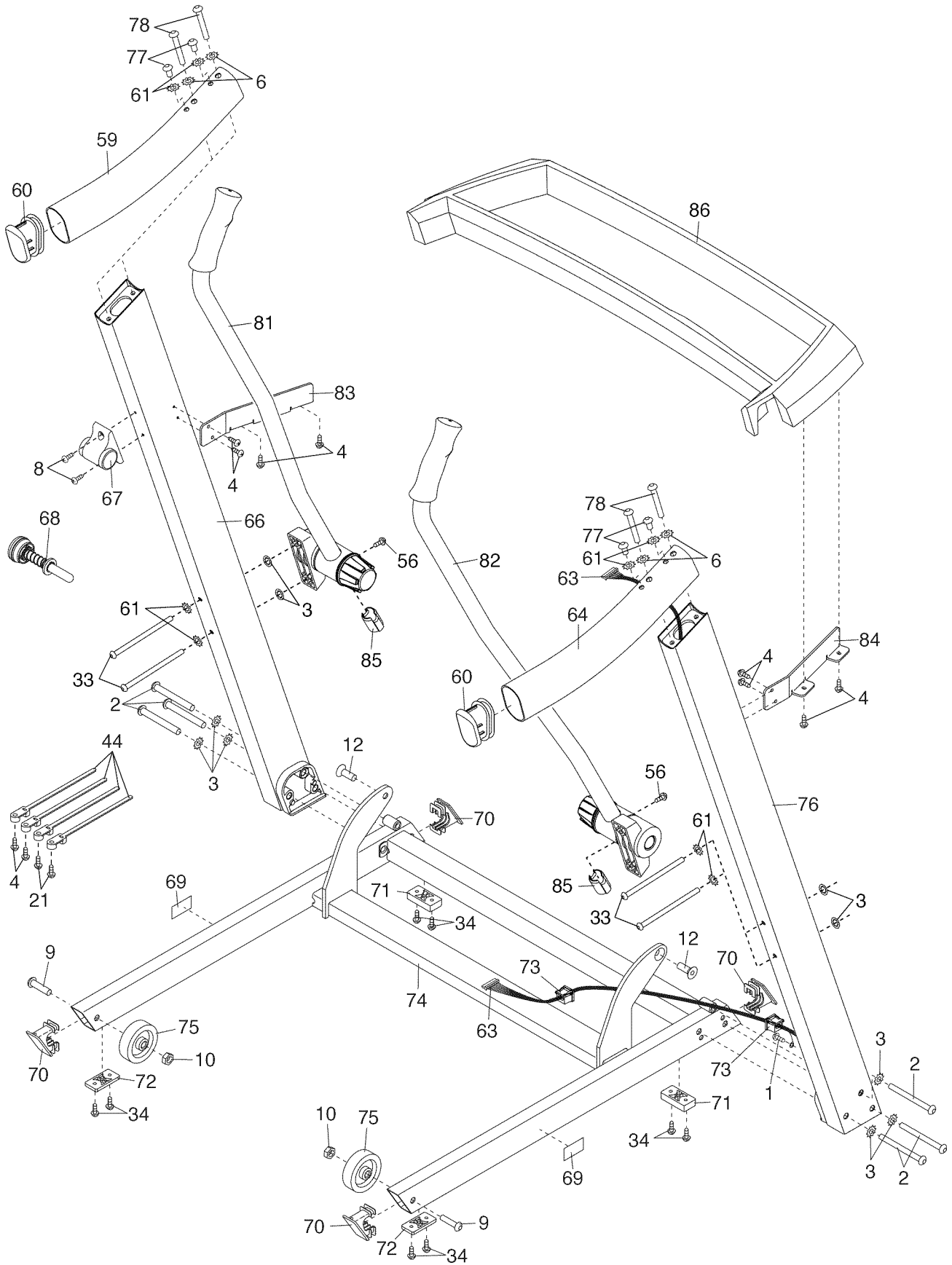

EXPLODED DRAWING D

Model No. 831.24853.1 R1213A

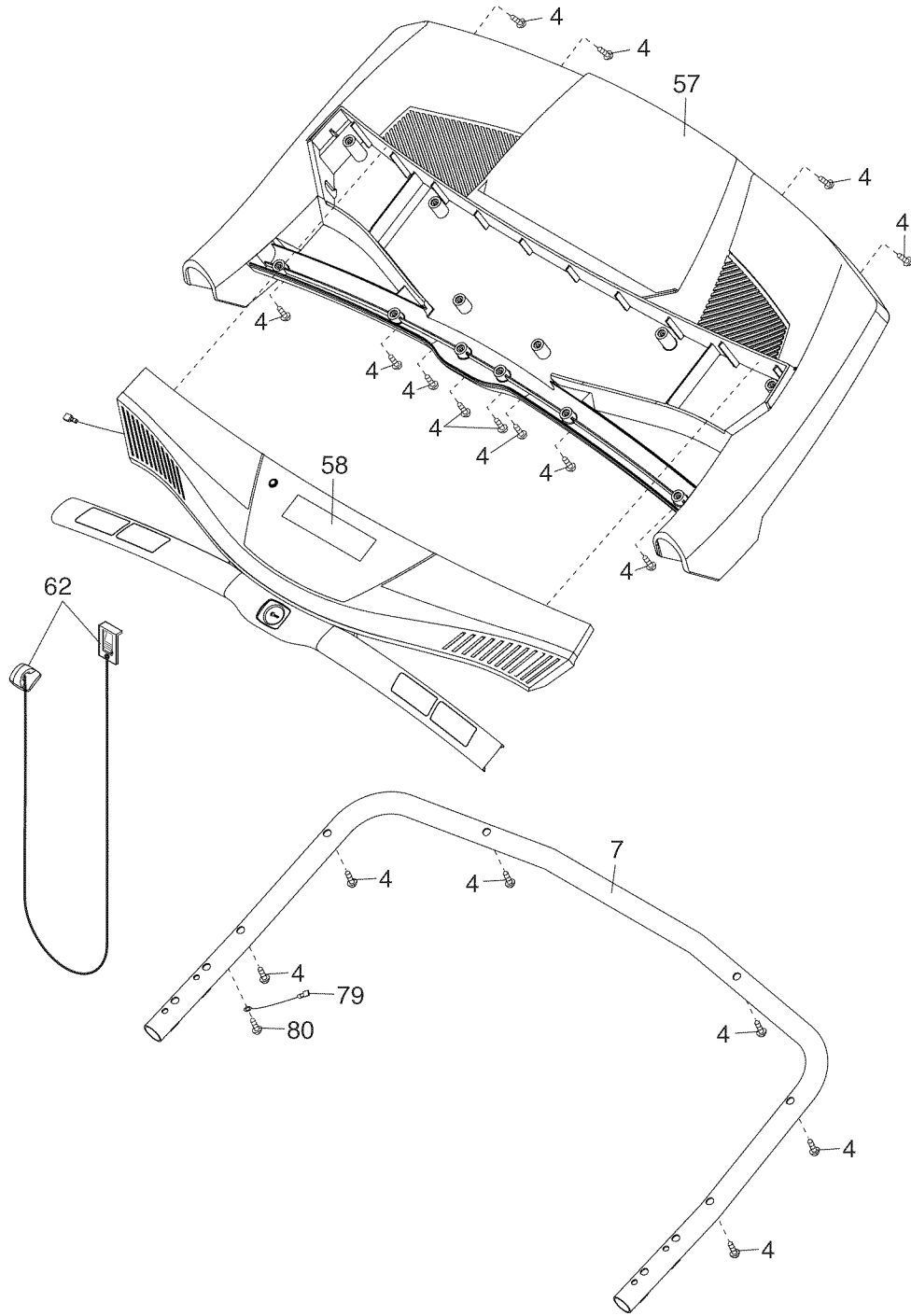

Get it fixed, at your home or ours!

Your Home

For repair—**in your home**—of **all** major brand appliances, lawn and garden equipment, or heating and cooling systems, **no matter who made it, no matter who sold it!**

For the replacement parts, accessories, and user's manuals that you need to do-it-yourself.

For Sears professional installation of home appliances and items like garage door openers and water heaters.

1-800-4-MY-HOME® (1-800-469-4663)

Call anytime, day or night (U.S.A. and Canada)

www.sears.com

www.sears.ca

Our Home

For repair of carry-in items like vacuums, lawn equipment, and electronics, call or go on-line for the location of your nearest **Sears Parts & Repair Center.**

1-800-488-1222 Call anytime, day or night (U.S.A. only)

www.sears.com

To purchase a protection agreement (U.S.A.) or maintenance agreement (Canada) on a product serviced by Sears:

1-800-827-6655 (U.S.A.)

1-800-361-6665 (Canada)

Para pedir servicio de reparación a domicilio, y para ordenar piezas:

1-888-SU-HOGAR® (1-888-784-6427)



® Registered Trademark / ™ Trademark / ™ Service Mark of Sears Brands, LLC
® Marca Registrada / ™ Marca de Fábrica / ™ Marca de Servicio de Sears Brands, LLC

90-DAY FULL WARRANTY

If this Sears Treadmill Exerciser fails due to a defect in material or workmanship within 90 days of the date of purchase, call 1-800-4-MY-HOME® (1-800-469-4663) to arrange for free repair (or replacement if repair proves impossible). The frame and drive motor are warranted for five (5) years from the date of purchase.

This warranty does not apply when the Treadmill Exerciser is used commercially or for rental purposes.

This warranty gives you specific legal rights, and you may also have other rights which vary from state to state.

Sears, Roebuck and Co., Hoffman Estates, IL 60179