

For product support, visit

www.hd.philips.com

HTL5120



User manual

EN: For further assistance, call the customer support service in your country.

- To obtain assistance in the U.S.A., Canada, Puerto Rico, or the U.S. Virgin Islands, contact Philips Customer Care Center at 1-866-310-0744
- To obtain assistance in Mexico, contact Philips Customer Care Center at 01 800 839 1989; Mexico City: 58 87 97 36

For Product recycling information, please visit - www.recycle.philips.com

P&F USA, Inc.

PHILIPS

Contents

1 Important	2
Important safety instructions	2
Care for your product	3
Care of the environment	3
Help and support	4

2 Your SoundBar	5
Main unit	5
Remote control	5
Connectors	7

3 Connect	8
Connect to TV	8
Connect digital devices through HDMI	8
Connect audio from TV and other devices	9

4 Use your SoundBar	10
Adjust the volume	10
Choose your sound	10
MP3 player	11
Play audio through Bluetooth	11
Auto standby	12
Apply factory settings	12

5 Wall mount your SoundBar	13
Wall mount	13

6 Product specifications	14
---------------------------------	----

7 Troubleshooting	15
--------------------------	----

8 Notice	16
Notice of compliance	16
Trademarks	16

1 Important



Read and understand all instructions before you use your product. If damage is caused by failure to follow instructions, the warranty does not apply.

Important safety instructions

- Read these instructions.
- Keep these instructions.
- Heed all warnings.
- Follow all instructions.
- Do not use this apparatus near water.
- Clean only with dry cloth.
- Do not block any ventilation openings. Install in accordance with the manufacturer's instructions.
- Do not install near any heat sources such as radiators, heat registers, stoves, or other apparatus (including amplifiers) that produce heat.



- Do not defeat the safety purpose of the polarized or grounding-type plug. A polarized plug has two blades with one wider than the other. A grounding type plug has two blades and a third grounding prong. The wide blade or the third prong are provided for your safety. If the provided plug does not fit into your outlet, consult an electrician for replacement of the obsolete outlet.
- Protect the power cord from being walked on or pinched, particularly at plugs, convenience receptacles, and the point where they exit from the apparatus.
- Only use attachments/accessories specified by the manufacturer.

- Use only with the cart, stand, tripod, bracket or table specified by the manufacturer or sold with the apparatus. When a cart is used, use caution when moving the cart/apparatus combination to avoid injury from tip-over.
- Unplug this apparatus during lightning storm or when unused for long periods of time.
- Refer all servicing to qualified service personnel. Servicing is required when the apparatus has been damaged in any way, such as power-supply cord or plug is damaged, liquid has been spilled or objects have fallen into the apparatus, the apparatus has been exposed to rain or moisture, does not operate normally, or has been dropped.
- Battery usage CAUTION - To prevent battery leakage which may result in bodily injury, property damage, or damage to the unit:
 - Install all batteries correctly, + and - as marked on the unit.
 - Do not mix batteries (old and new or carbon and alkaline, etc.).
 - Remove batteries when the unit is not used for a long time.
 - The batteries shall not be exposed to excessive heat such as sunshine, fire or the like.
 - Perchlorate Material - special handling may apply. See www.dts.com/hazardouswaste/perchlorate.
- The product/remote control may contain a coin/button type battery, which can be swallowed. Keep the battery out of reach of children at all times! If swallowed, the battery can cause serious injury or death. Severe internal burns can occur within two hours of ingestion.

- If you suspect that a battery has been swallowed or placed inside any part of the body, seek immediate medical attention.
- When you change the batteries, always keep all new and used batteries out of reach of children. Ensure that the battery compartment is completely secure after you replace the battery.
- If the battery compartment cannot be completely secured, discontinue use of the product. Keep out of reach of children and contact the manufacturer.
- **Apparatus shall not be exposed to dripping or splashing.**
- **Do not place any sources of danger on the apparatus** (for example, liquid filled objects, lighted candles).
- This apparatus may contain lead and mercury. Dispose according to local, State or Federal laws. For disposal or recycling information, please contact your local authorities. For additional assistance on recycling options, please contact www.mygreenelectronics.com or www.eiae.org or www.recycle.philips.com.
- Where the MAINS plug or an appliance coupler is used as the disconnect device, the disconnect device shall remain readily operable.
- Do not place this apparatus on the furniture that is capable of being tilted by a child and an adult leaning, pulling, standing or climbing on it. A falling apparatus can cause serious injury or even death.
- This apparatus should not be placed in a built-in installation such as a bookcase or rack unless proper ventilation is provided. Make sure to leave a space of 7.8 inches (20cm) or more around this apparatus.

Class II equipment symbol



This symbol indicates that the unit has a double insulation system.



This 'bolt of lightning' indicates uninsulated material within your unit may cause an electrical shock. For the safety of everyone in your household, please do not remove product covering.



The 'exclamation point' calls attention to features for which you should read the enclosed literature closely to prevent operating and maintenance problems.

WARNING: To reduce the risk of fire or electric shock, this apparatus should not be exposed to rain or moisture and objects filled with liquids, such as vases, should not be placed on this apparatus.

CAUTION: To prevent electric shock, match wide blade of plug to wide slot, fully insert.

Care for your product

Use only microfiber cloth to clean the product.

Care of the environment



Your product is designed and manufactured with high quality materials and components, which can be recycled and reused. Please visit www.recycle.philips.com for additional information on a recycling center in your area.

Never dispose of your product with other household waste. Please inform yourself about the local rules on the separate collection of

electrical and electronic products and batteries. The correct disposal of these products helps prevent potentially negative consequences on the environment and human health.

The batteries supplied do not contain the heavy metals mercury and cadmium. Nevertheless, in many areas batteries may not be disposed of with your household waste. Please ensure you dispose of batteries according to local regulations.

For perchlorate material, special handling may apply. Visit www.dtsc.ca.gov/hazardouswaste/perchlorate.

Help and support

Philips provides extensive online support. Visit our website at www.philips.com/support to:

- download the user manual and the quick start guide
- watch video tutorials (available only for selected models)
- find answers to frequently answered questions (FAQs)
- email us a question
- chat with our support representative.

Follow the instructions on the website to select your language, and then enter your product model number.

Alternatively, you can contact Philips Consumer Care in your country. Before you contact Philips, note down the model number and serial number of your product. You can find this information on the back or bottom of your product.

2 Your SoundBar

Congratulations on your purchase, and welcome to Philips! To fully benefit from the support that Philips offers, register your SoundBar at www.philips.com/welcome.

Main unit

This section includes an overview of the main unit.

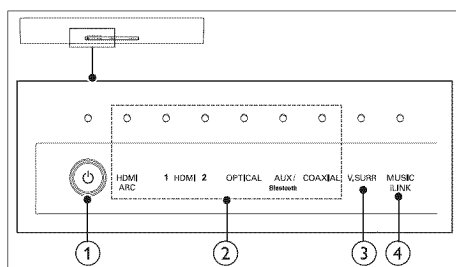

- ① **⏻ (Standby-On/Standby indicator)**
 - Switch the SoundBar on or to standby.
 - When the SoundBar is in standby, the standby indicator turns red.
- ② **Volume indicator/Source indicators**

When you change volume, volume indicators light up to indicate the volume level.

Source indicator lights up when a source is selected.

 - **HDMI ARC:** Lights up when you select HDMI ARC as the input source.
 - **HDMI 1:** Lights up when you select HDMI IN 1 as the input source. Blinks for five seconds when you play Dolby audio.
 - **HDMI 2:** Lights up when you select HDMI IN 2 as the input source. Blinks for five seconds when you play DTS audio.

- **OPTICAL:** Lights up when you switch to optical input source.
- **AUX/Bluetooth:** Lights up when you switch to analog input source. Blinks when you switch to Bluetooth mode.
- **COAXIAL:** Lights up when you switch to coaxial input source.

- ③ **Volume indicator/V. SURR indicator**
 - When you change volume, volume indicators light up to indicate the volume level.
 - Lights up when you select Virtual Surround sound.
- ④ **Volume indicator/MUSIC iLINK indicator**
 - When you change volume, volume indicators light up to indicate the volume level.
 - Lights up when you select MUSIC iLINK as the input source.

Remote control

This section includes an overview of the remote control.

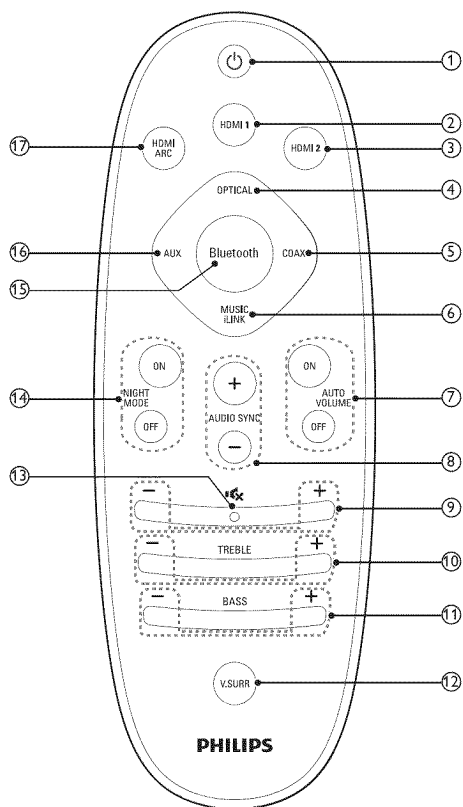

Switch your audio source to the coaxial connection.

- ⑥ **MUSIC iLINK**
Switch your audio source to the MUSIC iLINK connection.
- ⑦ **AUTO VOLUME ON/OFF**
Turn auto volume on or off.
- ⑧ **AUDIO SYNC +/-**
Increase or decrease audio delay.
- ⑨ **+/- (Volume)**
Increase or decrease volume.
- ⑩ **TREBLE +/-**
Increase or decrease treble.
- ⑪ **BASS +/-**
Increase or decrease bass.
- ⑫ **V.SURR**
Toggle between stereo and virtual surround sound.
- ⑬ **Mute**
Mute or restore volume.
- ⑭ **NIGHT MODE ON/OFF**
Turn night mode on or off.
- ⑮ **Bluetooth**
Switch to Bluetooth mode.
- ⑯ **AUX**
Switch your audio source to the AUX connection.
- ⑰ **HDMI ARC**
Switch your source to HDMI ARC connection. HDMI ARC can only be selected if you connect your SoundBar to an HDMI ARC compliant TV through HDMI ARC.

- ① **⏻ (Standby-On)**
 - Switch the SoundBar on or to standby.
 - When EasyLink is enabled, press and hold for at least three seconds to switch all connected HDMI CEC compliant devices to standby.

- ② **HDMI 1**
Switch your source to the HDMI IN 1 connection.

- ③ **HDMI 2**
Switch your source to the HDMI IN 2 connection.

- ④ **OPTICAL**
Switch your audio source to the optical connection.

- ⑤ **COAX**

Connectors

This section includes an overview of the connectors available on your SoundBar:

Rear connectors

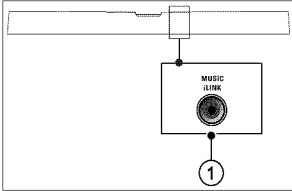

① MUSIC iLINK

Audio input from an MP3 player.

⑤ AUDIO IN-AUX

Connect to an analog audio output on the TV or an analog device.

⑥ DIGITAL IN-COAXIAL

Connect to a coaxial audio output on the TV or a digital device.

⑦ DIGITAL IN-OPTICAL

Connect to an optical audio output on the TV or a digital device.

Bottom connectors

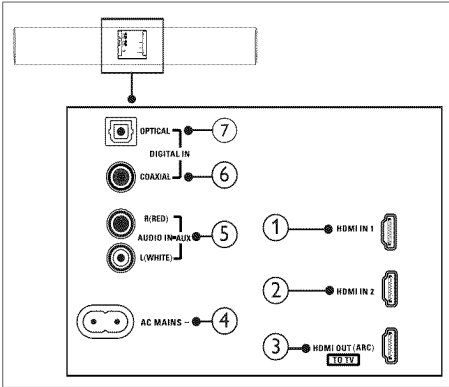

① HDMI IN 1

Connect to the HDMI output on a digital device.

② HDMI IN 2

Connect to the HDMI output on a digital device.

③ TO TV-HDMI OUT (ARC)

Connect to the HDMI input on the TV.

④ AC MAINS~

Connect to the power supply.

3 Connect

This section helps you connect your SoundBar to a TV and other devices.

For information about the basic connections of your SoundBar and accessories, see the quick start guide.



Note

- For identification and supply ratings, refer to the type plate at the back or bottom of the product.
- Before you make or change any connections, make sure that all devices are disconnected from the power outlet.

- The **HDMI ARC** connector on the TV might be labeled differently. For details, see the TV user manual.

- 2 On your TV, turn on **HDMI-CEC** operations. For details, see the TV user manual.



Note

- If your TV is not **HDMI ARC** compliant, connect an audio cable to hear the TV audio through your SoundBar: (see 'Connect audio from TV and other devices' on page 9)
- If your TV has a **DVI** connector, you can use an **HDMI/DVI** adapter to connect to TV. However, some of the features may not be available.

Connect to TV

Connect your SoundBar to a TV. You can listen to audio from TV programs through your SoundBar. Use the best quality connection available on your SoundBar and TV.

Connect to TV through HDMI (ARC)

Your SoundBar supports HDMI with Audio Return Channel (ARC). If your TV is HDMI ARC compliant, you can hear the TV audio through your SoundBar by using a single HDMI cable.

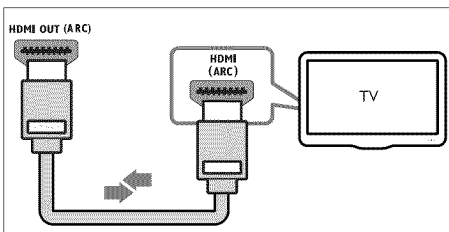

- 1 Using a High Speed HDMI cable, connect the **HDMI OUT (ARC)** connector on your SoundBar to the **HDMI ARC** connector on the TV.

Connect digital devices through HDMI

Connect a digital device such as a set-top box, DVD/Blu-ray player, or games console to your SoundBar through a single HDMI connection. When you connect the devices in this way and play a file or game, the

- video is automatically displayed on your TV, and
 - audio is automatically played on your SoundBar.
- 1 Using a High Speed HDMI cable, connect the **HDMI OUT** connector on your digital device to the **HDMI IN 1/2** on your SoundBar.
 - 2 Connect your SoundBar to TV through **HDMI OUT (ARC)**.
 - If the TV is not **HDMI CEC** compliant, select the correct video input on your TV.
 - 3 On the connected device, turn on **HDMI-CEC** operations. For details, see the user manual of the device.

Connect audio from TV and other devices

Play audio from TV or other devices through your Soundbar speakers.
Use the best quality connection available on your TV, Soundbar, and other devices.

Note

- When your Soundbar and TV are connected through HDMI ARC, an audio connection is not required.

Option 1: Connect audio through a digital optical cable

Best quality audio

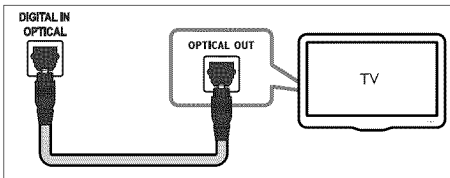

- 1 Using an optical cable, connect the **OPTICAL** connector on your SoundBar to the **OPTICAL OUT** connector on the TV or other device.
 - The digital optical connector might be labeled **SPDIF** or **SPDIF OUT**.

Option 2: Connect audio through a digital coaxial cable

Good quality audio

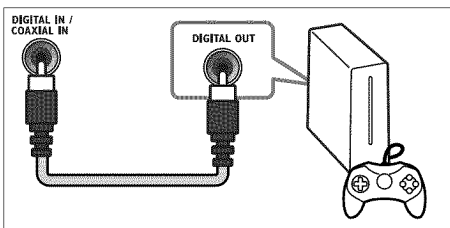

- 1 Using a coaxial cable, connect the **COAXIAL** connector on your SoundBar to the **COAXIAL/DIGITAL OUT** connector on the TV or other device.
 - The digital coaxial connector might be labeled **DIGITAL AUDIO OUT**.

Option 3: Connect audio through analog audio cables

Basic quality audio

- 1 Using an analog cable, connect the **AUX** connectors on your SoundBar to the **AUDIO OUT** connectors on the TV or other device.

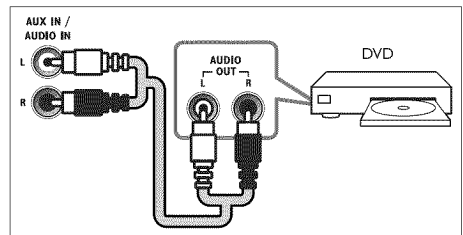

4 Use your SoundBar

This section helps you use the SoundBar to play audio from connected devices.

Before you start

- Make the necessary connections described in the quick start guide and the user manual.
- Switch the SoundBar to the correct source for other devices.

Adjust the volume

1 Press +/- (**Volume**) to increase or decrease a volume level.

- To mute sound, press **Mute**.
- To restore the sound, press **Mute** again or press +/- (**Volume**).

Volume indicator

- When you change volume, one or multiple **Volume indicator** (up to 8 indicators) on the main unit light up to indicate a volume level. The more indicators light up, the higher the volume level is.

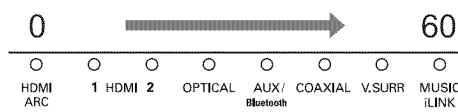

- If you do not press the volume key for five seconds, the volume indicators light off, and the current source indicator and the sound mode indicator light up.

Choose your sound

This section helps you choose the ideal sound for your video or music.

Surround sound mode

Experience an immersive audio experience with surround sound modes.

- 1 Press **V.SURR** repeatedly to switch surround mode on or off.
 - ↳ When surround mode is on, the **V.SURR** indicator on the main unit lights up. Creates a surround listening experience.
 - ↳ When the **V.SURR** indicator on the main unit turns off, two-channel stereo sound is on, ideal for listening to music.

Equalizer

Change the high frequency (treble) and low frequency (bass) settings of the SoundBar.

1 Press **TREBLE +/-** or **BASS +/-** to change the treble or bass level.

Treble/bass indicator

- When you change the treble or bass level, all the indicators on the main unit blink one by one. If the treble or bass level is set to the minimum, all the indicators turn off.

Auto volume

Turn the auto volume on to keep the volume constant when you switch to a different source.

- 1 Press **AUTO VOLUME ON/OFF** to turn auto volume on or off.
 - ↳ When auto volume is turned on or off, **V.SURR** indicator blinks once.

Synchronize picture and sound

If the audio and video are not synchronized, delay the audio to match the video.

- 1 Press **AUDIO SYNC +/-** to synchronize the audio with the video.

Night mode

For quiet listening, decrease the volume of loud sounds when audio is played. Night mode is only available for Dolby Digital soundtracks.

- 1 Press **NIGHT MODE ON/OFF** to turn night mode on or off.
 - ↳ When night mode is turned on or off, **V.SURR** indicator blinks once.



Note

- If auto volume is set to turned on, you cannot enable the night mode.

MP3 player

Connect your MP3 player to play your audio files or music.

What you need

- An MP3 player.
- A 3.5mm stereo audio cable.

- 1 Using the 3.5mm stereo audio cable, connect the MP3 player to the **MUSIC iLINK** connector on your SoundBar.
- 2 Press **MUSIC iLINK**.
- 3 Press the buttons on the MP3 player to select and play audio files or music.

Play audio through Bluetooth

Through Bluetooth, connect the SoundBar with your Bluetooth device (such as an iPad, iPhone, iPod touch, Android phone, or laptop), and then you can listen to the audio files stored on the device through your SoundBar speakers.

What you need

- A Bluetooth device which supports Bluetooth profile A2DP, and with Bluetooth version as 2.1 + EDR.

- The operational range between the SoundBar and a Bluetooth device is approximately 10 meters (30 feet).
- 1 Press **Bluetooth** on the remote control to switch the SoundBar to Bluetooth mode.
 - ↳ The **AUX/Bluetooth** indicator blinks at a fast rate.
 - 2 On the Bluetooth device, switch on Bluetooth, search for and select **Philips HTL5120** to start connection (see the user manual of the Bluetooth device on how to enable Bluetooth).
 - When prompted for a password, enter "0000".
 - ↳ During connection, the indicator blinks at a lower rate.
 - 3 Wait until you hear a beep sound from the SoundBar.
 - ↳ When the Bluetooth connection succeeds, and the **AUX/Bluetooth** indicator lights up.
 - ↳ If the connection fails, the **AUX/Bluetooth** indicator blinks continually at a lower rate.
 - 4 Select and play audio files or music on your Bluetooth device.
 - During play, if a call is coming, music play is paused. Play resumes when the call ends.
 - 5 To exit Bluetooth, select other source.
 - When your switch back to Bluetooth mode, Bluetooth connection remains active.



Note

- The music streaming may be interrupted by obstacles between the device and SoundBar, such as wall, metallic casing that covers the device, or other devices nearby that operate in the same frequency.
- If you want to connect your SoundBar with another Bluetooth device, disable the currently connected Bluetooth device.
- Philips does not guarantee 100% compatibility with all Bluetooth devices.

Auto standby

When playing media from a connected device, the SoundBar automatically switches to standby if:

- no source button is pressed for 30 minutes, and
- no audio/video playback is detected from a connected device.

Apply factory settings

You can reset your SoundBar to the default settings programmed at the factory.

- 1 Press **TREBLE+**, **VOL-**, and **BASS+** within three seconds.
 - ↳ When the factory settings restore is complete, the SoundBar automatically switches off and restarts.

5 Wall mount your SoundBar

Before you mount your SoundBar on the wall, read all safety precautions.

Wall mount



Note

- Koninklijke Philips Electronics N.V. bears no responsibility for improper wall mounting that results in accident, injury or damage. If you have any query, contact Philips Consumer Care in your country.
- Secure the wall mount to a wall that can support the combined weight of the product and the wall mount.
- Before wall mount, you need not remove the four rubber feet at the bottom of the soundbar; otherwise the rubber feet cannot be fixed back.

Screw length/diameter

Depend on the type of wall mounting this wall mount bracket, make sure that you use screws of a suitable length and diameter:

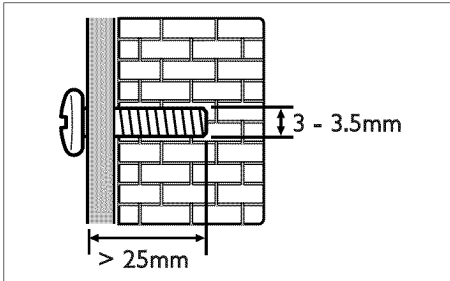

For information about how to wall your SoundBar, see the wall mount guide.

6 Product specifications

Note

- Specifications and design are subject to change without notice.

Amplifier

- FTC total output power: 42W
 - Woofer L + Woofer R: 32W (1% THD, 3ohm, 180Hz-6KHz)
 - Tweeter L + Tweeter R: 10W (1% THD, 12ohm, 7KHz-20KHz)
- RMS total output power:
 - 120W RMS (+/- 0.5 dB, 30%THD)
 - 96W RMS (+/- 0.5 dB, 10%THD)
- Frequency response: 20 Hz-20 kHz / ± 3 dB
- Signal-to-noise ratio: > 65 dB (CCIR) / (A-weighted)
- Input sensitivity:
 - AUX: 800 mV
 - Music iLink: 550 mV

Audio

- S/PDIF Digital audio input:
 - Coaxial: IEC 60958-3
 - Optical: TOSLINK

Bluetooth

- Bluetooth profiles: A2DP
- Bluetooth version: 2.1 + EDR

Main unit

- Power supply: 110-240V~, 50-60 Hz
- Power consumption: 40 W
- Standby power consumption: ≤ 0.5 W

- Speaker impedance:
 - Woofer: 3 ohm
 - tweeter: 12 ohm
- Speaker drivers: 2 x 102 mm (4") woofer + 2 x 25.4 mm (1") tweeter
- Dimensions (WxHxD): 1010 x 81 x 154 mm
- Weight: 3.9 kg

Wall mount

- Dimensions (WxHxD): 40 x 100 x 26.5 mm
- Weight: 0.1 kg/each

Remote control batteries

- 2 x AAA-R03-1.5 V

7 Troubleshooting



Warning

- Risk of electric shock. Never remove the casing of the product.

To keep the warranty valid, never try to repair the product yourself.

If you have problems using this product, check the following points before you request service.

If you still have a problem, get support at www.philips.com/support.

Main unit

The buttons on the SoundBar do not work.

- Disconnect the SoundBar from the power supply for a few minutes, then reconnect.

Sound

No sound from SoundBar speakers.

- Connect the audio cable from your SoundBar to your TV or other devices. However, you do not need a separate audio connection when:
 - the SoundBar and TV are connected through **HDMI ARC** connection, or
 - a device is connected to the **HDMI IN** connector on your SoundBar.
- Reset your SoundBar to its factory settings (see 'Apply factory settings' on page 12).
- On the remote control, select the correct audio input.
- Make sure that the SoundBar is not muted.

Distorted sound or echo.

- If you play audio from the TV through the SoundBar, make sure that the TV is muted.

Audio and video are not synchronized.

- Press **AUDIO SYNC +/-** to synchronize the audio with the video.

Bluetooth

A device cannot connect with the SoundBar.

- The device does not support the compatible profiles required for the SoundBar.
- You have not enabled the Bluetooth function of the device. See the user manual of the device on how to enable the function.
- The device is not correctly connected. Connect the device correctly. (see 'Play audio through Bluetooth' on page 11)
- The SoundBar is already connected with another Bluetooth device. Disconnect the connected device, then try again.

Quality of audio play from a connected Bluetooth device is poor.

- The Bluetooth reception is poor. Move the device closer to the SoundBar, or remove any obstacle between the device and the SoundBar.

The connected Bluetooth device connects and disconnects constantly.

- The Bluetooth reception is poor. Move the device closer to the SoundBar, or remove any obstacle between the device and the SoundBar.
- Turn off Wi-Fi function on the Bluetooth device to avoid interference.
- For some Bluetooth, the Bluetooth connection can be deactivated automatically to save power. This does not indicate any malfunction of the SoundBar.

8 Notice

This section contains the legal and trademark notices.

Notice of compliance

This set complies with the FCC rules, Part 15 and with 21 CFR 1040.10. Operation is subject to the following two conditions:

- ① **This device may not cause harmful interference, and**
- ② **This device must accept any interference received, including interference that may cause undesired operation.**

FCC rules

This equipment has been tested and found to comply with the limits for a Class B digital device, pursuant to part 15 of the FCC Rules. These limits are designed to provide reasonable protection against harmful interference in a residential installation. This equipment generates, uses and can radiate radio frequency energy and, if not installed and used in accordance with the instruction manual, may cause harmful interference to radio communications. However, there is no guarantee that interference will not occur in a particular installation. If this equipment does cause harmful interference to radio or television reception, which can be determined by turning the equipment off and on, the user is encouraged to try to correct the interference by one or more of the following measures:

- Relocate the receiving antenna.
- Increase the separation between equipment and receiver.
- Connect the equipment into an outlet on a circuit different from that to which the receiver is connected.
- Consult the dealer or an experienced radio/TV technician for help.

FCC Radiation Exposure Statement: This equipment complies with FCC radiation exposure limits set forth for an uncontrolled environment. This equipment should be installed and operated with a minimum distance of 20cm between the radiator and your body. This transmitter must not be co-located or operated in conjunction with any other antenna or transmitter.

Warning: Changes or modifications made to this equipment not expressly approved by Philips may void the FCC authorization to operate this equipment.

Model number: PHILIPS HTL5120/F7

Trade Name: Philips

Responsible Party: P&F USA, Inc. PO Box 2248 Alpharetta, GA 30023-2248; 1-866-310-0744

Canada:

This device complies with Industry Canada licence-exempt RSS standard(s). Operation is subject to the following Two conditions: (1) this device may not cause harmful interference, and (2) this device must accept any interference received, including interference that may cause undesired operation.

This Class B digital apparatus complies with Canadian ICES-003.

Trademarks

The logo for DTS Digital Surround, featuring the letters 'dts' in a stylized font with horizontal lines through them, and the words 'Digital Surround' below it.

Manufactured under license under U.S. Patent Nos: 5,956,674; 5,974,380; 6,487,535 & other U.S. and worldwide patents issued & pending. DTS, the Symbol, & DTS and the Symbol together are registered trademarks & DTS Digital Surround and the DTS logos are trademarks of DTS, Inc. Product includes software. © DTS, Inc. All Rights Reserved.

The logo for Dolby Digital, featuring the word 'DOLBY' in a bold, sans-serif font above the word 'DIGITAL' in a smaller, bold, sans-serif font, with a stylized 'D' symbol to the left.

Manufactured under license from Dolby Laboratories. Dolby and the double-D symbol are trademarks of Dolby Laboratories.



The Bluetooth® word mark and logos are registered trademarks owned by Bluetooth SIG, Inc. and any use of such marks by Philips is under license.



The terms HDMI and HDMI High-Definition Multimedia Interface, and the HDMI Logo are trademarks or registered trademarks of HDMI Licensing LLC in the United States and other countries.

ONE (1) YEAR LIMITED WARRANTY

WARRANTY COVERAGE:

This warranty obligation is limited to the terms set forth below.

WHO IS COVERED:

This product is warranted to the original purchaser or the person receiving the product as a gift against defects in materials and workmanship as based on the date of original purchase ("Warranty Period") from an Authorized Dealer. The original sales receipt showing the product name and the purchase date from an authorized retailer is considered such proof.

WHAT IS COVERED:

This warranty covers new products if a defect in material or workmanship occurs and a valid claim is received within the Warranty Period. At its option, the company will either (1) repair the product at no charge, using new or refurbished replacement parts, or (2) exchange the product with a product that is new or which has been manufactured from new, or serviceable used parts and is at least functionally equivalent or most comparable to the original product in current inventory, or (3) refund the original purchase price of the product. The company warrants replacement products or parts provided under this warranty against defects in materials and workmanship from the date of the replacement or repair for ninety (90) days or for the remaining portion of the original product's warranty, whichever provides longer coverage for you. When a product or part is exchanged, any replacement item becomes your property and the replaced item becomes the company property. When a refund is given, your product becomes the company property. **Note: Any product sold and identified as refurbished or renewed carries a ninety (90) day limited warranty.**

Replacement product can only be sent if all warranty requirements are met. Failure to follow all requirements can result in delay.

WHAT IS NOT COVERED - EXCLUSIONS AND LIMITATIONS:

This Limited Warranty applies only to the new products that can be identified by the trademark, trade name, or logo affixed to it. This Limited Warranty does not apply to any non-Philips hardware product or any software, even if packaged or sold with the product. Non-Philips manufacturers, suppliers, or publishers may provide a separate warranty for their own products packaged with the bundled product.

The company is not liable for any damage to or loss of any programs, data, or other information stored on any media contained within the product, or any non-Philips product or part not covered by this warranty. Recovery or reinstallation of programs, data or other information is not covered under this Limited Warranty.

This warranty does not apply (a) to damage caused by accident, abuse, misuse, neglect, misapplication, or non-Philips product, (b) to damage caused by service performed by anyone other than an Authorized Service Location, (c) to a product or a part that has been modified without written permission,

or (d) if any serial number has been removed or defaced, or (e) product, accessories or consumables sold "AS IS" without warranty of any kind by including refurbished Philips product sold "AS IS" by some retailers.

This Limited Warranty does not cover:

- Shipping charges to return defective product.
- Labor charges for installation or setup of the product, adjustment of customer controls on the product, and installation or repair of antenna/signal source systems outside of the product.
- Product repair and/or part replacement because of improper installation or maintenance, connections to improper voltage supply, power line surge, lightning damage, retained images or screen markings resulting from viewing fixed stationary content for extended periods, product cosmetic appearance items due to normal wear and tear, unauthorized repair or other cause not within the control of the company.
- Damage or claims for products not being available for use, or for lost data or lost software.
- Damage from mishandled shipments or transit accidents when returning product.
- A product that requires modification or adaptation to enable it to operate in any country other than the country for which it was designed, manufactured, approved and/or authorized, or repair of products damaged by these modifications.
- A product used for commercial or institutional purposes (including but not limited to rental purposes).
- Product lost in shipment and no signature verification receipt can be provided.
- Failure to operate per Owner's Manual.

TO OBTAIN ASSISTANCE IN THE U.S.A., CANADA, PUERTO RICO, OR U.S. VIRGIN ISLANDS...

Contact Customer Care Center at:

1-866-310-0744

REPAIR OR REPLACEMENT AS PROVIDED UNDER THIS WARRANTY IS THE EXCLUSIVE REMEDY FOR THE CONSUMER. PHILIPS SHALL NOT BE LIABLE FOR ANY INCIDENTAL OR CONSEQUENTIAL DAMAGES FOR BREACH OF ANY EXPRESS OR IMPLIED WARRANTY ON THIS PRODUCT. EXCEPT TO THE EXTENT PROHIBITED BY APPLICABLE LAW, ANY IMPLIED WARRANTY OF MERCHANTABILITY OR FITNESS FOR A PARTICULAR PURPOSE ON THIS PRODUCT IS LIMITED IN DURATION TO THE DURATION OF THIS WARRANTY.

Some states do not allow the exclusions or limitation of incidental or consequential damages, or allow limitations on how long an implied warranty lasts, so the above limitations or exclusions may not apply to you.

This warranty gives you specific legal rights. You may have other rights which vary from state/province to state/province.

P&F USA Inc. PO Box 2248 Alpharetta, GA 30023-2248

P&F USA, Inc.
PO Box 2248 Alpharetta, GA 30023-2248

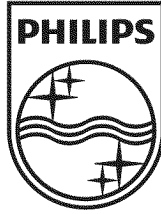

Specifications are subject to change without notice
© 2013 Koninklijke Philips Electronics N.V.
All rights reserved.

HTL5120_F7_UM_V1.0

