

# OWNER'S MANUAL

*Operating and Servicing Instructions*

Español - página E1



www.hoover.com

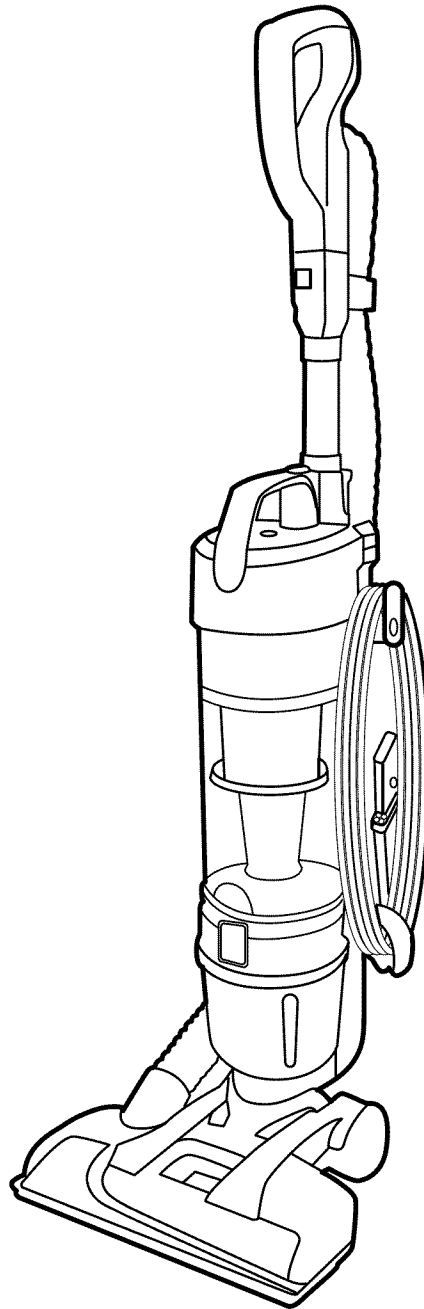

---

**IMPORTANT: READ CAREFULLY BEFORE ASSEMBLY AND USE.**

Questions or concerns? For assistance, please call Customer Service at 1-800-944-9200  
Mon-Fri 8am-7pm EST. **PLEASE DO NOT RETURN THIS PRODUCT TO THE STORE.**

---

**THIS PRODUCT IS INTENDED FOR HOUSEHOLD USE ONLY.  
IF USED COMMERCIALY WARRANTY IS VOID.**

---

Thank you for choosing a HOOVER® product.

Please enter the complete model and manufacturing code in the spaces provided.

MODEL \_\_\_\_\_

MFG. CODE \_\_\_\_\_

Hint: Attach your sales receipt to this owner's manual. Verification of date of purchase may be required for warranty service of your HOOVER® product.

Be sure to register your product online at Hoover.com or call 1-800-944-9200 to register by phone.

**MANUFACTURING CODE**  
(Label located on bottom of vacuum)

## CONTENTS

<b>Important Safety Instructions</b> .....	<b>3</b>
<b>Vacuum Assembly</b> .....	<b>5</b>
Carton Contents.....	5
Attach Handle.....	5
Attach Dirt Cup.....	5
Position Tools.....	5
<b>How To Use</b> .....	<b>6</b>
Vacuum Description.....	6
On-Off Switch.....	6
Carry Handle.....	6
Cord Storage.....	6
Handle Positions.....	7
<b>Hose And Tool Use</b> .....	<b>7</b>
Hose Mode.....	7
Handles.....	8
Select Proper Tool.....	8
Stair Cleaning.....	9
How To Clean Tools.....	9
<b>Maintenance</b> .....	<b>10</b>
Dirt Cup.....	10
Filters.....	10-11
Brushroll.....	12
Belt.....	13
Air-Powered Hand Tool.....	13
<b>Troubleshooting</b> .....	<b>14</b>
<b>Service</b> .....	<b>15</b>
<b>Warranty</b> .....	<b>16</b>

### If you need assistance:

Visit our website at hoover.com. Follow the authorized dealer locator link to find the Hoover® authorized dealer nearest you or call 1-800-944-9200 for an automated referral of Hoover® authorized dealer locations (U.S. only) or to speak with a customer service representative; Mon- Fri 8am- 7pm EST.

**PLEASE DO NOT RETURN THIS PRODUCT TO THE STORE.**

# IMPORTANT SAFETY INSTRUCTIONS

## SAVE THESE INSTRUCTIONS

When using an electrical appliance, basic precautions should always be followed, including the following:

**READ ALL INSTRUCTIONS BEFORE USING THIS APPLIANCE.**

### **WARNING: TO REDUCE THE RISK OF FIRE, ELECTRIC SHOCK OR INJURY:**

- Fully assemble before operating.
- Operate vacuum only at voltage specified on data label on bottom of cleaner.
- Do not leave appliance when plugged in. Unplug from outlet when not in use and before cleaning or servicing.
- Do not use outdoors or on wet surfaces.
- Do not allow to be used as a toy. Not intended for use by children age 12 and under. Close supervision is necessary when used near children. To avoid injury or damage, keep children away from product, and do not allow children to place fingers or other objects into any openings.
- Use only as described in this manual. Use only manufacturer's recommended attachments and products.
- Do not use with damaged cord or plug. If appliance is not working as it should, has been dropped, damaged, left outdoors, or dropped into water, take it to a service center prior to continuing use.
- Do not pull or carry by cord, use cord as a handle, close a door on cord, or pull cord around sharp edges or corners. Do not place product on cord. Do not run appliance over cord. Keep cord away from heated surfaces.
- Do not unplug by pulling on cord. To unplug, grasp the plug, not the cord.
- Do not handle plug or appliance with wet hands.
- Do not put any object into openings. Do not use with any opening blocked; keep free of dust, lint, hair, and anything that may reduce air flow.
- Keep hair, loose clothing, fingers, and all parts of body away from openings and moving parts.
- Turn off all controls before unplugging.
- Use extra care when cleaning on stairs. To avoid personal injury or damage, and to prevent the cleaner from falling, always place cleaner at bottom of stairs on floor. Do not place cleaner on stairs or furniture, as it may result in injury or damage.
- Do not use to pick up flammable or combustible liquids, such as gasoline, or fine wood sandings, or use in areas where they may be present.
- Do not pick up anything that is burning or smoking, such as cigarettes, matches, or hot ashes.
- Do not use without Dirt Cup and/or Filters in place.
- Unplug before connecting Air-Powered Hand Tool.
- **WARNING:** This product contains chemicals known to the State of California to cause cancer, birth defects or reproductive harm. **WASH HANDS AFTER HANDLING.**

## **CAUTION: TO REDUCE THE RISK OF DAMAGE:**

- Avoid picking up hard, sharp objects with this product, as they may cause damage.
- Do not use sharp objects to clean out hose as they can cause damage.
- Store appropriately indoors in a dry place. Do not expose machine to freezing temperatures.
- With brushroll on, do not allow cleaner to sit in one location for an extended period of time, as damage to floor can result.

## **WARNING:**

- To reduce the risk of electric shock, this appliance has a polarized plug (one blade is wider than the other). This plug will fit in a polarized outlet only one way. If the plug does not fit fully in the outlet, reverse the plug. If it still does not fit, contact a qualified electrician to install the proper outlet. Do not change the plug in any way.

# 1. VACUUM ASSEMBLY

## CARTON CONTENTS

- A. Handle / Hose Assembly
- B. Wand
- C. Vacuum Base and Dirt Cup
- D. 2-in-1 Combination Tool
- E. Air-Powered Hand Tool\*

Remove all parts from carton and identify each item shown.

Make sure all parts are located before disposing of packing materials.

\*Available on select models only

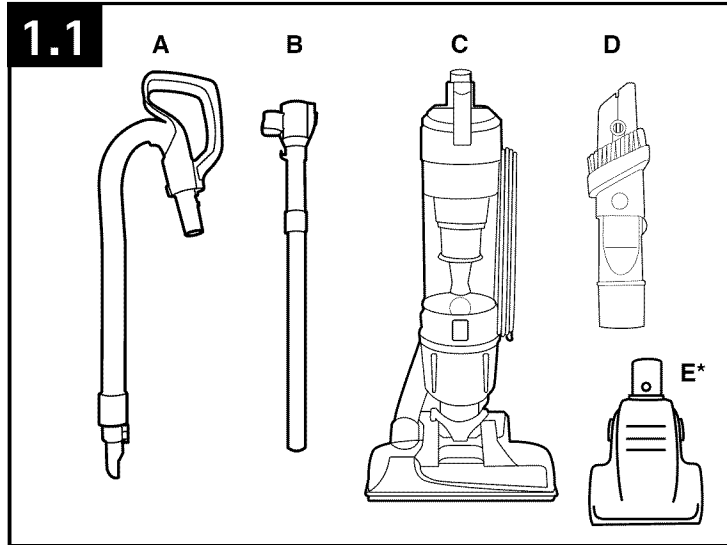

## ATTACH HANDLE

1.2 Insert handle section into vacuum base.

1.3 To remove handle press button on back of unit and pull handle out of vacuum base.

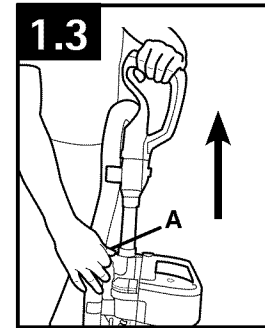
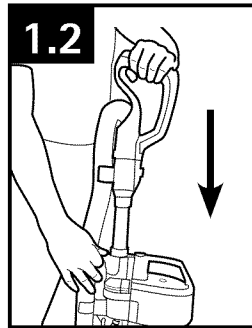

## ATTACH DIRT CUP

1.4 Place bottom of dirt cup into vacuum body first. Pivot into vacuum.

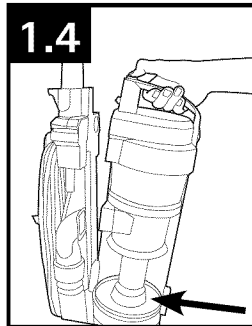

## POSITION TOOLS

1.5 For storage mode, push dusting brush all the way down onto crevice tool.

1.6 Assemble combination tool onto post located on side of vacuum.

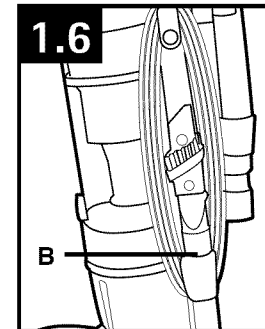
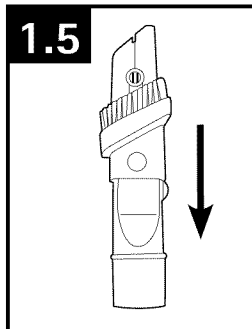

## 2. HOW TO USE

### VACUUM DESCRIPTION

1. D-Grip Handle
2. Short Handle Release Button
3. Wand
4. Dirt Cup Release Button
5. Carry Handle
6. Dirt Cup
7. Filter made with HEPA media
8. Brushroll Window
9. Hose Port (above floor cleaning)
10. ON/OFF Power Switch
11. Brushroll ON/OFF Switch
12. Cord Clip
13. Hose
14. Wand/Handle Release Button
15. Cord Release
16. Cord
17. 2-in-1 Combination Tool
18. Hose Connector
19. Furniture Guard
20. Rinsable Filter Access

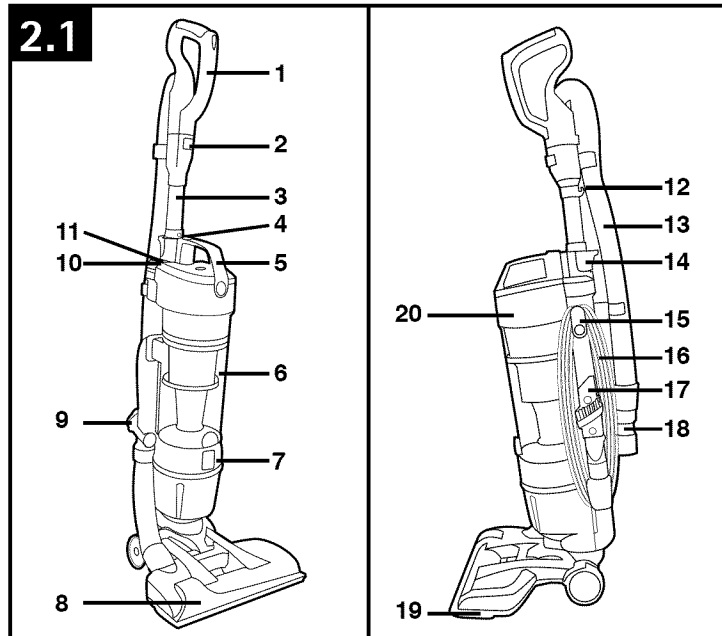

Operate cleaner only at voltage specified on data plate on bottom of cleaner.

This cleaner is intended for household use.

\*Available on select models only

### ON-OFF SWITCH

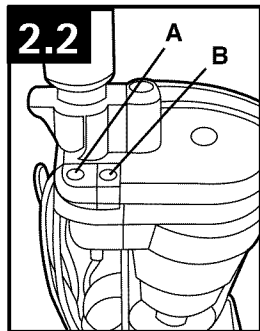

Plug cord into electrical outlet.

To turn vacuum ON, push ON/OFF switch (A) once. To turn vacuum OFF, push switch again.

To turn brushroll ON, push ON/OFF switch (B) once. To turn brushroll OFF, push switch again.

NOTE: Brushroll does not run with vacuum in the upright position.

### CARRY HANDLE

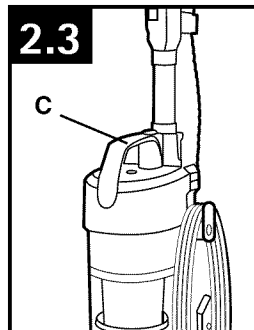

The cleaner can be moved by using the carry handle (C).

### CORD STORAGE

2.4 Wrap cord on cord hooks for convenient storage.

Attach the plug end to the cord.

2.5 Twist upper cord hook (D) to allow cord to be released.

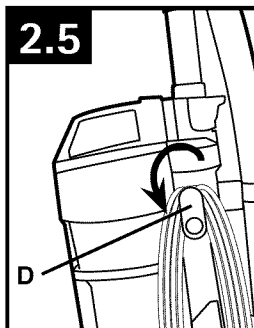
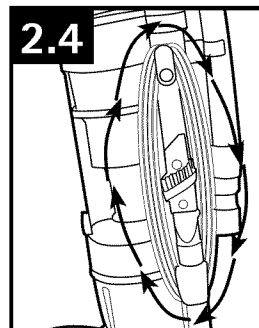

## HANDLE POSITIONS

2.6 The handle of your cleaner has two positions: upright for storage and when using cleaning tools; operating position for general operation on carpet and floors; hold nozzle with foot (E) and pull handle back.

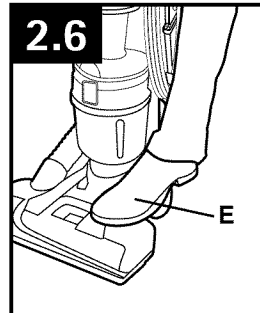

### ⚠ CAUTION ⚠

Not to be used for grooming a pet.

## 3. HOSE AND TOOL USE

Tools allow for cleaning surfaces above the floor and for reaching hard to clean areas. The vacuum is ready for tool use when handle is in upright position.

### ⚠ WARNING ⚠

Unplug vacuum before connecting hose, wand or tools.

### HOSE MODE (Above Floor Cleaning)

Cleaner must be in the upright position.

3.1 Remove the hose connector (A) from storage position.

3.2 Plug in hose connector by flipping down hose connector door (B) insert hose connector (A) until it clicks.

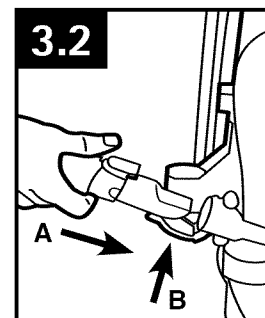
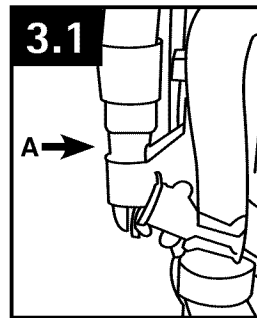

### ⚠ CAUTION ⚠

Hose connector must be removed and placed back into storage position for general operation on floors.

# HANDLES

## D-Grip Wand/Handle Release

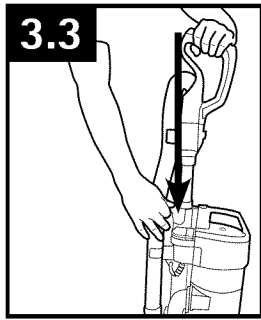

3.3 Press handle release button down to release handle from unit.

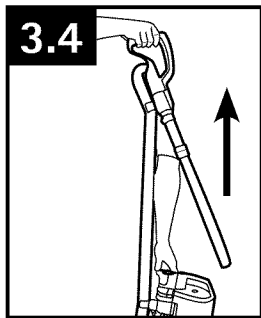

3.4 Pull handle up and out of unit.

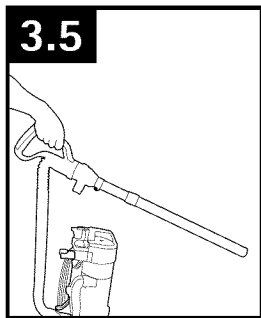

3.5 Hold handle wand by top of grip for easy reach cleaning. Tools can be attached to end of wand if desired.



## D-Grip Handle Release

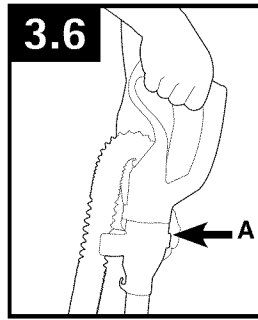

3.6 Push button (A) to release handle grip.

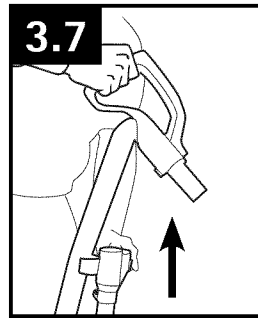

3.7 Pull handle up and out of unit.

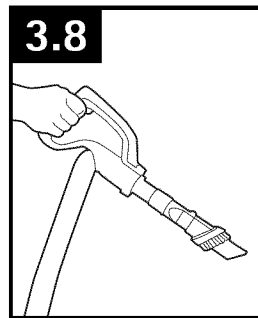

3.8 Tools can be attached to short wand if desired.



## SELECT PROPER TOOL 2-in-1 Combination Tool

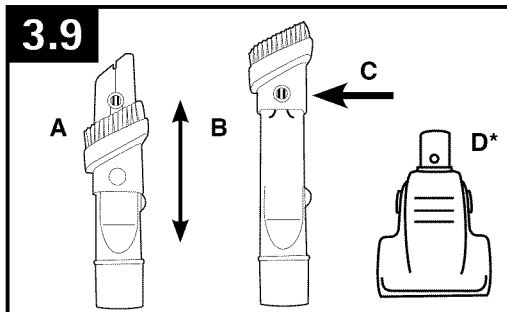

3.9 Simply push the attachment firmly on the end of the wand or hose end. To remove tool, twist and pull apart gently and return to storage.

A. Crevice Tool may be used in tight spaces, corners and along edges in such places as dresser drawers, upholstered furniture, stairs and baseboards.

B. Dusting Brush may be used for furniture, table tops, books, lamps, lighting fixtures, venetian blinds, baseboards, shutters, and registers.

C. Push lock button in to release dusting brush and slide down to revert to crevice mode.

D. Air-Powered Hand Tool may be used for upholstered furniture, draperies, mattresses, clothing, and carpeted stairs. (Tool varies per model\*)

\*Available on select models only



## STAIR CLEANING

3.10 The hose and tools can be used for stair cleaning.

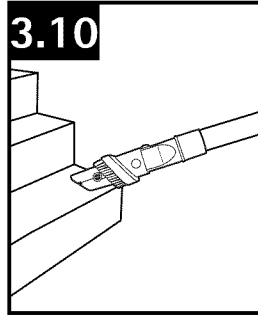

### **⚠ CAUTION ⚠**

Use extra care when cleaning on stairs. To avoid personal injury or damage, and to prevent the cleaner from falling, always place cleaner at bottom of stairs or on floor. Do not place cleaner on stairs or furniture, as it may result in injury or damage. When using tools, always ensure handle is in upright position.

---

## HOW TO CLEAN TOOLS

To clean Hose and Air-Powered Hand Tool, wipe with a damp cloth. DO NOT submerge in water.

Other cleaning tools may be washed in warm water with a mild detergent. Rinse and air dry 24 hours before using.

## 4. MAINTENANCE

Familiarize yourself with these home maintenance tasks as proper use and care of your vacuum will ensure continued cleaning effectiveness.

Any other servicing should be done by an authorized service representative.

If appliance is not working as it should, has been dropped, damaged, left outdoors, or dropped into water, return it to a service center prior to continuing use.

### DIRT CUP: When to Empty

4.1 Empty the dirt cup before the dirt cup reaches the max line (A). Place the vacuum in the upright position before removing the dirt cup.

#### ⚠ WARNING ⚠

To reduce the risk of personal injury - Unplug before cleaning or servicing. Do not use vacuum without dirt cup or filters in place.

Very fine materials, such as face powder or cornstarch, may seal the filter and cause a reduction in performance. When using the vacuum for this type of dust, empty the cup and clean the filters often.

### DIRT CUP: How to Empty

4.2 Press dirt cup release button and pivot cup out.

4.3 Hold dirt cup over trash receptacle, push dirt cup door release lever (A) to open dirt cup door (B).

Close dirt cup door (B). Press firmly to secure.

4.4 Place bottom of dirt cup into vacuum body first. Pivot dirt cup into vacuum. Press down on the dirt cup release button to secure into place.

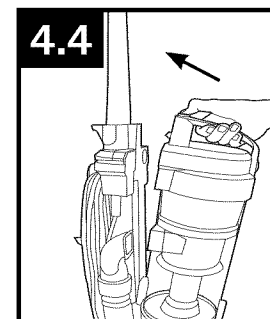
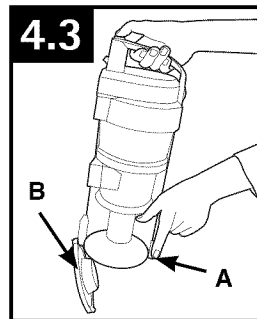
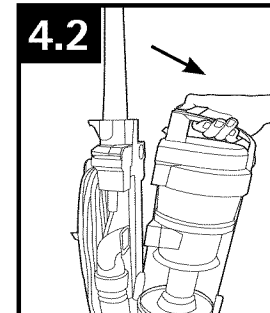
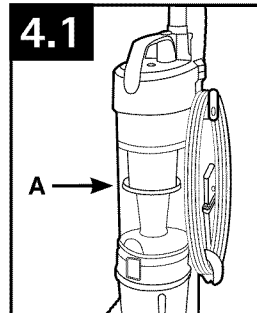

### FILTERS: When to Clean

To maintain optimal performance, filters should be cleaned every two months under normal use.

#### ⚠ WARNING ⚠

To reduce the risk of personal injury - Unplug before cleaning or servicing. Do not use vacuum without dirt cup or filters in place.

### Rinsable Filter: How to Clean

Remove dirt cup as described in Fig. 4.2.

4.5 Twist the dirt cup lid to open.

4.6 Remove rinsable filter.

Rinse with water for two minutes or until water runs clear. Then squeeze out excess water. **Allow 24 hours for filter to dry completely.**

Replace filter.

Close lid securely by twisting dirt cup lid until it clicks as shown in Fig. 4.5.

Replace dirt cup as described in Fig 4.4.

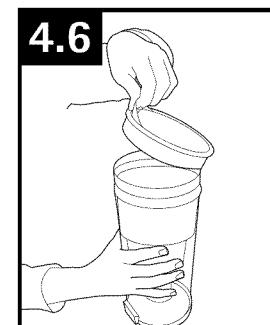
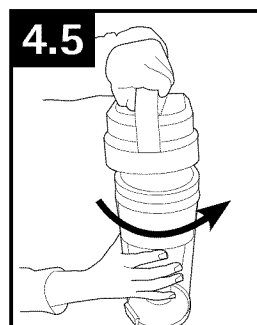

### Rinsable Filter: What to Buy

When used and maintained properly, your Rinsable Filter should not need replacement within the warranty period. If desired, additional filter is available. Ask for Hoover® Part No. 303903001.

#### • IMPORTANT •

Allow filter to dry completely before replacing. Dry filter on edge so air circulates on both sides of filter. This may take up to 24 hours.

## Filter Made With HEPA Media: How to Clean

### ⚠ WARNING ⚠

To reduce the risk of personal injury - Unplug before cleaning or servicing. Do not use vacuum without dirt cup or filters in place.

4.7 Remove dirt cup.

4.8 Unlock final filter cover by twisting filter counter-clockwise to remove.

4.9 Lift filter cover from the filter housing.

5.0 Pull filter out and hold over a trash receptacle. Tap out dirt and debris.

5.1 Replace filter cover by twisting clock-wise while it snaps in place.

5.2 Filter cover installed correctly when aligned with motorhousing.

Replace dirt cup on vacuum.

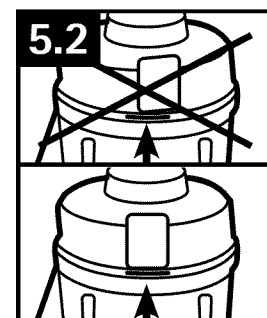
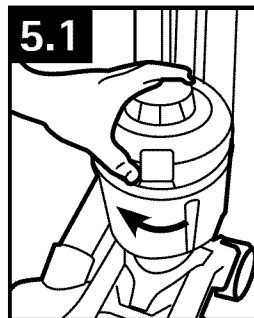
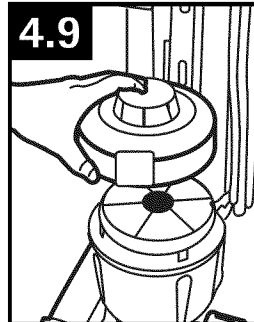
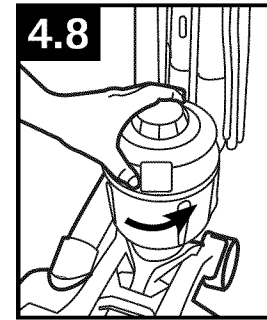
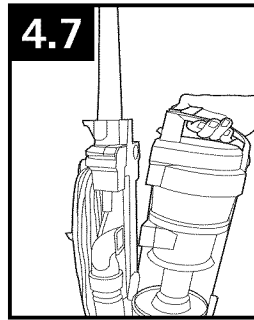

### • IMPORTANT •

DO NOT RINSE OR WASH THE FILTER CARTRIDGE.

#### Filter Made With HEPA Media:

##### What to Buy

When used and maintained properly, your Filter should not need replacement within the warranty period. If desired, additional filter is available. Ask for Hoover® Part No. 440003905.

## CYCLONIC FILTER ASSEMBLY: How to Clean

### **! WARNING !**

To reduce the risk of personal injury - Unplug before cleaning or servicing.

Remove dirt cup as described in Fig. 4.5.

4.11 Lift the filter assembly (A) up out of the dirt cup.

4.12 Dirt and debris can be cleaned from the filter assembly with the dusting/ upholstery tool.

4.13 Place the filter assembly (A) in the dirt cup, aligning the D-shaped tab on the top of the dirt cup. Press down firmly to place the filter assembly back in place. Replace dirt cup lid.

Replace dirt cup as described in Fig. 4.4.

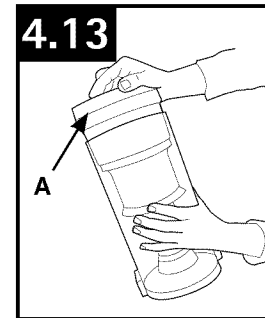
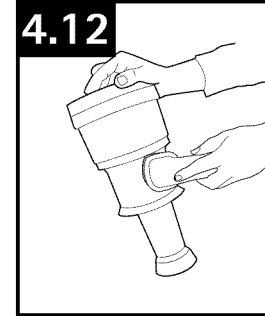
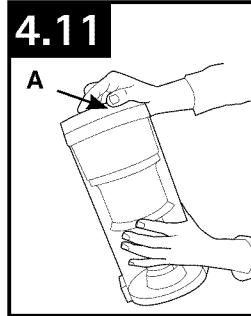

## BRUSHROLL: How to Clean

### **! CAUTION !**

To reduce the risk of injury from moving parts - Unplug before servicing.

4.14 Turn vacuum over so bottom side is facing up. Remove any debris and/or hair from brushroll.

For additional maintenance required for belt or brushroll please contact a HOOVER® service provider at 1-800-944-9200.

4.15 Vacuum is equipped with an automatic brushroll shut off in event of overload or jam.

4.16 To reset the brushroll, press the ON/OFF Brushroll switch OFF. Then press the ON/OFF Brushroll switch again to ON. After resetting the brushroll may still be blocked. Check for obstructions in the brushroll area and remove any obstructions.

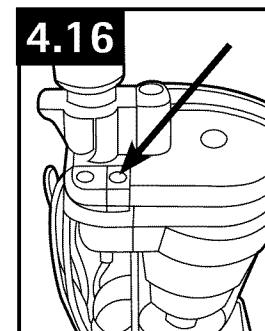
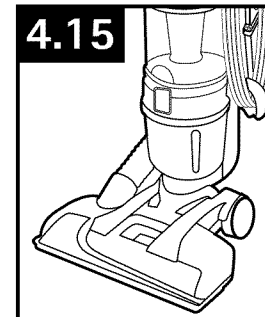
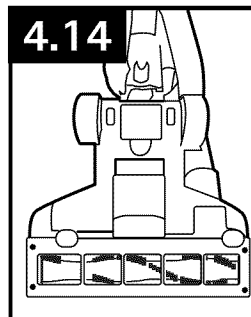

## BELT

### ⚠ CAUTION ⚠

To reduce the risk of injury from moving parts - Unplug before servicing.

The belt is located under the bottom plate of the vacuum and should be checked from time to time to be sure it is in good condition.

### When To Replace

Replace belt if it is damaged, cut or broken. To check the damaged belt, refer to Fig. 4.17 - 4.18.

### How To Replace

Place handle in the operating position and turn the cleaner over so the bottom side is up.

4.17 Remove the 4 screws as shown with a Phillips screwdriver.

4.18 Lift off bottom plate (A).

4.19 Remove agitator brushroll and used belt. Discard used belt.

4.20 With the lettering on the outside of the belt and positioned as shown place belt in belt guide on the agitator. Should the agitator become dislodged while replacing the belt, reposition it as shown. Grasp agitator firmly and fit it into position by first sliding end opposite of belt into the rectangular slot on side of cleaner. Pull other side of agitator into place. Turn the agitator making sure the belt is not pinched between agitator and agitator shield.

4.21 Place the bottom plate aligning the screw holes and install the 4 screws as shown.

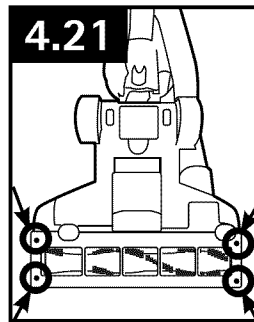
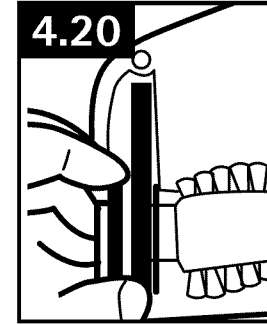
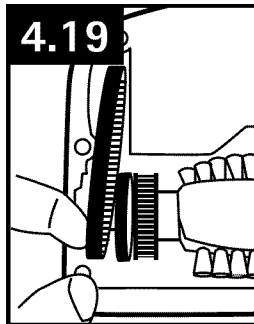
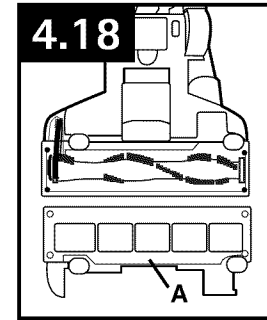
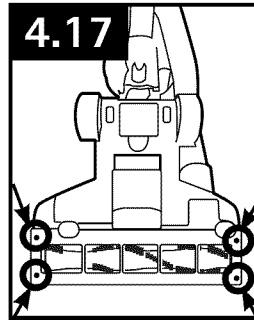

### Belt: What to Buy

Use only genuine HOOVER® belts with your vacuum. When purchasing a new belt, ask for Belt - HOOVER® part No. 562535001.

## LUBRICATION:

The motor and brushroll are equipped with bearings which contain sufficient lubrication for their lifetime. The addition of lubricant could cause damage. Do not add lubricant to motor or brushroll.

## AIR-POWERED HAND TOOL\*:

### How to Clean

(Tool varies per model)

### ⚠ CAUTION ⚠

To reduce the risk of injury from moving parts - Unplug before servicing.

4.15 Turn tool so bottom faces up. Rotate the latches (A) on either side of tool.

4.16 Remove bottom plate (B).

4.17 Remove any debris and/or hair from brushroll. Replace bottom plate by aligning tabs along front edge of tool. Rotate latches back into locked position.

\*Available on select models only

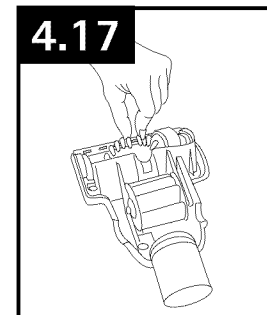
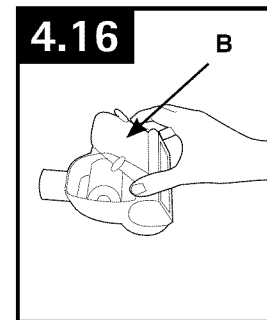
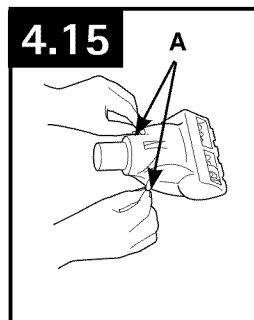

## 5. TROUBLESHOOTING

If a minor problem occurs, it usually can be solved quite easily when the cause is found by using the checklist below.

Any other servicing should be done by an authorized service representative.

If appliance is not working as it should, has been dropped, damaged, left outdoors, or dropped into water, return it to a service center prior to continuing use.

### ⚠ WARNING ⚠

To reduce the risk of personal injury - Unplug before cleaning or servicing.

PROBLEM	POSSIBLE CAUSE	POSSIBLE SOLUTION
<b>Vacuum won't run</b>	1. Power cord not firmly plugged into outlet.	1. Plug unit in firmly.
	2. No voltage in wall plug.	2. Check fuse or breaker in home.
	3. Blown fuse or tripped breaker.	3. Check fuse or breaker in home. Replace fuse/reset breaker in home.
	4. Thermal Protector activated.	4. Unplug and allow vacuum to cool for 30min. (This will reset the thermal protector)
	5. Automatic brushroll shut-off engaged	5. Press brushroll ON/OFF switch twice.
<b>Vacuum won't pick up or Low suction</b>	1. Dirt Cup full and/ or clogged.	1. Empty dirt cup - Pg.10.
	2. Brushroll and/ or hose clogged.	2. Check hose. Check brushroll - Pg.7-12.
	3. Rinsable filter and/ or filter made with HEPA media is dirty.	3. Clean rinsable filter and or filter made with HEPA media - Pg.10-11.
	4. Automatic brushroll shut-off engaged.	4. Press brushroll ON/OFF switch twice.
	5. Broken or worn belt.	5. Replace belt - Pg.13.
<b>Dust escaping from vacuum</b>	1. Dirt cup full.	1. Empty dirt cup - Pg. 10.
	2. Dirt cup not installed correctly.	2. Review dirt cup removal & replacement - Pg. 10.
	3. Hose not installed correctly.	3. Review hose installation - Pg. 7-8.
	4. Rinsable and/ or filter made with HEPA media not installed completely or missing.	4. Review filter removal and cleaning - Pg. 10-11.
<b>Air-Powered Hand Tool* brushroll won't turn</b>	1. Too much pressure being applied to tool.	1. Continue using tool applying light pressure.
	2. Blockage.	2. Remove blockage.
	3. Low vacuum suction.	3. Check items under "Vacuum won't pick up or Low suction."
<b>Brushroll will not turn</b>	1. Brushroll switch is off	1. Press the brushroll on/off switch - pg 12
	2. Brushroll is clogged.	2. Clear/ remove debris from brushroll - pg 12-13
	3. Brushroll does not work.	3. Unplug unit, wait 30 minutes - pg 4
<b>Smoky/burning smell detected</b>	1. Belt broken or stretched.	1. Replace brushroll belt - Pg. 12-13.
	2. Brushroll is clogged.	2. Clear/ remove debris from brushroll - Pg. 12-13.

\*Available on select models only

## ⚠ NOTICE ⚠

A Thermal Protector has been designed into your cleaner to protect it from overheating. When the thermal protector activates the cleaner will stop running.

If this happens proceed as follows:

1. Turn cleaner OFF and unplug it from the electrical outlet.
2. Empty dirt cup.
3. Inspect the nozzle inlet, hose connector, hose, dirt cup inlet, cyclonic filter, rinsable filter, and HEPA filter for any obstructions. Clear obstructions if present.

When cleaner is unplugged and motor has cooled for 30 minutes, the thermal protector will deactivate and cleaning may continue.

If the thermal protector continues to activate after following the above steps, your cleaner needs servicing.

## 6. SERVICE

To obtain approved Hoover® service and genuine Hoover® parts, locate the nearest Authorized Hoover® Warranty Service Dealer (Depot) by:

- Checking the Yellow Pages under "Vacuum Cleaners" or "Household".
- Visit our website at [hoover.com](http://hoover.com) (U.S. Customers) or [hoover.ca](http://hoover.ca) (Canadian customers).  
Follow the service center link to find the service outlet nearest you.
- For an automated referral of authorized service outlet locations call 1-800-944-9200.

Do not send your vacuum to Hoover®, Inc., Company in Glenwillow for service. This will only result in delay.

### **If you need further assistance:**

To speak with a customer service representative call 1-800-944-9200; Mon-Fri 8am-7pm EST. In Canada, contact Hoover® Canada, Toronto: 755 Progress Ave., Scarborough, ON M1H 2W7 OR Hoover® Canada, Edmonton: 18129-111 Ave., Edmonton, AB T5W 2P2, Phone: 1-800-944-9200, Mon-Fri 8am-7pm EST. Always identify your vacuum by the complete model number when requesting information or ordering parts. (The model number appears on the bottom of the vacuum.)

Please do not return this product to the store.

# 7. WARRANTY

## LIMITED FIVE YEAR WARRANTY

(Domestic Use)

### WHAT THIS WARRANTY COVERS

When used and maintained in normal household use and in accordance with the Owner's Manual, your HOOVER® product is warranted against original defects in material and workmanship for a full five year from date of purchase (the "Warranty Period"). During the Warranty Period, Hoover® will provide labor and parts, at no cost to you, to correct any such defect in products purchased in the United States, U.S. Military Exchanges and Canada.

### HOW TO MAKE A WARRANTY CLAIM

If this product is not as warranted, take or send the product to either a Hoover® Sales and Service Center or Hoover® Authorized Warranty Service Dealer along with proof of purchase. For an automated referral to authorized service outlets in the U.S.A., phone: 1-800-944-9200 OR visit Hoover® online at [www.hoover.com](http://www.hoover.com). For additional assistance or information concerning this Warranty or the availability of warranty service outlets, phone the Hoover® Consumer Response Center, Phone 1-800-944-9200, Mon-Fri 8am-7pm EST. In Canada, contact Hoover® Canada, Carson Building, 100 Carson St., Etobicoke, Ontario M8W 3R9, Phone: 1-800-944-9200, Mon-Fri 8am-7pm EST.

### WHAT THIS WARRANTY DOES NOT COVER

This Warranty does not cover: use of the product in a commercial operation (such as maid, janitorial and equipment rental services), brushroll, belt, improper maintenance of the product, damage due to misuse, acts of God, nature, vandalism or other acts beyond the control of Hoover®, owner's acts or omissions, use outside the country in which the product was initially purchased and resales of the product by the original owner. This warranty does not cover pick up, delivery,

transportation or house calls. However, if you mail your product to a Hoover® Sales and Service Center for warranty service, cost of shipping will be paid one way.

This warranty does not apply to products purchased outside the United States, including its territories and possessions, outside a U.S. Military Exchange and outside of Canada. This warranty does not cover products purchased from a party that is not an authorized retailer, dealer, or distributor of Hoover® products.

### OTHER IMPORTANT TERMS

This Warranty is not transferable and may not be assigned. This Warranty shall be governed and construed under the laws of the state of Ohio. The Warranty Period will not be extended by any replacement or repair performed under this Warranty.

THIS WARRANTY IS THE EXCLUSIVE WARRANTY AND REMEDY PROVIDED BY HOOVER®. ALL OTHER WARRANTIES, EXPRESSED OR IMPLIED, INCLUDING WARRANTIES OF MERCHANTABILITY OR FITNESS FOR PARTICULAR PURPOSE, ARE DISCLAIMED. IN NO EVENT WILL HOOVER BE LIABLE FOR ANY SPECIAL, INDIRECT, INCIDENTAL OR CONSEQUENTIAL DAMAGES OF ANY KIND OR NATURE TO OWNER OR ANY PARTY CLAIMING THROUGH OWNER, WHETHER BASED IN CONTRACT, NEGLIGENCE, TORT OR STRICT PRODUCTS LIABILITY OR ARISING FROM ANY CAUSE WHATSOEVER. Some states do not allow the exclusion of consequential damages, so the above exclusion may not apply to you. This warranty gives you specific rights; you may also have others that vary from state to state.