

NordicTrack[®] **C 2000**

Model No. NTL10841

Serial No. _____

Find the serial number in the location shown below. Write the serial number in the space above for reference.

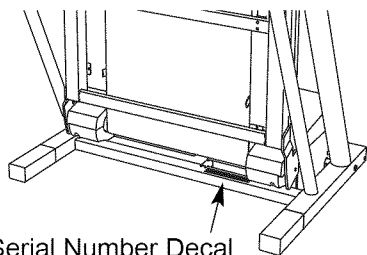

Serial Number Decal

USER'S MANUAL

QUESTIONS?

If you have questions, or if there are missing parts, we will guarantee complete satisfaction through direct assistance from our factory.

TO AVOID DELAYS, PLEASE CALL DIRECT TO OUR TOLL-FREE CUSTOMER HOT LINE. The trained technicians on our Customer Hot Line will provide immediate assistance, free of charge to you.

CUSTOMER HOT LINE:

1-888-825-2588

Mon.-Fri., 6 a.m.-6 p.m. MST

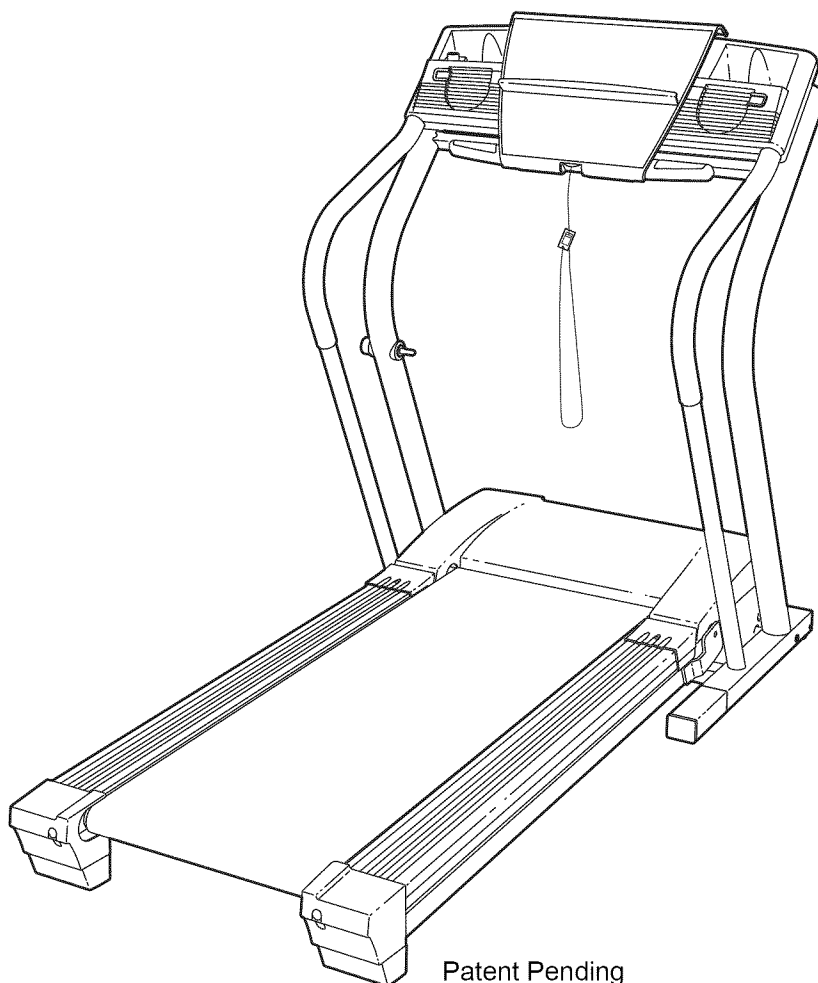

CAUTION

Read all precautions and instructions in this manual before using this equipment. Save this manual for future reference.



Visit our website at

www.nordictrack.com

*new products, prizes,
fitness tips, and much more!*



TABLE OF CONTENTS

IMPORTANT PRECAUTIONS	3
BEFORE YOU BEGIN	5
ASSEMBLY	6
OPERATION AND ADJUSTMENT	9
HOW TO FOLD AND MOVE THE TREADMILL	23
TROUBLESHOOTING	25
CONDITIONING GUIDELINES	27
PART LIST	30
ORDERING REPLACEMENT PARTS	31
LIMITED WARRANTY	Back Cover

Note: An EXPLODED DRAWING is attached in the center of this manual.

IMPORTANT PRECAUTIONS

▲ WARNING: To reduce the risk of burns, fire, electric shock, or injury to persons, read the following important precautions and information before operating the treadmill.

1. It is the responsibility of the owner to ensure that all users of this treadmill are adequately informed of all warnings and precautions.
2. Use the treadmill only as described.
3. Place the treadmill on a level surface, with at least eight feet of clearance behind it and two feet on each side. Do not place the treadmill on any surface that blocks air openings. To protect the floor or carpet from damage, place a mat under the treadmill.
4. Keep the treadmill indoors, away from moisture and dust. Do not put the treadmill in a garage or covered patio, or near water.
5. Do not operate the treadmill where aerosol products are used or where oxygen is being administered.
6. Keep children under the age of 12 and pets away from the treadmill at all times.
7. The treadmill should not be used by persons weighing more than 250 pounds.
8. Never allow more than one person on the treadmill at a time.
9. Wear appropriate exercise clothes when using the treadmill. Do not wear loose clothes that could become caught in the treadmill. Athletic support clothes are recommended for both men and women. *Always wear athletic shoes. Never use the treadmill with bare feet, wearing only stockings, or in sandals.*
10. When connecting the power cord (see page 9), plug the power cord into a surge suppressor (not included) and plug the surge suppressor into a grounded circuit capable of carrying 15 or more amps. No other appliance should be on the same circuit. Do not use an extension cord.
11. Use only a single-outlet surge suppressor that meets all of the specifications described on page 9. To purchase a surge suppressor, see your local NordicTrack dealer or call 1-800-806-3651 and order part number 146148.
12. Failure to use a properly functioning surge suppressor could result in damage to the control system of the treadmill. If the control system is damaged, the walking belt may change speed or stop unexpectedly, which may result in a fall and serious injury.
13. Keep the power cord and the surge suppressor away from heated surfaces.
14. Never move the walking belt while the power is turned off. Do not operate the treadmill if the power cord or plug is damaged, or if the treadmill is not working properly. (See **BEFORE YOU BEGIN** on page 5 if the treadmill is not working properly.)
15. Never start the treadmill while you are standing on the walking belt. Always hold the handrails while using the treadmill.
16. The treadmill is capable of high speeds. Adjust the speed in small increments to avoid sudden jumps in speed.
17. The pulse sensor is not a medical device. Various factors, including the user's movement, may affect the accuracy of heart rate readings. The pulse sensor is intended only as an exercise aid in determining heart rate trends in general.
18. Never leave the treadmill unattended while it is running. Always remove the key, unplug the power cord and move the reset/off circuit breaker to the off position when the treadmill is not in use. (See the drawing on page 5 for the location of the reset/off circuit breaker.)
19. Do not attempt to raise, lower, or move the treadmill until it is properly assembled. (See **ASSEMBLY** on page 6, and **HOW TO FOLD AND MOVE THE TREADMILL** on page 23.) You must be able to safely lift 45 pounds (20 kg) to raise, lower, or move the treadmill.
20. Do not change the incline of the treadmill by placing objects under the treadmill.
21. When folding or moving the treadmill, make sure that the storage latch is fully closed.

22. When using iFIT.com CDs and videos, an electronic “chirping” sound will alert you when the speed and/or incline of the treadmill is about to change. Always listen for the “chirp” and be prepared for speed and/or incline changes. In some instances, the speed and/or incline may change before the personal trainer describes the change.
23. When using iFIT.com CDs and videos, you can manually override the speed and incline settings by pressing the speed and incline buttons. However, when the next “chirp” is heard, the speed and/or incline will change to the next settings of the CD or video program.
24. Always remove iFIT.com CDs and videos from your CD player or VCR when you are not using them.
25. Inspect and properly tighten all parts of the treadmill regularly.

26. Never insert or drop any object into any opening.

27. **DANGER:** Always unplug the power cord immediately after use, before cleaning the treadmill, and before performing the maintenance and adjustment procedures described in this manual. Never remove the motor hood unless instructed to do so by an authorized service representative. Servicing other than the procedures in this manual should be performed by an authorized service representative only.

28. The treadmill is intended for in-home use only. Do not use the treadmill in any commercial, rental, or institutional setting.

29. Keep the aromatherapy bottle out of the reach of children. Essential oil may irritate skin and is not intended for internal or topical use.

⚠ WARNING: Before beginning this or any exercise program, consult your physician. This is especially important for persons over the age of 35 or persons with pre-existing health problems. Read all instructions before using. ICON assumes no responsibility for personal injury or property damage sustained by or through the use of this product.

SAVE THESE INSTRUCTIONS

The decals shown have been placed on your treadmill and on the aromatherapy bottle. If a decal is missing or illegible, please call our Customer Service Department, toll-free, to order a free replacement decal (see ORDERING REPLACEMENT PARTS on page 31). Apply the decal in the location shown. Note: The decals may not be shown at actual size.

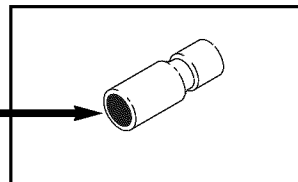
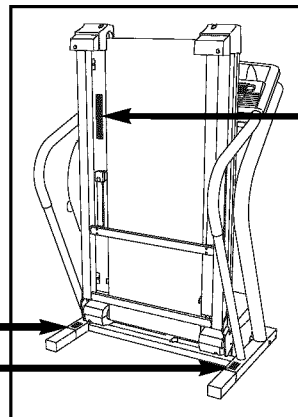

⚠ WARNING:
Protect yourself and others from risk of serious injury. Read the user's manual and

-  • Stand only on the side rails when starting or stopping treadmill
- Change speed in small increments
- Hold handrails to prevent falling and always wear the safety clip while operating treadmill
- Stop if you feel faint, dizzy, or short of breath
- Fully engage storage latch before treadmill is moved or stored
- Reduce incline to its lowest level before folding treadmill into storage position

-  • Never allow children on or around treadmill
- Remove key when not in use.

-  • Keep clothing, fingers and hair away from moving belt
- Never try to adjust or fix the belt while it is moving
- Always wear athletic shoes while operating treadmill

BEFORE YOU BEGIN

Thank you for selecting the revolutionary NordicTrack® C2000 treadmill. The C2000 treadmill combines advanced technology with innovative design to help you get the most from your exercise program in the convenience of your home. And when you're not exercising, the unique C2000 treadmill can be folded up, requiring less than half the floor space of other treadmills.

For your benefit, read this manual carefully before using the treadmill. If you have additional questions, please call our Customer Service Department toll-free

at 1-888-825-2588, Monday through Friday, 6 a.m. until 6 p.m. Mountain Time (excluding holidays). To help us assist you, please note the product model number and serial number before calling. The model number of the treadmill is NTL10841. The serial number can be found on a decal attached to the treadmill (see the front cover of this manual for the location).

Before reading further, please familiarize yourself with the parts that are labeled in the drawing below.

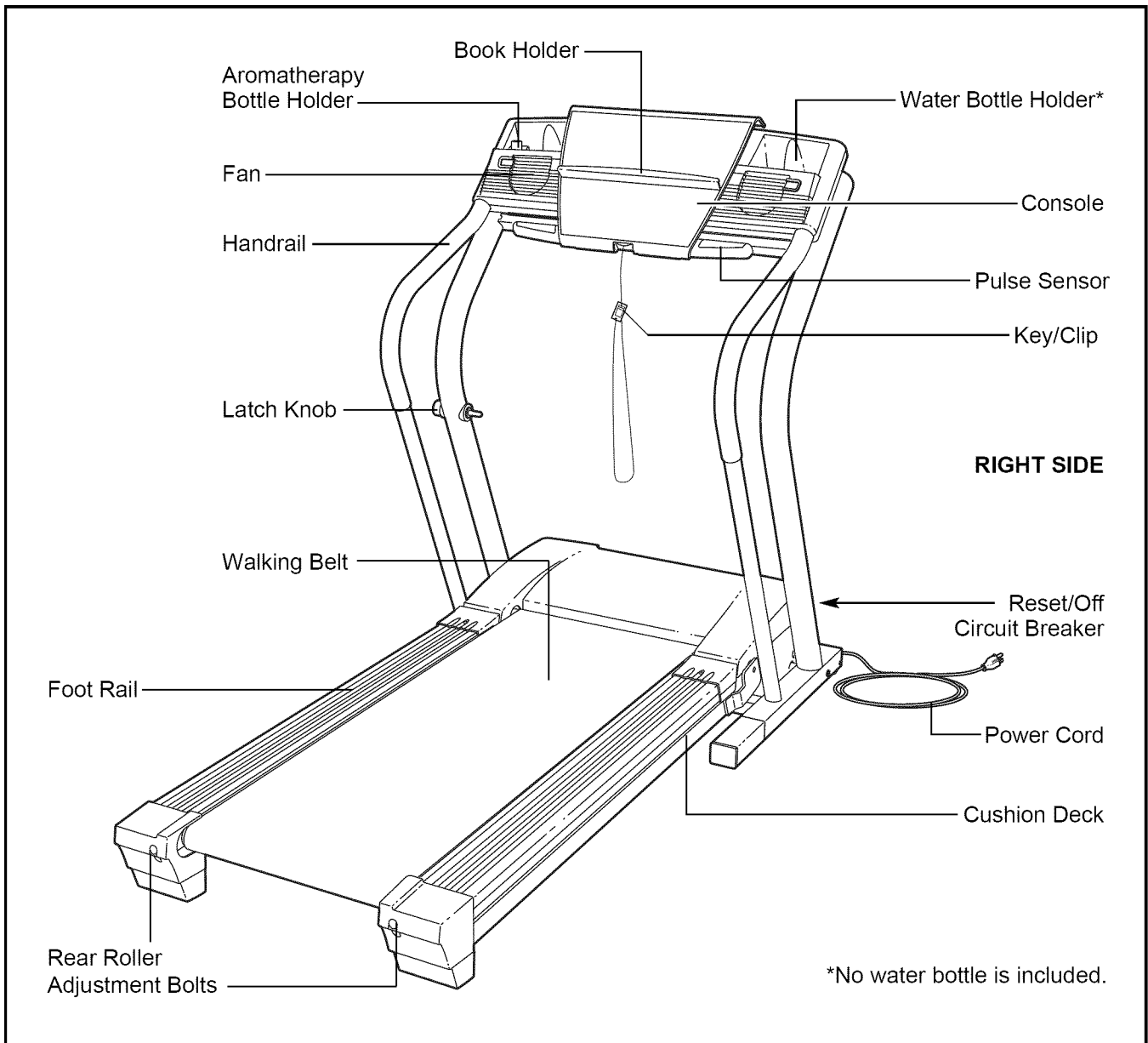

ASSEMBLY

Assembly requires two persons. Set the treadmill in a cleared area and remove all packing materials. Do not dispose of the packing materials until assembly is completed. **Assembly requires the included allen wrench and your own phillips screwdriver and wire cutters.**

Note: The underside of the treadmill walking belt is coated with high-performance lubricant. During shipping, a small amount of lubricant may be transferred to the top of the walking belt or the shipping carton. This is a normal condition and does not affect treadmill performance. If there is lubricant on top of the walking belt, simply wipe off the lubricant with a soft cloth and a mild, non-abrasive cleaner.

For help identifying the assembly hardware, see the hardware drawings below.

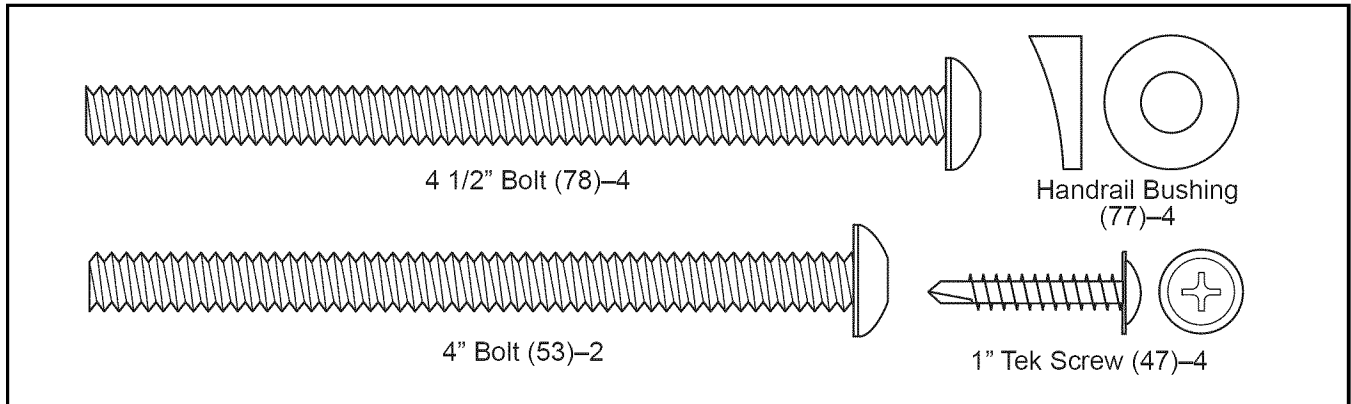

1. With the help of a second person, carefully raise the Uprights (69) to the position shown.

See the inset drawing. Insert one of the Extension Legs (102) into the treadmill as shown. Make sure that the Extension Leg is turned so the Base Pad (99) is beneath it. Note: It may be helpful to tip the Uprights (69) forward as you insert the Extension Leg.

Insert the other Extension Leg (not shown) in the same way.

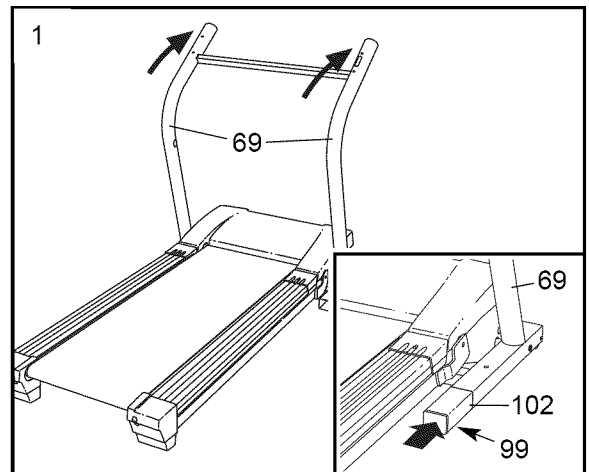

2. Press the Latch Knob Sleeve (70) into the left Upright (69).

Remove the Latch Knob (68) from the Latch Pin (74). Make sure that the Latch Pin Collar (72) and the Spring (71) are on the Latch Pin. Insert the Latch Pin into the Latch Knob Sleeve (70) and the left Upright (69). Press the Latch Knob Spacer (35) onto the other side of the left Upright, and then tighten the Latch Knob back onto the Latch Pin.

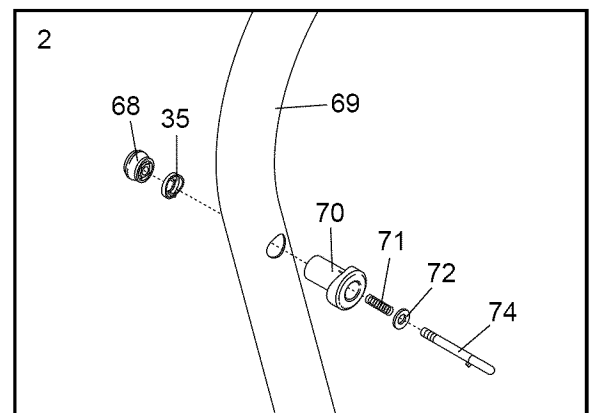

- Cut the rubber band holding the Upright Wire Harness (98). Have a second person hold the console assembly near the Uprights (69). Connect the Upright Wire Harness to the wires extending from the Console Base (81). **The connectors should slide together easily and snap into place. If they do not, turn one connector and try again.** Insert the connectors and the Upright Wire Harness into the right Upright, and then set the console assembly on the Uprights. **Be careful not to pinch the wires.**

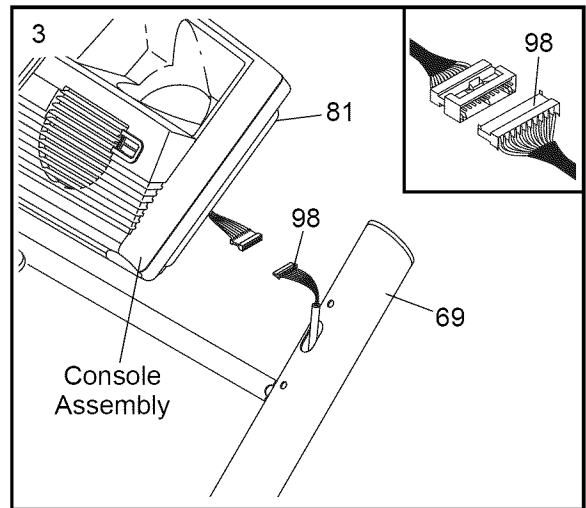

- Insert a Handrail (118) into the right side of the console assembly as shown; you may need to twist the Handrail as you insert it. Next, insert two 4 1/2" Bolts (78) with Handrail Bushings (77) into the right Upright (69) and the Handrail. **Be careful not to pinch the wires.** Make sure that the Handrail Bushings are flush against the right Upright, with the thicker sides facing the center of the treadmill, as shown in the inset drawing.

Next, lift the console assembly and the Handrail (118) slightly and align the 4 1/2" Bolts (78) with the holes in the Handrail. Thread the Bolts into the Upright (69) and the Handrail until the heads of the Bolts are against the Upright. **Do not tighten the Bolts yet.**

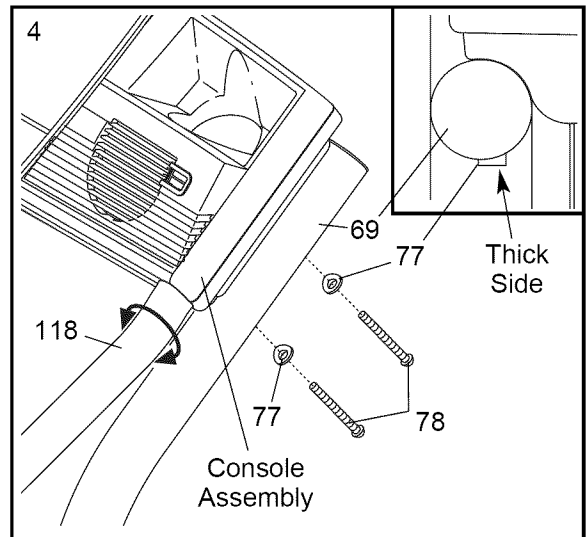

Attach the other Handrail (not shown) in the same way.
Note: There are no wires on the left side.

- With the help of a second person, carefully tip the Uprights (69) down to the position shown. **Make sure that the Extension Legs (102) remain in the Uprights.**

Attach each Extension Leg (102) with two 1" Tek Screws (47) and a Base Pad (99) as shown. (Note: Attach the lower Screw [without the Base Pad] first.) Next, align the lower ends of the Handrails (118) with the holes in the base of the Uprights (69). Attach each Handrail with a 4" Bolt (53) as shown. **Note: The Bolts must be at an angle that matches the angle of the Handrails as shown in the inset drawing.**

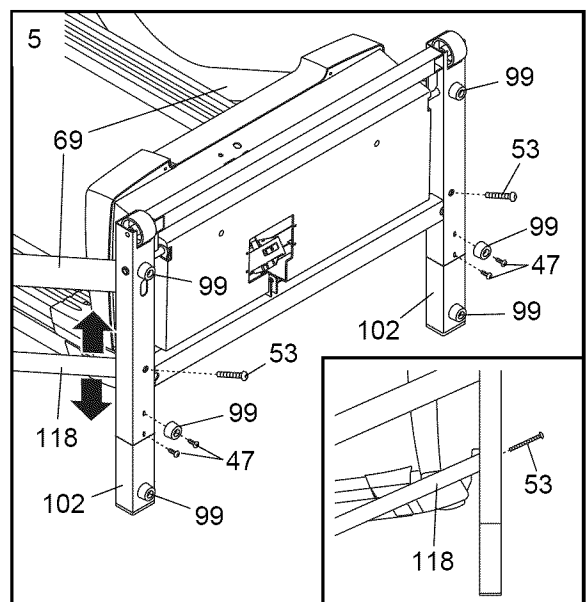

With the help of a second person, carefully tip the Uprights (69) back to the vertical position. See step 4. **Tighten the four 4 1/2" Bolts (78).**

Note: A replacement Base Pad (99) may be included. Use the Base Pad to replace any Base Pad that becomes worn.

- Make sure that all parts are properly tightened before you use the treadmill.** Keep the included allen wrench in a secure place. The allen wrench is used to adjust the walking belt (see page 26). **To protect the floor or carpet from damage, place a mat under the treadmill.**

If you purchase the optional chest pulse sensor (see page 22), follow the steps below to install the receiver and the short jumper wire included with the chest pulse sensor.

1. **Make sure that the power cord is unplugged.** Remove the indicated screws from the Console Back (88). **(Important: The screws may be different lengths; make sure to remember the original location of each screw.)** Next, remove the Console Back.

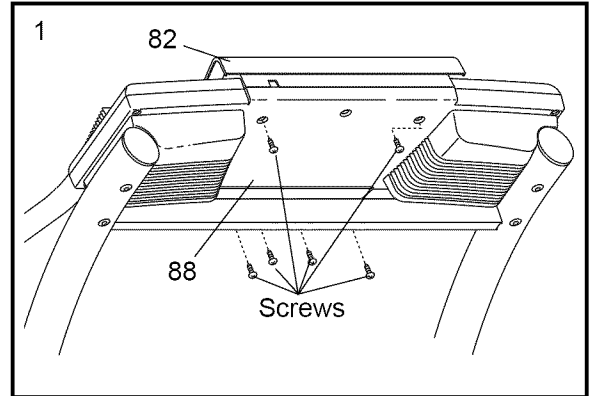

2. Peel the paper off the pad on the bottom of the receiver (A). **Turn the receiver so the small cylinder is on the side shown,** and press the receiver into the Console Base (81) in the indicated location.

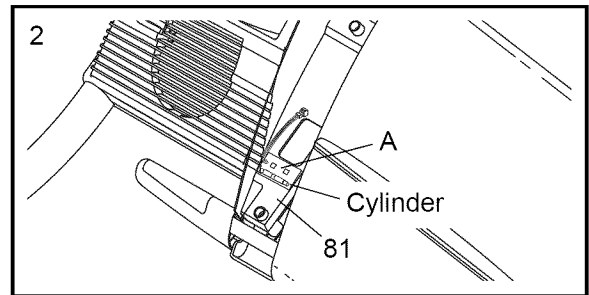

3. Connect the included short jumper wire (B) to the wire on the receiver (A). Connect the other end of the short jumper wire to the PLS2 jack on the underside of the Console (82). (Note: If there is already a wire in the PLS2 jack, unplug it.) Discard the other wires included with the receiver. Use the included wire tie to secure the wires, if needed.

Make sure that no wires are pinched. See step 1. Reattach the Console (82) with the screws. **Important: If the screws are not reattached in their original locations, the Console may be damaged.**

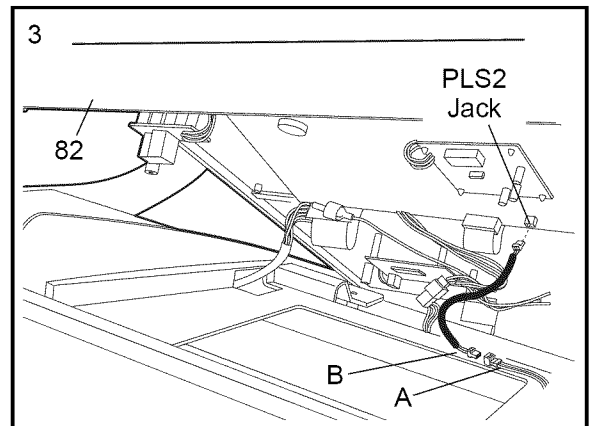

OPERATION AND ADJUSTMENT

THE PERFORMANT LUBE™ WALKING BELT

Your treadmill features a walking belt coated with PERFORMANT LUBE™, a high-performance lubricant. **IMPORTANT:** Never apply silicone spray or other substances to the walking belt or the walking platform. Such substances will deteriorate the walking belt and cause excessive wear.

HOW TO PLUG IN THE POWER CORD

⚠ DANGER: Improper connection of the equipment-grounding conductor can result in an increased risk of electric shock. Check with a qualified electrician or serviceman if you are in doubt as to whether the product is properly grounded. Do not modify the plug provided with the product—if it will not fit the outlet, have a proper outlet installed by a qualified electrician.

Your treadmill, like any other type of sophisticated electronic equipment, can be seriously damaged by sudden voltage changes in your home's power. Voltage surges, spikes, and noise interference can result from weather conditions or from other appliances being turned on or off. **To decrease the possibility of your treadmill being damaged, always use a surge suppressor with your treadmill (see drawing 1 at the right).** To purchase a surge suppressor, see your local NordicTrack dealer or call 1-800-806-3651 and order part number 146148.

Use only a single-outlet surge suppressor that is UL 1449 listed as a transient voltage surge suppressor (TVSS). The surge suppressor must have a UL suppressed voltage rating of 400 volts or less and a minimum surge dissipation of 450 joules. The surge suppressor must be electrically rated for 120 volts AC and 15 amps. There must be a monitoring light on the surge suppressor to indicate whether it is functioning properly. Failure to use a properly functioning surge suppressor could result in damage to the control system of the treadmill. If the control system is damaged, the walking belt may change speed or stop unexpectedly, which may result in a fall and serious injury.

This product must be grounded. If it should malfunction or break down, grounding provides a path of least resistance for electric current to reduce the risk of electric shock. This product is equipped with a cord having

an equipment-grounding conductor and a grounding plug. **Plug the power cord into a surge suppressor, and plug the surge suppressor into an appropriate outlet that is properly installed and grounded in accordance with all local codes and ordinances. Important: The treadmill is not compatible with GFCI-equipped outlets.**

This product is for use on a nominal 120-volt circuit, and has a grounding plug that looks like the plug illustrated in drawing 1 below. A temporary adapter that looks like the adapter illustrated in drawing 2 may be used to connect the surge suppressor to a 2-pole receptacle as shown in drawing 2 if a properly grounded outlet is not available.

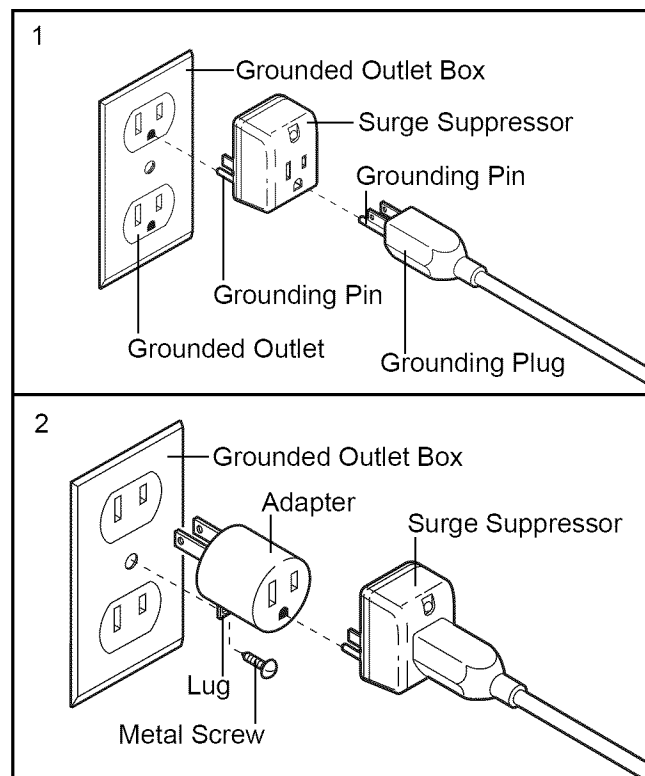

The temporary adapter should be used only until a properly grounded outlet (drawing 1) can be installed by a qualified electrician.

The green-colored rigid ear, lug, or the like extending from the adapter must be connected to a permanent ground such as a properly grounded outlet box cover. Whenever the adapter is used it must be held in place by a metal screw. **Some 2-pole receptacle outlet box covers are not grounded. Contact a qualified electrician to determine if the outlet box cover is grounded before using an adapter.**

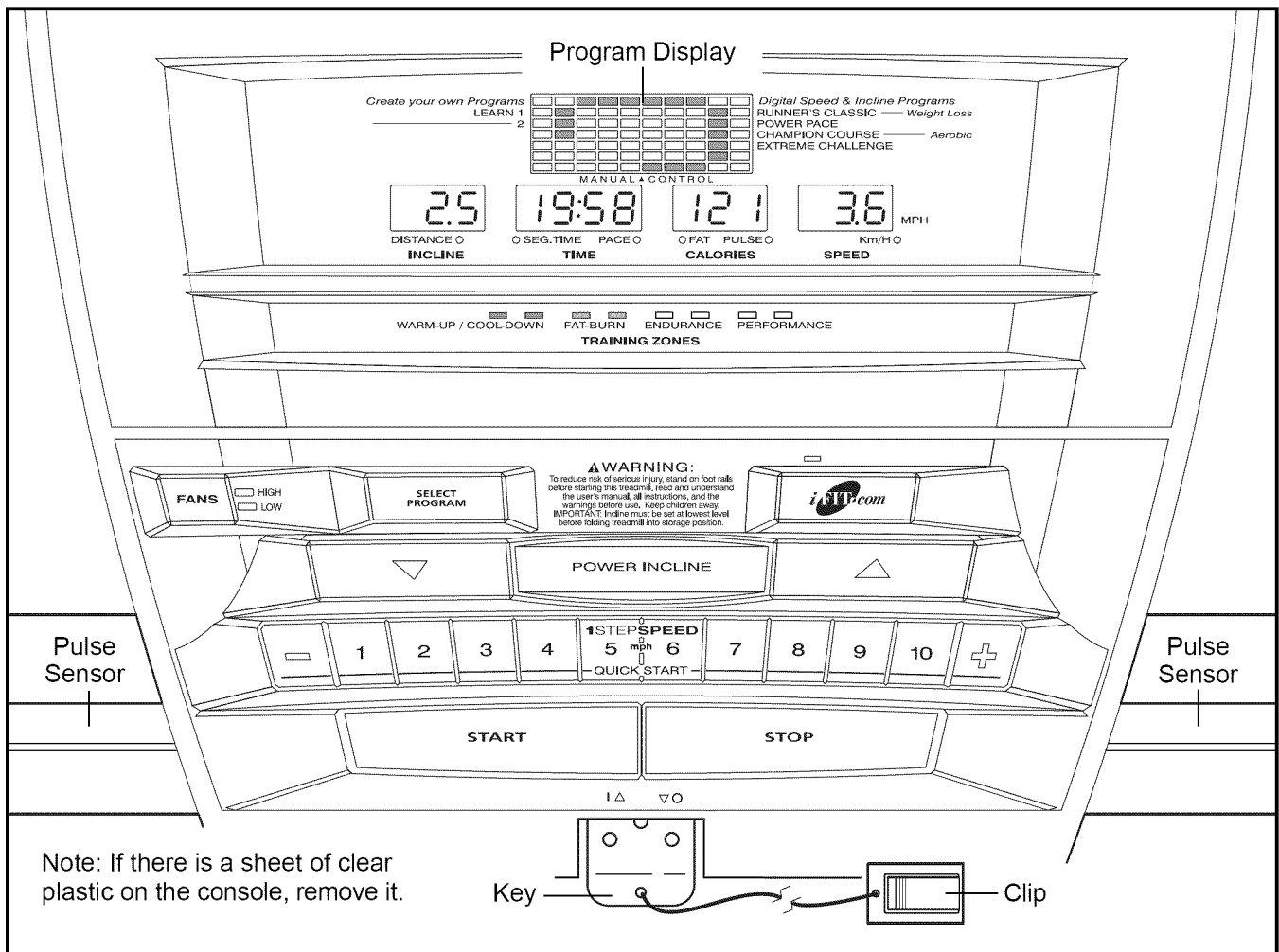

FEATURES OF THE CONSOLE

The advanced console offers an impressive array of features to help you get the most from your exercise. When the manual mode of the console is selected, the speed and incline of the treadmill can be changed with the touch of a button. As you exercise, the console will provide continuous exercise feedback. You can even measure your heart rate using the built-in pulse sensor. Note: For information about an optional chest pulse sensor, see page 22.

Four preset workout programs are also offered. Each program automatically controls the speed and incline of the treadmill as it guides you through an effective workout. You can even create your own custom workout programs and store them in memory for future use.

The console also features new iFIT.com interactive technology. Having iFIT.com technology is like having a personal trainer in your home. Using the included audio cable, you can connect the treadmill to your home

stereo, portable stereo, computer, or VCR and play special iFIT.com CD and video programs (iFIT.com CDs and videocassettes are available separately). iFIT.com CD and video programs automatically control the speed and incline of the treadmill as a personal trainer coaches you through every step of your workout. High-energy music provides added motivation. **To purchase iFIT.com CDs or videocassettes, call toll-free 1-800-735-0768.**

With the treadmill connected to your computer, you can also go to our Web site at www.iFIT.com and access programs directly from the internet. Additional options are soon to be available. **See www.iFIT.com for more information.**

To use the manual mode of the console, follow the steps beginning on page 11. **To use a preset program**, see page 13. **To create and use a custom program**, see pages 15 and 16. **To use an iFIT.com CD or video program**, see page 19. **To use an iFIT.com program directly from our Web site**, see page 21.

CAUTION: Before operating the console, read the following precautions.

- Do not stand on the walking belt when turning on the power.
- Always wear the clip (see page 10) while operating the treadmill.
- Adjust the speed in small increments to avoid sudden jumps in speed.
- The pulse sensor is not a medical device. Various factors, including the user's movement, may affect the accuracy of heart rate readings. The pulse sensor is intended only as an exercise aid in determining heart rate trends in general.
- To reduce the possibility of electric shock, keep the console dry. Avoid spilling liquids on the console and place only a sealed water bottle in the water bottle holder.

HOW TO TURN ON THE POWER

1 Plug in the power cord.

See page 9.

2 Move the reset/off circuit breaker to the reset position.

Locate the reset/off circuit breaker near the power cord. Make sure that the circuit breaker is in the reset position.

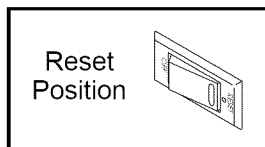

3 Attach the clip to the waistband of your clothes.

Stand on the foot rails of the treadmill. Find the clip attached to the key (see the drawing on page 10), and slide the clip onto the waistband of your clothes. Next, insert the key into the console. **Test the clip by carefully taking a few steps backward until the key is pulled from the console. If the key is not pulled from the console, adjust the position of the clip as needed.** Then, remove the key from the console.

HOW TO USE THE MANUAL MODE

1 Insert the key fully into the console.

See HOW TO TURN ON THE POWER at the left.

2 Select the manual mode.

When the key is inserted, the manual mode will be selected. If a program has been selected, reselect the manual mode by pressing the Select Program button repeatedly until the track appears in the program display but the indicator above the iFIT.com button is not lit.

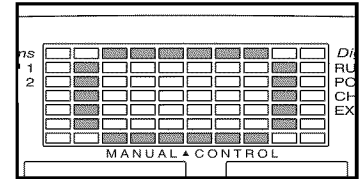

3 Start the walking belt.

To start the walking belt, press the Start button, the Speed + button, or one of the ten Quick Start buttons.

If the Start button or the Speed + button is pressed, the walking belt will begin to move at 1 mph. As you exercise, change the speed of the walking belt as desired by pressing the Speed + and – buttons. Each time a button is pressed, the speed setting will change by 0.1 mph; if a button is held down, the speed setting will change in increments of 0.5 mph.

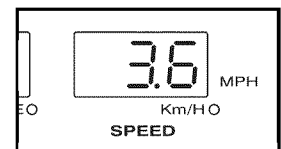

If one of the Quick Start buttons is pressed, the walking belt will gradually increase in speed until it reaches the selected speed setting. **Note: The console can display speed and distance in either miles or kilometers. For simplicity, all instructions in this section refer to miles.**

To stop the walking belt, press the Stop button. The time will begin to flash in the Time/Pace display. To restart the walking belt, press the Start button, the Speed + button, or one of the ten Quick Start buttons.

Note: During the first few minutes that the treadmill is used, observe the alignment of the walking belt, and align it if necessary (see page 26).

4 Change the incline of the treadmill as desired.

To change the incline of the treadmill, press the Incline buttons. Each time a button is pressed, the incline will change by 0.5%. Note:

After the buttons are pressed, it may take a moment for the treadmill to reach the selected incline setting.

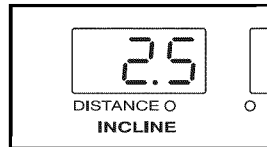

5 Follow your progress with the displays.

The program display—When the manual mode or the iFIT.com mode is selected, the program display will show a track representing 1/4 mile. As you exercise, the indicators around the track will light in succession until the entire track is lit. The track will then darken and the indicators will again begin to light in succession.

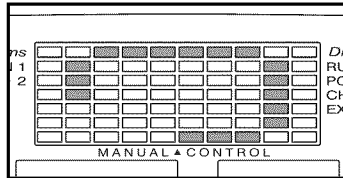

The Training Zone display—As you exercise, the Training Zone display will show the approximate intensity level of your exercise.

For example, if three or four indicators are lit, your intensity level is ideal for fat burning.

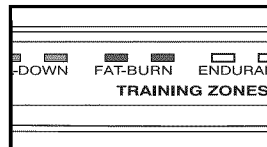

Incline/Distance display—This display shows the incline level of the treadmill and the distance that you have walked or run. The display will change from one number to the other every few seconds, as shown by the indicator below the display. Note: Each time the incline level changes, the display will show the incline level.

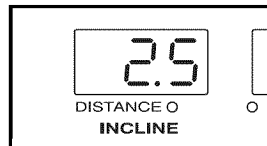

Time/Pace display—When the manual mode or the iFIT.com mode is selected, this display will show the elapsed time and your current pace (pace is measured in *minutes per mile*). When a preset program or a custom program is selected, the display will show the time remaining in the program, the time remaining in the current



segment of the program, and your current pace. The display will change from one number to the next every few seconds, as shown by the indicators below the display.

Calories/Pulse display—When the handgrip pulse sensor is not being used, this display will show the approximate numbers of calories and fat calories you have burned (see FAT BURNING on page 27). When the handgrip pulse sensor or the optional chest pulse sensor is used, the display will also show your heart rate (see step 6 below).

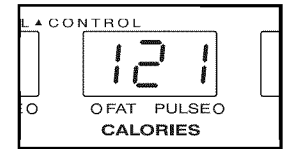

Speed display—This display shows the speed of the walking belt.

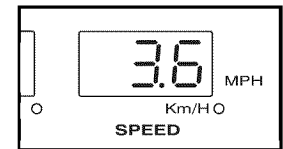

Note: When the Km/H indicator below the Speed display is lit, the console will display speed and distance in kilometers; when the indicator is not lit, the console will display speed and distance in miles. To change the unit of measurement, first hold down the Stop button while inserting the key into the console. An "E" for English miles or an "M" for metric kilometers will appear in the Speed display. Press the Speed + button to change the unit of measurement. When the desired unit of measurement is selected, remove the key and then reinsert it.

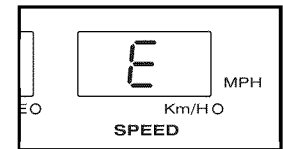

To reset the displays, press the Stop button, remove the key, and then reinsert the key.

6 Measure your heart rate if desired.

To measure your heart rate, **stand on the foot rails** and place your hands on the metal contacts on the handrail. Your palms must be resting on the upper contacts, and your fingers must be touching the lower contacts—**avoid**

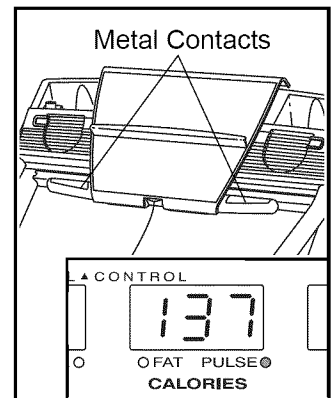

moving your hands. When your pulse is detected, the Pulse indicator will light, one or two dashes (—) will appear in the Calories/Pulse display, and then your heart rate will be shown. **For the most accurate heart rate reading, continue to hold the contacts for about 15 seconds.**

7 Turn on the fans if desired.

To turn on the fans at low speed, press the Fans button. To turn on the fans at high speed, press the Fans button a second time. To turn off the fans, press the Fans buttons a third time. Note: Any time that the walking belt is stopped for a few minutes, the fans will automatically turn off.

8 When you are finished exercising, stop the walking belt and remove the key.

Step onto the foot rails, press the Stop button, and adjust the incline of the treadmill to the lowest level. **The incline must be at the lowest level when the treadmill is raised to the storage position or the treadmill will be damaged.** Next, remove the key from the console and put it in a secure place. **Note: If the displays and indicators on the console remain lit after the key is removed, the console is in the “demo” mode. See page 22 and turn off the demo mode.**

When you are finished using the treadmill, switch the reset/off circuit breaker to the off position and unplug the power cord.

HOW TO USE PRESET PROGRAMS

1 Insert the key fully into the console.

See HOW TO TURN ON THE POWER on page 11.

2 Select one of the four preset programs.

When the key is inserted, the manual mode will be selected. To select a preset program, press the Select Program button repeatedly until the Runner's Classic, Power Pace, Champion Course, or Extreme Challenge indicator lights.

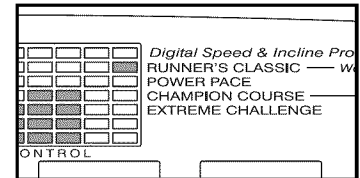

For about six seconds after a program is selected, the Incline/Distance display will flash the maximum incline setting for the program, and the Speed display will flash the maximum speed setting for the program. The Time/Pace display will show how long the program will last. The program display will show the first five speed settings of the program.

3 Press the Start button or the Speed + button to start the program.

A moment after the button is pressed, the treadmill will automatically adjust to the first speed and incline settings for the program. Hold the handrails and begin walking.

Each program is divided into several time segments of different lengths. (The Time/Pace display will show both the time remaining in the program and the time remaining in the current segment.) One speed setting and one incline setting are programmed for each segment. (The same speed setting and/or incline setting may be programmed for two or more consecutive segments.) The speed setting for the first segment will be shown in the flashing Current Segment column of the program display. (The incline settings are not shown in the program display.) The speed settings for the next seven segments will be shown in the columns to the right.

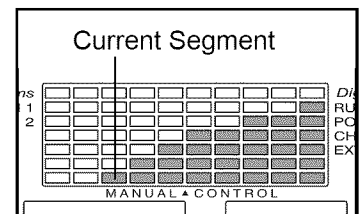

When only three seconds remain in the first segment of the program, both the Current Segment column and the column to the right will flash and a series of tones will sound. In addition, if the speed and/or incline of the treadmill is about to change, the Speed display and/or the Incline/Distance display will flash to alert you. When the first segment is completed, *all speed settings will move one column to the left*. The speed setting for the second segment will then be shown in the flashing Current Segment column and the treadmill will automatically adjust to the speed and incline settings for the second segment. Note: If all of the indicators in the Current Segment column are lit after the speed settings have moved to the left, *the speed settings will move downward* so that only the highest indicators appear in the program display. If some of the indicators in the Current Segment column are not lit when the speed settings move to the left again, the speed settings will move back up.

The program will continue in this way until the speed setting for the last segment is shown in the Current Segment column and the last segment ends. The walking belt will then slow to a stop.

If the speed or incline setting is too high or too low at any time during the program, you can manually override the setting by pressing the Speed or Incline buttons. Every few times a Speed button is pressed, an additional indicator will light or darken in the Current Segment column. (If any of the columns to the right of the Current Segment column have the same number of lit indicators as the Current Segment column, an additional indicator may light or darken in those columns as well.)

Note: If you manually override the speed or incline setting, when the next segment begins, the treadmill will automatically adjust to the speed and incline settings for the next segment.

To stop the program temporarily, press the Stop button. The Time/Pace display will begin to flash. To restart the program, press the Start button or the Speed + button. The walking belt will begin to move at 1 mph. When the next segment of the program begins, the treadmill will automatically adjust to the speed and incline settings for the next segment. To end the program, press the Stop button, remove the key, and then reinsert the key.

4 Follow your progress with the displays.

See step 5 on page 12.

5 Measure your heart rate if desired.

See step 6 on page 12.

6 Turn on the fans if desired.

See step 7 on page 13.

7 When you are finished exercising, remove the key.

Step onto the foot rails and make sure that the incline of the treadmill is at the lowest level. **The incline must be at the lowest level when the treadmill is raised to the storage position.** Next, remove the key from the console and put it in a secure place. **Note: If the displays and indicators on the console remain lit after the key is removed, the console is in the “demo” mode. See page 22 and turn off the demo mode.**

When you are finished using the treadmill, switch the reset/off circuit breaker to the off position and unplug the power cord.

HOW TO CREATE CUSTOM PROGRAMS

1 Insert the key fully into the console.

See HOW TO TURN ON THE POWER on page 11.

2 Select one of the custom programs.

When the key is inserted, the manual mode will be selected. To select a custom program, press the Select

Program button repeatedly until the Learn 1 or Learn 2 indicator lights.

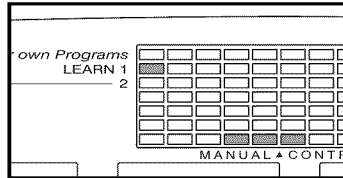

Note: If the custom program has not yet been defined, three columns of indicators will be lit in the program display. If more than three columns of indicators are lit, see HOW TO USE CUSTOM PROGRAMS on page 16.

3 Press the Start button or the Speed + button and program the desired speed and incline settings.

A moment after the button is pressed, the walking belt will begin to move. Hold the handrails and begin walking.

See the program display. Each custom program is divided into one-minute segments. One speed setting and one incline setting can be programmed for each segment. The speed setting for the first segment will be shown in the flashing Current Segment column of the program display. (The incline settings are not shown in the program display.) To program a speed

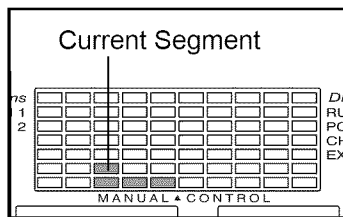

setting and an incline setting for the first segment, simply adjust the speed and incline of the treadmill as desired by pressing the Speed and Incline buttons. Every few times a Speed button is pressed, an additional indicator will light or darken in the Current Segment column.

During the last three seconds of the first segment, both the Current Segment column and the column to the right will flash, a series of tones will sound, and the Speed display and the Incline/Distance display will flash. When the first segment ends, the current speed setting and the current incline setting will be saved in memory, and *all speed settings in the program display will move one column to the left*. The speed setting for the second segment will then be shown in the flashing Current Segment column. Program a speed setting and an incline setting for the second segment as described above.

Continue programming speed and incline settings for as many segments as desired; custom programs can have up to forty segments. When you are finished with your workout, press the Stop button twice. The speed and incline settings that you have programmed and the number of segments that you have programmed will then be saved in memory.

4 Follow your progress with the displays.

See step 5 on page 12.

5 Measure your heart rate if desired.

See step 6 on page 12.

6 Turn on the fans if desired.

See step 7 on page 13.

7 When you are finished exercising, remove the key.

See step 7 on page 14.

HOW TO USE CUSTOM PROGRAMS

1 Insert the key fully into the console.

See HOW TO TURN ON THE POWER on page 11.

2 Select one of the custom programs.

When the key is inserted, the manual mode will be selected. To select a custom program, press the Select

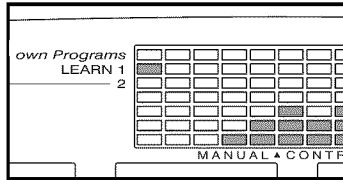

Program button repeatedly until the Learn 1 or Learn 2 indicator lights.

For about six seconds after a program is selected, the Incline/Distance display will flash the maximum incline setting for the program, and the Speed display will flash the maximum speed setting for the program. The Time/Pace display will show how long the program will last. **Note: If only three columns of indicators are lit in the program display, see HOW TO CREATE A CUSTOM PROGRAM on page 15.**

3 Press the Start button or the Speed + button to start the program.

A moment after the button is pressed, the treadmill will automatically adjust to the first speed and incline settings that you programmed previously. Hold the handrails and begin walking.

Each program is divided into several one-minute segments. One speed setting and one incline setting are programmed for each segment. The speed setting for the first segment is shown in the flashing Current Segment column of the program display. (The incline settings are not shown in the program display.) The speed settings for the next seven segments will be shown in the columns to the right.

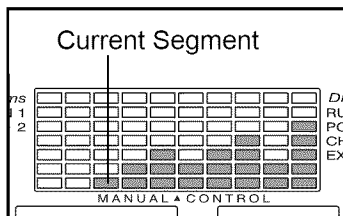

When only three seconds remain in the first segment of the program, both the Current Segment

column and the column to the right will flash, a series of tones will sound, the Speed display and the Incline/Distance display will flash, and *all speed settings will move one column to the left*. The speed setting for the second segment will then be shown in the flashing Current Segment column and the treadmill will automatically adjust to the second speed and incline settings that you programmed previously.

The program will continue until the speed setting for the last segment is shown in the Current Segment column and the last segment ends. The walking belt will then slow to a stop.

If desired, you can redefine the program while using it. **To change the speed or incline setting for the current segment**, simply press the Speed or Incline buttons. When the current segment ends, the new setting will be saved in memory. **To increase the length of the program**, first wait until the program is completed. Then, press the Start button and program speed and incline settings for as many additional segments as desired. When you have added as many segments as desired, press the Stop button twice. **To decrease the length of the program**, press the Stop button twice at any time before the program is completed.

To stop the program at any time, press the Stop button. The time will begin to flash in the Time/Pace display. To restart the program, press the Start button or the Speed + button. The walking belt will begin to move at 1 mph. When the next segment of the program begins, the treadmill will automatically adjust to the speed and incline settings for the next segment.

4 Follow your progress with the displays.

See step 5 on page 12.

5 Measure your heart rate if desired.

See step 6 on page 12.

6 Turn on the fan if desired.

See step 7 on page 13.

7 When you are finished exercising, remove the key from the console.

See step 7 on page 14.

HOW TO CONNECT THE TREADMILL TO YOUR CD PLAYER, VCR, OR COMPUTER

To use **iFIT.com CDs**, the treadmill must be connected to your portable CD player, portable stereo, home stereo, or computer with CD player. See pages 17 and 18 for connecting instructions. To use **iFIT.com videocassettes**, the treadmill must be connected to your VCR. See page 19 for connecting instructions. To use **iFIT.com programs directly from our Web site**, the treadmill must be connected to your home computer. See page 18 for connecting instructions.

HOW TO CONNECT YOUR PORTABLE CD PLAYER

Note: If your CD player has separate **LINE OUT** and **PHONES** jacks, see instruction A below. If your CD player has only one jack, see instruction B.

- A. Plug one end of the audio cable into the jack on the front of the treadmill near the power cord. Plug the other end of the cable into the **LINE OUT** jack on your CD player. Plug your headphones into the **PHONES** jack.

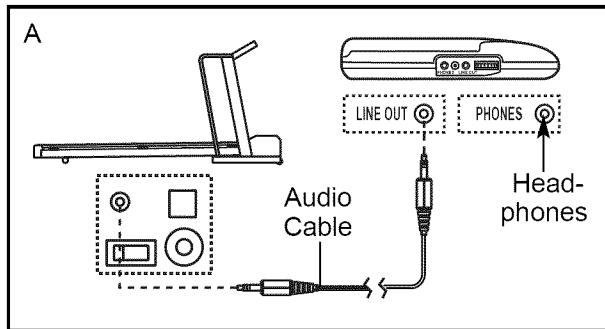

- B. Plug one end of the audio cable into the jack on the front of the treadmill near the power cord. Plug the other end of the cable into a 3.5mm Y-adaptor (available at electronics stores). Plug the Y-adaptor into the **PHONES** jack on your CD player. Plug your headphones into the other side of the Y-adaptor.

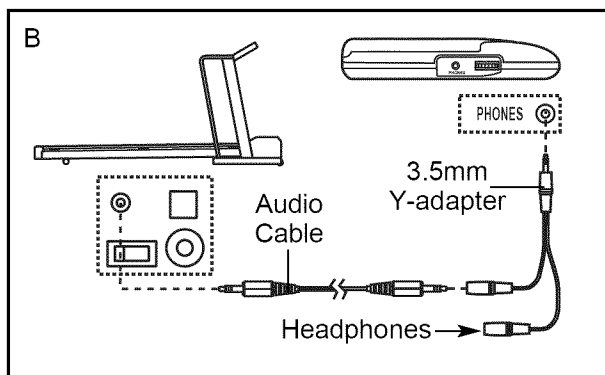

HOW TO CONNECT YOUR PORTABLE STEREO

Note: If your stereo has an **RCA-type AUDIO OUT** jack, see instruction A below. If your stereo has a **3.5mm LINE OUT** jack, see instruction B. If your stereo has only a **PHONES** jack, see instruction C.

- A. Plug one end of the audio cable into the jack on the front of the treadmill near the power cord. Plug the other end of the cable into the included adaptor. Plug the adaptor into an **AUDIO OUT** jack on your stereo.

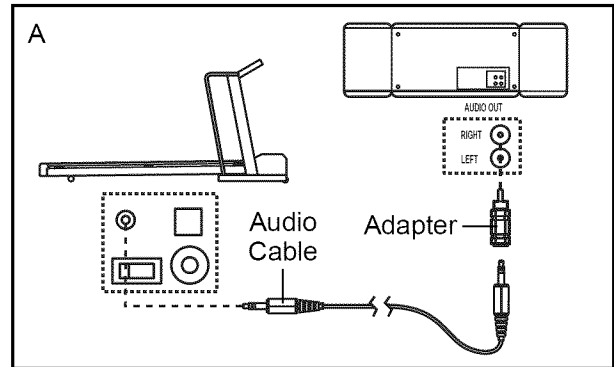

- B. Plug one end of the audio cable into the jack on the front of the treadmill near the power cord. Plug the other end of the cable into the **LINE OUT** jack on your stereo.

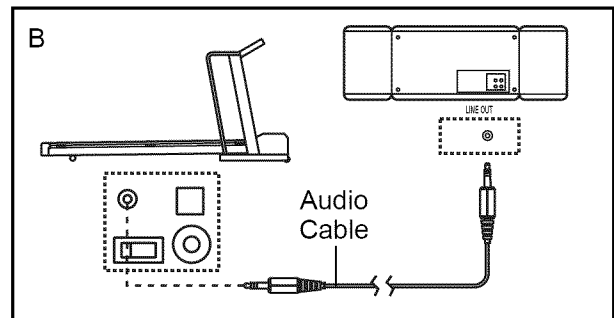

- C. Plug one end of the audio cable into the jack on the front of the treadmill near the power cord. Plug the other end of the cable into a 3.5mm Y-adaptor (available at electronics stores). Plug the Y-adaptor into the **PHONES** jack on your stereo. Plug your headphones into the other side of the Y-adaptor.

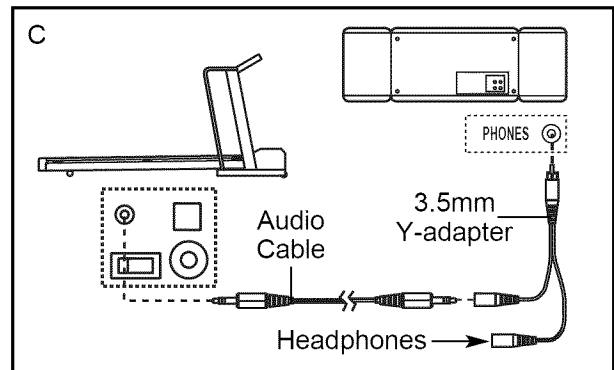

HOW TO CONNECT YOUR HOME STEREO

Note: If your stereo has an unused **LINE OUT** jack, see instruction **A** below. If the **LINE OUT** jack is being used, see instruction **B**.

- A. Plug one end of the audio cable into the jack on the front of the treadmill near the power cord. Plug the other end of the cable into the included adapter. Plug the adapter into the **LINE OUT** jack on your stereo.

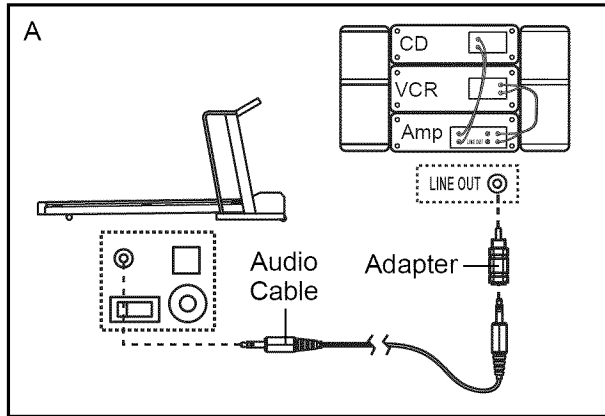

- B. Plug one end of the audio cable into the jack on the front of the treadmill near the power cord. Plug the other end of the cable into the included adapter. Plug the adapter into an **RCA Y-adapter** (available at electronics stores). Next, remove the wire that is currently plugged into the **LINE OUT** jack on your stereo and plug the wire into the unused side of the **RCA Y-adapter**. Plug the **RCA Y-adapter** into the **LINE OUT** jack on your stereo.

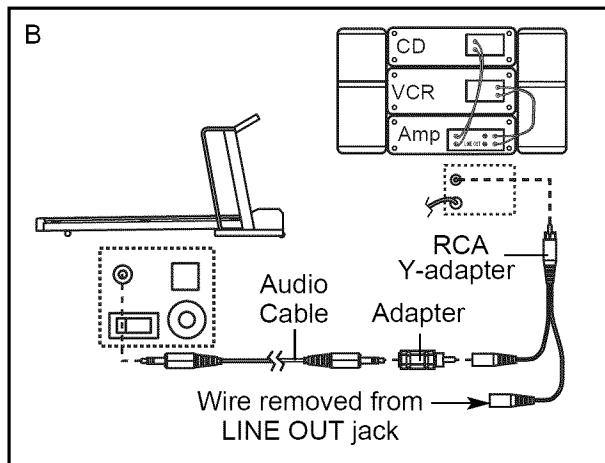

HOW TO CONNECT YOUR COMPUTER

Note: If your computer has a **3.5mm LINE OUT** jack, see instruction **A**. If your computer has only a **PHONES** jack, see instruction **B**.

- A. Plug one end of the audio cable into the jack on the front of the treadmill near the power cord. Plug the other end of the cable into the **LINE OUT** jack on your computer.

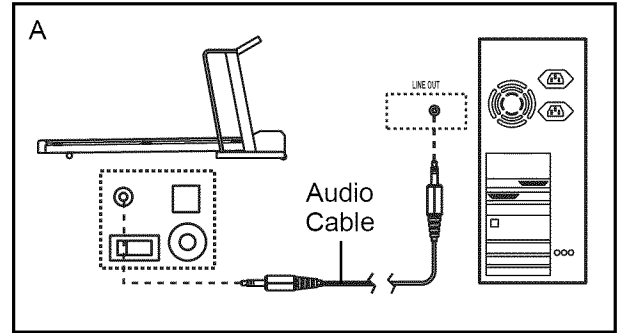

- B. Plug one end of the audio cable into the jack on the front of the treadmill near the power cord. Plug the other end of the cable into a **3.5mm Y-adapter** (available at electronics stores). Plug the **Y-adapter** into the **PHONES** jack on your computer. Plug your headphones or speakers into the other side of the **Y-adapter**.

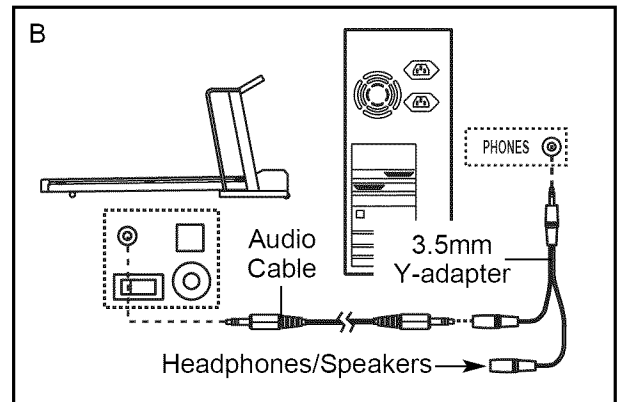

HOW TO CONNECT YOUR VCR

Note: If your VCR has an unused AUDIO OUT jack, see instruction A below. If the AUDIO OUT jack is being used, see instruction B. If you have a TV with a built-in VCR, see instruction B. If your VCR is connected to your home stereo, see **HOW TO CONNECT YOUR HOME STEREO** on page 18.

- A. Plug one end of the audio cable into the jack on the front of the treadmill near the power cord. Plug the other end of the cable into the included adapter. Plug the adapter into the AUDIO OUT jack on your VCR.

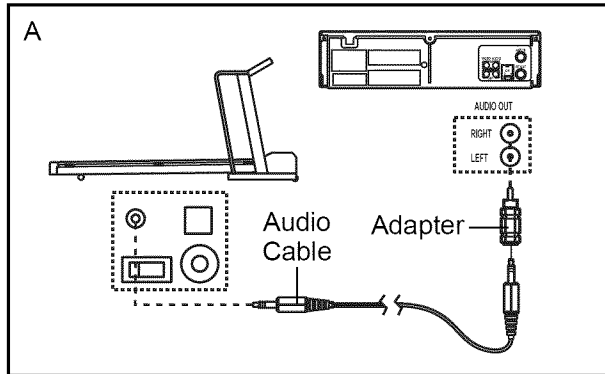

- B. Plug one end of the audio cable into the jack on the front of the treadmill near the power cord. Plug the other end of the cable into the included adapter. Plug the adapter into an RCA Y-adapter (available at electronics stores). Next, remove the wire that is currently plugged into the AUDIO OUT jack on your VCR and plug the wire into the unused side of the RCA Y-adapter. Plug the RCA Y-adapter into the AUDIO OUT jack on your VCR.

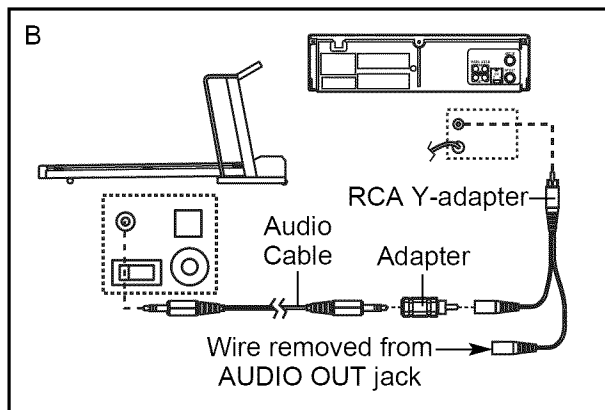

HOW TO USE iFIT.COM CD AND VIDEO PROGRAMS

To use iFIT.com CDs or videocassettes, the treadmill must be connected to your portable CD player, portable stereo, home stereo, computer with CD player, or VCR. See **HOW TO CONNECT THE TREADMILL TO YOUR CD PLAYER, VCR, OR COMPUTER** on pages 17 to 19. **Note:** To purchase iFIT.com CDs or videocassettes, call toll-free 1-800-735-0768.

Follow the steps below to use an iFIT.com CD or video program.

1 Insert the key fully into the console.

See **HOW TO TURN ON THE POWER** on page 11.

2 Select the iFIT.com mode.

When the key is inserted, the manual mode will be selected. To use an iFIT.com CD or video program, press the iFIT.com button or press the Select Program button repeatedly until the indicator above the iFIT.com button lights.

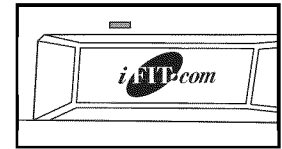

3 Insert the iFIT.com CD or videocassette.

If you are using an iFIT.com CD, insert the CD into your CD player. If you are using an iFIT.com videocassette, insert the videocassette into your VCR.

4 Press the PLAY button on your CD player or VCR.

A moment after the button is pressed, your personal trainer will begin guiding you through your workout. Simply follow your personal trainer's instructions. **Note:** If the Time/Pace display is flashing, press the Start button or the Speed + button on the console. The treadmill will not respond to a CD or video program when the Time/Pace display is flashing.

During the CD or video program, an electronic "chirping" sound will alert you when the speed and/or incline of the treadmill is about to change. **CAUTION: Always listen for the "chirp" and be prepared for speed and/or incline changes. In some instances, the speed and/or incline may change before the personal trainer describes the change.**

If the speed or incline settings are too high or too low, you can manually override the settings at any time by pressing the Speed or Incline buttons on the console. However, **when the next “chirp” is heard, the speed and/or incline will change to the next settings of the CD or video program.**

To stop the walking belt at any time, press the Stop button on the console. The Time/Pace display will begin to flash. To restart the program, press the Start button or the Speed + button. After a moment, the walking belt will begin to move at 1.0 mph. **When the next “chirp” is heard, the speed and incline will change to the next settings of the CD or video program.** When the CD or video program is completed, the walking belt will stop and the Time/Pace display will begin to flash. Note: To use another CD or video program, press the Stop button or remove the key and go to step 1 on page 19.

Note: If the speed or incline of the treadmill does not change when a “chirp” is heard:

- **Make sure that the iFIT.com indicator is lit and that the Time/Pace display is not flashing. If the Time/Pace display is flashing, press the Start button or the Speed + button on the console.**
- **Adjust the volume of your CD player or VCR. If the volume is too high or too low, the console may not detect the program signals.**

- **Make sure that the audio cable is properly connected, that it is fully plugged in, and that it is not wrapped around a power cord.**
- **If you are using your portable CD player and the CD skips, set the CD player on the floor or another flat surface instead of on the console.**
- **See the instructions near the bottom of page 26.**

5 Follow your progress with the displays.

See step 5 on page 12.

6 Measure your heart rate if desired.

See step 6 on page 12.

7 Turn on the fans if desired.

See step 7 on page 13.

8 When the program has ended, remove the key.

See step 7 on page 14.

CAUTION: Always remove iFIT.com CDs and videocassettes from your CD player or VCR when you are finished using them.

HOW TO USE PROGRAMS DIRECTLY FROM OUR WEB SITE

Our Web site at www.iFIT.com allows you to access basic programs, audio programs, and video programs directly from the internet. Additional options are soon to be available. See www.iFIT.com for details.

To use programs from our Web site, the treadmill must be connected to your home computer. See HOW TO CONNECT YOUR COMPUTER on page 18. In addition, you must have an internet connection and an internet service provider. A list of specific system requirements will be found on our Web site.

Follow the steps below to use a program from our Web site.

1 Insert the key fully into the console.

See HOW TO TURN ON THE POWER on page 11.

2 Select the iFIT.com mode.

When the key is inserted, the manual mode will be selected. To use a program from our Web site, press the iFIT.com button or press the Select Program button repeatedly until the indicator above the iFIT.com button lights.

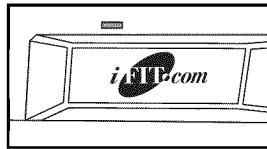

3 Go to your computer and start an internet connection.

4 Start your web browser, if necessary, and go to our Web site at www.iFIT.com.

5 Follow the desired links on our Web site to select a program.

Read and follow the on-line instructions for using a program.

6 Follow the on-line instructions to start the program.

When you start the program, an on-screen countdown will begin.

7 Return to the treadmill and stand on the foot rails. Find the clip attached to the key and slide the clip onto the waistband of your clothes.

When the on-screen countdown ends, the program will begin and the walking belt will begin to move. Hold the handrails, step onto the walking belt, and begin walking. During the program, an electronic “chirping” sound will alert you when the speed and/or incline of the treadmill is about to change. **CAUTION: Always listen for the “chirp” and be prepared for speed and/or incline changes.**

If the speed or incline settings are too high or too low, you can manually override the settings at any time by pressing the Speed or Incline buttons on the console. **However, when the next “chirp” is heard, the speed and/or incline will change to the next settings of the program.**

To stop the walking belt at any time, press the Stop button on the console. The Time/Pace display will begin to flash. To restart the program, press the Start button or the Speed + button. After a moment, the walking belt will begin to move at 1.0 mph. **When the next “chirp” is heard, the speed and incline will change to the next settings of the program.**

When the program is completed, the walking belt will stop and the Time/Pace display will begin to flash. Note: To use another program, press the Stop button and go to step 5.

Note: If the speed or incline of the treadmill does not change when a “chirp” is heard, make sure that the iFIT.com indicator is lit and that the Time/Pace display is not flashing. In addition, make sure that the audio cable is properly connected, that it is fully plugged in, and that it is not wrapped around a power cord.

8 Follow your progress with the displays.

See step 5 on page 12.

9 When the program has ended, remove the key.

See step 7 on page 14.

THE INFORMATION MODE/DEMO MODE

The console features an information mode that keeps track of the total number of miles that the walking belt has moved and the total number of hours that the treadmill has been operated. The information mode also allows you to switch the console from miles to kilometers. In addition, the information mode allows you to turn on and turn off the demo mode.

To select the information mode, hold down the Stop button while inserting the key into the console. When the information mode is selected, the following information will be shown:

The Incline/Distance display will show the total number of miles that the walking belt has moved.

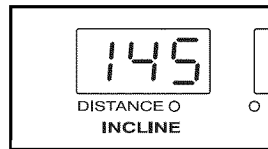

The Time/Pace display will show the total number of hours that the treadmill has been used.

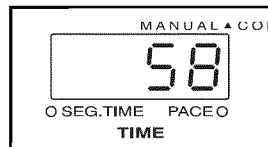

An "E" for English miles or an "M" for metric kilometers will appear in the Speed/Pace display. Press the Speed + button to change the unit of measurement.

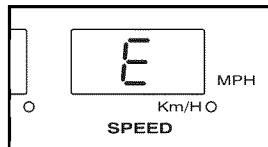

IMPORTANT: The Calories/Pulse display should be blank. If a "d" appears in the display, the console is in the "demo" mode. This mode is intended to be used only when a treadmill is displayed in a store. When the console is in the demo mode, the power cord can be plugged in, the key can be removed from the console, and the displays and indicators on the console will automatically light in a preset sequence, although the buttons on the console will not operate. **If a "d" appears in the Calories/Pulse display when the information mode is selected, press the Speed – button so the display is blank.**

To exit the information mode, remove the key from the console.

HOW TO USE THE AROMATHERAPY SYSTEM

To make your workouts more enjoyable, the console features an aromatherapy system. To use NordicTrack® REJUVENAIRE™ essential oils with the console, press the scent pads

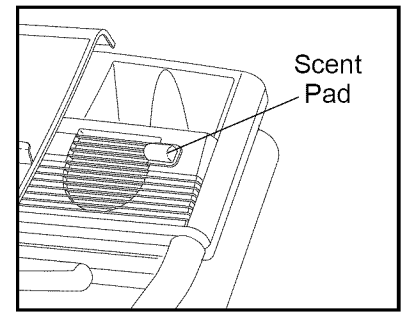

into the receptacles beside the fans. Deposit a few drops of essential oil onto each scent pad. As you exercise, turn on the fans to circulate the essential oil throughout your workout area. **For information about REJUVENAIRE scents and scent pads, call toll-free 1-800-215-7403.**

CAUTION: Keep the aromatherapy bottle out of the reach of children. Essential oil may irritate skin and is not intended for internal or topical use.

THE OPTIONAL CHEST PULSE SENSOR

An optional chest pulse sensor adds even more features to the console. The chest pulse sensor provides hands-free operation and continuously monitors your heart rate during your workouts. **To purchase the optional chest pulse sensor, call toll-free 1-800-734-2377.**

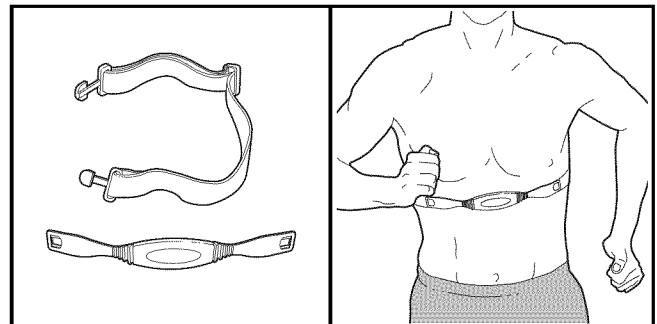

HOW TO FOLD AND MOVE THE TREADMILL

HOW TO FOLD THE TREADMILL FOR STORAGE

Before folding the treadmill, adjust the incline to the lowest position. If this is not done, the treadmill may be permanently damaged. Remove the key and unplug the power cord. **CAUTION:** You must be able to safely lift 45 pounds (20 kg) to raise, lower, or move the treadmill.

1. Hold the treadmill with your hands in the locations shown at the right. **CAUTION: To decrease the possibility of injury, bend your legs and keep your back straight. As you raise the treadmill, make sure to lift with your legs rather than your back.** Raise the treadmill about halfway to the vertical position.

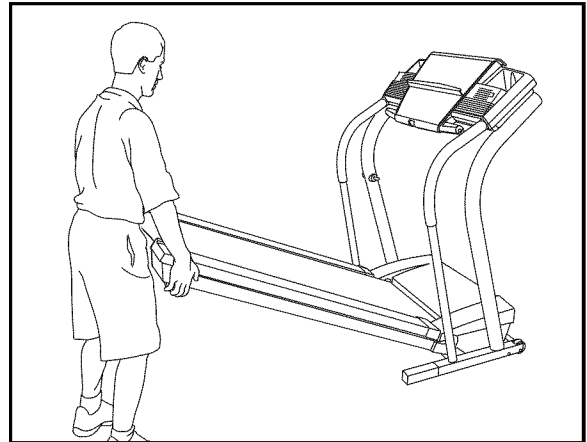

2. Move your right hand to the position shown and hold the treadmill firmly. Using your left hand, pull the latch knob to the left and hold it. Raise the treadmill until the latch pin is aligned with the indicated hole in the side of the treadmill. Insert the latch pin into the hole. **Make sure that the latch pin is fully inserted into the hole.**

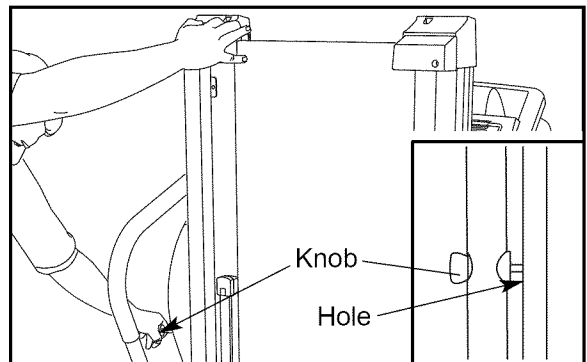

To protect the floor or carpet from damage, place a mat under the treadmill. Keep the treadmill out of direct sunlight. Do not leave the treadmill in the storage position in temperatures above 85° Fahrenheit.

HOW TO MOVE THE TREADMILL

Before moving the treadmill, convert the treadmill to the storage position as described above. **Make sure that the latch pin is fully inserted into the hole in the side of the treadmill.**

1. Hold the handrails as shown and place one foot against a wheel.
2. Tilt the treadmill back until it rolls freely on the front wheels. Carefully move the treadmill to the desired location. **Never move the treadmill without tipping it back. To reduce the risk of injury, use extreme caution while moving the treadmill. Do not attempt to move the treadmill over an uneven surface.**
3. Place one foot on wheel, and carefully lower the treadmill until it is resting in the storage position.



HOW TO LOWER THE TREADMILL FOR USE

1. Hold the upper end of the treadmill with your right hand as shown. Using your left hand, pull the latch knob to the left and hold it. Pivot the treadmill down until the frame is past the pin on the latch knob.

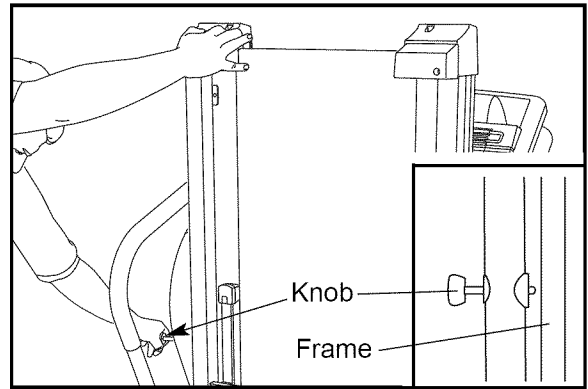

2. Hold the treadmill firmly with both hands, and lower the treadmill to the floor. **To decrease the possibility of injury, bend your legs and keep your back straight.**

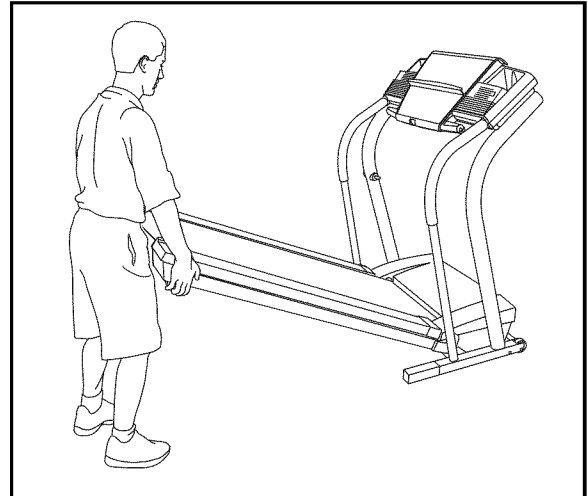

TROUBLESHOOTING

Most treadmill problems can be solved by following the steps below. Find the symptom that applies, and follow the steps listed. If further assistance is needed, please call our Customer Service Department toll-free at 1-888-825-2588, Monday through Friday, 6 a.m. until 6 p.m. Mountain Time (excluding holidays).

PROBLEM: The power does not turn on

SOLUTION: a. Make sure that the power cord is plugged into a surge suppressor, and that the surge suppressor is plugged into a properly grounded outlet (see page 9). Use only a single-outlet surge suppressor that meets all of the specifications described on page 9. Important: The treadmill is not compatible with GFCI-equipped outlets.

b. After the power cord has been plugged in, make sure that the key is fully inserted into the console.

c. Check the reset/off circuit breaker located on the treadmill frame near the power cord. If the switch protrudes as shown, the circuit breaker has tripped. To reset the circuit breaker, wait for five minutes and then press the switch back in.

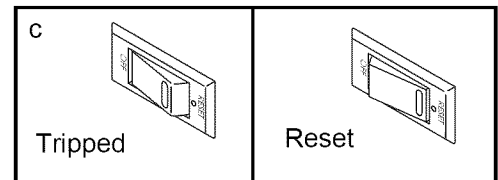

PROBLEM: The power turns off during use

SOLUTION: a. Check the reset/off circuit breaker (see the drawing above). If the circuit breaker has tripped, wait for five minutes and then press the switch back in.

b. Make sure that the power cord is plugged in. If the power cord is plugged in, unplug it, wait for five minutes, and then plug it back in.

c. Remove the key from the console. Reinsert the key fully into the console.

d. If the treadmill still will not run, please call our Customer Service Department, toll-free.

PROBLEM: The displays of the console do not function properly

SOLUTION: a. Remove the key from the console and **unplug the power cord**. Carefully tip the treadmill as shown in drawing a. Remove the Front Belly Pan Screws (3) and the Screws (83) from the hood. Make a note which holes the Screws are removed from. Raise the Uprights (69) and carefully remove the hood.

Locate the Reed Switch (10) and the Magnet (7) on the left side of the Pulley (8). Turn the Pulley until the Magnet is aligned with the Reed Switch. **Make sure that the gap between the Magnet and the Reed Switch is about 1/8"**. If necessary, loosen the Screw (27) and move the Reed Switch slightly. Retighten the Screw. Re-attach the hood, making sure the Screws are returned to the same hole they were removed from. Run the treadmill for a few minutes to check for a correct speed reading.

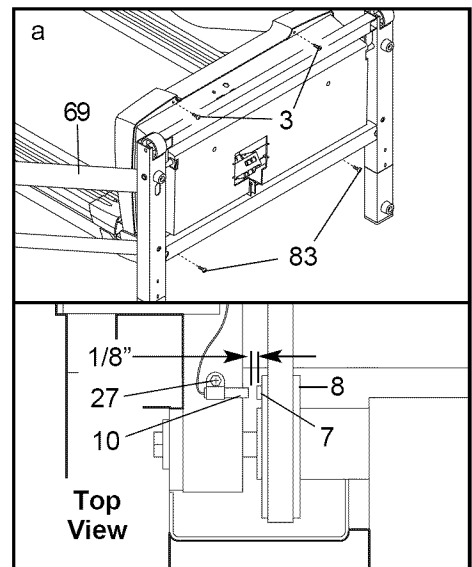

PROBLEM: The walking belt slows when walked on

SOLUTION: a. Use only a single-outlet surge suppressor that meets all of the specifications described on page 9.

b. If the walking belt is overtightened, treadmill performance may decrease and the walking belt may become damaged. Remove the key and **UNPLUG THE POWER CORD**. Using the allen wrench, turn both rear roller adjustment bolts counterclockwise, 1/4 of a turn. When the walking belt is properly tightened, you should be able to lift each side of the walking belt 3 to 4 inches off the walking platform. Be careful to keep the walking belt centered. Plug in the power cord, insert the key and run the treadmill for a few minutes. Repeat until the walking belt is properly tightened.

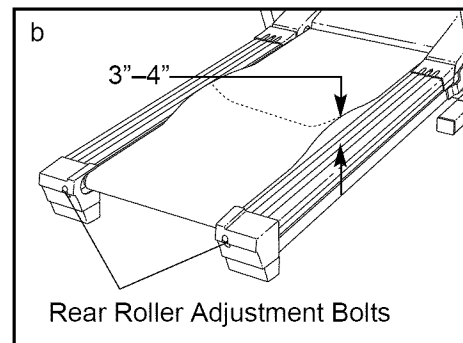

c. If the walking belt still slows when walked on, please call our Customer Service Department, toll-free.

PROBLEM: The walking belt is off-center or slips when walked on

SOLUTION: a. If the walking belt is off-center, remove the key and **UNPLUG THE POWER CORD**. **If the walking belt has shifted to the left**, use the allen wrench to turn the left rear roller bolt clockwise 1/2 of a turn; **if the walking belt has shifted to the right**, turn the left rear roller bolt counterclockwise 1/2 of a turn. Be careful not to overtighten the walking belt. Plug in the power cord, insert the key, and run the treadmill for a few minutes. Repeat until the walking belt is centered.

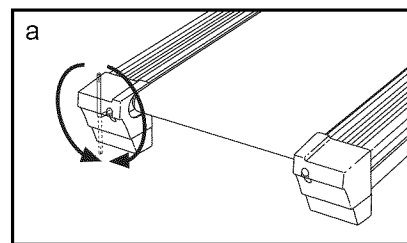

b. If the walking belt slips when walked on, first remove the key and **UNPLUG THE POWER CORD**. Using the allen wrench, turn both rear roller bolts clockwise, 1/4 of a turn. When the walking belt is correctly tightened, you should be able to lift each side of the walking belt 3 to 4 inches off the walking platform. Be careful to keep the walking belt centered. Plug in the power cord, insert the key, and carefully walk on the treadmill for a few minutes. Repeat until the walking belt is properly tightened.

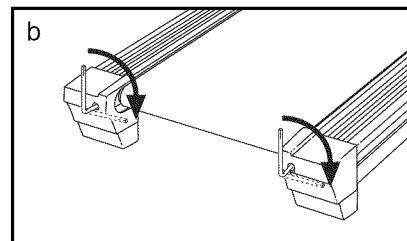

PROBLEM: The incline of the treadmill does not change correctly or does not change when iFIT.com CDs and videos are played

SOLUTION: a. With the key in the console, press one of the Incline buttons. **While the incline is changing, remove the key.** After a few seconds, re-insert the key. The treadmill will automatically rise to the maximum incline level and then return to the minimum level. This will recalibrate the incline.

CONDITIONING GUIDELINES

⚠️ WARNING: Before beginning this or any exercise program, consult your physician. This is especially important for individuals over the age of 35 or individuals with pre-existing health problems.

The pulse sensor is not a medical device. Various factors, including your movement, may affect the accuracy of heart rate readings. The sensor is intended only as an exercise aid in determining heart rate trends in general.

The following guidelines will help you to plan your exercise program. For more detailed exercise information, obtain a reputable book or consult your physician.

EXERCISE INTENSITY

Whether your goal is to burn fat or to strengthen your cardiovascular system, the key to achieving the desired results is to exercise with the proper intensity. The proper intensity level can be found by using your heart rate as a guide. The chart below shows recommended heart rates for fat burning and aerobic exercise.

HEART RATE TRAINING ZONES							
AEROBIC	165	155	145	140	130	125	115
MAX FAT BURN	145	138	130	125	118	110	103
FAT BURN	125	120	115	110	105	95	90
Age	20	30	40	50	60	70	80

To find the proper heart rate for you, first find your age near the bottom of the chart (ages are rounded off to the nearest ten years). Next, find the three numbers above your age. The three numbers define your “training zone.” The lower two numbers are recommended heart rates for fat burning; the higher number is the recommended heart rate for aerobic exercise.

To measure your heart rate during exercise, use the pulse sensor on the console. If your heart rate is too high or too low, adjust the speed and incline of the treadmill.

Fat Burning

To burn fat effectively, you must exercise at a relatively low intensity level for a sustained period of time. During the first few minutes of exercise, your body

uses easily accessible *carbohydrate calories* for energy. Only after the first few minutes does your body begin to use stored *fat calories* for energy. If your goal is to burn fat, adjust the speed and incline of the treadmill until your heart rate is near the lowest number in your training zone.

For maximum fat burning, adjust the speed and incline of the treadmill until your heart rate is near the middle number in your training zone.

Aerobic Exercise

If your goal is to strengthen your cardiovascular system, your exercise must be “aerobic.” Aerobic exercise is activity that requires large amounts of oxygen for prolonged periods of time. This increases the demand on the heart to pump blood to the muscles, and on the lungs to oxygenate the blood. For aerobic exercise, adjust the speed and incline of the treadmill until your heart rate is near the highest number in your training zone.

WORKOUT GUIDELINES

Each workout should include the following three parts:

A Warm-up—Start each workout with 5 to 10 minutes of stretching and light exercise. A proper warm-up increases your body temperature, heart rate and circulation in preparation for exercise.

Training Zone Exercise—After warming up, increase the intensity of your exercise until your pulse is in your training zone for 20 to 60 minutes. (During the first few weeks of your exercise program, do not keep your pulse in your training zone for longer than 20 minutes.) Breathe regularly and deeply as you exercise—never hold your breath.

A Cool-down—Finish each workout with 5 to 10 minutes of stretching to cool down. This will increase the flexibility of your muscles and will help prevent post-exercise problems.

EXERCISE FREQUENCY

To maintain or improve your condition, complete three workouts each week, with at least one day of rest between workouts. After a few months, you may complete up to five workouts each week if desired. The key to success is to make exercise a regular and enjoyable part of your everyday life.

SUGGESTED STRETCHES

The correct form for several basic stretches is shown at the right. Move slowly as you stretch—never bounce.

1. Toe Touch Stretch

Stand with your knees bent slightly and slowly bend forward from your hips. Allow your back and shoulders to relax as you reach down toward your toes as far as possible. Hold for 15 counts, then relax. Repeat 3 times. Stretches: Hamstrings, back of knees and back.

2. Hamstring Stretch

Sit with one leg extended. Bring the sole of the opposite foot toward you and rest it against the inner thigh of your extended leg. Reach toward your toes as far as possible. Hold for 15 counts, then relax. Repeat 3 times for each leg. Stretches: Hamstrings, lower back and groin.

3. Calf/Achilles Stretch

With one leg in front of the other, reach forward and place your hands against a wall. Keep your back leg straight and your back foot flat on the floor. Bend your front leg, lean forward and move your hips toward the wall. Hold for 15 counts, then relax. Repeat 3 times for each leg. To cause further stretching of the achilles tendons, bend your back leg as well. Stretches: Calves, achilles tendons and ankles.

4. Quadriceps Stretch

With one hand against a wall for balance, reach back and grasp one foot with your other hand. Bring your heel as close to your buttocks as possible. Hold for 15 counts, then relax. Repeat 3 times for each leg. Stretches: Quadriceps and hip muscles.

5. Inner Thigh Stretch

Sit with the soles of your feet together and your knees outward. Pull your feet toward your groin area as far as possible. Hold for 15 counts, then relax. Repeat 3 times. Stretches: Quadriceps and hip muscles.

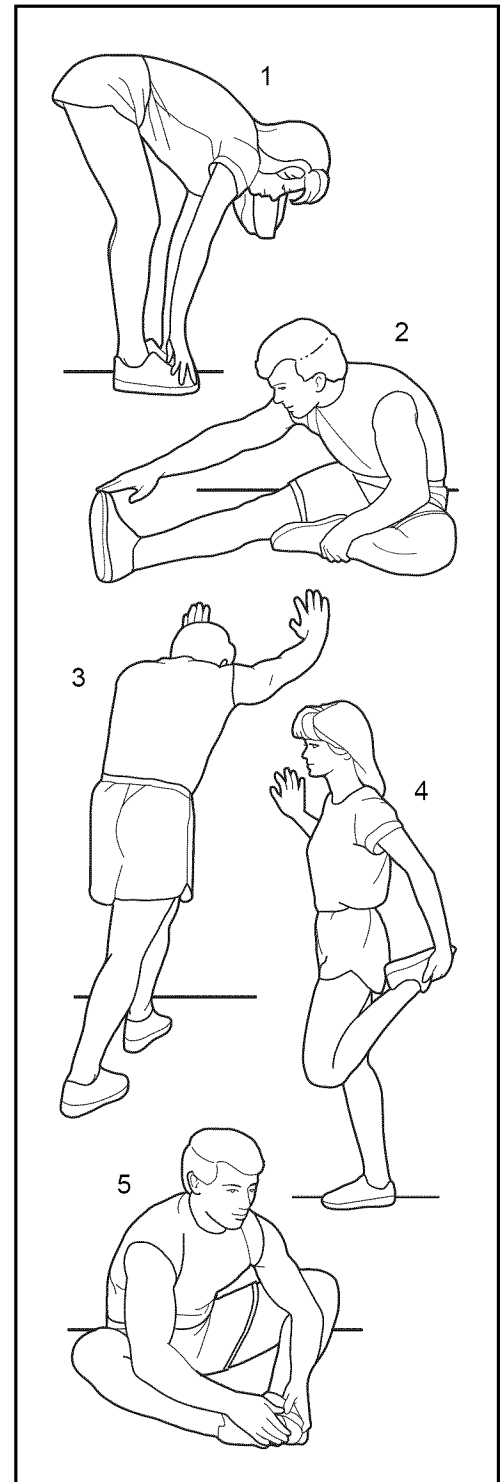

NOTES

PART LIST—Model No. NTL10841

R1103A

To locate the parts listed below, see the EXPLODED DRAWING attached in the center of this manual.

Key No.	Qty.	Description	Key No.	Qty.	Description
1	2	Foot Rail Insert	51	1	Right Foot Rail Cap
2	2	Foot Rail	52	1	Walking Platform
3	4	Front Belly Pan Screw/ Rear Foot Screw	53	2	4" Bolt
4	1	Left Foot Rail Cap	54	4	Platform Bolt
5	2	Frame Pivot Bolt	55	2	Spring Pad
6	2	Frame Pivot Spacer	56	2	Spring
7	1	Magnet	57	1	Ground Wire
8	1	Front Roller/Pulley	58	1	Rear Endcap (Right)
9	4	Frame Pivot Nut	59	2	Rear Roller Adj. Bolt
10	1	Reed Switch/Sensor Wire	60	1	Warning Decal
11	4	U-nut	61	1	Allen Wrench
12	1	Reed Switch Clip	62	1	Rear Roller
13	1	Lift Frame	63	1	Audio Wire
14	1	Walking Belt	64	1	Catch
15*	1	Motor Assembly	65	1	Left Fan Housing
16	1	Motor	66	1	Console Frame
17	1	Pulley/Flywheel/Fan	67	2	Spring Pad Screw
18	1	Motor Belt	68	1	Latch Knob
19	1	Motor Pivot Nut	69	1	Upright
20	5	Motor Tension Nut	70	1	Latch Knob Sleeve
21	1	Incline Motor Bolt (Top)	71	1	Spring
22	1	Motor Pivot Bolt	72	1	Latch Pin Collar
23	1	Hood	73	1	Pin Clip
24	1	Incline Motor Bolt (Lower)	74	1	Latch Pin
25	1	Motor Tension Bolt	75	1	Filter Wire
26	1	Hole Plug	76	2	Pulse Grip
27	12	Screw	77	4	Handrail Bushing
28	1	Transformer	78	4	4 1/2" Bolt
29	1	Controller	79	2	Upright Endcap
30	1	Electronics Plate	80*	1	Latch Assembly
31	1	Motor Controller Wire	81	1	Console Base
32	1	Front Roller Adj. Bolt	82	1	Console
33	1	Right Rear Foot	83	8	Screw
34	6	Roller Washer	84	1	Key/Clip
35	1	Latch Knob Spacer	85	1	iFIT.com Wire
36	1	Incline Motor	86	1	Jack
37	1	Incline Motor Stop	87	1	Aromatherapy Kit
38	1	Motor Belly Pan	88	1	Console Back
39	1	Audio Wire Nut	89	1	Releaseable Tie
40	2	Static Decal	90	25	Console Screw
41	1	Console Ground Wire	91	2	Cable Tie Clamp
42	1	Power Cord	92	5	8" Cable Tie
43	1	Reset/Off Circuit Breaker	93	2	Lift Pivot Bolt
44	4	Spring Bolt	94	2	Wheel Bolt
45	6	Belt Guide Screw	95	2	Wheel
46	2	Belt Guide	96	1	Rear Endcap (Left)
47	6	1" Tek Screw	97	1	Grommet
48	1	Motor Star Washer	98	1	Upright Wire Harness
49	4	Platform Nut	99	6	Base Pad
50	4	Spring Nut	100	9	3/4" Screw
			101	1	Motor Washer

Key No.	Qty.	Description	Key No.	Qty.	Description
102	2	Extension Leg	118	2	Handrail w/Foam
103	2	Extension Cap	119	2	Handrail Foam
104	2	Incline Warning Decal	120	1	Left Rear Foot
105	1	Right Foam Trim	#	2	Thick Base Pad
106*	1	Extension Leg Assembly	#	1	14" Blue Wire, 2F
107	2	Fan	#	1	12" Blue Wire, 2F
108	1	Book Holder	#	1	4" Blue Wire, M/F
109	1	Power Cord Grommet	#	1	8" Black Wire, M/F
110	1	Frame	#	1	12" Green Wire, 2 Ring
111	1	Left Rear Foam Trim	#	1	4" Green Wire, F/Ring
112	2	Roller Star Washer	#	1	10" Red Wire, M/F
113	2	Spring Plate	#	1	User's Manual
114	1	Left Front Foam Trim			
115	1	Left Cup Holder			
116	1	Right Cup Holder			
117	1	Right Fan Housing			

* Includes all parts shown in box
These parts are not illustrated

ORDERING REPLACEMENT PARTS

To order replacement parts, call our Customer Service Department toll-free at 1-888-825-2588, Monday through Friday, 6 a.m. until 6 p.m. Mountain Time (excluding holidays). When ordering parts, please be prepared to give the following information:

- the MODEL NUMBER OF THE PRODUCT (NTL10841)
- the NAME OF THE PRODUCT (NordicTrack® C2000 treadmill)
- the SERIAL NUMBER OF THE PRODUCT (see the front cover of this manual)
- the KEY NUMBER AND DESCRIPTION OF THE PART(S) (see the PART LIST on pages 30 and 31 and the EXPLODED DRAWING attached in the center of this manual)

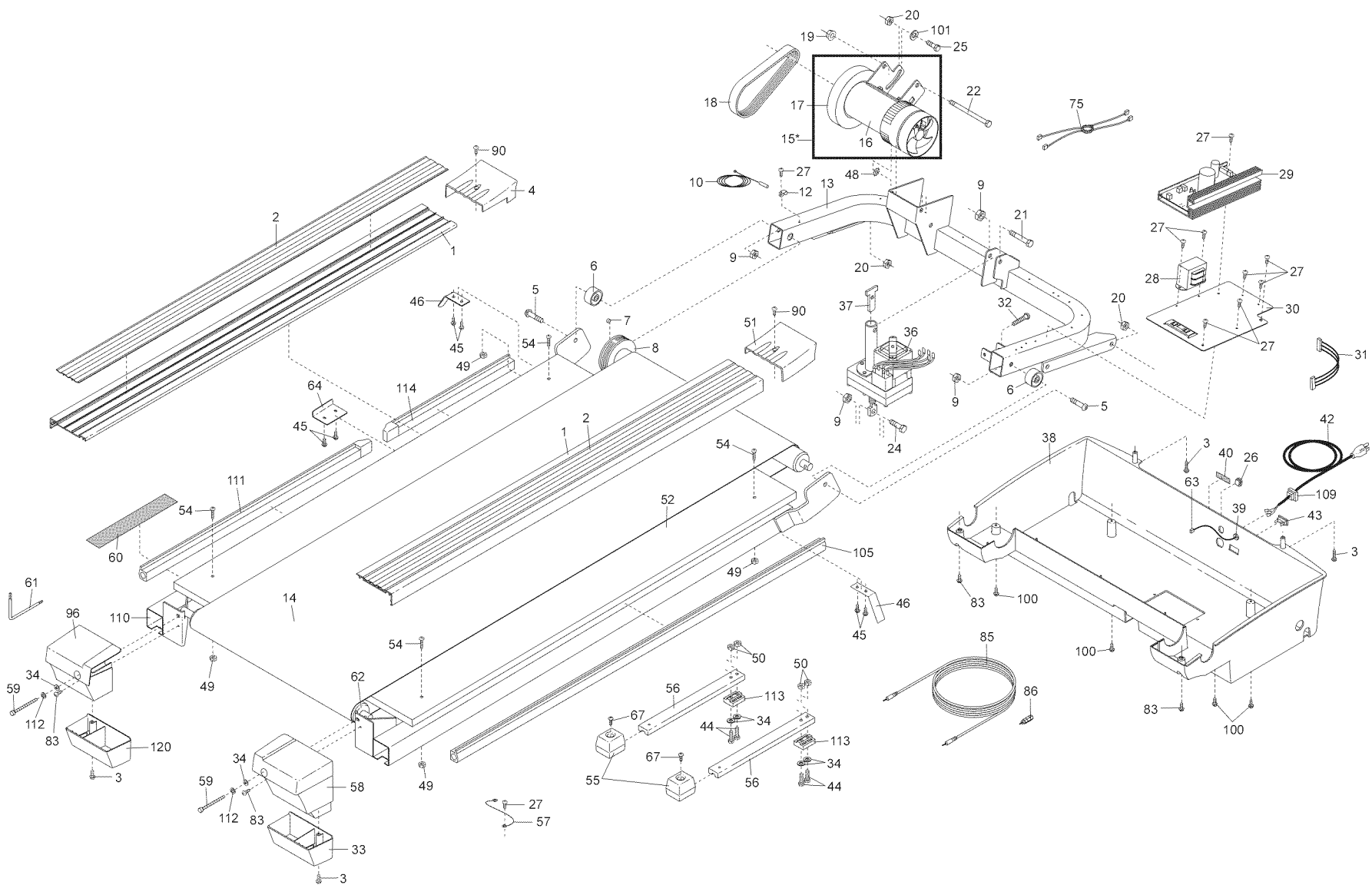

EXPLODED DRAWING—Model No. NTL10841

R1103A

LIMITED WARRANTY

WHAT IS COVERED—The entire NordicTrack® C2000 treadmill ("Product") is warranted to be free of all defects in material and workmanship.

WHO IS COVERED—The original purchaser or any person receiving the Product as a gift from the original purchaser.

HOW LONG IS IT COVERED—ICON Health & Fitness, Inc. ("ICON"), warrants the motor for three years after the date of purchase. The belt and deck are covered for two years after the date of purchase. All mechanical components are covered for two years after the date of purchase. All electrical components are covered for two years after the date of purchase. Labor is covered for one year. The hood, covers, belly pan, and decals are covered for six months after the date of purchase.

WHAT WE DO TO CORRECT COVERED DEFECTS—We will ship to you, without charge, any replacement part or component, providing the repairs are authorized by ICON first and are performed by an ICON trained and authorized service provider, or, at our option, we will replace the Product.

WHAT IS NOT COVERED—Any failures or damage caused by unauthorized service, misuse, accident, negligence, improper assembly or installation, alterations, modifications without our written authorization or by failure on your part to use, operate, and maintain as set out in your User's Manual ("Manual"). This warranty does not extend to products used for commercial or rental purposes or to products used as store display modules.

WHAT YOU MUST DO—Always retain proof of purchase, such as your bill of sale; store, operate, and maintain the Product as specified in the Manual; notify our Customer Service Department of any defect within 10 days after discovery of the defect; as instructed, return any defected part for replacement or, if necessary, the entire product, for repair.

USER'S MANUAL—It is VERY IMPORTANT THAT YOU READ THE MANUAL before operating the Product. Remember to do the periodic maintenance requirements specified in the Manual to assure proper operation and your continued satisfaction.

HOW TO GET PARTS AND SERVICE—Simply call our Customer Service Department at 1-888-825-2588 and tell them your name and address and the serial number of your Product. They will tell you how to get a part replaced, or if necessary, arrange for service where your Product is located or advise you how to ship the Product for service. Before shipping, always obtain a Return Authorization Number (RA No.) from our Customer Service Department; securely pack your Product (save the original shipping carton if possible); put the RA No. on the outside of the carton and insure the product. Include a letter explaining the product or problem and a copy of your proof of purchase if you believe the service is covered by warranty.

ICON is not responsible or liable for indirect, special or consequential damages arising out of or in connection with the use or performance of the product or damages with respect to any economic loss, loss of property, loss of revenues or profits, loss of enjoyment or use, costs of removal, installation or other consequential damages of whatsoever nature. Some states do not allow the exclusion or limitation of incidental or consequential damages. Accordingly, the above limitation may not apply to you.

The warranty extended hereunder is in lieu of any and all other warranties and any implied warranties of merchantability or fitness for a particular purpose is limited in its scope and duration to the terms set forth herein. Some states do not allow limitations on how long an implied warranty lasts. Accordingly, the above limitation may not apply to you.

No one is authorized to change, modify or extend the terms of this limited warranty.

This warranty gives you specific legal rights and you may have other rights which vary from state to state.

ICON HEALTH & FITNESS, INC., 1500 S. 1000 W., LOGAN, UT 84321-9813