

PRO-FORM CrossTrainer **56**

Model No. PFEX39931

Serial No. _____

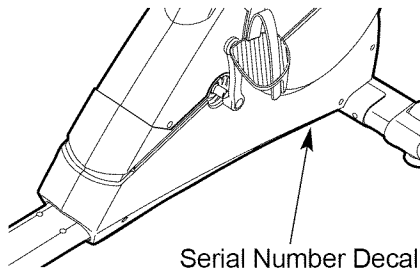

QUESTIONS?

If you have questions, or if there are missing parts, we will guarantee complete satisfaction through direct assistance from our factory.

TO AVOID DELAYS, PLEASE CALL DIRECT TO OUR TOLL-FREE CUSTOMER HOT LINE. The trained technicians on our customer hot line will provide immediate assistance, free of charge to you.

CUSTOMER HOT LINE:

1-800-999-3756

Mon.-Fri., 6 a.m.-6 p.m. MST

CAUTION

Read all precautions and instructions in this manual before using this equipment. Keep this manual for future reference.

USER'S MANUAL

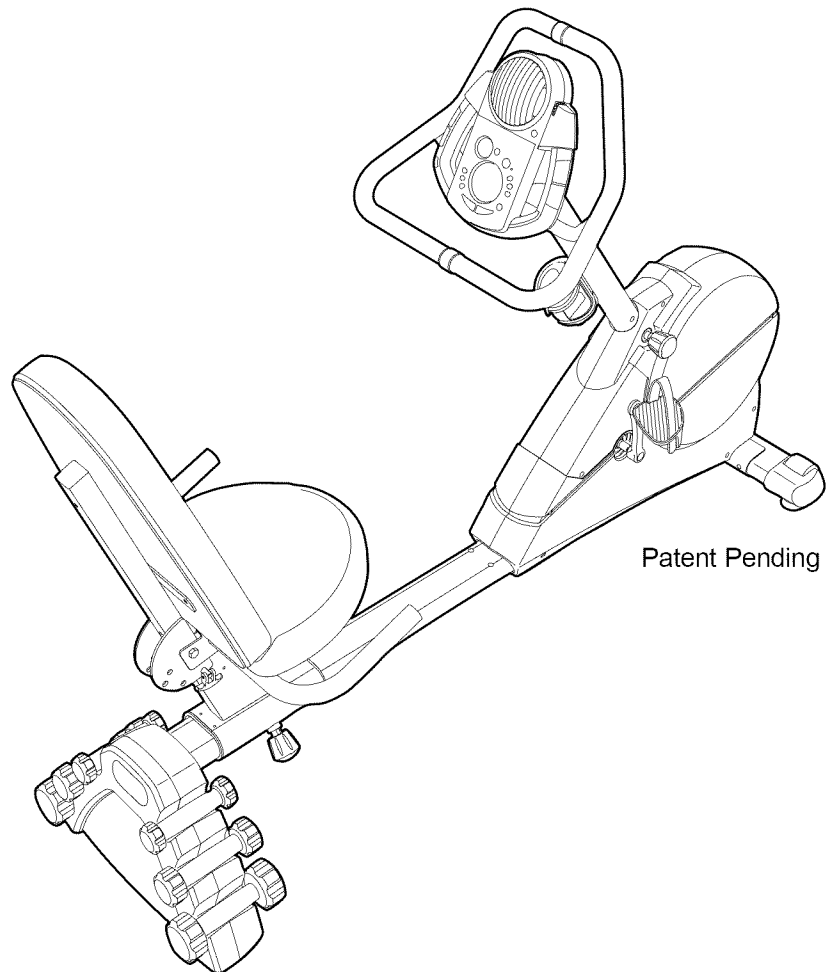

Visit our website at

www.proform.com

*new products, prizes,
fitness tips, and much more!*

TABLE OF CONTENTS

IMPORTANT PRECAUTIONS	.2
BEFORE YOU BEGIN	.3
ASSEMBLY	.4
HOW TO USE THE RECUMBENT CYCLE	.8
RECUMBENT CYCLE EXERCISE GUIDELINES	.19
WEIGHT BENCH EXERCISE GUIDELINES	.20
MAINTENANCE AND TROUBLESHOOTING	.21
PART LIST	.22
EXPLODED DRAWING	.23
HOW TO ORDER REPLACEMENT PARTS	.Back Cover
LIMITED WARRANTY	.Back Cover

IMPORTANT PRECAUTIONS

⚠ WARNING: To reduce the risk of serious injury, read the following important precautions before using the crosstrainer.

1. Read all instructions in this manual before using the crosstrainer.
2. It is the responsibility of the owner to ensure that all users of the crosstrainer are adequately informed of all precautions.
3. The crosstrainer is intended for home use only. Do not use the crosstrainer in a commercial, rental, or institutional setting.
4. Place the crosstrainer on a level surface, with a mat beneath it to protect the floor or carpet. Keep the crosstrainer indoors, away from moisture and dust.
5. Inspect and properly tighten all parts regularly. Replace any worn parts immediately.
6. Keep children under age 12 and pets away from the crosstrainer at all times.
7. The crosstrainer should not be used by persons weighing more than 250 pounds.
8. Wear appropriate exercise clothing when using the crosstrainer; do not wear clothing that could become caught on the crosstrainer. Always wear shoes for foot protection.
9. Before using the weight bench, always adjust the seat to the farthest forward position. Never sit on the backrest or the headrest; doing so could cause the crosstrainer to tip, resulting in injury.
10. Keep your back straight when using the crosstrainer; do not arch your back.
11. The crosstrainer includes three pairs of hand weights. Do not use other weights with the crosstrainer.
12. When you stop pedaling, allow the pedals to slowly come to a stop.
13. The pulse sensor is not a medical device. Various factors may affect the accuracy of heart rate readings. The pulse sensor is intended only as an exercise aid in determining heart rate trends in general.
14. If you feel pain or dizziness while exercising, stop immediately and begin cooling down.

⚠ WARNING: Before beginning this or any exercise program, consult your physician. This is especially important for persons over the age of 35 or persons with pre-existing health problems. Read all instructions before using. ICON assumes no responsibility for personal injury or property damage sustained by or through the use of this product.

BEFORE YOU BEGIN

Congratulations for selecting the new PROFORM® CROSSTRAINER 56. The unique PROFORM® CROSSTRAINER 56 combines a comfortable recumbent cycle with a convenient weight bench to let you enjoy both aerobic exercise and strength training exercise in the convenience of your home.

For your benefit, read this manual carefully before you use the crosstrainer. If you have questions after reading this manual, please call our Customer Service Department toll-free at 1-800-999-3756, Monday

through Friday, 6 a.m. until 6 p.m. Mountain Time (excluding holidays). To help us assist you, please note the product model number and serial number before calling. The model number is PFEX39931. The serial number can be found on a decal attached to the crosstrainer (see the front cover of this manual for the location of the decal).

Before reading further, please familiarize yourself with the parts that are labeled in the drawing below.

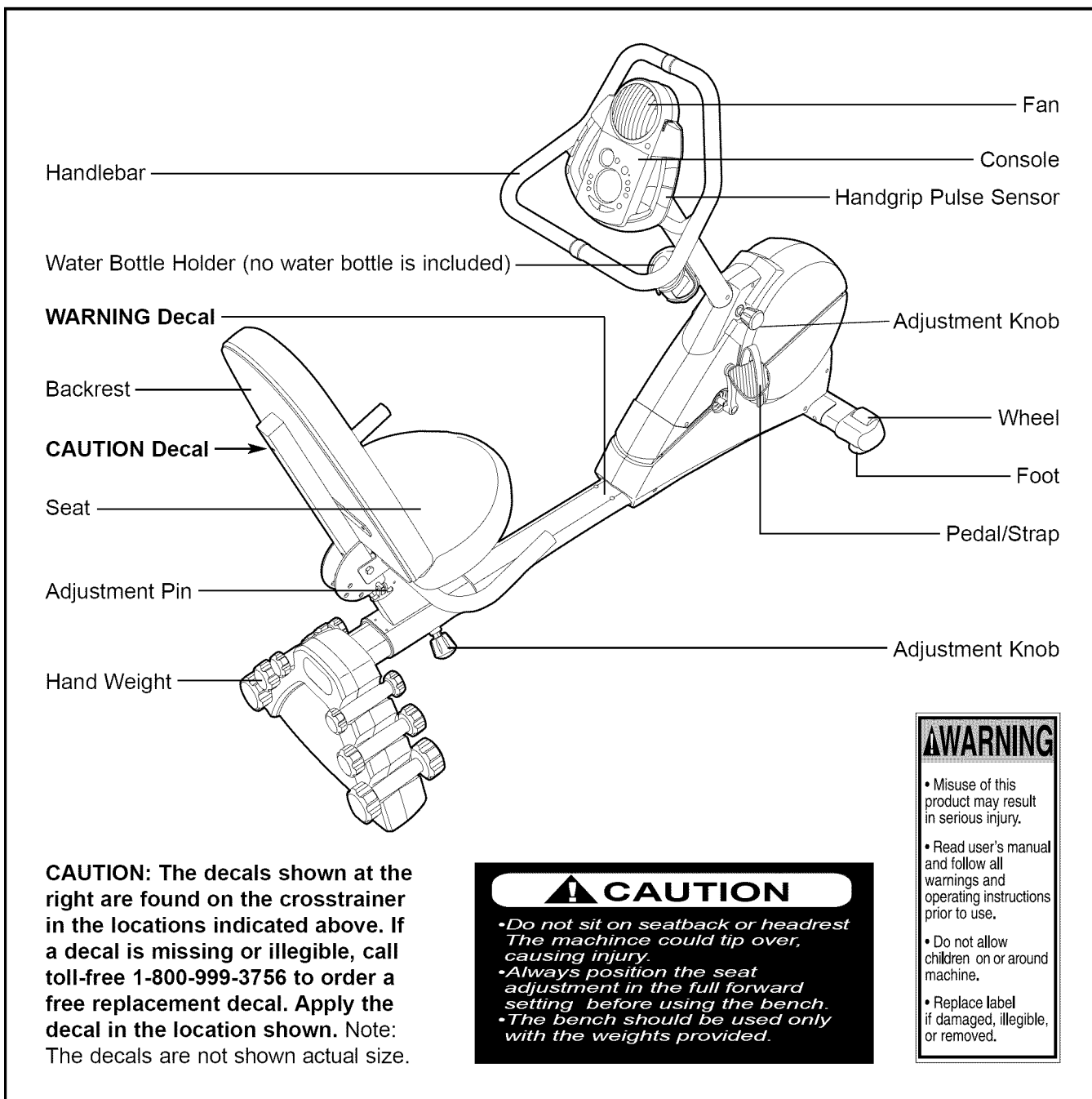

CAUTION: The decals shown at the right are found on the crosstrainer in the locations indicated above. If a decal is missing or illegible, call toll-free 1-800-999-3756 to order a free replacement decal. Apply the decal in the location shown. Note: The decals are not shown actual size.



CAUTION

- Do not sit on seatback or headrest. The machine could tip over, causing injury.
- Always position the seat adjustment in the full forward setting before using the bench.
- The bench should be used only with the weights provided.

WARNING

- Misuse of this product may result in serious injury.
- Read user's manual and follow all warnings and operating instructions prior to use.
- Do not allow children on or around machine.
- Replace label if damaged, illegible, or removed.

ASSEMBLY

Assembly requires two persons. Place all parts of the crosstrainer in a cleared area and remove the packing materials. Do not dispose of the packing materials until assembly is completed. **In addition to the included allen wrenches, assembly requires a phillips screwdriver** , **an adjustable wrench**  **and a rubber mallet** .

As you assemble the crosstrainer, use the drawings below to identify the small parts used in assembly. The number in parenthesis below each drawing refers to the key number of the part, from the PART LIST on page 22. The second number refers to the quantity used in assembly. **Note: Some small parts may have been pre-assembled for shipping. If a part is not in the parts bag, check to see if it has been pre-assembled.**

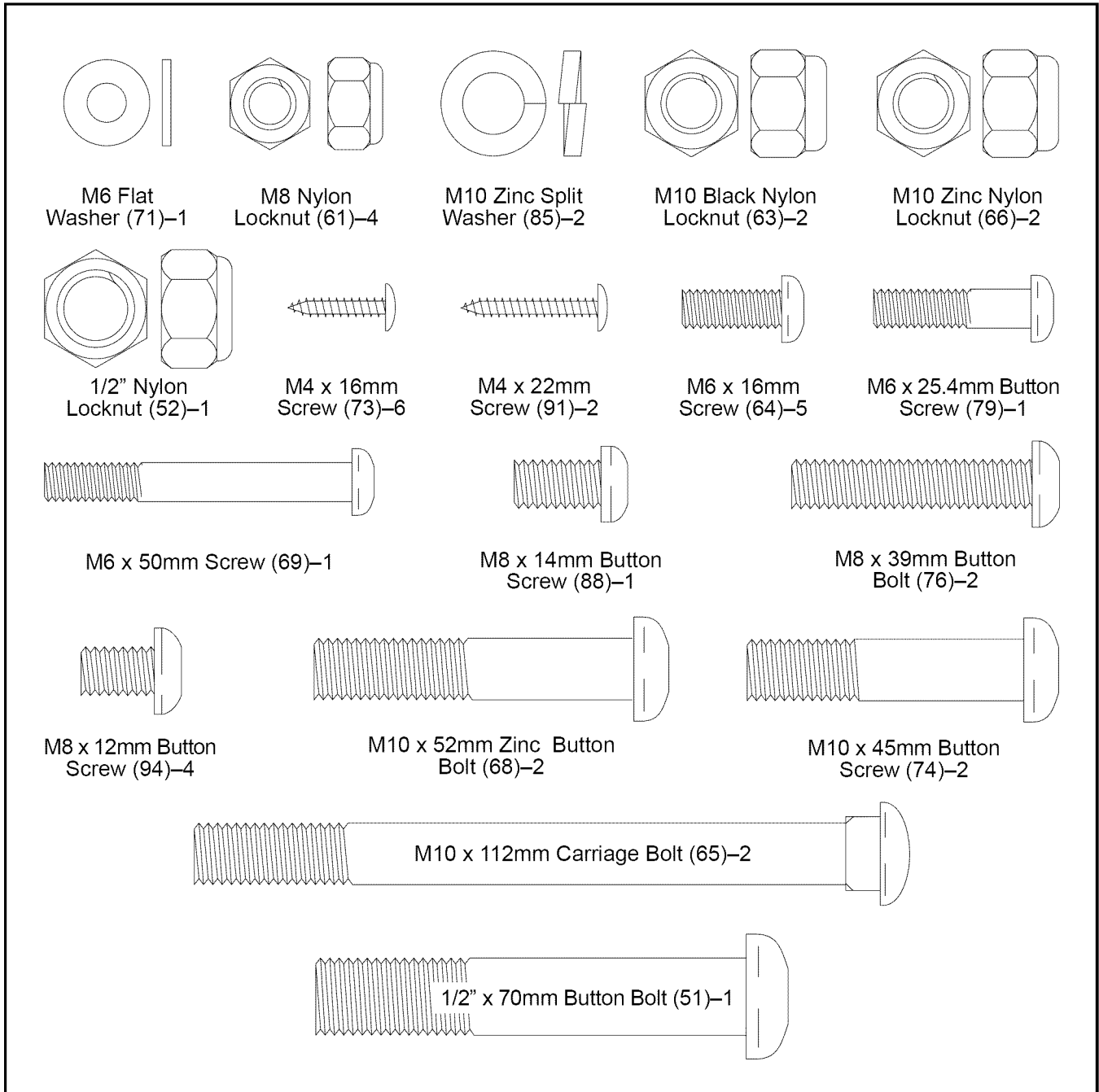

1. While another person lifts the front of the Frame (1), attach the Front Stabilizer (2) to the Frame with two M10 x 112mm Carriage Bolts (65) and two M10 Black Nylon Locknuts (63). **Make sure that the Front Stabilizer is turned so the Wheels (30) are not touching the floor.**

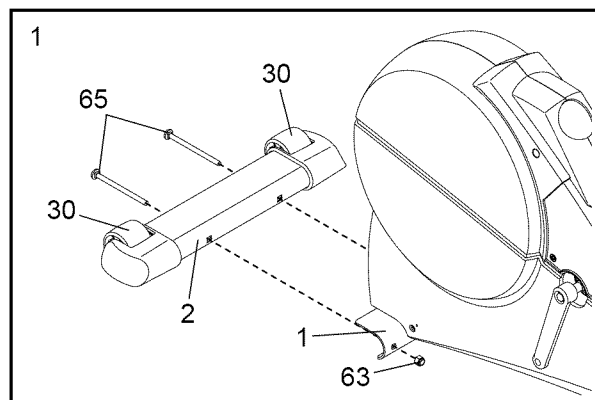

2. Orient the Frame Rail (3) as shown, with the hexagonal holes in the indicated position. Insert the end of the Frame Rail into the Rear Stabilizer Covers (7, 8) as shown. Attach the Rear Stabilizer Covers with two M10 x 45mm Button Screws (74).

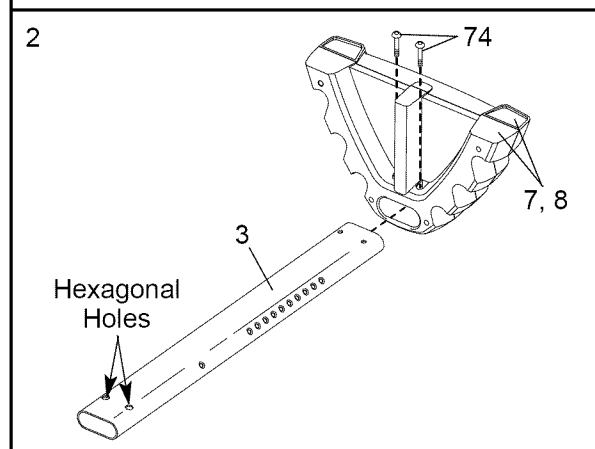

3. Locate the Knob (not shown) on the Seat Carriage (4). Turn the Knob counterclockwise two or three turns to loosen it. Next, pull the Knob, slide the Seat Carriage onto the Frame Rail (3), and then release the Knob. Make sure that the Seat Carriage is oriented as shown. **Move the Seat Carriage back and forth slightly until it locks into position.** Then, tighten the Knob.

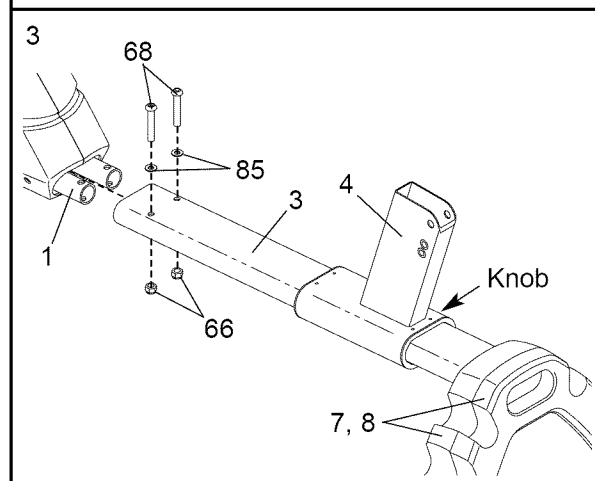

Slide the Frame Rail (3) onto the indicated round tubes on the Frame (1). Attach the Frame Rail with two M10 x 52mm Zinc Button Bolts (68), two M10 Zinc Split Washers (85), and two M10 Zinc Nylon Locknuts (66).

Set the six Hand Weights (not shown) on the Rear Stabilizer Covers (7, 8) as shown on page 3.

4. With the help of a second person, slide the Backrest Frame (5) onto the top of the Seat Carriage (4). Next, slide the bracket on the Seat Frame (6) over the rounded brackets on the Backrest Frame. Align the indicated holes in the Seat Frame, the Backrest Frame, and the Seat Carriage, and insert the 1/2" x 70mm Button Bolt (51) into the holes. Then, tighten the 1/2" Nylon Locknut (52) onto the Bolt.

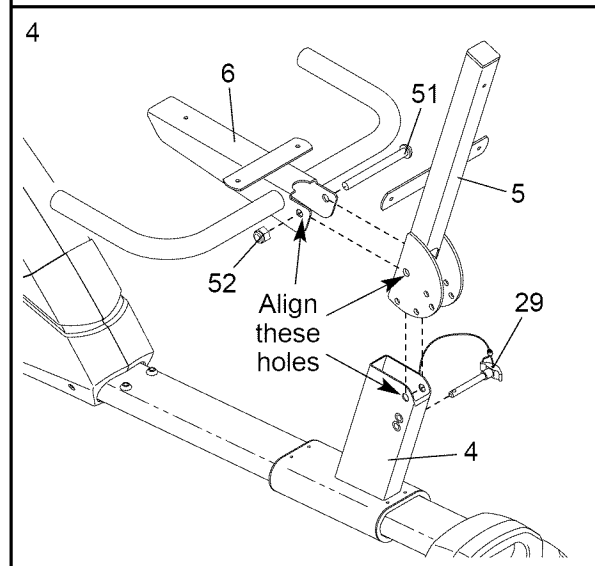

Pivot the Backrest Frame (5) up until it is nearly vertical. Insert the Adjustment Pin (29) into the lowest hole in the rounded brackets on the Backrest Frame and through the corresponding hole in the Seat Carriage (4).

- Attach the Seat (12) to the Seat Frame (6) with three M6 x 16mm Screws (64).

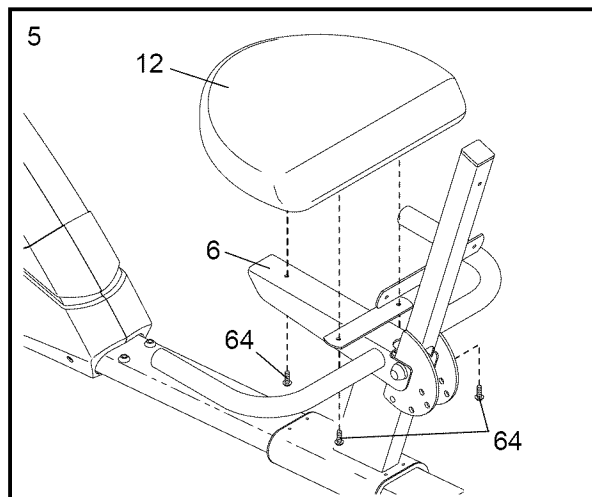

- Attach the Backrest (10) to the Backrest Frame (5) with two M6 x 16mm Screws (64), an M6 x 50mm Screw (69), and an M6 Flat Washer (71).

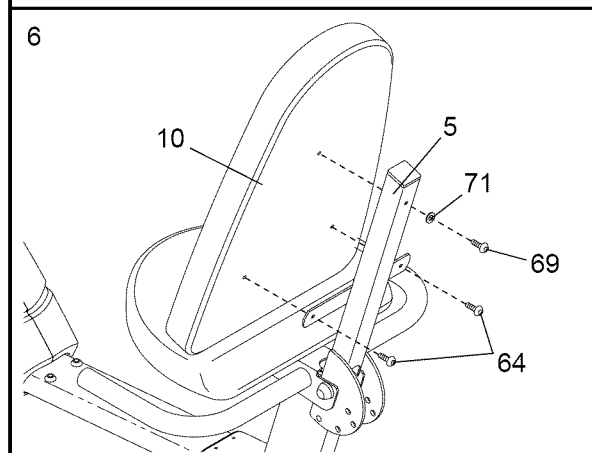

- While another person holds the Upright (13) in the position shown, connect the Upper Wire Harness (35) to the Lower Wire Harness (36). **Carefully pull the upper end of the Upper Wire Harness to remove any slack from the Wire Harnesses.**

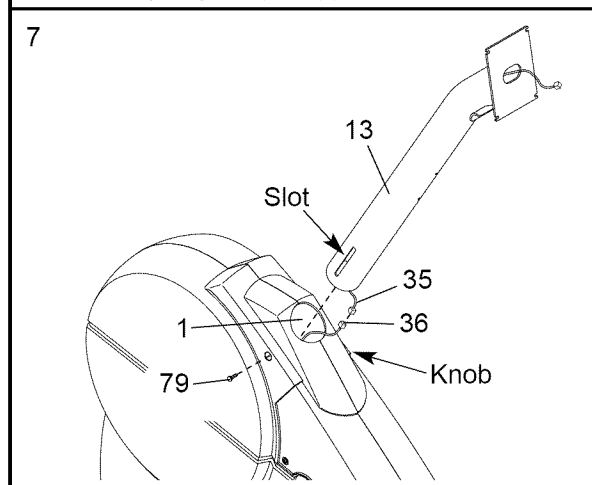

Turn the Knob (not shown) on the right side of the Frame (1) counterclockwise two or three turns to loosen it. Next, pull the Knob, insert the Upright (13) into the Frame, and then release the Knob. **Move the Upright up and down slightly until it locks into position. Be careful to avoid pinching the Wire Harnesses (35, 36).** Tighten the indicated M6 x 25.4mm Button Screw (79) into the slot in the Upright.

- While another person holds the Console (16) in the position shown, connect the wire harness on the Console to the Upper Wire Harness (35). Insert the excess wire harness into the Upright (13).

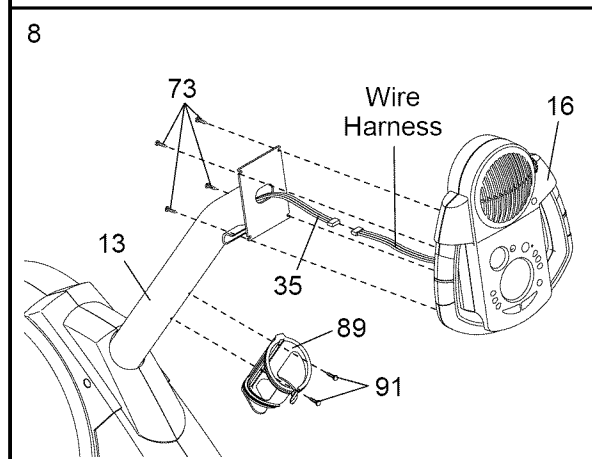

Attach the Console (16) to the Upright (13) with four M4 x 16mm Screws (73). **Be careful to avoid pinching the wire harnesses.**

Attach the Water Bottle Holder (89) to the Upright (13) with two M4 x 22mm Screws (91).

- Slide the two Handlebar Collars (77) onto the Left Handlebar (11). Insert the Right Handlebar (15) into the Left Handlebar. Connect the Handlebar Collars, the Left Handlebar, and the Right Handlebar with two M4 x 16mm Screws (73).

Attach the Handlebar Bracket (95) to the Left and Right Handlebars (11, 15) with four M8 x 12mm Button Screws (94).

Attach the Handlebar Bracket (95) to the Upright (13) with two M8 x 39mm Button Bolts (76), two M8 Nylon Locknuts (61), and an M8 x 14mm Button Screw (88).

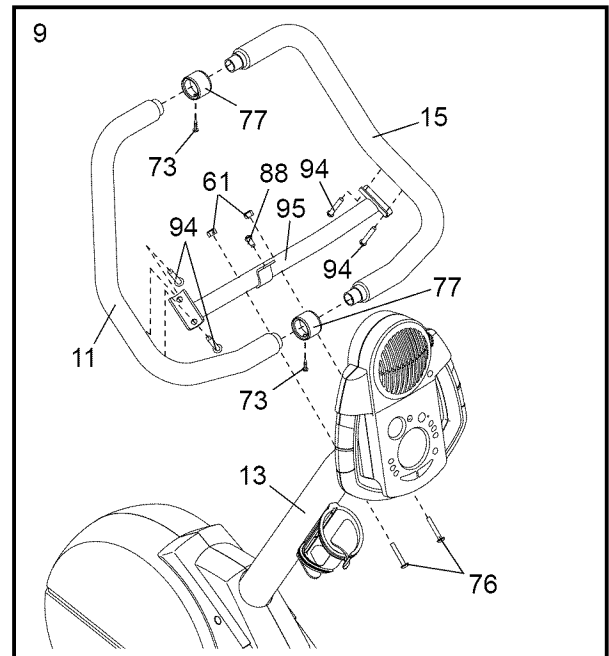

- The Console (16) requires four “D” batteries (not included); alkaline batteries are recommended. Remove the indicated screw from the battery drawer. Pull the battery drawer open and insert four batteries. **Make sure that the batteries are oriented as shown by the markings inside the battery drawer.** Close the battery drawer and reattach the screw. Note: When the batteries are installed correctly, the fan will turn on for a moment.

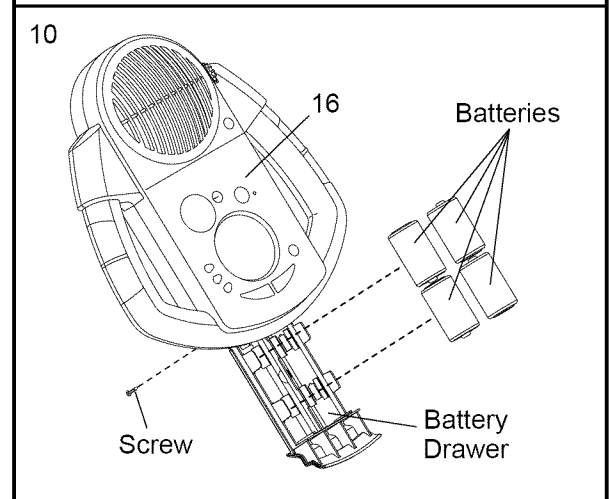

- Identify the Left Pedal (24), which is marked with an “L.” Using an adjustable wrench, **firmly tighten** the Left Pedal *counterclockwise* into the Left Crank Arm (42). Tighten the Right Pedal (not shown) *clockwise* into the Right Crank Arm (not shown) in the same way. **Important: Tighten both Pedals as firmly as possible. After using the crosstrainer for one week, retighten the Pedals. For the best performance, the Pedals must be kept properly tightened.**

Adjust the Left Pedal Strap (25) to the desired position and press the end of the Strap onto the tab on the Left Pedal (24). Adjust the Right Pedal Strap (not shown) in the same way.

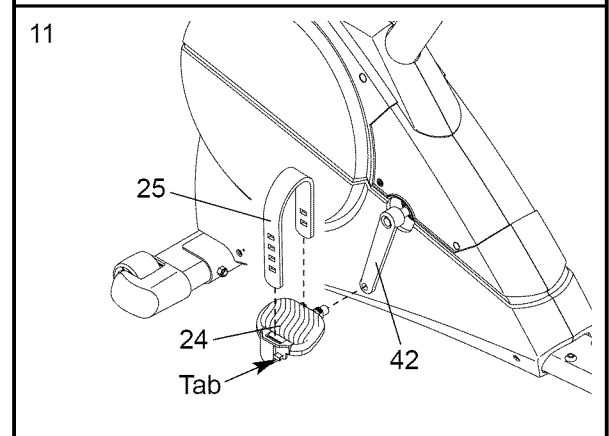

- Make sure that all parts of the crosstrainer are properly tightened.** Note: Some hardware may be left over after assembly is completed. To protect the floor or carpet from damage, place a mat under the crosstrainer.

HOW TO USE THE RECUMBENT CYCLE

The crosstrainer features a recumbent cycle for aerobic exercise, and a convenient weight bench for strength training exercise. To use the recumbent cycle, see pages 8 to 19. To use the weight bench, see page 20.

HOW TO ADJUST THE BACKREST

When the recumbent cycle is used, the backrest should be in the upright position. To adjust the backrest, first pull out the adjustment pin. Raise the backrest until it is nearly vertical, and then insert the adjustment pin into the indicated hole in the rounded brackets and the corresponding hole in the seat carriage.

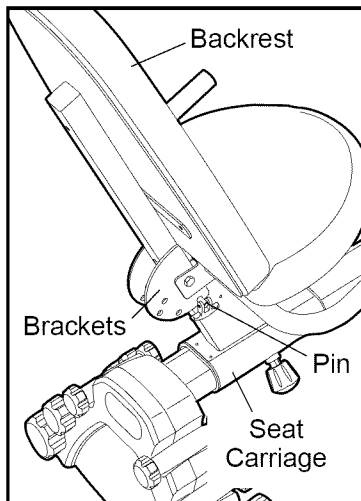

HOW TO ADJUST THE SEAT

For effective exercise, the seat should be in the proper position. As you pedal, there should be a slight bend in your knees when the pedals are in the farthest position. To adjust the seat, first turn the indicated adjustment knob counterclockwise two or three turns to loosen it (if the knob is not loosened enough, it may scratch the rail). Next, pull the knob, slide the seat carriage to the desired position, and then release the knob. **Move the seat carriage back and forth slightly until it locks into position.** Then, turn the knob clockwise until it is tight.

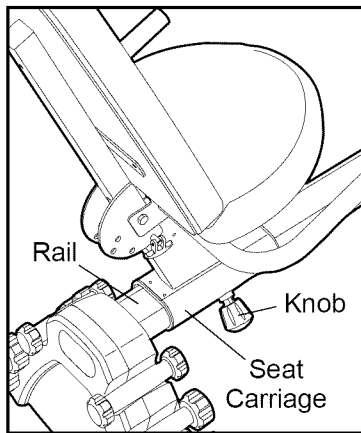

HOW TO ADJUST THE UPRIGHT

The upright can be adjusted to the height that is the most comfortable for you. To adjust the upright, first turn the indicated adjustment knob counterclockwise two or three turns to loosen it (if the knob is not loosened enough, it may scratch the upright). Next, pull the knob, slide the upright to the desired height, and then release the knob. **Move the upright up and down slightly until it locks into position.** Then, turn the knob clockwise until it is tight. **IMPORTANT: After you adjust the upright, make sure that your knees will not touch the handgrip pulse sensor when you pedal.**

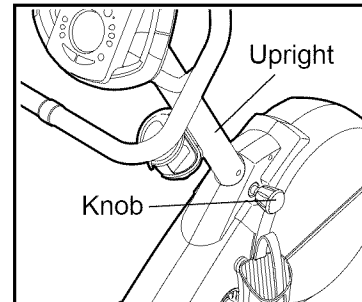

HOW TO ADJUST THE PEDAL STRAPS

To adjust the pedal straps, first pull the ends of the straps off the tabs on the pedals. Adjust the straps to the desired positions, and then press the ends of the straps back onto the tabs.

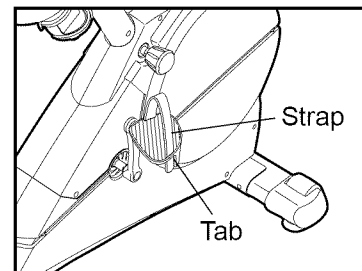

HOW TO USE THE HAND WEIGHTS

The included hand weights can be used for a variety of strength training exercises with the weight bench (see page 20). In addition, the hand weights can be used with the recumbent cycle. As you pedal, press the hand weights over your head, raise the hand weights out to your sides until your hands are level with your shoulders, or do arm curls with the hand weights.

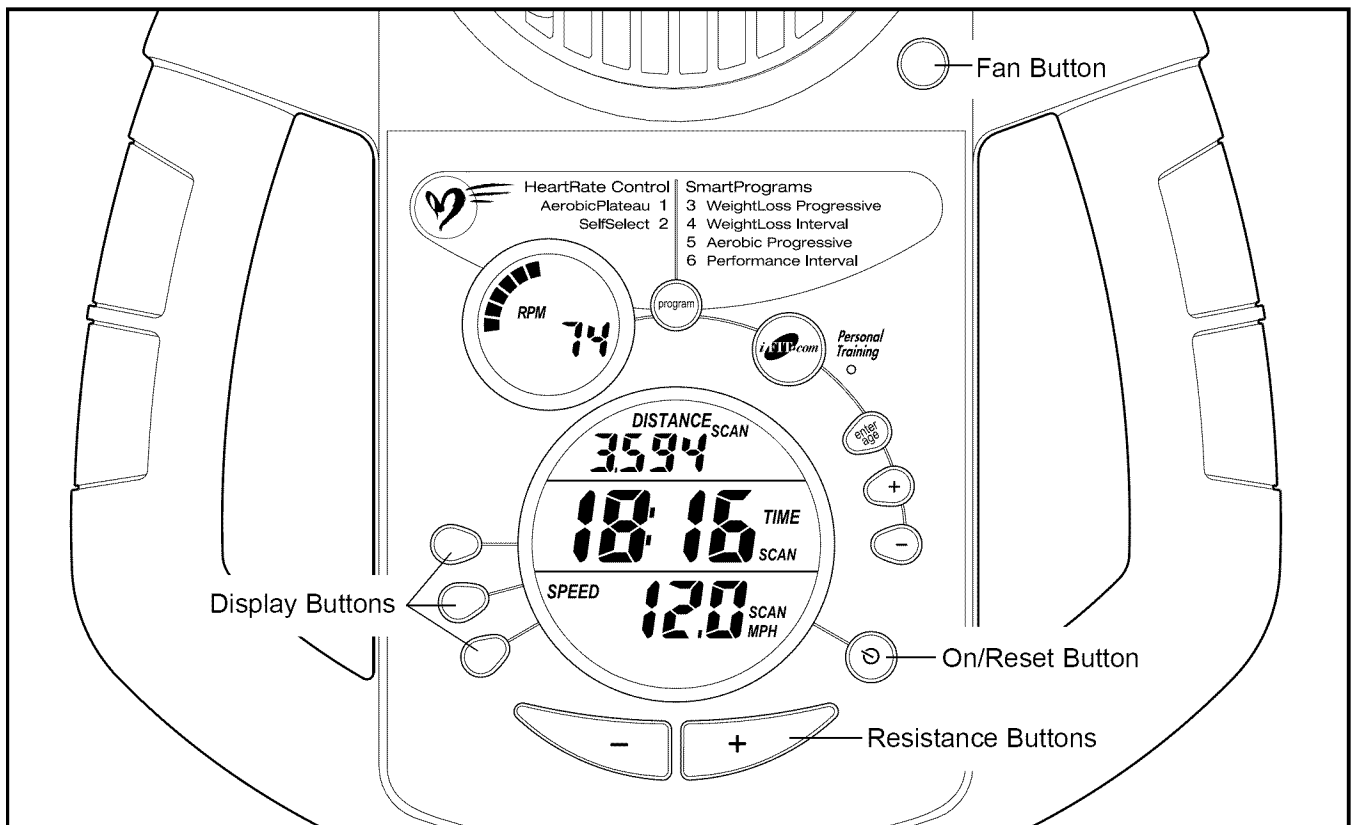

FEATURES OF THE CONSOLE

The advanced console offers a selection of features designed to make your workouts more enjoyable and effective. When the manual mode of the console is selected, the resistance of the pedals can be changed with the touch of a button. As you pedal, the console will provide continuous exercise feedback. You can even measure your heart rate using the built-in hand-grip pulse sensor.

The console also offers four Smart programs. Each program automatically changes the resistance of the pedals and prompts you to increase or decrease your pace as it guides you through an effective workout.

In addition, the console features two Heart Rate programs that change the resistance of the pedals and prompt you to vary your pace to keep your heart rate near a target heart rate as you exercise.

The console also features iFIT.com interactive technology. Having iFIT.com technology is like having a per-

sonal trainer in your home. Using a stereo audio cable (available at electronics stores), you can connect the crosstrainer to your home stereo, portable stereo, computer, or VCR and play special iFIT.com CD and video programs (iFIT.com CDs and videocassettes are available separately). iFIT.com CD and video programs automatically control the resistance of the pedals and prompt you to vary your pace as a personal trainer coaches you through every step of your workout. High-energy music provides added motivation. **To purchase iFIT.com CDs and videocassettes, call toll-free 1-800-735-0768.**

With the crosstrainer connected to your computer, you can also go to our Web site at www.iFIT.com and access programs directly from the internet. **Explore www.iFIT.com for more information.**

To use the manual mode of the console, see page 10. To use a Smart program, see page 12. To use a Heart Rate program, see page 13. To use an iFIT.com CD or videocassette, see page 17. To use a program directly from our Web site, see page 18.

HOW TO USE THE MANUAL MODE

1 Turn on the console.

Note: The console requires four 1.5V “D” batteries (see assembly step 10 on page 7).

To turn on the console, press the On/Reset button or begin pedaling. (See the drawing on page 9 to identify the On/Reset button.)

2 Select the manual mode.

Each time the console is turned on, the manual mode will be selected. If a program has been selected, select the manual mode by pressing the Program button repeatedly until the letters RPM appear in the small display.

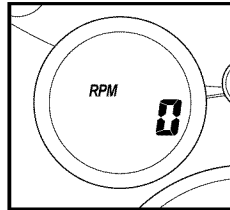

3 Begin pedaling and change the resistance of the pedals as desired.

As you pedal, change the resistance of the pedals by pressing the + and – buttons below the large display. There are ten resistance levels—level 10 is the most challenging. Note: After the buttons are pressed, it will take a few seconds for the resistance to reach the selected setting.

4 Follow your progress with small display and the large display.

The small display will show your pedaling pace, in revolutions per minute (RPM). The indicator bar in the small display will increase or decrease in length as you increase or decrease your pedaling pace.

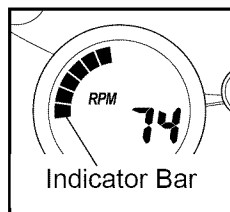

The upper section of the large display will show the distance you have pedaled

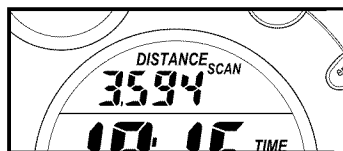

and the numbers of *calories* and *fat calories* you have burned (see FAT BURNING on page 19 for an explanation of fat calories). The display will change from one number to the next every few

seconds. If you use the handgrip pulse sensor, the display will also show your heart rate (see step 5 on page 11).

To view only the distance you have pedaled or the number of calories or fat calories you have burned, press the upper button on the left side of the large display until only the word DISTANCE, CALORIES, or FAT CALORIES appears in the upper section of the large display. Make sure that the word SCAN does not appear. To again view the distance you have pedaled and the numbers of calories and fat calories you have burned, press the upper button until the word SCAN reappears.

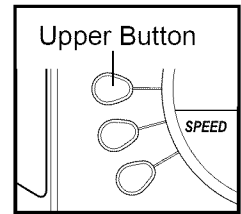

The center of the large display will show the elapsed time and your current pace (pace is shown in minutes per mile). The display will change from one number to the other every few seconds.

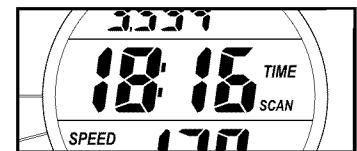

Note: When a program is selected (except for the SelfSelect program), the display will show the time *remaining* in the program instead of the elapsed time.

To view only the elapsed time or your pace, press the center button on the left side of the large display until only the word TIME or PACE appears. Make sure that the word SCAN does not appear. To view both the elapsed time and your pace, press the center button until the word SCAN reappears.

The lower section of the large display will show your pedaling speed and the resistance level.

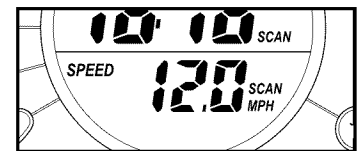

The display will change from one number to the other every few seconds.

To view only your pedaling speed or the resistance level, press the lower button on the left side of the large display until only the word SPEED or RESISTANCE appears. Make sure that the word SCAN does not appear. To view both your pedaling speed and the resistance level, press the lower button until the word SCAN reappears.

To reset the displays, press the On/Reset button.

Note: The console can show speed and distance in either miles or kilometers. The letters MPH or KM/H will appear in the lower section of the large display to show which system of measurement is selected. To change the system of measurement, hold down the On/Reset button for about six seconds. Note: When the button is held down, the fan will turn on for a moment. When the batteries are replaced, it may be necessary to reselect the desired system of measurement.

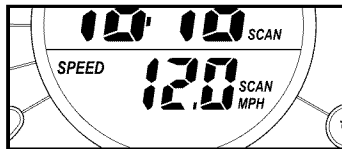

5 Measure your heart rate if desired.

If there are thin sheets of plastic on the metal contacts on the handgrips, peel off the plastic. To use the handgrip pulse sensor, hold the handgrips with your palms resting against the metal contacts. **Avoid moving your hands.** When your pulse is detected, the heart-shaped indicator in the large display will flash each time your heart beats. After a moment, two dashes (--) will appear and then your heart rate will be shown.

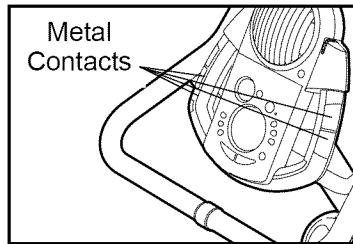

For the most accurate heart rate reading, continue to hold the handgrips for about 30 seconds. Note: When you first hold the handgrips, the large display will show your heart rate continuously for 30 seconds. The display will then show your heart rate along with other feedback modes.

6 Turn on the fan if desired.

To turn on the fan at low speed, press the fan button. To turn on the fan at high speed, press the fan button a second time. To turn off the fan, press the fan button a third time. Note: If the pedals are not moved for about thirty seconds, the fan will automatically turn off.

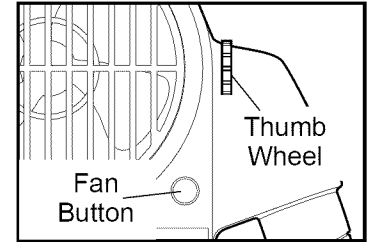

Rotate the thumb wheel on the right side of the console to pivot the fan to the desired angle.

7 When you are finished exercising, the console will automatically turn off.

If the pedals are not moved for a few seconds, the displays will pause and the time will flash in the large display.

If the pedals are not moved and the console buttons are not pressed for a few minutes, the console will turn off to conserve the batteries.

HOW TO USE A SMART PROGRAM

Each Smart program will automatically change the resistance of the pedals and prompt you to increase or decrease your pace as it guides you through an effective workout. Programs 3 and 4 are weight loss programs, program 5 is an aerobic program, and program 6 is a high-performance interval-training program.

Follow the steps below to use a Smart program.

1 Turn on the console.

See step 1 on page 10.

2 Select one of the Smart programs.

Each time the console is turned on, the manual mode will be selected. To select a Smart program, press the Program button repeatedly until the number 3, 4, 5, or 6 appears in the small display.

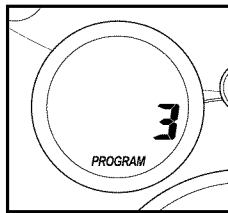

3 Begin pedaling to start the program.

To start the program, simply begin pedaling. Each Smart program consists of 20 or 30 one-minute periods. One resistance level and one target pace are programmed for each period. (The same resistance level and/or target pace may be programmed for two or more consecutive periods.)

At the end of each period of the program, the resistance of the pedals will automatically change if a different resistance level is programmed for the next period. Note: If the resistance level is too high or too low, you can change it by pressing the + and – buttons below the large display. However, when the current period is completed, the resistance of the pedals will automatically change if a different resistance level is programmed for the next period.

The target pace for the current period will be shown by the arrows in the small display. To pedal at the target pace, simply

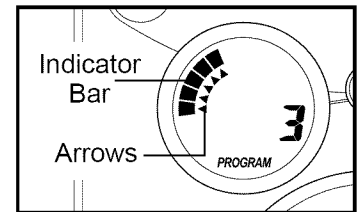

increase or decrease your pace until there is one arrow pointing to each segment of the indicator bar (see the drawing above). At the end of each period, the number of arrows will change if a different target pace is programmed for the next period. When the number of arrows changes, change your pace until there is one arrow pointing to each segment of the indicator bar.

Important: The target pace is intended only to provide a goal. Your actual pace may be slower than the target pace, especially during the first few months of your exercise program. Make sure to pedal at a pace that is comfortable for you.

During the program, the center of the large display will show the time remaining in the program. If you stop pedaling for a few seconds, the displays will pause and the time will flash. If you continue pedaling after the program is completed, the displays will continue to show exercise feedback.

4 Follow your progress with the large display.

See step 4 on page 10.

5 Measure your heart rate if desired.

See step 5 on page 11.

6 Turn on the fan if desired.

See step 6 on page 11.

7 When you are finished exercising, the console will automatically turn off.

See step 7 on page 11.

HOW TO USE A HEART RATE PROGRAM

Heart Rate program 1 is designed to keep your heart rate between 65% and 85% of your *maximum heart rate* during your workout. (Your maximum heart rate is estimated by subtracting your age from 220. For example, if you are 25 years old, your maximum heart rate is 195 beats per minute.) Heart Rate program 2 is designed to keep your heart rate near a target heart rate that you select.

Follow the steps below to use a Heart Rate program.

1 Turn on the console.

See step 1 on page 10.

2 Select one of the Heart Rate programs.

Each time the console is turned on, the manual mode will be selected. To select a Heart Rate program, press the Program button repeatedly until the number 1 or 2 appears in the small display.

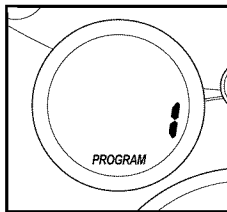

3 Enter your age or a target heart rate.

If program 1 is selected, the word AGE will appear in the large display and the current age setting will flash. If you have already entered your age, press the Enter button. If you have not entered your age, press the small + and – buttons to enter your age. Then, press the Enter button. Once you have entered your age, it will be saved in memory until the batteries are replaced.

If program 2 is selected, the letters PLS (pulse) will appear in the large display and the current target heart rate will flash. If you do not wish to change the target heart rate, press the Enter button. If you wish to change the target heart rate, press the small + and – buttons. Then, press the Enter button. The target heart rate can be from 70 to 170 beats per minute.

4 Hold the handgrip pulse sensor.

It is not necessary to hold the handgrips continuously during a Heart Rate program; however, you must hold the handgrips frequently for the program

to operate properly. **Each time you hold the handgrips, keep your hands on the metal contacts for at least 30 seconds.** Note: When you are not holding the handgrips, the letters PLS will appear in the large display instead of your heart rate.

5 Begin pedaling to start the program.

To start the program, simply begin pedaling.

Program 1 consists of 20 one-minute periods. One resistance level and one target heart rate are programmed for each period. (The same resistance level and/or target heart rate may be programmed for two or more consecutive periods.)

Program 2 is sixty minutes long (you may choose to use only part of the program). The same resistance level and target heart rate are programmed for the entire program.

If program 1 is selected, the resistance of the pedals will periodically change. (Note: If the resistance level is too high or too low, you can change it by pressing the + and – buttons below the large display. However, when the current period is completed, the resistance of the pedals may automatically change.) If program 2 is selected, the resistance of the pedals will not change. Note: You can change the resistance level for the entire program by pressing the + and – buttons below the large display if desired.

During programs

1 and 2, the arrows in the small display will help you to keep your heart rate near the current target heart rate.

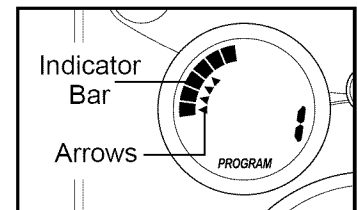

When you hold the handgrip pulse sensor, the console will compare your heart rate to the current target heart rate. If your heart rate is too far above or below the target heart rate, the number of arrows in the small display will change to prompt you to increase or decrease your pace. When the number of arrows changes, change your pace until there is one arrow pointing to each segment of the indicator bar. **Important: The target pace is intended only to provide a goal. Your actual pace may be slower than the target pace, especially during the first few months of your exercise program. Make sure to pedal at a pace that is comfortable for you.**

Note: If you stop pedaling for a few seconds, the program will end. To use the program again, reselect it and start it at the beginning.

6 Follow your progress with the large display.

See step 4 on page 10.

7 Turn on the fan if desired.

See step 6 on page 11.

8 When you are finished exercising, the console will automatically turn off.

See step 7 on page 11.

HOW TO CONNECT YOUR CD PLAYER, VCR, OR COMPUTER

To use **iFIT.com CDs**, the crosstrainer must be connected to your portable CD player, portable stereo, home stereo, or computer with CD player. See pages 14 to 16 for connecting instructions. To use **iFIT.com videocassettes**, the crosstrainer must be connected to your VCR. See page 16 for connecting instructions. To use **iFIT.com programs directly from our Web site**, the crosstrainer must be connected to your computer. See page 16 for connecting instructions.

HOW TO CONNECT YOUR PORTABLE CD PLAYER

Note: If your CD player has separate LINE OUT and PHONES jacks, see instruction A below. If your CD player has only one jack, see instruction B.

- A. Plug one end of a 1/8" to 1/8" stereo audio cable (available at electronics stores) into the jack beneath the console. Plug the other end of the cable into the LINE OUT jack on your CD player. Plug your headphones into the PHONES jack.

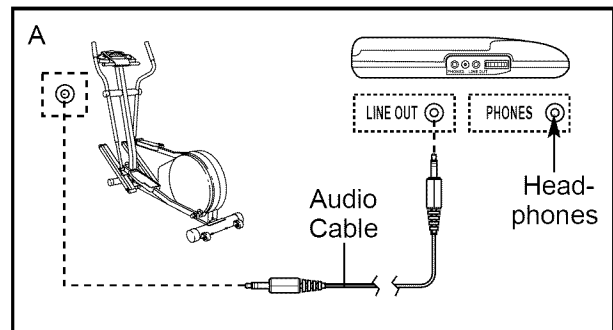

- B. Plug one end of a 1/8" to 1/8" stereo audio cable (available at electronics stores) into the jack beneath the console. Plug the other end of the cable into a 1/8" Y-adapter (available at electronics stores). Plug the Y-adapter into the PHONES jack on your CD player. Plug your headphones into the other side of the Y-adapter.

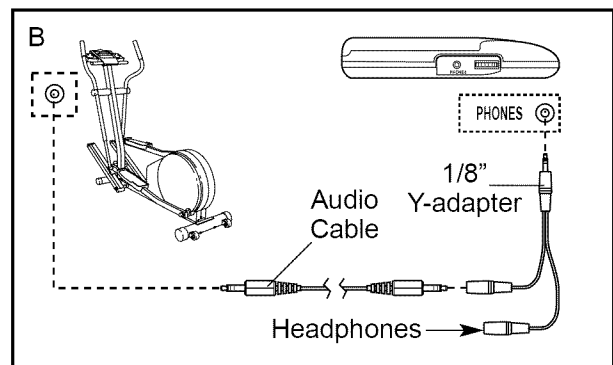

HOW TO CONNECT YOUR PORTABLE STEREO

Note: If your stereo has an RCA-type AUDIO OUT jack, see instruction A below. If your stereo has a 1/8" LINE OUT jack, see instruction B. If your stereo has only a PHONES jack, see instruction C.

- A. Plug one end of a 1/8" to RCA stereo audio cable (available at electronics stores) into the jack beneath the console. Plug the other end of the cable into the AUDIO OUT jack on your stereo.

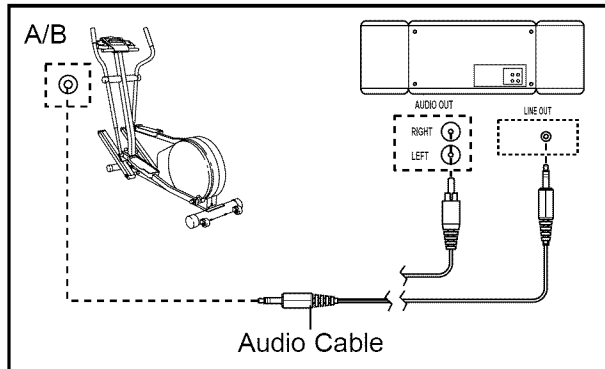

- B. See the drawing above. Plug one end of a 1/8" to 1/8" stereo audio cable (available at electronics stores) into the jack beneath the console. Plug the other end of the cable into the LINE OUT jack on your stereo.

- C. Plug one end of a 1/8" to 1/8" stereo audio cable (available at electronics stores) into the jack beneath the console. Plug the other end of the cable into a 1/8" Y-adapter (available at electronics stores). Plug the Y-adapter into the PHONES jack on your stereo. Plug your headphones into the other side of the Y-adapter.

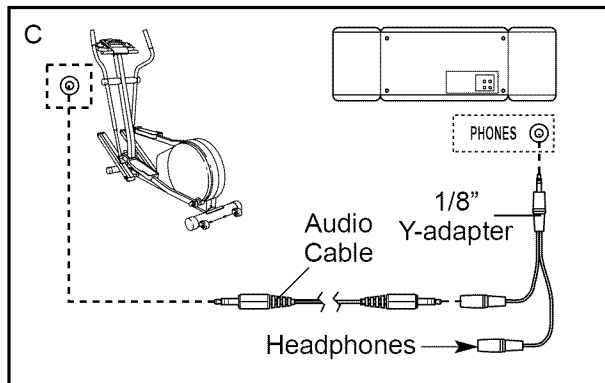

HOW TO CONNECT YOUR HOME STEREO

Note: If your stereo has an unused LINE OUT jack, see instruction A below. If the LINE OUT jack is being used, see instruction B.

- A. Plug one end of a 1/8" to RCA stereo audio cable (available at electronics stores) into the jack beneath the console. Plug the other end of the cable into the LINE OUT jack on your stereo.

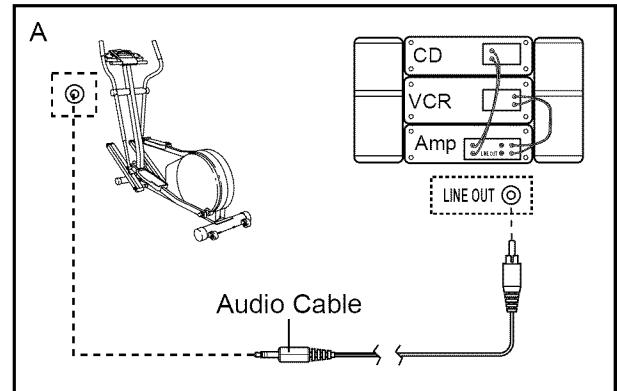

- B. Plug one end of a 1/8" to RCA stereo audio cable (available at electronics stores) into the jack beneath the console. Plug the other end of the cable into an RCA Y-adapter (available at electronics stores). Next, remove the wire that is currently plugged into the LINE OUT jack on your stereo and plug the wire into the unused side of the Y-adapter. Plug the Y-adapter into the LINE OUT jack on your stereo.

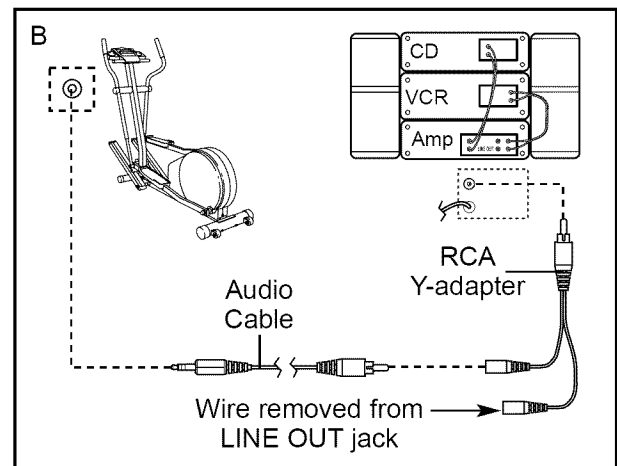

HOW TO CONNECT YOUR COMPUTER

Note: If your computer has a 1/8" LINE OUT jack, see instruction A. If your computer has only a PHONES jack, see instruction B.

- A. Plug one end of a 1/8" to 1/8" stereo audio cable (available at electronics stores) into the jack beneath the console. Plug the other end of the cable into the LINE OUT jack on your computer.

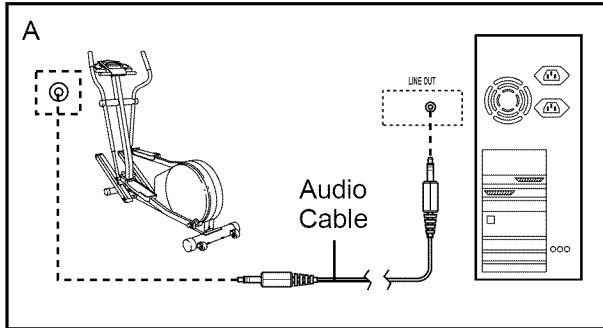

- B. Plug one end of a 1/8" to 1/8" stereo audio cable (available at electronics stores) into the jack beneath the console. Plug the other end of the cable into a 1/8" Y-adapter (available at electronics stores). Plug the Y-adapter into the PHONES jack on your computer. Plug your headphones or speakers into the other side of the Y-adapter.

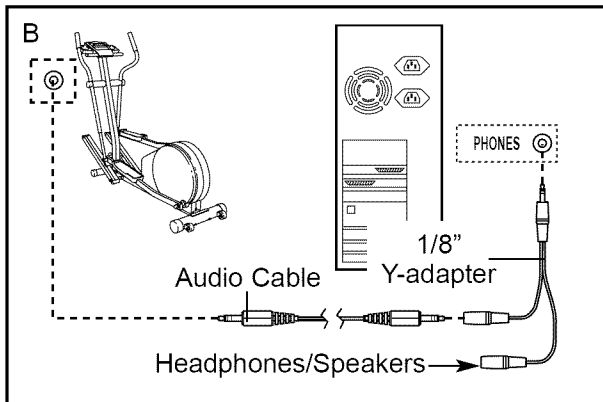

HOW TO CONNECT YOUR VCR

Note: If your VCR has an unused AUDIO OUT jack, see instruction A below. If the AUDIO OUT jack is being used, see instruction B. If you have a TV with a built-in VCR, see instruction B. If your VCR is connected to your home stereo, see HOW TO CONNECT YOUR HOME STEREO on page 15.

- A. Plug one end of a 1/8" to RCA stereo audio cable (available at electronics stores) into the jack beneath the console. Plug the other end of the cable into the AUDIO OUT jack on your VCR.

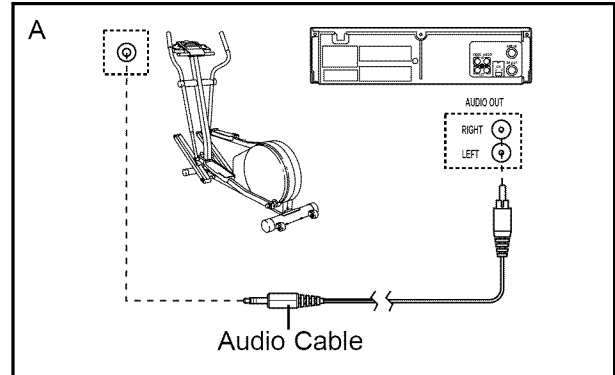

- B. Plug one end of a 1/8" to RCA stereo audio cable (available at electronics stores) into the jack beneath the console. Plug the other end of the cable into an RCA Y-adapter (available at electronics stores). Next, remove the wire that is currently plugged into the AUDIO OUT jack on your VCR and plug the wire into the unused side of the Y-adapter. Plug the Y-adapter into the AUDIO OUT jack on your VCR.

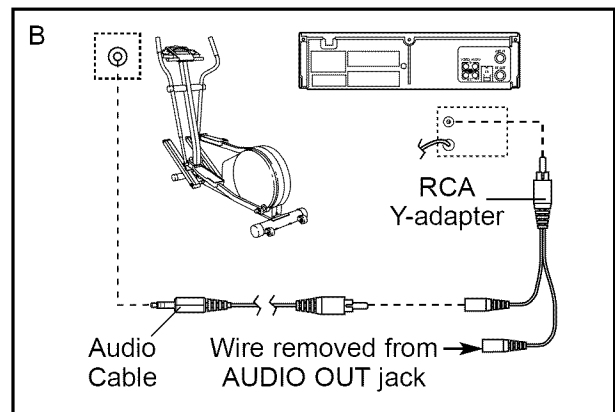

HOW TO USE iFIT.COM CD AND VIDEO PROGRAMS

To use iFIT.com CDs or videocassettes, the crosstrainer must be connected to your portable CD player, portable stereo, home stereo, computer with CD player, or VCR. See HOW TO CONNECT YOUR CD PLAYER, VCR, OR COMPUTER on page 14. To purchase iFIT.com CDs and videocassettes, call toll-free 1-800-735-0768.

Follow the steps below to use an iFIT.com CD or video program.

1 Turn on the console.

See step 1 on page 10.

2 Select the iFIT.com mode.

Each time the console is turned on, the manual mode will be selected. To select the iFIT.com mode, press the iFIT.com button. The indicator near the button will light and the letters IF will appear in the small display.

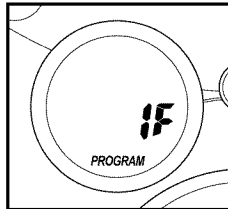

3 Insert the iFIT.com CD or videocassette.

If you are using an iFIT.com CD, insert the CD into your CD player. If you are using an iFIT.com videocassette, insert the videocassette into your VCR.

4 Press the play button on your CD player or VCR.

A moment after the play button is pressed, your personal trainer will begin guiding you through your workout. Simply follow your personal trainer's instructions.

The program will function in almost the same way as a Smart program (see step 3 on page 12). However, an electronic "chirping" sound will alert you when the resistance level and/or the target pace is about to change.

Note: If the resistance of the pedals and/or the target pace does not change when a "chirp" is heard:

- Make sure that the indicator near the iFIT.com button is lit.
- Adjust the volume of your CD player or VCR. If the volume is too high or too low, the console may not detect the program signals.
- Make sure that the audio cable is properly connected and that it is fully plugged in.

5 Follow your progress with the large display.

See step 4 on page 10.

6 Measure your heart rate if desired.

See step 5 on page 11.

7 Turn on the fan if desired.

See step 6 on page 11.

8 When you are finished exercising, the console will automatically turn off.

See step 7 on page 11.

HOW TO USE PROGRAMS DIRECTLY FROM OUR WEB SITE

Our Web site at www.iFIT.com allows you to play iFIT.com programs directly from the internet. To use programs from our Web site, the crosstrainer must be connected to your computer. See HOW TO CONNECT YOUR COMPUTER on page 16. In addition, you must have an internet connection and an internet service provider. A list of specific system requirements will be found on our Web site.

Follow the steps below to use a program from our Web site.

1 Turn on the console.

See step 1 on page 10.

2 Select the iFIT.com mode.

Each time the console is turned on, the manual mode will be selected. To select the iFIT.com mode, press the iFIT.com button. The indicator near the button will light and the letters IF will appear in the small display.

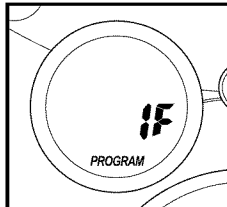

3 Go to your computer and start an internet connection.

4 Start your Web browser, if necessary, and go to our Web site at www.iFIT.com.

5 Follow the desired links on our Web site to select a program.

6 Follow the on-line instructions to start the program.

When you start the program, an on-screen countdown will begin.

7 Return to the crosstrainer and begin pedaling.

When the on-screen countdown ends, the program will begin. The program will function in almost the same way as a Smart program (see step 3 on page 12). However, an electronic “chirping” sound will alert you when the resistance level and/or the target pace is about to change.

8 Follow your progress with the large display.

See step 4 on page 10.

9 Measure your heart rate if desired.

See step 5 on page 11.

10 When you are finished exercising, the console will automatically turn off.

See step 7 on page 11.

RECUMBENT CYCLE EXERCISE GUIDELINES

⚠ WARNING:

Before beginning this or any exercise program, consult your physician. This is especially important for persons over the age of 35 or persons with pre-existing health problems.

The pulse sensor is not a medical device. Various factors may affect the accuracy of heart rate readings. The pulse sensor is intended only as an exercise aid in determining heart rate trends in general.

The following guidelines will help you to plan your workouts using the recumbent cycle. Remember that proper nutrition and adequate rest are essential for successful results.

EXERCISE INTENSITY

Whether your goal is to burn fat or to strengthen your cardiovascular system, the key to achieving the desired results is to exercise with the proper intensity. The proper intensity level can be found by using your heart rate as a guide. The chart below shows recommended heart rates for fat burning, maximum fat burning, and cardiovascular (aerobic) exercise.

165	155	145	140	130	125	115	♥
145	138	130	125	118	110	103	♥
125	120	115	110	105	95	90	♥
20	30	40	50	60	70	80	

To find the proper heart rate for you, first find your age on the bottom line of the chart (ages are rounded off to the nearest ten years). Next, find the three numbers above your age. The three numbers are your “training zone.” The lower two numbers are recommended heart rates for fat burning; the highest number is the recommended heart rate for aerobic exercise.

Fat Burning

To burn fat effectively, you must exercise at a relatively low intensity level for a sustained period of time. During the first few minutes of exercise, your body uses easily accessible *carbohydrate* calories for energy. Only after the first few minutes of exercise does

your body begin to use stored *fat* calories for energy. If your goal is to burn fat, adjust the intensity of your exercise until your heart rate is near the lowest number in your training zone as you exercise. For maximum fat burning, adjust the intensity of your exercise until your heart rate is near the middle number in your training zone as you exercise.

Aerobic Exercise

If your goal is to strengthen your cardiovascular system, your exercise must be “aerobic.” Aerobic exercise is activity that requires large amounts of oxygen for prolonged periods of time. This increases the demand on the heart to pump blood to the muscles, and on the lungs to oxygenate the blood. For aerobic exercise, adjust the intensity of your exercise until your heart rate is near the highest number in your training zone as you exercise.

WORKOUT GUIDELINES

Each workout should include the following three parts:

A warm-up, consisting of 5 to 10 minutes of stretching and light exercise. A proper warm-up increases your body temperature, heart rate, and circulation in preparation for exercise.

Training zone exercise, consisting of 20 to 30 minutes of exercising with your heart rate in your training zone. (During the first few weeks of your exercise program, do not keep your heart rate in your training zone for longer than 20 minutes.)

A cool-down, with 5 to 10 minutes of stretching. This will increase the flexibility of your muscles and will help to prevent post-exercise problems.

EXERCISE FREQUENCY

To maintain or improve your condition, plan three workouts on the recumbent cycle each week. After a few months of regular exercise, you may complete up to five workouts each week if desired. Note: You may wish to use the recumbent cycle and the weight bench on alternating days. For example, plan aerobic workouts on Monday, Wednesday, and Friday, and plan weight training workouts on Tuesday, Thursday, and Saturday. Make sure to rest for at least one full day each week to give your body time to regenerate.

CAUTION: It is very important to avoid overdoing it during the first few months of your exercise program, and to progress at your own pace.

WEIGHT BENCH EXERCISE GUIDELINES

⚠ WARNING: Before beginning any exercise program, consult your physician. This is especially important for persons over the age of 35 or persons with pre-existing health problems.

HOW TO ADJUST THE BACKREST

The backrest can be adjusted to any of four positions: the inclined (upright) position, the semi-inclined position, the flat position, and the declined position.

To adjust the backrest, **first adjust the seat to the farthest forward position** (see HOW TO ADJUST THE SEAT on page 8). Next, pull out the adjustment pin. Pivot the backrest to the desired position, and then insert the pin into one of the holes in the rounded brackets and the corresponding hole in the seat carriage (see the inset drawing). Note: When the backrest is in the declined position, the seat will also be declined. **CAUTION: Never sit on the backrest or the headrest; doing so could cause the crosstrainer to tip, resulting in injury.**

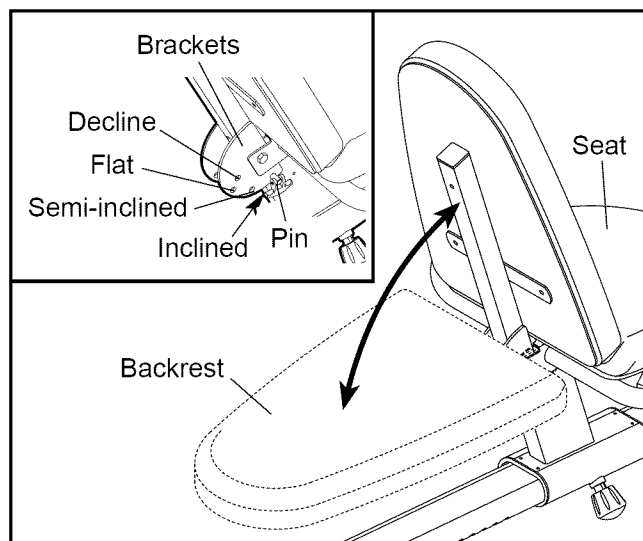

STRENGTH TRAINING GUIDELINES

The weight bench can be used for a variety of exercises designed to trim, tone, and strengthen the body. Please read these guidelines before using the weight bench.

It is recommended that your strength training program include 3 workouts each week. Note: You may wish to use the weight bench and the recumbent cycle on

alternating days. For example, plan weight training workouts on Tuesday, Thursday, and Saturday, and plan aerobic workouts on Monday, Wednesday, and Friday. Make sure to rest for at least one full day each week to give your body time to regenerate. **CAUTION: It is very important to avoid overdoing it during the first few months of your exercise program, and to progress at your own pace.**

Begin each workout with five to eight minutes of stretching and light exercise to warm up. A proper warm-up increases your body temperature, heart rate, and circulation in preparation for exercise.

After warming up, perform a selection of weight training exercises. The chart on the backrest shows four exercises that can be performed. Consult a reputable book to find other exercises that can be performed using hand weights and a weight bench. To give balance to your workouts, vary the exercises from workout to workout. Begin with 1 set of 12 repetitions for each exercise. (A "repetition" is one complete cycle of an exercise, such as one sit-up. A "set" is a series of repetitions performed without a pause.) As your fitness level increases, perform 2 or 3 sets for each exercise. Always rest for at least 1 minute after each set. When you can complete 3 sets of 12 repetitions without difficulty, you may choose to use heavier weights.

CAUTION: The crosstrainer includes three pairs of hand weights. Do not use other weights with the crosstrainer.

Finish each workout with five to eight minutes of stretching to cool down. This will increase your flexibility and will help to prevent soreness.

EXERCISE FORM

For the best results, correct form is important. Maintaining proper form means moving through the full range of motion for each exercise, and moving only the appropriate parts of the body. Make sure to perform each exercise with a smooth, steady motion. Exhale as you exert yourself, and inhale as you return to the starting position; never hold your breath.

STAYING MOTIVATED

For motivation, try listening to music or watching television while you exercise. Use a calendar to keep a record of your workouts, and record key body measurements at the end of every month. Remember, the key to lasting results is to make exercise a regular and enjoyable part of your daily life.

MAINTENANCE AND TROUBLESHOOTING

Inspect and tighten all parts of the crosstrainer regularly. Replace any worn parts immediately.

To clean the crosstrainer, use a damp cloth and a small amount of mild soap. **Important: To avoid damage to the console, keep liquids away from the console and keep the console out of direct sunlight.**

BATTERY REPLACEMENT

If the console display becomes dim, the batteries should be replaced; most console problems are the result of low batteries. See assembly step 10 on page 7 for replacement instructions. Note: The console requires four “D” batteries.

HOW TO LEVEL THE CROSSTRAINER

After the crosstrainer has been moved to the location where it will be used, make sure that both ends of front stabilizer are touching the floor. If the crosstrainer rocks slightly during use, turn one or both of the feet under the front stabilizer until the rocking motion is eliminated.

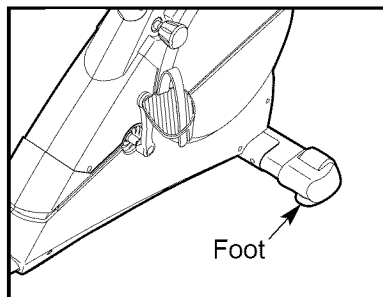

HANDGRIP PULSE SENSOR TROUBLESHOOTING

• Avoid moving your hands while using the handgrip pulse sensor. Excessive movement may interfere with heart rate readings.

- Do not hold the metal contacts too tightly; doing so may interfere with heart rate readings.
- For the most accurate heart rate reading, hold the metal contacts for about 15 seconds.
- For optimal performance of the handgrip pulse sensor, keep the metal contacts clean. The contacts can be cleaned with a soft cloth—**never use alcohol, abrasives, or chemicals.**

HOW TO MOVE THE CROSSTRAINER

Before moving the crosstrainer, remove the hand weights and adjust the seat to the position shown in the drawing below. Then, stand behind the crosstrainer, hold the rail in the indicated location, and lift the rail until the crosstrainer can be moved on the front wheels. Carefully move the crosstrainer to the desired location and then lower it. **CAUTION: To decrease the possibility of injury, bend your legs and keep your back straight as you lift the rail and move the crosstrainer; make sure to lift with your legs rather than your back.**

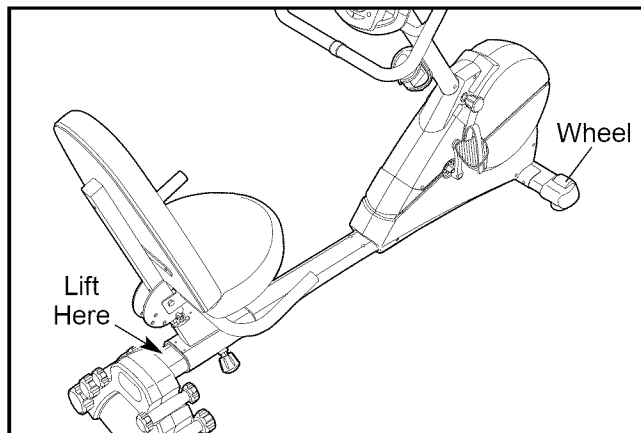

PART LIST—Model No. PFE39931

R0903A

Key No.	Qty.	Description	Key No.	Qty.	Description
1	1	Frame	50	1	Backrest Frame Endcap
2	1	Front Stabilizer	51	1	1/2" x 70mm Button Bolt
3	1	Frame Extension	52	1	1/2" Nylon Locknut
4	1	Seat Carriage	53	1	Belt
5	1	Backrest Frame	54	1	Pulley/Crank
6	1	Seat Frame	55	1	M6 x 25mm Bolt
7	1	Rear Stabilizer Cover	56	2	Flange Screw
8	1	Front Stabilizer Cover	57	1	Right Crank Arm
9	1	Rear Stabilizer	58	2	M6 Eyebolt
10	1	Backrest	59	1	"U" Bracket
11	1	Left Handlebar	60	4	M6 Nut
12	1	Seat	61	5	M8 Nylon Locknut
13	1	Upright	62	2	Flywheel Washer
14	1	Upright Bushing	63	2	M10 Black Nylon Locknut
15	1	Right Handlebar	64	7	M6 x 16mm Screw
16	1	Console	65	2	M10 x 112mm Carriage Bolt
17	1	Left Side Shield	66	2	M10 Zinc Nylon Locknut
18	1	Right Side Shield	67	1	"C" Magnet Bracket
19	1	Side Shield Cover	68	2	M10 x 52mm Zinc Button Bolt
20	2	Seat Carriage Bushing	69	1	M6 x 50mm Screw
21	2	Small Hand Weight	70	8	M5 x 7mm Screw
22	2	Medium Hand Weight	71	1	M6 Flat Washer
23	2	Large Hand Weight	72	5	M4 x 25mm Screw
24	1	Left Pedal	73	12	M4 x 16mm Screw
25	1	Left Pedal Strap	74	2	M10 x 45mm Button Screw
26	1	Right Pedal	75	4	M4 x 38mm Round Head Screw
27	1	Right Pedal Strap	76	2	M8 x 39mm Button Bolt
28	2	Adjustment Knob	77	2	Handlebar Collar
29	1	Adjustment Pin	78	2	M5 Nut
30	2	Wheel	79	1	M6 x 25.4mm Button Screw
31	1	Left Front Endcap	80	2	M6 x 72mm Button Screw
32	1	Right Front Endcap	81	4	M5 x 12mm Bolt
33	2	Foot	82	1	Reed Switch Clamp
34	1	Adjustment Motor	83	4	M5 Nylon Locknut
35	1	Upper Wire Harness	84	2	M4 x 12mm Round Head Screw
36	1	Lower Wire Harness	85	2	M10 Zinc Split Washer
37	1	Flywheel	86	2	Foam Grip
38	1	Magnet	87	1	M6 Large Washer
39	1	Flywheel Axle	88	1	M8 x 14mm Button Screw
40	2	Flywheel Bearing	89	1	Water Bottle Holder
41	1	"C" Magnet	90	2	Handlebar Foam
42	1	Left Crank Arm	91	2	M4 x 22mm Screw
43	1	Reed Switch/Wire	92	1	M4 x 8mm Screw
44	1	Crank Bearing Assembly	93	2	Seat Frame Endcap
45	4	M5 Flat Washer	94	4	M8 x 12mm Button Screw
46	1	Adjustment Cable	95	1	Handlebar Bracket
47	1	Return Spring	#	1	User's Manual
48	2	M6 Nylon Locknut	#	3	Allen Wrench
49	2	Seat Bushing			

Note: "#" indicates a non-illustrated part. Specifications are subject to change without notice. See the back cover of this manual for information about ordering replacement parts.

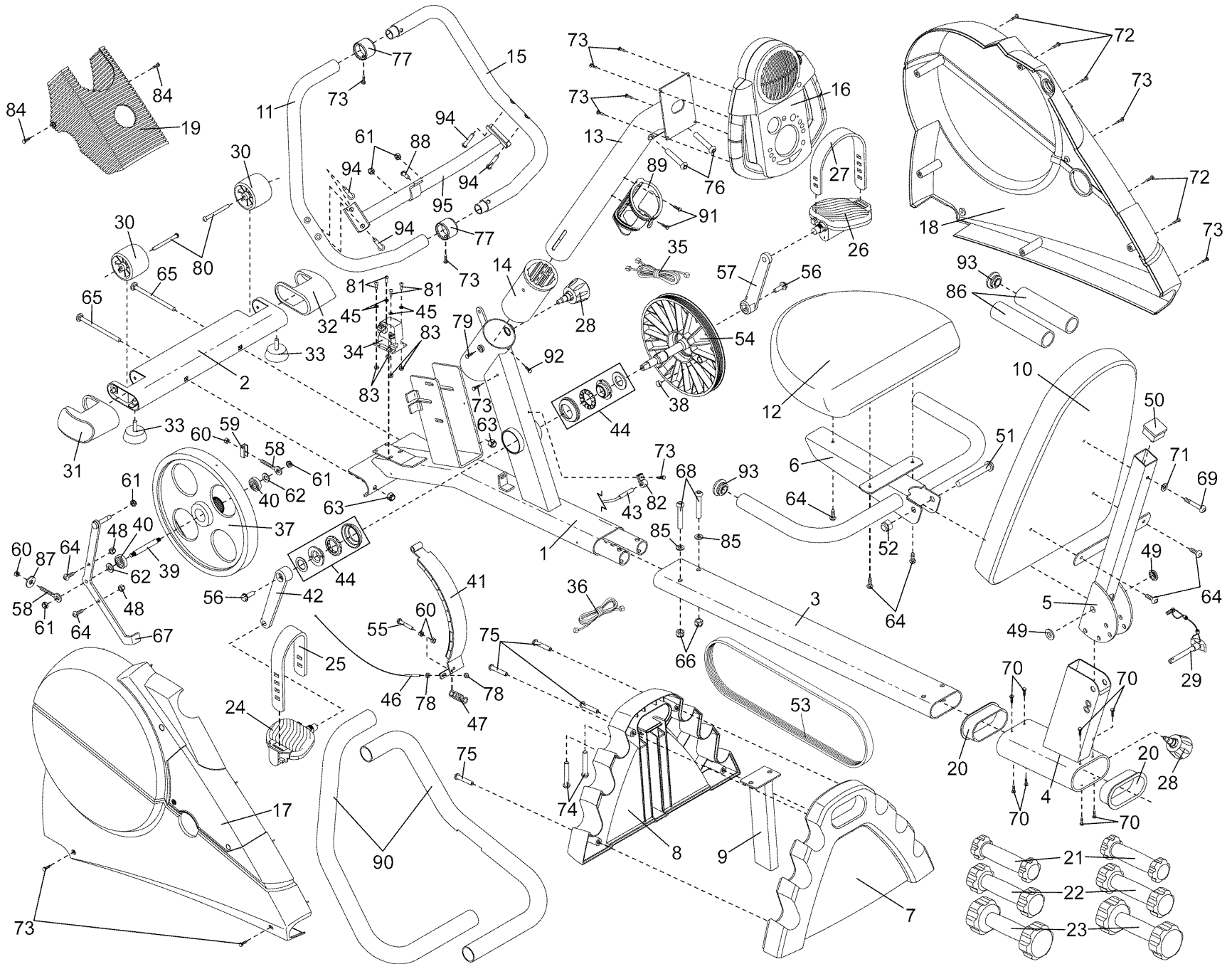

HOW TO ORDER REPLACEMENT PARTS

To order replacement parts, call our Customer Service Department toll-free at 1-800-999-3756, Monday through Friday, 6 a.m. until 6 p.m. Mountain Time (excluding holidays). To help us assist you, please be prepared to give the following information:

- The MODEL NUMBER of the product (PFEX39931)
- The NAME of the product (PROFORM® CROSSTRAINER 56)
- The SERIAL NUMBER of the product (see the front cover of this manual)
- The KEY NUMBER and DESCRIPTION of the part(s) (see the PART LIST on page 22)

PROFORM is a registered trademark of ICON Health & Fitness, Inc.

LIMITED WARRANTY

ICON Health & Fitness, Inc. (ICON), warrants this product to be free from defects in workmanship and material, under normal use and service conditions, for a period of ninety (90) days from the date of purchase. This warranty extends only to the original purchaser. ICON's obligation under this warranty is limited to replacing or repairing, at ICON's option, the product through one of its authorized service centers. All repairs for which warranty claims are made must be pre-authorized by ICON. This warranty does not extend to any product or damage to a product caused by or attributable to freight damage, abuse, misuse, improper or abnormal usage or repairs not provided by an ICON authorized service center, products used for commercial or rental purposes, or products used as store display models. No other warranty beyond that specifically set forth above is authorized by ICON.

ICON is not responsible or liable for indirect, special or consequential damages arising out of or in connection with the use or performance of the product or damages with respect to any economic loss, loss of property, loss of revenues or profits, loss of enjoyment or use, costs of removal, installation or other consequential damages of whatsoever nature. Some states do not allow the exclusion or limitation of incidental or consequential damages. Accordingly, the above limitation may not apply to you.

The warranty extended hereunder is in lieu of any and all other warranties and any implied warranties of merchantability or fitness for a particular purpose is limited in its scope and duration to the terms set forth herein. Some states do not allow limitations on how long an implied warranty lasts. Accordingly, the above limitation may not apply to you.

This warranty gives you specific legal rights. You may also have other rights which vary from state to state.

ICON HEALTH & FITNESS, INC., 1500 S. 1000 W., LOGAN, UT 84321-9813