

HEALTHRIDER[®]

THE TOTAL BODY FITNESS MACHINE

Model No. HRCR91082

Serial No. _____

The serial number can be found in the location shown below. Write the serial number in the space above.

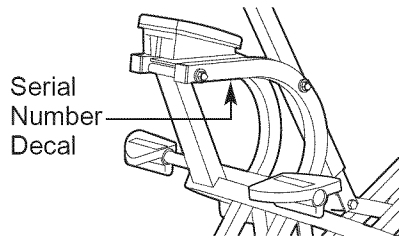

USER'S MANUAL

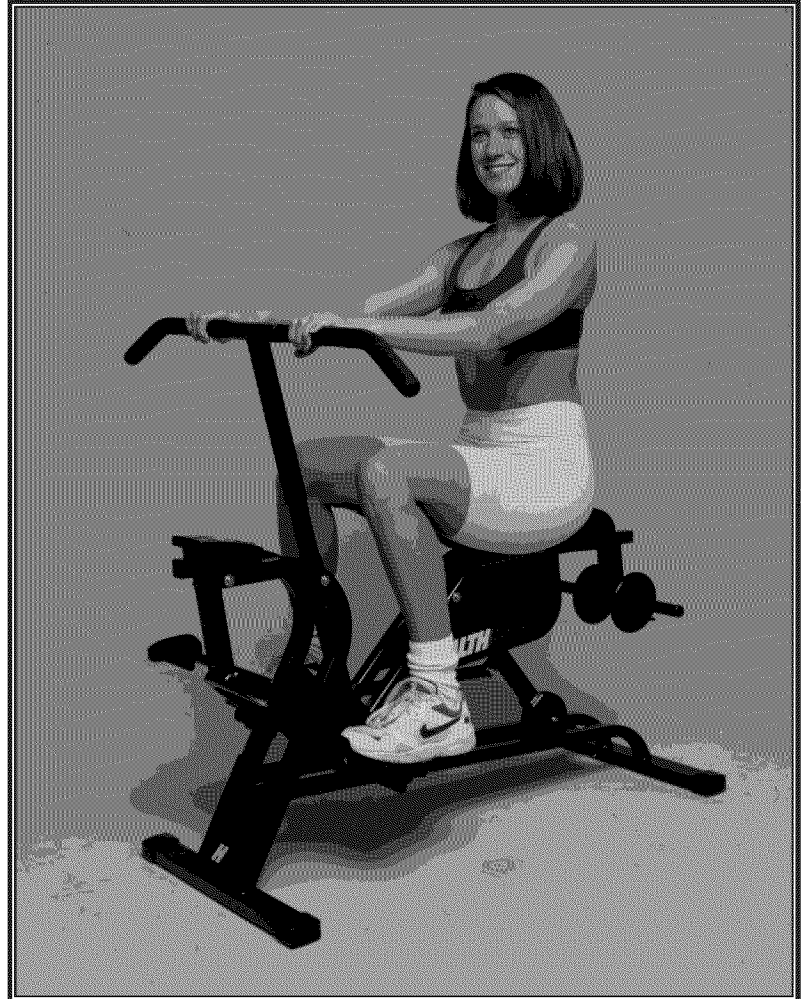

QUESTIONS?

As a manufacturer, we are committed to providing complete customer satisfaction. If you have questions, or if there are missing or damaged parts, we will guarantee complete satisfaction through direct assistance from our factory.

TO AVOID UNNECESSARY DELAYS, PLEASE CALL DIRECT TO OUR TOLL-FREE CUSTOMER HOT LINE. The trained technicians on our customer hot line will provide immediate assistance, free of charge to you.

CUSTOMER HOT LINE:

1-800-999-3756

Mon.-Fri., 6 a.m.-6 p.m. MST

Patent Pending

CAUTION

Read all precautions and instructions in this manual before using this equipment. Save this manual for future reference.



Visit our website at

www.healthrider.com

new products, prizes,
fitness tips, and much more!

TABLE OF CONTENTS

IMPORTANT PRECAUTIONS	2
BEFORE YOU BEGIN	3
ASSEMBLY	4
ADJUSTMENT AND OPERATION	5
MAINTENANCE AND TROUBLE-SHOOTING	8
CONDITIONING GUIDELINES	8
PART LIST	10
EXPLODED DRAWING	11
ORDERING REPLACEMENT PARTS	Back Cover
LIMITED WARRANTY	Back Cover

IMPORTANT PRECAUTIONS

⚠ WARNING: To reduce the risk of serious injury, read the following important precautions before using the HEALTHRIDER®.

1. Read all instructions in this manual before using the HEALTHRIDER®.
2. It is the responsibility of the owner to ensure that all users of the HEALTHRIDER® are adequately informed of all precautions.
3. The HEALTHRIDER® should not be used by persons weighing more than 250 pounds.
4. Keep children under the age of 12 and pets away from the HEALTHRIDER® at all times.
5. Place the HEALTHRIDER® on a level surface during use. Cover the floor beneath the HEALTHRIDER® to protect it.
6. Regularly inspect and tighten all parts of the HEALTHRIDER®.
7. When exercising, do not wear loose clothing that could become caught on the HEALTHRIDER®. Always wear athletic shoes.
8. The total weight of the user and the added weights should not exceed 300 pounds.
9. Use the HEALTHRIDER® only as described in this manual.
10. The HEALTHRIDER® is intended for home use only. Do not use the HEALTHRIDER® in a commercial, rental, or institutional setting.

⚠ WARNING: Before beginning this or any exercise program, consult your physician. This is especially important for persons over the age of 35 or persons with pre-existing health problems. Read all instructions before using. ICON assumes no responsibility for personal injury or property damage sustained by or through the use of this product.

BEFORE YOU BEGIN

Thank you for selecting the new HEALTHRIDER®. The HEALTHRIDER® offers a unique form of low-impact exercise that uses both the upper body and the lower body for greater cardiovascular benefits and increased toning.

For your benefit, please read this manual carefully before using the HEALTHRIDER®. If you have additional questions, please call our toll-free CUSTOMER HOT LINE at 1-800-999-3756, Monday through Friday,

6 a.m. until 6 p.m. Mountain Standard Time (excluding holidays). To help us assist you, please note the product model number and serial number before calling. The model number is HRCR91082. The serial number can be found on a decal attached to the HEALTHRIDER® (see the front cover of this manual).

Before reading further, please review the drawing below and familiarize yourself with the parts that are labeled.

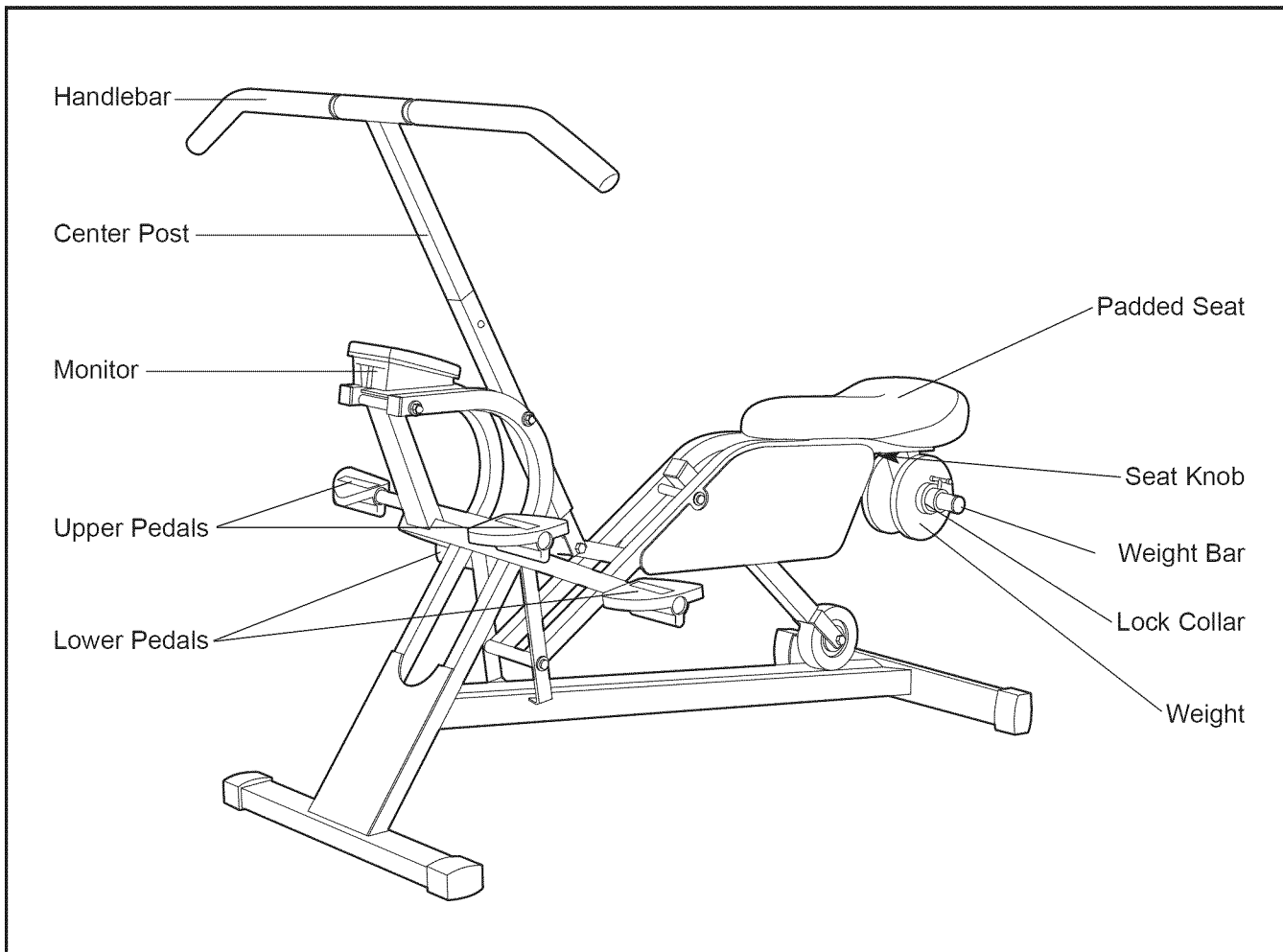

ASSEMBLY

Before beginning assembly, carefully read the following information and instructions:

- Place all parts in a cleared area and remove the packing materials; do not dispose of the packing materials until assembly is completed.

- Read each assembly step carefully before you begin.
- During assembly, make sure that all parts are oriented as shown in the drawings.

1. Depress the Dual End Snap Button (46) in the Handlebar (6) and insert the Handlebar into the Handlebar Swing Arm (5). Make sure that the Dual End Snap Button seats fully into the indicated holes in the Handlebar Swing Arm.

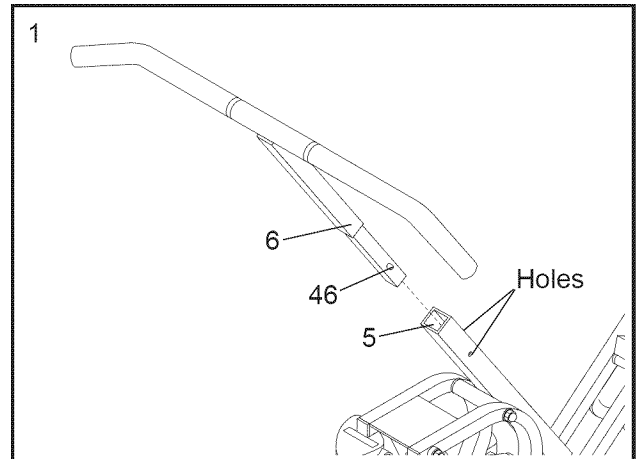

2. Press the Magnet w/Bracket (36) onto the Pedal Frame (4) as shown.

Slide the Monitor (35) fully onto the Main Frame (1) as shown in inset drawing A. Press down on the Monitor as shown in inset drawing B until it snaps into place.

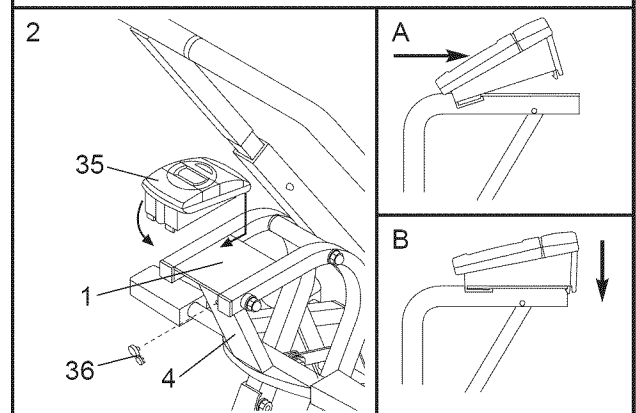

3. Remove the battery cover from the Monitor (35). Insert two new AA batteries into the Monitor. Identify the negative (-) and positive (+) ends of the batteries. The negative ends of the batteries should touch the springs in the battery compartment. .

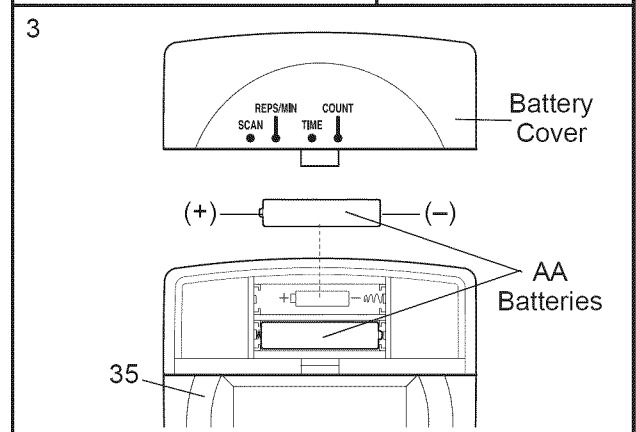

ADJUSTMENT AND OPERATION

DESCRIPTION OF THE MONITOR

The monitor offers four modes to provide you with instant exercise feedback:

- **Reps/Min**—This mode displays your current pace, in repetitions per minute.
- **Time**—This mode displays the length of time you have exercised. **Note:** If you stop exercising for ten seconds or longer, the time mode will pause until you resume.
- **Count**—This mode displays the total number of repetitions you have completed, up to 9,999. The display will then reset to zero and continue counting.
- **Scan**—This mode displays the reps/min, time, and count modes, for approximately 6 seconds each, in a repeating cycle.

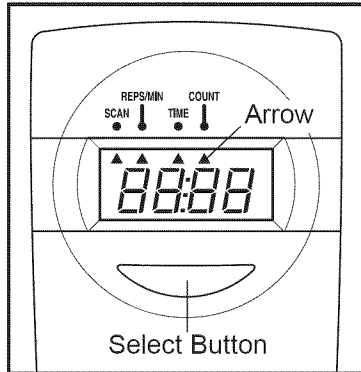

HOW TO OPERATE THE MONITOR

1. To turn on the power, press the select button or simply begin exercising.
2. Select the desired mode:

To select the reps/min, time, or count mode, press the select button repeatedly until an arrow points to the desired mode. Make sure that there is not an arrow pointing to the word "scan."

To select the scan mode, press the select button repeatedly until an arrow points to the word "scan." A second arrow will show which mode is currently displayed.

To reset the time and count modes to zero, hold down the select button for two seconds.

3. **The monitor has an "auto-off" feature.** If the pedals are not moved and the select button is not pressed for four minutes, the power will turn off automatically in order to conserve the batteries.

ADJUSTING THE SEAT

The position of the seat can be adjusted to accommodate different users. To adjust the seat, loosen the knob under the seat, move the seat to the desired position, and retighten the knob. To determine if the seat is properly adjusted, sit on the seat and pull the handlebar as close as possible to your stomach. Your legs should be almost straight, but your knees should not be locked.

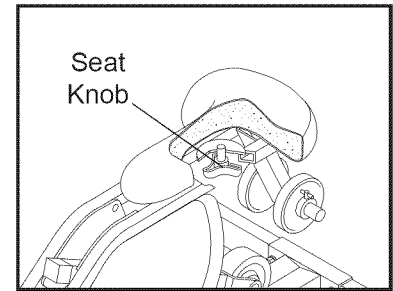

ADDING AND REMOVING WEIGHT

The HEALTHRIDER® features a weight bar that lets you intensify your exercise by adding weights. To add weights, slide the desired amount of weight onto the weight bar. Secure the weights with the lock collars. **Note:**

Place an equal amount of weight on each side of the weight bar. The total combined weight of the user and added weights should not exceed 300 pounds.

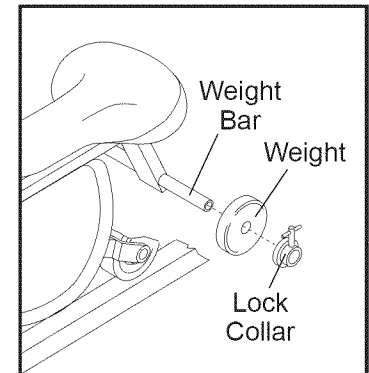

CHANGING THE POSITION OF THE HANDLEBAR

To exercise the muscles of the lower body, the position of the handlebar can be changed.

Remove the Swing Arm Cap (28) from the Wheel Swing Arm (3). Next, press the Snap Buttons (46) and slide the Handlebar Assembly (6) out of the Handlebar Swing Arm (5). Press the Snap Buttons again and insert the Handlebar Assembly into the Wheel Swing Arm (3). **Make sure that the Snap Buttons snap into the holes in the Wheel Swing Arm.** Press the Swing Arm Cap (28) onto the Handlebar Swing Arm (5).

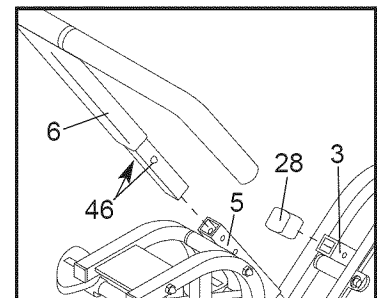

PROPER EXERCISE FORM

On the following pages are exercise guidelines and photographs of the positions that you can use to get the maximum benefit from the HEALTHRIDER®.

- Always start each exercise session in the standard workout position to warm up.
- Pivot or bend from the hip—not from the back. Don't round your back as the bar moves forward.
- Center the balls of your feet on the pedals.
- Always bring the handlebar as close as possible to your torso. Don't extend the bar too far forward for the first few weeks of exercise. Then allow the handlebar to travel farther forward for increased range of motion.
- Change grip positions and toe positions often to add variety and balance to each workout.
- Place your thumbs next to the first finger or wrapped around the handlebar. Change thumb position during each workout session for greater forearm endurance.

1 STANDARD WORKOUT POSITION

We strongly recommend that you begin every exercise session in this position. As a warm-up, it provides a balanced workout, distributing the emphasis between upper and lower body. Vary emphasis by pulling more with the arms or pushing more with the legs. Keep your back vertical and upright at all times. You should also vary your hand grip to target certain muscle groups. For example, a wide overhand grip will target your shoulders; a close overhand grip (shown) will target your triceps; and a close underhand grip will target your biceps.

Muscles affected: All Major Muscle Groups

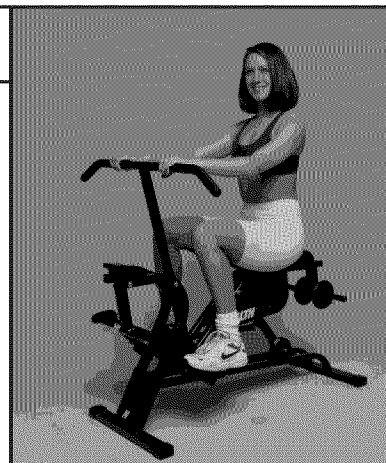

2 WRIST ROLL

As your strength increases, you'll want to challenge yourself by toning your forearms even more. Use the wrist roll with either the close or wide overhand grip. As you pull the handlebar toward your stomach, roll your knuckles forward in a smooth motion.

Muscles affected: Forearm Flexors

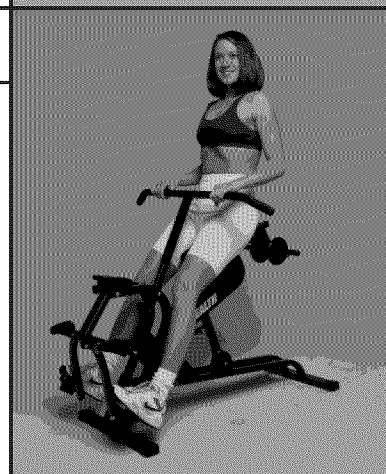

3 CENTER POST GRIP

Grip the center post high with one hand above the other. Perform ten repetitions. Change your hand positions and perform the same number of repetitions. For greater emphasis try one hand at a time.

Muscles affected: Biceps and Chest

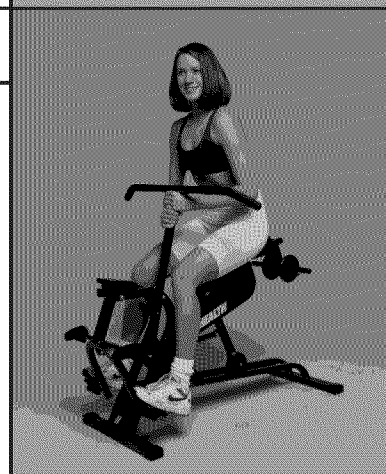

4 TOES STRAIGHT

Place the ball of each foot in the middle of each pedal. Push with your toes pointed forward, then pull your feet back with toes up and heels down. This tones the lower legs. Start with just a few minutes per session and gradually increase with each workout.

Muscles affected: Shins and Calves

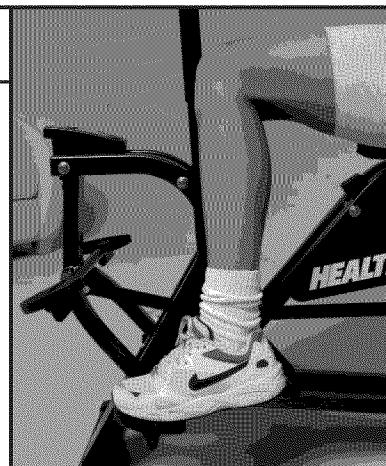

5 TOES TURNED

The direction which your toes are turned will vary the effect of your workout. If your toes are turned slightly in while pointing and flexing, this emphasizes the outer calves. If your toes are turned slightly out while pointing and flexing, this emphasizes the inner calves. You can also turn your toes out and open your knees to tone your inner thighs. Regardless of which toe position you choose, always keep your kneecap in line with your toes.

Muscles affected: Calves and Thighs

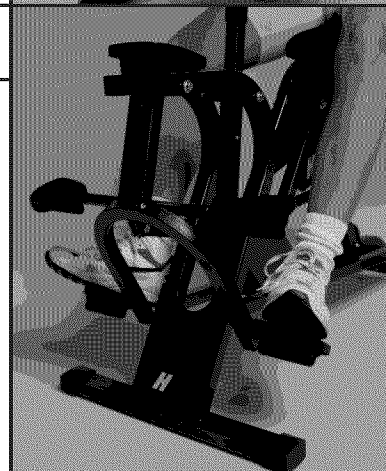

6 UPPER BODY EMPHASIS

Place your feet on the upper pedals and choose any grip.

Muscles affected: Arms, Upper Back, and Chest

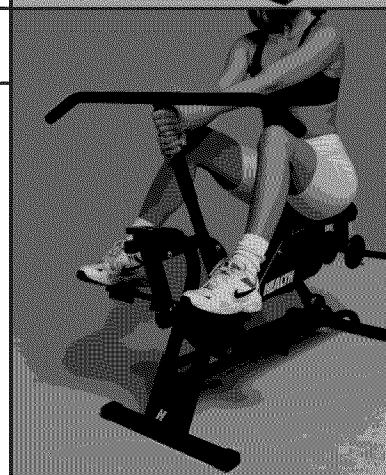

7 LOWER BODY EMPHASIS

Grip the center post low and place your feet on the lower pedals. For more emphasis on the stomach, tighten your abs and pull them in.

Muscles affected: Abdomen, Legs, and Lower Back

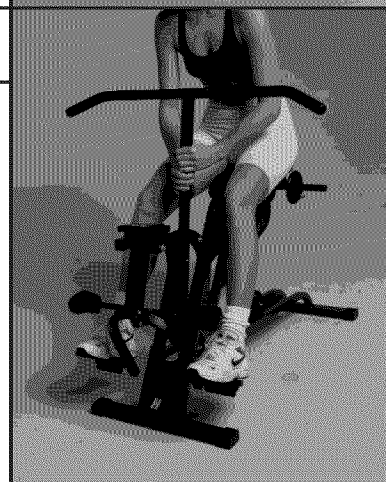

MAINTENANCE AND TROUBLE-SHOOTING

Inspect and tighten all parts of the HEALTHRIDER® regularly. Keep the monitor out of direct sunlight or the display may be damaged. The HEALTHRIDER® can be cleaned with a soft, damp cloth. Do not use solvents. Keep liquid away from the monitor. When storing the HEALTHRIDER®, remove the batteries from the monitor.

HOW TO LUBRICATE THE HEALTHRIDER®

Every three months, a small amount of light multi-purpose oil should be applied to the HEALTHRIDER®. Apply a few drops of oil between the axle caps or acorn nuts and the frame in the locations shown at the right. Make sure to apply oil to both sides of the HEALTHRIDER®.

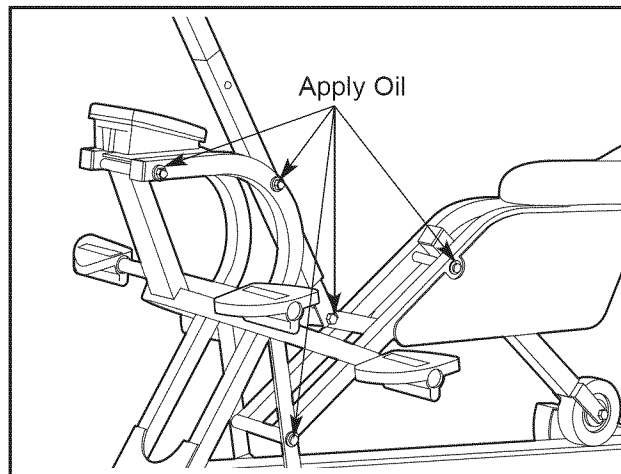

HOW TO REPLACE THE BATTERIES

If the display of the monitor becomes dim, the AA batteries should be replaced. Refer to step 3 on page 41.

CONDITIONING GUIDELINES

The following general guidelines will help you to plan your exercise program. Remember that proper nutrition and adequate rest are essential for successful results.

⚠ WARNING: Before beginning this or any exercise program, consult your physician. This is especially important for persons over the age of 35 or persons with pre-existing health problems.

EXERCISE INTENSITY

Whether your goal is to burn fat or to strengthen your cardiovascular system, the key to achieving the desired results is to exercise with the proper intensity. The proper intensity level can be found by using your heart rate as a guide.

The chart below shows recommended heart rates for fat burning, maximum fat burning, and cardiovascular (aerobic) exercise.

To find the proper heart rate for you, first find your age near the bottom of the chart (ages are rounded off to the nearest ten years). Next, look above your age and find the three numbers in light grey boxes. The three numbers are your "training zone." The lowest number is the recommended heart rate for fat burning; the middle number is the recommended heart rate for maximum fat burning; the highest number is the recommended heart rate for aerobic exercise.

BPM	HEART RATE TRAINING ZONES						
	165						Aerobic
	145	155					Max Fat Burn
	125	138	145				Fat Burn
		120	130	140			
			115	125	130		
				110	118	125	
					105	110	115
						95	103
							90
Age	20	30	40	50	60	70	80

Fat Burning

To burn fat effectively, you must exercise at a relatively low intensity level for a sustained period of time. During the first few minutes of exercise, your body uses easily accessible carbohydrate calories for energy. Only after the first few minutes of exercise does your body begin to use stored fat calories for energy. If your goal is to burn fat, adjust your pace until your heart rate is near the lowest number in your training zone as you exercise.

Maximum Fat Burning

For increased fat burning, adjust your pace until your heart rate is near the middle number in your training zone as you exercise.

Aerobic Exercise

If your goal is to strengthen your cardiovascular system, your exercise must be "aerobic." Aerobic exercise is activity that requires large amounts of oxygen for prolonged periods of time. This increases the demand on the heart to pump blood to the muscles, and on the lungs to oxygenate the blood. For aerobic exercise, adjust your pace until your heart rate is near the highest number in your training zone.

HOW TO MEASURE YOUR HEART RATE

To measure your heart rate, first exercise for at least four minutes. Then, stop exercising and place two fingers on your wrist as shown. Take a six-second heartbeat count,

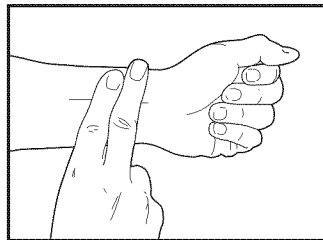

and multiply the result by 10 to find your heart rate. For example, if your six-second heartbeat count is 14, your heart rate is 140 beats per minute. (A six-second count is used because your heart rate will drop rapidly when you stop exercising.)

Adjust your pace until your heart rate is at the desired level.

WORKOUT GUIDELINES

Each workout should include the following three parts:

A warm-up, lasting 5 to 10 minutes. Begin with slow, controlled stretches, and progress to more rhythmic stretches to increase the body temperature, heart rate, and circulation in preparation for exercise.

Training zone exercise, consisting of 20 to 30 minutes of exercising with your heart rate in your training zone. (See the chart on page 8 to find your training zone.)

A cool-down, with 5 to 10 minutes of stretching. Thorough stretching offsets muscle contractions and other problems caused when you stop exercising suddenly. Stretching for increased flexibility is also most effective after exercising. A proper cool-down should leave you relaxed and comfortably tired.

EXERCISE FREQUENCY

To maintain or improve your condition, plan three workouts each week, with at least one day of rest between workouts. After a few months of regular exercise, you may complete up to five workouts each week, if desired. The key to success is make exercise a regular and enjoyable part of your everyday life.

PART LIST—Model No. HRCR91082

R1100A

Key No.	Qty.	Description	Key No.	Qty.	Description
1	1	Main Frame	28	1	Swing Arm Endcap
2	1	Seat Frame	29	8	Medium Bushing
3	1	Wheel Frame Arm	30	4	Short Bushing
4	1	Pedal Frame	31	2	2.5-pound Weight
5	1	Handlebar Swing Arm	32	1	Middle Foam Grip
6	1	Handlebar Assembly w/Foam Grip	33	2	Foam Grip
7	4	M8 Nylon Jam Nut	34	1	Front Cover Panel
8	2	5 lb. Weight	35	1	Monitor
9	2	Lock Collar	36	1	Magnet w/Bracket
10	1	Long Link Arm	37	1	Seat Knob
11	1	Short Link Arm	38	1	Seat Washer
12	1	Seat Bracket	39	2	1.25" Square Endcap
13	2	Pedal/Handle Pin	40	4	1" Square Endcap
14	1	Seat Axle	41	4	Pedal Plug
15	1	Wheel Mount Axle Assembly	42	4	M12 x 5" Bolt
16	1	M8 x 2.375" Wheel Bolt	43	1	Seat Knob Bolt
17	1	M8 x 1.375" Bolt	44	2	M8 x 0.63" Seat Bolt
18	2	M8 x 1" Bolt	45	10	Fastener Base
19	1	Bumper Plate	46	1	Dual End Snap Button
20	1	Seat	47	8	3/8" Hat Cap
21	1	Left Sideshield	48	2	1" Round Endcap
22	1	Right Sideshield	49	6	Plastic Washer
23	2	Left Pedal	50	2	1" x 2" Endcap
24	2	Right Pedal	51	8	Rubber Washer
25	5	Frame Endcap	52	10	Fastener Pin
26	1	Bumper Spacer	#	1	User's Manual
27	1	Rubber Wheel			

Note: "#" indicates a non-illustrated part. Specifications are subject to change without notice. For information about ordering replacement parts, refer to the back page of this manual.

EXPLODED DRAWING—Model No. HRCR91082

R1100A

11

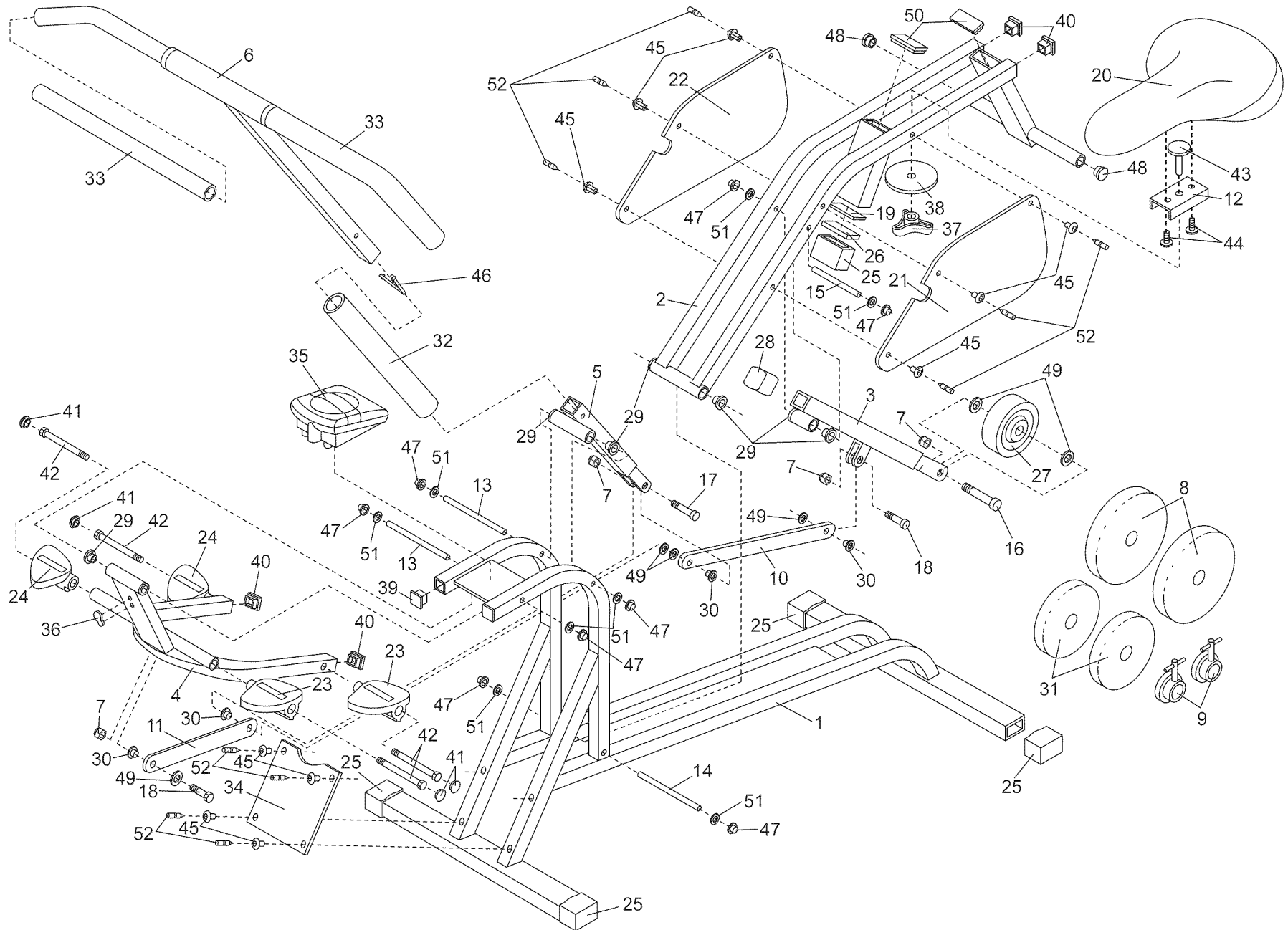

HOW TO ORDER REPLACEMENT PARTS

To order replacement parts, simply call our Customer Service Department toll-free at 1-800-999-3756, Monday through Friday, 6 a.m. until 6 p.m. Mountain Time (excluding holidays). To help us assist you, please be prepared to give the following information when calling:

- The MODEL NUMBER of the product (HRCR91082).
- The NAME of the product (HEALTHRIDER®).
- The PART NUMBER of the PART (see pages 10 and 11 of this manual).
- The DESCRIPTION of the PART (see pages 10 and 11 of this manual).

HEALTHRIDER is a registered trademark of ICON Health & Fitness, Inc.

LIMITED WARRANTY

ICON Health & Fitness, Inc. (ICON) warrants this product to be free from defects in workmanship and material, under normal use and service conditions, for a period of ninety (90) days from the date of purchase. This warranty extends only to the original purchaser. ICON's obligation under this warranty is limited to replacing or repairing, at ICON's option, the product at one of its authorized service centers. All products for which warranty claim is made must be received by ICON at one of its authorized service centers with all freight and other transportation charges prepaid, accompanied by sufficient proof of purchase. All returns must be pre-authorized by ICON. This warranty does not extend to any product or damage to a product caused by or attributable to freight damage, abuse, misuse, improper or abnormal usage or repairs not provided by an ICON authorized service center, to products used for commercial or rental purposes, or to products used as store displays. No other warranty beyond that specifically set forth above is authorized by ICON.

ICON is not responsible or liable for indirect, special or consequential damages arising out of or in connection with the use or performance of the product or damages with respect to any economic loss, loss of property, loss of revenues or profits, loss of enjoyment or use, costs of removal, installation or other consequential damages of whatsoever nature. Some states do not allow the exclusion or limitation of incidental or consequential damages. Accordingly, the above limitation may not apply to you.

The warranty extended hereunder is in lieu of any and all other warranties and any implied warranties of merchantability or fitness for a particular purpose is limited in its scope and duration to the terms set forth herein. Some states do not allow limitations on how long an implied warranty lasts. Accordingly, the above limitation may not apply to you.

This warranty gives you specific legal rights. You may also have other rights which vary from state to state.

ICON HEALTH & FITNESS, INC., 1500 S. 1000 W., LOGAN, UT 84321-9813