

**Lifestyler<sup>®</sup>**

# CARDIOFORCE™

total body workout • adjustable resistance

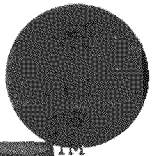

# SEARS

Model No. 831.287421

Serial No. \_\_\_\_\_

Write the serial number in the space above for future reference.

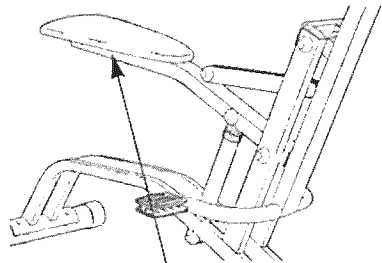

Serial Number Decal

EXERCISE  
EQUIPMENT

**QUESTIONS**

HELPLINE!

1-800-736-6879

Patent Pending

## CAUTION!

Read all precautions and instructions in this manual before using this equipment. Keep this manual for future reference.

## USER'S MANUAL

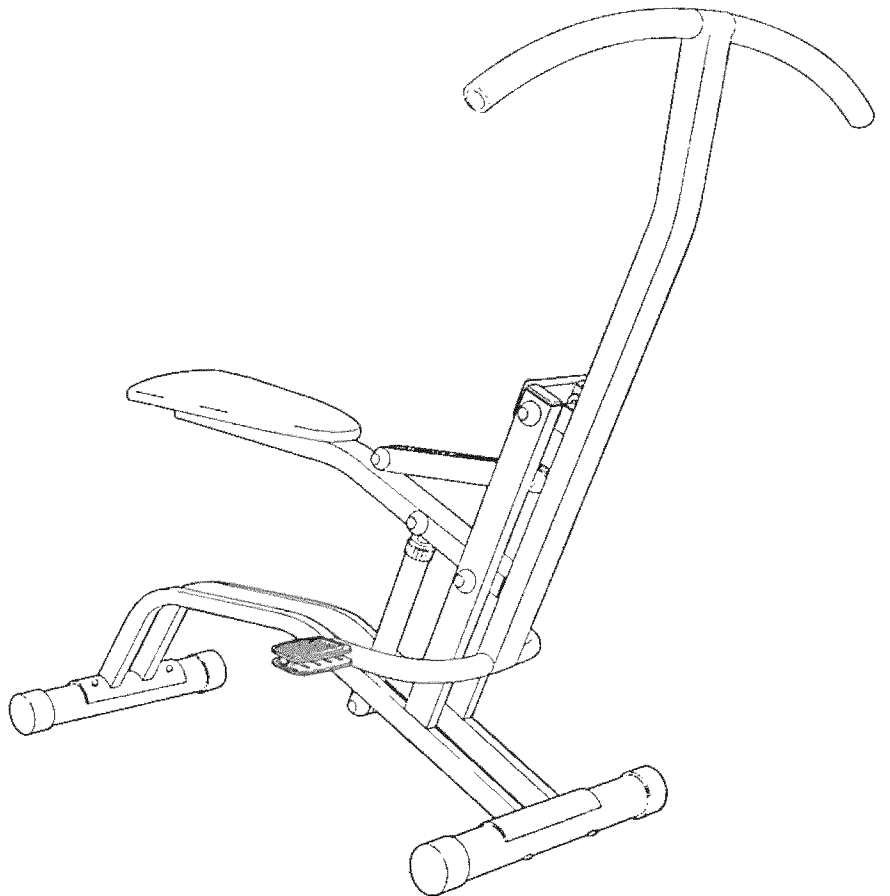

SEARS, ROEBUCK AND CO., HOFFMAN ESTATES, IL 60179

# TABLE OF CONTENTS

IMPORTANT PRECAUTIONS	2
BEFORE YOU BEGIN	3
ASSEMBLY	3
ADJUSTMENT AND OPERATION	6
MAINTENANCE AND TROUBLE-SHOOTING	8
CONDITIONING GUIDELINES	9
PART LIST	10
EXPLODED DRAWING	11
ORDERING REPLACEMENT PARTS	Back Cover
WARRANTY	Back Cover

## IMPORTANT PRECAUTIONS

**WARNING:** To reduce the risk of serious injury, read the following important precautions before using the **CARDIO FORCE**.

1. Use the **CARDIO FORCE** only on a level surface.
2. Keep small children and pets away from the **CARDIO FORCE** at all times.
3. Wear appropriate clothing when exercising; do not wear loose clothing that could become caught in the **CARDIO FORCE**. Always wear athletic shoes for foot protection.
4. The resistance cylinder becomes very hot during use. Allow the resistance cylinder to cool before touching it. Note: Due to the nature of resistance cylinders, it is recommended that the floor underneath the **CARDIO FORCE** be covered in case of slight oil leakage.
5. Use the **CARDIO FORCE** only as described in this manual.

**WARNING:** Before beginning this or any exercise program, consult your physician. This is especially important for persons over the age of 35 or persons with pre-existing health problems. Read all instructions before using. SEARS assumes no responsibility for personal injury or property damage sustained by or through the use of this product.

# BEFORE YOU BEGIN

Thank you for selecting the innovative SEARS LIFESTYLER<sup>®</sup> CARDIO FORCE. The CARDIO FORCE offers a unique form of low-impact exercise that uses both the upper body and the lower body for increased cardiovascular benefits and greater toning results.



For your benefit, read this manual carefully before you use the CARDIO FORCE. If you have additional

questions, please call our toll-free HELPLINE at 1-800-736-6879, Monday through Saturday, 7 a.m. until 7 p.m. Central Time (excluding holidays). To help us assist you, please note the product model number and serial number when calling. The model number is 831.287421. The serial number can be found on a decal attached to the CARDIO FORCE (see the front cover of this manual).

## ASSEMBLY

Place all parts of the CARDIO FORCE in a cleared area and remove the packing materials. Do not dispose of the packing materials until assembly is completed. Read each step carefully before beginning.

THE FOLLOWING TOOLS (NOT INCLUDED) ARE REQUIRED FOR ASSEMBLY:

- one phillips screwdriver 
- one adjustable wrench 
- one rubber mallet 

- the included pedal tool (see the drawing below).

### PART CHART

Use the drawings below to identify the small parts used in assembly. The number in parenthesis below each drawing refers to the key number of the part. The second number indicates the quantity needed for assembly. Note: Some small parts may have been pre-attached for shipping purposes. If a part is not found in the parts bag, check to see if it has been pre-attached.

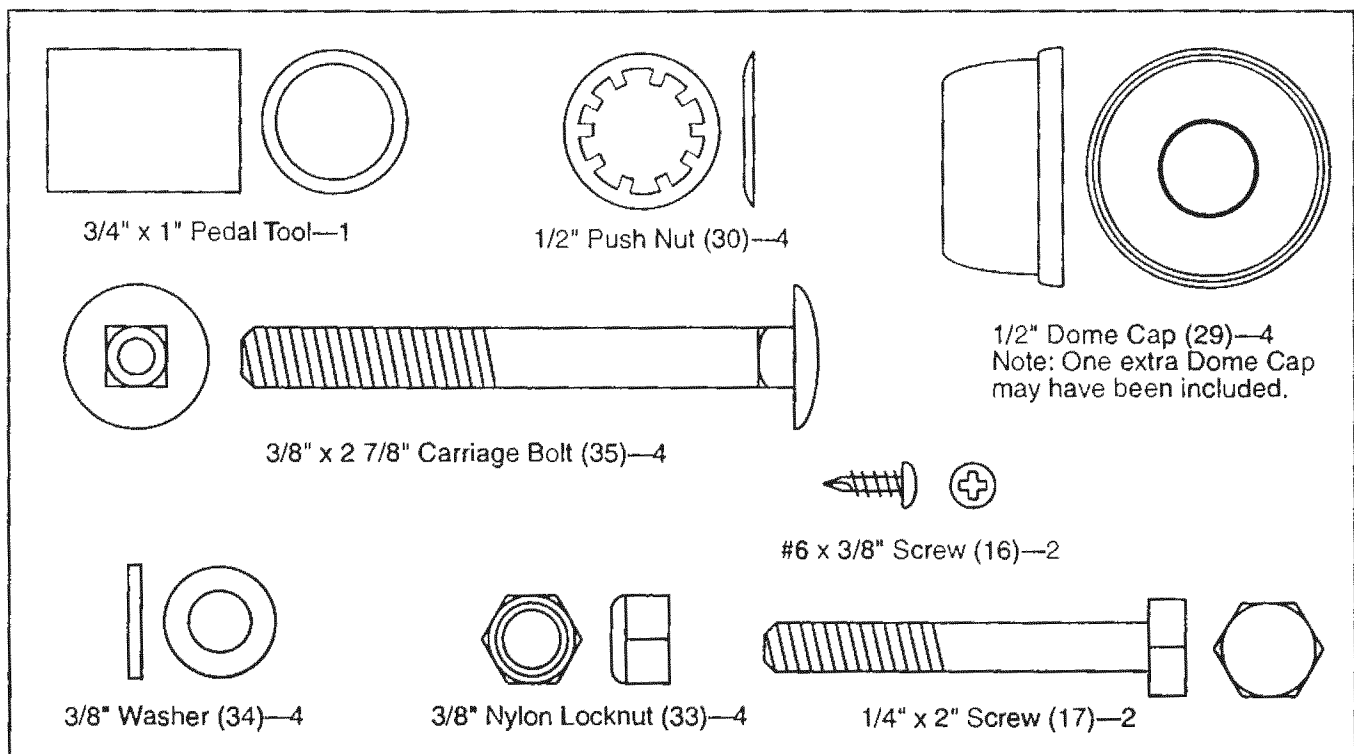

1. Find the Front Stabilizer (36), which has a decal on it. Make sure that there is a Large Round Endcap (8) on each end of the Front Stabilizer.

Attach the Front Stabilizer (36) to the Frame (6) with two 3/8" x 2 7/8" Carriage Bolts (35), 3/8" Washers (34), and 3/8" Nylon Locknuts (33). Make sure that the square holes in the Front Stabilizer are turned toward the floor.

Attach the Rear Stabilizer (32) to the Frame (6) in the same manner.

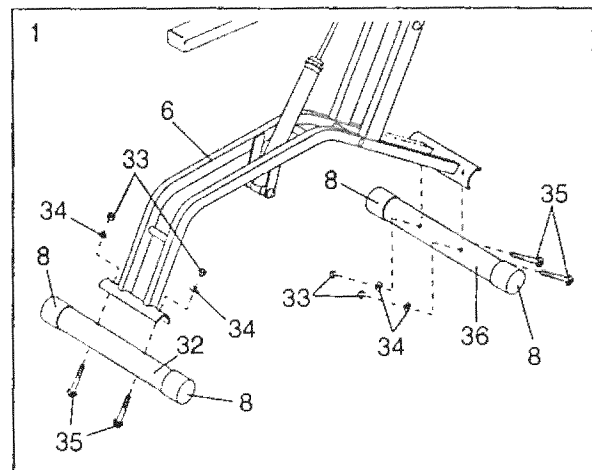

2. Plug the Sensor Wire (15) into the back of the Monitor (1). Attach the Monitor to the bracket on the Frame (6) with the two #6 x 3/8" Screws (16). Make sure that the Sensor Wire is not pinched between the Monitor and the Frame.

**IMPORTANT:** Before assembling the 1/2" Dome Caps (29) in steps 3 and 4, be sure that all parts are oriented as shown. The Dome Caps can be used only once; if they must be removed, it will be necessary to order new Dome Caps.

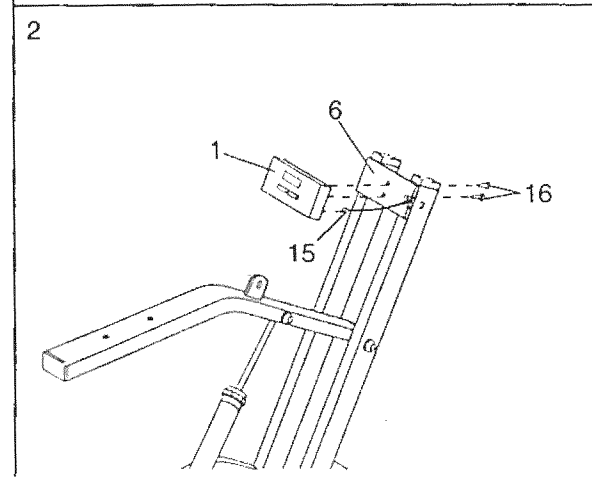

3. Make sure that there are two 1/2" Pivot Bushings (20) in the indicated bracket on the Pedal Frame (7). Hold the pedal frame so the bracket is between the holes near the upper end of the Frame (6). Make sure that the ends of the Link Arms (4) are inserted through the Frame. Apply grease to the 5 1/2" Pivot Axle (21). Insert the Pivot Axle through the Pedal Frame and the Frame. Tap a 1/2" Dome Cap (29) onto each end of the Pivot Axle.

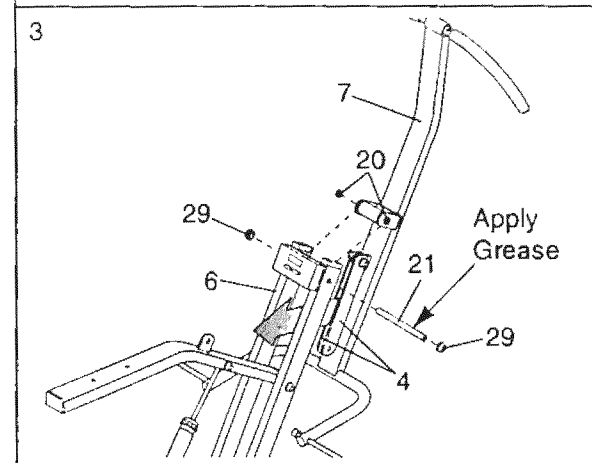

4. Make sure that there is a 1/2" Link Arm Bushing (19) in the end of each Link Arm (4) (see the right inset drawing). Align the ends of the Link Arms with the indicated bracket on the Seat Tube (5). Insert the 1 3/4" Axle (22) through the Link Arms and the bracket. Using the included pedal tool, tap a 1/2" Push Nut (30) onto each end of the Axle. Make sure that the Push Nuts are turned so the teeth bend away from the Link Arms (see the left inset drawing). Tap a 1/2" Dome Cap (29) onto each end of the Axle.

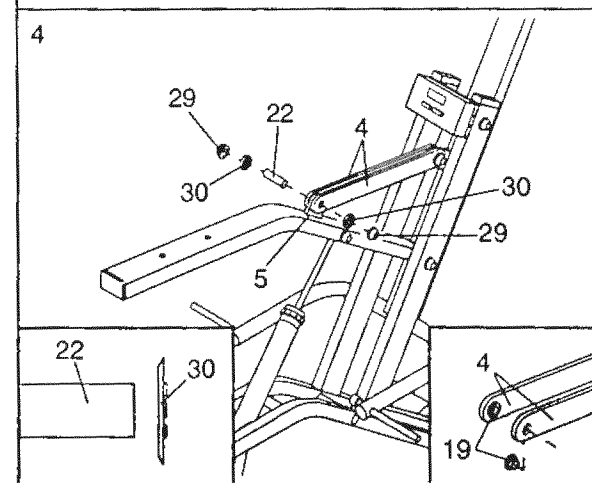

- Attach the Seat (3) to the Seat Tube (5) with the two 1/4" x 2" Screws (17). Be sure that the Seat is oriented as shown.

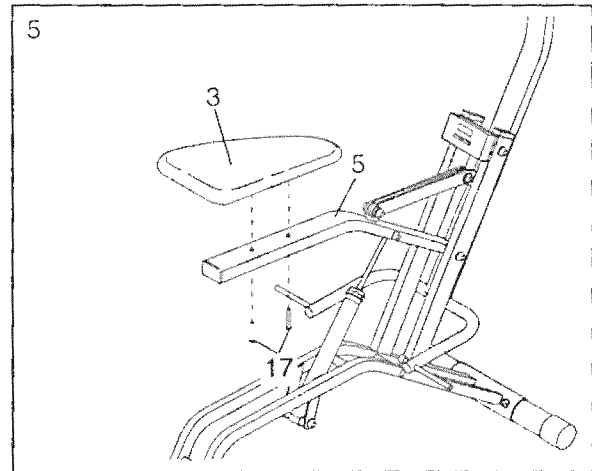

- Apply a small amount of grease to the two indicated shafts of the Pedal Frame (7). Slide a Pedal (12) onto the right shaft. Make sure that the Pedal is turned so the plastic tube is facing the Pedal Frame, as shown. Using the included pedal tool, tap a 1/2" Push Nut (30) onto the end of the shaft. **Be sure that the Push Nut is turned as shown in the inset drawing.**

Attach the other Pedal (12) (not shown) to the left shaft of the Pedal Frame (7) in the same manner.

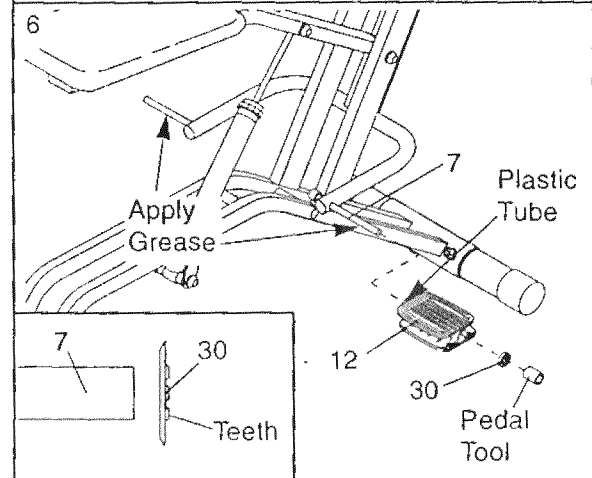

- Before using the CARDIO FORCE, check the Magnet (18) and the Reed Switch (15). Pivot the Pedal Frame (7) until the Magnet is aligned with the Reed Switch (see the inset drawing). Loosen the #8 x 3/4" Screw (27). Adjust the position of the Reed Switch so that there is a 1/8" gap between the Magnet and the Reed Switch. Retighten the Screw.

Make sure that all parts of the CARDIO FORCE are properly tightened.

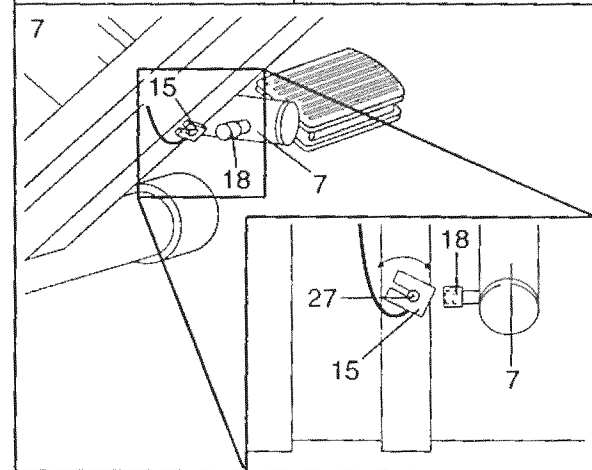

# ADJUSTMENT AND OPERATION

Place the **CARDIO FORCE** on a level surface. Keep the electronic monitor out of direct sunlight, or the display may be damaged. It is recommended that the floor underneath the **CARDIO FORCE** be covered in case of slight oil leakage.

## DESCRIPTION OF THE MONITOR MODES

The **CARDIO FORCE** features one of the two monitors shown below. Both monitors have exactly the same modes. The modes are described below:

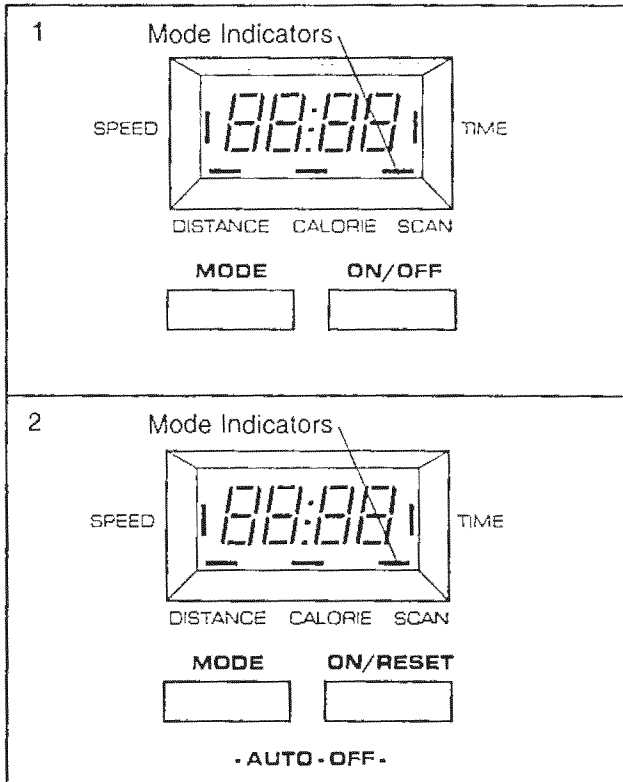

**Speed**—Displays your speed, in repetitions per minute.

**Time**—Displays the length of time you have exercised. Note: If you stop exercising for ten seconds or longer, the time mode will pause until you resume.

**Distance**—Displays the total number of repetitions you have completed, up to 999 or 9,999. The display will then reset to zero and continue counting.

**Calories**—Displays the approximate number of Calories you have burned. Note: If the resistance is on the highest or lowest setting, the actual number of Calories you have burned will be slightly higher or lower than the number displayed.

**Scan**—Displays the speed, time, distance and calories modes, for about 5 seconds each, in a repeating cycle.

## HOW TO OPERATE THE MONITOR

Note: If there is a thin sheet of clear film on the front of the monitor, remove it before operating the monitor.

1. To turn on the power, press the on/off button or the on/reset button, or simply begin exercising. The entire display will appear for two seconds. The monitor will then be ready for operation.

2. Select one of the five modes:

**Scan mode**—When the power is turned on, the scan mode will be selected automatically. One mode indicator will show that the scan mode has been selected, and a second mode indicator will show which mode is currently displayed. The scan mode can also be selected by pressing the mode button.

**Speed, time, distance or calories mode**—These modes can be selected by repeatedly pressing the mode button. The mode indicators will show which mode has been selected. (Make sure that the scan mode is not selected.) The modes will be selected in the following order: speed, time, distance, calories.

3. To reset the display, press the on/off button twice if you have monitor 1, or the on/reset button if you have monitor 2.

4. To turn off the power, press the on/off button if you have monitor 1, or simply wait for four minutes if you have monitor 2. **Both monitors have auto-off features. If the pedals are not moved and the monitor buttons are not pressed for about four minutes, the power will turn off automatically.**

## EXERCISING ON THE **CARDIO FORCE**

Sit on the seat, place your feet on the pedals and hold the handlebar. To add variety to your exercise, you can place your hands close together or far apart, or hold the handlebar with an overhand or underhand grip.

To begin exercising, pull the handlebar towards your waist while pushing the pedals away with your legs. Return to the starting position. This completes one repetition. Repeat, moving with a smooth, continuous motion. Move through the full range of motion, maintain a steady pace, and keep your back straight.

## ABDOMINAL EXERCISE

To exercise your abdominal muscles, keep your arms straight and bend back at the waist as you exercise. Remember to keep your back straight.

## RESISTANCE ADJUSTMENT

To vary the intensity of your exercise, the resistance of the **CARDIO FORCE** can be changed. There are 9 resistance levels: level 1 is the easiest, and level 9 is the most difficult. To change the resistance, turn the resistance adjustment collar on the Resistance Cylinder (9). The arrow on the Resistance Cylinder will show which resistance level you have selected.

**CAUTION:** The Resistance Cylinder becomes very hot during use. Allow the Resistance Cylinder to cool before touching it.

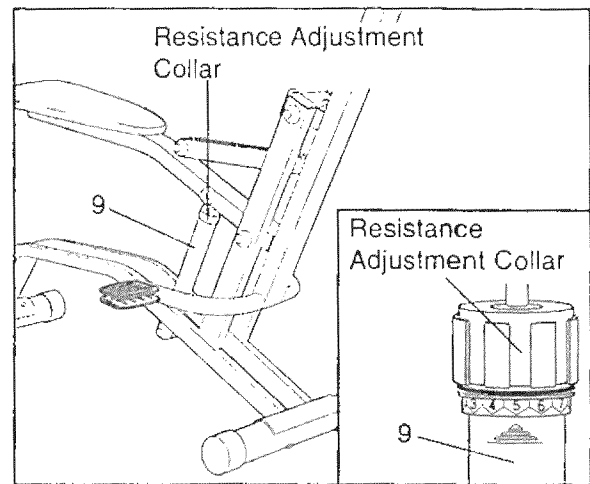

# MAINTENANCE AND TROUBLE-SHOOTING

## MONITOR CARE

Tighten all parts of the **CARDIO FORCE** regularly. The **CARDIO FORCE** can be cleaned with a soft, damp cloth. Do not allow liquid to come in contact with the monitor. Keep the monitor out of direct sunlight or the LCD display may be damaged.

## REPLACING THE BATTERIES

If the display of the Monitor (1) becomes dim, the two **L1154 watch batteries** should be replaced. See drawing A. Remove the upper #6 x 3/8" Screw (16) from the back of the Monitor (1). Pivot the Pedal Frame (7) as shown in drawing B. Remove the lower #6 x 3/8" Screw (16) from the back of the Monitor. Remove the Sensor Wire (15) from the back of the Monitor. See the inset drawing. Remove the four screws from the back cover of the Monitor and remove the back cover. Push the two old batteries out of the clips, and insert two new batteries.

Reattach the back cover of the Monitor (1). Plug the Sensor Wire (15) into the back of the Monitor. Insert any excess wire into the Frame (6). Reattach the Monitor to the Frame with the two #6 x 3/8" Screws (16).

## ADJUSTING THE MAGNET AND REED SWITCH

If the monitor does not function properly, the Magnet (18) and Reed Switch (15) should be checked. Pivot the Pedal Frame (7) until the Magnet is aligned with the Reed Switch. Loosen the #8 x 3/4" Screw (27) and adjust the position of the Reed Switch so that there is a **1/8" gap** between the Magnet and the Reed Switch. Retighten the Screw.

## LUBRICATING THE **CARDIO FORCE**

The **CARDIO FORCE** should be oiled every six months in the locations shown at the right. Apply a few drops of light multi-purpose oil between each of the indicated dome caps and the frame. Be sure to apply oil to each side of the **CARDIO FORCE**.

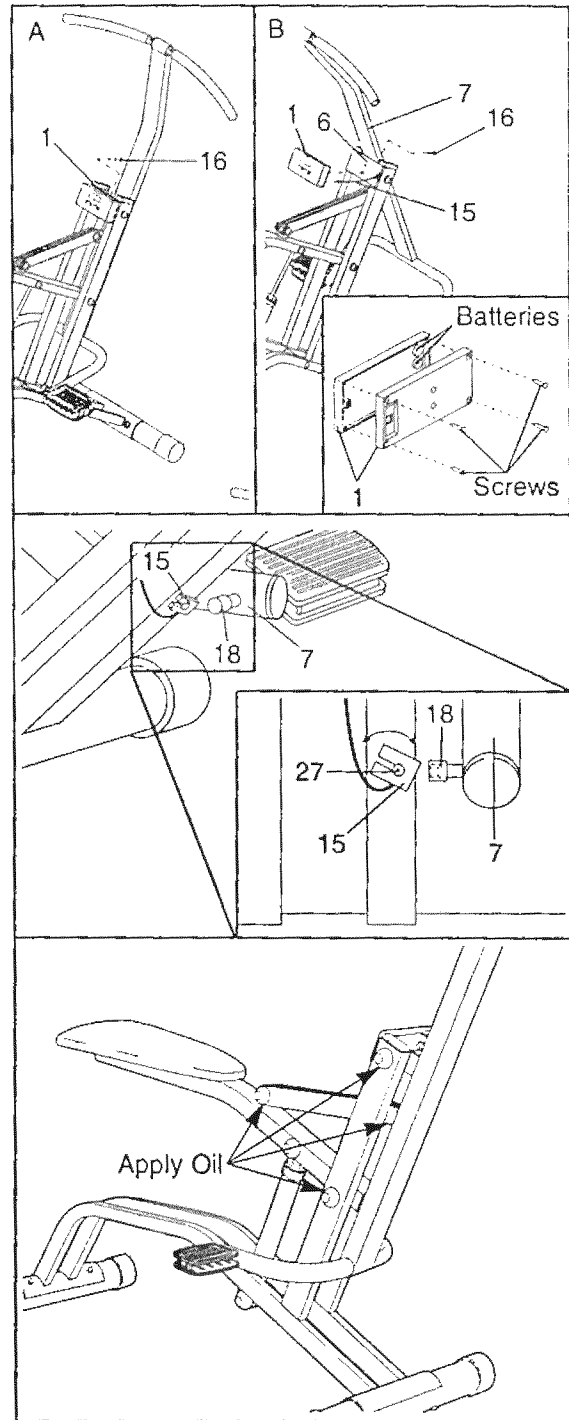



# CONDITIONING GUIDELINES

The following guidelines will help you to plan your exercise program. Remember that proper nutrition and adequate rest are essential for successful results.

**WARNING:** Before beginning this or any exercise program, consult your physician. This is especially important for persons over the age of 35 or persons with pre-existing health problems.

## EXERCISE INTENSITY

To maximize the benefits of exercising, it is important to exercise with the proper intensity. The proper intensity level can be found by using your heart rate as a guide. For effective aerobic exercise, your heart rate should be maintained at a level between 70% and 85% of your maximum heart rate as you exercise. This is known as your training zone. You can find your training zone in the table below. Training zones are listed for both unconditioned and conditioned persons according to age.

AGE	UNCONDITIONED TRAINING ZONE (BEATS/MIN)	CONDITIONED TRAINING ZONE (BEATS/MIN)
20	138-167	133-162
25	136-166	132-160
30	135-164	130-158
35	134-162	129-156
40	132-161	127-155
45	131-159	125-153
50	129-156	124-150
55	127-155	122-149
60	126-153	121-147
65	125-151	119-145
70	123-150	118-144
75	122-147	117-142
80	120-146	115-140
85	118-144	114-139

During the first few months of your exercise program, keep your heart rate near the low end of your training zone as you exercise. After a few months, your heart rate can be increased gradually until it is near the middle of your training zone as you exercise.

To measure your heart rate, stop exercising and place two fingers on your wrist. Take a six-second heartbeat count, and multiply the

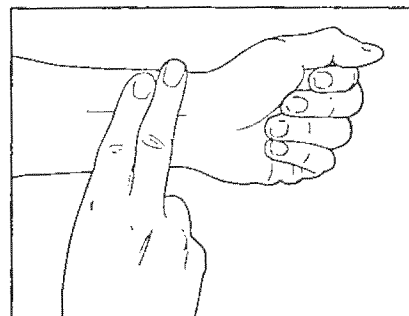

result by 10 to find your heart rate. For example, if your six-second heartbeat count is 14, your heart rate is 140 beats per minute. (A six-second count is used because your heart rate will drop rapidly when you stop exercising.) Adjust the intensity of your exercise until your heart rate is at the proper level.

## WORKOUT GUIDELINES

A well-rounded workout should include the following three phases:

**A warm-up phase**, lasting 5 to 10 minutes. Begin with slow, controlled stretches, and progress to more rhythmic stretches to increase the body temperature, heart rate and circulation in preparation for strenuous exercise. Stretching also guards against muscle, tendon and ligament sprains.

**A cardiovascular phase**, including 20–30 minutes of exercising with your heart rate in your training zone.

**A cool-down phase**, consisting of 5–10 minutes of stretching. Thorough stretching offsets muscle contractions and other problems caused when you stop exercising suddenly. Stretching for increased flexibility is often most effective during this phase. This phase should leave you relaxed and comfortably tired.

After a few months of regular exercise, you may complete up to five workouts each week, if desired. Remember, the key to success is make exercise a regular and enjoyable part of your everyday life.

# PART LIST—Model No. 831.287421

R1095A

Key No.	Part No.	Qty.	Description	Key No.	Part No.	Qty.	Description
1	124883	1	Monitor	21	127159	2	5 1/2" Pivot Axle
2	126512	1	Handlebar	22	125397	2	1 3/4" Axle
3	126013	1	Seat	23	106876	2	1/2" Cylinder Bushing Set
4	126510	2	Link Arm	24	126519	2	3/4" Spacer
5	127158	1	Seat Tube	25	123131	2	1" Bushing
6	NSP	1	Frame	26	125436	1	1/2" x 3" Axle
7	127157	1	Pedal Frame	27	013300	1	#8 x 3/4" Screw
8	109416	4	Large Round Endcap	28	126518	2	Handlebar Foam Grip
9	117555	1	Resistance Cylinder	29	103903	12	1/2" Dome Cap
10	117545	2	1 1/4" Endcap	30	012155	6	1/2" Push Nut
11	117544	2	1 1/2" x 2" Endcap	31	127142	1	1/2" x 3 3/4" Axle
12	126406	2	Pedal	32	127208	1	Rear Stabilizer
13	126025	2	1" x 2" Endcap	33	012149	4	3/8" Nylon Locknut
14	102308	2	#8 x 1/2" Screw	34	014086	4	3/8" Washer
15	124434	1	Reed Switch/Sensor Wire	35	120622	4	3/8" x 2 7/8" Bolt
16	100244	2	#6 x 3/8" Screw	36	127578	1	Front Stabilizer
17	013498	2	1/4" x 2" Screw	37	120733	2	Handlebar Endcap
18	113349	1	Magnet/Retainer	38	126517	2	Plastic Spacer
19	103677	4	1/2" Link Arm Bushing	#	127451	1	User's Manual
20	124546	4	1/2" Pivot Bushing	#	125453	1	3/4" x 1" Pedal Tool

Note: "#" indicates a non-illustrated part. Specifications are subject to change without notice. See the back cover of this manual for information about ordering replacement parts.

# EXPLODED DRAWING—Model No. 831.287421

R1095A

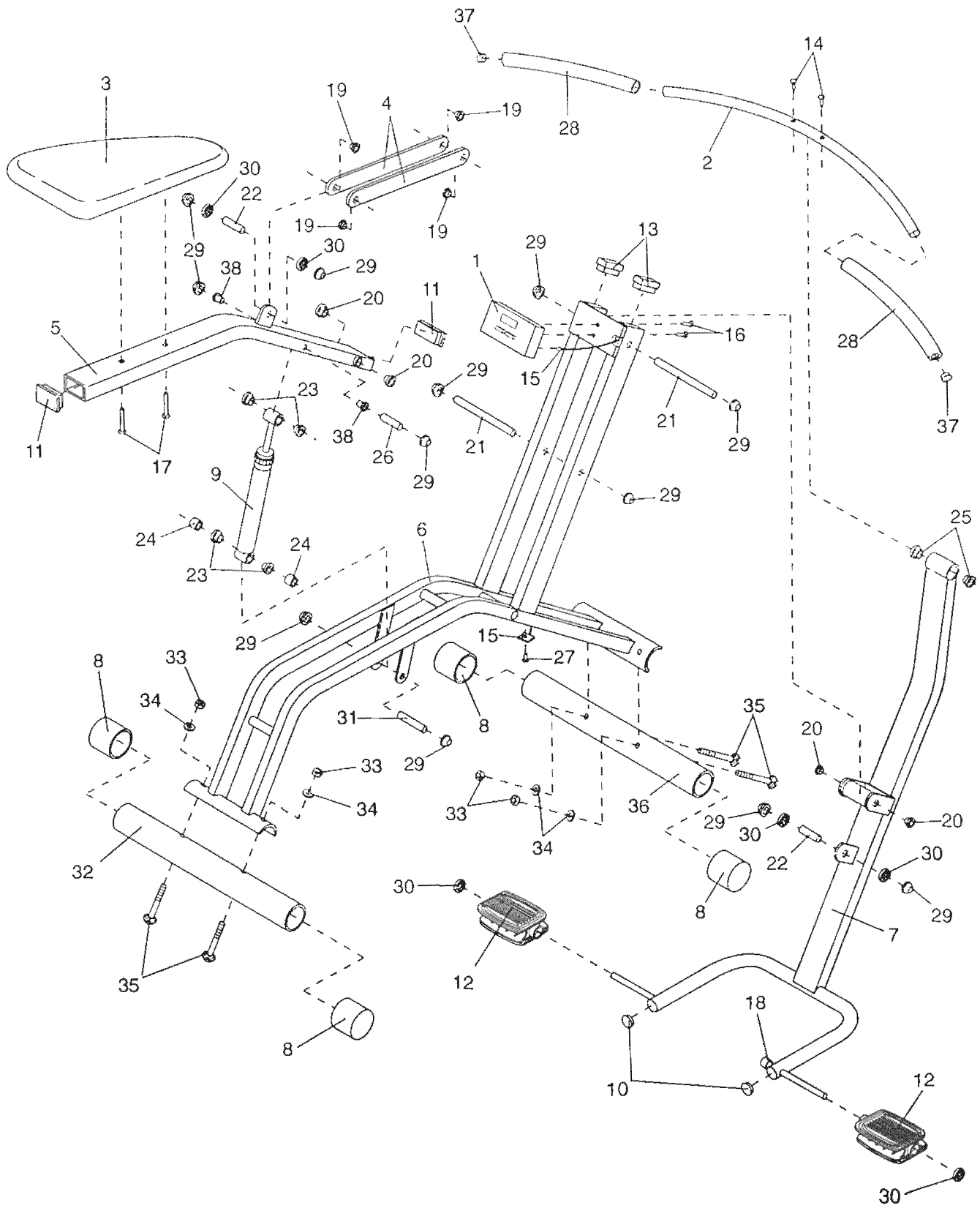



Model No. 831.287421

## QUESTIONS?

If you find that:

- you need help assembling or operating the **CARDIO FORCE**
- a part is missing
- or you need to schedule repair service

call our toll-free **HELPLINE**

**1-800-736-6879**

Monday-Saturday, 7 am-7 pm  
Central Time (excluding holidays)

## REPLACEMENT PARTS

If parts become worn and need to be replaced, call the following toll-free number

**1-800-FON-PART**  
**(1-800-366-7278)**

The model number and serial number of your SEARS LIFESTYLER® **CARDIO FORCE** are listed on a decal attached to the frame. See the front cover of this manual to find the location of the decal.

All replacement parts are available for immediate purchase or special order when you visit your nearest SEARS Service Center. To request service or to order parts by telephone, call the toll-free numbers listed at the left.

When requesting help or service, or ordering parts, please be prepared to provide the following information:

- The **NAME OF THE PRODUCT** (SEARS LIFESTYLER® **CARDIO FORCE**)
- The **MODEL NUMBER OF THE PRODUCT** (831.287421)
- The **PART NUMBER OF THE PART** (see page 10 of this manual)
- The **DESCRIPTION OF THE PART** (see page 10 of this manual)

## FULL 90 DAY WARRANTY

For 90 days from the date of purchase, if failure occurs due to defect in material or workmanship in this SEARS **CARDIO FIT EXERCISER**, contact the nearest SEARS Service Center throughout the United States and SEARS will repair or replace the **CARDIO FIT EXERCISER**, free of charge.

This warranty does not apply when the **CARDIO FIT EXERCISER** is used commercially or for rental purposes.

This warranty gives you specific legal rights, and you may also have other rights which vary from state to state.

**SEARS, ROEBUCK AND CO., DEPT. 817WA, HOFFMAN ESTATES, IL 60179**