

Use & Care Guide  
Manual de Uso y Cuidado  
Guide d'utilisation et d'entretien  
English / Español / Français

Models/Modelos/Modèles: 253.28459, 28452, 28052, 28432, 28732, 28782,  
28042, 28722, 28262, 16342, 16542, 16922, 16949  
970.18412, 18002, 18702, 15502, 14722, 15532,  
14372, 18202

# Kenmore®

## Freezer Congelador Congélateur

P/N 297436900 (1208)  
Sears Brands Management Corporation  
Hoffman Estates, IL 60179 U.S.A.  
[www.kenmore.com](http://www.kenmore.com)  
[www.sears.com](http://www.sears.com)

Sears Canada Inc.  
Toronto, Ontario, Canada M5B 2C3  
[www.sears.ca](http://www.sears.ca)



# Record Model/Serial Numbers

## Please read and save these instructions

This Use & Care Guide provides specific operating instructions for your model. Use your unit only as instructed in this Use & Care Guide. These instructions are not meant to cover every possible condition and situation that may occur. Common sense and caution must be practiced when installing, operating and maintaining any appliance.

Please record your model and serial numbers below for future reference. This information is found on the serial plate located either on the upper left wall inside the freezer (upright models) or the left exterior wall (chest models).

Model Number: 253.  
or 970.  
Serial Number: \_\_\_\_\_  
Purchase Date: \_\_\_\_\_

**IMPORTANT**  
Use only soap and water to clean serial plate.

# Table of Contents

Record Model/Serial Numbers.....2  
Important Safety Instructions.....2  
Warranty Information.....4  
Master Protection Agreements.....5  
First Steps.....6  
Energy Saving Tips.....7  
Setting the Temperature Control.....8  
Optional Features.....9  
Care & Cleaning.....11  
Power Failure / Freezer Failure.....13  
Before You Call.....14  
SearsService.....16

# Important Safety Instructions

## Safety Precautions

Do not attempt to install or operate your unit until you have read the safety precautions in this manual. Safety items throughout this manual are labeled with a Danger, Warning, or Caution based on the risk type.

## Definitions

 This is the safety alert symbol. It is used to alert you to potential personal injury hazards. Obey all safety messages that follow this symbol to avoid possible injury or death.

 **DANGER**  
DANGER indicates an imminently hazardous situation which, if not avoided, will result in death or serious injury.

 **WARNING**  
WARNING indicates a potentially hazardous situation which, if not avoided, could result in death or serious injury.

 **CAUTION**  
CAUTION indicates a potentially hazardous situation which, if not avoided, may result in minor or moderate injury.

**IMPORTANT**  
Indicates installation, operation, or maintenance information which is important but not hazard-related.

# Important Safety Instructions



## WARNING

Please read all safety instructions before using your new appliance.

### For Your Safety

- Do not store or use gasoline, or other flammable liquids in the vicinity of this or any other appliance. Read product labels for warnings regarding flammability and other hazards.
- Do not operate the unit in the presence of explosive fumes.
- Remove and discard any spacers used to secure the shelves during shipping. Small objects are a choke hazard to children.
- Remove all staples from the carton. Staples can cause severe cuts, and also destroy finishes if they come in contact with other appliances or furniture.

### Child Safety

Destroy or recycle the carton, plastic bags, and any exterior wrapping material immediately after the unit is unpacked. Children should NEVER use these items to play. Cartons covered with rugs, bedspreads, plastic sheets or stretch wrap may become airtight chambers, and can quickly cause suffocation.

### Proper disposal of your appliance

#### Risk of child entrapment

Child entrapment and suffocation are not problems of the past. Junked or abandoned appliances are still dangerous – even if they will sit for “just a few days.” If you are getting rid of your appliance, please follow the instructions below to help prevent accidents.

#### Before you throw away your old unit:

- Remove doors.
- Leave shelves in place so children may not easily climb inside.

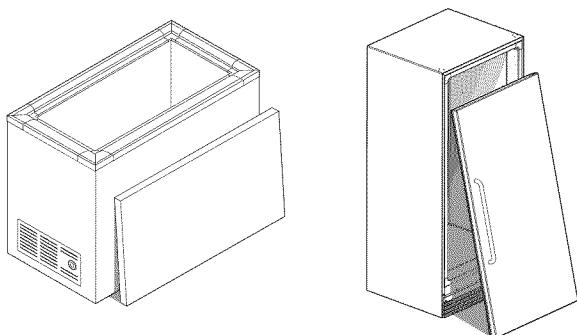

## IMPORTANT

Your old unit may have a cooling system that used CFCs or HCFCs (chlorofluorocarbons or hydrochlorofluorocarbons). CFCs and HCFCs are believed to harm stratospheric ozone if released to the atmosphere. Other refrigerants may cause harm to the environment if released to the atmosphere. If you are throwing away your old unit, make sure the refrigerant is removed for proper disposal by a qualified technician. If you intentionally release refrigerant, you may be subject to fines and imprisonment under the provisions of environmental legislation.



## WARNING

These guidelines must be followed to ensure that safety mechanisms in this unit will operate properly.

### ELECTRICAL INFORMATION

- Refer to the serial plate for correct electrical rating. The power cord of the appliance is equipped with a three-prong grounding plug for your protection against electrical shock hazards. It must be plugged directly into a properly grounded three-prong receptacle. The receptacle must be installed in accordance with local codes and ordinances. Consult a qualified electrician. Do not use an extension cord or adapter plug.
- Immediately repair or replace any power cord that becomes frayed or damaged.
- Never unplug the unit by pulling on the power cord. Always grip the plug firmly, and pull straight out from the receptacle to prevent damaging the power cord.
- Unplug the unit before cleaning and before replacing a light bulb to avoid electrical shock.
- Performance may be affected if the voltage varies by 10% or more. Operating the unit with insufficient power can damage the compressor. Such damage is not covered under your warranty.
- Do not plug the unit into an outlet controlled by a wall switch or pull cord to prevent the unit from being turned off accidentally.
- Avoid connecting unit to a Ground Fault Interrupter (GFI) circuit.

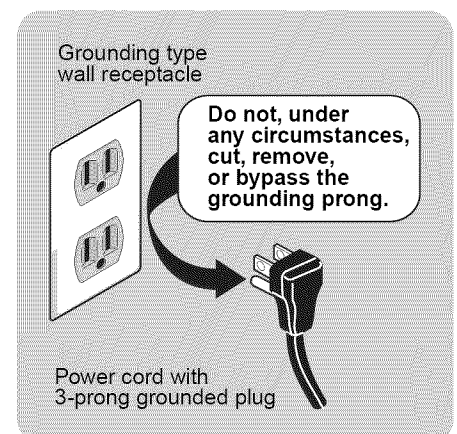

# Warranty Information

## Kenmore Appliance Warranty

### One Year Limited Warranty

When installed, operated and maintained according to all instructions supplied with the product, if this appliance fails due to a defect in material or workmanship within one year from the date of purchase, call 1-800-4-MY-HOME® to arrange for free repair.

If this appliance is used for other than private family purposes, this warranty applies for only 90 days from the date of purchase.

### **This warranty covers only defects in material and workmanship. Sears will NOT pay for:**

1. Expendable items that can wear out from normal use, including but not limited to filters, belts, light bulbs and bags.
2. A service technician to instruct the user in correct product installation, operation or maintenance.
3. A service technician to clean or maintain this product.
4. Damage to or failure of this product if it is not installed, operated or maintained according to all instructions supplied with the product.
5. Damage to or failure of this product resulting from accident, abuse, misuse or use for other than its intended purpose.
6. Damage to or failure of this product caused by the use of detergents, cleaners, chemicals or utensils other than those recommended in all instructions supplied with the product.
7. Damage to or failure of parts or systems resulting from unauthorized modifications made to this product.

### **Disclaimer of implied warranties; limitation of remedies**

Customer's sole and exclusive remedy under this limited warranty shall be product repair as provided herein. Implied warranties, including warranties of merchantability or fitness for a particular purpose, are limited to one year or the shortest period allowed by law. Sears shall not be liable for incidental or consequential damages. Some states and provinces do not allow the exclusion or limitation of incidental or consequential damages, or limitations on the duration of implied warranties of merchantability or fitness, so these exclusions or limitations may not apply to you.

This warranty applies only while this appliance is used in the United States and Canada.

This warranty gives you specific legal rights, and you may also have other rights which vary from state to state.

**Sears Brands Management Corporation, Hoffman Estates, IL 60179**

**Sears Canada Inc., Toronto, Ontario, Canada M5B 2C3**

# Master Protection Agreements

Congratulations on making a smart purchase. Your new Kenmore® product is designed and manufactured for years of dependable operation. But like all products, it may require preventive maintenance or repair from time to time. That's when having a Master Protection Agreement can save you money and aggravation. The Master Protection Agreement also helps extend the life of your new product. Here's what the Agreement\* includes:

- Parts and labor needed to help keep products operating properly under normal use, not just defects. Our coverage goes well beyond the product warranty. No deductibles, no functional failure excluded from coverage – real protection.
- Expert service by a force of more than 10,000 authorized Sears service technicians, which means someone you can trust will be working on your product.
- Unlimited service calls and nationwide service, as often as you want us, whenever you want us.
- “No-lemon” guarantee – replacement of your covered product if four or more product failures occur within twelve months.
- Product replacement if your covered product can't be fixed.
- Annual Preventive Maintenance Check at your request – no extra charge.
- Fast help by phone – we call it Rapid Resolution – phone support from a Sears representative on all products. Think of us as a “talking owner's manual”.
- Power surge protection against electrical damage due to power fluctuations.
- \$250 Food Loss Protection annually for any food spoilage that is the result of mechanical failure of any covered refrigerator or freezer.
- Rental reimbursement if repair of your covered product takes longer than promised.
- 10% discount off the regular price of any non-covered repair service and related installed parts.

Once you purchase the Agreement, a simple phone call is all that it takes for you to schedule service. You can call anytime day or night, or schedule a service appointment online.

The Master Protection Agreement is a risk free purchase. If you cancel for any reason during the product warranty period, we will provide a full refund. Or, a prorated refund anytime after the product warranty period expires. Purchase your Master Protection Agreement today!

Some limitations and exclusions apply. For prices and additional information in the U.S.A. call 1-800-827-6655.

\* Coverage in Canada varies on some items. For full details call Sears Canada at 1-800-361-6665.

## Sears Installation Service

For Sears professional installation of home appliances, garage door openers, water heaters, and other major home items, in the U.S.A. or Canada call 1-800-4-MY-HOME®.

# First Steps

This Use & Care Guide provides specific operating instructions for your model. Use the freezer only as instructed in this Use & Care Guide. Before starting the freezer, follow these important first steps.

## Installation

- Choose a place that is near a grounded electrical outlet. Do Not use an extension cord or an adapter plug.
- For the most efficient operation, the freezer should be located where surrounding temperatures will not exceed 110°F (43°C). Temperatures of 32°F (0°C) and below will NOT affect freezer operation. Additional compressor heaters are not recommended.
- Allow space around the unit for good air circulation. Leave a 3 inch (75 mm) space on all sides of the freezer for adequate circulation.

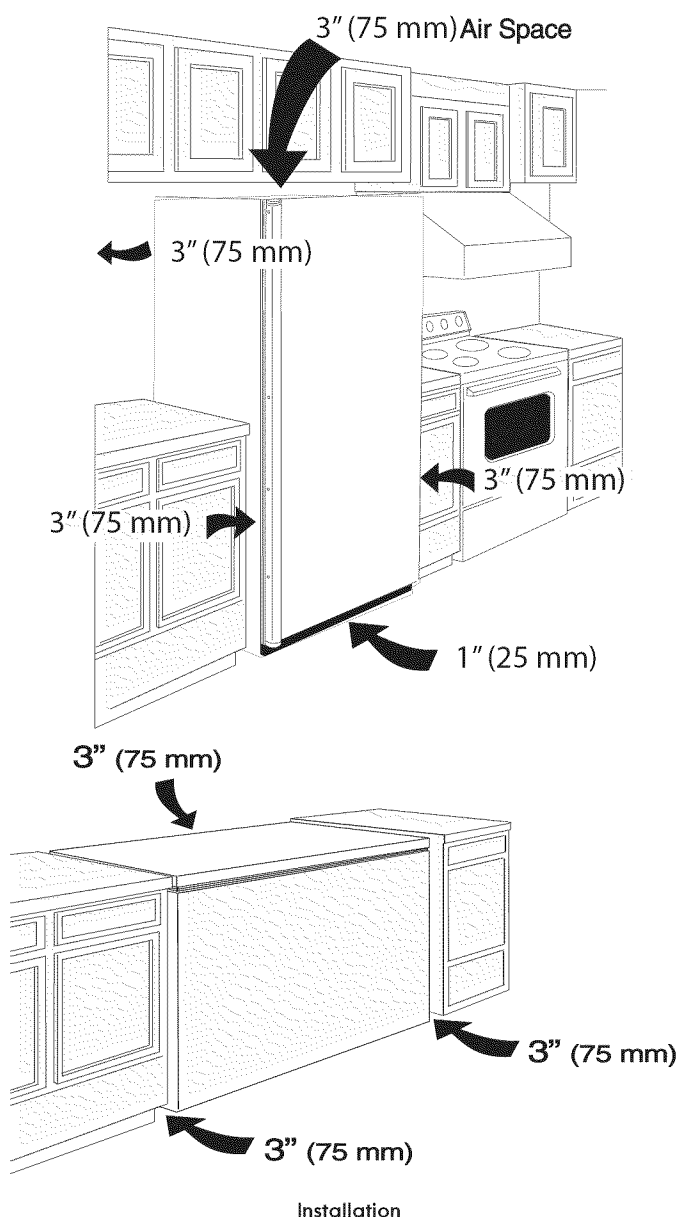

## NOTE

The exterior walls of the freezer may become quite warm as the compressor works to transfer heat from the inside. Temperatures as much as 30°F warmer than room temperature can be expected. For this reason it is particularly important in hotter climates to allow enough space for air circulation around your freezer.

## Leveling

The freezer must have all bottom corners resting firmly on a solid floor. The floor must be strong enough to support a fully loaded freezer. **NOTE:** It is Very Important for your freezer to be level in order to function properly. If the freezer is not leveled during installation, the door may be misaligned and not close or seal properly, causing cooling, frost, or moisture problems.

### To Level Upright Models:

After discarding crating screws and wood base, use a carpenter's level to level the freezer from front-to-back. Adjust the plastic leveling feet in front, 1/2 bubble higher, so that the door closes easily when left halfway open.

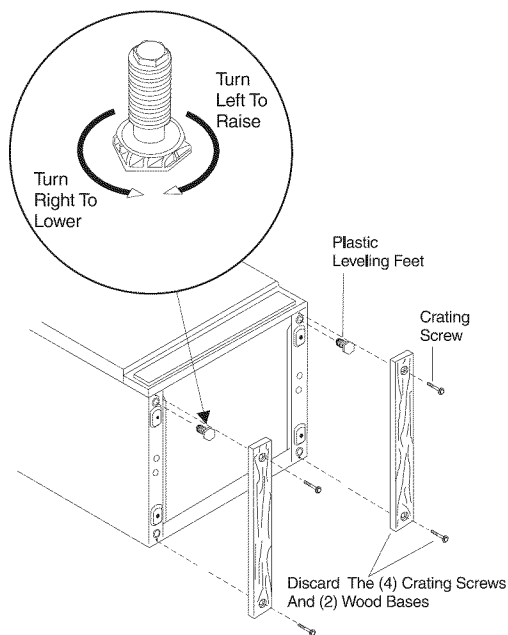

Unpacking and Leveling -- Upright Models

### To Level Chest Models:

If needed, add metal or wood shims between foot pads and floor.

## Cleaning (Prior to use)

- Wash any removable parts, the freezer interior, and exterior with mild detergent and warm water. Wipe dry. Do not use harsh cleaners on these surfaces.

## First Steps

- Do not use razor blades or other sharp instruments, which can scratch the appliance surface when removing adhesive labels. Any glue left from the tape can be removed with a mixture of warm water and mild detergent, or touch the residue with the sticky side of tape already removed. Do not remove the serial plate.



### CAUTION

To allow door to close and seal properly, **DO NOT** let food packages extend past the front of shelves.

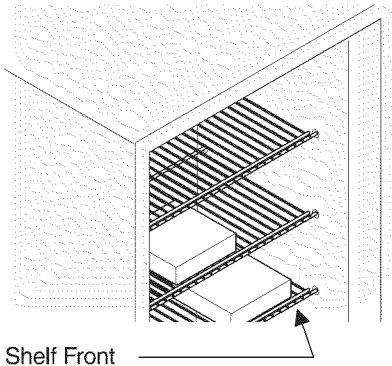

### Door Removal (non-electronic models)

If door must be removed:

1. Gently lay freezer on its back, on a rug or blanket.
2. Remove two base screws and base panel.
3. Remove bottom hinge screws.
4. Remove plastic top hinge cover.
5. Remove screws from top hinge.
6. Remove top hinge from cabinet.
7. Remove door and bottom hinge from cabinet.
8. To replace door, reverse the above order and securely tighten all screws to prevent hinge slippage.

### Door Removal (electronic models)

If door must be removed:

Door hinge is fastened with tamper-proof screws. Please have a qualified technician remove the door.

## Energy-saving Tips



- The freezer should be located in the coolest area of the room, away from heat producing appliances or heating ducts, and out of direct sunlight.
- Let hot foods cool to room temperature before placing in the freezer. Overloading the freezer forces the compressor to run longer. Foods that freeze too slowly may lose quality or spoil.
- Be sure to wrap foods properly, and wipe containers dry before placing them in the freezer. This cuts down on frost build-up inside the freezer.
- Freezer shelves should not be lined with aluminum foil, wax paper, or paper toweling. Liners interfere with cold air circulation, making the freezer less efficient.
- Organize and label food to reduce door openings and extended searches. Remove as many items as needed at one time, and close the door as soon as possible.

# Setting the Temperature Control

## Cool Down Period

- For safe food storage, allow four hours for the freezer to cool down completely. The freezer will run continuously for the first several hours. Foods that are already frozen may be placed in the freezer after the first few hours of operation. Unfrozen foods should NOT be loaded into the freezer until the freezer has operated for four hours.
- When loading the freezer, freeze only three pounds of fresh food per cubic foot of freezer space at one time. Distribute packages to be frozen evenly throughout the freezer. It is not necessary to turn the control knob to a colder setting while freezing food.

## Temperature Control

### Electromechanical Temperature Control (Chest and Some Upright Models)

The electromechanical temperature control is located inside the freezer on upright models, and on the left exterior wall on chest models (see figure 1). The temperature is factory preset to provide satisfactory food storage temperatures. However, the temperature control is adjustable to provide a range of temperatures for your personal satisfaction. To adjust the temperature setting, turn the temperature control knob clockwise or counterclockwise. Allow several hours for the temperature to stabilize between adjustments.

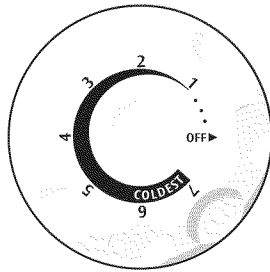

Electromechanical Control  
Figure 1

### Standard Electronic Temperature Control (Some Upright Frost Free Models)

The standard electronic temperature control is located outside the freezer (see Figure 2). Temperature is factory preset to provide satisfactory food storage temperatures. To adjust the temperature setting, press the UP (Λ) symbol for colder temperatures and DOWN (∇) symbol for warmer temperatures on the control panel. Allow several hours for the temperature to stabilize between adjustments.

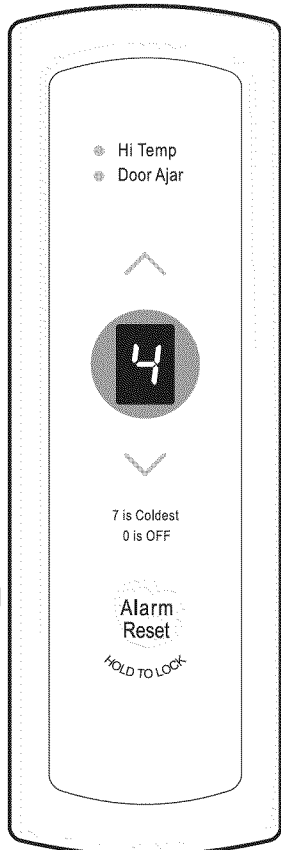

Standard Electronic  
Temperature Control  
Figure 2

To turn off freezer, press DOWN (∇) symbol until display shows "0". To activate freezer, press UP (Λ) until display shows "4" or desired setting.

To keep the temperature setting from being accidentally changed, the control may be locked. This is done by pressing "Alarm Reset" for 3 seconds. "L" will then appear on display. To unlock the control, press "Alarm Reset" for 3 seconds. For the first second, "U" will appear, and then the current temperature will appear.

### Deluxe Electronic Temperature Control (Some Upright Frost Free Models)

Refer to the Electronics Control Guide supplied when you purchase a deluxe electronic upright model. See Figure 3 for deluxe electronics control panel.

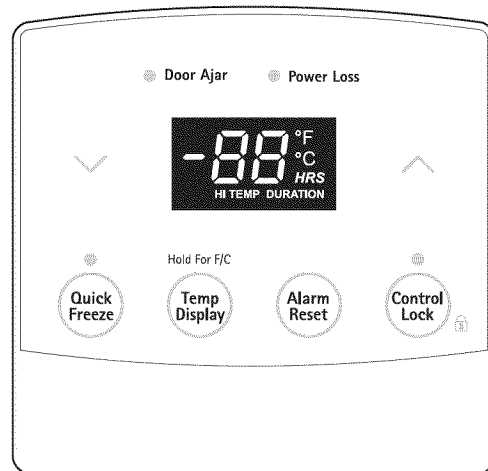

Upright Models  
Figure 3



# Optional Features

## NOTE

Your freezer may have some, or all of the features listed below. Become familiar with these features, and their use and care.

### Security Lock with Pop-Out Key

This security lock fastens the door snugly, ensuring stored food is secure. To lock or unlock the freezer, push the key into the lock and turn. The key pops out of the lock after it has been turned.

### Blue Defrost Button (some chest models)

## IMPORTANT

It is time to defrost and clean the freezer when the blue defrost button is completely covered with frost.

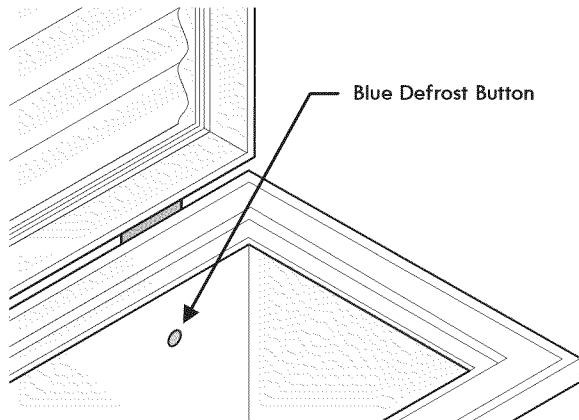

### Manual Defrost Mode

To initiate a 30-minute manual defrost cycle, turn the freezer off by pressing the “DOWN” button until a “0” appears in the display indicating “Off”.

Press the “DOWN” button 4 times until a “d” appears in the display indicating “defrost”.

To exit the Manual Defrost Mode, press the “DOWN” button 4 times. The “d” will no longer be displayed. The control may then be operated normally to set the freezer temperature.

### Control Troubleshooting

Should your freezer control display unusual characters, or operate incorrectly due to power surges, brown-outs, power interruptions, area lighting, etc.:

Unplug the freezer from the wall outlet.

1. Wait one (1) minute.
2. Plug the freezer back into the wall outlet.

The control will perform a self-check, reset itself, and return to normal operation. Should the condition persist, contact your Service provider.

### Temp Alarm

This feature is designed to provide a warning if the inside temperature exceeds 23°F. “HI TEMP” feature operates on household electricity. It will not function if household electricity is interrupted.

When the freezer is initially plugged in, the red “HI TEMP” indicator will be on and the buzzer will sound. The indicator

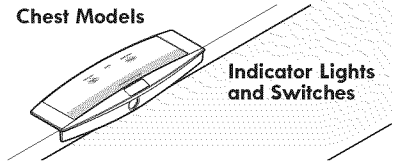

light will stay on until the freezer temperature is below 23°F. To silence the buzzer, press the ALARM RESET button.

If a malfunction causes the temperature inside the freezer to rise above 23°F, the “HI TEMP” light will turn on and the buzzer will sound. The buzzer will sound every hour until the freezer temperature is below 23°F. To silence the buzzer, press the ALARM RESET button.

Should an “E” appear on display, contact your authorized service technician for repair. Until changes are made, freezer will continue to run.

Alarm Function Table		
Except during power loss, the red alarm light illuminates whenever there is an alarm status.		
Display Status	Function	Response
Cabinet temperature is displayed.	Normal Operation	None
FF is displayed.	Quick Freeze	None
Temperature flashing on and off. Control panel beeps every 5 seconds.	Freezer temperature too high	Check power is connected. Contact service technician. Press ALARM RESET to shut off audible alarm (beep).
Alternating: “b” and temperature. Control panel beeps every 5 seconds.	Low/no battery	Replace 9V battery. Press ALARM RESET to stop audible alarm (beep).
Alternating: “d” and temperature. Control panel beeps every 5 seconds.	Door ajar	Close door. Press ALARM RESET to stop audible alarm (beep).
Alternating: “E” and temperature. Control panel beeps every 5 seconds.	Operational error	Contact service technician. Press ALARM RESET to stop audible alarm (beep).
Alternating: “CE” and temperature. Control panel beeps every 5 seconds.	Operational error	Contact service technician. Press ALARM RESET to stop audible alarm (beep).
Display off. Control panel beeps every minute	Power failure	Reconnect power connection.

# Optional Features

## Slide-Out Basket (some upright models)

A Slide-Out Basket (some models), located at the bottom of the freezer, provides separate storage space for items that are difficult to store on freezer shelves. To remove the basket, pull out and lift up.

## Interior Light

The light comes on automatically when the door is opened. To replace the light bulb, turn the temperature control to OFF and unplug the electrical cord. Replace the old bulb with a bulb of the same wattage.

## Tilt-Out Shelf

This shelf is located inside on the freezer door and provides additional storage space. To access an item, tilt top of "basket" shelf down.

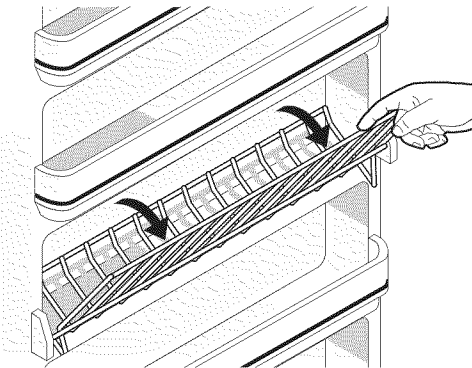

Tilt-Out Shelf

## Adjustable Door Bins (some upright models)

Adjustable door bins are located on the inside on the freezer door and provide flexible storage space. The number of bins provided varies by model.

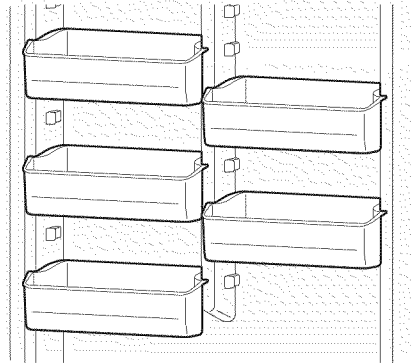

Adjustable Door Bins

## Soft Freeze Zone (some upright models)

Soft Freeze Zone is specifically designed to maintain a higher temperature than the rest of the freezer to store products such as ice cream.

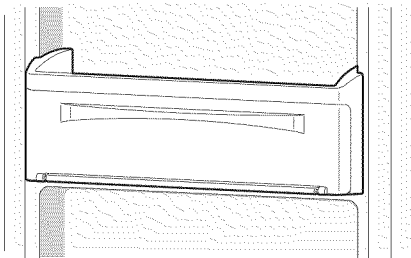

Soft Freeze Zone

## Adjustable Interior Shelves (some upright models)

Multi-position adjustable interior shelves can be moved to any position for larger or smaller packages. The shipping spacers that stabilize the shelves for shipping may be removed and discarded.

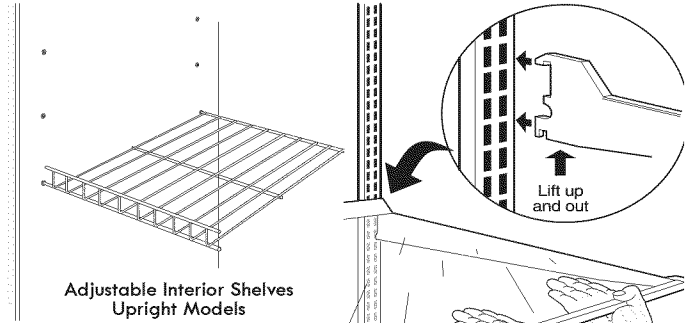

Adjustable Interior Shelves Upright Models

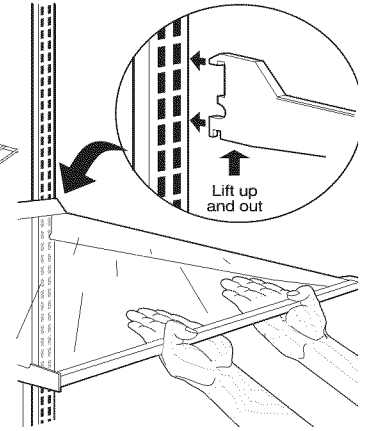

Adjustable Interior Shelves Upright Models

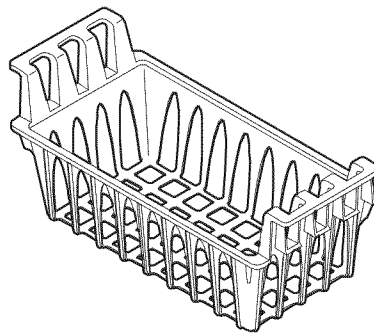

Slide-Aside Basket

## Slide-Aside Basket (some chest models)

This basket helps organize odd-shaped items. To reach other packages in the freezer, slide the basket aside, or lift out.

## Basket Divider (some upright models)

Use these handy dividers to keep the various items stored in your baskets more organized. To change the location of the divider simply slide your basket out, grab the divider from the center and rotate in a counterclockwise direction until it is disengaged. To assemble, simply align as shown in the figure below and rotate in a clockwise direction until it swings into place.

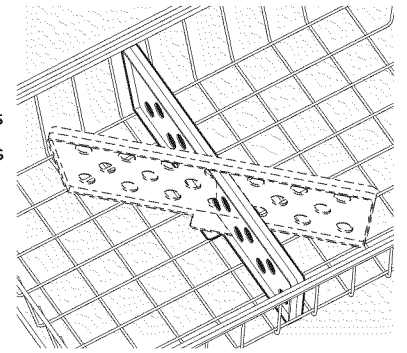

Basket Divider

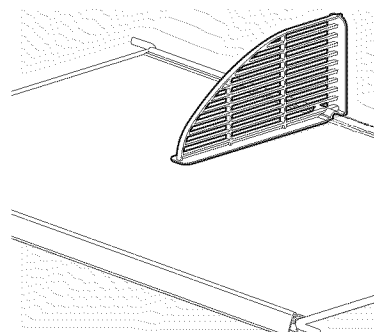

Shelf Bookend

## Shelf Bookend (some upright models)

## Glass Shelf Bookend

Use these handy bookends to keep the boxed items stored neatly in your freezer. To adjust location, simply slide where desired.

## Optional Features

### Wire Shelf Bookend

Use these bookends to keep the boxed items stored neatly in your freezer. To adjust location, simply unsnap the bookend from the wire shelf and snap into the next desired location.

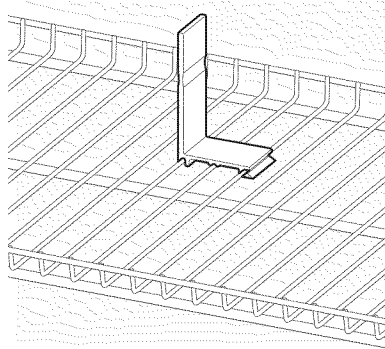

Wire Shelf Bookend

### Pizza Shelf (some upright models)

Here is the place to store up to four large frozen pizzas without ever having to dig them out from beneath a pile of other stored goods.

The pizza shelf can be retracted to provide space for taller items on the shelf below, and still store up to two pizzas.

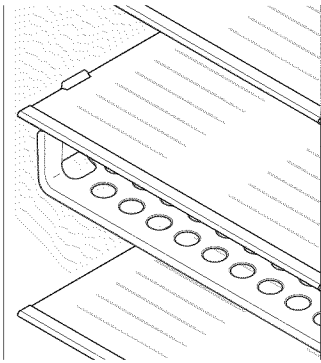

Pizza Shelf

### Chest Divider

(some chest models)

Use these clever dividers to custom-arrange a variety of different-sized storage bins in the bottom of your chest freezer.

Use the peel-n-stick labels found in your literature packet to help remind you which items are stored where. If you have an item that isn't already covered by one of the pre-printed labels then use one of the blank labels and a permanent marking pen to make your own custom label. Labels can be peeled off when no longer needed and replaced by new and different ones.

Examples of Chest Divider

Configurations:

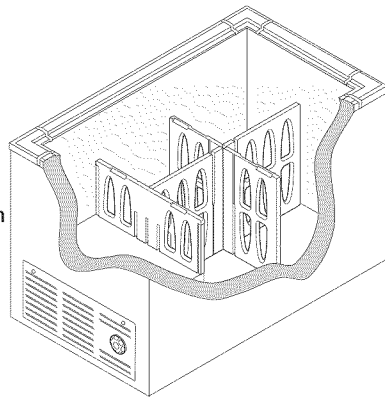
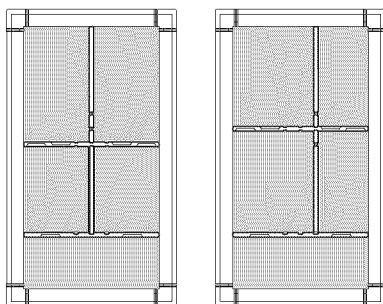

Chest Divider

## Care and Cleaning

### CAUTION

Damp objects stick to cold metal surfaces. Do not touch inferior metal surfaces with wet or damp hands.

Some upright freezers are frost-free and defrost automatically, but should be cleaned occasionally.

### Between Defrostings

To avoid frequent defrosting, occasionally use a plastic scraper to remove frost. Scrape with a pulling motion. Never use a metal instrument to remove frost.

### Defrostings

### CAUTION

Freezer must be unplugged (to avoid electrical hazard) from power source when defrosting unit.

It is important to defrost and clean the freezer when  $\frac{1}{4}$  to  $\frac{1}{2}$  inch of frost has accumulated. Frost may tend to accumulate faster on the upper part of the freezer due to warm, moist air entering the freezer when the door is opened. Remove food and leave the door open when defrosting the freezer.

### To Defrost Upright Models with Defrost Drain:

- Remove the drain plug on the inside floor of the freezer by pulling it straight out.
- To access external drain tube on models with a base panel, first remove the two screws from the base panel. Locate the drain tube near the left center under the freezer.
- Place a shallow pan under the drain tube. Defrost water will drain out. Check the pan occasionally so water does not overflow (see figure 1).
- A  $\frac{1}{2}$  inch garden hose adapter can be used to drain the freezer directly into a floor drain. If your model is not equipped with an adapter, one can be purchased at most hardware stores.
- Replace the drain plug when defrosting and cleaning are completed. If the drain is left open, warm air may enter the freezer.

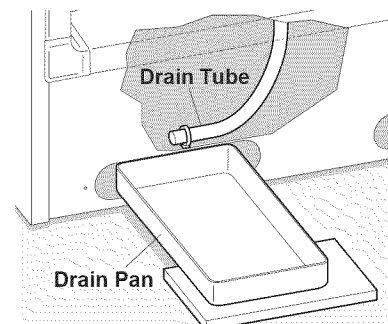

Figure 1

# Care and Cleaning

## To Defrost Chest Models with Defrost Drain:

- Place a shallow pan or the Divider/Drain Pan (if equipped) beneath the drain outlet. Pull out the outside drain plug (see figure 2). A ½ inch garden hose adaptor can be used to drain the freezer directly into a floor drain (see figure 3). If your model is not equipped with an adaptor, one can be purchased at most hardware stores.
- Pull out the drain plug inside the freezer (see figure 4). Defrost water will drain out. Check pan occasionally so water does not overflow.
- Replace the drain plugs when defrosting and cleaning are completed. If the drain is left open, warm air may enter the freezer.

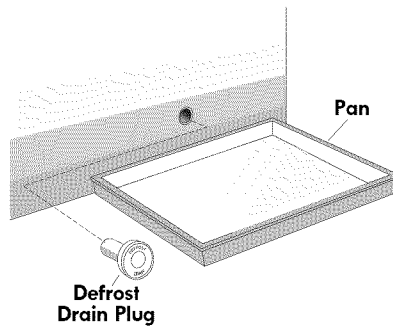

Figure 2

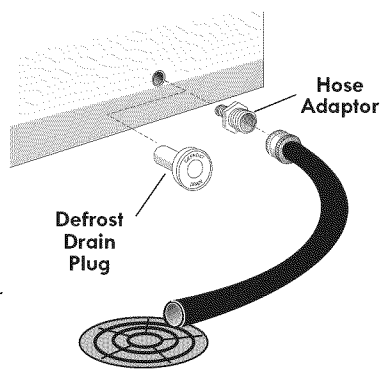

Figure 3

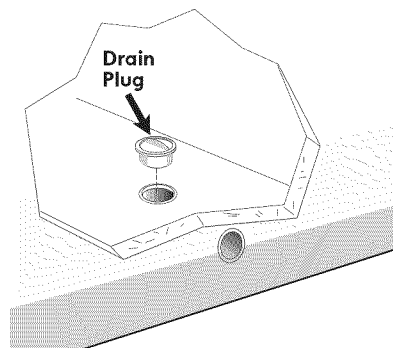

Figure 4

## To Defrost Models without Defrost Drain:

- Place towels or newspapers on the freezer bottom to catch the frost. The frost will loosen and fall.
- Remove the towels and/or newspapers.
- If the frost is soft, remove it by using a plastic scraper. If the frost is glazed and hard, fill deep pans with hot water and place them on the freezer bottom.
- Close the freezer door/lid. Frost should soften in about fifteen (15) minutes.
- Repeat this procedure is necessary.

## Cleaning the Inside

After defrosting, wash inside surfaces of the freezer with a solution of two tablespoons of baking soda in one quart (1.1 litres) warm water. Rinse and dry. Wring excess water out of the sponge or cloth when cleaning in the area of the controls, or any electrical parts.

Wash the removable parts and door basket with the baking soda solution mentioned above, or mild detergent and warm water. Rinse and dry. **Never** use metallic scouring pads, brushes, abrasive cleaners, or alkaline solutions on any surface. Do not wash removable parts in a dishwasher.

## Cleaning the Outside

Wash the cabinet with warm water and mild liquid detergent. Rinse well and wipe dry with a clean soft cloth. Replace parts and food.



### WARNING

If leaving the freezer door open while on vacation, make certain that children cannot get into the freezer and become entrapped.

## Vacation and Moving Tips

**Short Vacations:** Leave the freezer operating during vacations of less than three weeks.

**Long Vacations:** If the freezer will not be used for several months:

- Remove all food and unplug the power cord.
- Clean and dry the interior thoroughly.
- Leave the freezer door open slightly, blocking it open if necessary, to prevent odor and mold growth.

**Moving:** When moving the freezer, follow these guidelines to prevent damage:

- Disconnect the power cord plug from the wall outlet.
- Remove foods, then defrost, and clean the freezer.
- Secure all loose items such as base panel, baskets, and shelves by taping them securely in place to prevent damage.
- In the moving vehicle, secure freezer in an upright position to prevent movement. Also protect outside of freezer with a blanket, or similar item.

## Power Failure/Freezer Failure

### NOTE

Do not open freezer door unnecessarily if freezer is off for several hours.

If a power failure occurs, frozen foods will stay frozen for at least 24 hours if the freezer is kept closed. If the power failure continues, pack seven or eight pounds of dry ice into the freezer every 24 hours. Look in the Yellow Pages under Dry Ice, Dairies, or Ice Cream manufacturers for local dry ice suppliers. Always wear gloves and use caution when handling dry ice.

If the freezer has stopped operating, see “Freezer Does Not Run” in the Troubleshooting Guide. If you cannot solve the problem, call an authorized servicer mediately.

If the freezer remains off for several hours, follow the directions above for the use of dry ice during a power failure. If necessary, take the food to a local locker plant until the freezer is ready to operate. Look in the Yellow Pages under “Frozen Food Locker Plants”.

# Before You Call

<b>TROUBLESHOOTING GUIDE</b>		
Before calling for service, review this list. It may serve you time and expense. This list includes common occurrences that are not the result of defective workmanship or materials in this appliance.		
<b>CONCERN</b>	<b>POTENTIAL CAUSE</b>	<b>COMMON SOLUTION</b>
<b>FREEZER DOES NOT RUN</b>		
Freezer does not run.	<ul style="list-style-type: none"> <li>Freezer is plugged into a circuit that has a ground fault interrupt</li> <li>Temperature control is in the OFF position.</li> <li>Freezer may not be plugged in or plug may be loose.</li> <li>House fuse blown or tripped circuit breaker.</li> <li>Power outage.</li> </ul>	<ul style="list-style-type: none"> <li>Use another circuit. If you are unsure about the outlet, have it checked by a certified technician.</li> <li>See Setting the Temperature Control Section.</li> <li>Ensure plug is tightly pushed into outlet.</li> <li>Check/replace fuse with a 15 amp time-delay fuse. Reset circuit breaker.</li> <li>Check house lights. Call local Electric Company.</li> </ul>
Freezer runs too much or too long.	<ul style="list-style-type: none"> <li>Room or outside weather is hot.</li> <li>Freezer has recently been disconnected for a period of time.</li> <li>Large amounts of warm or hot food have been stored recently.</li> <li>Doors are opened too frequently or too long.</li> <li>Freezer door may be slightly open.</li> <li>Temperature Control is set too low.</li> <li>Freezer gasket is dirty, worn, cracked, or poorly fitted.</li> </ul>	<ul style="list-style-type: none"> <li>It's normal for the freezer to work harder under these conditions.</li> <li>It takes 4 hours for the freezer to cool down completely.</li> <li>Warm food will cause freezer to run more until the desired temperature is reached.</li> <li>Warm air entering the freezer causes it to run more. Open doors less often.</li> <li>See "DOOR PROBLEMS" Section.</li> <li>Turn control knob to a warmer setting. Allow several hours for the temperature to stabilize.</li> <li>Clean or change gasket. Leaks in the door seal will cause freezer to run longer in order to maintain desired temperature.</li> </ul>
Interior Freezer temperature is too cold.	<ul style="list-style-type: none"> <li>Temperature Control is set too low.</li> </ul>	<ul style="list-style-type: none"> <li>Turn the control to a warmer setting. Allow several hours for the temperature to stabilize.</li> </ul>
Interior Freezer temperature is too warm.	<ul style="list-style-type: none"> <li>Temperature Control is set too warm.</li> <li>Door is kept open too long or is opened too frequently.</li> <li>Door may not be seating properly.</li> <li>Large amounts of warm or hot food may have been stored recently.</li> <li>Freezer has recently been disconnected for a period of time.</li> </ul>	<ul style="list-style-type: none"> <li>Turn control to a colder setting. Allow several hours for the temperature to stabilize.</li> <li>Warm air enters the freezer every time the door is opened. Open the door less often.</li> <li>See "DOOR PROBLEMS" Section.</li> <li>Wait until the freezer has had a chance to reach its selected temperature.</li> <li>Freezer requires 4 hours to cool down completely.</li> </ul>
Freezer external surface temperature is warm.	<ul style="list-style-type: none"> <li>The external freezer walls can be as much as 30°F warmer than room temperature.</li> </ul>	<ul style="list-style-type: none"> <li>This is normal while the compressor works to transfer heat from inside the freezer cabinet.</li> </ul>
<b>SOUND AND NOISE</b>		
Louder sound levels whenever freezer is on.	<ul style="list-style-type: none"> <li>Modern freezers have increased storage capacity and more stable temperatures. They require a high efficiency compressor.</li> </ul>	<ul style="list-style-type: none"> <li>This is normal. When the surrounding noise level is low, you might hear the compressor running while it cools the interior.</li> </ul>
Longer sound levels when compressor comes on.	<ul style="list-style-type: none"> <li>Freezer operates at higher pressures during the start of the ON cycle.</li> </ul>	<ul style="list-style-type: none"> <li>This is normal. Sound will level off or disappear as freezer continues to run.</li> </ul>

## Before You Call

CONCERN	POTENTIAL CAUSE	COMMON SOLUTION
<b>SOUND AND NOISE</b>		
<b>Popping or cracking sound when compressor comes on.</b>	<ul style="list-style-type: none"> <li>• Metal parts undergo expansion and contraction, as in hot water pipes.</li> </ul>	<ul style="list-style-type: none"> <li>• This is normal. Sound will level off or disappear as freezer continues to run.</li> </ul>
<b>Bubbling or gurgling sound, like water boiling.</b>	<ul style="list-style-type: none"> <li>• Refrigerant (used to cool freezer) is circulating throughout the system.</li> </ul>	<ul style="list-style-type: none"> <li>• This is normal.</li> </ul>
<b>Vibrating or rattling noise.</b>	<ul style="list-style-type: none"> <li>• Freezer is not level. It rocks on the floor when it is moved slightly.</li> <li>• Floor is uneven or weak. Freezer rocks on floor when it is moved slightly.</li> <li>• Freezer is touching the wall.</li> </ul>	<ul style="list-style-type: none"> <li>• Level the unit. Refer to “Leveling” in the First Steps Section.</li> <li>• Ensure floor can adequately support freezer. Level the freezer by putting wood or metal shims under part of the freezer.</li> <li>• Re-level the freezer or move freezer slightly. Refer to “Leveling” in the First Steps Section.</li> </ul>
<b>WATER/MOISTURE/FROST INSIDE FREEZER</b>		
<b>Moisture forms on inside freezer walls.</b>	<ul style="list-style-type: none"> <li>• Weather is hot and humid, which increases internal rate of frost build-up.</li> <li>• Door may not be seating properly.</li> <li>• Door is kept open too long, or is opened too frequently</li> </ul>	<ul style="list-style-type: none"> <li>• This is normal.</li> <li>• See “DOOR PROBLEMS” Section.</li> <li>• Open the door less often.</li> </ul>
<b>WATER/MOISTURE/FROST OUTSIDE FREEZER</b>		
<b>Moisture forms on outside of freezer.</b>	<ul style="list-style-type: none"> <li>• Door may not be seating properly, causing the cold air from inside the freezer to meet warm moist air from outside.</li> </ul>	<ul style="list-style-type: none"> <li>• See “DOOR PROBLEMS” Section.</li> </ul>
<b>ODOR IN FREEZER</b>		
<b>Odors in freezer</b>	<ul style="list-style-type: none"> <li>• Interior needs to be cleaned.</li> <li>• Foods with strong odors are in the freezer.</li> </ul>	<ul style="list-style-type: none"> <li>• Clean interior with sponge, warm water, and baking soda.</li> <li>• Cover the food tightly.</li> </ul>
<b>DOOR PROBLEMS</b>		
<b>Door will not close.</b>	<ul style="list-style-type: none"> <li>• Freezer is not level. It rocks on the floor when it is moved slightly.</li> <li>• Floor is uneven or weak. Freezer rocks on floor when it is moved slightly</li> </ul>	<ul style="list-style-type: none"> <li>• This condition can force the cabinet out of square and misalign the door. Refer to “Leveling” in the First Steps Section.</li> <li>• Level the floor by using wood or metal shims under the freezer or brace floor supporting the freezer.</li> </ul>
<b>LIGHT BULB IS NOT ON</b>		
<b>Light bulb is not on.</b>	<ul style="list-style-type: none"> <li>• Light bulb is burned out.</li> <li>• No electric current is reaching the freezer.</li> </ul>	<ul style="list-style-type: none"> <li>• Follow directions under “Interior Light” in the Freezer Features Section.</li> <li>• See “FREEZER DOES NOT RUN” Section.</li> </ul>

## Sears Service

"We Service What We Sell" is our assurance you can depend on Sears for service... and Sears service is nationwide. Your freezer has added value when you consider that Sears has service units nationwide, staffed with professional technicians specifically trained on Sears appliances and having parts, tools and equipment to ensure that we meet our pledge to you... "We Service What We Sell".

### Sears Maintenance Agreement

Maintain the value of your Kenmore® freezer with a Sears Maintenance Agreement. Sears freezers are designed, manufactured, and tested for years of dependable operation. Yet any modern appliance may require service from time to time.

#### The Sears Maintenance Agreement

- Is your way to buy tomorrow's service at today's price.
- Eliminates repair bills resulting from normal use.
- Allows for as many service calls as required.
- Provides for service by professional Sears-trained technicians.
- Offers an annual preventive maintenance check up at your request.

This maintenance agreement does not cover original installation, reinstallation, or damage resulting from external causes such as acts of God, abuse, theft, fire, flood, wind, lightning, freezing, power failure, power reduction, etc. Please ask a salesperson to see the agreement for all terms and conditions.

## Sears Canada Customers

### Dear Customer:

In manufacturing this product, many steps have been taken to provide you with the highest quality. Unfortunately, errors or omissions occasionally occur. In the event you find a missing or defective part, please contact your nearest Sears store.

If you have any suggestions that would help us to improve our assembly/operation instructions or this product, please write them down, including the information listed below and mail to:

**Sears Canada, Inc.**

**Attn.: Buyer Dept. 646**

**22 Jarvis Street**

**Toronto, CA**

**M5B 2B8**

Purchased by:

Name: \_\_\_\_\_

Address: \_\_\_\_\_

City: \_\_\_\_\_ Prov.: \_\_\_\_\_

Postal Code: \_\_\_\_\_ Phone: \_\_\_\_\_

Model No.: 970 \_\_\_\_\_

Serial No.: \_\_\_\_\_

Date of Purchase \_\_\_\_\_/\_\_\_\_\_/\_\_\_\_\_

Location of Purchase: \_\_\_\_\_

Comments: \_\_\_\_\_

---

---

---

---