



## Models

**XEB-2**

**XEB-3**

**XEB-4**

**XEB-5**

**XEB-6**

**XEB-7**

## XEB Series II

Gas-Fired Hot Water  
Induced Draft Boilers

## INSTALLATION, OPERATION & MAINTENANCE MANUAL

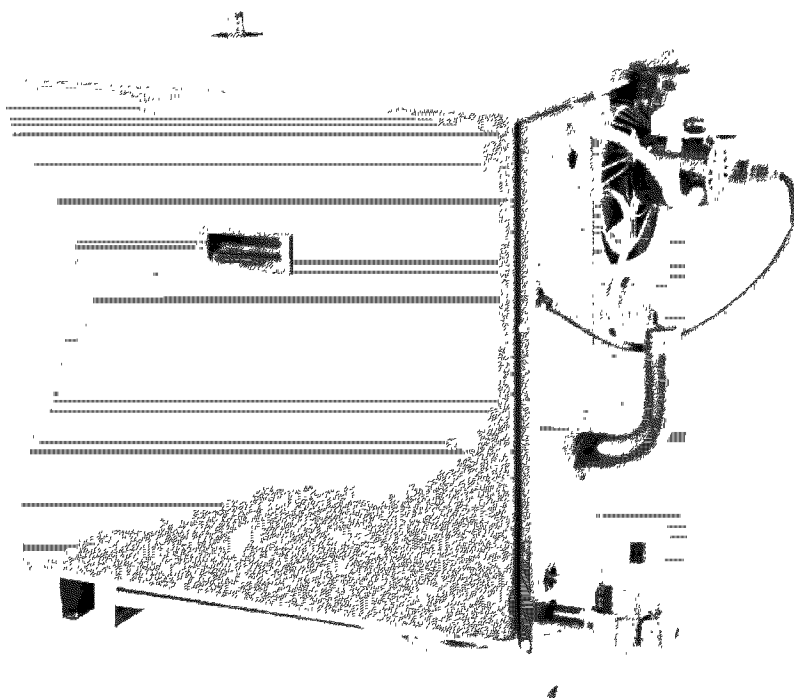

C S A Certified  
For Natural Gas Or Propane

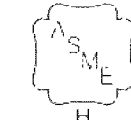

H  
Tested For 50 psi  
ASME  
Working Pressure



**Manufactured by:**

**ECR International, Inc.**

2201 Dwyer Avenue, Utica NY 13501

web site: [www.ecrinternational.com](http://www.ecrinternational.com)

P/N 240009020 Rev B [04/2012]

TABLE OF CONTENTS

**Boiler Ratings & Capacities..... 3**  
**Dimensions ..... 4**  
**Installation Procedure..... 5**  
**Ventilation & Combustion Air ..... 6**  
**Installation System Piping ..... 7**  
**Vent Installation ..... 10**  
**Horizontal Venting Instructions ..... 13**  
**Optional Horizontal Venting Instruction 18**  
**Gas supply Piping..... 19**  
**Electrical Wiring ..... 21**  
**Sequence of Operation ..... 22**  
**Wiring Diagrams ..... 23**  
**Starting Your Boiler..... 24**  
**Checking and Adjusting..... 26**  
**Maintaining Your Boiler ..... 28**  
**Service Hints ..... 29**  
**Equipment & Optional Accessories ..... 30**  
**Appendix A - Control Module ..... 32**  
A.1 Installation Environment Considerations. 32  
A.2 Electrical Connections..... 32  
A.3 Adjusting Settings..... 32  
A.4 Display ..... 32  
A.5 Operation ..... 33  
A.6 Boiler High Limit Temperature Controller 34  
A.7 Troubleshooting ..... 34  
A.8 Troubleshooting Error Codes..... 34  
A.9 Intermittent Pilot ..... 35

**KEEP THIS MANUAL NEAR BOILER  
RETAIN FOR FUTURE REFERENCE**

**Safety Symbols & Warnings**

The following defined symbols are used throughout this manual to notify the reader of potential hazards of varying risk levels.

**⚠ DANGER**  
Indicates a hazardous situation which, if not avoided, WILL result in death or serious injury

**⚠ WARNING**  
Indicates a hazardous situation which, if not avoided, could result in death or serious injury.

**⚠ CAUTION**  
Indicates a hazardous situation which, if not avoided, could result in minor or moderate injury.

**NOTICE**  
Used to address practices not related to personal injury.

**IMPORTANT: Read the following instructions  
COMPLETELY before installing!!**

**⚠ WARNING**  
Fire, explosion, asphyxiation and electrical shock hazard. Improper installation could result in death or serious injury. Read this manual and understand all requirements before beginning installation.

**⚠ WARNING**  
Keep boiler area clear and free from combustible materials, gasoline and other flammable vapors and liquids.  
DO NOT obstruct air openings to the boiler room. Modification, substitution or elimination of factory equipped, supplied or specified components may result in personal injury or loss of life.  
TO THE OWNER - Installation and service of this boiler must be performed by a qualified installer.  
TO THE INSTALLER - Leave all instructions with boiler for future reference.  
When this product is installed in the Commonwealth of Massachusetts the installation must be performed by a Licensed Plumber or Licensed Gas Fitter.



**Table 1 - RATINGS NATURAL AND PROPANE GASES**

Model	Input *Mbh	Heating Capacity *Mbh	**Net AHRI Rating Water *Mbh	AFUE	Vent Diameter (Inches)	
					To Chimney (Category I)	Horizontal Vent (Category III)
XEB-2	42.5	36	31	84.4	4	3
XEB-3	75.0	63	55	83.4	4	3
XEB-4	112.5	94	82	83.0	4	3
XEB-5	150.0	125	109	82.7	4	3
XEB-6	187.5	155	135	82.3	4	4
XEB-7	225.0	186	162	82.0	4	4

\* MBH = 1,000 Btuh = British Thermal Unit Per Hour. Boilers are equipped for altitudes up to 2,000 feet only. U.S.A. Only - For altitudes above 2,000 feet, ratings should be reduced at the rate of 4% for each 1,000 feet above sea level. Canada Only - Boilers may be used at high altitude (2,000-4500 feet/640-1350m) by using a certified field conversion kit, resulting in a 10% de-rate. Contact Provincial authority having jurisdiction for installations above 4500 ft (1350m) above sea level. + Heating Capacity based on D.O.E. (Department of Energy) test procedure.

\*\*Net AHRI Water Ratings indicate amount of remaining heat input that can be used to heat the radiation or terminal units. Net AHRI Ratings shown are based on an allowance of 1.15 Selection of boiler size should be based upon "Net AHRI Rating" being equal to or greater than calculated heat loss of building.

Manufacturer should be consulted before selecting a boiler for installations having unusual piping and pickup requirements.

**New York City MEA Number 484-84-E Vol. IV.**

This boiler cannot be used with all types of chimneys. Read these instructions carefully before installing.

These Gas-Fired Hot Water Boilers are low pressure, sectional cast iron boilers Design Certified by C.S.A. (Canadian Standards Association) for use with Natural and Propane Gases. Constructed and hydrostatically tested for maximum working pressure of 50 psi in accordance with A.S.M.E. Boiler and Pressure Vessel Code Section IV Standards for cast iron heating boilers.

Boilers must stand on noncombustible floor. If installed on combustible floor, please refer to Repair Parts manual for appropriate Combustible Floor Base part number.

**Boilers For Use At High Altitude**

Boiler is factory equipped for use at altitudes of 0-2,000 feet above sea level. For use at altitudes above 2,000 feet above sea level, input ratings are reduced by change in main burner orifice size. **U.S.A.** For altitudes above 2,000 feet above sea level, input ratings should be reduced at rate of 4% for each 1,000 feet above sea level. Consult National Fuel Gas Code (NFPA54/ANSI Z223.1), or manufacturer for correct orifice sizing information. High altitude orifices are available from boiler manufacturer.

## DIMENSIONS

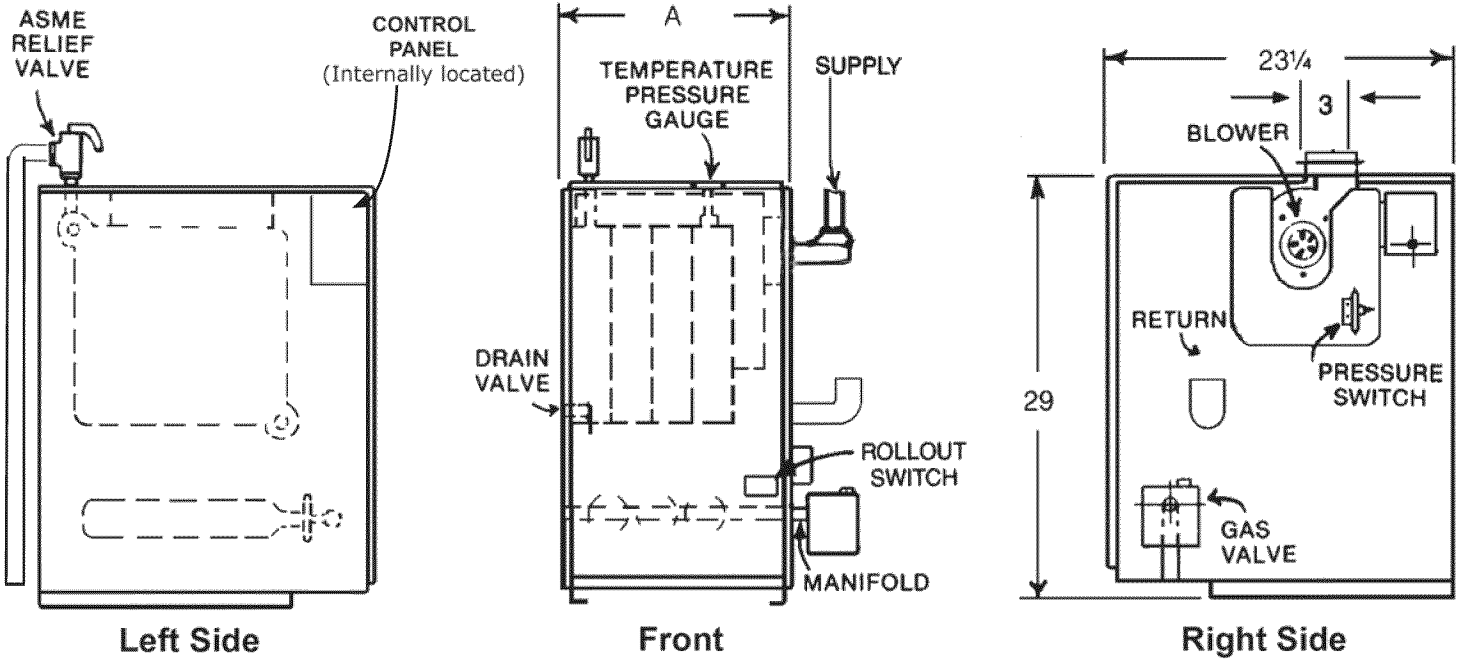

Model	Width (A)
XEB-2	11
XEB-3	14-1/4
XEB-4	17-1/2
XEB-5	20-3/4
XEB-6	24
XEB-7	27-1/4



## INSTALLATION PROCEDURE

### ⚠ WARNING

Improper installation, adjustment, alteration, service or maintenance could result in death or serious injury.

1. Installation must conform to requirements of authority having jurisdiction or, in absence of such requirements, to the National Fuel Gas Code, ANSI Z223.1/NFPA 54.
2. Where required by authority having jurisdiction, installation must conform to the Standard for Controls and Safety Devices for Automatically fired Boilers, ANSI/ASME CSD-1.
3. Boiler series is classified as Category I. Vent installation shall be in accordance with "Venting of Equipment," of the National Fuel Gas Code, ANSI Z223.1/NFPA 54, or applicable provisions of local building codes.
4. Boiler has met safe lighting and other performance criteria with gas manifold and control assembly on boiler per latest revision of ANSI Z21.13/CGA 4.9.
5. Install such that gas ignition system components are protected from water (dripping, spraying, rain, etc.) during appliance operation and service, (circulator replacement, condensate trap, control replacement, etc.).
6. Locate boiler on level, solid base as near chimney as possible and centrally located with respect to heat distribution system as practical.
7. Verify you have the right size boiler before starting installation. See rating and capacity table.
8. When installed in utility room, door should be wide enough to allow largest boiler part to enter, or to permit replacement of another appliance such as water heater.
9. Boiler installed in building under construction, take care to insure clean combustion air supply during construction process. Airborne particulates such as from drywall dust and from fiberglass insulation can clog burner ports and cause incomplete combustion and sooting.

### ⚠ WARNING

Fire hazard. Do not install boiler on combustible flooring or carpeting. Failure to follow these instructions could result in death or serious injury.

10. **FOR INSTALLATION ON NON-COMBUSTIBLE FLOORS ONLY** - For installation on combustible flooring special base must be used. (See Replacement Parts Section.) **Do Not Install Boiler on carpeting.**
11. Verify boiler is supplied with correct type of gas, fresh air for combustion, and suitable electrical supply.

### NOTICE

Follow local regulations with respect to installation of CO detectors.

**Figure 1 - Minimum Clearances To Combustible Construction**

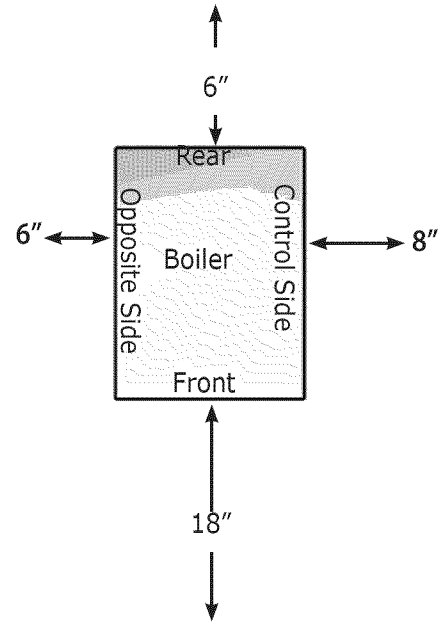

**Table 1 - BOILER MINIMUM CLEARANCE TO COMBUSTIBLES**

Unit	Minimum Clearances
Top	6" (152mm)
Rear	6" (152mm)
Control Side	8" (203mm)
Opposite Side	6" (152mm)
Front (Alcove)	18" (457mm)
Flue/Vent Connector	6" (152mm)
Near Boiler Piping	1" (24mm)

**Set unit on concrete or other noncombustible material base or floor. DO NOT INSTALL ON CARPETING.**

## VENTILATION & COMBUSTION AIR

Provide combustion air and ventilation air in accordance with the section "Air for Combustion and Ventilation," of the National Fuel Gas Code, ANSI Z223.1/NFPA 54, or Sections 8.2, 8.3 or 8.4 of Natural Gas and Propane Installation Code, CAN/CSA B149.1, or applicable provisions of local building codes.

Provide make-up air where exhaust fans, clothes dryers, and kitchen ventilation equipment interfere with proper operation.

National Fuel Gas Code recognizes several methods of obtaining adequate ventilation and combustion air. Requirements of the authority having jurisdiction may override these methods.

- Engineered Installations. Must be approved by authority having jurisdictions.
- Mechanical Air Supply. Provide minimum of 0.35 cfm per Mbh for all appliances located within space. Additional requirements where exhaust fans installed. Interlock each appliance to mechanical air supply system to prevent main burner operation when mechanical air supply system not operating.
- All Indoor Air. Calculate minimum volume for all appliances in space. Use a different method if minimum volume not available.
  - Standard Method. Cannot be used if known air infiltration rate is less than 0.40 air changes per hour. See Table 3 for space with boiler only. Use equation for multiple appliances.  

$$\text{Volume} \geq 50 \text{ ft}^3 \times \text{Total Input [Mbh]}$$
  - Known Air Infiltration Rate. See Table 3 for space with boiler only. Use equation for multiple appliances. Do not use an air infiltration rate (ACH) greater than 0.60.  

$$\text{Volume} \geq 15 \text{ ft}^3/\text{ACH} \times \text{Total Input [Mbh]}$$
  - Refer to National Fuel Gas Code for opening requirements between connection indoor spaces.

- All Outdoor Air. Provide permanent opening(s) communicating directly or by ducts with outdoors.
  - Two Permanent Opening Method. Provide opening commencing within 12 inches of top and second opening commencing within 12 inches of bottom enclosure.
    - Direct communication with outdoors or communicating through vertical ducts. Provide minimum free area of 1 in<sup>2</sup> per 4 Mbh of total input rating of all appliances in enclosure.
    - Communicating through horizontal ducts. Provide minimum free area of 1 in<sup>2</sup> per 2 Mbh of total input rating of all appliances in enclosure.
  - One Permanent Opening Method. Provide opening commencing within 12 inches of top of enclosure. Provide minimum clearance of 1 inch on sides and back and 6 inches on front of boiler (does not supersede clearance to combustible materials).
  - Combination Indoor and Outdoor Air. Refer to National Fuel Gas Code for additional requirements for louvers, grilles, screens and air ducts.
- Combination Indoor and Outdoor Air. Refer to National Fuel Gas Code for application information.

National Gas and Propane Installation Code Requires providing air supply in accordance with:

- Section 8.2 and 8.3 when combination of appliances has a total input of up to and including 400 Mbh (120 kW).
  - Does not have draft control device.
- Section 8.4 when combination of appliances has total input exceeding 400 Mbh (120 kW).
- Refer to Natural Gas and Propane Installation Code for specific air supply requirements for enclosure or structure where boiler is installed, including air supply openings and ducts.

**Table 2 - Air Infiltration**

Input Mbh	Standard Method	Known Air Infiltration Rate Method (Air Changes Per Hour)					
		0.1	0.2	0.3	0.4	0.5	0.6
42.5	2125	6375	3188	2125	1594	1275	1063
75	3750	11250	5625	3750	2813	2250	1875
112.5	5625	16875	8438	5625	4219	3375	2813
150	7500	22500	11250	7500	5625	4500	3750
187.5	9375	28125	14063	9375	7031	5625	4688
225	11250	33750	16875	11250	8438	6750	5625

**WARNING**

Burn or Scald Hazard. Discharge line shall be installed to relief valve outlet connection to avoid burns, scalding, or water damage due to discharge of steam and/or hot water during operation.

Discharge line shall:

- connect to relief valve outlet and piped down to safe point of disposal. Check local codes for maximum distance from floor or allowable safe point of discharge.
- be of pipe size equal to or greater than that of the relief valve outlet over the entire length of discharge line;
- have no intervening shutoff valve between safety relief valve and discharge to atmosphere (do not plug or place any obstruction in discharge line).
- terminate freely to atmosphere where any discharge will be clearly visible and at no risk of freezing;
- allow complete drainage of the valve and the discharge line;
- be independently supported and securely anchored to avoid applied stress on the relief valve;
- be as short and straight as possible;
- terminate with plain end (not threaded);
- be constructed of material suitable for exposure to temperatures of 375° F; or greater.

Refer to local codes and appropriate ANSI/ASME Boiler and Pressure Vessel Code, Section IV, or Boiler, Pressure Vessel and Pressure Piping Code, CSA B51 for additional installation requirements.

1. Refer to local codes and appropriate ASME Boiler and Pressure Vessel Code for additional installation requirements.
2. Install relief valve on 3/4" pipe nipple in tapped boiler opening.
  - A. Pipe discharge line following guidelines in preceding **Warning**. See Figure 2, Page 7.
  - B. Discharge line pipe size shall be equal or greater than that of relief valve outlet over entire length of discharge line with no intervening shutoff valve between safety relief valve and discharge to atmosphere.
  - C. Discharge line shall terminate with plain end to atmosphere where any discharge will be clearly visible and is at no risk of freezing.
  - D. Discharge line shall be independently supported to avoid applied stress on relief valve.
  - E. Installation shall allow complete drainage of relief valve and discharge line.
3. Install Drain Valve on lower left side of boiler as marked.
4. Install Temperature and Pressure Gauge into 1/4" bushing threaded in tee furnished with supply piping. See Figure 3 & 4.
5. Connect Supply and Return Lines to boiler. See Figures 3 and 4. Connections may require certain additional fittings and parts.

**Figure 2 - Safety Relief Valve Discharge Piping**

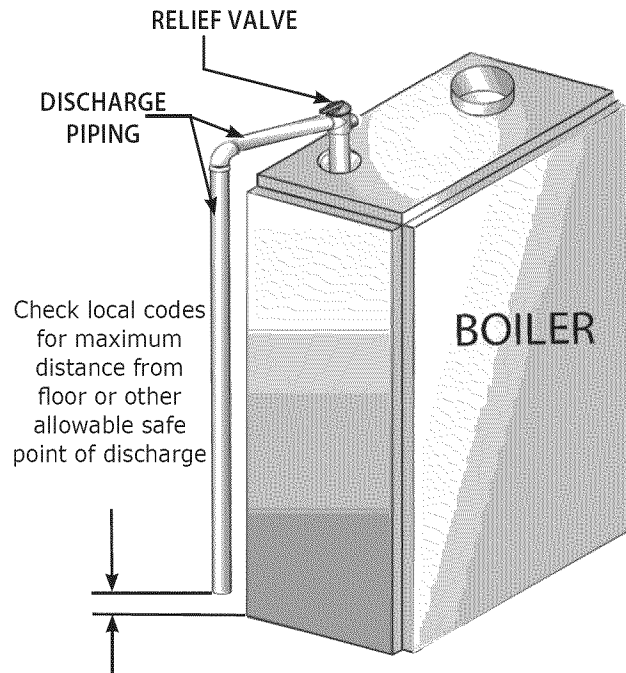

**Figure 3 - Forced Hot Water Typical Piping**

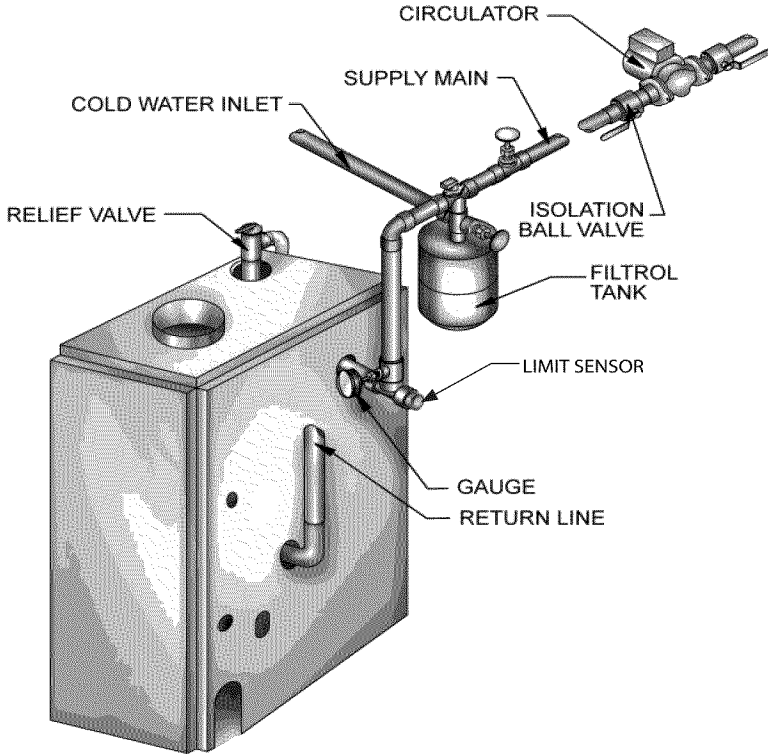

**Figure 4 - Forced Hot Water Typical Piping With Zone Control Valve**

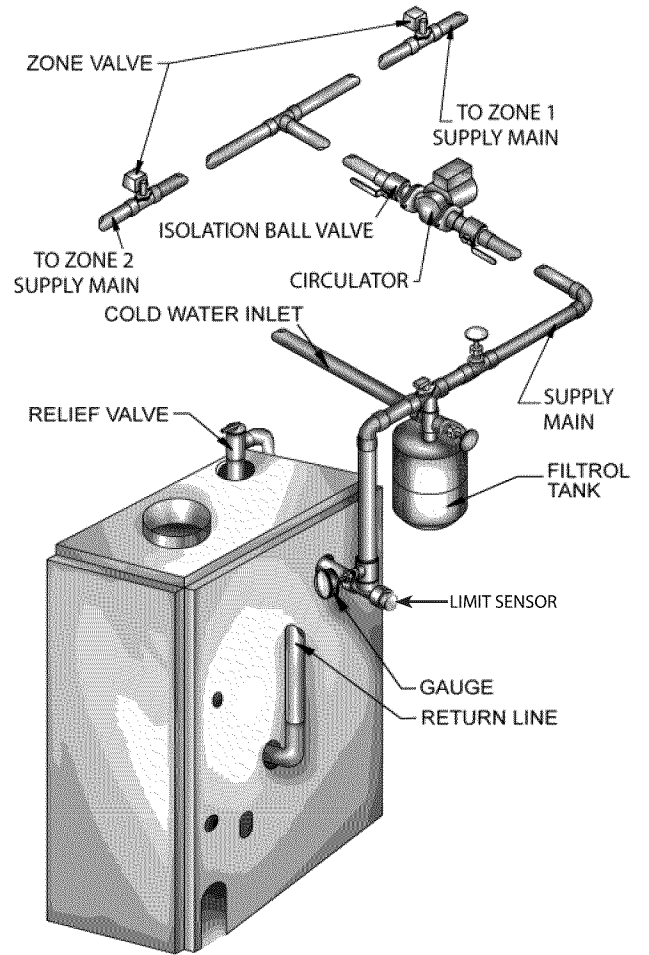

- Install radiation units (panels, radiators or cabinets) and supply and return mains first then make connections at boiler.
- Verify clean water supply is available when connecting cold water supply to water valve. Install sand strainer at pump when water supply is from well or pump.
- Provide low water cutoff device when boiler is installed above radiation level or as required by the Authority having jurisdiction, either provide as part of boiler or at time of boiler installation. Periodic inspection is necessary, as is flushing of float type devices, per manufacturers specific instructions.
- Boiler used in connection with refrigeration systems shall be installed so chilled medium is piped in parallel with heating boiler with appropriate valves to prevent chilled medium from entering heating boiler. See Figure 5.
- Boiler connected to heating coils located in air handling units exposed to refrigerated air circulation, piping system shall be equipped with flow control valves or other automatic means to prevent gravity circulation of boiler water during cooling cycle.

**Low Design Water Temperature Systems (Below 140°F) And Large Water Content Systems**

Condensation is corrosive and can eventually cause severe damage to boiler and venting system.

- Minimum design return water temperature to prevent condensation in boiler and venting is 120°F. Minimum high limit setting is 140°F.
- Boiler used in heating systems where design water temperatures below 140°F are desired (e.g. radiant floor heating), a 3-way or 4-way mixing valve or suitable alternative is required to prevent low temperature return water from entering boiler. When using mixing valve, follow manufacturer’s installation instructions.
- Boiler connected to system having large water content (such as former gravity system), suggest use of bypass piping. See Figure 6.

**Figure 5 - Piping Arrangements For Boiler When Used In Connection With Refrigeration System**

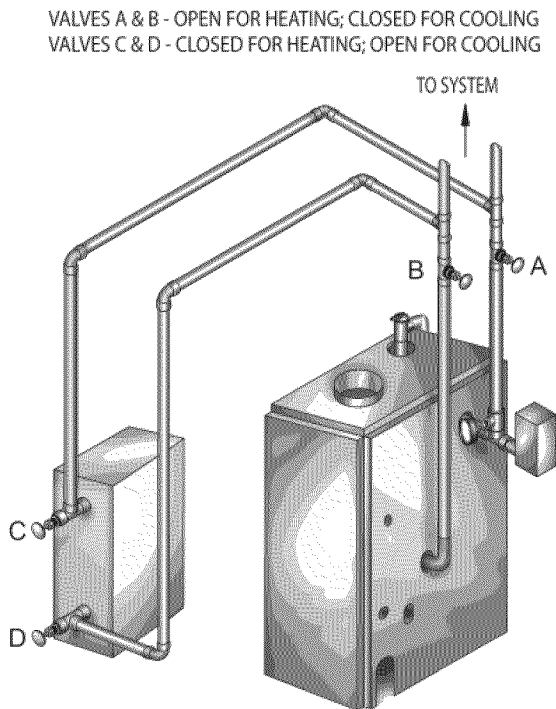

**Figure 6 - Bypass Piping**

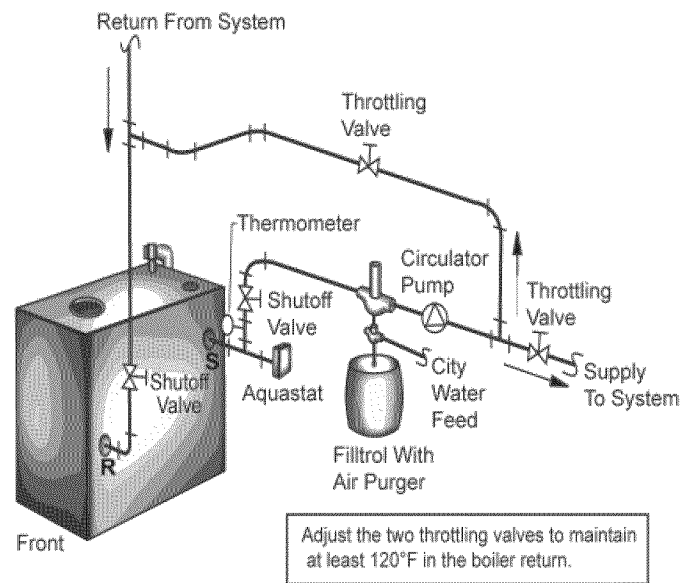

**Check Your Chimney**

Chimney must be clean, right size, properly constructed and in GOOD CONDITION.

1. Installation must conform to requirements of the authority having jurisdiction or, in absence of such requirements, to the National Fuel Gas Code, ANSI Z223.1/NFPA 54.
2. Boiler's induced draft blower has 3" outlet. 3" X 4" increaser fitting is included in parts bag. Locate increaser fitting on outlet of induced draft blower, and secure gas-tight with bead of furnished silicone sealant. Increaser fitting is required on this boiler for Category I venting, and 4" is minimum permissible vent diameter. This does not imply vent connector is intended to be 4" diameter pipe. Vent connector shall be sized according to appropriate venting tables in the National Fuel Gas Code and may be required to be larger than 4" diameter.

**NOTICE**

Boiler installation for chimney venting is not complete unless increaser fitting is located and secured.

3. These are high efficiency boilers with low stack or exhaust temperature.
4. Venting into masonry chimney without liner, line chimney from top to bottom with either:
  - A. Listed Type B vent pipe
  - B. Listed flexible vent liner
  - C. Poured ceramic liner.
5. Outside chimneys should not be used unless they are (choose one of the following):
  - A. Enclosed in a chase
  - B. Lined with Type B vent pipe
  - C. Use listed flexible vent liner
  - D. Use certified chimney lining system
6. Vent connector from boiler to chimney should run as directly as possible with as few elbows as possible.
7. Where possible, it is recommended to common vent water heater and boiler. Consult appropriate Vent Sizing Tables in National Fuel Gas Code for specific requirements of multiple appliance venting.
8. Boiler is only appliance connected to vent, Type B vent pipe is recommended for vent connector.
9. Slope pipe up from boiler to chimney not less than 1/4" per foot (21mm/m).
10. End of vent pipe must be flush with inside face of chimney flue. Use sealed-in thimble for chimney connection.

11. Fasten sections of vent pipe with sheet metal screws to make piping rigid. Use stovepipe wires to support pipe from above.
12. Do not connect to fireplace flue.
13. Do not install damper on this boiler.

**Minimum Vent Pipe Clearance**

- Use Type B vent pipe through crawl space. Where vent pipe passes through combustible wall or partition, use ventilated metal thimble. Thimble should be 4 inches larger in diameter than vent pipe.
- Boiler installed with single wall vent, must have 6" clearance between its surface and any combustible material. New Type B gas vent or flexible liner must be installed in accordance with instructions furnished with vent. Maintain clearances as specified for vent pipe.
- Verify vent pipe is fire-stopped where it goes through floor or ceiling. It should have approved vent cap with clearances from roof. If clearances are less than shown, have vent checked by local authorities. Figure 7, Page 11.
- Vent connectors serving appliances vented by natural draft shall not be connected into any portion of mechanical draft systems operating under positive pressure.

Figure 7 - Type B Gas Vent

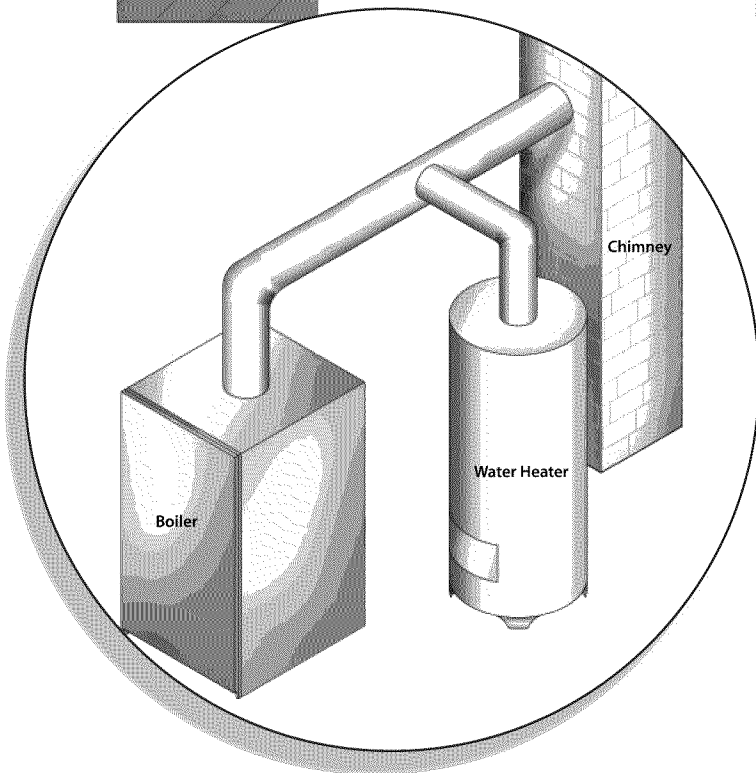
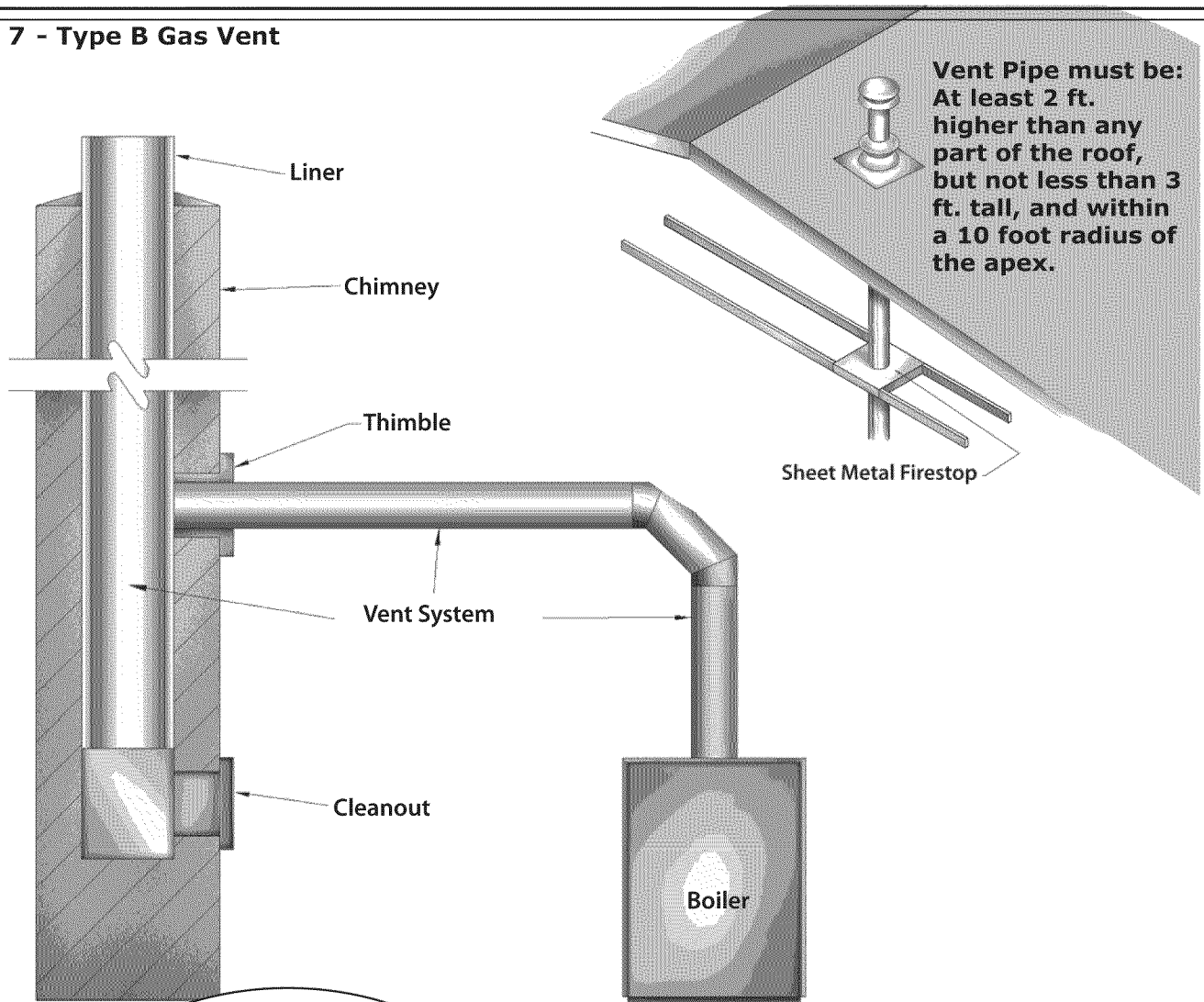

**CHECK YOUR CHIMNEY**

For boilers for connection to gas vents or chimneys, vent installations shall be in accordance with "Venting of Equipment", of the National Fuel Gas Code, ANSI Z223.1/NFPA 54, or applicable provisions of the local building codes.

### Removing Existing Boiler From Common Venting System

When an existing boiler is removed from a common venting system, the common venting system is likely to be too large for proper venting of the appliances remaining connected to it.

At the time of removal of an existing boiler, the following steps shall be followed with each appliance remaining connected to the common venting system placed in operation, while the other appliance remaining connected to the common venting system are not in operation.

1. Seal any unused openings in the common venting system.
2. Visually inspect the venting system for proper size and horizontal pitch and determine there is no blockage or restriction, leakage, corrosion and other deficiencies which could cause an unsafe condition.
3. Insofar as is practical, close all building doors and windows and all doors between the space in which the appliances remaining connected to the common venting system are located and other spaces of the building. Turn on clothes dryers and any appliance not connected to the common venting system. Turn on any exhaust fans, such as range hoods and bathroom exhausts, so they will operate at maximum speed. Do not operate a summer exhaust fan. Close fireplace dampers.
4. Place in operation the appliance being inspected. Follow the lighting instructions. Adjust thermostat so appliance will operate continuously.
5. Test for spillage at the draft hood relief opening after 5 minutes of main burner operation. Use flame of a match or candle, or smoke from a cigarette, cigar, or pipe.
6. After it has been determined that each appliance remaining connected to the common venting system properly vents when tested as outlined above, return doors, windows, exhaust fans, fireplace dampers and any other gas-burning appliance to their previous conditions of use.
7. Any improper operation of the common venting system should be corrected so the installation conforms with the National Fuel Gas Code, ANSI Z223.1/NFPA 54. When re-sizing any portion of the common venting system, the common venting system should be re-sized to approach the minimum size as determined using the appropriate tables in Chapter 13 of the National Fuel Gas Code, ANSI Z223.1/NFPA 54.
8. It is recommended that existing gas vents be checked to be sure they meet local codes.



**INDUCED DRAFT HIGH EFFICIENCY BOILERS**

Horizontal (Category III) venting systems must be installed in accordance with these instructions.

Maximum Horizontal Vent Length For Stainless Steel Vent Pipe - 30' Plus One 90° Elbow Plus Vent Terminal.

Minimum Horizontal Vent Length - 2' Plus One 90° Elbow Vent Termination.

Additional elbows are equivalent to 6 feet of straight pipe for 4" diameter 90° elbow or 3 feet of straight pipe for 3" diameter 90° elbow. 2, 3, 4, 5, Section Boilers use 3" vent pipe; for 6, 7 Section Boilers use 4" vent pipe.

**CHOICE OF VENT PIPE MATERIAL**

- U. L. Listed Z-Flex Z-Vent Stainless Steel Vent Pipe.
- U. L. Listed Heat-Fab Saf-T-Vent Stainless Steel Vent Pipe.
- U. L. Listed Flex-L Star-34 Stainless Steel Vent Pipe.
- U. L. Listed ProTech Systems FasNSeal Stainless Steel Vent Pipe.

**Figure 8 - Induced Draft High Efficiency Boilers**

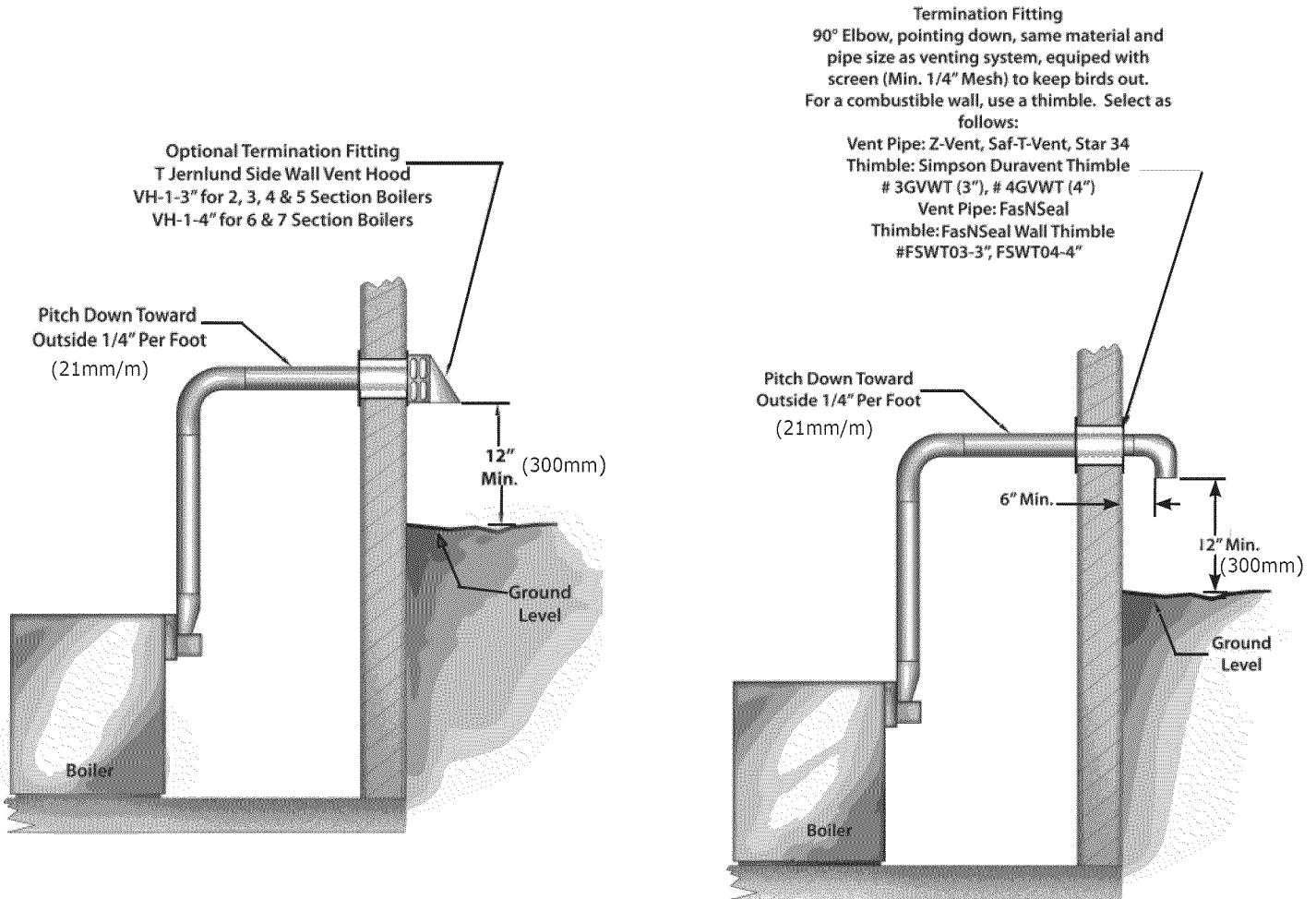

## HORIZONTAL VENTING INSTRUCTIONS

1. Boilers may be vented horizontally as shown in Figure 8, Page 13. Vent pipe is pitched **down** from boiler to vent termination. Do not connect other appliances to this vent.
2. Vent Pipe Material:
  - A. UL Listed Z-Flex Z-Vent stainless steel vent pipe from boiler to vent termination,  
-or-
  - B. UL Listed Heat-FabSaf-T-Vent stainless steel vent pipe from boiler to vent termination,  
-or-
  - C. UL Listed Flex-L StaR-34 stainless steel vent pipe from boiler to vent termination,  
-or-
  - D. UL Listed ProTech FasNSeal stainless steel vent pipe from boiler to vent termination.
3. Clearance to Combustible Materials: For stainless steel vent pipe maintain 6" minimum air space clearance to combustible materials.
4. Vent Pipe Size:
  - A. 2, 3, 4 and 5 section boilers use 3" vent pipe connected directly to the outlet of the induced draft blower.
  - B. 6 and 7 section boilers use 4" vent pipe, starting with a 3" to 4" stainless steel vent pipe transition that is connected directly to the outlet of the induced draft blower. Do not use 3" vent pipe on 6 or 7 section boilers.
5. Vent Pipe Length:
  - A. For stainless steel vent pipe, the maximum horizontal vent length is 30 feet plus one 90° elbow plus termination fitting.
  - B. Minimum horizontal vent length for all vent materials is 2 feet plus one 90° elbow plus termination fitting.
  - C. For additional elbows reduce the maximum vent length as shown:
    - 3" - 90° elbow - reduce vent length 3 feet per each 3" elbow
    - 4" - 90° elbow - reduce vent length 6 feet per each 4" elbow
6. Vent Termination Fitting: For all vent pipe materials, you may use either:
  - A. A 90° elbow pointing down, fitted with a minimum 1/4" mesh screen to keep out rodents and birds. The elbow shall be of the same material and size as vent pipe. The elbow exit should be at least 6" away from exterior wall as shown in Figure 8.  
-or-
  - B. Tjernlund VH-1 Series side wall vent hood. For 2, 3, 4, 5 section boilers use VH-1-3", For 6, 7 section boilers use VH-1-4".
7. Vent Pipe Termination Location See Figure 9:
  - A. When venting through combustible walls, combustible clearances must be considered. The VH-1 Side wall vent hood provides both the outside vent termination and a double wall pipe for passing through a combustible wall up to 8" thick (VH-1-4") or 9" thick (VH-1-3"). The hole in the wall must be 6 1/4" square for 3" vent pipe and 7 1/2" square for 4" vent pipe, in order to insert the VH-1 side wall vent hood. The VH-1 may also be used in noncombustible walls.
  - B. If the 90° elbow is the termination fitting of choice, then the single wall pipe will be passing through the side wall. For combustible walls, a UL listed thimble shall be used where the single wall pipe passes through the wall. For combustible walls using Z-Vent, Saf-T-Vent, or StaR-34 vent pipe, use the following:
    - 3" vent pipe - use Simpson's Duravent 3" thimble
    - 4" vent pipe - use Simpson's Duravent 4" thimble. Maximum wall thickness with this thimble is 7 inches.

For combustible walls using ProTech FasNSeal where the single wall vent pipe must pass through the side wall, a UL Listed FasNSeal wall thimble shall be used.

The thimble is adjustable for different wall thickness, with a maximum wall thickness of 7 inches. Seal the thimble along the outside edge of the plate with caulk or silicone and fasten to the wall with screws or nails.

- C. For single wall pipe through non-combustible walls, the hole through the wall need only be large enough to maintain the pitch of the vent pipe, and provide proper sealing. A thimble is not required for single wall pipe passing through noncombustible walls.

**Example:** 6 section boiler has 3 elbows plus the termination fitting. This means 2 additional 4" elbows will be used, at 6 feet per elbow. This is equivalent to 12 feet of pipe ( $2 \times 6 = 12$ ), therefore maximum vent length is now 18 feet ( $30 - 12 = 18$ ).

**Figure 9 - Horizontal Venting Clearances**

Note: If there is a potential for excessive winds, special consideration should be given to locate the vent termination away from the windward side of the building.

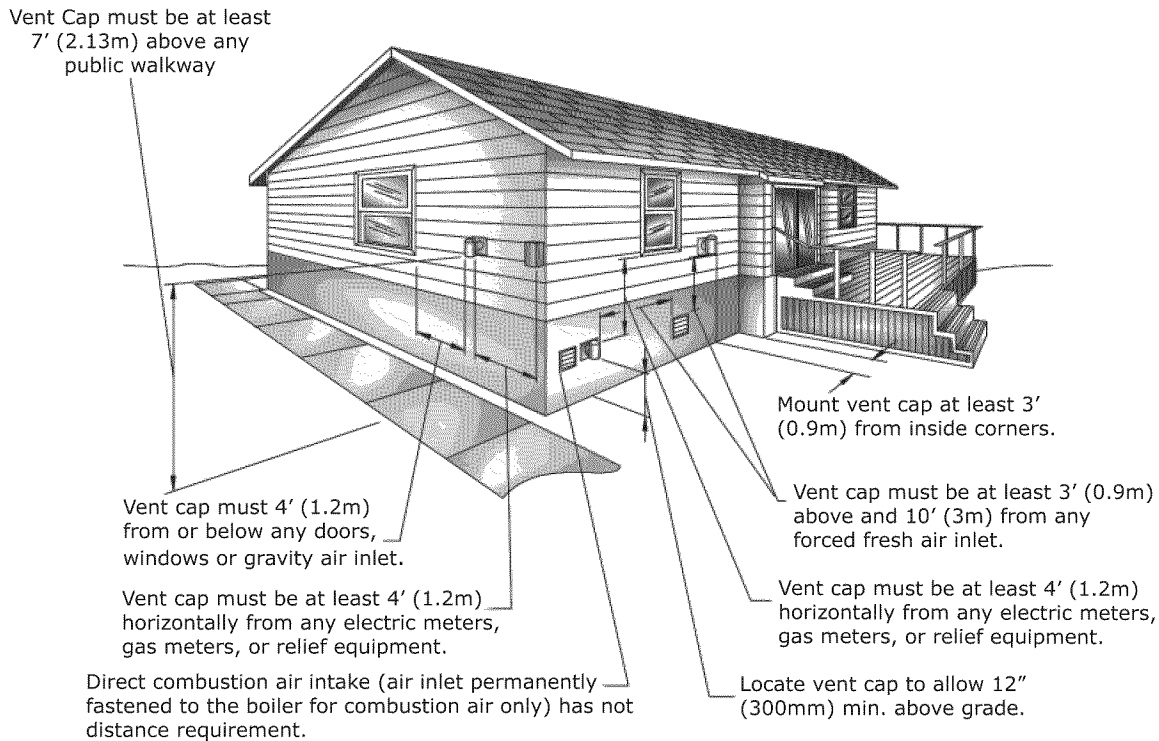

D. The venting system shall terminate at least 3 feet (0.9m) above any forced air inlet located within 10 feet (3m). The venting system shall terminate at least 4 feet (1.2m) below, 4 feet (1.2m) horizontally from, or 1 foot (300 mm) above any door, window, or gravity air inlet into any building. The bottom of the vent shall be located at least 12 inches (300mm) above grade. Termination of the vent shall be not less than 7 feet (2.13m) above adjacent public walkway. The vent terminal shall not be installed closer than 3 feet (0.9m) from the inside corner of an L shaped structure. Termination of the vent should be kept at least 3 feet (0.9m) away from vegetation. The venting system shall terminate at least 4 feet horizontally from, and in no case above or below, unless a 4 foot horizontal distance is maintained, from electric meters, gas meters, regulators, and relief equipment. See **Figure 9**.

**Figure 9.**

**United States** - Terminate vent system at least 4 feet (1.22m) horizontally from, and in no case above or below, unless a 4 feet (1.22m) horizontal distance is maintained, from electric meters, gas meters, regulators and relief equipment.

- A. The venting system shall terminate at least 4 feet below any eave, soffit, or roof overhang.
- B. The venting system shall not terminate underneath any deck, patio, or similar structure.
- C. Put vent on a wall away from the prevailing winter wind. Locate or guard the vent to prevent accidental contact with people or pets.
- D. Terminate the vent above normal snow-line. Avoid locations where snow may drift and block the vent. Ice or snow may cause the boiler to shut down if the vent becomes obstructed.
- E. Under certain conditions, flue gas will condense, forming moisture. In such cases, steps should be taken to prevent building materials at the vent terminal from being damaged by exhaust of flue gas.

**8. Joining and Sealing the Vent Pipe:**

The vent pipe needs to be both watertight and gas tight. Seal all joints and seams as follows:

A. For Z-Flex Z-Vent stainless steel vent pipe use a high temperature silicone sealant rated for 550°F. The outside of the male end and inside of the female end of the pipe must be cleaned with brake cleaner before applying silicone bead. For 3" vent pipe runs begin with the male end of the vent pipe over the boiler's induced draft blower outlet. For 4" vent pipe runs begin with a 6" length of 3" Z-Vent over the boiler's induced draft blower outlet, to which an even bead of high temperature silicone sealant should be applied. Then connect the 3" Z-Vent to a Z-Vent 3" to 4" reducer. Then continue the 4" Z-Vent pipe run by connecting the 4" male end of the Z-Vent to the reducer. (A locking band may be used around this joint for additional support.) Then following the sealing instructions, push the 4" male end of the Z-Vent over the 4" increaser fitting. When using the Tjernlund VH-1 vent hood, the female end (flared end) of the vent pipe will be connected to the termination hood. The male end of the vent hood must be crimped before pushing the Z-Vent over the vent hood's connecting pipe. Before the pipes are joined, apply a 1/4" bead of silicone one inch from the end of the male end. Then push the pipes together as far as they will go making sure any seams are aligned and oriented upward. Now apply another bead of silicone around this joint and smooth out. Then use a Z-Flex locking band around the center of the joint.

1. Apply the high temperature silicone approximately one inch from the end, around the male end of the pipe in an even 1/4" bead.
2. Pipes can now be pushed together as far as they will go. The seams on pipe should be aligned and oriented upward in all horizontal appliances. Apply another bead of silicone around this joint and smooth out.
3. Slide locking band over center of joint and tighten gear clamps. Make sure locking band is centered on joint.
4. Check all joints and seams for gas tightness.
5. Horizontal venting shall have slope not less than 1/4" every 12 inches (21mm/m) downward away from the boiler to prevent collection of condensate throughout the assembly.
6. Allow sealant to cure for 24 hours before operating appliance.

B. For Heat-Fab Saf-T-Vent stainless steel vent pipe use a high temperature silicone sealant rated for 550°F The outside of the male end and inside of the female end of the pipe must be cleaned before applying the silicone bead. For 3" vent pipe runs, the male end of the vent pipe which goes over the outlet of the boiler's induced draft blower must be crimped. The vent pipe should be crimped as minimal as possible to provide a tight fit over the outlet. After crimping is completed follow the instructions for applying silicone sealant. For 4" vent pipe runs, begin with a Saf-T-Vent 3" to 4" increaser fitting over the boiler's induced draft blower outlet, to which an even bead of high temperature silicone sealant should be applied. Then continue the 4" Saf-T-Vent pipe run by connecting the 4" male end of the Saf-T-Vent to the increaser. (A locking band may be used around this joint for additional support.) The vent flow must be in the direction indicated on the vent pipe. When using the Tjernlund VH-1 vent hood, the female end (flared end) of the vent pipe will be connected to the termination hood. Apply high temperature silicone in an even 1/4" bead approximately 1/4" to 3/8" from the end of the vent hood's connecting vent pipe. Also, run a similar size bead of silicone sealant down the seam weld of the vent pipe. Then push the female end over the vent hood's connecting vent pipe.

1. Apply the high temperature silicone around the male end of the pipe (without the tabs) in an even 1/4" bead. Silicone bead should be approximately 1/4" to 3/8" from the end of the male end. Also, run a similar size bead of silicone sealant down the seam weld at the end of each joint.
2. Pipes can now be pushed together as far as they will go. The seams on the vent pipe should be aligned and oriented upward in all horizontal appliances. With a moistened finger or flat tool, spread any sealant that squeezes out around the circumference of the joint.
3. Attach the sections together with the locking rings and tabs (except at the blower outlet where no locking ring exists.) Inspect the joint to ensure that flue gases will not leak. If necessary apply additional sealant around the joint.
4. Horizontal venting shall have a slope not less than 1/4" every 12 inches (21mm/m) downward away from the boiler to prevent collection of condensate throughout the assembly.
5. Allow the sealant to cure for 24 hours before operating the appliance.

- C. For Flex-L StaR-34 stainless steel vent pipe use a high temperature silicone sealant rated for 550°F. Before applying silicone, the outside of the male end and inside of the female end of the pipe must be cleaned using a cleaner, such as methyl ethyl ketone (MEK) or naphtha. For 3" vent pipe runs, begin with the male end of the vent pipe over the boiler's induced draft blower outlet. For 4" vent pipe runs begin with a StaR-34 3" to 4" increaser fitting over the boiler's induced draft blower outlet. For both 3" and 4" vent pipe runs, apply a bead of silicone sealant around the blower outlet and around the inside of the male end of vent pipe going over the blower's outlet. When using the Tjernlund VH-1 vent hood, the female end (flared end) of the vent pipe will be connected to the termination hood. Apply high temperature silicone in an even ¼" bead approximately ¼" from the end of the vent hood's connecting vent pipe. Also, run a similar size bead of silicone sealant down the seam weld of the vent pipe. Then push the female end over the vent hood's connecting vent pipe. Now fill in the channel inlet with silicone sealant. Do not try to insert the joiner band, instead fasten the vent pipe to the vent hood's pipe with a steel gear clamp.
1. Apply the high temperature silicone around the male end of the pipe in an even ¼" bead. Silicone bead should be approximately ¼" from the end of the male end. Also, run a similar size bead of silicone sealant down the seam weld at the end of each joint.
  2. The seams on the vent pipe should be aligned and oriented upward in all horizontal vent pipe runs.
  3. Insert the male end of one into the female end of the other. Push the pipe together so the female end rests up against the stop bead of the male end.
  4. Insert a StaR-Joiner Band into the inlet of the beaded channel. Feed the Joiner Band in so it makes its way around the pipe, back to the channel inlet and it overlaps itself by about ½".
  5. Cut the excess Joiner Band so it lays flat in the beaded channel. Fill the inlet of the beaded channel with high temperature silicone. Smooth out the silicone over the channel inlet and the silicone between the female end and the stop bead of the male end.
  6. Horizontal venting shall have a slope not less than ¼" every 12 inches (21mm/m) downward away from the boiler to prevent collection of condensate throughout the assembly.
  7. Allow the sealant to cure for 24 hours before operating the appliance.

- D. For ProTech Systems FasNSeal stainless steel vent pipe no cleaning fluid is required. For 3" vent pipe runs on 2, 3, 4 and 5 section boilers, begin by locating the FasNSeal Ametek Adapter over the boiler's induced draft blower. Continue the vent pipe run with 3" FasNSeal vent pipe. For 6 and 7 section boilers, begin by locating the FasNSeal Ametek Adapter over the boiler's induced draft blower. Then connect a FasNSeal 3" to 4" increaser to the 3" adapter outlet. Continue the vent pipe run with 4" FasNSeal vent pipe. Other than the Ametek Adapter and increaser fitting, DO NOT use 3" vent pipe on 6 or 7 section boilers. FasNSeal vent pipe is joined and sealed by the use of an internal sealing gasket and a locking band on the female end of each vent pipe. All components should be examined for possible shipping damage prior to installation. Align all vent pipe seams and orient upward in all horizontal applications. Adjustable vent lengths are available for 4" diameter vent piping. For 3" diameter vent piping, square cut male end at the desired length. For 2, 3, 4 and 5 section boilers using the VH-1-3" vent hood, connect the FasNSeal Vent to the VH-1-3" vent hood using FasNSeal Adapter #FSC-DUN-3. This adapter has no internal sealing gasket. To attach the adapter to the vent hood, crimp the 3" vent hood pipe, apply a ¼" bead of high temperature silicone sealant around the outside of the vent hood's crimped connecting pipe and a similar bead of high temperature silicone around the inside of the FasNSeal adapter. After pressing the two pipes together and tightening the locking band, finish creating a complete seal by filling the FasNSeal adapter's notched hole with high temperature silicone. For 6 and 7 section boilers using the VH-1 - 4" vent hood, an adapter is not required. The 4" FasNSeal vent pipe connects directly to the VH-1- 4" vent hood, and is joined and sealed by the internal gasket and locking band.

To join and seal the FasNSeal vent pipe:

1. Insert male end into female section.
2. Push the units together as far as possible.
3. Firmly tighten locking band with a nut driver.
4. DO NOT penetrate the FasNSeal vent pipe with fasteners.
5. Horizontal venting shall have a slope of not less than ¼" every 12 inches (21mm/m) downward away from the boiler to prevent the collection of condensate throughout the assembly.

## HORIZONTAL VENTING INSTRUCTIONS

### 9. Support Spacing:

Do not restrict thermal expansion movement of the vent. The vent pipe must expand and contract freely with temperature change. Each run of vent piping shall be supported as follows:

- A. Z-Flex stainless steel vent piping requires a loose fitting metal strap or similar support at each joint at a maximum of 4 feet between supports.
- B. Heat-Fab stainless steel vent piping requires a support for every 6 feet of horizontal piping run. The support must be secured using at least #10 fasteners to a solid material (solid masonry or wood framing or blocking.) Do not fasten to drywall sheathing using hollow wall anchors. Each support will be 1½ inch lower than the previous support when spaced 6 feet apart.
- C. Flex-L stainless steel vent piping requires a loose fitting metal strap or similar support at each joint at a maximum of 4 feet between supports.
- D. ProTech stainless steel vent piping requires one loose fitting FasNSeal support strap for every 6' of horizontal vent.

10. If the horizontal vent must go through a crawl space or other unheated space, the cool temperatures will likely cause the flue gases to continuously condense inside the vent pipe. Do not insulate the vent pipe. It must be visible for monthly inspection. Insure that the vent pipe is properly pitched away from the boiler, with no low spots, so that condensate in the vent will drain away from the boiler. An insulated enclosure or chase, with access for inspection and servicing of the vent, may be required to prevent freezing of liquid condensate. Consult the vent pipe manufacturer's instructions for specific guidelines.

11. At beginning of each heating season and monthly during the heating season, check all vent pipes and vent terminal to make sure there are no obstructions. Periodically clean the screen in the vent terminal.

## OPTIONAL HORIZONTAL VENTING INSTRUCTION

Horizontal venting with a power venter is an alternate method of sidewall venting. This boiler is CSA listed for sidewall venting with standard single wall galvanized or Type B vent pipe when using the following power venter kits, which were specifically sized for these boilers:

<b>Table 3 - Field Controls</b>	
<b>Number Of Boiler Sections</b>	<b>Field Controls Power Venter</b>
2, 3, 4, 5	SWG-4D
6, 7	SWG-5D

Some possible reasons for using a power venter for sidewall venting:

- 1. May be preferred by local codes.
- 2. Need a vent piping run beyond 30' (9.1m) (but not more than 50' (15.2m)).
- 3. The boiler installation site experiences gusting or high winds. A power venter can help prevent the boiler from short cycling due to gusting or high winds by providing vent exhaust pressures greater than the boiler's induced draft blower alone.
- 4. When installers or homeowners prefer a negative pressure vent system instead of a positive pressure vent system.
- 5. May be more cost effective than stainless steel venting, particularly at longer vent length. The Field Controls power vent kit includes either a SWG-II-4HD or SWG-II-5 power venter, a MG-1 4" barometric draft controller, and the CK-43D controls kit.

Confirm that installing a power venter is an option allowed by local codes. Follow the specific power venter installation instructions issued with the power venter kits. Although the power venter is equipped with its own fan, the fan on the boiler remains in place and is unaltered when a power venter is used.

When sidewall venting, flue gases must be vented to a point in relation to the prevailing wind so that they may freely disperse without being blown back at the building causing discoloration, or into the building through doors or windows causing odors. Also, under certain conditions flue gases will condense, forming moisture. In such cases, steps should be taken to prevent building materials at the vent terminal from being damaged by the exhausted flue gas.

When installing single wall galvanized vent pipe for power venting follow the specific power venter installation instructions for layout, location of the barometric draft control and termination connections.

When joining and sealing the single wall galvanized or Type B vent piping, use RTV silicone sealant with a minimum temperature rating of 400°F. For 3" vent pipe runs, begin with the female end of the vent pipe over the boiler's induced draft blower outlet. For 4" vent pipe runs begin with the galvanized 3" to 4" increaser fitting (included in the boiler's parts bag) over the induced draft blower outlet. Then follow by placing the female end of the 4" vent pipe over the increaser fitting.

When joining pieces of single wall galvanized vent pipe, a substantial bead of silicone should be used at the joint to insure a leak proof connection.

**CAUTION**

**WHAT TO DO IF YOU SMELL GAS**

- Do not try to light any appliance.
- Do not touch any electrical switch; do not use any phone in your building.
- Immediately call your gas supplier from a neighbor's phone. Follow gas supplier's instructions.
- If you cannot reach your gas supplier, call the fire department.

**Figure 10 - Gas Piping At Boiler**

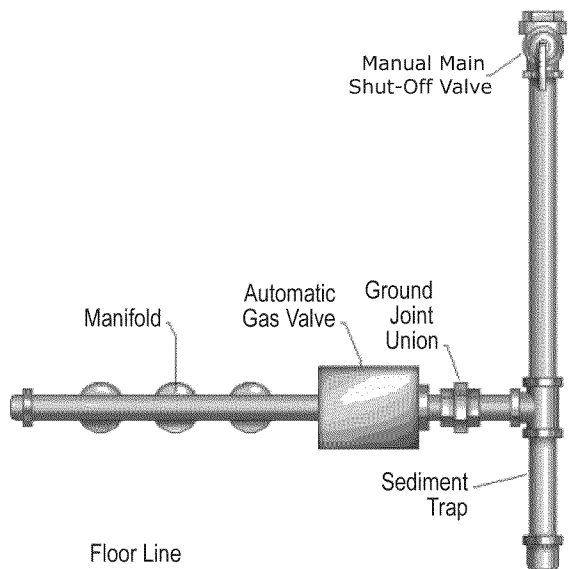

**Connecting Gas Piping**

Gas line enters boiler from right side. Flexible gas connectors must never breach any boiler openings.

- Use piping materials and joining methods acceptable to authority having jurisdiction. In absence of such requirements National Fuel gas Code, ANSI Z223.1/ NFPA 54
- All pipe compound must be resistant to liquefied petroleum gas.
- Install ground joint union in gas supply line between shut-off valve and boiler controls.
- Install sediment trap upstream of gas controls.
- Use two pipe wrenches when making connection to gas valve to keep it from turning.
- Install manual shut-off valve in vertical pipe about 5 feet (1.5m) above floor. See Figure 10.
- Tighten all joints securely.
- Propane gas connections should only be made by licensed propane installer.
- Two-stage regulation should be used by propane installer.
- Propane gas piping should be check by propane installer.

**Check Gas Supply**

Gas pipe must be correct size for length of run and for total BTU per hour input of all gas utilization equipment connected to it. See Gas Table 6 & 7, Page 20 for proper size. Be sure your gas line complies with local codes and gas company requirements.

**DANGER**

Fire Hazard. Do not use matches, candles, open flames, or other methods providing ignition source. Failure to comply will result in death or serious injury.

**Table 4 - Supply Piping Size**

PRESSURE	GAS	
	NATURAL	PROPANE
MIN. SUPPLY	5" w.c.	11" w.c.
MAX. SUPPLY	13.5" w.c.	13.5" w.c.
MANIFOLD	3.5" w.c.	10" w.c.

Verify minimum pressure while boiler is operating.  
Verify maximum prssure when boiler is not operating

**Check Gas Piping**

Pressure test boiler and gas connection before placing boiler in operation.

- Pressure test over 1/2 psig (3.5 kPa). Disconnect boiler and its individual gas shutoff valve from gas supply system.
- Pressure test at 1/2 psig (3.5 kPa) or less. Isolate boiler from gas supply system by closing manual gas shutoff valve. See Figure 5 & 6, Page 9.
- Locate leakage using gas detector, noncorrosive detection fluid, or other leak detection method acceptable to authority having jurisdiction.
- Correct leaks immediately and retest.

## GAS SUPPLY PIPING

**Table 5 - NATURAL GAS**

Length of Pipe - Ft.	Pipe Capacity - BTU Per Hour Input Includes Fittings			
	1/2"	3/4"	1"	1 1/4"
20	92,000	190,000	350,000	625,000
40	63,000	130,000	245,000	445,000
60	50,000	105,000	195,000	365,000

**Table 6 - PROPANE GAS**

Length of Pipe - Ft.	Pipe Capacity - BTU Per Hour Input Includes Fittings			
	Copper Tubing*		Iron Pipe	
	5/8"	3/4"	1/2"	3/4"
20	131,000	216,000	189,000	393,000
40	90,000	145,000	129,000	267,000
60	72,000	121,000	103,000	217,000

**\*Outside diameter:**

Measure length of pipe or tubing from gas meter or propane second stage regulator.



**WARNING**

Electrical shock hazard. Turn OFF electrical power supply at service panel before making electrical connections. Failure to do so could result in death or serious injury.

**Electrical Wiring**

See wiring diagram Figure 12, Page 23 for details. Refer to Ladder Diagram from document envelope received with boiler.

Electrically bond boiler to ground in accordance with requirements of authority having jurisdiction. Refer to National Electrical Code, ANSI/NFPA 70.

If any of the original wire as supplied with this appliance must be replaced, it must be replaced with type 105°C thermoplastic wire or its equivalent

Circulator harness is factory wired to control module. Connect harness to circulator in field. See Figure 11.

**Electric Power Supply**

Run a separate 115 volt circuit from separate over current protective device 15 ampere circuit in electrical service entrance panel.

Connect 115 volt power supply to terminals L1 (HOT) and L2 inside J box.

Run 14 gauge or heavier copper wire from boiler to grounded connection in service panel or properly driven and electrically grounded ground rod.

**Thermostat Installation**

1. Thermostat should be installed on an inside wall about four feet above the floor.
2. NEVER install a thermostat on an outside wall.
3. Do not install a thermostat where it will be affected by drafts, hot or cold pipes, sunlight, lighting fixtures, televisions, a fireplace, or a chimney.
4. Check thermostat operation by raising and lowering thermostat setting as required to start and stop the burners.
5. Instructions for the final adjustment of the thermostat are packaged with the thermostat (adjusting heating anticipator, calibration, etc.)
6. Set heat anticipator at .2 amps. 24 volt thermostat connects to yellow low voltage wires labled T.

**Figure 11 - Control Module Panel**

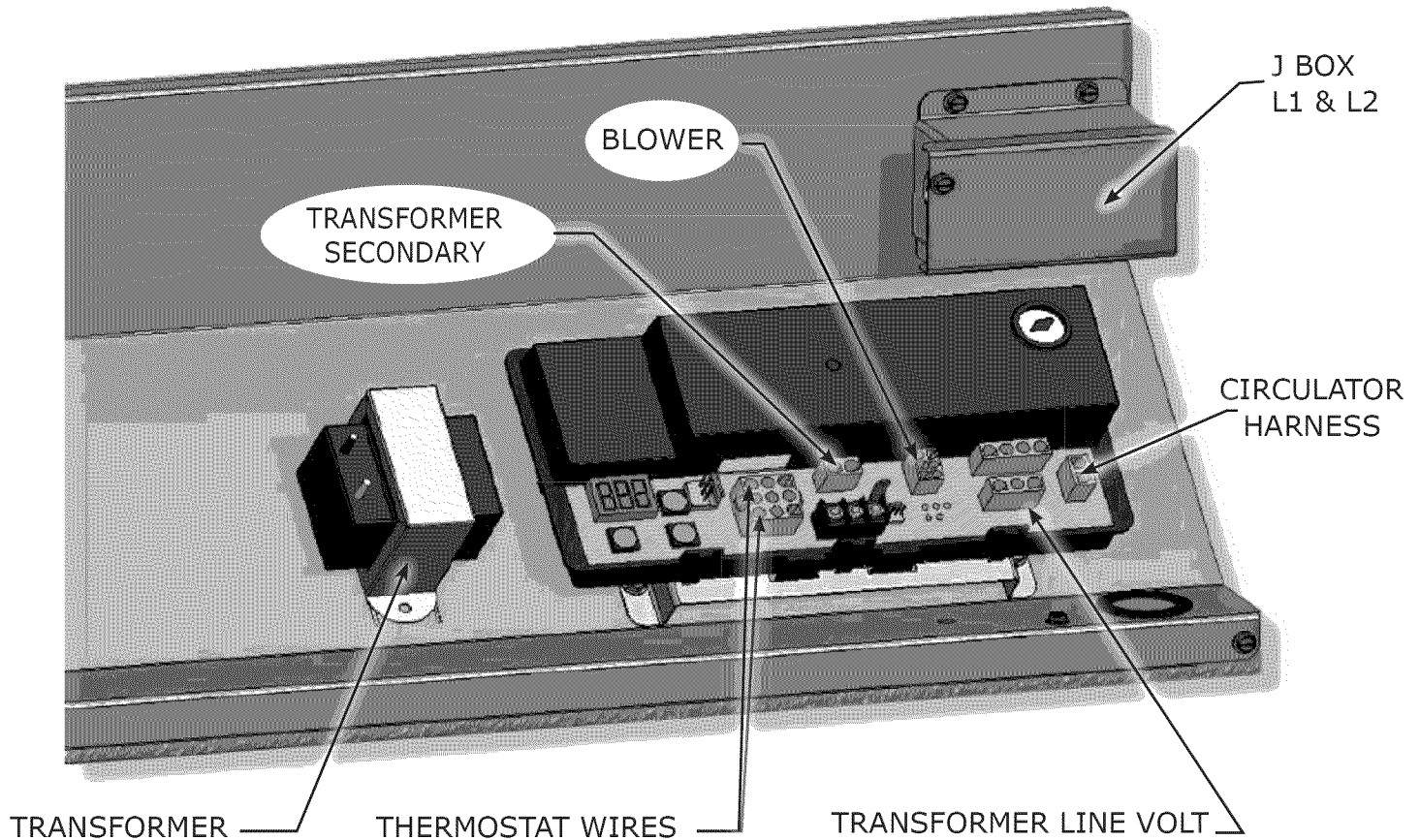

**Sequence of Operation -See Figure 12, Page 23**

1. Thermostat calls for heat, control relay contacts.
2. Circulator pump is powered through terminals C1 and C2. Control holds off burner and attempts to satisfy thermostat with residual boiler heat.
3. Induced draft blower and transformer primary are powered.
4. When blower gets up to speed and blower suction pressure reaches pressure switch set point, pressure switch contacts close sending 24 volts to pilot control from transformer secondary.
5. Pilot gas valve opens and spark initiates to light pilot burner.
6. When pilot flame is proven, spark drops out.
7. Main gas valve opens and pilot burner ignites main burners.
8. If boiler water temperature reaches high limit set point, high limit contacts open, cutting power to blower and pilot control. Burners extinguish and blower stops. Circulator pump continues to run as long as the thermostat continues to call for heat. When boiler water temperature drops past the high limit set point and through the differential, high limit contacts close, repeating steps 3-7.
9. If venting system becomes blocked, blower suction pressure will drop below pressure switch set point, opening pressure switch contacts and cutting power to pilot control. Burners will extinguish, but blower will remain powered as long as thermostat continues to call for heat. If venting system clears, steps 4-7 will repeat.
10. Thermostat is satisfied, ending call for heat. Relay coil is de-energized, opening contacts. Burners extinguish. Blower and circulator pump stop.

Figure 12 - Control Module

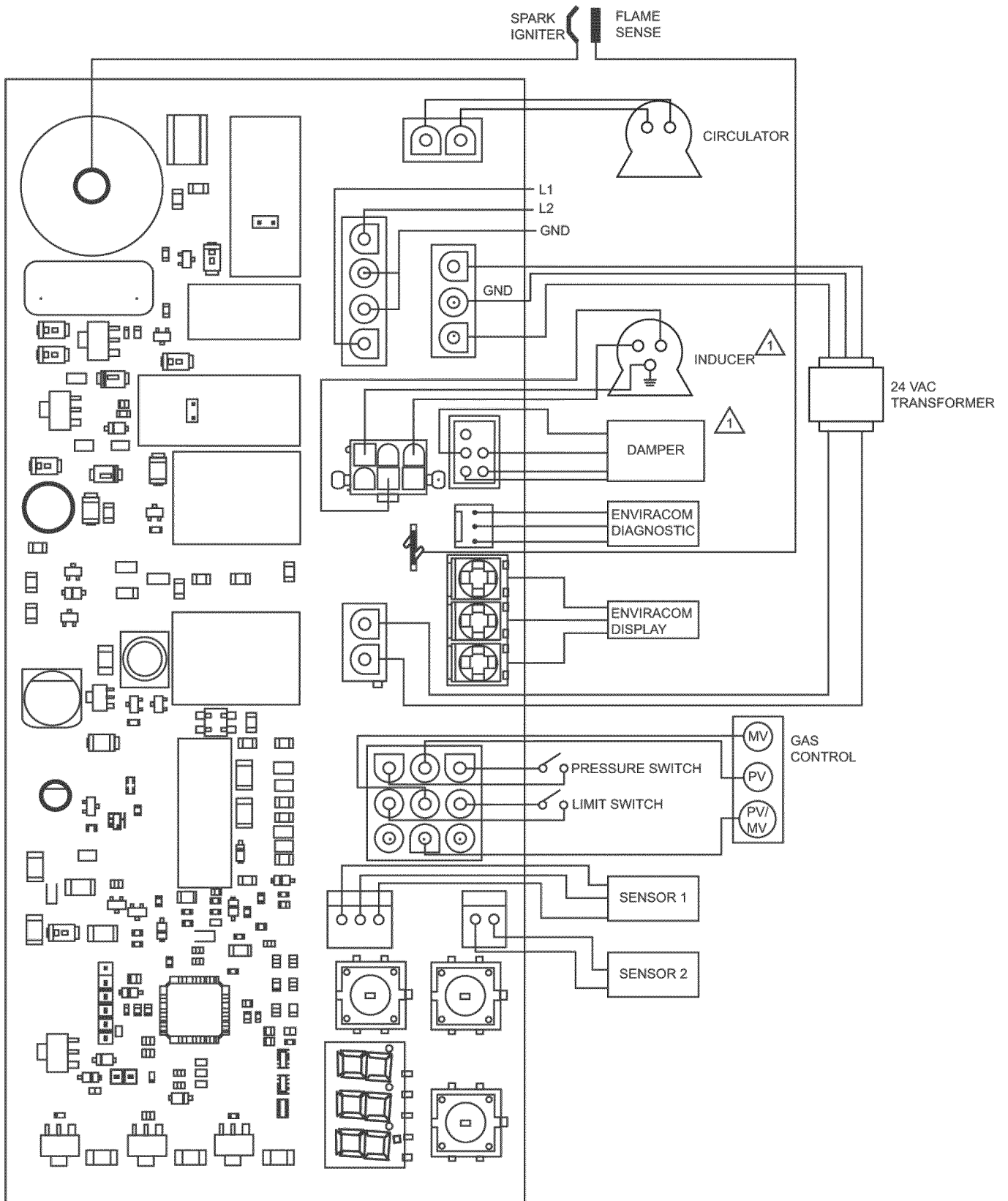

△ OPTIONAL DEPENDING ON CONFIGURATION  
 Damper is not an option.

**NOTICE**

Do not add water into hot empty boiler.

**Filling System With Water**

- Close air vents on all radiation units. Open valves to these units.
- Verify boiler and expansion tank drain valves are closed. Air bleed screw on tank drain fitting should be closed.
- Open valve in line from boiler to expansion tank.
- Open water inlet to your boiler and leave open.
- Start with lowest radiation unit. Open air vent on this unit. When all air has escaped and water starts to flow from vent, close it.
- Go to next radiation unit, and repeat this process.
- Repeat until you have covered every radiation unit in system. End at highest unit in system.
- If units have automatic vents, manual venting is unnecessary but it will speed up proper filling of system.
- If system is closed expansion tank system, you may have automatic fill valve. Leave it open to refill system automatically as needed.
- Check temperature-pressure gauge. Note position of hand indicating pressure. This should be between 10 and 15 psi. Any lowering of this movable hand below 10 psi indicates loss of water due to leakage. Automatic fill valve should compensate for this. Instructions are packaged with valve.

**WARNING**

**If you do not follow these instructions exactly, a fire or explosion may result causing property damage, personal injury or loss of life.**

- This appliance is equipped with an ignition device which automatically lights burner. **Do NOT try to light this burner by hand.**
- Before operating smell all around appliance area for gas. Be sure to smell next to floor because some gas is heavier than air and will settle to the floor.
- **Use only your hand to turn the gas shutoff valve.** Never use tools. If valve will not turn by hand, do not try to repair it, call a qualified service technician. Force or attempted repair may result in fire or explosion.
- **Do not use this appliance if any part has been under water.** Immediately call a qualified service technician to inspect appliance and to replace any part of control system and any gas control which has been under water.

**LIGHTING PROCEDURE FOR BOILER WITH INTERMITTENT PILOT SYSTEM**

**For Your Safety, Read Before Operating!!**

- A. This appliance is equipped with an ignition device which automatically lights the pilot. Do not try to light appliance by hand.

**CAUTION**

**WHAT TO DO IF YOU SMELL GAS**



- Do not try to light any appliance.
- Do not touch any electrical switches; do not use any phone in your building.
- Immediately call your gas supplier from a neighbor's phone. Follow the gas supplier's instructions.
- If you cannot reach your gas supplier, call the fire department.

**Operating Instructions.**

1. **STOP! Read Safety Information on previous page.**
2. Set the thermostat to lowest setting.
3. Turn off all electric power to the appliance.
4. This appliance is equipped with an ignition device which automatically lights the burner. Do not attempt to light pilot by hand.
5. Remove burner access panel.

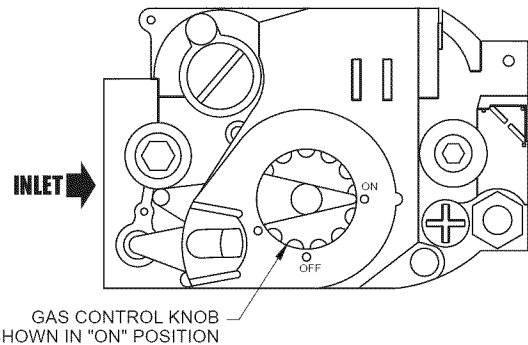
**Figure 13 - Gas Control Knob**



6. Depress gas control knob slightly and turn clockwise  to "OFF" position.
7. Wait five (5) minutes to clear out any gas. If you then smell gas STOP! Follow WHAT TO DO IF YOU SMELL GAS. If you don't smell gas, go to next step.
8. Turn gas control knob counterclockwise  to "ON."
9. Turn on all electric power to the appliance.
10. Set thermostat to desired setting.
11. After visually inspecting the flame, replace lower front panel.
12. If appliance will not operate after several tries, turn gas control knob to "OFF" and call your service technician or gas supplier.

**To Turn Off Gas To The Appliance**

1. Set the thermostat to lowest setting.
2. Turn off all electric power to the appliance if servicing is to be performed.
3. Depress gas control knob slightly and turn clockwise  to "OFF" position. Do not force.

**Gas Valve Safety Shutdown Test****⚠ WARNING**

Electrical shock hazard. Follow instructions to turn off electric power. Failure to do so could result in death or serious injury.

Ignition system safety shutoff device must be tested after placing boiler in operation.

With main burners firing, disconnect ignition cable from intermittent pilot control box. Gas valve should shut off main burners. **TURN OFF ELECTRIC POWER** to boiler before reconnecting ignition cable, to prevent electric shock.

**Adjust Pilot Burner**

1. Remove screw cover over pilot adjusting screw.
2. Insert small screwdriver and adjust flame as needed. See Figure 14 & 15. Turn screw counterclockwise to increase flame, clockwise to decrease. Replace screw cover over pilot adjusting screw.

**Main Burner(S)**

Main burners do not require primary air adjustment and are not equipped with primary air shutters.

Main burner flames form sharp blue inner cones in softer blue outer mantel, with no yellow. Puffs of air from blowing on flame or stamping on floor will cause flames to turn orange momentarily. *This is not unusual.* Remain still when observing main burner flames. See Figure 16, Page 27. If flame appearance is not correct, check main burner orifices, burner throat and flame ports for dust and lint obstruction. It may be necessary to remove rollout shield to observe main burner flames. Replace rollout shield after observation.

**Adjust Limit Controls**

Instructions for each control are included with the controls.

**Recommended Boiler Water Temperatures**

Settings can be changed after you have had some idea how the system works. **Example:** *If your system does not give quite enough heat in very cold weather, you can raise limit setting to 190°F.*

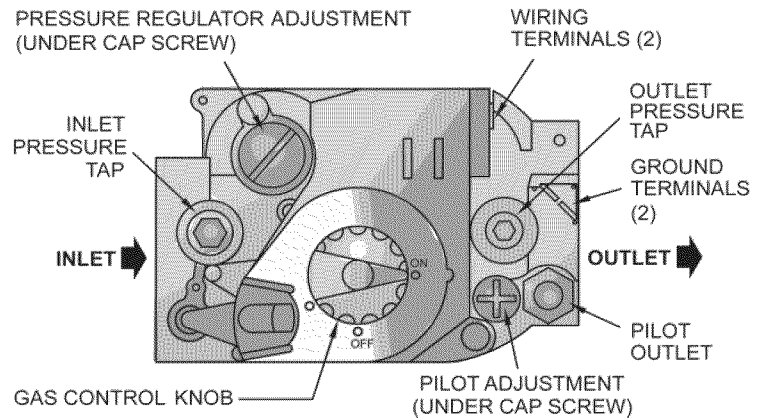
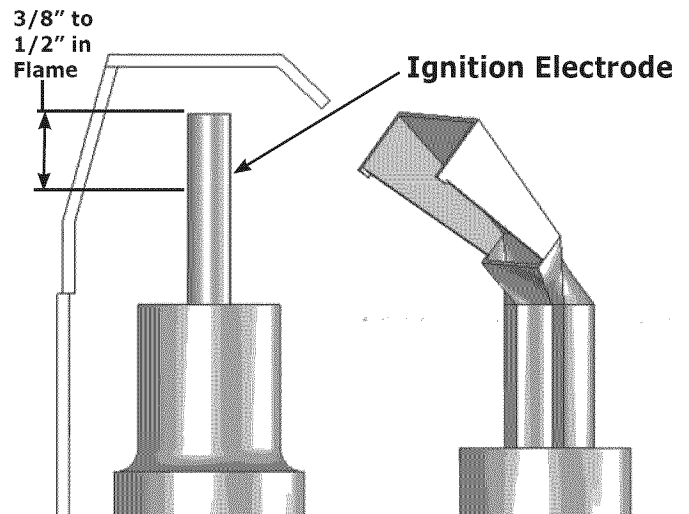
**Figure 14 - Automatic Gas Valve****Figure 15 - Pilot Flame Adjustment**

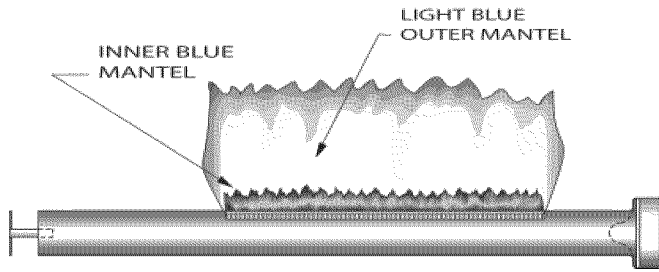
**Figure 16 - Main Burner Flame**

Main burner flame should form sharp blue inner mantel with no yellow.

### Adjust Thermostat Heat Anticipator

Instruction for final adjustment of thermostat are packaged with thermostat.

1. Set Heat anticipator at .2.
2. Check thermostat operation. When set above temperature indicated on thermometer, boiler burners should ignite. Verify thermostat turns off boiler when room temperature reaches selected setting and starts boiler operating when room temperature falls few degrees. After setting limit control to desired setting, check to see if it shuts off gas supply to burners.
3. Turn your thermostat up to call for heat and let your boiler run until temperature of water reaches limit setting. Gas valve shuts off and circulator keeps running until thermostat is satisfied, or water cools enough to restart burners through limit control.
4. To check operation of contacts in pressure switch, disconnect rubber tubing (located between blower and pressure switch) from pressure switch, while boiler is operating. Burners extinguish and blower keeps running. When tubing is reconnected to pressure switch, ignition sequence begins, resulting in ignition of main burners.
5. Set thermostat for desired temperature.

Safe lighting and other performance criteria were met with gas manifold and control assembly provided on boiler when boiler underwent tests specified in ANSI Z21.13.

**Burners**

Beginning of heating season visually check pilot end main burner flames. See Figures 14, 15 & 16 Pages 26 & 27.

**Safety Relief Valve**

Test safety relief valve for proper operation. Refer to valve manufacturer’s instructions packaged with relief valve.

**Expansion Tank (Non-diaphragm)**

Tank may become waterlogged, or may receive excess of air. Frequent automatic opening of safety relief valve indicates water logging. High boiler temperature accompanied by unusually low radiation unit temperature (and “knocking”) indicates excess air in tank.

To correct:

1. Close valve between boiler and tank. Drain tank until empty.
2. Check all tank plugs and fittings. Tighten as necessary.
3. Open valve between boiler and tank. Water will rise to normal height in tank if you have automatic fill valve (otherwise, manually refill system).

**Boiler Flue Passages**

Recommend following checked annually by qualified service agent.

- flue passages
- burner adjustment
- operation of controls

Before start of each season (or whenever system has been shut down for some time) recheck whole system for leaks and recheck boiler and vent pipe for leaks. Replace or patch any boiler seals that are faulty. Before start of each season (or whenever system has been shut down for some time) recheck the whole system for leaks . . . and recheck the boiler and vent pipe for leaks. Replace or patch any boiler seals that are faulty.

**Vent Pipe**

Venting and piping should be checked at least monthly. If vent piping shows any sign of leaking, replace immediately.

**Water System**

If system is to remain out of service during freezing weather, always **drain it** completely (water left in to freeze will crack pipes and/or boiler).

**Cleaning Your Boiler And Burners**

Flue passages between sections should be examined yearly and cleaned if necessary.

To clean:

- Remove burners, pilot, and vent pipe.
- Remove top and front jacket panels.
- Remove two screws attaching intermediate front panel to left and right side jacket panels.
- Remove control panel as a unit.
- Remove draft diverter and intermediate front panel.
- Carefully remove cerafelt gasket strips.
- Clean passageways between sections with flexible handle wire brush. Remove dirt from bottom of boiler and from between sections by vacuuming.
- Verify all flame ports in burners are open and clear. Shake out or blow out all loose dirt in burners.
- Reseal seams between adjacent sections as necessary with 400° F RTV silicone sealant.
- Reassemble all parts.
- Verify tightness of pilot connections and condition of burner flames after reassembly. See Figures 15 and 16.
- Verify vent pipe connections to chimney are secure and no obstructions are present.

**Blower**

Blower motor features permanently lubricated ball bearing construction. Lubrication is not required.

**Circulator Pump Isolation Valves**

Operate isolation valves in circulator pump flanges manually once or twice per year to prevent valves from becoming stuck in open position

Rotate valves from open position to closed position and back to open position.

**Low Water Cutoff(s)**

Inspect field sourced low water cutoffs annually or as recommended by low water cutoff manufacturer. Flush float type low water cutoff(s) per manufacturer’s instructions.

**Housekeeping**

- Keep boiler area clear and free from combustible materials, gasoline and other flammable vapors and liquids.
- Keep boiler area clear of debris and other materials obstructing flow of combustion and ventilation air.



## SERVICE HINTS

**You may avoid inconvenience and service calls by checking these points before you call for service:**

 <b>CAUTION</b>
<b>WHAT TO DO IF YOU SMELL GAS</b>
<ul style="list-style-type: none"> <li>• Do not try to light any appliance.</li> <li>• Do not touch any electrical switch; do not use any phone in your building.</li> <li>• Immediately call your gas supplier from a neighbor's phone. Follow the gas supplier's instructions.</li> <li>• If you cannot reach your gas supplier, call the fire department.</li> </ul>

<b>IF YOUR SYSTEM IS NOT HEATING OR NOT GIVING ENOUGH HEAT . . .</b>	
<b>POSSIBLE CAUSE</b>	<b>WHAT TO DO</b>
Thermostat is not set correctly	Reset thermostat
Burner is not operating properly	Check flame. If it is yellow, the burner is not getting enough air. Or, if flame is blue and noisy and seems to lift off the burner, the burner is getting too much air. Contact your service technician.
No electric power to boiler	Check over-current protection. Check to be sure electric power supply circuit is "ON".
Controls out of adjustment	Reset according to instructions.
Radiators not heating	Open radiator vents to excess air. Check flow control valve (if used). It may be in closed position.
Circulating pump not running	Check over-current protection. Check relay operation.
Poor electrical contact	Check all control terminals and wire joints.
Chimney flue is blocked	Pressure switch will not close and pilot spark will not operate to start pilot. Have your service technician check and correct, if necessary.
Rollout switch blown	Have your service technician check heat exchanger for blockage. Replace rollout switch with exact replacement.
<b>IF BURNER IS NOISY . . .</b>	
<b>POSSIBLE CAUSE</b>	<b>WHAT TO DO</b>
Gas input amount is incorrect	Contact your service technician.
<b>RELIEF VALVE LEAKING . . .</b>	
<b>POSSIBLE CAUSE</b>	<b>WHAT TO DO</b>
Dirt on seat	Open valve manually. Allow water to run and clear valve seat.
Water logged expansion tank	Drain tank, see manufacturer instructions.
<b>HAVE YOUR SERVICE TECHNICIAN CHECK ANY PROBLEM YOU ARE UNABLE TO CORRECT.</b>	

**⚠ WARNING**

Burn and scald hazard. Safety relief valve could discharge steam or hot water during operation. Install discharge piping per these instructions.

**SAFETY RELIEF VALVE [Figure 2, Page 7]**

Safety relief valve is required on your boiler. Water expands as it is heated. If there is no place for water to expand into, water pressure will build up inside boiler and system. Should this happen, safety relief valve will automatically open at predetermined pressure. This will relieve the strain on boiler and system. Run pipe from relief valve outlet (pipe must be same size as outlet and open end must not be threaded) to open drain, tub or sink, or other suitable drainage point not subject to freezing. Failure to do so may cause water damage or injury should safety relief valve release.

**EXPANSION TANK**

Expanding water flows into expansion tank. Tank should be correct size. Tank is filled with air. As water expands it compresses air in the tank to form air pressure cushion. This "spring-like" cushion serves to maintain correct operating water pressure regardless of water temperature. This assures "full measure" of water, even in highest radiation unit of system. It also prevents blowing off of safety relief valve. Air in tank in beginning (with system filled with cold water) is sufficient for proper operation. Tank also serves as trap for excess air in system. Air would cause gurgling in pipes and in efficient circulation in radiators if left in system.

It is possible for tank to become "waterlogged" (filled with water). It can also become overfilled with air. This can happen after filling system with new water. Fittings provided on tank and in line to tank are for bleeding off excess water or air.

When installing this tank, it is important:

1. Tank be higher than boiler top.
2. Pipe to tank continuously rises up to tank (so air can "bubble" up to it).

**DIAPHRAGM TYPE EXPANSION TANK**

Diaphragm type expansion tank takes place of conventional expansion tank. Carefully read instructions packed with your tank assembly.

Tank comes with 10-12 pounds per square inch air charge. This is the same as pressure produced in system by automatic fill valve. When system is first filled, tank will contain little or no water.

As water is heated its pressure increases. It expands into tank, compressing air in tank. Compressed air cushion permits water in system to expand as temperature changes. Diaphragm type tank can be mounted on air purger fitting or at any convenient place in supply or return line.

**AIR ELIMINATING FITTING (AIR PURGER)**

Air purger is used to remove excess air from system. It is installed in supply line. It will eliminate air from water before it reaches radiators and bleed off this air.

**MAIN AIR VENT FOR DOWN FLOW SYSTEMS OR DIAPHRAGM TYPE EXPANSION TANK**

Before system is filled with water, there is air in pipes and radiation units. Some of it will be trapped as system is filled. It is possible to eliminate most of this air through air vent on radiation units. Main air vent will speed and simplify this. Install on highest point in supply main when all radiation is below top of boiler.

**AUTOMATIC FILL VALVE**

For a safe, efficient operation, hot water system must be **completely filled** with water. Adding new water, when needed can be done manually (by use of hand valve in water supply line). Requires regular attention to system's needs. Automatic fill valve accomplishes this without attention. Install in supply line on hot water boilers only. Valve operates through water pressure differentials. It does not require electrical connection.

**DRAIN VALVE**

Manual valve provides means of draining all water from boiler and system. It is often installed in 3/4" tapping at bottom of end boiler section. Or it can be installed in tee where return line enters boiler.

**WATER TEMPERATURE CONTROL**

Water temperature limit control in relay is adjustable and may be set as necessary. It may be set as low as 140°F, or as high as 220°F. This depends on type and amount of radiation involved and weather conditions.

**CIRCULATING PUMP**

Every forced hot-water system requires circulating pump. Separate pump or zone valve is required for each zone, if you have a two or more zone system. Pump must have capacity to provide circulation required by your system. Pump is connected into main just ahead of boiler. It is also wired to electrical system.

**BLOWER (Draft Inducer)**

Blower provides means for pulling air through boiler and exhausting flue gasses into vent system. Blower shuts off when burners are not firing. This keeps heat in house rather than having it go up chimney.

**PRESSURE SWITCH**

Air pressure switch works on negative pressure. When blower comes on air pressure switch operates intermittent pilot and gas valve. Air pressure switch is factory set and will only work when blower operates properly. It will not allow boiler to come on if blower does not generate enough pressure or if venting system is blocked.

Factory Pressure Switch Set point:

-0.4" wc. for 2-5 section boilers.

-0.5" w.c. for 6-7 section boilers.

**Rollout Switch****(FLAME ROLLOUT SAFETY SHUTOFF)**

Rollout switch is temperature-sensitive fuse link device. Located on boiler base just outside fire box. In event of heat exchanger flueway blockage causing flame to roll out of fire box, fuse does not change in appearance when blown.

If rollout switch blows, it must be replaced with exact replacement. Check heat exchanger flueways for blockage when restoring system to operating condition. DO NOT operate system without rollout switch.

**A.1 Installation Environment Considerations**

**⚠ WARNING**

**If you do not follow these instructions exactly, a fire or explosion may result causing property damage, personal injury or loss of life.**

- **Do not use this appliance if any part has been under water.** Immediately call a qualified service technician to inspect appliance and to replace any part of control system and any gas control which has been under water.
- Do not allow water to drip on controls. Prevent condensation by allowing air circulation around module and gas control.
- Do not use corrosive chemicals around or on module or gas control.

- Install plastic cover. Limits contamination from accumulation of dust or grease.
- Controls can be damaged by excessively high temperatures. Verify adequate air circulation around louvers is maintained when installing boiler.

**A.2 Electrical Connections**

**Connect Module Connectors Figure 11, Page 21**

- L1& L2 leads inside J box using wire nuts. Secure J box cover..
- Circulator harness to circulator. Harness comes plugged into module with Molex<sup>®</sup> plug.
- Thermostat connection to yellow wires marked TT using wire nuts.
- Ensure remaining Molex<sup>®</sup> plug connectors have not worked loose during transit.
- Check sensing bulb is fully inserted in well and is not loose.

**A.3 Adjusting Settings**

To discourage unauthorized changing of settings, procedure to enter adjustment mode is required.

To enter adjustment mode, press UP, DOWN, and I buttons (see Figure 1) simultaneously for three seconds. Press and release I button until parameter requiring adjustment is displayed:

- "SP\_" Setpoint (180 °F default setting; adjustable between 130 and 220 °F)
- "Df\_" Setpoint Differential (15 °F default setting; adjustable between 10 and 30 °F)
- "°F\_" Degrees Fahrenheit

Press UP or DOWN button until parameter has reached desired value. After 60 seconds without any button inputs, control automatically returns to READ mode.

**A.4 Display**

In RUN mode, status items and parameters are viewable.

*Example*, to display setpoint, control flashes "sp" (setpoint) followed by temperature (i.e., 135), followed by °F or °C.

To read settings, press and release I key to find parameter of interest.

*Example*, press and release I until setpoint (sp) is displayed, followed by three-digit number, i.e., 190, followed by °F or °C. Press I button again will display (S1T) Sensor 1 Temperature followed by three-digit number and corresponding degree designator. See Figure 17.

**Figure 17 - Display Readout**

Text	Description	Display Shows
sta	Current State	StA
s1t	Sensor 1 Temperature	S 1t
sp	Setpoint	SP
dff	Setpoint Differential	dFF
hr	Heat Request Status	hr
err	Error Code	Err
fla	Flame Current	FLA
°F	Degrees Fahrenheit	°F
°C	Degrees Celsius	°C
uA	Micro Amps	uA

**A.5 Operation**

Module continuously monitors boiler water temperature and fires or shuts off burner based on this temperature data.

1. When "Call for Heat" occurs, control enables circulator and monitors boiler water temperature to determine whether thermostat can be satisfied without firing burners.
2. Control determines burner operation is required, module proceeds to start burner (see state codes list) and heats water in boiler until setpoint temperature is achieved or thermostat is satisfied. .
3. Burner is de-activated, ignition module completes heating cycle, returns to idle and waits for temperature to drop again.
4. Circulator is turned on throughout "Call for Heat."

**Table 7 - Operation State Codes**

<b>State Code Number</b>	<b>Definition</b>	<b>Explanation</b>
1	Idle	Standby - no call for heat
	Circulator	Heat request present. Boiler temperature sufficiently high to run circulator pump only.
2	Wait for pressure switch to open	Inducer is off. Control waits for pressure switch to open. Checked at beginning of heat cycle before turning on inducer. If pressure switch does not open in 60 seconds, control goes to State 11.
3	Wait for pressure switch to close	Inducer is turned on. Control waits for pressure switch to close. Checked at beginning of heat cycle after turning on inducer. If pressure switch does not close in 60 seconds, control goes to State 12
4	Pre-purge	System is purging before ignition trial; includes Pilot Valve circuit diagnostics.
6	Spark	System sparking. Flame is not present
7	Flame stabilization	Flame signal is being established. Variation in signal is allowed during this state, flame must be stable at end of period
8	Running	System is running. Flame signal must be present.
9	Post-Purge	System is purging at end of call for heat
10	Retry delay	Successful ignition was not detected, and delay is called before retry.
	Recycle delay	Flame signal was lost, and delay is called before retry
11	Wait for pressure switch to open - failed to close	Inducer is still off. Pressure switch has not opened at beginning of heat cycle. Alarm is sent, but no lockout occurs
12	Wait for pressure switch to close - failed to open	Inducer is on. Pressure switch has not closed at beginning of heat cycle. Alarm message is sent but no lockout occurs.
13	Soft lock-out	Soft lockout duration is one hour, may override with manual reset.
14	Hard lock-out	Manual reset is required for hard lockout
15	Wait for limit to close	Possible thermostat call for heat; limit switch is open.
16	Flame out of sequence	Flame signal sensed before trial for ignition. Appropriate alarm is sent. OR
		Flame signal sensed during post purge. Appropriate alarm is sent. OR
		Flame signal present when not expected. Appropriate alarm is sent.
17	Pilot valve diagnostics	Pilot valve circuitry diagnostics during pre-purge.
	Current leakage detection	Self check performed at start up, again at beginning of heat cycle, and during "Wait for Recovery " State.
	Wait for recovery	Self check performed at start up, again at beginning of heat cycle, and during "Wait for Recovery " State

### A.6 Boiler High Limit Temperature Controller

- When water temperature reaches setpoint, controller ends heating cycle.
- When water temperature drops below setpoint minus differential, controller restarts heat cycle to re-heat boiler water.
- If water temperature exceeds maximum allowed temperature (220°F or 104°C), controller enters manual reset lockout state.
- For models having reset capability, press any onboard button or cycle power to reset.

**Figure 18 - Basic Control Algorithm Example**

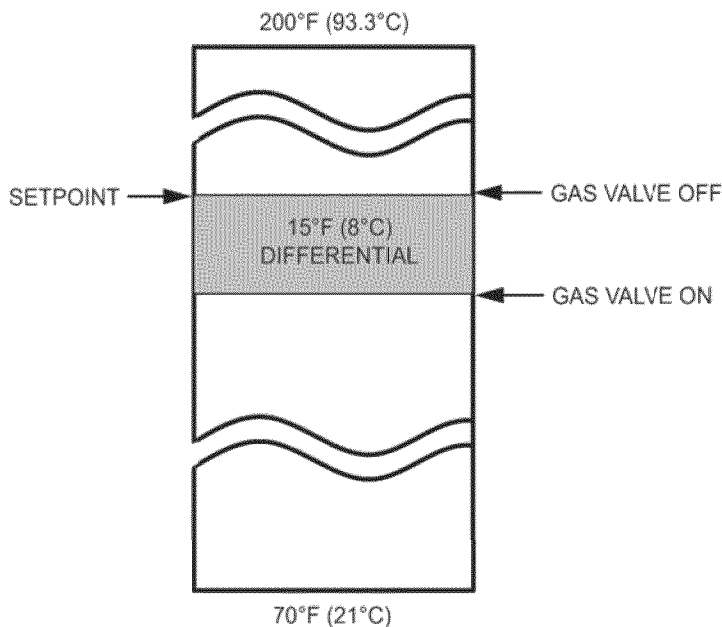

### A.7 Troubleshooting

- Following service procedures are provided as general guide.
- On lockout and retry models, meter readings between gas control and ignition module must be taken within trial for ignition period. Once ignition module shuts off, lockout models must be reset through key buttons and display. On retry models, wait for retry or reset at thermostat.
- Check for correct installation and wiring before replacing any component.
- Control module cannot be repaired. If it malfunctions, it must be replaced.
- Use only qualified service agent to service ignition systems.

1. Perform checkout as first step in troubleshooting.
2. Check troubleshooting guide to pinpoint cause of problem. See Table 8, page 35.
3. If troubleshooting indicates ignition problem, see Ignition System Checks to isolate and correct the problem.
4. Perform checkout procedure following troubleshooting guide again to verify system is operating normally.

### A.8 Troubleshooting Error Codes

Integrated boiler control uses advanced diagnostic capability to assist in troubleshooting error conditions. Table 8 shows codes that could arise on integrated display during fault.

Suggestions are provided in Table 8 for servicing these potential errors.

**Table 8 - Troubleshooting Error Codes**

Error Code Number	Definition	Consequence
2	Pressure switch failed to open (stuck closed).	Wait for recovery
4	Flame current too low. Check for flame.	Non critical alarm
6	Flame sensed out of normal sequence (before opening or after closing gas valve).	Soft lockout
18	Gas valve relays welded. Five consecutive soft lockouts.	Hard lockout
23	Flame sensed during prepurge ( before gas valve signaled opened).	Soft lockout
24	Flame sensed during postpurge (after gas valve signaled closed).	Soft lockout
29	Pressure switch failed to close (Contacts stuck open)	Wait for recovery
32	Sensor 1 error. Temperature sensor in well is not reading correctly. Verify it is connected to board. Replace if necessary.	Wait for recovery
57	Igniter flame rod shorted to burner ground	Wait for recovery
58	Igniter flame rod shorted to burner ground. Repair or replace igniter.	Wait for recovery
59	Line Voltage error - voltage out of specification high or low (15-37V (44-66Hz))	Wait for recovery
60	Applies only to thermostats having on-board transformer. Polarity is wrong in this case.	Wait for recovery
	Thermostat input higher than threshold.	
61	Line voltage unstable - possibly too may heavy loads switching on and off causing erratic supply voltage.	Wait for recovery
62	Soft lockout: maximum number of retries exceeded.	Soft lockout
	Soft lockout is reset after one hour if alarm reason disappears.	
63	Soft lockout: maximum number of recycles exceeded.	Soft lockout
64	Soft Lockout - electronics failure. On-board self diagnostics detected error.	Soft lockout
65	Over temperature error. Sensor measured temperature in excess of maximum allowable limit.	Soft lockout

Note: Soft lockout time is 1 hour or manual reset. Hard lockout requires manual reset.

**A.9 Intermittent Pilot**

Ignition System Checks

**STEP 1:** Check ignition cable.

- Verify ignition cable does not run in contact with metal surfaces.
- Verify only factory supplied Ignition cable (or approved replacement) is used.
- Verify connections to ignition module and igniter or igniter-sensor are clean and tight.
- Verify ignition cable provides good electrical continuity.

**STEP 2:**

Verify ignition system grounding. Nuisance shutdowns are often caused poor or erratic grounding.

Common ground is required for module and pilot burner/igniter sensor.

- Check for good metal-to-metal contact between pilot burner bracket and the main burner.
- Check ground lead from GND (BURNER) terminal on module to pilot burner. Verify connections are clean and tight. If wire is damaged or deteriorated, replace with No. 14-18 gauge, moisture-resistant, thermoplastic insulated wire with 105°C [221°F] minimum rating.
- Check ceramic flame rod insulator for cracks or evidence of exposure to extreme heat, which can permit leakage to ground. Replace pilot burner/igniter sensor and provide shield if necessary.
- If flame rod or bracket is bent out of position, restore to correct position.

**STEP 3:** Check spark ignition circuit.

**⚠ WARNING**

Electrical shock hazard. Ignition circuit generates over 10,000 volts. Turn OFF electrical power supply at service panel before making electrical connections. Failure to do so could result in death or serious injury.



Disconnect ignition cable at SPARK terminal on module. Energize module and listen for audible sparking noise. When operating normally, there should be buzzing noise turns on and off twice per second for duration of 1–7 seconds, depending on model.

**STEP 4:** Verify pilot and main burner lightoff.

- Initiate call for heat. Turn thermostat above room temperature. Ignition sequence may be delayed by thermal purge until boiler water temperature is below 140°F (60°C)
- Watch pilot burner during ignition sequence.
  - Verify ignition spark continues after pilot is lit.
  - Verify pilot lights and spark stops, verify main burner does not light.
- If so, ensure adequate flame current as follows.
  - Turn off boiler at circuit breaker or fuse box.
  - Clean flame rod with emery cloth.
  - Verify electrical connections are clean and tight. Replace damaged wire..
  - Check for cracked ceramic insulator, which can cause short to ground, and replace igniter-sensor if necessary.
  - At gas valve, disconnect main valve wire from MV terminal.
  - Turn on power and set thermostat to call for heat. Pilot should light, main burner will remain off because main valve actuator is disconnected.
  - Check pilot flame. Verify it is blue, steady and envelops 3/8 to 1/2 in. [10 to 13 mm] of flame rod. Figure 19 for possible flame problems and causes.
  - If necessary, adjust pilot flame by turning pilot. See Figure 15, Page 26. adjustment screw on gas control clockwise to decrease or counterclockwise to increase pilot flame. Following adjustment, always replace pilot adjustment cover screw and tighten firmly to assure proper gas control operation. See Figure 14, Page 26.
  - Set temperature below room set-point to end call for heat.

- Recheck ignition sequence as follows.
  - Reconnect main valve wire.
  - Adjust thermostat above room temperature.
  - Verify ignition sequence at burner.
  - If spark does not stop after pilot lights, replace module.
  - If main burner does not light or if main burner lights and system locks out, check module, ground wire and gas control as described in troubleshooting table. See Table 9, Page 35.

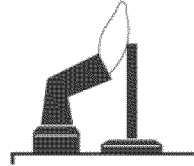
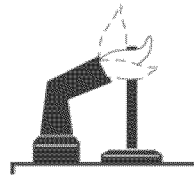
**Figure 19 - Pilot Flame**

APPEARANCE	CAUSE
<p>SMALL BLUE FLAME</p> 	<p>CHECK FOR LACK OF GAS FROM:</p> <ul style="list-style-type: none"> <li>• CLOGGED ORIFICE FILTER</li> <li>• CLOGGED PILOT FILTER</li> <li>• LOW GAS SUPPLY PRESSURE</li> <li>• PILOT ADJUSTMENT AT MINIMUM</li> </ul>
<p>LAZY YELLOW FLAME</p> 	<p>CHECK FOR LACK OF AIR FROM:</p> <ul style="list-style-type: none"> <li>• DIRTY ORIFICE</li> <li>• DIRTY LINT SCREEN, IF USED</li> <li>• DIRTY PRIMARY AIR OPENING, IF THERE IS ONE</li> <li>• PILOT ADJUSTMENT AT MINIMUM</li> </ul>
<p>WAVING BLUE FLAME</p> 	<p>CHECK FOR:</p> <ul style="list-style-type: none"> <li>• EXCESSIVE DRAFT AT PILOT LOCATION</li> <li>• RECIRCULATING PRODUCTS OF COMBUSTION</li> </ul>
<p>NOISY LIFTING BLOWING FLAME</p> 	<p>CHECK FOR:</p> <ul style="list-style-type: none"> <li>• HIGH GAS PRESSURE</li> </ul>
<p>HARD SHARP FLAME</p> 	<p>THIS FLAME IS CHARACTERISTIC OF MANUFACTURED GAS</p> <p>CHECK FOR:</p> <ul style="list-style-type: none"> <li>• HIGH GAS PRESSURE</li> <li>• ORIFICE TOO SMALL</li> </ul>

**Correct Pilot Flame: 3/8 to 1/2 inch in flame. See Figure 15, Page 26.**











---

**DUNKIRK BOILERS**  
2201 Dwyer Avenue, Utica NY 13501  
web site: [www.ecrinternational.com](http://www.ecrinternational.com)