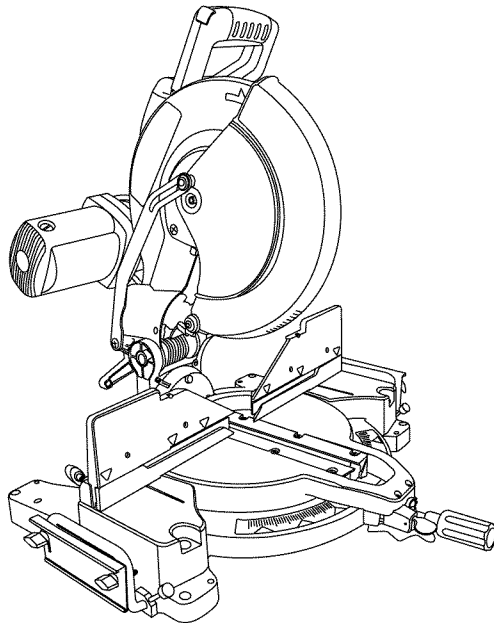


# Operator's Manual



## 12 IN. DUAL BEVEL COMPOUND MITER SAW WITH LASER TRAC® Model No. 137.375640



C US

### CAUTION:

Before using this Miter Saw, read this manual and follow all its Safety Rules and Operating Instructions

- Safety Instructions
- Assembly
- Operation
- Maintenance
- Parts List
- Español, p. 51

**Customer Help Line  
For Technical Support  
1-800-843-1682**

**Sears Parts &  
Repair Center  
1-800-488-1222**

Sears Brands Management Corporation Hoffman Estates, IL 60179 USA  
See the full line of Craftsman® products at [craftsman.com](http://craftsman.com)  
Click on the Craftsman Club® link and join today!  
Part No. 137.375640

Printed in China

# TABLE OF CONTENTS

SECTION	PAGE
Warranty .....	2
Product Specifications .....	3
Symbols.....	4
Power Tool Safety .....	5
Dual Bevel Compound Miter Saw Safety .....	8
Electrical Requirements and Safety .....	10
Accessories and Attachments .....	12
Tools Needed for Assembly .....	13
Carton Contents .....	14
Know Your Dual Bevel Compound Miter Saw .....	15
Glossary of Terms .....	16
Assembly.....	18
Adjustments .....	23
Operation .....	28
Maintenance .....	40
Troubleshooting Guide .....	42
Parts List .....	44
Repair Protection Agreement.....	48

## WARRANTY

### CRAFTSMAN FULL WARRANTY

FOR ONE YEAR from the date of purchase, this product is warranted against defects in material or workmanship. A defective product will receive free repair or replacement if repair is unavailable. For warranty coverage details or to obtain free repair or replacement, visit the web site: [www.craftsman.com](http://www.craftsman.com)

This warranty does not cover the blade, which is an expendable part that can wear out from normal use within the warranty period. This warranty is void if this product is ever used while providing commercial services or if rented to another person. This warranty gives you specific legal rights, and you may also have other rights which vary from state to state.

**Sears Brands Management Corporation Hoffman Estates, IL 60179**

### **WARNING**

Some dust created by power sanding, sawing, grinding, drilling and other construction activities contains chemicals known to the state of California to cause cancer, birth defects or other reproductive harm. Some examples of these chemicals are:

- Lead from lead-based paints,
- Crystalline silica from bricks and cement and other masonry products, and
- Arsenic and chromium from chemically-treated lumber.

Your risk from these exposures varies, depending on how often you do this type of work. To reduce your exposure to these chemicals: work in a well ventilated area, and work with approved safety equipment, such as those dust masks that are specially designed to filter out microscopic particles.

# PRODUCT SPECIFICATIONS

## MOTOR

Power Source .....	120V AC, 60Hz, 15 Amp
Arbor Shaft Size .....	5/8 in.
Speed .....	3800 RPM (No load)
Brake .....	Electric

## MITER SAW

Miter Detent Stops .....	0°, 15°, 22.5°, 31.6°, 45° R & L
Bevel Positive Stops .....	0°, 45° L

### Cutting Capacity:

Crosscut (Maximum Width) .....	3 in. x 7-7/8 in.
Crosscut (Maximum Height) .....	3-1/2 in. x 5-1/2 in.
45° Miter Cut R & L .....	3 in. x 5-1/2 in.
45° Bevel L .....	1-7/8 in. x 7-7/8 in.
45° Miter and 45° Bevel .....	1-1/2 in. x 5-1/2 in.

## BLADE

Diameter .....	12 in.
Arbor Hole .....	1 in. dia. w/ 5/8 in. reducer

## WARNING

To avoid electrical hazards, fire hazards or damage to the tool, use proper circuit protection.

This tool is wired at the factory for 110-120 Volt operation. It must be connected to a 110-120 Volt / 15 Ampere time delay fuse or circuit breaker. To avoid shock or fire, replace power cord immediately if it is worn, cut or damaged in any way. Before using your tool, it is critical that you read and understand these safety rules. Failure to follow these rules could result in serious injury to you or damage to the tool.

# SYMBOLS

## WARNING ICONS

Your power tool and its Operator's Manual may contain "WARNING ICONS" (a picture symbol intended to alert you to, and/or instruct you how to avoid, a potentially hazardous condition). Understanding and heeding these symbols will help you operate your tool better and safer. Shown below are some of the symbols you may see.



**SAFETY ALERT:** Precautions that involve your safety.



**PROHIBITION**



**WEAR EYE PROTECTION:** Always wear safety goggles or safety glasses with side shields.



**WEAR RESPIRATORY AND HEARING PROTECTION:** Always wear respiratory and hearing protection.



**READ AND UNDERSTAND OPERATOR'S MANUAL:** To reduce the risk of injury, user and all bystanders must read and understand operator's manual before using this product.



**KEEP HANDS AWAY FROM BLADE:** Failure to keep your hands away from the blade will result in serious personal injury.



**SUPPORT AND CLAMP WORK**



**DANGER:** indicates an imminently hazardous situation which, if not avoided, will result in death or serious injury.



**WARNING:** indicates a potentially hazardous situation which, if not avoided, could result in death or serious injury.



**CAUTION:** indicates a potentially hazardous situation which, if not avoided, may result in minor or moderate injury.



**CAUTION:** used without the safety alert symbol indicates a potentially hazardous situation which, if not avoided, may result in property damage.


# POWER TOOL SAFETY




## GENERAL SAFETY INSTRUCTIONS BEFORE USING THIS POWER TOOL



Safety is a combination of common sense, staying alert and knowing how to use your power tool.

### **WARNING**

To avoid mistakes that could cause serious injury, do not plug the tool in until you have read and understood the following.

-  **1. READ** and become familiar with the entire Operator's Manual. **LEARN** the tool's application, limitations and possible hazards.
- 2. KEEP GUARDS IN PLACE** and in working order.
- 3. REMOVE ADJUSTING KEYS AND WRENCHES.** Form the habit of checking to see that keys and adjusting wrenches are removed from the tool before turning ON.
- 4. KEEP WORK AREA CLEAN.** Cluttered areas and benches invite accidents.
- 5. DO NOT USE IN DANGEROUS ENVIRONMENTS.** Do not use power tools in damp locations, or expose them to rain or snow. Keep work area well lit.
- 6. KEEP CHILDREN AWAY.** All visitors and bystanders should be kept a safe distance from work area.
- 7. MAKE WORKSHOP CHILD PROOF** with padlocks, master switches or by removing starter keys.
- 8. DO NOT FORCE THE TOOL.** It will do the job better and safer at the rate for which it was designed.
- 9. USE THE RIGHT TOOL.** Do not force the tool or an attachment to do a job for which it was not designed.
- 10. USE PROPER EXTENSION CORDS.** Make sure your extension cord is in good condition. When using an extension cord, be sure to use the one heavy enough to carry the current that the product will draw. An undersized cord will result in a drop in line voltage and in loss of power which will cause the tool overheat. The table on page 11 shows the proper wire gauge size usage to each extension cord length and ampere rating. If in doubt, use the next heavier gauge. The smaller the gauge number, the heavier the cord.
- 11. WEAR PROPER APPAREL.** Do not wear loose clothing, gloves, neckties, rings, bracelets or other jewelry which may get caught in moving parts. Nonslip footwear is recommended. Wear protective hair covering to contain long hair.

12.  **ALWAYS WEAR EYE PROTECTION.** Any power tool can throw foreign objects into the eyes and could cause permanent eye damage. **ALWAYS** wear Safety Goggles (not glasses) that comply with ANSI Safety standard Z87.1. Everyday eyeglasses have only impact-resistant lenses. They **ARE NOT** safety glasses. Safety Goggles are available at Sears. **NOTE:** Glasses or goggles not in compliance with ANSI Z87.1 could seriously injure you when they break.
13.  **WEAR A FACE MASK OR DUST MASK.** Sawing operation produces dust.
14.  **SECURE WORK.** Use clamps or a vise to hold work when practical. It is safer than using your hand and it frees both hands to operate the tool.
15. **DISCONNECT TOOLS FROM POWER SOURCE** before servicing, and when changing accessories such as blades, bits and cutters.
16. **REDUCE THE RISK OF UNINTENTIONAL STARTING.** Make sure switch is in the OFF position before plugging the tool in.
17. **USE RECOMMENDED ACCESSORIES.** Consult this Operator's Manual for recommended accessories. The use of improper accessories may cause risk of injury to yourself or others.
18. **NEVER STAND ON THE TOOL.** Serious injury could occur if the tool is tipped or if the cutting tool is unintentionally contacted.
19. **CHECK FOR DAMAGED PARTS.** Before further use of the tool, a guard or other part that is damaged should be carefully checked to determine that it will operate properly and perform its intended function – check for alignment of moving parts, binding of moving parts, breakage of parts, mounting and any other conditions that may affect its operation. A guard or other part that is damaged should be properly repaired or replaced.
20. **NEVER LEAVE THE TOOL RUNNING UNATTENDED. TURN THE POWER “OFF”.** Do not walk away from a running tool until the blade comes to a complete stop and the tool is unplugged from the power source.
21. **DO NOT OVERREACH.** Keep proper footing and balance at all times. NEVER reach your arm or hand across the path of the blade.
22. **MAINTAIN TOOLS WITH CARE.** Keep tools sharp and clean for best and safest performance. Follow instructions for lubricating and changing accessories.

23. **DO NOT** use power tool in presence of flammable liquids or gases.
24. **DO NOT** operate the tool if you are under the influence of any drugs, alcohol or medication that could affect your ability to use the tool properly.
25. **WARNING:** Dust generated from certain materials can be hazardous to your health. Always operate saw in well-ventilated area and provide for proper dust removal.
26.  **DANGER** People with electronic devices, such as pacemakers, should consult their physician(s) before using this product. Operation of electrical equipment in close proximity to a heart pacemaker could cause interference or failure of the pacemaker.
27.  **WEAR HEARING PROTECTION** to reduce the risk of induced hearing loss.

# DUAL BEVEL COMPOUND MITER SAW SAFETY

## SPECIFIC SAFETY INSTRUCTIONS FOR THIS COMPOUND MITER SAW

1. **DO NOT** operate the miter saw until it is completely assembled and installed according to these instructions.
2. **IF YOU ARE NOT** thoroughly familiar with the operation of miter saws, seek guidance from your supervisor, instructor or other qualified person.
3. **ALWAYS** hold the work firmly against the fence and table. **DO NOT** perform any operation freehand (use clamp wherever possible).
4. **KEEP HANDS** out of the path of the saw blade. If the workpiece you are cutting would cause your hands to be within 8-3/25 in. of the saw blade, the workpiece should be clamped in place before making the cut.
5. **MAKE SURE** the blade is sharp, runs freely and is free of vibration.
6. **ALLOW** the motor to come up to full speed before starting a cut.
7. **KEEP THE MOTOR AIR SLOTS CLEAN** and free of chips or dust.
8. **ALWAYS MAKE SURE** all handles are tight before cutting, even if the table is positioned in one of the positive stops.
9. **MAKE SURE** both the blade and the collar are clean and the arbor bolt is tightened securely.
10. **USE** only blade collars specified for your saw.
11. **NEVER** use blades larger than 12 inches in diameter.
12. **NEVER** apply lubricants to the blade when the saw is running.
13. **ALWAYS** check the blade for cracks or damage before operation. Replace a cracked or damaged blade immediately.
14. **NEVER** use blades recommended for operation at less than 4800 RPM.
15. **ALWAYS** keep the blade guards in place and use at all times.
16. **NEVER** reach around the saw blade.
17. **MAKE SURE** the blade is not in contact with the workpiece before the switch is turned ON.
18. **IMPORTANT:** After completing a cut, release the trigger switch and wait for the blade to stop before returning the saw to the raised position.
19. **MAKE SURE** the blade has come to a complete stop before removing or securing the workpiece, changing the workpiece angle or changing the angle of the blade.



20. **NEVER** cut metals or masonry products with this tool. This miter saw is designed for use on wood and wood-like products.
21. **NEVER** cut small pieces. If the workpiece being cut would cause your hand or fingers to be within 8-3/25 in. of the saw blade, the workpiece is too small.
22. **PROVIDE** adequate support to the sides of the saw table for long workpieces.
23. **NEVER** use the miter saw in areas with flammable liquids or gases.
24. **NEVER** use solvents to clean plastic parts. Solvents could possibly dissolve or otherwise damage the material.
25. **SHUT OFF** the power before servicing or adjusting the tool.
26. **DISCONNECT** the saw from the power source and clean the machine when finished using.
27. **MAKE SURE** the work area is clean before leaving the machine.
28. **SHOULD** any part of your miter saw become missing, damaged, fail in any way or any electrical component fail to perform properly, shut off the switch and remove the plug from the power supply outlet. Replace missing, damaged or failed parts before resuming operation.

# ELECTRICAL REQUIREMENTS AND SAFETY

## POWER SUPPLY AND MOTOR SPECIFICATIONS

The AC motor used in this saw is a universal, nonreversible type. See “MOTOR” in the “PRODUCT SPECIFICATIONS” section on page 3.

### **WARNING**

**To avoid electrical hazards, fire hazards, or damage to the tool, use proper circuit protection. Your saw is wired at the factory for 120 V operation. Connect to a 120 V, 15 Amp circuit and use a 15 Amp time delay fuse or circuit breaker. To avoid shock or fire, if power cord is worn or cut, or damaged in any way, have it replaced immediately.**

## GROUNDING INSTRUCTIONS

**IN THE EVENT OF A MALFUNCTION OR BREAKDOWN**, grounding provides a path of least resistance for electric currents and reduces the risk of electric shock. This tool is equipped with an electrical cord that has an equipment-grounding conductor and a grounding plug. The plug must be plugged into a matching receptacle that is properly installed and grounded in accordance with all local codes and ordinances.

**DO NOT MODIFY THE PLUG PROVIDED.** If it will not fit the receptacle, have the proper receptacle installed by a qualified electrician.

**IMPROPER CONNECTION** of the equipment grounding conductor can result in risk of electric shock. The conductor with the green insulation (with or without yellow stripes) is the equipment grounding conductor. If repair or replacement of the electrical

cord or plug is necessary, do not connect the equipment grounding conductor to a live terminal.

**CHECK** with a qualified electrician or service person if you do not completely understand the grounding instructions, or if you are not certain the tool is properly grounded.

**USE** only three-wire extension cords that have three-pronged grounding plugs with three-pole receptacles that accept the tool’s plug. Repair or replace damaged or worn cords immediately.

## GUIDELINES FOR EXTENSION CORDS

**USE THE PROPER EXTENSION CORD.** Make sure your extension cord is in good condition. Use an extension cord heavy enough to carry the current your product will draw. An undersized cord will cause a drop in line voltage resulting in loss of power, overheating and burning out of the motor. The table on the right shows the correct size to use depending on cord length and nameplate ampere rating. If in doubt, use the next heavier gauge. The smaller the gauge number, the heavier the cord.

Make sure your extension cord is properly wired and in good condition. Always replace a damaged extension cord or have it repaired by a qualified technician before using it. Protect your extension cords from sharp objects, excessive heat and damp or wet areas. Use a separate electrical circuit for your tool. This circuit must not be less than #12 wire with a 20 Amp time-lag fuse or a #14 wire with a 15 Amp time-lag fuse.

**NOTE:** When using an extension cord on a circuit with a #14 wire, the extension cord must not exceed 25 feet in length. Before connecting the motor to the power line, make sure the switch is in the off position and the electric current is rated the same as the current stamped on the motor nameplate. Running at a lower voltage will damage the motor. This tool is intended for use on a circuit that has a receptacle like the one illustrated in Fig. 1.

**Fig. 1**

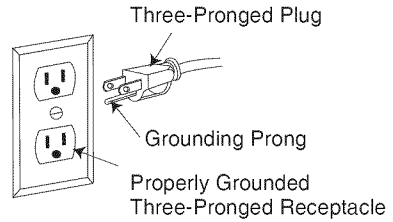
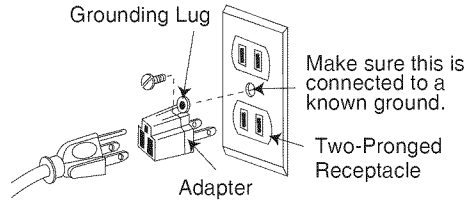


Fig. 1 shows a three-pronged electrical plug and receptacle that has a grounding conductor. If a properly grounded receptacle is not available, an adapter (sold separately) (Fig. 2) can be used to temporarily connect this plug to a two-contact grounded receptacle. The adapter (Fig. 2) has a rigid lug extending from it that **MUST** be connected to a permanent earth ground, such as a properly grounded receptacle box.

**Fig. 2**



<b>MINIMUM GAUGE FOR EXTENSION CORDS (AWG)</b>					
(When using 120 volts only)					
<b>Ampere Rating</b>		<b>Total length of Cord</b>			
More Than	Not More Than	25ft.	50ft.	100ft.	150ft.
0	6	18	16	16	14
6	10	18	16	14	12
10	12	16	16	14	12
12	16	14	12	Not Recommended	

**▲ CAUTION**

- In all cases, make certain the receptacle is properly grounded. If you are not sure, have a qualified electrician check the receptacle.
- This tool is for indoor use only. Do not expose to rain or use in damp locations.
- This tool must be grounded while in use to protect the operator from electric shock.
- Never remove the grounding prong from the power cord. If damaged, discontinue use of unit and contact customer service for a replacement cord.

# ACCESSORIES AND ATTACHMENTS

## RECOMMENDED ACCESSORIES

### WARNING

- Use only accessories recommended for this miter saw. Follow instructions that accompany accessories. Use of improper accessories may cause hazards.
- The use of any cutting tool except 12 in. saw blades which meet the requirements under recommended accessories is prohibited. Do not use accessories such as shaper cutters or dado sets. Ferrous metal cutting and the use of abrasive wheels is prohibited.
- Do not attempt to modify this tool or create accessories not recommended for use with this tool. Any such alteration or modification is misuse and could result in a hazardous condition leading to possible serious injury.

## ACCESSORIES

Visit your Sears Hardware Department or see the Sears Power and Hand Tool Catalog to purchase recommended accessories for this power tool.

### WARNING

- To avoid the risk of personal injury, do not modify this power tool or use accessories not recommended by Sears.
- Read warnings and conditions on your CARBIDE TIPPED SAW BLADE. Do not operate the saw without the proper saw blade guard in place. Carbide is a very hard but brittle material. Care should be taken while mounting, using, and storing carbide tipped blades to prevent accidental damage. Slight shocks, such as striking the tip while handling, can seriously damage the blade. Foreign objects in the workpiece, such as wire or nails, can also cause tips to crack or break off. Before using,

always visually examine the blade and tips for bent blade, cracks, breakage, missing or loose tips, or other damage. Do not use if damage is suspected. Failure to heed safety instructions and warnings can result in serious bodily injury.

## BLADE INFORMATION

- Always use a crosscut blade that is designed for cutting across the wood grain. NEVER use Rip, Combination, Plywood, Dado or Abrasive type saw blades at any time
- Always use a 12in diameter blade with either a 1" or 5/8" arbor hole, speed rating must be at least 4800 RPM.
- Read and understand all instructions provided with each blade before using on this miter saw.

There are two main materials used for saw blades; high-speed steel (HSS) and carbide tipped (TCT). While the HSS blades are generally less expensive than carbide tipped, TCT blades will stay sharper longer than HSS. As a general rule the more teeth per inch (TPI) the smoother the cut. Please read the information provided on the blade for more details for their use.

General Purpose Wood Cutting: 24 - 40 TPI  
Fine Woodworking Cutting: 60 - 80 TPI  
Non-ferrous Metal Cutting:

Use only special blades designed for cutting this type of material.

Plastic Cutting:

Use only special blades designed for cutting plastic.

**NOTE:** When cutting non-ferrous or plastic, be sure to clean up completely after each use. Take special care with metal shavings after each cut, these can cause damage to the table top. ALWAYS WEAR EYE PROTECTION.

# TOOLS NEEDED FOR ASSEMBLY

## Supplied

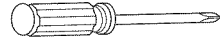


Blade Wrench

## Not supplied



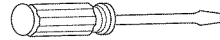
Adjustable Wrench



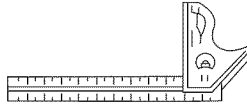
Phillips Screwdriver



6 mm Hex Wrench



Slotted Screwdriver



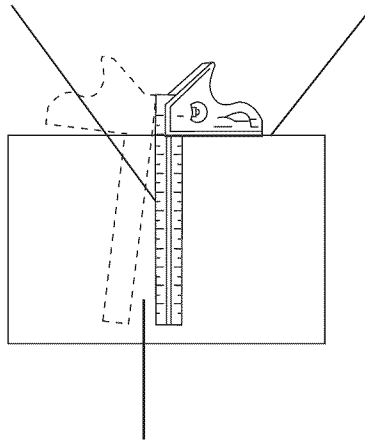
Combination Square

## COMBINATION SQUARE MUST BE TRUE

Should not gap or overlap when square is flipped over (see dotted figure).

Draw light line on board along this edge.

Straight edge on a 3/4 in. board - this edge must be perfectly straight.



Should not gap or overlap when square flipped over (see dotted figure).

# CARTON CONTENTS

## UNPACKING YOUR MITER SAW

### WARNING

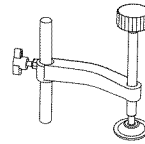
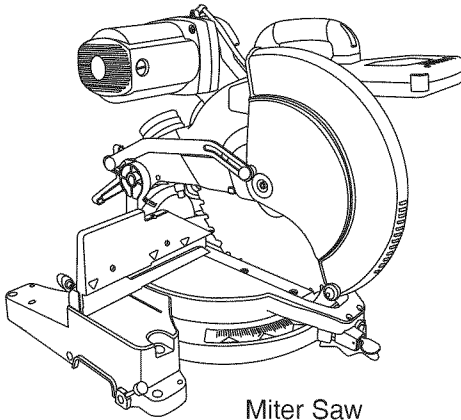
To avoid injury from unexpected starting or electrical shock, do not plug the power cord into a source of power during unpacking and assembly. This cord must remain unplugged whenever you are working on the saw.

1. Remove the miter saw from the carton.  
**IMPORTANT:** Do not lift miter saw by the trigger switch handle. It may cause misalignment. Only lift machine by the base hand holds.

2. Place the saw on a secure stationary work surface.
3. Separate all parts from the packing material. Check each one with the illustration to make certain all items are accounted for before discarding any packing material.

### WARNING

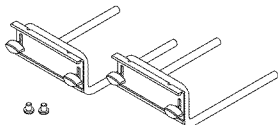
- If any part is missing or damaged, do not attempt to assemble the miter saw, or plug in the power cord until the missing or damaged part is correctly replaced. To avoid electric shock, use only identical replacement parts when servicing double insulated tools. Call 1-800-4-MY-HOME® for replacement parts.



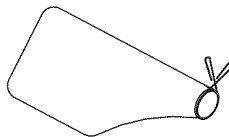
Hold-down Clamp



AAA Batteries



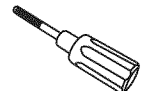
Extension Wings



Dust Bag

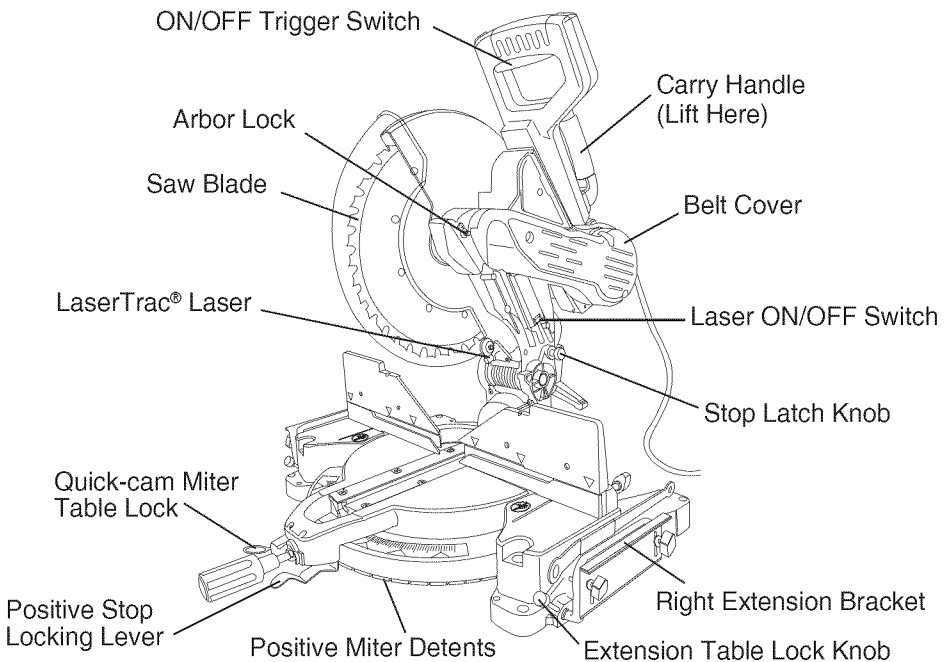
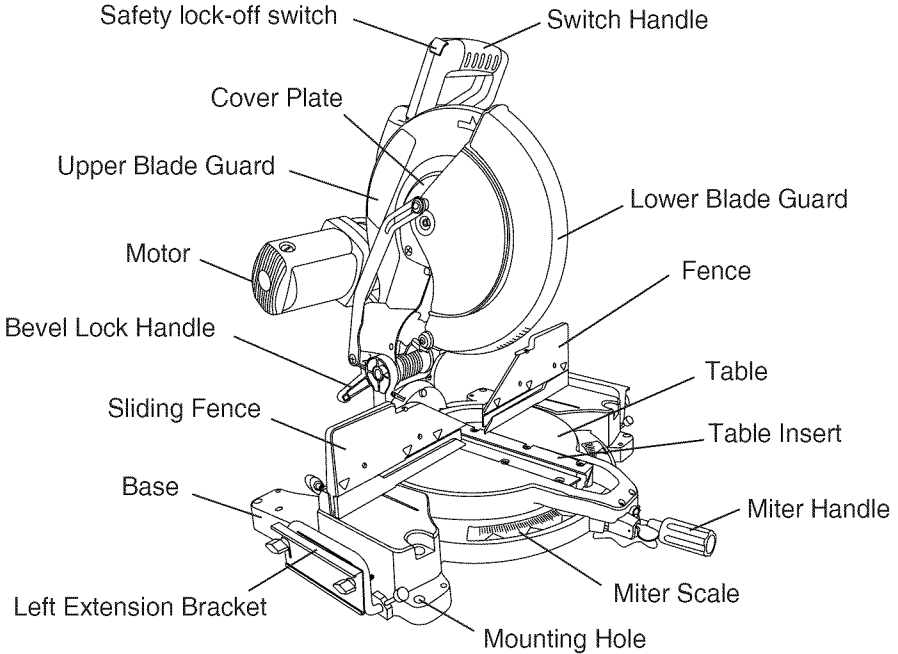


Blade Wrench



Miter Handle

# KNOW YOUR DUAL BEVEL COMPOUND MITER SAW



# GLOSSARY OF TERMS

**AMPERAGE (AMPS)** – A measure of the flow of electric current. Higher ratings generally means the tool is suited for heavier use.

**ARBOR LOCK** – Allows the user to keep the blade from rotating while tightening or loosening the arbor bolt during blade replacement or removal.

**BASE** – Supports the table, holds accessories and allows for workbench or leg set mounting.

**BEVEL LOCKING HANDLE** – Locks the miter saw at a desired bevel angle.

**BEVEL SCALE** – To measure the bevel angle of the saw blade 0° to 45° left.

**CARBIDE TIPPED** – Extremely hard steel pieces with sharp cutting edges fastened to cutting tools such as saw blades.

**COVER PLATE SCREW** – Loosen this screw and rotate the plate for access to the blade arbor bolt.

**DOUBLE-INSULATED** – A form of electrical protection featuring two separate insulation systems to help protect against electrical shock.

**EXTENSION CORD** – An electric cord used between power tools and outlets to extend the range of the tools. The more amperage your tool uses or the longer the distance from tool to outlet, the larger size of the wire needed in your extension cord.

**EYE PROTECTION** – Goggles or spectacles intended to protect your eyes. Eye protection should meet the requirements of ANSI Z.87.1 (USA) or CSA Z94.3-M88 (Canada).

**FACE SHIELD** – An impact resistant shield that helps to protect your face from chips, sparks, small debris. Should only be used in conjunction with additional eye protection.

**FENCE** – Helps to keep the workpiece from moving when sawing. Scaled to assist with accurate cutting.

**GUARD** – Protective device that forms a barrier between a hazardous object such as a blade, wheel or cutter and the operator.

**HOLD DOWN LATCH** – Locks the miter saw in the lowered position for compact storage and transportation.

**INSTRUCTION OR OPERATOR'S MANUAL** – Booklet accompanying your power tool that describes the hazards and safe operation procedures, and outlines basic tool operation, care and maintenance.

**MITER HANDLE** – Used to rotate the table, and to rotate the saw to a right or left cutting position.

**MITER SCALE** – Measures the miter angle 0° to 45° left and right.

**MOUNTING HOLES** – To mount the miter saw to a stable surface.

**ON/OFF TRIGGER SWITCH** – To start the tool, squeeze the trigger. Release the trigger to turn off the miter saw.



**POSITIVE STOP LOCKING LEVER** – Locks the miter saw at a preset positive stop for the desired miter angle.

**SWITCH HANDLE** – The switch handle contains the trigger switch and the laser on/off switch. The blade is lowered into the workpiece by pushing down on the handle. The saw will return to its upright position when the handle is released.

**WARNING LABELS** – Read and understand for your own safety. Make sure all labels are present on machine and legible.

**WRENCH STORAGE** – Convenient storage to prevent misplacing the blade wrench.

## **WOODWORKING TERMS**

**ARBOR** – The shaft on which a blade is mounted.

**BEVEL CUT** – An angle cut made through the face of the workpiece.

**COMPOUND CUT** – An angled cut to both the edge and face of a board, most common use is with crown molding.

**CROSS CUT** – A cut which runs across the board perpendicular to the grain.

**FREEHAND** – Performing a cut without using a fence (guide), hold down or other proper device to prevent the workpiece from twisting during the cutting operation.

**HEEL** – Misalignment of the blade.

**KERF** – The width of a saw cut, determined by the thickness and set of the blade.

**KICKBACK** – Sudden and unintended movement of the tool or workpiece. It is typically caused by binding or pinching of the workpiece.

**MITER CUT** – A miter is a type of joint where the two parts to be joined are cut at an angle, and typically the finished joint forms a 90-degree angle.

**REVOLUTIONS PER MINUTE (RPM)** – The number of turns completed by a spinning object in one minute.

**SAW BLADE PATH** – The area of the workpiece or table top directly in line with the travel of the blade or the part of the workpiece which will be cut.

**SET** – The distance between two saw blade tips, bent outward in opposite directions to each other. The further apart the tips are, the greater the set.

**THIN-KERF BLADE** – Thinner than normal blades, remove less material, smaller kerfs (between .065 in. and .070 in.). Blade thinness also may increase the heat generated while cutting.

**WORKPIECE** – The wood being cut. The surfaces of a workpiece are commonly referred to as faces, ends and edges.

# ASSEMBLY

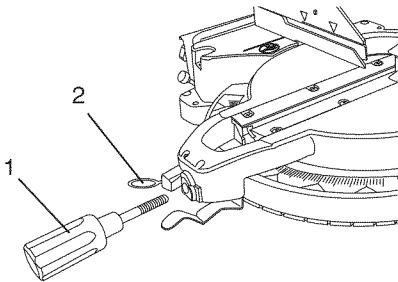
## **⚠ WARNING**

To avoid injury, do not connect this miter saw to the power source until it is completely assembled and adjusted and you have read and understood this Operator's Manual.

### INSTALLING THE MITER HANDLE (FIG. A)

1. Thread the miter handle (1) into the hole (2) located at the front of the miter table.

Fig. A



## **⚠ WARNING**

- To avoid injury and damage to the saw, transport or store the miter saw with the cutting head locked in the down position. Never use the stop latch to hold the cutting head in a down position for cutting operations.
- To avoid damage, never carry the miter saw by the switch handle, the cutting arm or the miter table handle. Always use the designated carrying handle.

### CUTTING HEAD (FIG. B)

#### Raising

1. Push down slightly on the switch handle (1).

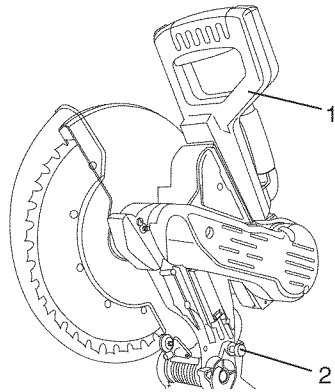
2. Pull out the stop latch knob (2).
3. Allow the cutting head to rise to the up position.

#### Locking

When transporting or storing the miter saw, the cutting head should always be locked in the down position.

1. Push the cutting head down to its lowest position.
2. Push the stop latch knob (2) into the locking hole.

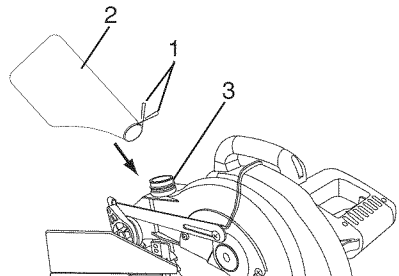
Fig. B



### INSTALLING THE DUST BAG (FIG. C)

1. Squeeze the metal collar wings (1) of the dust bag (2).
2. Place the dust bag neck opening around the exhaust port (3), and release the metal collar wings.

Fig. C



To empty the dust bag, squeeze the metal collar and remove from exhaust port. Open zipper on underside of bag and empty into waste container.

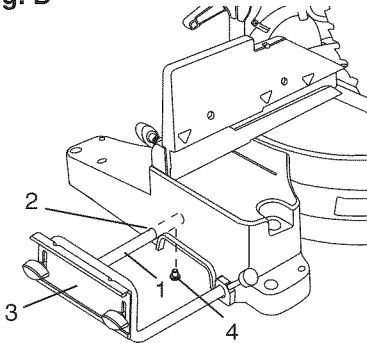
**NOTE:** Check frequently, and empty bag before it gets full.

**NOTE:** Remove bag when cutting non-ferrous metal workpieces.

### INSTALLING THE EXTENSION WING ASSEMBLY (FIG. D)

1. Insert the extension wing bars (1) into the holes (2) in the base.
2. Thread one extension wing stop screw (4) into the end of the rear extension wing bar (1). Verify that the screw is fully threaded into the corresponding hole in the extension wing.
3. Repeat steps 1 through 2 for the other side extension wing.

**Fig. D**

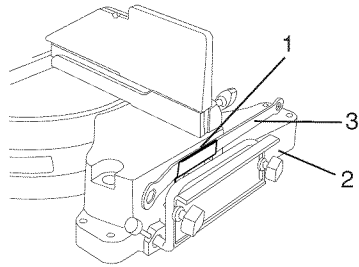


**NOTE:** The arm brackets (3) serve two purposes: To act as a stop block for repetitive cuts and to level the workpiece when the extension wings are fully extended for additional work support.

### SAW BLADE WRENCH (FIG. E)

1. For convenient storage and prevention of loss, there is a slot (1) in the right side of saw base (2) for storing the blade wrench (3) when not in use.

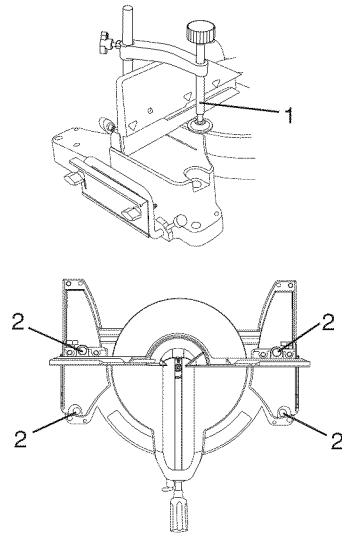
**Fig. E**



### INSTALLING THE SAFETY HOLD-DOWN CLAMP (FIG. F)

1. Place the hold-down clamp assembly (1) in one of the mounting holes (2) as shown.

**Fig. F**



### **▲ WARNING**

- Only use a 12 in. diameter blade.
- To avoid injury from an accidental start, make sure the switch is in the OFF position and plug is not connected to the power source.

## INSERTING AND REPLACING THE LASER BATTERIES (FIG. G)

- Unplug your miter saw.

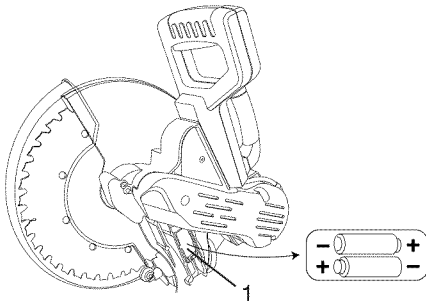
### **⚠ WARNING**

Failure to unplug your tool could result in accidental starting and cause possible serious personal injury.

1. Open the battery cover (1).
2. Insert the two supplied AAA batteries in the case as per the diagram below. If replacing the batteries, take out the old batteries and place with new AAA batteries. Dispose of old batteries properly.
3. Close the battery cover (1).

**NOTE:** Replace the batteries with batteries that have a rating of 1.5 V (Number 4 series and AAA size or equivalent).

**Fig. G**



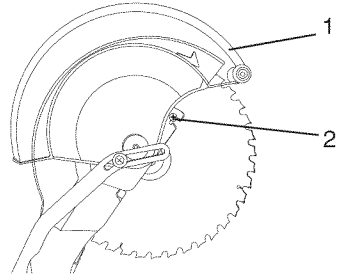
## REMOVING AND INSTALLING THE BLADE

### Removing Blade (Fig. H, I, J, K)

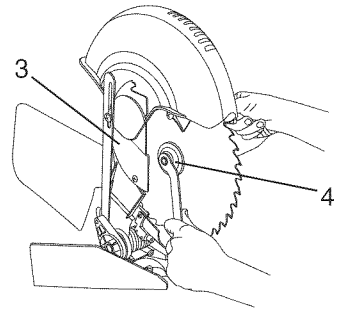
1. Unplug the saw from the outlet.
2. Allow the blade assembly to rise to the uppermost position. Raise the lower blade guard (1) to the upper position.
3. Loosen the cover plate screw (2) using a star-head screwdriver.
4. Rotate the cover plate (3) to expose the arbor bolt (4).

5. Place the blade wrench over the arbor bolt.

**Fig. H**

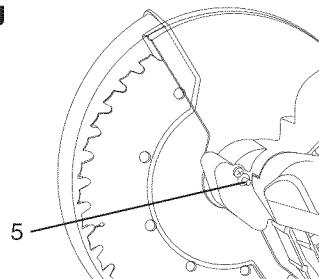


**Fig. I**



6. Locate the arbor lock (5) on the motor below the miter saw switch handle.
7. Press the arbor lock, holding it in firmly while turning the blade wrench clockwise. The arbor lock will engage after turning the wrench. Continue to hold the arbor lock to keep it engaged while turning the wrench clockwise to loosen the arbor bolt.

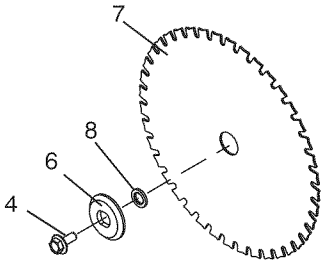
**Fig. J**



- Remove the arbor bolt/washer (4), outer blade collar (6) and the blade (7). Do not remove the inner blade collar. (Fig. K)

**NOTE:** Pay attention to the pieces removed, noting their position and direction they face. Wipe the blade collars clean of any sawdust before installing a new blade. Also, the 12 in. blade has a 1 in. arbor hole with a 5/8 in. reducer (8) to mount onto the saw.

**Fig. K**



### Installing Blade (Fig. H, I, J, K)

Unplug the miter saw before changing/installing the blade.

- Install a 12 in. blade with a 5/8 in. arbor (or a 1 in. arbor with a 5/8 in. reducer), making sure the rotation arrow on the blade matches the clockwise rotation arrow on the upper guard and the blade teeth are pointing downward.
- Place the blade collar (6) against the blade and on the arbor. Thread the arbor bolt (4) onto the arbor in a counter-clockwise direction. (Fig. K) **IMPORTANT:** Make sure the flats of the blade collars are engaged with the flats on the arbor shaft. Also, the flat-side of the collar must be placed against the blade.
- Place the blade wrench on the arbor bolt.

- Press the arbor lock (5), holding it in firmly while turning the blade counter-clockwise. When it engages, continue to press the arbor lock in while tightening the arbor bolt securely. (Fig. J)
- Rotate the cover plate (3) back to its original position until the slot in the cover plate engages with the cover plate screw (2). While holding the lower blade guard, tighten the screw with a star-head screwdriver. (Fig. H, I) **NOTE:** The lower blade guard must be raised to the upright position to access the cover plate screw.
- Lower the blade guard (1), and verify that the operation of the guard does not bind or stick. (Fig. H)
- Be sure the arbor lock is released so the blade turns freely.

### **▲ WARNING**

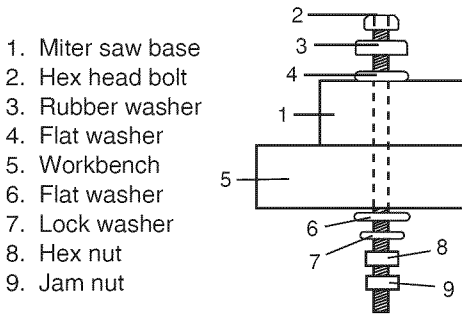
- To avoid injury, never use the saw without the cover plate secured in place. It keeps the arbor bolt from falling out if it accidentally loosens and helps prevent the spinning blade from coming off the saw.**
- Make sure the collars are clean and properly arranged. Lower the blade into the lower table, and check for any contact with the metal base or the miter table.**
- To avoid injury from an accidental start, make sure the switch is in the off position, and the plug is not connected to the power source.**

## MOUNTING THE MITER SAW (FIG. L, M)

### Mounting instructions

1. **For stationary use**, place the saw in the desired location, directly on a workbench where there is room for handling and proper support of the workpiece. The base of the saw has four mounting holes. Bolt the base of the miter saw (1) to the work surface (5), using the fastening method shown in Fig. L.

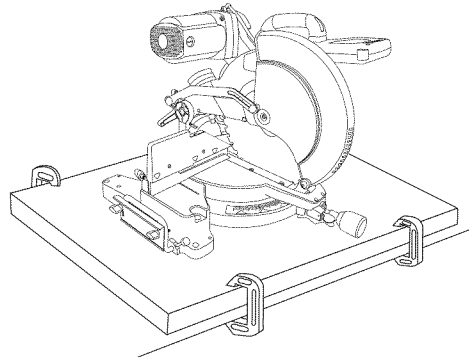
**Fig. L**



**NOTE:** Mounting hardware is not included with this tool. Bolts, nuts, washers, and screws must be purchased separately.

2. **For portable use**, place the saw on a 3/4 in. thick piece of plywood. Bolt the base of the miter saw securely to the plywood using the mounting holes on the base. Use C-clamps to clamp this mounting board to a stable work surface at the worksite. (Fig. M)

**Fig. M**



# ADJUSTMENTS

## BEVEL STOP ADJUSTMENT

### **⚠ WARNING**

To avoid injury from an accidental start, make sure the switch is in the OFF position and the plug is not connected to the power source outlet.

### 90° Bevel adjustment (Fig. N, O)

1. Loosen bevel lock handle (1), and tilt the cutting arm completely to the right. Tighten the bevel lock handle. Lower blade.
2. Place a combination square (2) on the miter table with the rule against the table and the heel of the square against the saw blade.
3. If the blade is not 90° (0°) square with the miter table, loosen the bevel lock handle (1), tilt the cutting head completely to the left, loosen the lock nut (3) on the bevel angle adjustment bolt (4) and adjust the bolt (4) in or out to increase or decrease the bevel angle with a 10 mm wrench.
4. Tilt the cutting arm to back to the right at 90° (0°) bevel and recheck for alignment.
5. Repeat steps 1 through 4 if further adjustment is needed.
6. Tighten the bevel lock handle (1) and lock nut (3) when alignment is achieved.

Fig. N

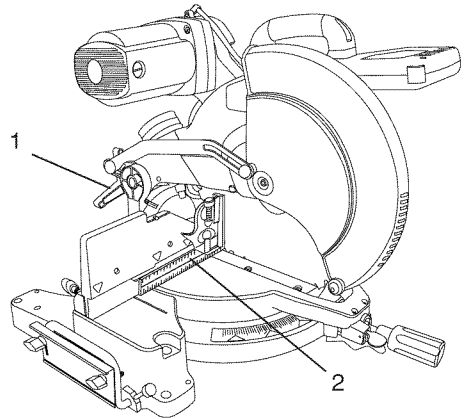
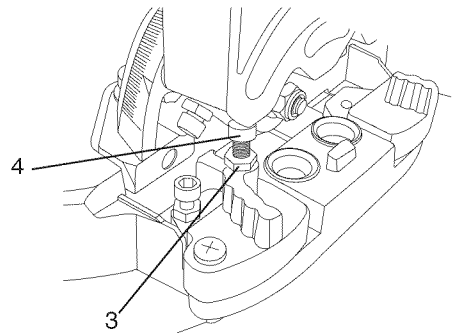


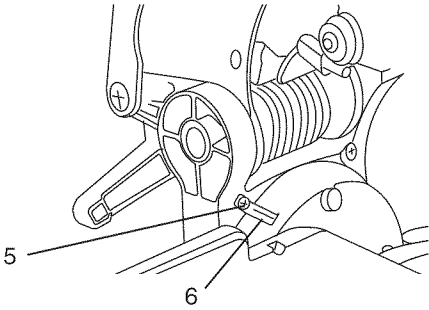
Fig. O



### 90° Bevel Pointer Adjustment (Fig. P)

1. When the blade is exactly 90° (0°) to the table, loosen the bevel indicator screws (5) using a star-head screwdriver.
2. Adjust bevel indicators (6) to the "0" mark on the bevel scale and retighten the screw.

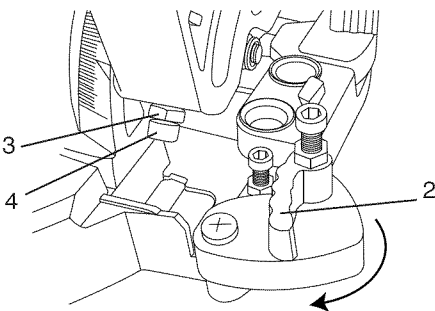
**Fig. P**



**45° Right Bevel Positive Stop Adjustment (Fig. Q)**

1. Loosen the bevel lock handle (1) and set saw arm at 45° angle.
2. Set the stop block at 45° position by turning the lever (2) clockwise.
3. Tilt the cutting arm completely to the right.
4. Using a combination square, check to see if the blade is 45° to the table.
5. If the blade is not 45° to the miter table, tilt the cutting arm to the left, loosen the locknut (3), and turn the bolt (4) in or out to increase or decrease the angle.
6. Tilt the cutting arm back to the right, and recheck alignment.
7. Repeat steps until the blade is 45° to the table. Once alignment is achieved, tighten the locknut (3) to secure the positive stop bolt.

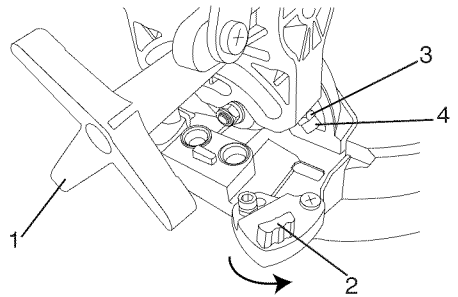
**Fig. Q**



**45° Left Bevel Positive Stop Adjustment (Fig. R)**

1. Loosen the bevel lock handle (1) and set saw arm at 45° angle.
2. Set the stop block at 45° position by turning the lever (2) counterclockwise.
3. Tilt the cutting arm completely to the left.
4. Using a combination square, check to see if the blade is 45° to the table.
5. If the blade is not 45° to the miter table, tilt the cutting arm to the right, loosen the locknut (3), and turn the bolt (4) in or out to increase or decrease the angle.
6. Tilt the cutting arm back to the left, and recheck alignment.
7. Repeat steps until the blade is 45° to the table. Once alignment is achieved, tighten the locknut (3) to secure the positive stop bolt.

**Fig. R**

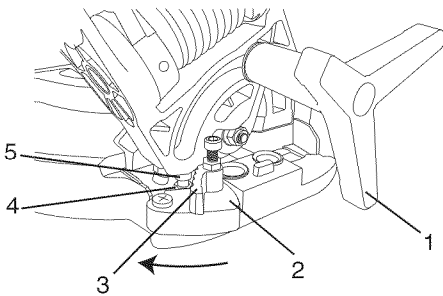




### 33.9° Right Bevel Adjustment (Fig. S)

1. Set the miter angle to 0°. Fully extend both sliding fences.
2. Loosen the bevel lock handle (1).
3. Set the stop block (2) at 33.9° position by turning the lever (3) clockwise.
4. Using a combination square, check to see if the blade is 33.9° to the table.
5. If the blade is not 33.9° to the miter table, tilt the cutting arm to the left, loosen the locknut (4) on the stop block (2), and turn the bolt (5) in or out with a hex wrench until the blade is 33.9° to the table.

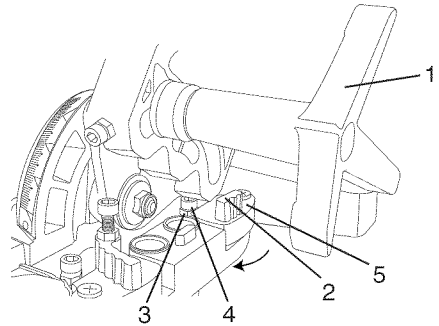
Fig. S



### 33.9° Left Bevel Adjustment (Fig. T)

1. Set the miter angle to 0°. Fully extend both sliding fences.
2. Loosen the bevel lock handle (1).
3. Set the stop block at 33.9° position by turning the lever (2) clockwise.
4. Using a combination square, check to see if the blade is 33.9° to the table.
5. If the blade is not 33.9° to the miter table, tilt the cutting arm to the right, loosen the locknut (3) on the stop block (5), and turn the bolt (4) in or out with a hex wrench until the blade is 33.9° to the table.

Fig. T



### ⚠ WARNING

To avoid injury from unexpected saw movement:

Before moving the saw, disconnect the power cord from the outlet and lock the cutting arm in the lower position using the stop latch.

NOTE: The stop latch is for carrying or storing the tool. It is NOT to be used for holding the saw while cutting.

- Never carry the miter saw by the power cord or by the switch handle. Carrying the tool by the power cord could cause damage to the insulation or wire connections, resulting in electric shock or fire.
- To avoid injury from flying debris, do not allow visitors to stand behind the saw.
- Place the saw on a firm, level work surface where there is room for handling and proper support for the workpiece.
- Support the saw on a level work surface.
- Bolt or clamp the saw to its support.

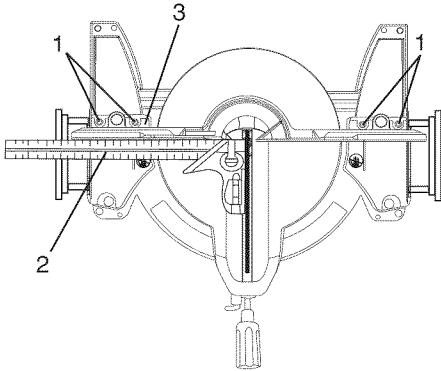
## SQUARING THE FENCE (FIG. U)

1. Loosen the four fence locking bolts (1).
2. Lower the cutting arm and lock in position.
3. Using a square (2), lay the heel of the square against the blade and the ruler against the fence (3) as shown.
4. Adjust the fence 90° to the blade and tighten the four fence locking bolts.

**CAUTION:** If the saw has not been used recently, recheck to make sure blade is square to the fence and readjust if needed.

5. After fence has been aligned, using a scrap piece of wood, make a cut at 90° then check squareness on the piece. Readjust if necessary.

Fig. U



## MITER ANGLE ADJUSTMENT (FIG. V, W)

The miter saw scale can be easily read showing miter angles from 0° to 45° to the left, and right. The most common angle cut setting slots have positive stops, permitting fast adjustments to the desired position. Follow the process below for quickest and most accurate adjustments.

1. Lift up on the miter quick lock lever (1) to unlock the table.

2. Move the turntable while lifting up on the positive stop locking lever (2) to align the indicator (3-Fig. U) to the desired degree measurement.
3. Lock the table into position by pressing down on the miter quick lock.

Fig. V

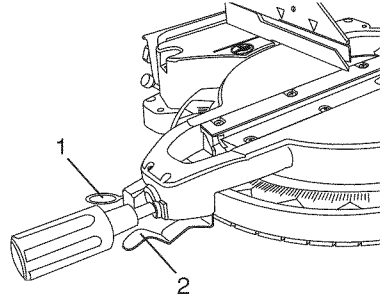
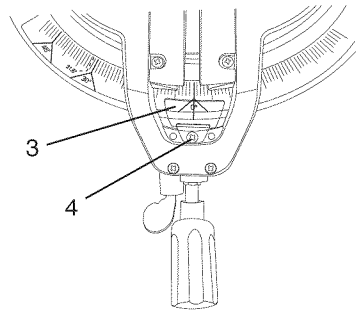


Fig. W



## MITER SCALE INDICATOR (FIG. W)

1. Move the table to the 0° positive stop.
2. Use a screwdriver to loosen the screw (4) that holds the indicator.
3. Adjust the indicator (3) to the 0° mark, and retighten.

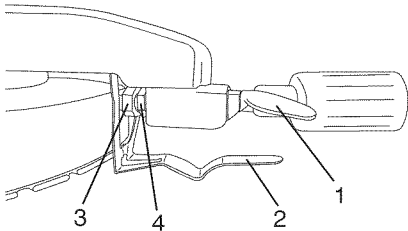
## POSITIVE STOP MITER ANGLE ADJUSTMENT (FIG. X)

1. Unlock the miter table by lifting up on the quick-cam miter locking lever (1).
2. While raising the positive stop locking lever (2) up, grasp the miter handle and rotate the miter table left or right to the desired angle.
3. Release the positive stop locking lever, and set the miter at the desired angle, making sure the lever snaps into place.

**NOTE:** The lever will only lock into place at one of the nine positive stops.

4. Once angle has been obtained, press down on the quick-cam miter locking lever (1).

**Fig. X**



4. Press down on the quick-cam miter locking lever (1) until it locks the miter table in place.

**NOTE:** The quick-cam miter locking lever should lock the table and prevent it from moving. If adjustment is needed, see next step.

## QUICK-CAM MITER TABLE LOCK ADJUSTMENT (FIG. X)

1. Press down and lock the quick-cam miter table lock.
2. Turn the stop nut (3) to the left, as shown, using a 1/2 in. wrench to extend the locking arm against the base of the miter saw.
3. Test the quick-cam miter table lock to verify it locks the table into position securely.
4. Turn the lock nut (4) to the right, as shown, to lock the miter locking mechanism into place.

## QUICK-CAM MITER TABLE LOCK OPERATION (FIG. X)

If miter angles required are NOT one of the nine positive stops noted above, the miter table can be locked at any angle between these positive stops by using the miter quick-cam table lock.

1. Unlock the miter table by lifting up on the quick-cam miter locking lever (1).
2. While holding the positive stop locking lever up, grasp the miter handle and move the miter table left or right to the desired angle.
3. Release the positive stop locking lever (2).

# OPERATION

## SAFETY INSTRUCTIONS FOR BASIC SAW OPERATIONS

### BEFORE USING THE MITER SAW

#### **WARNING**

To avoid mistakes that could cause serious, permanent injury, do not plug the tool in until the following steps are completed:

- Completely assemble and adjust the saw, following the instructions. **(SEE ASSEMBLY AND ADJUSTMENTS SECTIONS)**
- Learn the use and function of the ON/OFF switch, upper and lower blade guards, stop latch, bevel lock handle and cover plate screws.
- Review and understand all safety instructions and operating procedures in this Operator's Manual. **(SEE SAFETY AND OPERATIONS SECTIONS)**
- Review the **MAINTENANCE AND TROUBLESHOOTING GUIDE** for your miter saw.
- To avoid injury or possible death from electrical shock, make sure your fingers do not touch the plug's metal prongs when plugging in or unplugging your miter saw. **(SEE ELECTRICAL REQUIREMENTS AND SAFETY SECTIONS)**

### BEFORE EACH USE

Inspect your saw.

- **Disconnect the miter saw.**  
To avoid injury from accidental starting, unplug the saw before any adjustments, including setup and blade changes.
- **Compare the direction of rotation arrow** on the guard to the direction arrow on the blade. The blade teeth should always point downward at the front of the saw.

- **Tighten the arbor bolt.**
- **Tighten the cover plate screw.**
- **Check for damaged parts**, check for:
  - Alignment of moving parts
  - Damaged blade teeth
  - Damaged electric cords
  - Binding of moving parts
  - Mounting holes
  - Function of arm return spring and lower blade guard: Push the cutting arm all the way down, and then let it rise until it stops. The lower guard should close fully. If it does not, contact Sears Service for blade guard repair.
  - Other conditions that may affect the way the miter saw works.
- Keep all guards in place, in working order and properly adjusted. If any part of this miter saw is missing, damaged or broken, or any electrical parts do not work, turn off the saw and unplug it.
- Replace bent, damaged, missing or defective parts before using the saw again.
- Maintain tools with care. Keep the miter saw clean for best and safest performance. Follow instructions for lubricating. Do not apply lubricants to the blade while it is spinning.
- Remove all adjusting wrenches from the tool before turning it on.
- To avoid injury from jams, slips, or thrown pieces, use only recommended accessories.

### RECOMMENDED ACCESSORIES

- Consult the **ACCESSORIES** and **ATTACHMENTS** section of this Operator's Manual for recommended accessories. Follow the instructions that come with the accessory. The use of improper

accessories may cause risk of injury.

- Choose the correct 12 in. blade for the material and the type of cutting you plan to do.
- Make sure the blade is sharp, undamaged and properly aligned. With the saw unplugged, push the cutting arm all the way down. Manually spin the blade and check for clearance. Tilt the miter head to a 45° bevel and repeat the test.
- Make sure the blade and arbor collars are clean.
- Make sure all clamps and locks are tight and there is no excessive play in any parts.

### KEEP YOUR WORK AREA CLEAN

Cluttered areas and benches invite accidents.

### **⚠ WARNING**

**To avoid burns or other fire damage, never use the miter saw near flammable liquids, vapors or gases.**

- Plan ahead to protect your eyes, hands, face and ears.
- Know your miter saw. Read and understand the Operator's Manual and labels affixed to the tool. Learn its application and limitations as well as the potential hazards specific to this tool. To avoid injury from accidental contact with moving parts, do not lay out, assemble or set up work on the miter saw.
- Avoid accidental starting. Make sure the switch is in the OFF position before plugging the miter saw into a power outlet.

### PLAN YOUR WORK

Use the right tool. Do not force a tool or attachment to do a job it was not designed to do. Use a different tool for any workpiece that cannot be held in a solidly braced, fixed position.

### **⚠ WARNING**

**This machine is NOT designed for cutting masonry, masonry products or ferrous metals (steel, iron and iron-based metals.) Use this miter saw to cut only wood and wood by-products. Other materials may shatter, bind the blade or create other dangers. Remove all nails that may be in the workpiece to prevent sparking that could cause a fire.**

### DRESS FOR SAFETY



Any power tool can throw debris into the eyes. This can result in permanent eye damage.

Everyday eyeglasses have only impact resistant lenses and are not safety glasses. Glasses or goggles not in compliance with ANSI Z87.1 could seriously injure you when they break.

- Do not wear loose clothing, gloves, neckties or jewelry (rings, watches). They can get caught and draw you into moving parts.
- Wear non-slip footwear.
- Tie back long hair.
- Roll long sleeves above the elbow.
- Noise levels vary widely. To avoid possible hearing damage, wear hearing protection when using any miter saw.
- For dusty operations, wear a dust mask along with safety goggles.

### INSPECT YOUR WORKPIECE

- Make sure there are no nails or foreign objects in the part of the workpiece being cut.
- Plan your work to avoid small pieces that may bind or are too small to clamp and hold securely.
- Plan the way you will grasp the workpiece from start to finish. Avoid awkward operations and hand positions. A sudden slip could cause your fingers or hand to move into the blade.

## DO NOT OVERREACH

Keep good footing and balance. Keep your face and body to one side, out of the line of a possible kickback. NEVER stand in the line of the blade. NEVER reach your arm or hand across the cutting path of the blade.

### Never cut freehand:

- Brace your workpiece firmly against the fence and table stop so it will not rock or twist during the cut.
- Make sure there is no debris between the workpiece and the table or fence.
- Make sure there are no gaps between the workpiece, fence and table that will let the workpiece shift after it is cut.
- Keep the cut piece free to move sideways after it is cut off. Otherwise, it could get wedged against the blade and thrown violently.
- Only the workpiece should be on the saw's table.
- Secure work. Use clamps or a vise to help hold the work when it is practical.

## USE EXTRA CAUTION WITH LARGE OR ODD SHAPED WORKPIECES

- Use extra supports (tables, sawhorses, blocks, etc.) for workpieces large enough to tip.
- Never use another person as a substitute for a table extension or as an additional support for a workpiece that is longer or wider than the basic miter saw table, or to help feed, support or pull the workpiece.
- Do not use this saw to cut small pieces. If the workpiece being cut would cause your hand or fingers to be within 8-3/25 in. of the saw blade, the workpiece is too small. Keep hands and fingers out of the "no-hands zone" area marked on the saw's table.

- When cutting odd shaped workpieces, plan your work so it will not bind in the blade and cause injury. Molding, for example, must lie flat or be held by a fixture or jig that will not let it move when cut.
- Properly support round material such as dowel rods or tubing, which have a tendency to roll when cut, causing the blade to "bite."

### **WARNING**

#### **To avoid injury, follow all applicable safety instructions when cutting non-ferrous metals:**

- Use only saw blades specifically recommended for non-ferrous metal cutting.
- Do not cut metal workpieces that must be hand held. Clamp workpieces securely.
- Cut non-ferrous metals only if you are under the supervision of an experienced person and the dust bag has been removed from the saw.

## WHEN SAW IS RUNNING

### **WARNING**

**Do not allow familiarity from frequent use of your miter saw to result in a careless mistake. A careless fraction of a second is enough to cause a severe injury.**

**Before cutting, if the saw makes an unfamiliar noise or vibrates, stop immediately. Turn the saw OFF. Unplug the saw. Do not restart until you find and correct the problem.**

## BODY AND HAND POSITION (FIG. Y)



Never place hands near the cutting area. Proper positioning of your body and hands when operating the miter saw will make cutting easier and safer. Keep children away. Keep all visitors at a safe distance from the miter saw. Make sure bystanders are clear of the saw and workpiece. Do not force the saw. It will do the job better and safer at its designed rate.

### Starting a cut:

- Place hands at least 8-3/25 in. away from the path of the blade - out of the “no-hands zone”.
- Hold workpiece firmly against the fence to prevent movement toward the blade.
- With the power switch OFF, bring the saw blade down to the workpiece to see the cutting path of the blade.
- Squeeze trigger switch to start saw.
- Lower blade into workpiece with a firm downward motion.

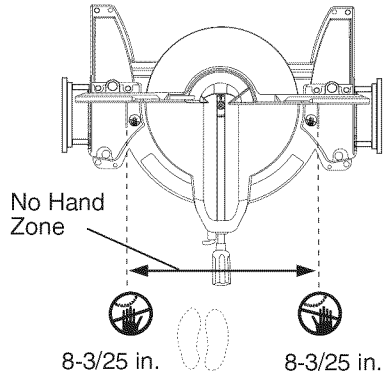
### Finishing a cut:

- Hold the cutting arm in the down position.
- Release trigger switch and wait for all moving parts to stop before moving your hands and raising the cutting arm.
- If the blade doesn't stop within 10 seconds, unplug the saw and follow the instructions in TROUBLESHOOTING GUIDE - MOTOR section.

### Before freeing jammed material:

- Release trigger switch.
- Wait for all moving parts to stop.
- Unplug the miter saw.

Fig. Y



## BASIC SAW OPERATIONS

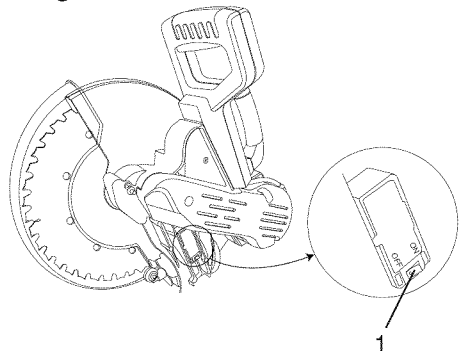
### ▲ WARNING

For your convenience, your saw has a blade brake. The brake is not a safety device. Never rely on it to replace the proper use of the guard on your saw. If the blade doesn't stop within approximately 10 seconds, wait for the blade to stop, unplug the saw and contact the Customer Help Line at 800-843-1682.

## THE LASER TRAC® GUIDE (FIG. Z, Z-1)

1. To turn laser on, turn switch (1) to “I” position.
2. To turn laser off, turn switch to “O” position.

Fig. Z

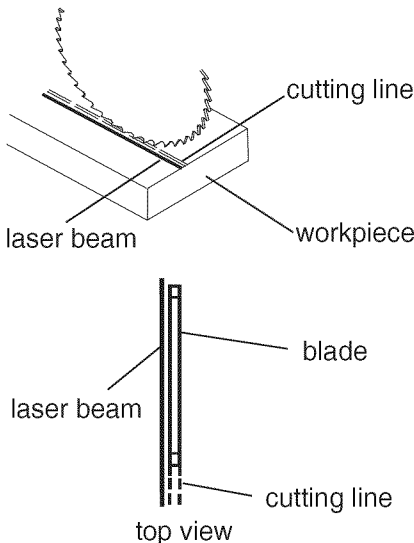


Your tool is equipped with the Laser Trac® cutting guide using a Class IIIa laser beam. The laser beam allows you to preview the saw blade path on the stock to be cut before starting the miter saw. This laser guide is powered by the transformed alternating current supply directly through the power lead. **The saw must be connected to the power source and the laser on/off switch must be turned on for the laser line to show.**

**NOTE:**

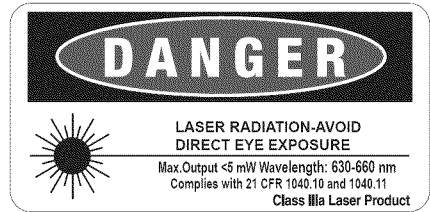
- All the adjustments for the operation of the laser guide has been completed at the factory.
- Laser beam is calibrated and set up to project to the left of the blade. (Fig. Z-1)
- If you have any problem or question on the laser guide, please contact the Customer Help Line at 800-843-1682.

**Fig. Z-1**



**⚠ WARNING**

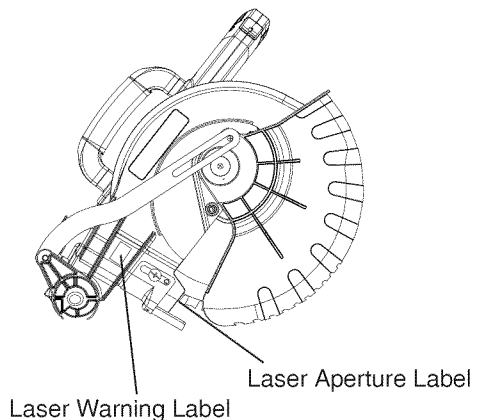
- **AVOID DIRECT EYE CONTACT**  
Laser radiated when laser guide is turned on. Avoid direct eye contact.
- **Laser Warning Label:**  
Maximum output < 5 mW,  
Wavelength: 630-660 nm,  
Complies with 21CFR 1040.10 and 1040.11 Class IIIa Laser Product. (Fig. Z-2)



- **Laser Aperture Label:**  
**AVOID EXPOSURE:** Laser radiation is emitted from this aperture. (Fig. Z-2)



**Fig. Z-2**





- **CAUTION-Use of controls or performance of procedures other than those specified herein may result in hazardous radiation exposure.**
- **CAUTION-The use of optical instruments with this product will increase eye hazard.**
- **Do not attempt to repair or disassemble the laser. If unqualified persons attempt to repair this laser product, serious injury may result. Any repair required on this laser product should be performed by a Sears or other qualified service dealer.**

### TO TURN SAW ON (FIG. AA)

To reduce the likelihood of accidental starting, a lock-off switch (3) is located on top of the switch handle. The lock-off switch (3) must be pressed forward before the trigger switch (1) can be activated and the miter saw started.

This miter saw is equipped with an ON/OFF trigger switch (1). The trigger switch should be squeezed to turn the miter saw ON.

**NOTE:** Make the ON/OFF switch childproof. Insert a padlock or chain with a padlock through the hole (2) in the trigger switch, locking the tool's switch and preventing children and other unauthorized users from turning the machine on.

The miter saw is equipped with an automatic blade brake. When the trigger switch is released, the electric blade brake will stop the blade in 10 seconds.

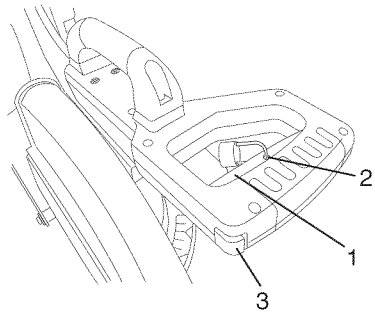
### **▲ WARNING**

To avoid injury, after completing a cut and releasing the trigger switch, allow the blade brake to activate and stop the blade before raising the cutting head.

### **▲ WARNING**

To avoid injury, check and tighten the arbor bolt periodically.

Fig. AA

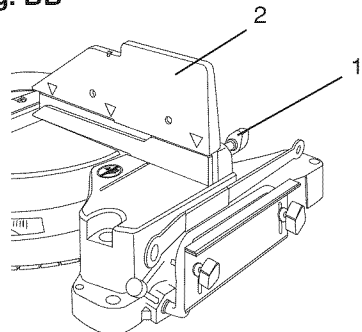


### SLIDING FENCE (FIG. BB)

1. Unlock the fence cam locking knob (1) by pushing it toward the rear of the machine.
2. Extend the fence (2) by sliding it out to match the degree of the bevel cut. Lock the fence cam locking lever by pushing it IN toward the fence.

**NOTE:** When transporting the saw, always secure the sliding fence in the collapsed position (toward the saw blade).

Fig. BB



## BEFORE LEAVING THE SAW

- Never leave tool running unattended. Turn power OFF. Wait for all moving parts to stop.
- Make workshop childproof. Lock the shop. Disconnect master switches. Store tool away from children and other unqualified users.

## WARNING

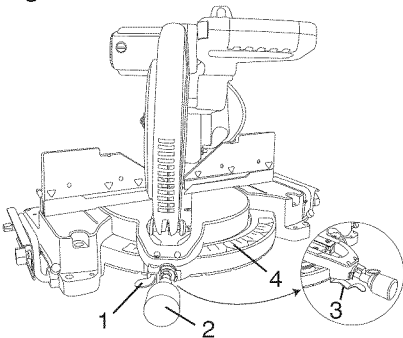
To avoid injury from materials being thrown, always unplug the saw to avoid accidental starting, and remove small pieces of material from the table cavity.

## MITER CUT (FIG. CC)

1. When a miter cut is required, unlock the miter table by releasing the miter lock lever (1).
2. While holding the miter handle (2), press down on the positive stop locking lever (3).
3. Rotate the miter table to the right or left with the miter handle.
4. When the table is in the desired position, as shown on the miter scale (4), release the positive stop locking lever and tighten the miter handle. The table is now locked at the desired angle. Positive stops are provided at 0°, 15°, 22.5°, 31.6° and 45°.

**IMPORTANT:** Always lock the miter lock lever before performing a cut.

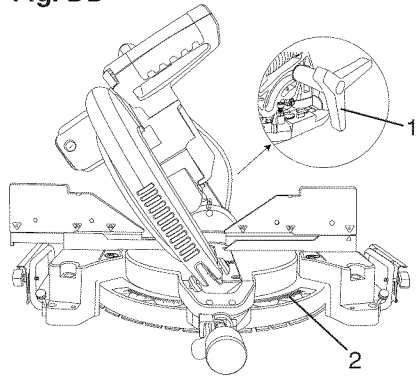
Fig. CC



## BEVEL CUT (FIG. DD)

1. When a bevel cut is required, loosen the bevel lock handle (1) by turning it clockwise.
2. Tilt the cutting head to the desired angle, as shown on the bevel scale (2).
3. The blade can be positioned at any angle, from a 90° straight cut (0° on the scale) to a 45° left/right bevel. Tighten the lock handle (1) to lock the cutting head in position. Positive bevel stops are provided at 0° and 45°.

Fig. DD

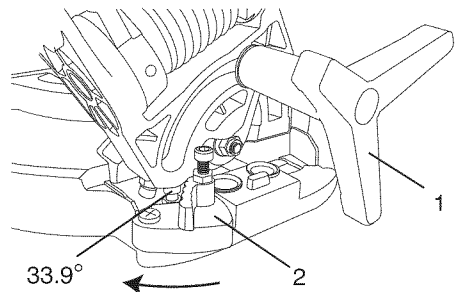


## 33.9° CROWN MOULDING (FIG. EE)

**NOTE:** When cutting crown moulding, the bevel angle should be set 33.9° right or left.

1. Loosen the bevel lock handle (1),
2. Rotate the bevel stop block (2) and set bevel angle at the 33.9° position.
3. Tilt the cutting arm to the left or right.

Fig. EE



## **▲ WARNING**

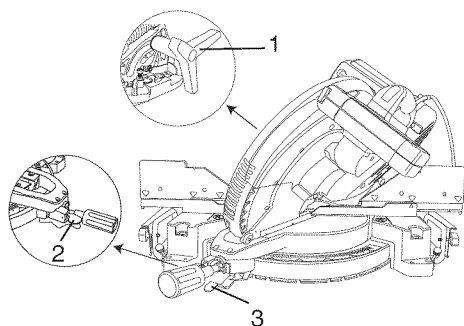
The sliding fence must be extended to the left when making bevel cuts. The sliding fence has been notched three bevel angles where the user must adjust the fence to match the degree of the bevel cut. Failure to extend the sliding fence will not allow enough space for the blade to pass through which could result in serious injury. At extreme miter or bevel angles the saw blade may also come in contact with the fence.

### **COMPOUND CUT (FIG. FF)**

A compound cut is the combination of a miter and a bevel cut simultaneously.

1. Extend the sliding fence as described in "SLIDING FENCE".
2. Loosen the bevel lock handle (1) and position the cutting head at the desired bevel position. Lock the bevel lock handle.
3. Release miter lock lever (2). Press down the positive stop locking lever (3) and position the table at the desired angle. Release the positive stop locking lever and lock the miter lock lever.

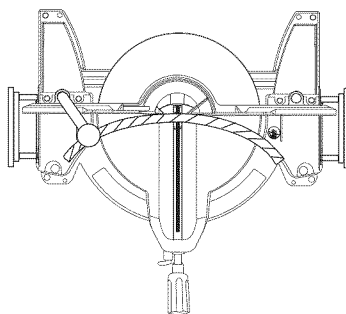
**Fig. FF**



### **CUTTING BOWED MATERIAL (FIG. GG)**

A bowed workpiece must be positioned against the fence and secured with a clamping device before cutting. Do not position workpiece incorrectly or try to cut the workpiece without the support of the fence. This will cause the blade to bind, and could result in personal injury.

**Fig. GG**

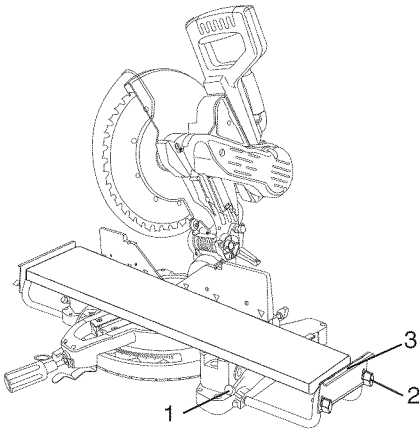


### **WORKPIECE SUPPORT AND REPETITIVE CUTTING USING THE STOP PLATE (FIG. HH)**

Long pieces need extension table support.

1. Loosen the knob (1), and then slide the extension wing to desired position and tighten the knob.
2. The arm bracket is designed for use during repetitive cutting. Only use one stop plate at a time. Loosen the locking knobs (2), raise the arm bracket (3), and retighten the locking knobs.

**Fig. HH**



**AUXILIARY WOOD FENCE (FIG. II)**

When making multiple or repetitive cuts that result in cut-off pieces of one inch or less, it is possible for the saw blade to catch the cut-off piece and throw it out of the saw or into the blade guard and housing, possibly causing damage or injury. To minimize this possibility, an auxiliary wood fence can be mounted to your saw.

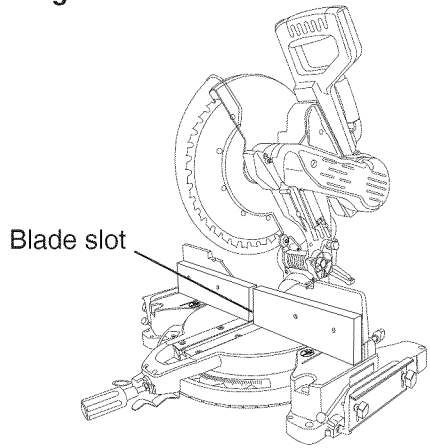
Holes are provided in the saw fence to attach an auxiliary wood fence. This fence should be constructed of straight auxiliary wood.

Attach the wood fence securely, and make a full-depth cut to make a blade slot.

Check for interference between the wood fence and the lower blade guard. Adjust if necessary.

**NOTE:** This auxiliary fence is used only with the saw blade in the 0° bevel position (90° to the table). The auxiliary wood fence must be removed when bevel cutting.

**Fig. II**



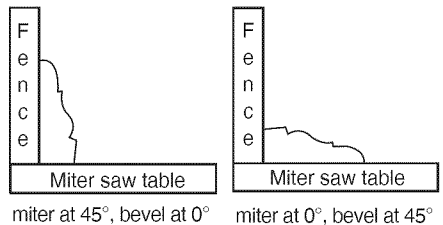
**CUTTING BASE MOULDING (FIG. JJ)**

Base mouldings and trims can be cut on a compound miter saw. The method depends on the type of moulding, its characteristics and applications.

1. Use vise clamps, hold-down or C-clamps whenever possible. Place tape on the area being clamped to avoid marking the finish surface of the moulding.
2. Tape the area being cut to avoid splintering, and mark the cut line on the tape.
3. Perform practice cuts on scrap pieces before cutting the final moulding.

**NOTE:** Splintering may be caused due to the thinness of the moulding or use of the wrong type of blade.

**Fig. JJ**



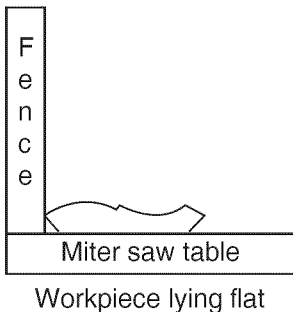
## CUTTING CROWN MOULDING (FIG. KK, LL)

Crown moulding must be compound mitered with extreme accuracy. The two surfaces on the crown moulding must fit the wall or ceiling, and each other.

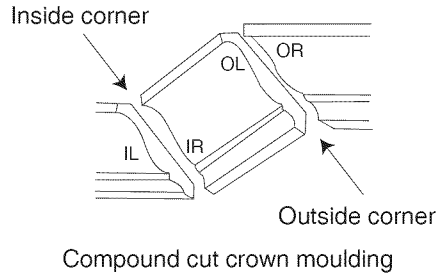
The two cut surfaces of the mitered moulding must add to a 90° angle. Most crown moulding has a top angle of 52° that fits flat on the ceiling, and a bottom rear angle of 38° that fits flat against the wall.

1. If the crown moulding is thin and cannot stand vertically on edge, lay the moulding flat with its widest back surface flat on the saw table. (Fig. KK)
2. To avoid splintering and marking, tape the cutting line and any surface that is being clamped.
3. The angle settings for the two pieces of moulding that will be adjoining in any one corner, will be interdependent with each other. Any change in the setting for one side must be equally compensated for on the other side.
4. All settings should be tested on scrap material before cutting the actual moulding.

**Fig. KK**



**Fig. LL**



### Bevel/Miter Settings

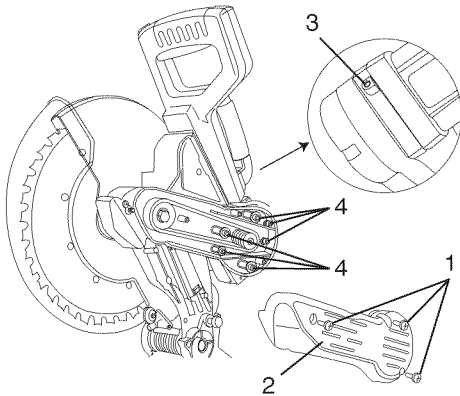
**NOTE:** The chart below references a compound cut for crown moulding **ONLY WHEN THE ANGLE BETWEEN THE WALLS EQUALS EXACTLY 90°.**

KEY	BEVEL SETTING	MITER SETTING	TYPE OF CUT
<b>Inside corner-Left side</b>			
IL	33.9°	31.6° Right	1. Position top of molding against fence. 2. Miter table set at RIGHT 31.6°. 3. LEFT side is finished piece.
<b>Inside corner-Right side</b>			
IR	33.9°	31.6° Left	1. Position bottom of molding against fence. 2. Miter table set at LEFT 31.6°. 3. LEFT side is finished piece.
<b>Outside corner-Left side</b>			
OL	33.9°	31.6° Left	1. Position bottom of molding against fence. 2. Miter table set at LEFT 31.6°. 3. RIGHT side is finished piece.
<b>Outside corner-Right side</b>			
OR	33.9°	31.6° Right	1. Position top of molding against fence. 2. Miter table set at RIGHT 31.6°. 3. RIGHT side is finished piece.

## CHANGING THE BELT (FIG. MM)

- Unplug your saw.
1. Loosen the three bolts (1) and remove the belt cover (2).
  2. Loosen the set screw (3) with a 4 mm hex key and six hex screws (4) with a 5 mm hex key counterclockwise to move the motor forward.
  3. Remove and replace the belt.
  4. Lift the motor housing up and retighten the set screw (3).
  5. Retighten the hex screws (4) clockwise. Do not overtighten.
  6. Replace the belt cover and tighten all bolts.

**Fig. MM**



# CROWN MOLDING CHART

## Compound Miter Saw Miter and Bevel Angle Settings Wall to Crown Molding Angle

Angle Between Walls	52/38° Crown Molding		45/45° Crown Molding	
	Miter Setting	Bevel Setting	Miter Setting	Bevel Setting
67	42.93	41.08	46.89	36.13
68	42.39	40.79	46.35	35.89
69	41.85	40.50	45.81	35.64
70	41.32	40.20	45.28	35.40
71	40.79	39.90	44.75	35.15
72	40.28	39.61	44.22	34.89
73	39.76	39.30	43.70	34.64
74	39.25	39.00	43.18	35.38
75	38.74	38.69	42.66	34.12
76	38.24	38.39	42.15	33.86
77	37.74	38.08	41.64	33.60
78	37.24	37.76	41.13	33.33
79	36.75	37.45	40.62	33.07
80	36.27	37.13	40.12	32.80
81	35.79	36.81	39.62	32.53
82	35.31	36.49	39.13	32.25
83	34.83	36.17	38.63	31.98
84	34.36	35.85	38.14	31.70
85	33.90	35.52	37.66	31.42
86	33.43	35.19	37.17	31.14
87	32.97	34.86	36.69	30.86
88	32.52	34.53	36.21	30.57
89	32.07	34.20	35.74	30.29
90	31.62	33.86	35.26	30.00
91	31.17	33.53	34.79	29.71
92	30.73	33.19	34.33	29.42
93	30.30	32.86	33.86	29.13
94	29.86	32.51	33.40	28.83
95	29.43	32.17	32.94	28.54
96	29.00	31.82	32.48	28.24
97	28.58	31.48	32.02	27.94
98	28.16	31.13	31.58	27.64
99	27.74	30.78	31.13	27.34
100	27.32	30.43	30.68	27.03
101	26.91	30.08	30.24	26.73
102	26.50	29.73	29.80	26.42
103	26.09	29.38	29.36	26.12
104	25.69	29.02	28.92	25.81
105	25.29	28.67	28.48	25.50
106	24.89	28.31	28.05	25.19
107	24.49	27.96	27.62	24.87
108	24.10	27.59	27.19	24.56
109	23.71	27.23	26.77	24.24
110	23.32	26.87	26.34	23.93
111	22.93	26.51	25.92	23.61
112	22.55	26.15	25.50	23.29
113	22.17	25.78	25.08	22.97
114	21.79	25.42	24.66	22.66
115	21.42	25.05	24.25	22.33
116	21.04	24.68	23.84	22.01
117	20.67	24.31	23.43	21.68
118	20.30	23.94	23.02	21.36
119	19.93	23.57	22.61	21.03
120	19.57	23.20	22.21	20.70
121	19.20	22.83	21.80	20.38
122	18.84	22.46	21.40	20.05
123	18.48	22.09	21.00	19.72

Angle Between Walls	52/38° Crown Molding		45/45° Crown Molding	
	Miter Setting	Bevel Setting	Miter Setting	Bevel Setting
124	18.13	21.71	20.61	19.39
125	17.77	21.34	20.21	19.06
126	17.42	20.96	19.81	18.72
127	17.06	20.59	19.42	18.39
128	16.71	20.21	19.03	18.06
129	16.37	19.83	18.64	17.72
130	16.02	19.45	18.25	17.39
131	15.67	19.07	17.86	17.05
132	15.33	18.69	17.48	16.71
133	14.99	18.31	17.09	16.38
134	14.66	17.93	16.71	16.04
135	14.30	17.55	16.32	15.70
136	13.97	17.17	15.94	15.36
137	13.63	16.79	15.56	15.02
138	13.30	16.40	15.19	14.62
139	12.96	16.02	14.81	14.34
140	12.63	15.64	14.43	14.00
141	12.30	15.25	14.06	13.65
142	11.97	14.87	13.68	13.31
143	11.64	14.48	13.31	12.97
144	11.31	14.09	12.94	12.62
145	10.99	13.71	12.57	12.29
146	10.66	13.32	12.20	11.93
147	10.34	12.93	11.83	11.59
148	10.01	12.54	11.46	11.24
149	9.69	12.16	11.09	10.89
150	9.37	11.77	10.73	10.55
151	9.05	11.38	10.36	10.20
152	8.73	10.99	10.00	9.85
153	8.41	10.60	9.63	9.50
154	8.09	10.21	9.27	9.15
155	7.77	9.82	8.91	8.80
156	7.46	9.43	8.55	8.45
157	7.14	9.04	8.19	8.10
158	6.82	8.65	7.83	7.75
159	6.51	8.26	7.47	7.40
160	6.20	7.86	7.11	7.05
161	5.88	7.47	6.75	6.70
162	5.57	7.08	6.39	6.35
163	5.26	6.69	6.03	6.00
164	4.95	6.30	5.68	5.65
165	4.63	5.90	5.32	5.30
166	4.32	5.51	4.96	4.94
167	4.01	5.12	4.61	4.59
168	3.70	4.72	4.25	4.24
169	3.39	4.33	3.90	3.89
170	3.08	3.94	3.54	3.53
171	2.77	3.54	3.19	3.10
172	2.47	3.15	2.83	2.83
173	2.15	2.75	2.48	2.47
174	1.85	2.36	2.12	2.12
175	1.54	1.97	1.77	1.77
176	1.23	1.58	1.41	1.41
177	0.92	1.18	1.06	1.06
178	0.62	0.79	0.71	0.71
179	0.31	0.39	0.35	0.35

# MAINTENANCE

## MAINTENANCE

### **▲ DANGER**

Never put lubricants on the blade while it is spinning.

### **▲ WARNING**

- To avoid fire or toxic reaction, never use gasoline, naphtha acetone, lacquer thinner or similar highly volatile solvents to clean the miter saw.
- To avoid injury from unexpected starting or electrical shock, unplug the power cord before working on the saw.
- For your safety, this saw is double insulated. To avoid electrical shock, fire or injury, use only parts identical to those identified in the parts list. Reassemble exactly as the original assembly to avoid electrical shock.

## REPLACING CARBON BRUSHES (FIG. NN)

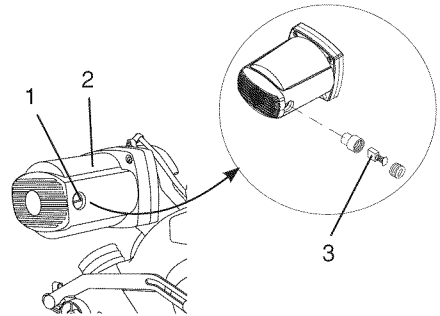
The carbon brushes (3) that are provided will last approximately 50 hours of running time, or 10,000 ON/OFF cycles. Replace carbon brushes (3) when it less than 1/4 in. of carbon remaining, or if the spring or wire is damaged or burned. To inspect or replace brushes, first unplug the saw, and then remove the black plastic cap (1) on the side of the motor (2). Remove the cap carefully, because it is spring-loaded. Then pull out the brush and replace.

To reassemble, reverse the procedure. The ears on the metal end of the assembly go in the same hole in which

the carbon part fits. Tighten the cap snugly, but do not overtighten.

**NOTE:** To reinstall the same brushes, first make sure the brushes go back in the way they came out. This will avoid a break-in period.

Fig. NN



## LOWER BLADE GUARD

Do not use the saw without the lower blade guard. The lower blade guard is attached to the saw for your protection. Should the lower guard become damaged, do not use the saw until the damaged guard has been replaced. Before each use, with the saw unplugged, check to make sure the lower guard moves smoothly when the cutting head is raised and lowered. If needed, clean any sawdust buildup with a damp cloth. Check to see if any of the link or pivot points need lubrication. If so, see lubrication instructions on page 41.

**CAUTION:** Do not use solvents on the guard. They could make the plastic “cloudy” and brittle.



## **▲ WARNING**

**When cleaning the lower guard, unplug the saw from the power source receptacle to avoid unexpected start-up.**

### **LUBRICATION (FIG. OO)**

All of the motor bearings in this tool are lubricated with a sufficient amount of high-grade lubricant for the life of the unit under normal operating conditions. Therefore, no further lubrication is required.

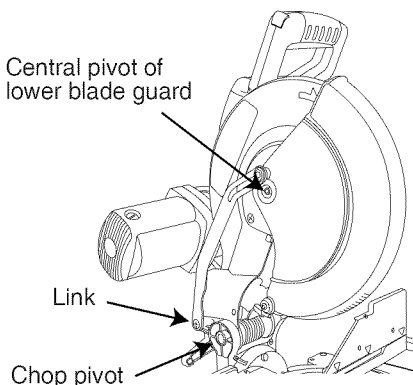
Lubricate the following as necessary:

**Chop pivot:** Apply light machine oil to points indicated in illustration.

**Central pivot of lower blade guard:** Use light household oil (sewing machine oil) on metal-to-metal or metal-to-plastic guard contact areas as required for smooth, quiet operation. Avoid excessive oil, because sawdust will cling to it.

**Link:** (actuates the lower guard movement) may be oiled at the rear pivot, greased at ball bearing contact, and oiled where the link actuates the acetyl roller of the lower guard, if the downward chop motion is hard to start.

**Fig. OO**



# TROUBLESHOOTING GUIDE

## WARNING

To avoid injury from accidental starting, always turn switch OFF and unplug the tool before moving, replacing the blade or making adjustments.

### TROUBLESHOOTING GUIDE - MOTOR

PROBLEM	PROBLEM CAUSE	SUGGESTED CORRECTIVE ACTION
Brake does not stop blade within 10 seconds.	<ol style="list-style-type: none"> <li>1. Motor brushes not sealed or lightly sticking.</li> <li>2. Motor brake overheated from use of defective or wrong size blade or rapid ON/OFF cycling.</li> <li>3. Arbor bolt loose.</li> <li>4. Brushes cracked, damaged, etc.</li> <li>5. Other.</li> </ol>	<ol style="list-style-type: none"> <li>1. Inspect/clean/replace brushes. See MAINTENANCE section.</li> <li>2. Use the blade specified in this Operator's Manual. Let cool down. See REMOVING OR INSTALLING THE BLADE section.</li> <li>3. Retighten. See REMOVING OR INSTALLING THE BLADE section.</li> <li>4. Replace brushes.</li> <li>5. Contact the Customer Help Line at 1-800-843-1682.</li> </ol>
Motor does not start	<ol style="list-style-type: none"> <li>1. Limit switch failure</li> <li>2. Brush worn.</li> <li>3. Fuse blown or circuit breaker tripped on home panel.</li> <li>4. Other.</li> </ol>	<ol style="list-style-type: none"> <li>1. Replace limit switch.</li> <li>2. Replace brushes. See MAINTENANCE section.</li> <li>3. Verify there is electrical power at the outlet.</li> <li>4. Contact Contact the Customer Help Line at 1-800-843-1682.</li> </ol>
Brush spark when switch released.	<ol style="list-style-type: none"> <li>1. Brush worn.</li> <li>2. Other.</li> </ol>	<ol style="list-style-type: none"> <li>1. Replace Brushes. See MAINTENANCE section.</li> <li>2. Contact the Customer Help Line at 1-800-843-1682.</li> </ol>

# TROUBLESHOOTING GUIDE

## WARNING

To avoid injury from accidental starting, always turn switch OFF and unplug the tool before moving, replacing the blade or making adjustments.

### TROUBLESHOOTING GUIDE - SAW OPERATION

PROBLEM	PROBLEM CAUSE	SUGGESTED CORRECTIVE ACTION
Blade hits table.	1. Misalignment.	1. See ADJUSTMENT - Cutting Arm Travel section.
Angle of cut not accurate. Can not adjust miter.	1. Miter table unlocked. 2. Sawdust under table.	1. See OPERATION - Miter Angle Adjustment section. 2. Vacuum or blow out dust. WEAR EYE PROTECTION.
Cutting arm wobbles.	1. Loose pivot points.	1. See ADJUSTMENT - Cutting Arm Travel section.
Cutting arm will not fully raise, or blade guard won't fully close.	1. Pivot spring not replaced properly after service. 2. Sawdust build-up.	1. Contact Sears Service Center. 2. See MAINTENANCE section.
Blade binds, jams, burns wood.	1. Improper operation. 2. Dull or warped blade. 3. Improper blade size. 4. Wood is moving during cut.	1. See BASIC SAW OPERATION section. 2. Replace or sharpen blade. 3. Replace with 12 in. diameter blade. 4. Use hold down clamp to secure workpiece to table.
Saw vibrates or shakes.	1. Saw blade not round / damaged / loose. 2. Arbor bolt loose.	1. Replace blade. 2. Tighten arbor bolt.

# PARTS LIST

12 IN. DUAL BEVEL COMPOUND MITER SAW

MODEL NO. 137.375640

## WARNING

When servicing use only CRAFTSMAN replacement parts. Use of any other parts may create a HAZARD or cause product damage. Any attempt to repair or replace electrical parts on this Miter Saw may create a HAZARD unless repair is done by a qualified service technician. Repair service is available at your nearest Sears Service Center.

### PARTS LIST FOR MITER SAW - PART A

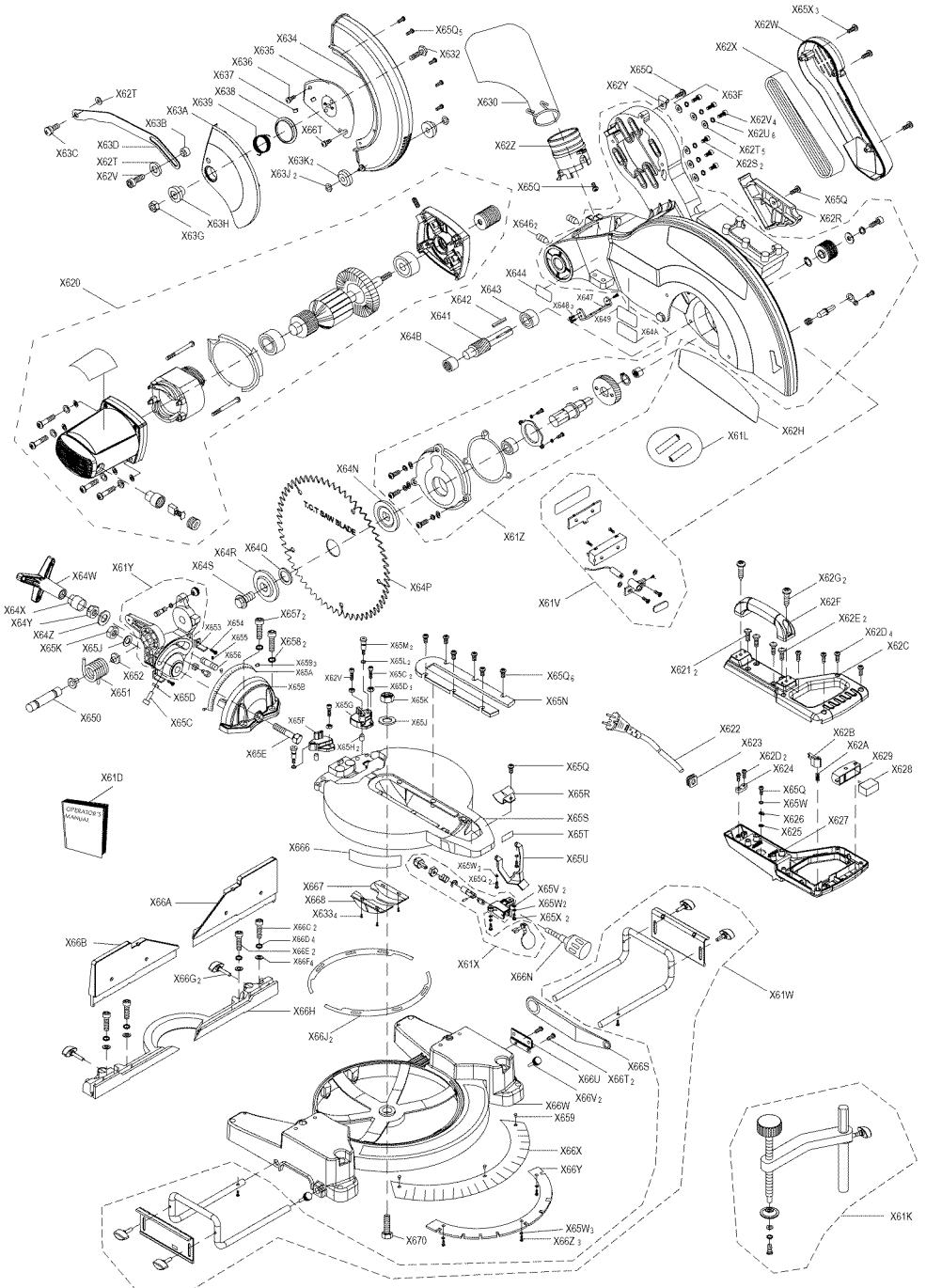
I.D.	Description	Size	Q'ty	I.D.	Description	Size	Q'ty
X670	HEX. HEAD SCREW	M8*25	1	X65S	TURNPLATE		1
X66Z	CROSS HEAD SCREW	M5*14	3	X65R	TURNPLATE POINTER		1
X66Y	TURNPLATE LOCATING PIECE		1	X65Q	CROSS HEAD SCREW	M5*10	13
X66X	BIG RULER		1	X65N	KERF BOARD		1
X66W	BASEMENT		1	X65M	STEP SPIRAL NAILS	M5	2
X66V	HAND WHEEL	M5*25	2	X65L	'O'RINGS		2
X66U	WRENCH PLATE		1	X65K	LOCK NUT	M8	2
X66T	CROSS HEAD SCREW	M6*10	3	X65J	FLAT WASHER(BIG)	§8	2
X66S	WRENCH		1	X65H	STEEL BALL INNER HEX.	M10*18	2
X66N	TURNPLATE HANDLE		1		TIGHTEN SCREW		
X66J	TURNPLATE STEEL SHEET		2	X65G	ANGULAR GAUGE BLOCK(R)		1
X66H	HORIZONTAL BAR		1	X65F	ANGULAR GAUGE BLOCK(L)		1
X66G	BUTTERFLY SCREW	M6*32	2	X65E	HEX NON-STANDARD SCREW	M8	1
X66F	FLAT WASHER	§8	4	X65D	HEX NUT	M6	4
X66E	INNER HEX. HEAD SCREW	M8*25	2	X65C	INNER HEX SCREW	M6*10	3
X66D	SPRING WASHER	§8	4	X65B	CONNECTION SEAT		1
X66C	INNER HEX. HEAD SCREW	M8*35	2	X65A	BEVEL ANGLE SCALE		1
X66B	MOVING BACKBOARD(L)		1	X659	RIVET		6
X66A	MOVING BACKBOARD(R)		1	X658	SPRING WASHER	§10	2
X668	LOWER PROTECTIVE GUARD(L)		1	X657	INNER HEX SCREW	M10*25	2
X667	LOWER PROTECTIVE GUARD(R)		1	X656	DOUBBLE HEAD SCREW	M10	1
X666	LABEL		1	X655	INNER HEX LOCKING SCREW	M6*4	1
X65X	CROSS HEAD SCREW	M5*20	5	X654	CROSS HEAD SCREW	M4*10	1
X65W	SPRING WASHER	§5	8	X653	POINTER		1
X65V	FLAT WASHER	§5	2	X652	SPRING SEAT		1
X65U	TURNPLATE LOCATING SPRING STEEL PIECE		1	X651	BIG TORSION SPRING		1
				X650	HEAD GEAR PIN		1
X65T	LABEL		1	X64Z	FLAT WASHER	§10	1

**PARTS LIST FOR MITER SAW - PART B**

I.D.	Description	Size	Q'ty	I.D.	Description	Size	Q'ty
X64Y	LOCKNUT	M10	1	X632	HEX. NON-STANDARD SCREW	M6*14	1
X64X	LOCK SLEEVE		1	X630	DUST BAG		1
X64W	BRACKET LOCK HANDLE		1	X62Z	OUTLET MOUTH		1
X64S	FLANGE LEFT HEX SREW	M8*16	1	X62Y	SMALL WIRE CLAMP		1
X64R	OUTER PRESSURE BOARD		1	X62X	BELT		1
X64Q	BLADE LOCATING RING		1	X62W	BELT COVER		1
X64P	TCT SAW BLADE		1	X62V	INNER HEX SCREW (1+4+1)	M6*20	6
X64N	INNER PRESSURE BOARD		1	X62U	SPRING WASHER	§6	6
X64B	NEEDLE BEARING HK1010		1	X62T	FLAT WASHER	§6	7
X64A	LABEL		1	X62S	INNER HEX SCREW	M6*16	2
X649	LABEL		1	X62R	COVER PLATE		1
X648	CR. RE. COUNT. HEAD SCREW	M4*8	3	X62H	LABEL		1
X647	LASER PERMANENT SEAT		1	X62G	CROSS SELF-TAPPING SCREW	ST6*18	2
X646	INNER HEX LOCKING SCREW	M6*10	2	X62F	HANDLE WRING		1
X644	LABEL		1	X62E	CROSS HEAD SCREW	M5*50	2
X643	6001 BEARING		1	X62D	CROSS SELF-TAPPING SCREW	ST3.9*14	6
X642	FLAT KEY		1	X62C	HANDLE COVER		1
X641	GEAR SHAFT		1	X62B	SELF-LOCK PUSH BUTTON SWITCH		1
X63K	TRANSPARENTMASK PROTECTION ROLLER		2	X62A	SWITCH TORSION SPRING		1
X63J	EXTERNAL PLIERS	§5	2	X629	PUSH BUTTON SWITCH		1
X63H	TRANSPARENTMASK WASHER		1	X628	SWITCH		1
X63G	LOCKNUT	M6	1	X627	HANDLE		1
X63F	FLAT WASHER	§6	1	X626	PRESS LINE BUTTON		1
X63D	CONNECTION BAR		1	X625	TEETH TYPE WASHER		1
X63C	CONNECTION NON- STANDARD STEP SCREW		1	X624	TENSION DISC		1
X63B	SPACER RING		1	X623	CABLE JACKET		1
X63A	BIG COVER PIECE		1	X622	CABLE PLUG		1
X639	TRANSPARENTMASK TORSION SPRING		1	X621	CROSS HEAD SCREW	M5*40	2
X638	TRANSPARENTMASK WASHER		1	X620	MOTOR COMPONENTS		1
X637	RUBBER BAFFLE PLATE		1	X61Z	UP AND DOWN SWING-FRAME COMPONENTS		1
X636	FLAT HEAD CROSS NON- STANDARD SCREW	M6*10	1	X61Y	ANGLE SWING-FRAME COMPONENTS		1
X635	TRANSPARENTMASK SPRING PLATE		1	X61X	RETAINER PIECE		1
X634	TRANSPARENT MASK		1	X61W	EXTENSION WING COMPONENTS		1
X633	CROSS HEAD SCREW	M5*8	4	X61V	LASER COMPONENTS		1
				X61L	AAA BATTERY		2
				X61K	CLAMP COMPONENTS		1
				X61D	OPERATOR'S MANUAL		1

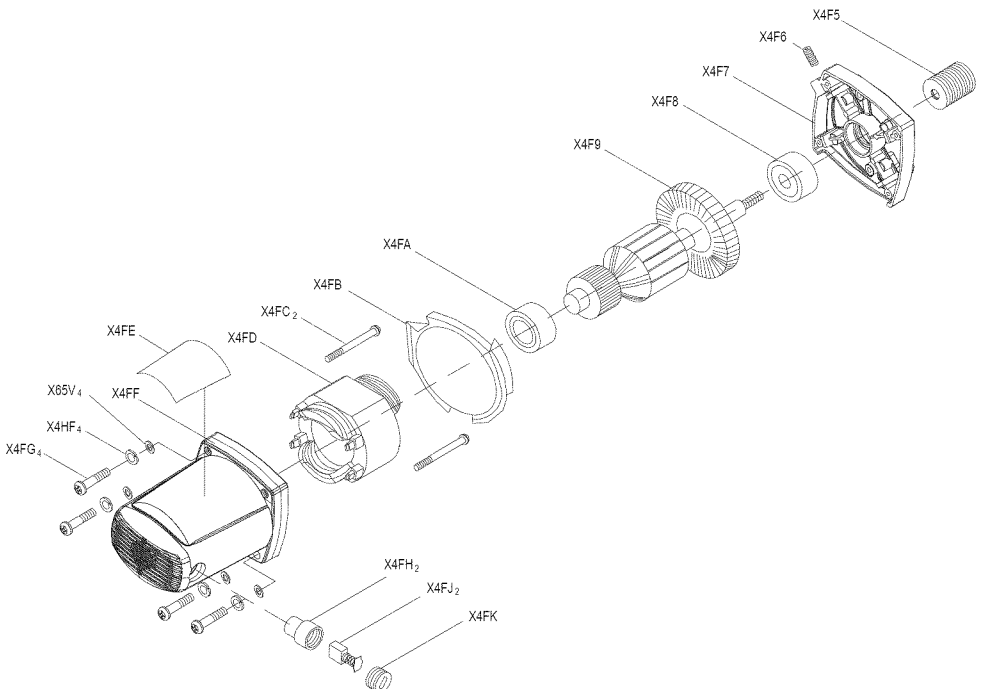
# 12 IN. DUAL BEVEL COMPOUND MITER SAW

# MODEL NO. 137.375640



**PARTS LIST AND SCHEMATIC FOR MOTOR**

I.D.	Description	Size	Q'ty
X4HF	SPRING WASHER	§5	4
X4FK	CARBON HOLD COVER		1
X4FJ	CARBON BRUSH		2
X4FH	CARBON BRUSH HOLD		2
X4FG	CROSS HEAD SCREW	M5*35	4
X4FF	MOTOR COVER		1
X4FE	MOTOR LABEL		1
X4FD	STATOR		1
X4FC	CROSS SELF-TAPPING SCREW	ST4.8*65	2
X4FB	WIND LOOP		1
X4FA	BEARING		1
X4F9	ROTOR		1
X4F8	BEARING		1
X4F7	MIDDLE COVER		1
X4F6	INNER HEX LOCKING SCREW	M8*25	1
X4F5	BELT PULLEY		1
X65V	FLAT WASHER	§5	4



# REPAIR PROTECTION AGREEMENTS

*Congratulations on making a smart purchase. Your new Craftsman® product is designed and manufactured for years of dependable operation. But like all products, it may require repair from time to time. That's when having a Repair Protection Agreement can save you money and aggravation.*

## **Here's what the Repair Protection Agreement\* includes:**

- ☑ **Expert service** by our 10,000 professional repair specialists
- ☑ **Unlimited service and no charge** for parts and labor on all covered repairs
- ☑ **Product replacement** up to \$1500 if your covered product can't be fixed
- ☑ **Discount of 25%** from regular price of service and related installed parts not covered by the agreement; also, 25% off regular price of preventive maintenance check
- ☑ **Fast help by phone** – we call it Rapid Resolution – phone support from a Sears representative. Think of us as a “talking owner’s manual.”

Once you purchase the Repair Protection Agreement, a simple phone call is all that it takes for you to schedule service. You can call anytime day or night, or schedule a service appointment online.

The Repair Protection Agreement is a risk-free purchase. If you cancel for any reason during the product warranty period, we will provide a full refund. Or, a prorated refund anytime after the product warranty period expires. Purchase your Repair Protection Agreement today!

**Some limitations and exclusions apply. For prices and additional information in the U.S.A. call 1-800-827-6655.**

**\*Coverage in Canada varies on some items. For full details call Sears Canada at 1-800-361-6665.**

### **Sears Installation Service**

For Sears professional installation of home appliances, garage door openers, water heaters, and other major home items, in the U.S.A. or Canada call **1-800-4-MY-HOME®**.



# Get it fixed, at your home or ours!

## Your Home

For troubleshooting, product manuals and expert advice:



[www.managemylife.com](http://www.managemylife.com)

For repair – **in your home** – of **all** major brand appliances, lawn and garden equipment, or heating and cooling systems, **no matter who made it, no matter who sold it!**

For the replacement parts, accessories and owner's manuals that you need to do-it-yourself.

For Sears professional installation of home appliances and items like garage door openers and water heaters.

**1-800-4-MY-HOME<sup>®</sup>** (1-800-469-4663)

Call anytime, day or night (U.S.A. and Canada)

[www.sears.com](http://www.sears.com)    [www.sears.ca](http://www.sears.ca)

## Our Home

For repair of carry-in items like vacuums, lawn equipment, and electronics, call anytime for the location of your nearest

**Sears Parts & Repair Service Center**

**1-800-488-1222** (U.S.A.)    **1-800-469-4663** (Canada)

[www.sears.com](http://www.sears.com)

[www.sears.ca](http://www.sears.ca)

To purchase a protection agreement on a product serviced by Sears:

**1-800-827-6655** (U.S.A.)

**1-800-361-6665** (Canada)

Para pedir servicio de reparación a domicilio, y para ordenar piezas:

**1-888-SU-HOGAR<sup>®</sup>**

(1-888-784-6427)

[www.sears.com](http://www.sears.com)

Au Canada pour service en français:

**1-800-LE-FOYER<sup>MC</sup>**

(1-800-533-6937)

[www.sears.ca](http://www.sears.ca)

The Sears logo, consisting of the word "sears" in a lowercase, serif font.