

BRINKMANN®

ProSeries™

**2200 Gas Porcelain
Outdoor Grill**

OWNER'S MANUAL

ASSEMBLY AND OPERATING INSTRUCTIONS

SAVE THIS MANUAL FOR FUTURE REFERENCE

**NOTICE TO INSTALLER:
LEAVE THESE INSTRUCTIONS
WITH THE GRILL OWNER FOR
FUTURE REFERENCE.**

⚠ WARNING

HAZARDOUS EXPLOSION MAY
RESULT IF THESE WARNINGS AND
INSTRUCTIONS ARE IGNORED. READ
AND FOLLOW ALL WARNINGS AND
INSTRUCTIONS IN THIS MANUAL TO
AVOID PERSONAL INJURY, INCLUDING
DEATH OR PROPERTY DAMAGE.

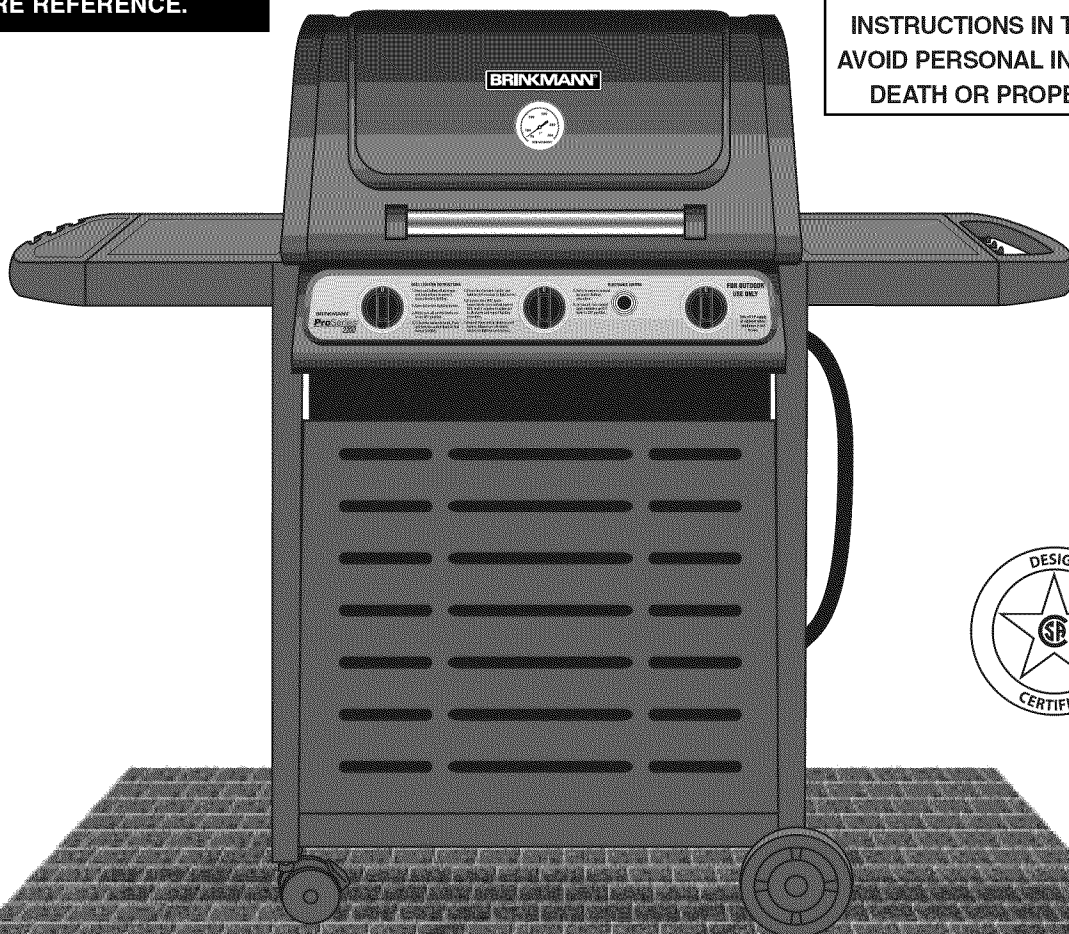



IMPORTANT SAFETY WARNINGS

WE WANT YOU TO ASSEMBLE AND USE YOUR GRILL AS SAFELY AS POSSIBLE. THE PURPOSE OF THIS SAFETY ALERT SYMBOL  IS TO ATTRACT YOUR ATTENTION TO POSSIBLE HAZARDS AS YOU ASSEMBLE AND USE YOUR GRILL.

WHEN YOU SEE THE SAFETY ALERT SYMBOL  PAY CLOSE ATTENTION TO THE INFORMATION WHICH FOLLOWS!

 READ ALL SAFETY WARNINGS AND INSTRUCTIONS CAREFULLY BEFORE ASSEMBLING AND OPERATING YOUR GRILL.

DANGER

FOR YOUR SAFETY:

IF YOU SMELL GAS:

1. Shut off gas to the appliance at the LP cylinder and burners.
2. Extinguish any open flame.
3. Open the Lid.
4. If odor continues, leave the area and immediately call your gas supplier or your fire department.

WARNING

FOR YOUR SAFETY:

1. DO NOT store or use gasoline or other liquids with flammable vapors in the vicinity of this or any other appliance.
2. An LP cylinder not connected for use shall not be stored in the vicinity of this or any other appliance to avoid the possibility of explosion.

WARNING



- DO NOT store a spare LP gas cylinder under or near this appliance.
- Never fill the cylinder beyond 80% full.
- If the above is not followed exactly, a fire causing death or serious injury may occur.

⚠ WARNING

- Never use natural gas in a unit designed for liquid propane gas.
- Never use charcoal briquets or lighter fluid in a gas grill.
- Leak test all connections before first use, even if grill was purchased fully assembled and after each tank refill.
- Never check for leaks using a match or open flame.

⚠ CAUTION! Strong odors, colds, sinus congestion, etc. may prevent the detection of propane. Use caution and common sense when testing for leaks.

- Always keep gasoline, paint thinner, or other flammable liquids or combustible materials away from your gas grill.
- Always check the grill prior to each use as indicated in the "Pre-Start Check List" section of this manual.
- Keep children and pets away from hot grill. **DO NOT** allow children to use or play near this grill.
- **DO NOT** leave the grill unattended while in use.
- **DO NOT** allow the gas hose to come in contact with hot surfaces.
- **DO NOT** allow grease from drain hole to fall on hose or valve regulator assembly.
- Keep any electrical supply cords away from water or heated surfaces.
- Keep a fire extinguisher on hand acceptable for use with gas products. Refer to your local authority to determine proper size and type.
- For household use only. **DO NOT** use this grill for anything other than its intended purpose.
- **DO NOT** use while under the influence of drugs or alcohol.
- Grill is hot when in use. To avoid burns:
 - **DO NOT** attempt to move the grill.
 - Lock the wheels so the unit does not accidentally move.
 - Wear protective gloves or oven mitts.
 - **DO NOT** touch any hot grill surfaces.
 - **DO NOT** wear loose clothing or allow hair to come in contact with grill.

⚠ USE CAUTION AND COMMON SENSE WHEN OPERATING YOUR GAS GRILL. FAILURE TO ADHERE TO THE SAFETY WARNINGS AND GUIDELINES IN THIS MANUAL COULD RESULT IN SEVERE BODILY INJURY OR PROPERTY DAMAGE.

SAVE THIS MANUAL FOR FUTURE REFERENCE.

⚠ WARNING

- **FOR OUTDOOR USE ONLY. DO NOT** operate in a building, garage or other enclosed area such as a shed or breezeway.
- Use your grill **OUTDOORS** in a well ventilated space away from dwellings or other buildings to prevent dangers associated with gas accumulation and toxic vapors. We recommend your grill be situated at least 10 feet from buildings.
- Maintain a minimum clearance of 24 inches (60 cm) between all sides of grill and walls or other combustible material. Do not use grill under overhead unprotected combustible construction.
- **DO NOT** use or install this grill in or on a recreational vehicle and/or boat.

INSTALLATION INFORMATION:

The installation of this appliance must be in accordance with:

All applicable local codes, or in the absence of local codes, either:

- National Fuel Gas Code ANSI Z223.1 NFPA 54
- Natural Gas and Propane Installation Code: CAN/CGA B149.1

To check your local codes, see your local LP gas dealer or natural gas company.

This grill was not intended to be connected to a natural gas supply line. If an external electrical source is utilized, it must be electrically grounded in accordance with local codes, or in the absence of local codes, with the National Electrical Code, ANSI/NFPA 70, or the Canadian Electrical Code, CSA 22.1.

⚠ WARNING

LP GAS CYLINDER

The LP cylinder is available for purchase at the same location grill was purchased

The LP (Liquid Propane) gas cylinder specifically designed to be used with this grill must have a 20 lb. (9.1 kg) capacity incorporating a Type 1 cylinder valve and an over-filling protection device (OPD).

- **DO NOT** connect this grill to an existing #510 POL cylinder valve with Left Hand threads. The Type 1 valve can be identified with the large external threads on the valve outlet.
- **DO NOT** connect to a propane cylinder exceeding this capacity.
- **DO NOT** connect to a cylinder that uses any other type of valve connection device.

CYLINDER SPECIFICATIONS:

When purchasing or exchanging a cylinder for your gas grill, it must be constructed and marked in accordance with the specifications for LP gas cylinders of the U.S. Department of Transportation (DOT) or the National Standard of Canada, CAN/CSA-B339 Cylinders, Spheres and Tubes for Transportation of Dangerous Goods; and Commission, as applicable; and provided with a listed over-filling prevention device (OPD), and provided with a cylinder connection device compatible with the connection for outdoor cooking appliances.

The cylinder must also be equipped with:

- A shut-off valve terminating in a Type 1 gas cylinder valve outlet.
- A Type 1 valve that prevents gas flow until a positive seal is obtained.
- An arrangement for vapor withdrawal.
- A collar to protect the cylinder shut-off valve.
- A safety relief device having direct communication with the vapor space of the cylinder.
- A listed over-filling prevention device (OPD).

⚠ WARNING

- **Turn off the cylinder valve when your grill is not in use.**
- **Handle the tank with care.**
- **Always secure the cylinder in an upright position.**
- **Never connect an unregulated LP gas cylinder to your grill.**
- **DO NOT expose LP gas cylinders to excessive heat or ignition sources.**
- **DO NOT store a spare LP gas cylinder under or near your grill.**
- **Allow only qualified LP gas dealers to fill or repair your LP gas cylinder.**
- **DO NOT allow the cylinder to be filled beyond 80% capacity.**
- **Read and follow all warnings and instructions that are on the cylinder and that accompany this product.**

⚠ DANGER

- **Never store a spare LP gas cylinder under or near your grill. This could cause excess pressure to be expelled through the vapor relief valve resulting in fire, explosion, or severe personal injury including death.**

**NOTE: PROPANE GAS IS HEAVIER THAN AIR AND WILL COLLECT IN LOW AREAS.
PROPER VENTILATION IS EXTREMELY IMPORTANT.**

- **Keep the ventilation opening(s) of the LP gas cylinder enclosure free and clear from obstructions and debris.**
- **DO NOT insert any foreign objects into the valve outlet. Damage to the back-check could result. A damaged back-check can cause a leak, possibly resulting in explosion, fire, severe bodily harm, or death.**

⚠ WARNING

FILLING THE LP GAS CYLINDER:

- Allow only qualified LP gas dealers to properly fill or repair your LP gas cylinder.
- New tanks should be purged prior to filling; inform LP gas dealer if you are using a new tank.
- **DO NOT** allow the cylinder to be filled beyond 80% capacity. Over-filled tanks can create a dangerous condition. Over-filled tanks can build-up pressure and cause the relief valve to expel propane gas vapors. The vapor is combustible and if it comes in contact with a spark source or flame an explosion causing severe burns, bodily harm, or death could occur.
- Always use a protective cylinder cap when grill is not connected to cylinder.
- If you exchange a cylinder with a qualified exchange program, be sure the cylinder has a Type 1 valve and an over-filling prevention device (OPD).

INSTALLING THE LP GAS CYLINDER ONTO THE GRILL:

1. Check that the cylinder valve is closed by turning the knob clockwise.
2. Place the cylinder into the tank holder in the bottom of cabinet.
3. Orient the cylinder such that the valve opening faces the right side of the grill.
4. Fully tighten the wing bolt lock underneath tank holder to secure tank.
5. Attach or detach regulator to the LP gas cylinder only when cylinder is at rest in tank holder.

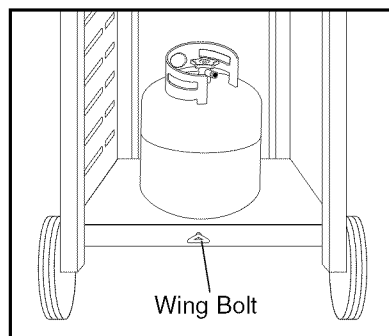
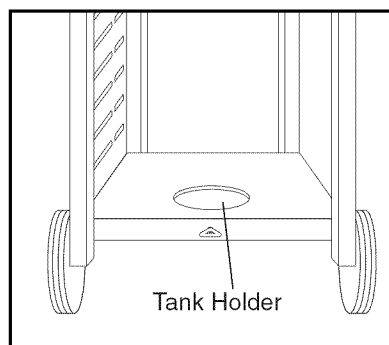

HOSE AND REGULATOR:

Your grill is equipped with a Type 1 connection device with the following features:

1. The system will not allow gas flow from the cylinder until a positive connection to the valve has been made.

NOTE: The cylinder valve must be turned off before any connection is made or removed.
2. A thermal device that will shut off the gas flow if the device is subject to temperatures above 240°F to 300°F (115°C to 150°C). If this should happen, remove the entire regulator assembly and dispose of properly. A replacement regulator assembly can be purchased by contacting Brinkmann at 1-800-527-0717. The cause of the excessive heat should be determined and corrected before using your grill again.
3. A flow limiting device, when activated, restricts the flow of gas to 10 cubic feet per hour.

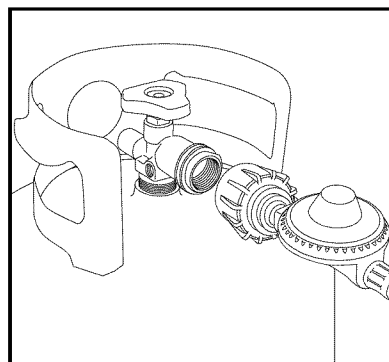

⚠ WARNING

- Never use your grill without leak testing all gas connections and hoses. See the section on "Leak Testing" in this manual for proper procedures.

⚠ WARNING

The pressure regulator and hose assembly supplied with your gas grill must be used.

- DO NOT attempt to connect it to any other fuel supply source such as a natural gas line.
- DO NOT use any other pressure regulator/hose assembly other than the one supplied with your grill. Replacement pressure regulator/hose assembly must be Brinkmann No 155-2200-0, which can be obtained by contacting Brinkmann at 1-800-527-0717.
- DO NOT attempt to adjust or repair the regulator. The regulator is designed to operate at a maximum output pressure of 11 inches of water column (2.74 kPa).

During assembly and/or replacement of the gas cylinder, keep the gas supply hose free of kinks and/or damage.

Visually inspect the hose assembly prior to each use for evidence of damage, excess wear, or deterioration. If found, replace the assembly before using your grill. Only the Brinkmann supplied replacement should be used.

⚠ WARNING

CONNECTING HOSE AND REGULATOR TO AN LP GAS CYLINDER

- Insure the tank valve is **CLOSED** prior to connecting the LP gas cylinder to your grill. Turn the valve knob clockwise to properly close the valve. Read and follow all instructions and warnings on the supply hose safety tags. Read and follow all warnings in this manual concerning the safe use of LP gas cylinders and the hose and regulator before connecting cylinder to grill. Read and follow all warnings on the LP cylinder.

1. Check that the cylinder valve is closed by turning the knob clockwise.
2. Check that the grill's burner knobs are in the OFF positions.
3. Remove the protective plastic cap from the cylinder valve and the connection device.
4. Insert the nipple of connection device into the valve outlet. Insure that the device is centered properly.
5. Turn the large coupling nut clockwise by hand and tighten to a full stop. Take care not to cross thread the coupling nut onto the cylinder valve. Do not over-tighten the knob onto the valve. Do not use tools to tighten connection.

NOTE: If you are unable to make the connection, repeat Steps 4 and 5.

6. Check that the hose does not contain kinks, does not contact sharp edges, and does not contact surfaces that may become hot during use.
7. Leak check all fittings before lighting your grill. See section on "Leak Testing" in this manual.

⚠ DANGER

LEAK TESTING:

To prevent fire or explosion hazard:

- DO NOT smoke or permit ignition sources in the area while conducting a leak test.
- Perform test OUTDOORS only in a well ventilated area.
- Never perform a leak test with a match or open flame.
- Never perform a leak test while the grill is in use or while grill is still hot.

⚠ WARNING

WHEN TO PERFORM A LEAK TEST:

- After assembling your grill and before lighting for the first time, even if purchased fully assembled.
- Every time the LP gas cylinder is refilled or if any of the gas components are replaced.
- Any time your grill has been moved.
- At least once per year or if your grill has not been used for more than 60 days.

CHECKING FOR LEAKS:

1. Create a mixture of 50% water and 50% liquid dishwashing soap.
2. Open the lid.
3. Insure all burner knobs are set to the OFF position.
4. To turn on the fuel supply, turn the cylinder valve knob one turn counterclockwise.
5. Apply the soap water mixture to the following:

Watch For Bubbles

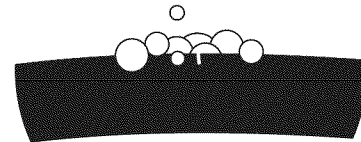

- Ⓐ Supply tank (cylinder) weld
- Ⓑ Connection nut to tank valve.
- Ⓒ Back side of connection nut to brass nipple.
- Ⓓ Brass nipple connection into regulator.
- Ⓔ Regulator connections to gas supply hoses.
- Ⓕ Hose connection to gas manifold.
- Ⓖ The full length of gas supply hose
- Ⓗ Tank valve to cylinder

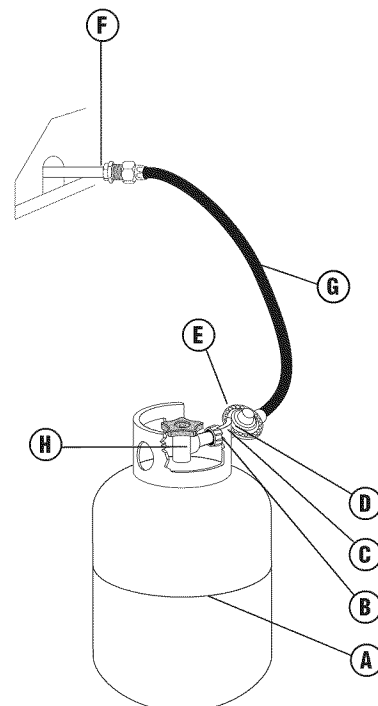

6. Check each place listed (A - H) for growing bubbles which indicates a leak.
7. Turn OFF gas supply at cylinder valve.
8. Turn on control knobs to release gas pressure in hose.
9. Turn control knobs to OFF position.
10. Tighten any leaking connections.
11. Repeat soapy water test until no leaks are detected. **DO NOT** use the grill if leaks cannot be stopped. Contact a qualified gas appliance repair service.
12. Turn OFF gas supply at cylinder valve until you are ready to use your grill.
13. Wash off soapy residue with cold water and towel dry.
14. Wait 5 minutes to allow all gas to evacuate the area before lighting grill.

NOTE: The leak test must be performed in an area that has adequate lighting in order to see if bubbles are developing. **DO NOT** use a flashlight to check for bubbles.

WARNING

PRE-START CHECK LIST:

Property damage, bodily harm, severe burns, and death could result from failure to follow these safety steps. These steps should be performed after the grill has been assembled and prior to each use. DO NOT operate this grill until you have read and understand ALL of the warnings and instructions in this manual.

- Ensure that the grill is properly assembled.
- Inspect the gas supply hose for burns, chaffing, kinks, and proper routing before each use. If it is evident there is excessive abrasion or wear, or the hose is cut, it must be replaced prior the grill being used. Replace with hose and regulator, Model No. 155-2200-0, which can be obtained by contacting Brinkmann at 1-800-527-0717.
- Leak check all gas connections and hose. See section on "Leak Testing".
- Ensure that all electrical supply cords are properly grounded. Keep any electrical supply cord and the fuel supply hose away from any heated surfaces. Hose should be at least 3 inches from hot surfaces.
- Position your grill on level ground in a well ventilated location, a safe distance from combustible materials, buildings and overhangs.
- Properly place the empty grease tray under the grease drain hole in the bottom of the grill to catch grease during use.

WARNING

Read, understand and follow all warnings and instructions contained in this manual. DO NOT skip any of the warnings and instructions contained in the preceding sections of this manual.

⚠ WARNING

LIGHTING INSTRUCTIONS:

Follow the instructions exactly.

1. **OPEN THE GRILL LID** before attempting to light a burner so that fumes do not accumulate inside the grill. An explosion could occur if grill lid is down.
2. Check that all burner control knobs and the cylinder valve are turned to the **OFF** position.
3. Turn on the fuel supply by rotating the cylinder valve knob counterclockwise to full open.
4. **DO NOT** stand with head, body, or arms over the grill when lighting.

LIGHTING THE BURNERS:

1. Open lid before lighting burner.
2. Make sure all control knobs are in the **OFF** position.
3. Select the burner to be lit. Push and turn the control knob of that burner to the **HIGH** position.
4. Press the electronic igniter and hold for 3-5 seconds until burner ignites.
5. If burner does **NOT** ignite immediately, turn the burner control knob to **OFF**, wait 5 minutes for gas to evacuate the grill. Repeat Steps 1 through 5 until burner ignites.
6. If burner does not ignite using the push button igniter wait 5 minutes, see "Match Lighting the Main Burners" section.
7. Once lit, light adjacent burners in sequence by pressing in and rotating the control knob to the **HIGH** position.

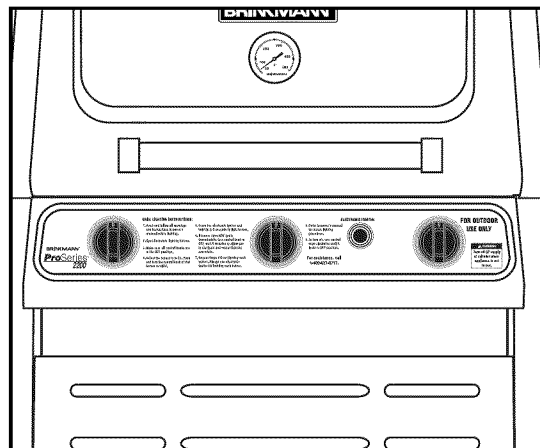

MATCH LIGHTING THE BURNERS:

1. Open lid before lighting.
2. Turn the burner control knobs to **OFF**.
3. Place a paper match in the end of the matchlighter. Strike the match and place through lighting hole in the left hand side of the grill to approximately 1/2" (2 to 3 cm) from the burner.
4. Turn on the **FAR LEFT** burner control knob to the **HIGH** position. The burner should light within 5 seconds.
5. If the burner does not light, turn the control knob to **OFF** and wait 5 minutes for gas to evacuate the grill. Repeat Steps 1 through 5 until the burner ignites.
6. Once lit, light adjacent burners in sequence by pressing in and rotating the control knob to the **HIGH** position.
7. If the burner does not light within the first few attempts of match lighting, there is a problem with the gas supply. Turn off the gas at the burner and cylinder. **DO NOT** attempt to operate the grill until the problem is found and corrected. See "Trouble Shooting" section of this manual.

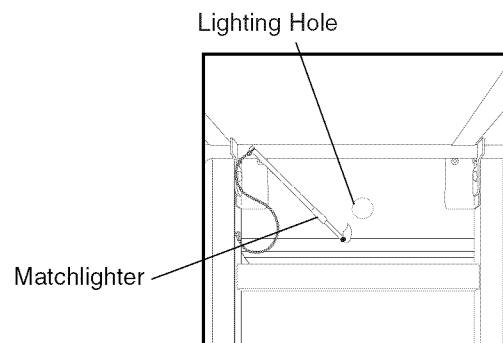

NOTE: Observe flame height when lit: Flame should be a Blue/Yellow color approximately 1" high when burner is on "High."

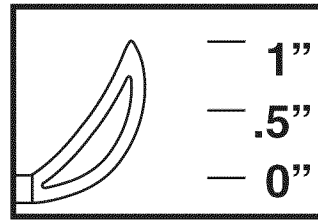

TURNING OFF THE GRILL:

1. Turn OFF the LP tank valve.
2. Turn all burner control knobs to the OFF position.

NOTE: Turn off LP cylinder first to prevent gas from being left in the system under pressure.

⚠ CAUTION!

- The LP tank valve should always be in the off, or closed, position when the grill is not in use.

To turn off the LP tank valve, turn knob clockwise until it stops.

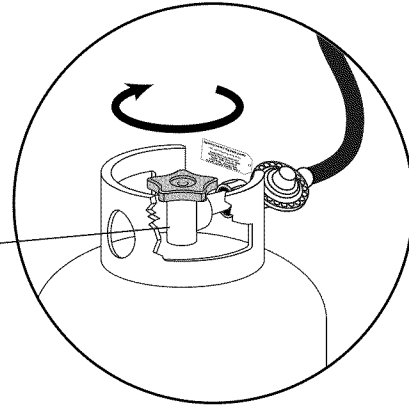

⚠ WARNING

OPERATING THE GRILL:

Never use Charcoal or Lighter Fluid inside your Gas Grill. Read and follow all warnings and instructions contained in the preceding sections of this manual.

BREAKING IN YOUR GRILL:

- In manufacturing and preserving the components of your grill, oil residue may be present on the burner and cooking surfaces of your grill.
- Before cooking on your grill for the first time you should operate it for 15 minutes on HIGH to burn off residual oils.

PREHEATING THE GRILL:

- Prior to use, it is recommended that you preheat your grill. This ensures that the grilling surfaces are at the desired temperatures to sear the food sugars when cooking. After lighting your grill, set the main burner control knobs to the HIGH position for 10 to 15 minutes. The top cover is to be closed during the preheat period.

CONTROLLING FLARE-UPS:

- Flare-ups are a part of cooking meats on a gas grill. This adds to the unique flavor of cooking on a gas grill. Excessive flare-ups can over-cook your food and cause a dangerous situation for you and your grill. Excessive flare-ups result from the build-up of grease in the bottom of your grill. If this should occur, DO NOT pour water onto flames. This can cause the grease to splatter and could result in serious burns or bodily harm. If grease fire occurs close the lid and turn off the main burners until the grease burns out. Use caution when re-opening the lid as sudden flare-ups may occur.

⚠ WARNING

- **DO NOT** leave your grill unattended while in use.
- **DO NOT** move grill when in use. Lock wheels in place to stabilize grill.
- **DO NOT** use water to extinguish flare-ups.
- Have fire extinguisher readily accessible suitable for use with gas appliances.

TO MINIMIZE FLARE-UPS:

- Trim excess fat from meats prior to cooking.
- Cook meats with high fat contents (chicken or pork) on Low settings or indirectly.
- Ensure that your grill is on level ground and the grease is allowed to evacuate the grill through the drain hole in the bottom and into drip pan.

INDIRECT COOKING:

- Indirect cooking is the process of cooking your food without the heat source being directly under your food. You can sear meats over a high flame on one side of the grill while slow cooking a roast on the other (unlit) side of the grill.

ROTISSERIE COOKING:

- Your grill was pre-drilled from factory to include mounting holes for a Brinkmann rotisserie (sold separately). Do not use a rotisserie not specifically manufactured for this grill.
- Read and follow all instructions provided with the rotisserie. Save instructions for future reference.

⚠ WARNING

- **When using an AC current rotisserie, it must be electrically grounded in accordance with local codes, or in the absence of local codes:**
 - **In the US: The National Electrical Code – ANSI-NFPA No. 70 – Latest Edition**
 - **In Canada: the Canadian Electrical Code – CSA C22.1**
- **Only use a Brinkmann Rotisserie manufactured specifically for use with this grill.**
- **The Rotisserie is equipped with a three pronged plug for your protection against electrical shock. This plug should be plugged directly into a properly grounded 3 prong receptacle. Never cut or remove the grounding plug. Any extension cord must also have a 3 prong receptacle.**
- **All electrical supply cords should be kept away from water and any hot surfaces of the grill.**

⚠ WARNING

TRANSPORTING AND STORAGE:

- Never move a grill when it is hot or when objects are on the cooking surfaces.
- Make sure that cylinder valve is shut off. After moving the grill check that all gas connections are free of leaks. Refer to instructions for leak test on Page 7 of this manual.
- DO NOT store a spare LP gas cylinder (filled or empty) under or near the grill.
- Never store flammable liquids or spray canisters under or near the grill.
- DO NOT extinguish grease fires using water.
- If the outdoor cooking gas appliance is not in use, the gas must be turned off at the supply cylinder.
- Storage of an outdoor cooking gas appliance indoors is permissible only if the cylinder is disconnected and removed from the outdoor cooking gas appliance.
- Cylinders must be stored outdoors out of reach of children and must not be stored in a building, garage or any other enclosed area.

BEFORE STORING YOUR GRILL:

- Ensure that the fuel supply tank valve is fully closed.
- Clean all surfaces.
- Lightly coat the burners with cooking oil to prevent excess rusting.
- If storing the grill indoors, disconnect the LP tank and leave the LP tank OUTDOORS.
- Place a protective cap cover on the LP tank and store the tank outdoors in a well ventilated area out of direct sunlight.
- If storing the grill outdoors, cover the grill with a grill cover for protection from the weather. A grill cover can be purchased by contacting: The Brinkmann Corporation at 1-800-527-0717.

CLEANING AND MAINTENANCE:

- Keep grill area clear and free from combustible materials, gasoline or other flammable vapors and liquids.
- Keep the ventilation openings of the cylinder enclosure free and clear from debris.
- Visually check burner flames for proper operation (see pictorial on Page 14).
- For safe grilling and peak performance of your grill, perform these checks at least twice per year or after extended periods of storage.
- Be sure to tighten up all hardware (nuts, bolts, screws, etc.) at least twice per year.
- Remove the cooking grills, heat shields, and burners from inside your grill. Use a brush with hot water and detergent to remove excess residue. NEVER use a commercial oven cleaner. Rinse completely with water. Towel dry and replace all components as described in the assembly instructions.

BURNER ASSEMBLY/MAINTENANCE

- Although your burners are constructed of cast iron, they may rust as a result of the extreme heat and acids from cooking foods. Regularly inspect the burners for cracks, abnormal holes, and other signs of corrosion damage. If found, replace the burner.
- **DO NOT obstruct the flow of combustion and ventilation air.** Burner tubes can become blocked by spiders and other insects building their nests. Blocked burner tubes can prevent gas flow to the burners and could result in a burner tube fire or fire beneath the grill. To clean the Burner Assembly follow these instructions to clean and/or replace parts of burner assembly or if you have trouble igniting the grill.
 1. Turn gas off at control knobs and LP cylinder tank valve.
 2. Remove cooking grills and heat shields.
 3. Remove cotter pins from beneath each burner "foot" using a screwdriver or needle nose pliers.
 4. Carefully lift each burner up and away from valve openings.
 5. Use a narrow bottle brush or a stiff wire bent into a small hook to run through each burner tube and flame port several times

NOTE: Wear eye protection when performing procedure 6.

6. Use compressed air to blow into burner tube and out the flame ports. Check each port to make sure air comes out each hole.
7. Wire brush entire outer surface of burner to remove food residue and dirt.
8. Check burner for damage, if any large cracks or holes are found replace burner.

IMPORTANT: Burner opening must slide over valve nozzle.

9. Carefully replace burners.
10. Replace cotter pin beneath each burner. Follow instructions on Page 9 and relight burners to verify proper operation.
11. Replace heat shields and cooking grills.

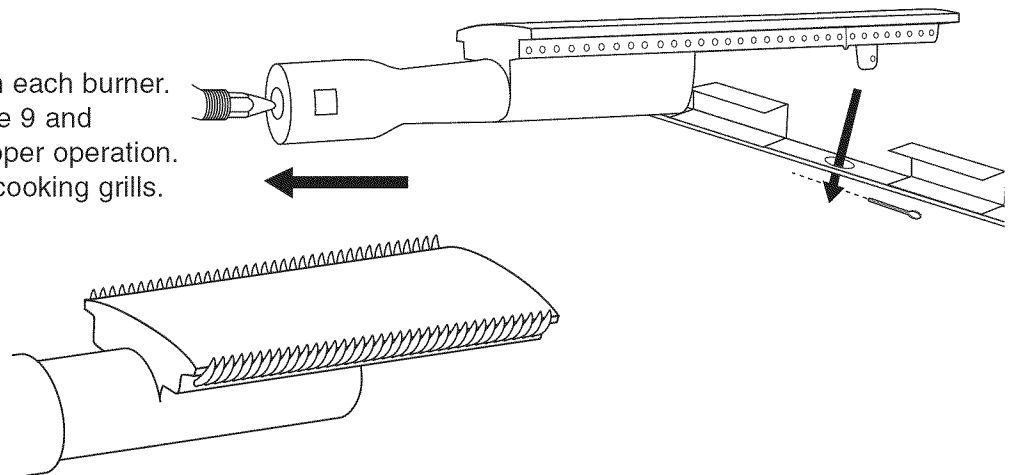

PROPER BURNER OPERATION

COOKING GRILLS

- Clean with mild soap detergent and water. Do not use steel wire bristles to clean the porcelain coated cooking grills. Steel can cause the finish to chip or crack. DO NOT use a commercial oven cleaner.

TROUBLE SHOOTING:

Problem:

Possible Causes:

- **Burner will not light**
 1. Check LP cylinder fuel level.
 2. Bad electrode spark.
Check to see if the grill will “match light.” (See Page 9)
Electrode or collector may need adjustment.
 3. Burner may not be properly seated.
 4. Burner may be obstructed.
 5. The cylinder valve may be closed.
 6. Regulator is not properly seated on cylinder valve.

- **Fire at control knobs**
 1. Burner holes may be obstructed. See section on Cleaning and Maintenance of the Burner holes.
 2. Burner is improperly seated on control valve.
 3. Gas connections may be loose.
Leak Check and tighten all connections.

- **Yellow Flames at burner**
 1. Burner is obstructed. See section on Cleaning and Maintenance of the Burner.

- **Flame blows out on “LOW”**
 1. Burner holes may be obstructed. See section on Cleaning and Maintenance of Burners.
 2. Grill is not sufficiently preheated.
 3. Burner is improperly seated on control valve.

- **Burner does not get hot enough**
 1. Flow control device has been activated in regulator.
 2. Turn off grill and the fuel supply. Disconnect grill from cylinder valve. Reconnect grill to cylinder and light grill. See section on Connection to the LP Cylinder.

- **Grill is Too Hot**
 1. Excess grease build-up causing grease fires.
 2. Damaged or faulty regulator.
Replace with Brinkmann parts.
 3. Cook on a lower temperature setting.

PROPER CARE & MAINTENANCE

- To protect your grill from excessive rust, the unit must be kept clean and covered at all times when not in use. A grill cover may be ordered directly from Brinkmann by calling 1-800-468-5252 or 1-800-527-0717.
- Wash cooking grills and heat shields with hot, soapy water, rinse well and dry. Lightly coat cooking grill with vegetable oil or vegetable oil spray.
- Clean inside and outside of grill by wiping off with a damp cloth. Apply a light coat of vegetable oil or vegetable oil spray to the interior surface to prevent rusting.
- If rust appears on the exterior surface of your grill, clean and buff the affected area with steel wool or fine grit emery cloth. Touch-up with a good quality high-temperature resistant paint.
- Never apply paint to the interior surface. Rust spots on the interior surface can be buffed, cleaned, then lightly coated with vegetable oil or vegetable oil spray to minimize rusting.

GRILL COOKING TIPS

CLEANLINESS

- Always wash hands thoroughly with soap and hot water prior to handling food and after handling raw meat, un-cooked poultry or seafood.
- When using a platter to carry raw meat, un-cooked poultry or seafood to the grill, make sure to wash the platter thoroughly with soap and hot water before placing cooked foods back on the platter or use different platters for raw and cooked foods.
- Never use the same utensils when handling raw meat, un-cooked poultry or seafood unless you wash the utensils thoroughly with soap and hot water.
- Never re-use marinade from raw meat or un-cooked poultry on foods that have been cooked and are ready to be served.

GRILLING TO PROPER TEMPERATURE

- Use a meat thermometer to be sure food has reached a safe internal temperature. You may order a Commercial-quality thermometer from Brinkmann. For more information on this product and other Brinkmann accessories, please refer to the accessory Pages at the end of this manual.
- The US Department of Agriculture recommends the **minimum** temperature be reached for the following food items:

Chops	145 degrees F
Ground Meat	160 degrees F
Pork	160 degrees F
Poultry	180 degrees F
Roasts	145 degrees F

HELPFUL HINTS

- If you pre-cook meat or poultry, do so immediately before grilling.
- Never defrost meat at room temperature or on a countertop.
- Refrigerate leftovers within 2 hours of taking food off the grill.
- For additional information, please phone the USDA's toll free Meat & Poultry Hotline at 1-800-535-4555.

ASSEMBLY INSTRUCTIONS

▲ READ ALL SAFETY WARNINGS & ASSEMBLY INSTRUCTIONS CAREFULLY BEFORE ASSEMBLING OR OPERATING YOUR GRILL.

WE RECOMMEND TWO PEOPLE WORK TOGETHER WHEN ASSEMBLING THIS UNIT.

The following provided tools are required to assemble this Brinkmann Pro Series 2200 Grill:

- Flathead Screwdriver
- Hex Nut Wrench

PARTS LIST:

①	1	Grill Body Assembly	⑩	1	Grease Cup
②	1	Electronic Igniter Button	⑪	1	Tank Heat Shield
③	1	Electronic Igniter Spring	⑫	1	Heat Shield Plate
④	1	Warming Rack	⑬	1	Cart Assembly
⑤	2	Cooking Grills	⑭	2	Locking Casters
⑥	2	Heat Tents	⑮	2	Hubcaps
⑦	1	Grill Bottom	⑯	2	Wheels
⑧	1	Left Side Table	⑰	1	Hose Heat Shield
⑨	1	Right Side Table			

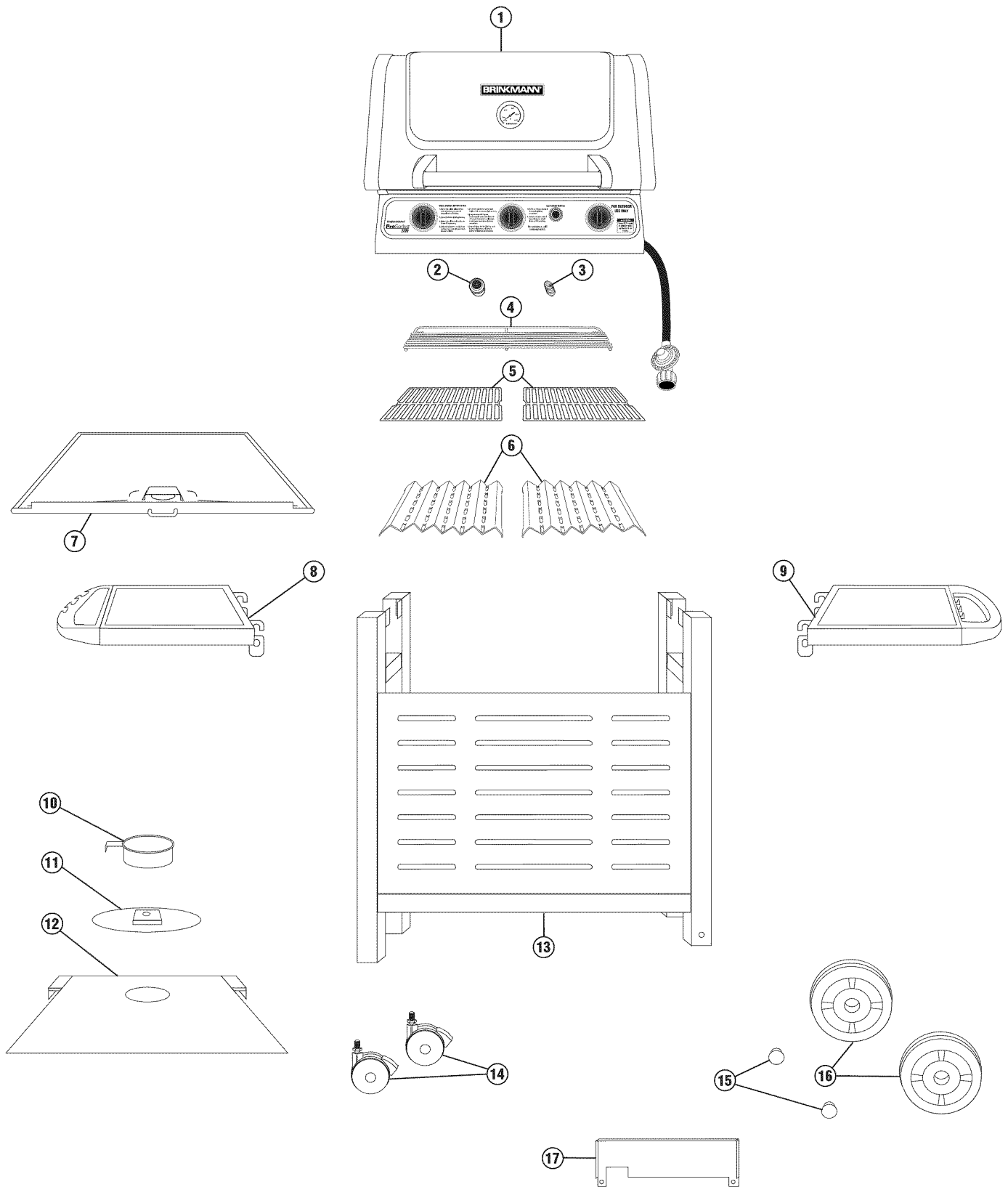

FOR MISSING PARTS, PLEASE CALL CUSTOMER SERVICE AT 1-800-527-0717.

(Proof of purchase will be required.)

Inspect contents of the box to ensure all parts are included and undamaged.

PARTS BAG CONTENTS

Make sure you have all items listed under **PARTS LIST** and **PARTS BAG CONTENTS** before you begin the installation process.

Your Parts Bag will include:

Qty.

- 4 M8 X 15mm bolts
- 6 M6 X 12mm bolts
- 1 AA/1.5V Alkaline battery
- 4 Large Star Washers
- 6 Small Star Washers

Qty.

- 2 Wheel washers
- 2 Wheel axle bolts
- 1 Screwdriver
- 1 Hex Nut Wrench
- 6 #8 Self-Tapping Screws

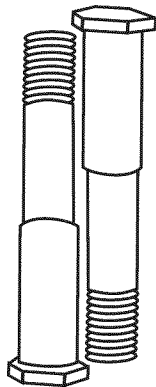
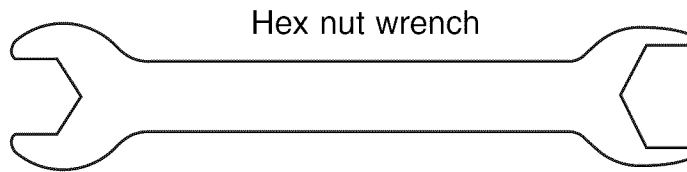

Wheel axle bolts

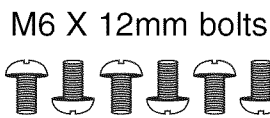

AA/1.5V Alkaline battery

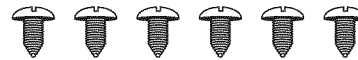

M8 X 15mm bolts

#8 Self-Tapping Screws

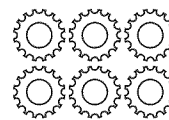
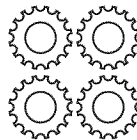

Small Star Washers

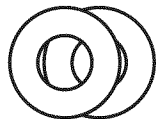

Wheel washers

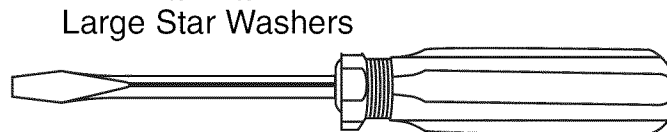

Screwdriver

Choose a good, cleared assembly area and get a friend to help you put your grill together. Lay cardboard down to protect grill finish and assembly area.

Step 1

With the help of a friend, turn the preassembled cart over. Try to minimize the stress to the bottom plate.

Step 2

Attach locking casters to the bottom of the left side cart panel. Tighten caster bolts securely using hex nut wrench provided in parts pack.

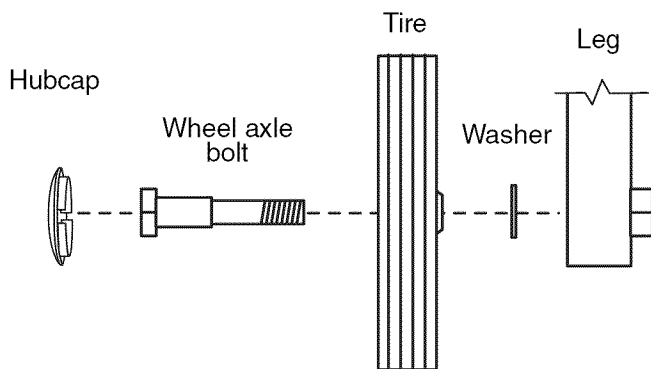
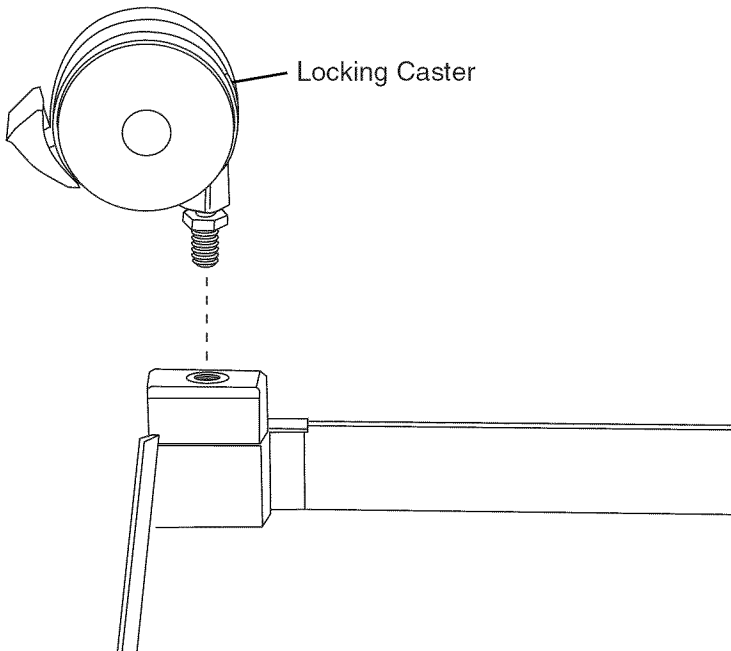

Step 3

Install the wheels as illustrated, by inserting the wheel axle bolts through the wheels, washers and right side panel axle holes. Tighten axle bolts securely using hex nut wrench provided in parts pack.

Step 4

Snap wheel hub caps onto the outside of wheels as illustrated.

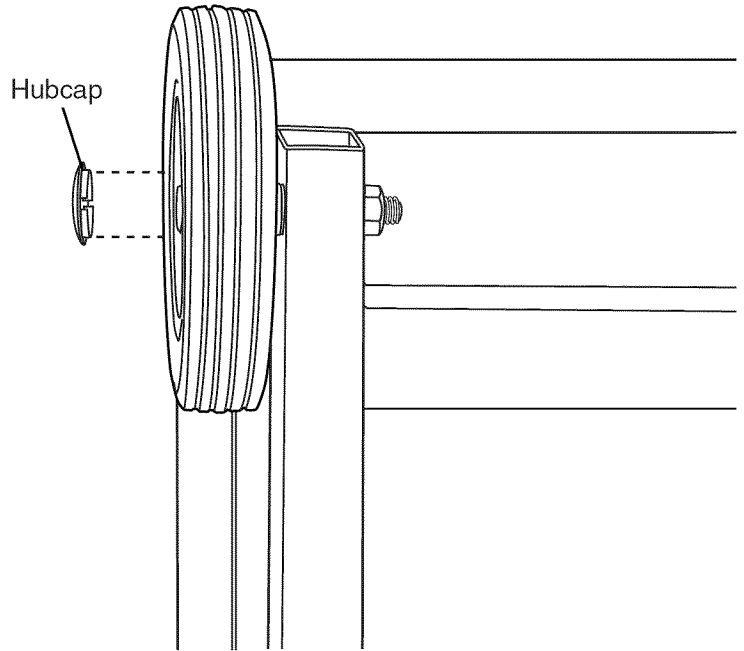

Step 5

With the help of a friend, turn the cart to its upright position.

Step 6

Attach tank heat shield to heat shield plate using one #8 self-tapping screw.

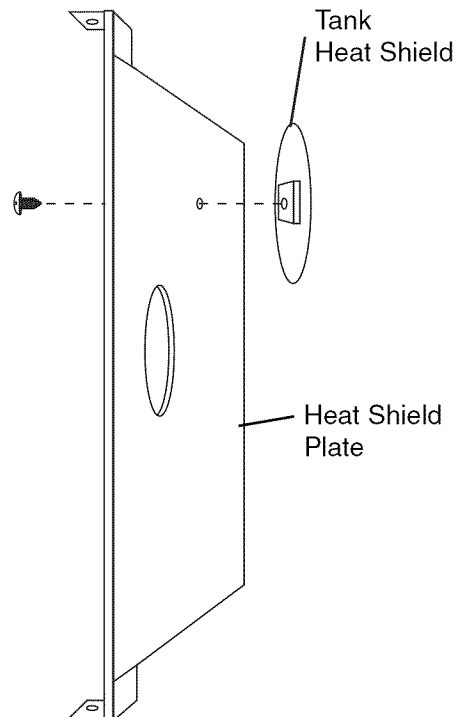

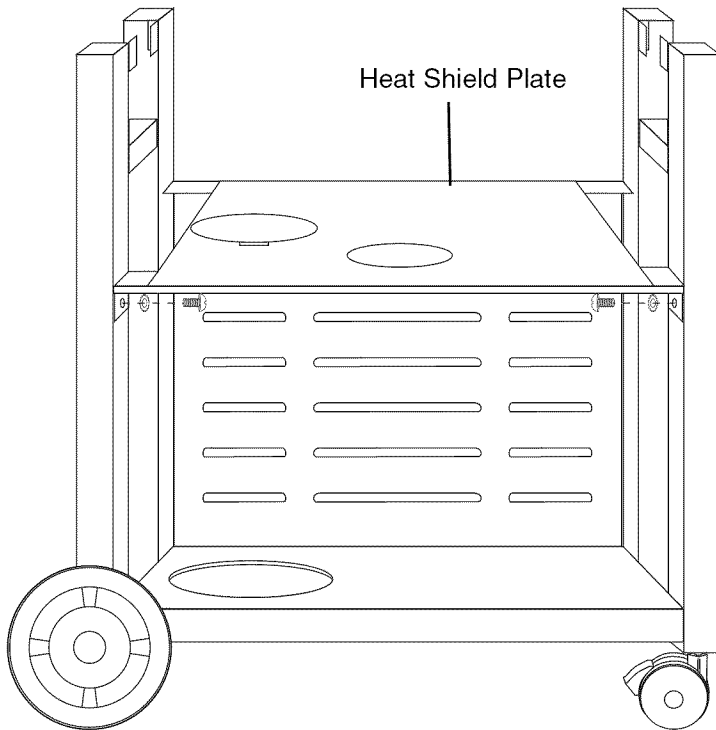

Step 7

Attach heat shield plate to back panel using two M6 X 12mm bolts with small star washers.

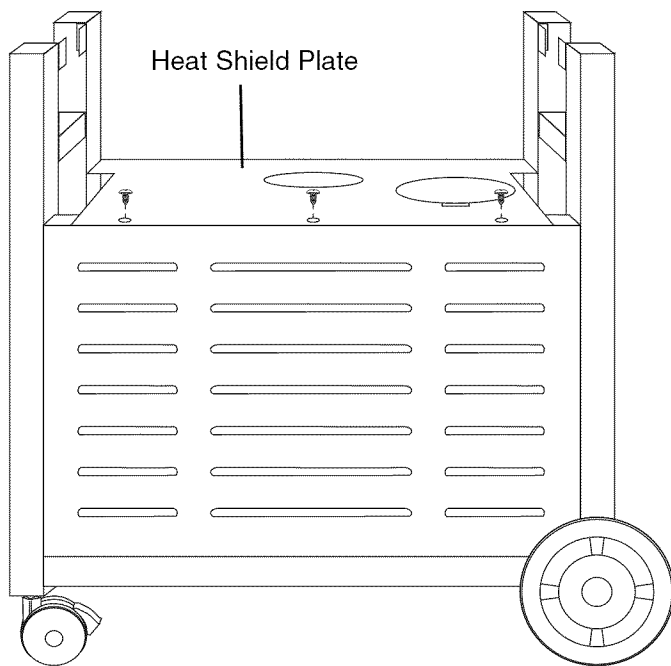

Step 8

Attach heat shield plate to front panel using three #8 self-tapping screws.

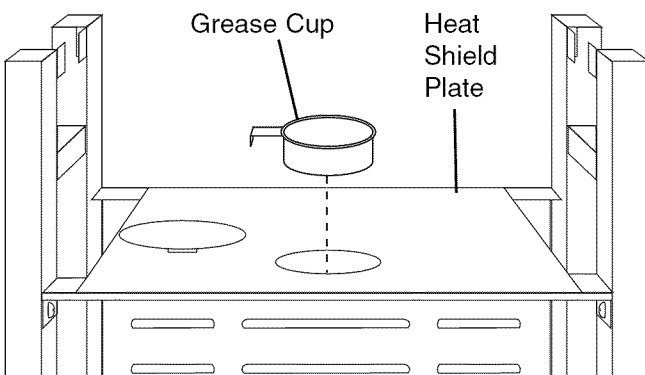

Step 9

Place grease cup in middle of hole in heat shield plate.

Note: When performing Step 10, Lift grill body from front and rear panels to avoid injury to hands and fingers. Be sure to pass hose/regulator assembly above cart frame crossbar.

Step 10

With the help of a friend, place grill body assembly on preassembled cart frame. Grill body will rest on angled top of vertical supports. Align bolt holes located on the outside of the grill body assembly. Secure using four M6 X12mm bolts with small star washers.

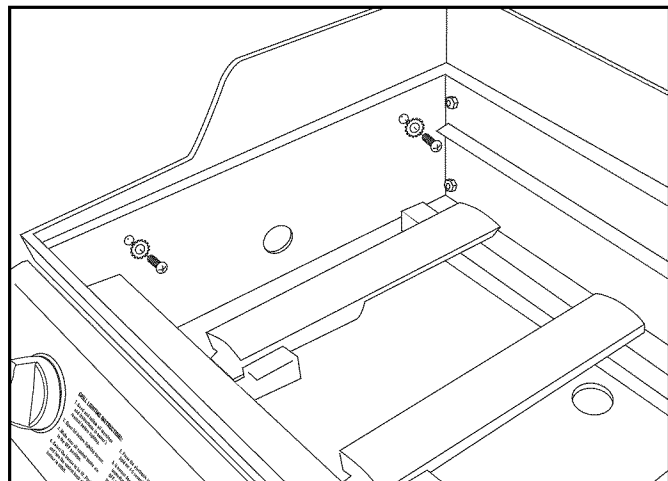
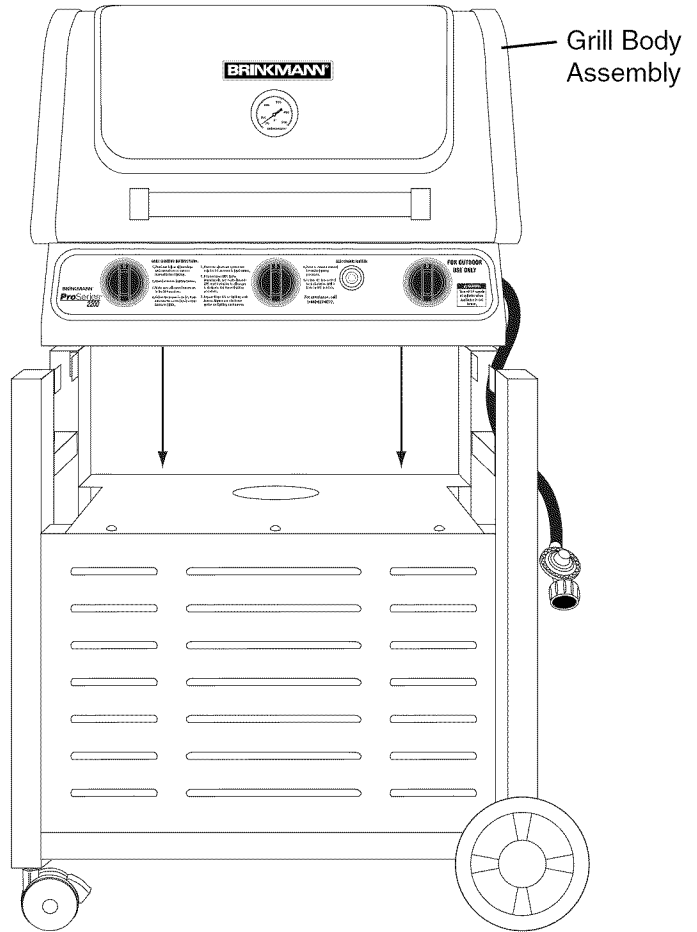
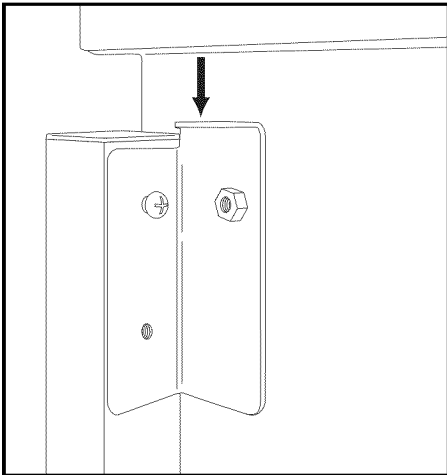

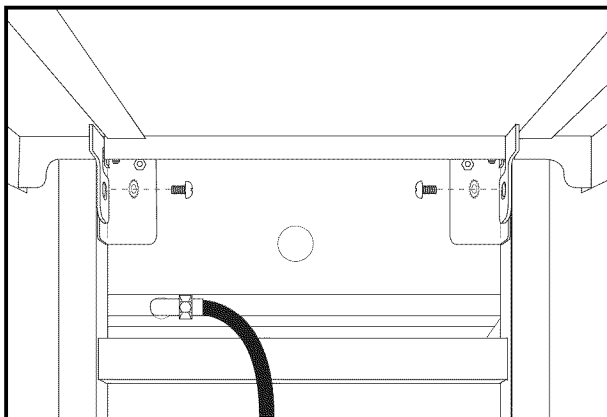
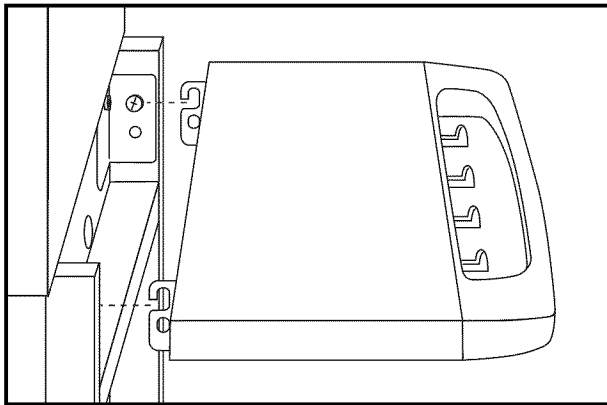
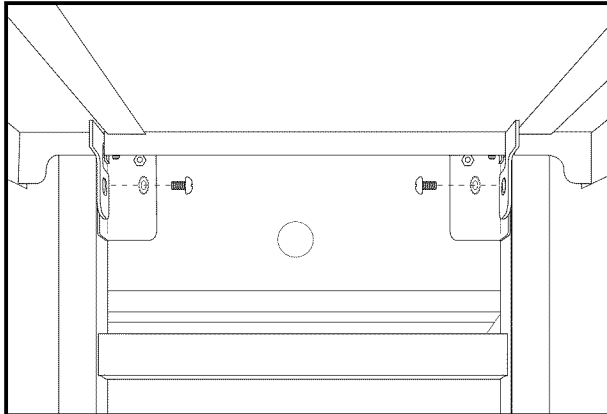
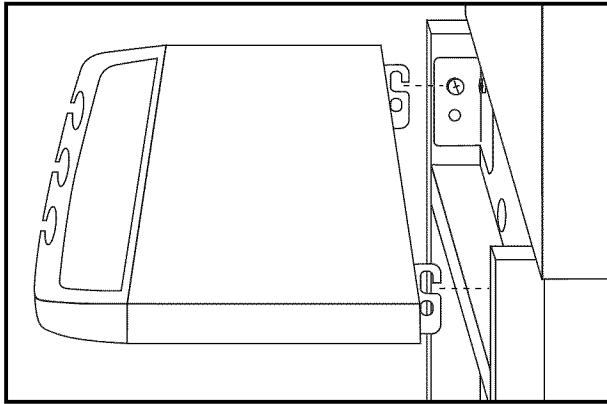

Step 11

Attach left side table assembly to left side of cart frame assembly. Slide side table assembly onto preattached shoulder bolts. Attach two M8 X 15 mm bolts with large star washers as illustrated and secure.

Step 12

Attach right side table assembly to right side of cart frame assembly. Slide side table assembly onto preattached shoulder bolts. Attach two M8 X 15 mm bolts with large star washers as illustrated and secure.

Step 13

Attach the hose heat shield to the right side of the cart frame using two #8 self-tapping screws.

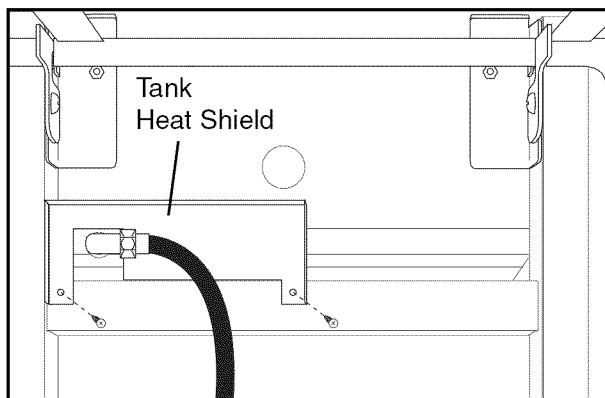

Step 14

Insert grease tray into opening on backside of grill. Make sure to slide tray onto tracks as illustrated.

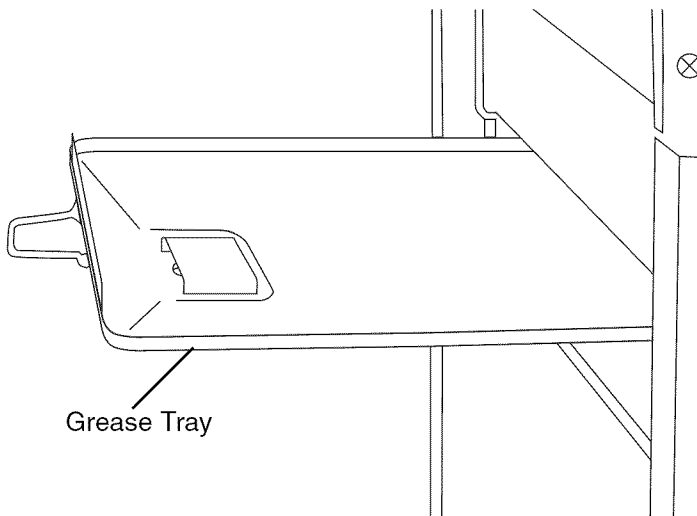
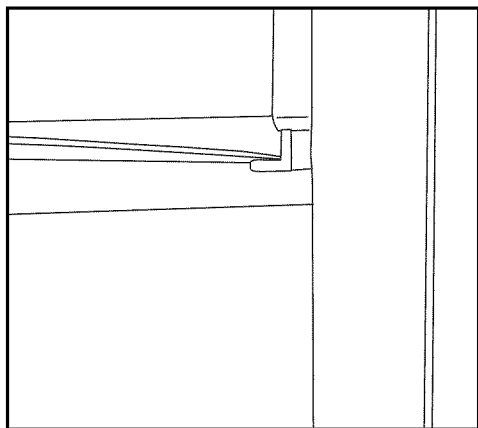

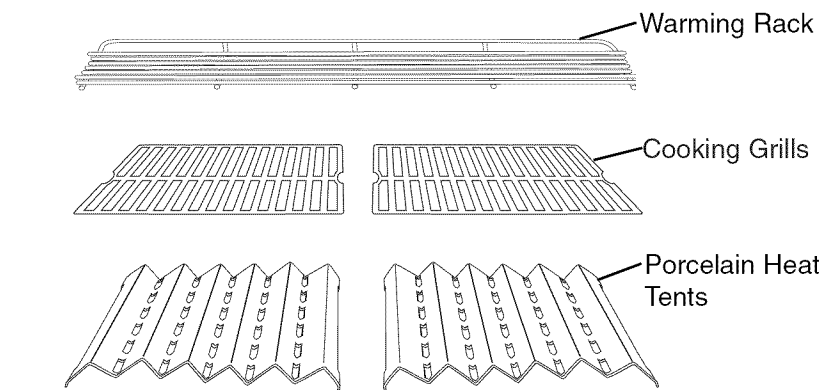

Step 15

Place the porcelain coated heat tents on lower level of grill body assembly directly above burners.

Step 16

Place porcelain cast iron cooking grills on support ribs directly above porcelain heat tents.

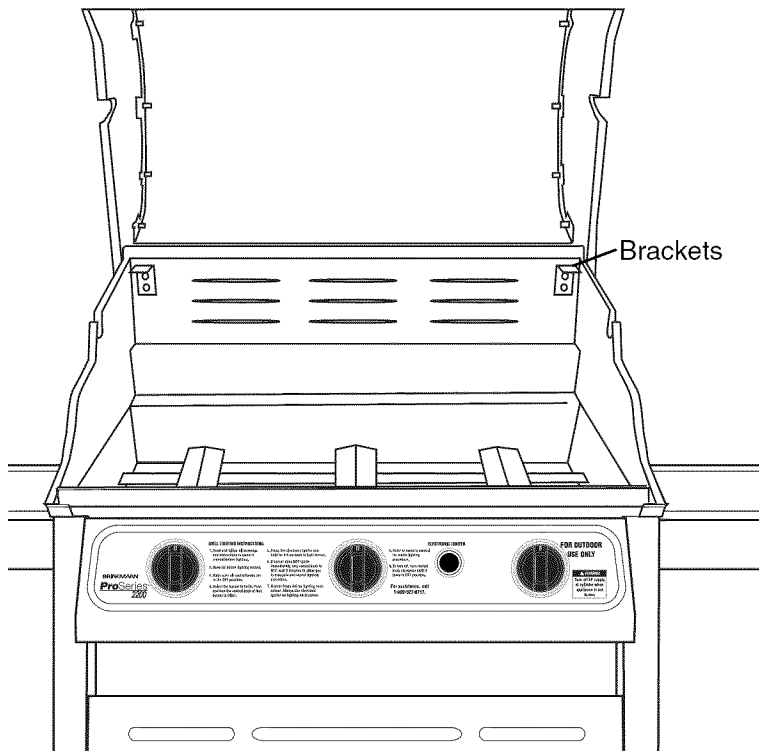

Step 17

Place warming rack in brackets so that it sits above the cooking grills.

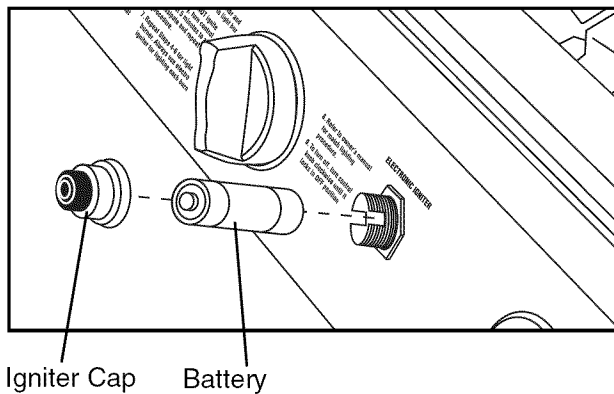

Step 18

Remove igniter cap and insert battery with positive end of battery toward igniter cap. Replace igniter cap and make sure the igniter is working properly.

ProSeries 2200 (Assembled)

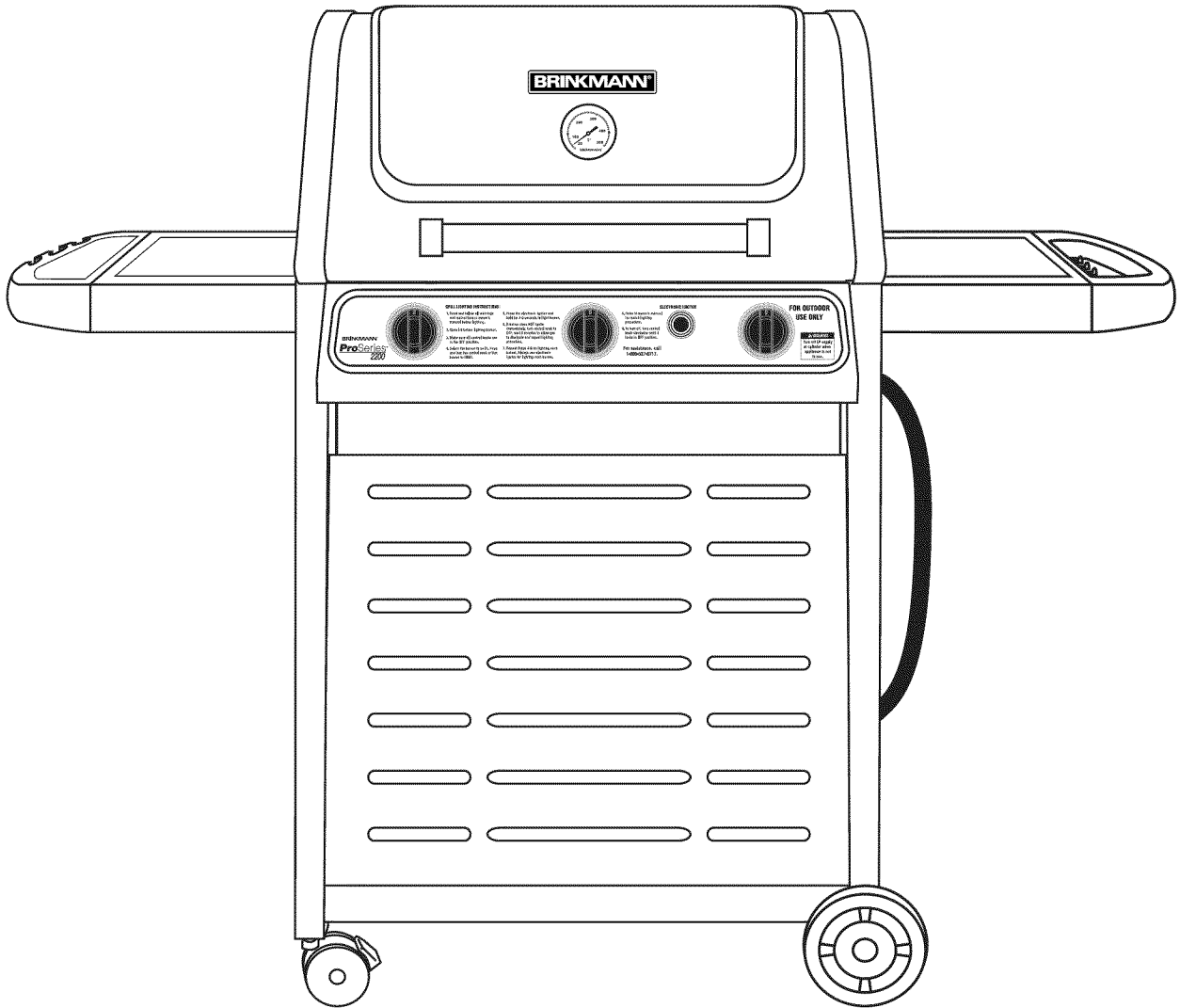

ACCESSORIES

RIB RACK

Chrome-plated rack can greatly increase the cooking capacity of your grill. Holds ribs, chicken halves, potatoes and corn vertically to triple cooking capacity. Allows smoke, steam and heat to penetrate food evenly.

812-3310-0

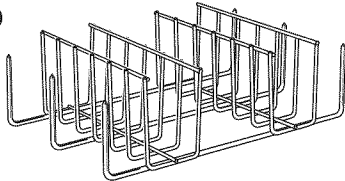

PROFESSIONAL SHISH-KABOB SKEWERS

These heavy-duty, 18" shish-kabob skewers are extra-long for fabulous restaurant style kabobs. Made of rust resistant stainless steel to last for years.

SET OF 12
812-2904-0

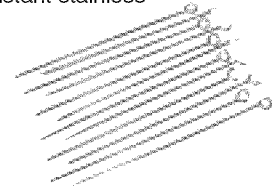

MEATLOAF BASKET

The unique basket weave prevents meatloaf from falling through the grill while allowing smoke, steam and heat to flow into the food. Also, provides a convenient method for lifting your meatloaf in and out of the smoker.

400-0073-0

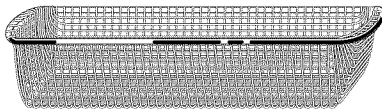

SMOKER BASKET

The unique basket weave prevents food from falling through the grill while allowing smoke, steam and heat to flow into the food. Great for fish, shrimp, vegetables and hors d'oeuvres.

812-3333-0

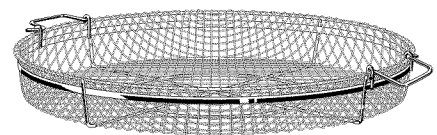

CHICKEN AND TURKEY RACKS

These chromed steel racks hold chicken, cornish hen, duck or turkey upright and are ideal for smoking, grilling or oven roasting poultry. The rack allows the meat to cook from the inside as well as from the outside. This speeds up cooking time, seals in flavorful juices and promotes even browning of skin. It's a low fat way to cook poultry because excess fat drips off the meat. When oven roasting, place poultry on rack in a shallow pan of water to steam baste to tender perfection. When grilling or smoking, simply place poultry on rack atop the grill. Makes carving easier, too.

CHICKEN RACKS (SET OF TWO)

885-9015-0

TURKEY RACK

885-9025-0

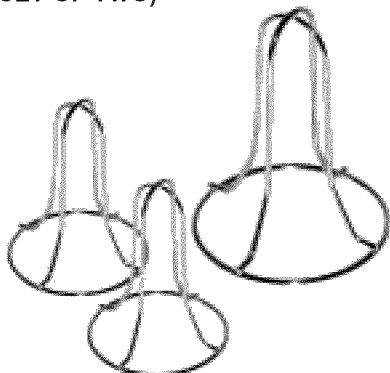

COMMERCIAL-QUALITY MEAT THERMOMETER

An essential tool when cooking all types of meat. Get perfectly smoked roasts, briskets and turkeys without cutting into the meat. Commercial-quality thermostat features an easy-to-read 2 3/4" wide dial with a 5 1/4" stem. Features Fahrenheit and Centigrade readings and National Livestock and Meat Board recommended temperatures. Also features the newly recommended 170°F internal temperature for fresh pork. Stainless steel construction and dishwasher safe.

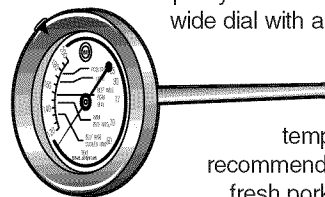

812-4100-0

ACCESSORIES

2-GALLON PAN & BASKET SET

Restaurant-style aluminum fry pan with nickel plated wire straining basket is an essential tool for frying fish, chicken, french fries, onion rings and more. Strainer basket holder helps drain excess oil. Use outdoors with the Brinkmann Backyard Kitchen and avoid the mess and odor of frying indoors.

815-3610-0

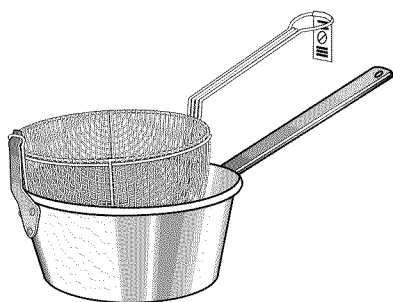

THE ULTIMATE 5-PIECE BBQ TOOL SET

You'll be the envy of your fellow outdoor chefs with this ultimate BBQ tool set. It's sleek ergonomic design combined with durable, heavy-gauge stainless steel construction is truly impressive. Extra-wide, polished utensils provide precise handling and control when flipping, basting and turning your food on the grill. Beautifully crafted, smooth rosewood handles are oval-shaped to fit comfortably in your hand and are extra-long to keep your hands safely away from the fire. The five-piece set includes tongs, spatula, fork, basting brush, and a grill brush. Includes leather hanging straps for convenient storage.

812-5045-0

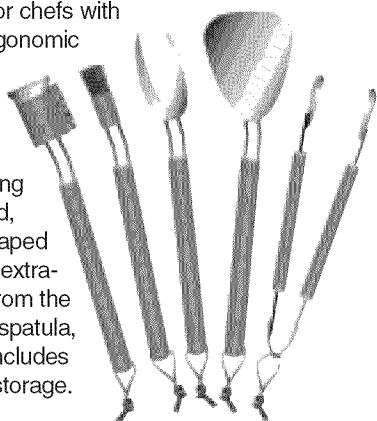

MULTI-PURPOSE SPATULA

If you could have only one BBQ tool, this multi-purpose spatula is it! Aside from being a great spatula, it features a serrated edge for cutting, a bottle opener, and special grooved edges for cleaning grills. Made of heavy-gauge stainless steel to last for years. Beautiful rosewood handles are slotted and riveted for maximum strength and durability. Includes leather hanging straps for convenient storage.

812-5047-0



SMOKE'N SPICE SEASONING

These custom blended spices are a delicious marinade seasoning for smoke cooking and grilling. Contains no MSG. Available in red and white meat varieties in a money-saving 2-pack.

812-3322-0



STAINLESS STEEL WOOD CHIP SMOKING BOX

Rugged stainless steel smoking box allows wood chips to burn longer for richer smoke flavor and provides easy cleanup of ashes. Ideal for charcoal, electric, gas smokers and grills.

812-3311-0

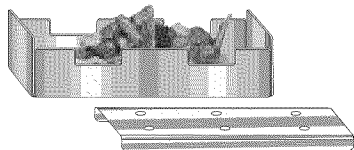

MARINADE INJECTOR

This quick and easy marinade injector marinates meat in 5 minutes, not hours! Mix your favorite marinade and spices into a liquid and inject into turkey, roast, chicken or steak for a naturally tenderized and flavorful delight. The reusable Marinade Injector includes a heavy-duty stainless steel needle and heavy-gauge plastic syringe to last for years.

812-5059-0



LOOK FOR THESE AND OTHER BRINKMANN ACCESSORIES AT YOUR LOCAL RETAILER WHERE SMOKERS ARE SOLD, OR ORDER DIRECT BY CALLING

1-800-468-5252.

WARRANTY

The Brinkmann Corporation warrants to the original purchaser that the Brinkmann ProSeries 2200™ is free from defects due to workmanship or materials for:

Die cast parts - Lifetime
Electronic ignition and burners - 10 Years
Remaining parts - 1 Year

The Brinkmann Corporation's obligations under this warranty are limited to the following guidelines:

- This warranty does not cover grills that have been altered or damaged due to: normal wear, rust, abuse, improper maintenance, improper use, disassembly of parts and/or attempted repair by anyone other than an authorized employee of The Brinkmann Corporation.
- This warranty does not cover surface scratches, rust or heat damage to the finish, which is considered normal wear.
- The Brinkmann Corporation may elect to repair or replace damaged units covered by the terms of this warranty.
- This warranty extends to the original purchaser only and is not transferable or assignable to subsequent purchasers.

The Brinkmann Corporation requires reasonable proof of purchase. Therefore, we strongly recommend that you retain your sales receipt or invoice. To obtain replacement parts for your Brinkmann ProSeries 2200™ under the terms of this warranty, please call Customer Service Department at 1-800-527-0717. **A receipt will be required. The Brinkmann Corporation will not be responsible for any grills forwarded to us without prior authorization.** Brinkmann ProSeries 2200™ must be returned to the original place of purchase for replacement of the unit.

EXCEPT AS ABOVE STATED, THE BRINKMANN CORPORATION MAKES NO OTHER EXPRESS WARRANTY.

THE IMPLIED WARRANTIES OF MERCHANTABILITY AND FITNESS FOR A PARTICULAR PURPOSE ARE LIMITED IN DURATION TO THOSE LISTED ABOVE FROM THE DATE OF PURCHASE. SOME STATES DO NOT ALLOW LIMITATIONS ON HOW LONG AN IMPLIED WARRANTY LASTS, SO THE ABOVE LIMITATION MAY NOT APPLY TO YOU.

ANY LIABILITY FOR INDIRECT, INCIDENTAL OR CONSEQUENTIAL DAMAGES ARISING FROM THE FAILURE OF THE BRINKMANN PROSERIES 2200™ TO COMPLY WITH THIS WARRANTY OR ANY IMPLIED WARRANTY IS EXCLUDED. CUSTOMER ACKNOWLEDGES THAT THE PURCHASE PRICE CHARGED IS BASED UPON THE LIMITATIONS CONTAINED IN THE WARRANTY SET OUT ABOVE. SOME STATES DO NOT ALLOW THE EXCLUSION OR LIMITATION OF INCIDENTAL OR CONSEQUENTIAL DAMAGES, SO THE ABOVE LIMITATION OR EXCLUSION MAY NOT APPLY TO YOU. THIS WARRANTY GIVES YOU SPECIFIC LEGAL RIGHTS, AND YOU MAY ALSO HAVE OTHER RIGHTS WHICH VARY FROM STATE TO STATE.