

# Operator's Manual



# CX SERIES

Electric Start

## SNOW THROWER

Model No. 247.883971

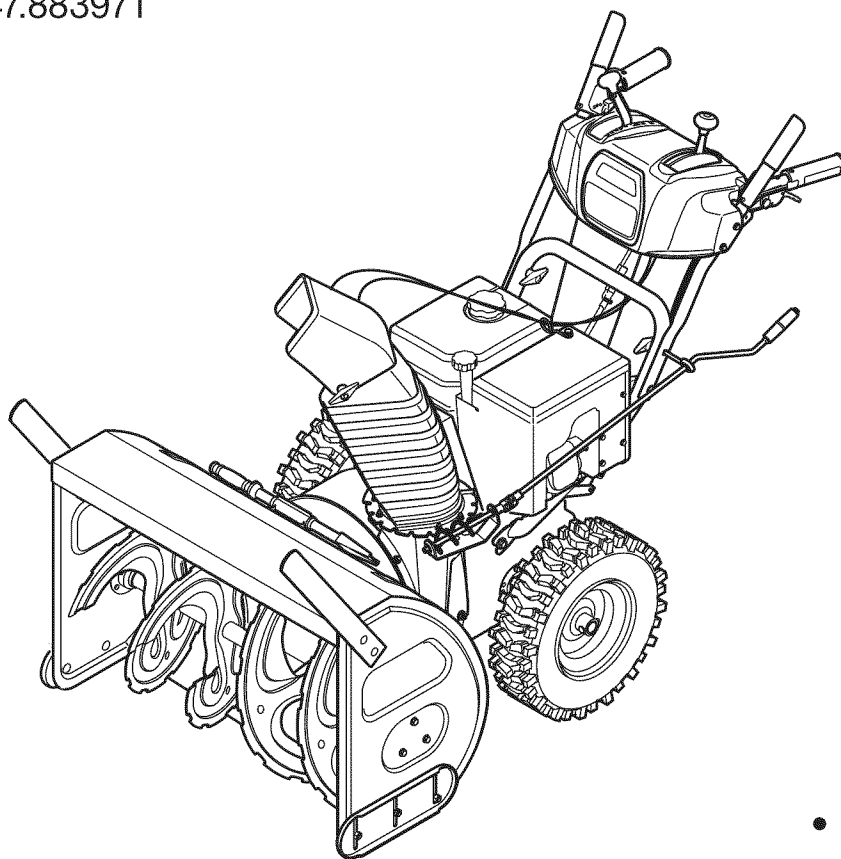

**CAUTION:** Before using this product, read this manual and follow all safety rules and operating instructions.

- SAFETY
- ASSEMBLY
- OPERATION
- MAINTENANCE
- PARTS LIST
- ESPAÑOL

Sears Brands Management Corporation, Hoffman Estates, IL 60179, U.S.A.

Visit our website: [www.craftsman.com](http://www.craftsman.com)

Form No. 769-08168B  
(June 17, 2013)

# TABLE OF CONTENTS

Warranty Statement.....	Page 2	Troubleshooting .....	Page 27
Safe Operation Practices.....	Page 3	Parts List.....	Page 28
Assembly .....	Page 7	Repair Protection Agreement .....	Page 47
Operation .....	Page 12	Español .....	Page 48
Service and Maintenance.....	Page 17	Service Numbers .....	Back Cover
Off-Season Storage.....	Page 25		

# WARRANTY STATEMENT

## CRAFTSMAN CX TWO YEAR FULL WARRANTY

FOR TWO YEARS from the date of purchase, this product is warranted against any defects in material or workmanship. A defective product will receive free repair or replacement if repair is unavailable.

For warranty coverage details to obtain free repair or replacement, visit the web site: [www.craftsman.com](http://www.craftsman.com)

**This warranty covers ONLY defects in material and workmanship. Warranty coverage does NOT include:**

- Expendable items that can wear out from normal use within the warranty period, including but not limited to augers, auger paddles, drift cutters, skid shoes, shave plate, shear pins, spark plug, air cleaner, belts, and oil filter.
- Standard maintenance servicing, oil changes, or tune-ups.
- Tire replacement or repair caused by punctures from outside objects, such as nails, thorns, stumps, or glass.
- Tire or wheel replacement or repair resulting from normal wear, accident, or improper operation or maintenance.
- Repairs necessary because of operator abuse, including but not limited to damage caused by over-speeding the engine, or from impacting objects that bend the frame, auger shaft, etc.
- Repairs necessary because of operator negligence, including but not limited to, electrical and mechanical damage caused by improper storage, failure to use the proper grade and amount of engine oil, or failure to maintain the equipment according to the instructions contained in the operator's manual.
- Engine (fuel system) cleaning or repairs caused by fuel determined to be contaminated or oxidized (stale). In general, fuel should be used within 30 days of its purchase date.
- Normal deterioration and wear of the exterior finishes, or product label replacement.

This warranty is void if this product is ever used while providing commercial services or if rented to another person.

This warranty gives you specific legal rights, and you may also have other rights which vary from state to state.

Sears Brands Management Corporation, Hoffman Estates, IL 60179

## PRODUCT SPECIFICATIONS

Engine Oil Type:	5W-30
Engine Oil Capacity:	37 ounces
Fuel Capacity:	Approx. 5 Quarts
Spark Plug:	F6RTC (951-10292)
Spark Plug Gap:	.020" to .030"

## MODEL NUMBER

Model Number .....

Serial Number .....

Date of Purchase .....

Record the model number, serial number  
and date of purchase above

# SAFETY INSTRUCTIONS

## WARNING

This symbol points out important safety instructions which, if not followed, could endanger the personal safety and/or property of yourself and others. Read and follow all instructions in this manual before attempting to operate this machine. Failure to comply with these instructions may result in personal injury. When you see this symbol, **HEED ITS WARNING!**

## WARNING

### CALIFORNIA PROPOSITION 65

Engine Exhaust, some of its constituents, and certain vehicle components contain or emit chemicals known to State of California to cause cancer and birth defects or other reproductive harm.

## DANGER

This machine was built to be operated according to the safe operation practices in this manual. As with any type of power equipment, carelessness or error on the part of the operator can result in serious injury. This machine is capable of amputating fingers, hands, toes and feet and throwing debris. Failure to observe the following safety instructions could result in serious injury or death.

## WARNING

**Your Responsibility**—Restrict the use of this power machine to persons who read, understand and follow the warnings and instructions in this manual and on the machine.

**SAVE THESE INSTRUCTIONS!**

## TRAINING

- Read, understand, and follow all instructions on the machine and in the manual(s) before attempting to assemble and operate. Failure to do so can result in serious injury to the operator and/or bystanders. Keep this manual in a safe place for future and regular reference and for ordering replacement parts.
- Be familiar with all controls and their proper operation. Know how to stop the machine and disengage them quickly.
- Never allow children under 14 years of age to operate this machine. Children 14 and over should read and understand the instructions and safe operation practices in this manual and on the machine and be trained and supervised by an adult.
- Never allow adults to operate this machine without proper instruction.
- Thrown objects can cause serious personal injury. Plan your snow-throwing pattern to avoid discharge of material toward roads, bystanders and the like.
- Keep bystanders, pets and children at least 75 feet from the machine while it is in operation. Stop machine if anyone enters the area.
- Exercise caution to avoid slipping or falling, especially when operating in reverse.

## PREPARATION

- Thoroughly inspect the area where the equipment is to be used. Remove all doormats, newspapers, sleds, boards, wires and other foreign objects, which could be tripped over or thrown by the auger/impeller.
- Always wear safety glasses or eye shields during operation and while performing an adjustment or repair to protect your eyes. Thrown objects which ricochet can cause serious injury to the eyes.
- Do not operate without wearing adequate winter outer garments. Do not wear jewelry, long scarves or other loose clothing, which could become entangled in moving parts. Wear footwear which will improve footing on slippery surfaces.
- Use a grounded three-wire extension cord and receptacle for all machines with electric start engines.

- Disengage all control levers before starting the engine.
- Adjust collector housing height to clear gravel or crushed rock surfaces.
- Never attempt to make any adjustments while engine is running, except where specifically recommended in the operator's manual.
- Let engine and machine adjust to outdoor temperature before starting to clear snow.

### Safe Handling of Gasoline:

To avoid personal injury or property damage use extreme care in handling gasoline. Gasoline is extremely flammable and the vapors are explosive. Serious personal injury can occur when gasoline is spilled on yourself or your clothes which can ignite. Wash your skin and change clothes immediately.

- Use only an approved gasoline container.
- Never fill containers inside a vehicle or on a truck or trailer bed with a plastic liner. Always place containers on the ground away from your vehicle before filling.
- When practical, remove gas-powered equipment from the truck or trailer and refuel it on the ground. If this is not possible, then refuel such equipment on a trailer with a portable container, rather than from a gasoline dispenser nozzle.
- Keep the nozzle in contact with the rim of the fuel tank or container opening at all times until fueling is complete. Do not use a nozzle lock-open device.
- Extinguish all cigarettes, cigars, pipes and other sources of ignition.
- Never fuel machine indoors.
- Never remove gas cap or add fuel while the engine is hot or running. Allow engine to cool at least two minutes before refueling.
- Never over fill fuel tank. Fill tank to no more than ½ inch below bottom of filler neck to allow space for fuel expansion.
- Replace gasoline cap and tighten securely.
- If gasoline is spilled, wipe it off the engine and equipment. Move unit to another area. Wait 5 minutes before starting the engine.

# SAFETY INSTRUCTIONS

- To reduce fire hazards, keep machine free of grass, leaves, or other debris build-up. Clean up oil or fuel spillage and remove any fuel soaked debris.
- Never store the machine or fuel container inside where there is an open flame, spark or pilot light as on a water heater, space heater, furnace, clothes dryer or other gas appliances.

## OPERATION

- Do not put hands or feet near rotating parts, in the auger/impeller housing or chute assembly. Contact with the rotating parts can amputate hands and feet.
- The auger/impeller control lever is a safety device. Never bypass its operation. Doing so makes the machine unsafe and may cause personal injury.
- The control levers must operate easily in both directions and automatically return to the disengaged position when released.
- Never operate with a missing or damaged chute assembly. Keep all safety devices in place and working.
- Never run an engine indoors or in a poorly ventilated area. Engine exhaust contains carbon monoxide, an odorless and deadly gas.
- Do not operate machine while under the influence of alcohol or drugs.
- Muffler and engine become hot and can cause a burn. Do not touch. Keep children away.
- Exercise extreme caution when operating on or crossing gravel surfaces. Stay alert for hidden hazards or traffic.
- Exercise caution when changing direction and while operating on slopes. Do not operate on steep slopes.
- Plan your snow-throwing pattern to avoid discharge towards windows, walls, cars etc. Thus, avoiding possible property damage or personal injury caused by a ricochet.
- Never direct discharge at children, bystanders and pets or allow anyone in front of the machine.
- Do not overload machine capacity by attempting to clear snow at too fast of a rate.
- Never operate this machine without good visibility or light. Always be sure of your footing and keep a firm hold on the handles. Walk, never run.
- Disengage power to the auger/impeller when transporting or not in use.
- Never operate machine at high transport speeds on slippery surfaces. Look down and behind and use care when backing up.
- If the machine should start to vibrate abnormally, stop the engine, disconnect the spark plug wire and ground it against the engine. Inspect thoroughly for damage. Repair any damage before starting and operating.
- Disengage all control levers and stop engine before you leave the operating position (behind the handles). Wait until the auger/impeller comes to a complete stop before unlogging the chute assembly, making any adjustments, or inspections.
- Never put your hand in the discharge or collector openings. Do not unlog chute assembly while engine is running. Shut off engine and remain behind handles until all moving parts have stopped before unlogging.

- Use only attachments and accessories approved by the manufacturer (e.g. wheel weights, tire chains, cabs etc.).
- When starting engine, pull cord slowly until resistance is felt, then pull rapidly. Rapid retraction of starter cord (kickback) will pull hand and arm toward engine faster than you can let go. Broken bones, fractures, bruises or sprains could result.
- If situations occur which are not covered in this manual, use care and good judgment.

## CLEARING A CLOGGED DISCHARGE CHUTE

Hand contact with the rotating impeller inside the discharge chute is the most common cause of injury associated with snow throwers. Never use your hand to clean out the discharge chute.

To clear the chute:

- a. SHUT THE ENGINE OFF!
- b. Wait 10 seconds to be sure the impeller blades have stopped rotating.
- c. Always use a clean-out tool, not your hands.

## MAINTENANCE & STORAGE

- Never tamper with safety devices. Check their proper operation regularly. Refer to the maintenance and adjustment sections of this manual.
- Before cleaning, repairing, or inspecting machine disengage all control levers and stop the engine. Wait until the auger/impeller come to a complete stop. Disconnect the spark plug wire and ground against the engine to prevent unintended starting.
- Check bolts and screws for proper tightness at frequent intervals to keep the machine in safe working condition. Also, visually inspect machine for any damage.
- Do not change the engine governor setting or over-speed the engine. The governor controls the maximum safe operating speed of the engine.
- Snow thrower shave plates and skid shoes are subject to wear and damage. For your safety protection, frequently check all components and replace with original equipment manufacturer's (OEM) parts only as listed in the Parts pages of this operator's manual. Use of parts which do not meet the original equipment specifications may lead to improper performance and compromise safety!
- Check control levers periodically to verify they engage and disengage properly and adjust, if necessary. Refer to the adjustment section in this operator's manual for instructions.
- Maintain or replace safety and instruction labels, as necessary.
- Observe proper disposal laws and regulations for gas, oil, etc. to protect the environment.
- Prior to storing, run machine a few minutes to clear snow from machine and prevent freeze up of auger/impeller.
- Never store the machine or fuel container inside where there is an open flame, spark or pilot light such as a water heater, furnace, clothes dryer etc.
- Always refer to the operator's manual for proper instructions on off-season storage.



# SAFETY INSTRUCTIONS

- Check fuel line, tank, cap, and fittings frequently for cracks or leaks. Replace if necessary.
- Do not crank engine with spark plug removed.
- According to the Consumer Products Safety Commission (CPSC) and the U.S. Environmental Protection Agency (EPA), this product has an *Average Useful Life* of seven (7) years, or 60 hours of operation. At the end of the *Average Useful Life* have the machine inspected annually by an authorized service dealer to ensure that all mechanical and safety systems are working properly and not worn excessively. Failure to do so can result in accidents, injuries or death.

## DO NOT MODIFY ENGINE

To avoid serious injury or death, do not modify engine in any way. Tampering with the governor setting can lead to a runaway engine and cause it to operate at unsafe speeds. Never tamper with factory setting of engine governor.

## NOTICE REGARDING EMISSIONS

Engines which are certified to comply with California and federal EPA emission regulations for SORE (Small Off Road Equipment) are certified to operate on regular unleaded gasoline, and may include the following emission control systems: Engine Modification (EM), Oxidizing Catalyst (OC), Secondary Air Injection (SAI) and Three Way Catalyst (TWC) if so equipped.

## SPARK ARRESTOR

### WARNING

This machine is equipped with an internal combustion engine and should not be used on or near any unimproved forest-covered, brushcovered or grass-covered land unless the engine's exhaust system is equipped with a spark arrestor meeting applicable local or state laws (if any).







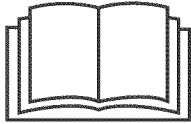

If a spark arrestor is used, it should be maintained in effective working order by the operator. In the State of California the above is required by law (Section 4442 of the California Public Resources Code). Other states may have similar laws. Federal laws apply on federal lands.

A spark arrestor for the muffler is available through your nearest Sears Parts and Repair Service Center.

# SAFETY INSTRUCTIONS

## SAFETY SYMBOLS

This page depicts and describes safety symbols that may appear on this product. Read, understand, and follow all instructions on the machine before attempting to assemble and operate.

Symbol	Description
	<b>READ THE OPERATOR'S MANUAL(S)</b> Read, understand, and follow all instructions in the manual(s) before attempting to assemble and operate
	<b>WARNING— ROTATING BLADES</b> Keep hands out of inlet and discharge openings while machine is running. There are rotating blades inside
	<b>WARNING— ROTATING BLADES</b> Keep hands out of inlet and discharge openings while machine is running. There are rotating blades inside
	<b>WARNING— ROTATING AUGER</b> Do not put hands or feet near rotating parts, in the auger/impeller housing or chute assembly. Contact with the rotating parts can amputate hands and feet.
	<b>WARNING—THROWN OBJECTS</b> This machine may pick up and throw and objects which can cause serious personal injury.
	<b>WARNING— GASOLINE IS FLAMMABLE</b> Allow the engine to cool at least two minutes before refueling.
	<b>WARNING— CARBON MONOXIDE</b> Never run an engine indoors or in a poorly ventilated area. Engine exhaust contains carbon monoxide, an odorless and deadly gas.
	<b>WARNING— ELECTRICAL SHOCK</b> Do not use the engine's electric starter in the rain
	<b>WARNING— HOT SURFACE</b> Engine parts, especially the muffler, become extremely hot during operation. Allow engine and muffler to cool before touching.



**WARNING:** Your Responsibility—Restrict the use of this power machine to persons who read, understand and follow the warnings and instructions in this manual and on the machine.

**SAVE THESE INSTRUCTIONS!**

# ASSEMBLY

**NOTE:** References to right or left side of the snow thrower are determined from the operating position looking forward to the front of the machine.

## Removing From Crate

1. Remove screws from the bottom of the crate securing the sides, and ends of the shipping crate.
2. Lift off the top off of the crate and set out of the way of the assembly area.
3. Remove and discard plastic bag that covers unit.
4. Remove any loose parts included with unit (e.g., Operator's Manual, etc.).
5. Push down on the lower handle and pull unit back out of crate.
6. Make certain the crate has been completely emptied before discarding it.

## Assembly

1. Remove any packaging material from the upper handle.
2. Remove the lower plastic wing nut, belleville washer and carriage bolt from each side of the upper handle; then raise the upper handle assembly until it snaps over the lower handle. See Figure 1.

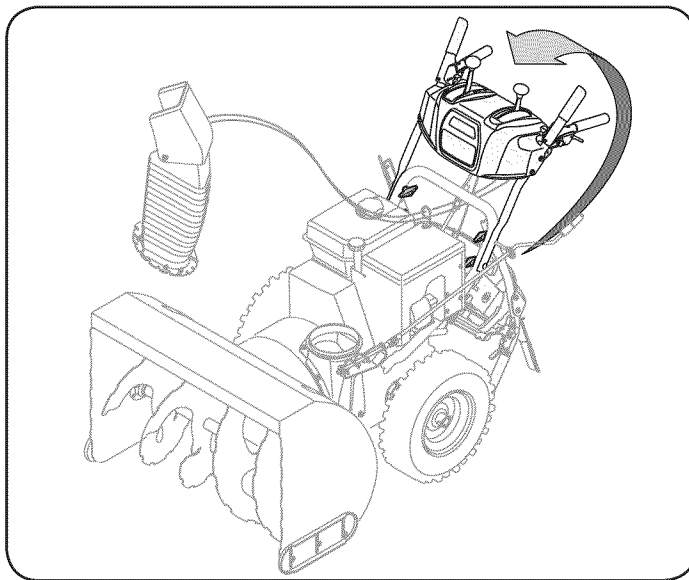

Figure 1

3. Looking beneath the handle panel, check that all of the cables (steering, auger, shift, and drive) are properly routed and not pinched or kinked. Make certain the springs at the lower end of the auger and drive cables are securely hooked into their respective actuator brackets.
4. Secure the upper handle and lower handle with the two wing nuts, belleville washers, and carriage bolts removed earlier. Tighten the two wing nuts already installed in the upper holes to firmly secure the upper handle and support tubes. See Figure 2.

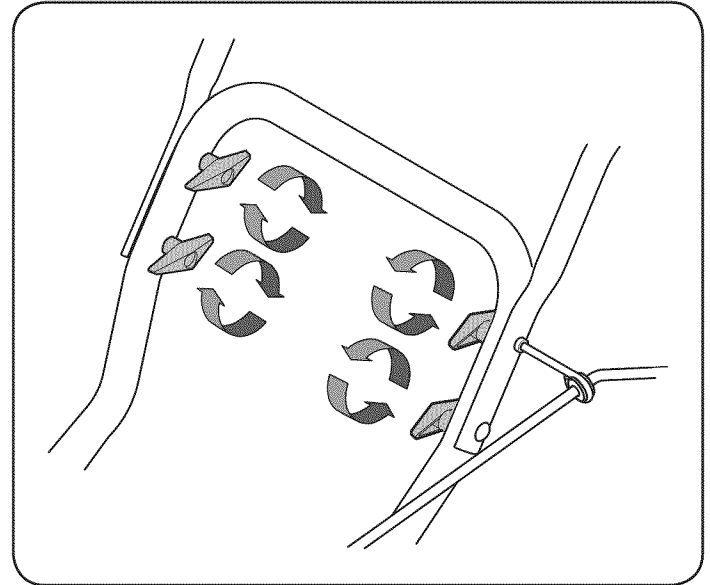

Figure 2

## Chute Assembly

1. Remove lock nuts and screws securing one of the flange keepers to the chute assembly. Loosen the fasteners of the other two flange keepers. See Figure 3.

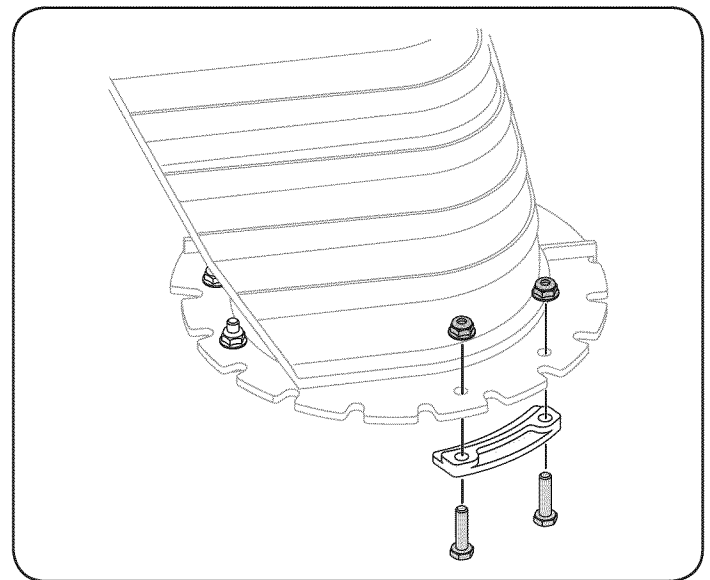

Figure 3

2. Loosen, but do not remove, the chute crank bracket in order to attach the chute assembly. See Figure 5.
3. Place chute assembly onto chute base as shown in Figure 4. Make sure that the chute notches engage with the spiral end of chute directional control, and the two flange keepers are beneath the flange on the chute base.
4. Secure flange keeper removed earlier with lock nuts and screws. Tighten down nuts securing the other two flange keepers. See Figure 5.

# ASSEMBLY

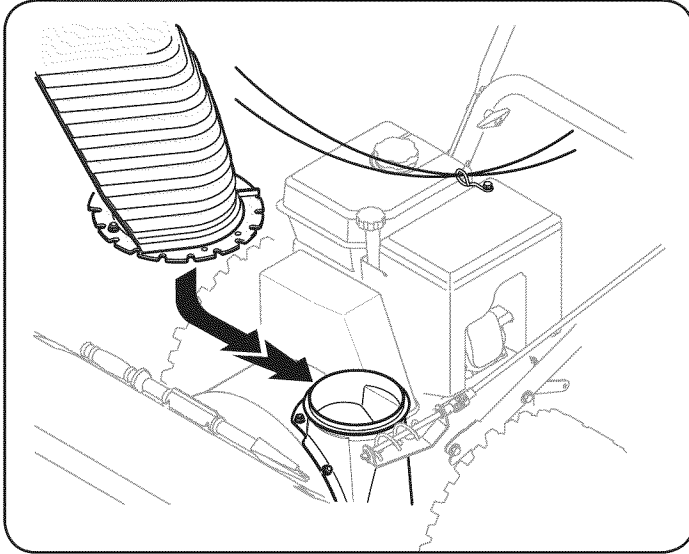

Figure 4

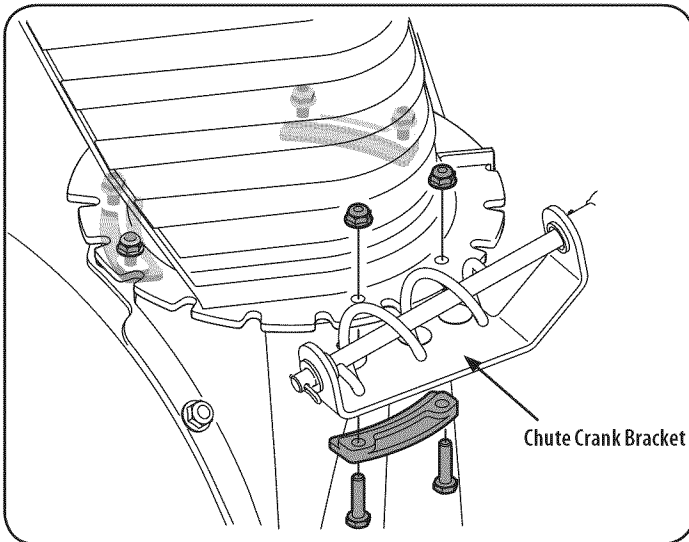

Figure 5

5. Re-tighten the hardware securing the chute crank bracket.
6. Check that the chute cables are properly routed through the cable guide on top of engine shroud. See Figure 6.

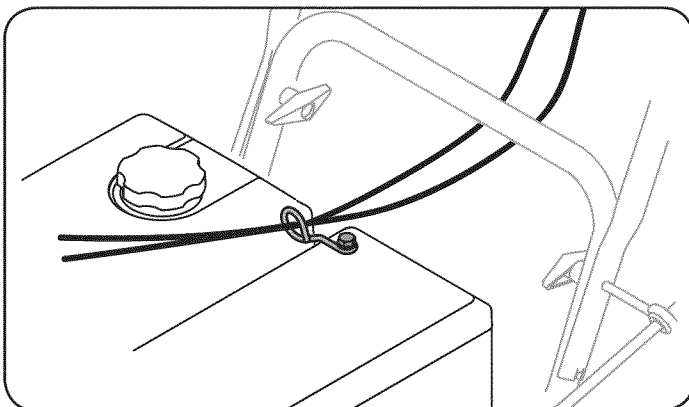

Figure 6

## Set-Up

### Shear Pins

A pair of replacement auger shear pins and bow tie cotter pins have been included with your snow thrower. They are stored in the holes provided in the plastic dash panel as seen in Figure 7. For information regarding replacing the shear pins, see Replacing Shear Pins in the Operation section of this manual.

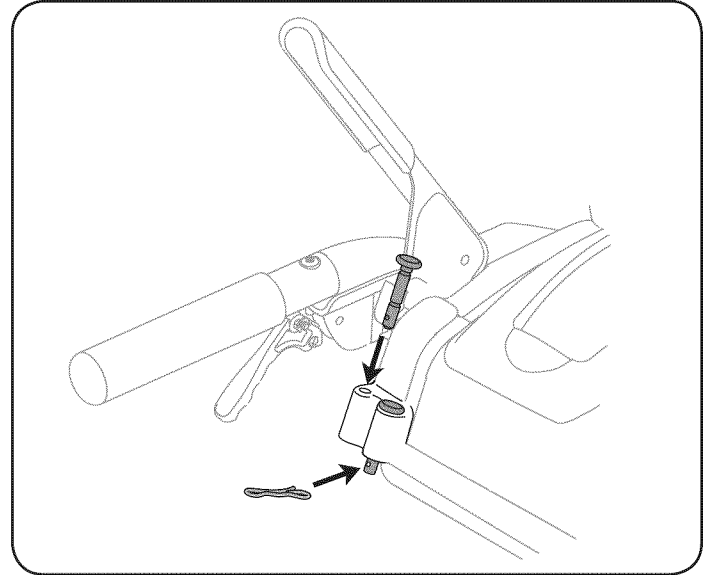

Figure 7

### Chute Clean-Out Tool

The chute clean-out tool is fastened to the top of the auger housing with a mounting clip and a cable tie at the factory. Cut the cable tie before operating the snow thrower. See Figure 8.

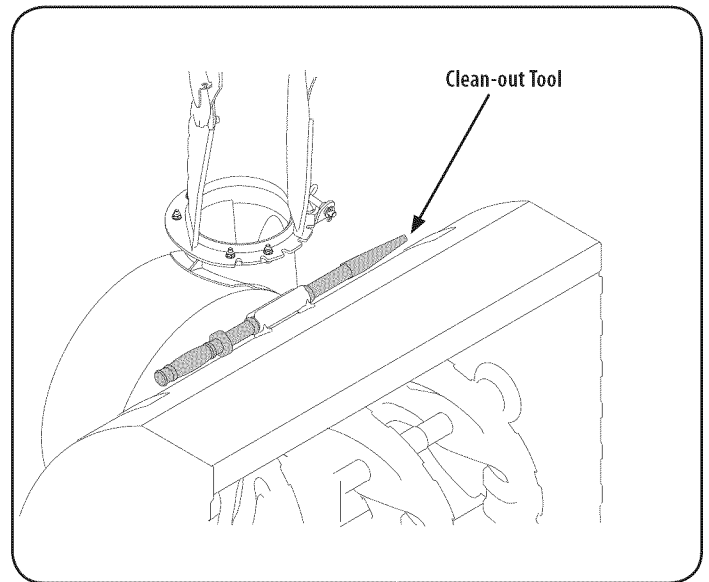

Figure 8

# ASSEMBLY

## Drift Cutters

The snow thrower drift cutters are mounted inverted at the factory for shipping purposes.

1. Remove the four wing knobs (two on each side) and carriage bolts. Place drift cutter in upright position and re-secure. See Figure 9.

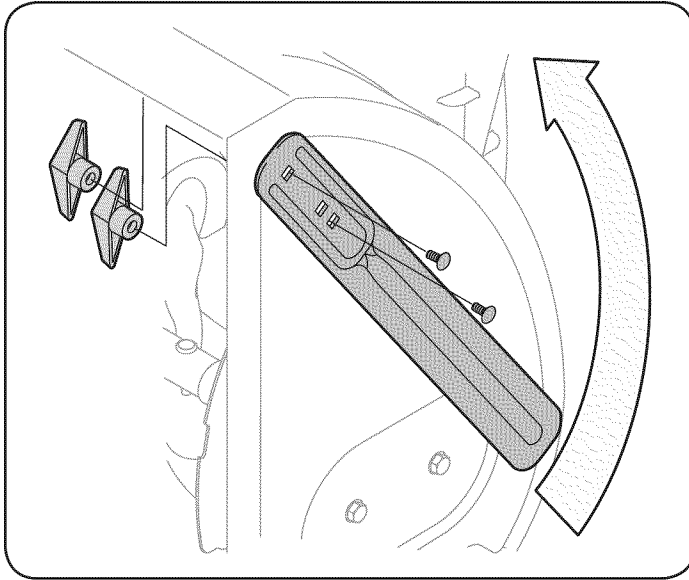

Figure 9

## Tire Pressure (Pneumatic Tires)

### ⚠ WARNING

Under any circumstance do not exceed manufacturer's recommended psi. Equal tire pressure should be maintained at all times. Excessive pressure when seating beads may cause tire/rim assembly to burst with force sufficient to cause serious injury. Refer to sidewall of tire for recommended pressure.

The tires can be over-inflated for shipping purposes. Check the tire pressure before operating the snow thrower. Refer to the tire side wall for manufacturer's recommended psi and deflate (or inflate) the tires as necessary.

**NOTE:** Equal tire pressure is to be maintained at all times for performance purposes.

## Fuel Recommendations

Use automotive gasoline (unleaded or low leaded to minimize combustion chamber deposits) with a minimum of 87 octane. Gasoline with up to 10% ethanol or 15% MTBE (Methyl Tertiary Butyl Ether) can be used. Never use an oil/gasoline mixture or dirty gasoline. Avoid getting dirt, dust, or water in the fuel tank. DO NOT use E85 gasoline.

- Refuel in a well-ventilated area with the engine stopped. Do not smoke or allow flames or sparks in the area where the engine is refueled or where gasoline is stored.
- Do not overfill the fuel tank. After refueling, make sure the tank cap is closed properly and securely.
- Be careful not to spill fuel when refueling. Spilled fuel or fuel vapor may ignite. If any fuel is spilled, make sure the area is dry before starting the engine.
- Avoid repeated or prolonged contact with skin or breathing of vapor.

## Adding Fuel

### ⚠ WARNING

Use extreme care when handling gasoline. Gasoline is extremely flammable and the vapors are explosive. Never fuel the machine indoors or while the engine is hot or running. Extinguish cigarettes, cigars, pipes and other sources of ignition.

### ⚠ WARNING

Always keep hands and feet clear of equipment moving parts. Do not use a pressurized starting fluid. Vapors are flammable.

1. Clean around fuel fill before removing cap to fuel.
2. A fuel level indicator is located in the fuel tank. Fill tank until fuel reaches the fuel level indicator, Figure 10. Be careful not to overfill.

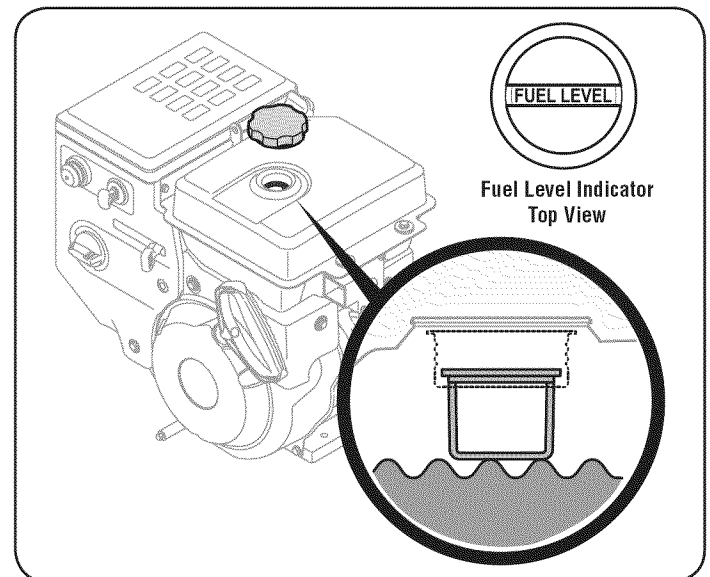

Figure 10

## Checking Oil Level

### ⚠ CAUTION

The engine is shipped with oil in the engine. You must, however, check the oil level prior to operating the snow thrower. Running the engine with insufficient oil can cause serious engine damage and void the engine warranty.

**NOTE:** Be sure to check the engine on a level surface with the engine stopped.

To avoid engine damage, it is important to:

- Check oil level before each use and every 5 operating hours when engine is warm. Check oil level more frequently during engine break-in.
  - Keep oil level between "H" and "L" marks on dipstick. See Figure 11.
  - Be sure oil fill cap/plug is tightened securely when checking.
1. Remove the oil filler cap/dipstick and wipe the dipstick clean. See Figure 11.
  2. Insert the cap/dipstick into the oil filler neck, and tighten the cap turning clockwise until cap is seated.

# ASSEMBLY

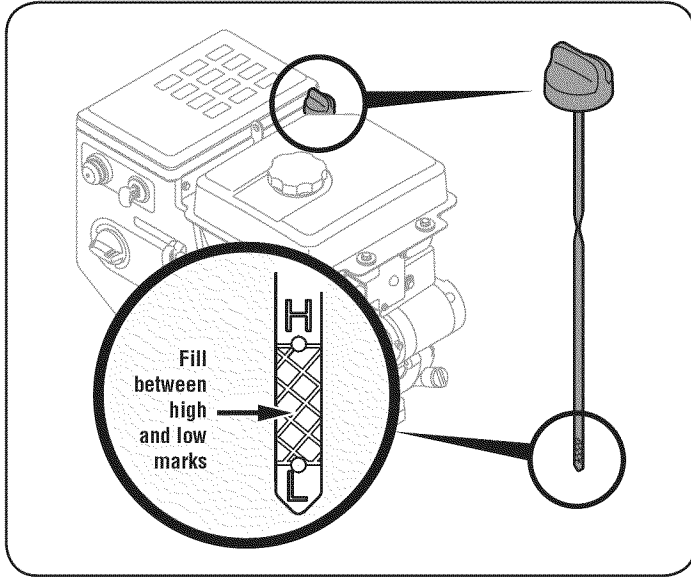

Figure 11

**NOTE:** On some engines, a threaded screw cap will be present instead of the quarter turn locking cap. In the instance of a threaded oil cap/dipstick, DO NOT screw the cap/dipstick in to check. Check the oil by resting the cap/dipstick on the threads, but not screwing it in.

3. Remove the oil filler cap/dipstick. If the level is low, slowly add oil until oil level registers between high (H) and low (L), Figure 11.
4. Replace and tighten cap/dipstick firmly before starting engine.

**NOTE:** Do not overfill. Overfilling with oil may cause smoking, hard starting, or spark plug fouling.

**NOTE:** DO NOT allow oil level to fall below the "L" mark on the dipstick. Doing so may result in equipment malfunctions or damage.

**NOTE:** To change the oil on your engine, see the Maintenance Section of the engine operator's manual included with the snow thrower.

## Adjustments

### Skid Shoes

The snow thrower skid shoes are adjusted upward at the factory for shipping purposes. Adjust them downward prior to operating the snow thrower.

### **CAUTION**

It is not recommended that you operate this snow thrower on gravel as it can easily pick up and throw loose gravel, causing personal injury or damage to the snow thrower and surrounding property.

For close snow removal on a smooth surface, adjust the skid shoes so that the shave plate on the bottom of the auger housing is just off the ground.

Adjust the skid shoes to a lower position to raise the shave plate off the ground when clearing uneven areas, such as a ribbon type driveway or a gravel driveway

**NOTE:** If you choose to operate the snow thrower on a gravel surface, keep the skid shoes in position for maximum clearance between the ground and the shave plate.

### To adjust the skid shoes:

1. Adjust skid shoes by loosening the six (three on each side) hex nuts and carriage bolts securing the skid shoes to the auger housing. Refer to Figure 12.

2. While observing the distance between the shave plate and the ground, adjust the skid shoes up or down to achieve the desired shave plate height. See Figure 12.
3. Make certain the entire bottom surface of skid shoes are against the ground to avoid uneven wear on the skid shoes; then tighten nuts and bolts securely.

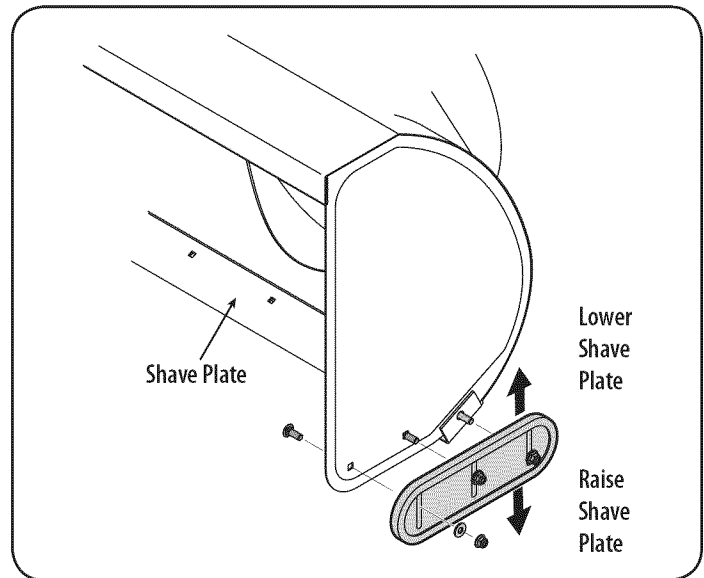

Figure 12

## Auger and Drive Control Cables

### **WARNING**

Prior to operating your snow thrower, carefully read and follow all instructions below. Perform all adjustments to verify your snow thrower is operating safely and properly.

### Testing Auger Drive Control

1. When the auger control is released and in the disengaged "up" position, the cable should have very little slack. It should NOT be tight. Refer to Figure 13.
2. In a well-ventilated area, start the snow thrower engine as instructed in the Operation section of this manual. Make sure the throttle is set in the FAST position.
3. While standing in the operator's position (behind the snow thrower), engage the auger.
4. Allow the auger to remain engaged for approximately ten (10) seconds before releasing the auger control. Repeat this several times.  
**NOTE:** When engaging the auger, you may hear a "chirp" sound. This is normal, it is the belt engaging the pulley. As the belt wears, this sound will not be heard when engaging the auger.
5. With the throttle control in the FAST (rabbit) position and the auger control in the disengaged "up" position, walk to the front of the machine.

# ASSEMBLY

6. Confirm that the auger has completely stopped rotating and shows NO signs of motion. If the auger shows ANY signs of rotating, immediately return to the operator's position and shut off the engine. Wait for ALL moving parts to stop before re-adjusting the auger control.

## Testing Drive Control & Speed Selector Lever

1. With the engine turned off, move the speed selector lever into sixth (6) position. Refer to Figure 13.
2. With the wheel drive control released, push the snow thrower forward, then pull it back. The machine should move freely.
3. Engage the drive control and attempt to move the machine both forward and back, resistance should be felt.
4. Move the speed selector lever into the fast reverse (R2) position and repeat the previous two steps.
5. If you experienced resistance rolling the unit, either when repositioning the speed selector lever from 6 to R2 or when attempting to move the machine with the drive control released, adjust the drive control immediately. See Adjusting Drive and Auger Controls.

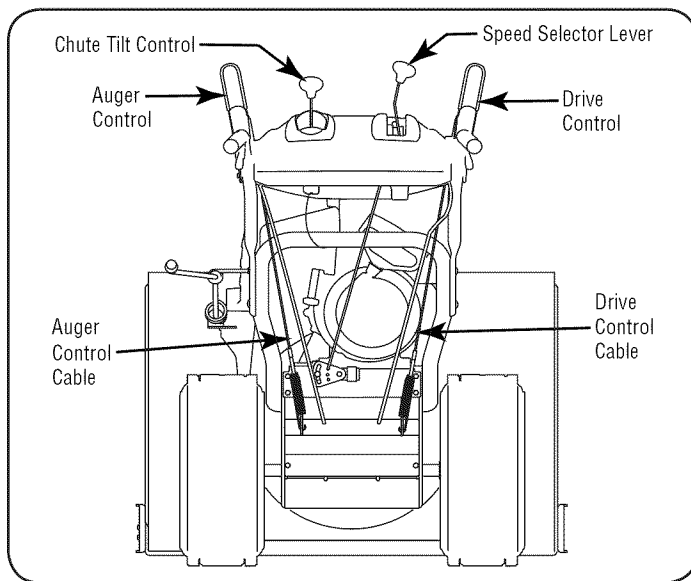

Figure 13

## Adjusting Drive and Auger Controls

1. From beneath the handle, pull downward on the appropriate cable and unhook the spring found on the end of the cable from its respective actuator bracket. Refer to Figure 14 and Figure 15.
2. Slide the spring up the cable to expose the cable coupler threads and lock nut. Refer to Figure 15.

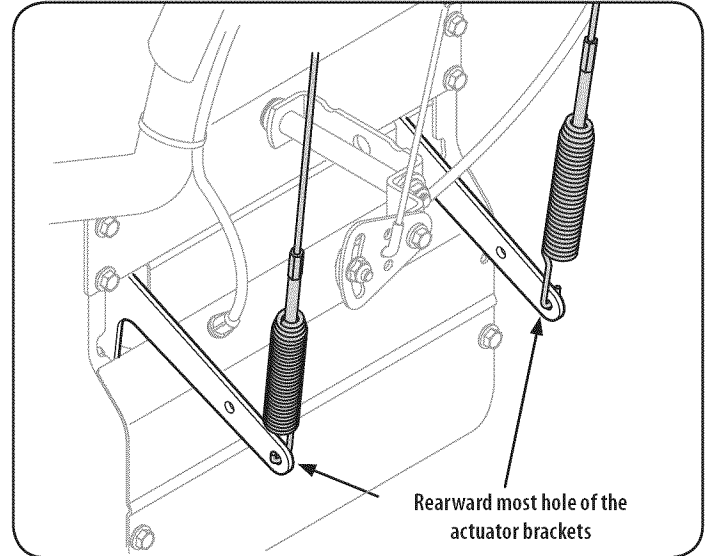

Figure 14

3. Adjust the lock nut as follows: If adjusting the drive cable, thread the lock nut outward (down the coupler) to lengthen the cable and allow the unit to move freely when the control is released. Thread the lock nut inward (up the coupler) to shorten the cable to reduce slippage and prevent the machine from being easily moved with the drive control engaged.

## ⚠ WARNING

**Do not over-tighten the cable. Over-tightening may prevent the auger shaft from disengaging and compromise the safety of the snow thrower.**

4. If adjusting the auger cable, thread the lock nut outwards towards end of thread to lengthen the cable as necessary to stop the auger shaft from turning when the control is released.
5. Securely hook each cable's spring into the appropriate hole of the respective actuator bracket. Both cables hook into the rearward-most hole in each bracket, as shown in Figure 14.
6. Repeat the wheel drive and auger control tests to verify proper adjustment. Repeat previous steps if necessary to attain proper adjustment of each cable.

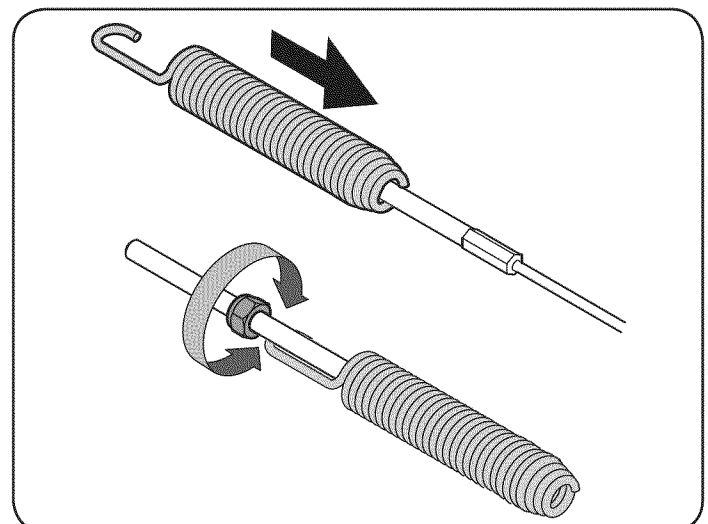

Figure 15

# OPERATION

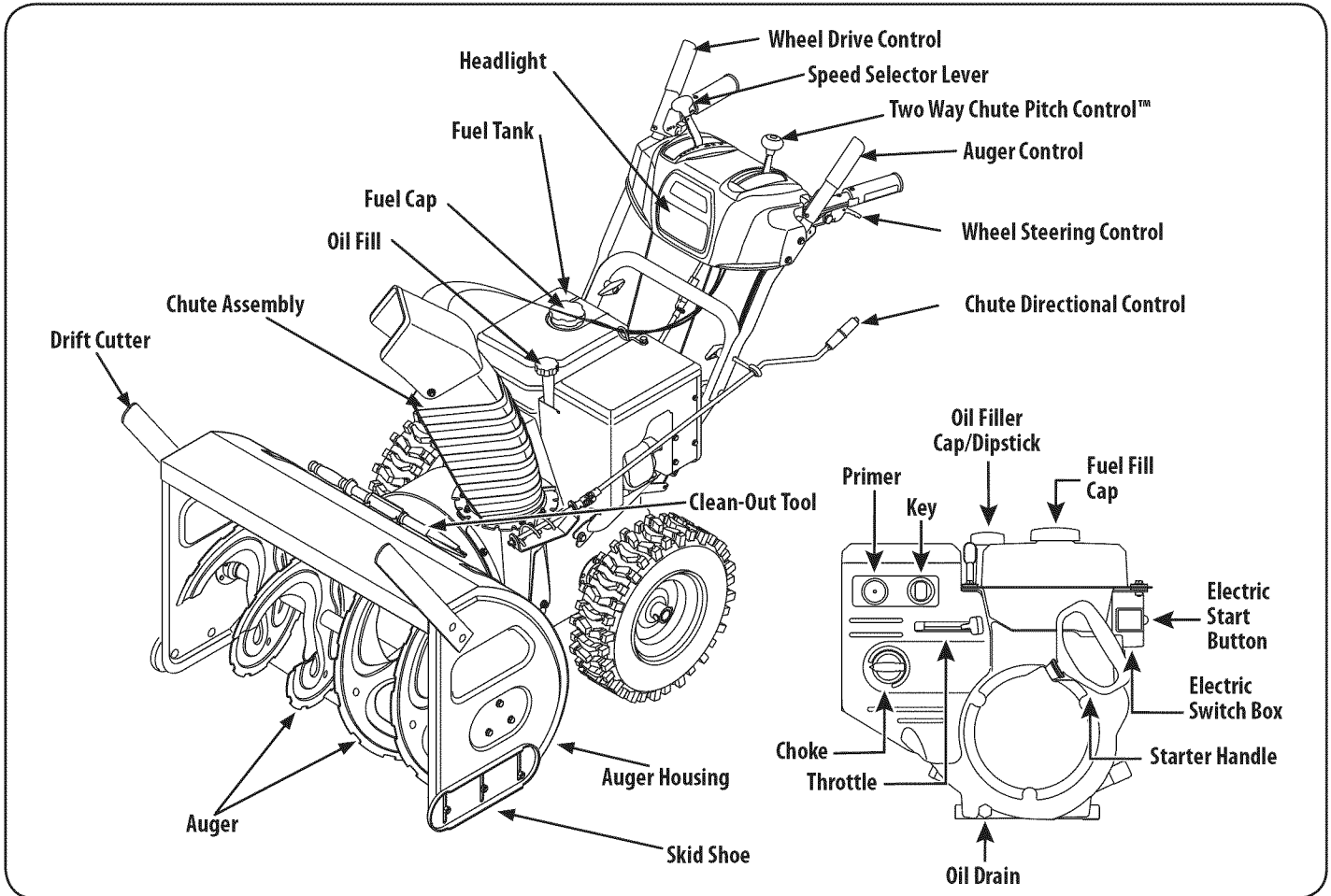

Figure 16

Snow thrower controls and features are described below and illustrated in Figure 16.

## Speed selector Lever

The speed selector lever is located in the right side of the handle panel and is used to determine ground speed and direction of travel.

### Forward

There are six forward (F) speeds. Position one (1) is the slowest and position six (6) is the fastest.

### Reverse

There are two reverse (R) speeds. One (R1) is the slower and two (R2) is the faster.

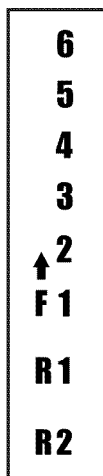

## Choke Control

The choke control is found on the rear of the engine and is activated by rotating the control counter-clockwise. Activating the choke control closes the choke plate on the carburetor and aids in starting the engine.

## Key

The key is a safety device. It must be fully inserted into the ignition in order for the engine to start. Remove the key when the snow thrower is not in use.

**IMPORTANT:** Do not turn the key in an attempt to start the engine. Doing so may cause it to break.



## Meets ANSI Safety Standards

Craftsman Snow Throwers conform to the safety standard of the American National Standards Institute (ANSI).



# OPERATION

## Throttle Control



The throttle control is located on the rear of the engine. It regulates the speed of the engine and will shut off the engine when moved into the STOP position.

## Primer

Pressing the primer forces fuel directly into the engine's carburetor to aid in starting a "Cold" engine, or restarting a warm engine.



## Oil Fill

Engine oil level can be checked and oil added through the oil fill.

## Oil Drain

Engine oil can be drained through the oil drain.

## Fuel Cap

Un-thread the gas cap to add gasoline to the fuel tank.

## Muffler

Engine exhaust exits the engine via the muffler.

## Electric Starter Outlet

Requires the use of a three-prong outdoor extension cord and a 120V power source/wall outlet.

## Recoil Starter Handle

This handle is used to manually start the engine.

## Electric Starter Button

Pressing the electric starter button engages the engine's electric starter when plugged into a 120V power source.

## Auger

When engaged, the auger blades rotate and draw snow into the auger housing.

## Chute Assembly

Snow drawn into the auger housing is discharged out the chute assembly.

## Drift Cutters

The drift cutters are designed for use in deep snow. Their use is optional for normal snow conditions. Maneuver the snow thrower so that the cutters penetrate a high standing snow drift to assist snow falling into the augers for throwing.

## Skid Shoes

Position the skid shoes based on surface conditions. Adjust upward for hard-packed snow. Adjust downward when operating on gravel or crushed rock surfaces.

## Auger Control

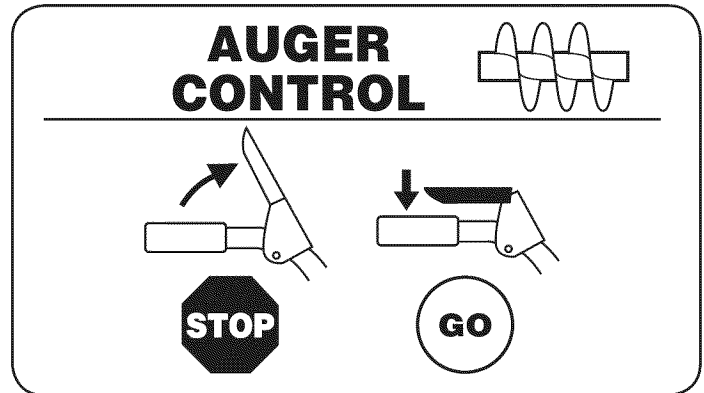

The auger control is located on the left handle. Squeeze the control grip against the handle to engage the auger and start snow throwing action. Release to stop.

## Drive Control / Auger Clutch Lock

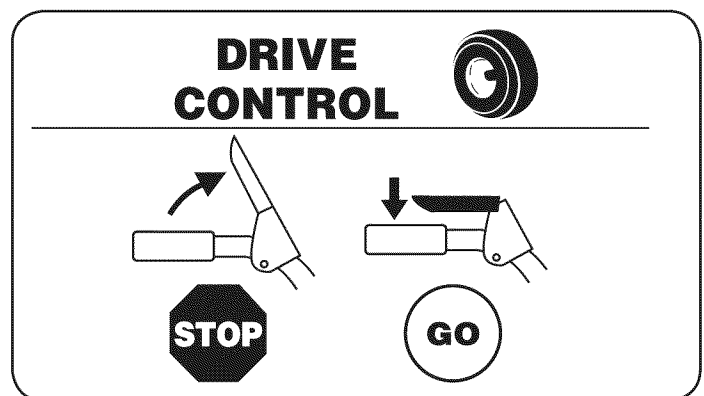

The drive control is located on the right handle. Squeeze the control grip against the handle to engage the wheel drive. Release the handle to stop.

The drive control also locks the auger control so that you can operate the chute directional control without interrupting the snow throwing process. If the auger control is engaged simultaneously with the drive control, the operator can release the auger control (on the left handle) and the auger will remain engaged. Release both controls to stop the auger and wheel drive.

**NOTE:** Always release the drive control before changing speeds. Failure to do so will result in increased wear on your machine's drive system.

# OPERATION

## Two-Way Chute-Pitch Control™

The two-way chute-pitch control is located on the left side of the handle panel and is used to control the distance of snow discharge from the chute.

- To change the upper chute angle to control the distance that snow is thrown, pivot the lever forward or backward.
- Move the lever forward to pivot the upper chute down and reduce the distance snow is thrown.
- Move the lever rearward to pivot the upper chute upward and increase the distance snow is thrown.

**NOTE:** To increase or decrease the tension on the two-way chute control, tighten or loosen the wing knob on the chute assembly.

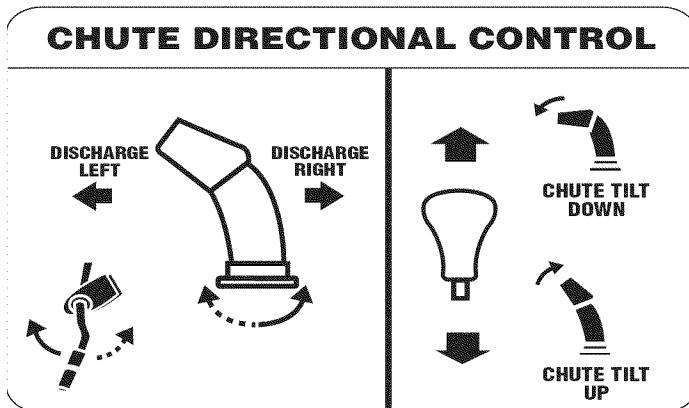

## Chute Directional Control

The chute directional control is located on the left side of the snow thrower.

- To change the direction in which snow is thrown, crank clockwise to discharge to the left and counterclockwise to discharge to the right.

## Wheel Steering Controls

The left and right wheel steering controls are located on the underside of the handles. Squeeze the right control to turn right; squeeze the left control to turn left.

**NOTE:** Operate the snow thrower in open areas until you are familiar with these controls.

## Headlight

The headlight is located inside of the handle panel.

## Drift cutters

The drift cutters are designed for use in deep snow. Their use is optional for normal snow conditions. Maneuver the snow thrower so that the cutters penetrate a high standing snow drift to assist snow falling into the augers for throwing.

## Chute Clean-Out Tool

The chute clean-out tool is conveniently fastened to the rear of the auger housing with a mounting clip. Should snow and ice become lodged in the chute assembly during operation, proceed as follows to safely clean the chute assembly and chute opening:

### **WARNING**

**Never use your hands to clear a clogged chute assembly. Shut off engine and remain behind handles until all moving parts have stopped before unclogging.**

1. Release both the Auger Control and the Drive Control.
2. Stop the engine by removing the ignition key.
3. Remove the clean-out tool from the clip which secures it to the rear of the auger housing.
4. Use the shovel-shaped end of the clean-out tool to dislodge and scoop any snow and ice which has formed in and near the chute assembly.
5. Refasten the clean-out tool to the mounting clip on the rear of the auger housing, reinsert the ignition key and start the snow thrower's engine.
6. While standing in the operator's position (behind the snow thrower), engage the auger control for a few seconds to clear any remaining snow and ice from the chute assembly.

## Before Starting Engine

### **WARNING**

**Read, understand, and follow all instructions and warnings on the machine and in this manual before operating.**

## Oil

The unit was shipped with oil in the engine. Check oil level before each operation to ensure adequate oil in the engine. For further instructions, refer to the Service & Maintenance section of this manual.

**NOTE:** Be sure to check the engine on a level surface with the engine stopped.

1. Remove the oil filler cap/dipstick and wipe the dipstick clean.
2. Insert the cap/dipstick into the oil filler neck, and tighten the cap turning clockwise until cap is seated.

**NOTE:** On some engines, a threaded screw cap will be present instead of the quarter turn locking cap. In the instance of a threaded oil cap/dipstick, DO NOT screw the cap/dipstick in to check. Check the oil by resting the cap/dipstick on the threads, but not screwing it in.

3. Remove the oil filler cap/dipstick. If the level is low, slowly add oil (5W-30, with a minimum classification of SF/SG) until oil level registers between high (H) and low (L).

**NOTE:** Do not overfill. Overfilling with oil may result in engine smoking, hard starting or spark plug fouling.

4. Replace and tighten cap/dipstick firmly before starting engine.

# OPERATION

## Gasoline

### WARNING

Use extreme care when handling gasoline. Gasoline is extremely flammable and the vapors are explosive. Never fuel the machine indoors or while the engine is hot or running. Extinguish cigarettes, cigars, pipes and other sources of ignition.

Use automotive gasoline (unleaded or low leaded to minimize combustion chamber deposits) with a minimum of 87 octane. Gasoline with up to 10% ethanol or 15% MTBE (Methyl Tertiary Butyl Ether) can be used. Never use an oil/gasoline mixture or dirty gasoline. Avoid getting dirt, dust, or water in the fuel tank. DO NOT use E85 gasoline.

- Refuel in a well-ventilated area with the engine stopped. Do not smoke or allow flames or sparks in the area where the engine is refueled or where gasoline is stored.
  - Do not overfill the fuel tank. After refueling, make sure the tank cap is closed properly and securely.
  - Be careful not to spill fuel when refueling. Spilled fuel or fuel vapor may ignite. If any fuel is spilled, make sure the area is dry before starting the engine.
  - Avoid repeated or prolonged contact with skin or breathing of vapor
1. Clean around fuel fill before removing cap to fuel to prevent debris from entering fuel tank..
  2. A fuel level indicator is located in the fuel tank. Fill tank until fuel reaches the fuel level indicator. See Figure 10 inset. Be careful not to overfill.

## Starting The Engine

### WARNING

Always keep hands and feet clear of moving parts. Do not use a pressurized starting fluid. Vapors are flammable.

**NOTE:** Allow the engine to warm up for a few minutes after starting. The engine will not develop full power until it reaches operating temperatures.

1. Make certain both the auger control and drive control are in the disengaged (released) position.
2. Insert key into slot. Make sure it snaps into place. Do not attempt to turn the key.

**NOTE:** The engine cannot start without the key is fully inserted into the ignition switch.

## Electric Starter

### WARNING



The optional electric starter is equipped with a grounded three-wire power plug, and is designed to operate on 120 volt AC household current. It must be used with a properly grounded three-prong extension cord and receptacle at all times to avoid the possibility of electric shock. Follow all instructions carefully prior to operating the electric starter. DO NOT use electric starter in the rain.

Determine that your home's wiring is a three-wire grounded system. Ask a licensed electrician if you are not certain.

### CAUTION

The extension cord can be any length, but *must* be rated for 15 amps at 125 volts, grounded and rated for outdoor use.

If you have a grounded three-prong receptacle, proceed as follows. If you do not have the proper house wiring, DO NOT use the electric starter under any conditions.

1. Plug the extension cord into the outlet located on the engine's surface. Plug the other end of extension cord into a three-prong 120-volt, grounded, AC outlet in a well-ventilated area.
2. Move throttle control to FAST (rabbit)  position.
3. Move choke to the CHOKE position  (cold engine start).
4. **NOTE:** If the engine is already warm, place choke control in the RUN position instead of CHOKE  position.
5. Push primer three times (3x), making sure to cover vent hole in primer bulb when pushing. If engine is warm, push primer only once. Always cover vent hole when pushing. Cool weather may require priming to be repeated.
6. Push starter button to start engine. Once the engine starts, immediately release starter button. Electric starter is equipped with thermal overload protection; system will temporarily shut-down to allow starter to cool if electric starter becomes overloaded.

### CAUTION



To prolong starter life, use short starting cycles (5 seconds maximum, then wait one minute).

7. As the engine warms, slowly rotate the choke control to the RUN position. If the engine falters, restart engine and run with choke at half-choke position for a short period of time, and then slowly rotate the choke into the RUN position.
8. After engine is running, disconnect power cord from electric starter. When disconnecting, always unplug the end at the wall outlet before unplugging the opposite end from the engine.

## Recoil Starter

### CAUTION

Do not pull the starter handle while the engine running.

1. Move throttle control to FAST (rabbit)  position.
2. Move choke to the CHOKE  position (cold engine start). If engine is warm, place choke in the RUN position.
3. Push primer three times, making sure to cover vent hole when pushing. If engine is warm, push primer only once. Always cover vent hole when pushing. Cool weather may require priming to be repeated.
4. Pull gently on the starter handle until it begins to resist, then pull quickly and forcefully to overcome the compression. Engine should start. Do not release the handle and allow it to snap back. Return rope SLOWLY to original position. If required, repeat this step.
5. As the engine warms, slowly rotate the choke control to the RUN position. If the engine falters, restart engine and run with choke at half-choke position for a short period of time, and then slowly rotate the choke into the RUN position.

# OPERATION

## ⚠ WARNING

To avoid unsupervised engine operation, never leave the machine unattended with the engine running. Turn the engine off after use and remove key.

## Stopping The Engine

After you have finished snow-throwing, run engine for a few minutes before stopping to help dry off any moisture on the engine.

1. Move throttle control to STOP  position.

## ⚠ CAUTION

Do NOT move the choke control to CHOKE  position to stop the engine. Backfire or engine damage may occur.

2. Remove the key. Removing the key will reduce the possibility of unauthorized starting of the engine while equipment is not in use. Keep the key in a safe place. The engine cannot start without the key.
3. Wipe all snow and moisture from the area around the engine as well as the area in and around the wheel drive control and auger control. Also, engage and release both controls several times.

## To Engage Drive

1. With the throttle control in the Fast (rabbit ) position, move speed selector lever into one of the six forward (F) positions or two reverse (R) positions. Select a speed appropriate for the snow conditions and a pace you're comfortable with.

**NOTE:** When selecting a Drive Speed, use the slower speeds until you are comfortable and familiar with the operation of the snow thrower.

2. Squeeze the drive control against the handle and the snow thrower will move. Release it and drive motion will stop.

**NOTE:** NEVER reposition the speed selector lever (change speeds or direction of travel) without first releasing the drive control and bringing the snow thrower to a complete stop. Doing so will result in premature wear to the snow thrower's drive system.

## To Engage Auger

1. To engage the auger and start throwing snow, squeeze the auger control against the left handle. Release to stop the auger.

## Replacing Shear pins

The augers are secured to the spiral shaft with shear pins and bow-tie cotter pins. If the auger should strike a foreign object or ice jam, the snow thrower is designed so that the pins may shear. If the augers will not turn, check to see if the pins have sheared. See Figure 17.

**NOTE:** Two extra shear pins are supplied in the manual bag.

## ⚠ CAUTION

NEVER replace the auger shear pins with anything other than Sears SKU# 88389/OEM Part No. 738-04155 replacement shear pins. Any damage to the auger gearbox or other components as a result of failing to do so will NOT be covered by your snow thrower's warranty.

## ⚠ WARNING

Always turn off the snow thrower's engine and remove the key prior to replacing shear pins.

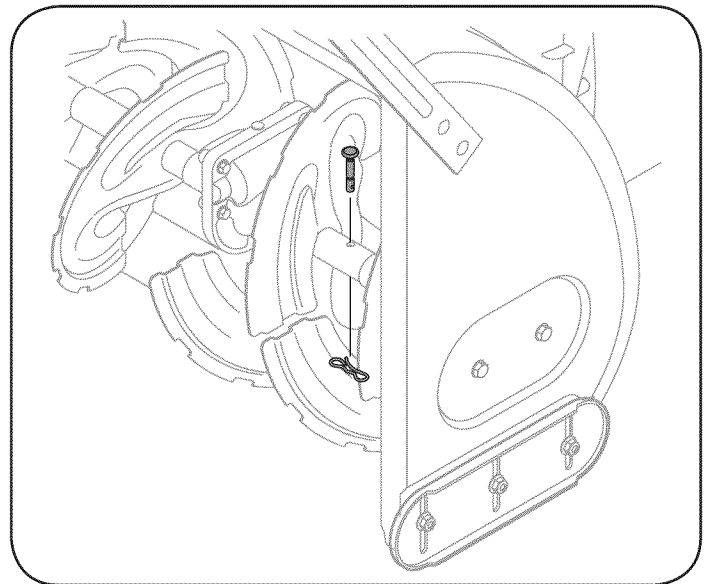

Figure 17

# SERVICE AND MAINTENANCE

## MAINTENANCE SCHEDULE

### ⚠ WARNING

Before performing any type of maintenance/service, disengage all controls and stop the engine. Wait until all moving parts have come to a complete stop. Remove the key to prevent unintended starting. Always wear safety glasses during operation or while performing any adjustments or repairs.

Follow the maintenance schedule given below. This chart describes service guidelines only. Use the Service Log column to keep track of completed maintenance tasks. To locate the nearest Sears Service Center or to schedule service, simply contact Sears at 1-800-4-MY-HOME®.

Interval	Item	Service	Service Log
Each Use	1. Engine oil level 2. Loose or missing hardware 3. Unit and engine.	1. Check 2. Tighten or replace 3. Clean	
1st 5 - 8 hours	1. Engine oil	1. Change	
25 hours	1. Engine oil† 2. Control linkages and pivots	1. Change 2. Lube with light oil	
50 hours	1. Engine oil	1. Change	
Annually or 100 hours	1. Spark plug	1. Clean and re-gap, or else replace with new plug.	
Before Storage	1. Fuel system	1. Run engine until it stops from lack of fuel or add a gasoline additive to the gas in the tank.	

† Under heavy load or in high temperatures

## Engine Maintenance

### Checking Engine Oil

### ⚠ WARNING

Before lubricating, repairing, or inspecting, disengage all controls and stop engine. Wait until all moving parts have come to a complete stop. Remove the key to prevent unintended firing of the engine.

**NOTE:** Check the oil level before each use to be sure correct oil level is maintained.

When adding oil to the engine, refer to viscosity chart below. Engine oil capacity is approximately 37 ounces. Do not over-fill. Use a 4-stroke, or an equivalent high detergent, premium quality motor oil certified to meet or exceed U.S. automobile manufacturer's requirements for service classification SG, SF. Motor oils classified SG, SF will show this designation on the container.

1. Remove the oil filler cap/dipstick and wipe the dipstick clean.
2. Insert the cap/dipstick into the oil filler neck, but do *not* screw it in.  
**NOTE:** On some engines, a threaded screw cap will be present instead of the quarter turn locking cap. In the instance of a threaded oil cap/dipstick, DO NOT screw the cap/dipstick in to check. Check the oil by resting the cap/dipstick on the threads, but not screwing it in.
3. Remove the oil filler cap/dipstick. If level is low, slowly add oil until oil level registers between high (H) and low (L). See Figure 18.
4. Replace and tighten cap/dipstick firmly before starting engine.

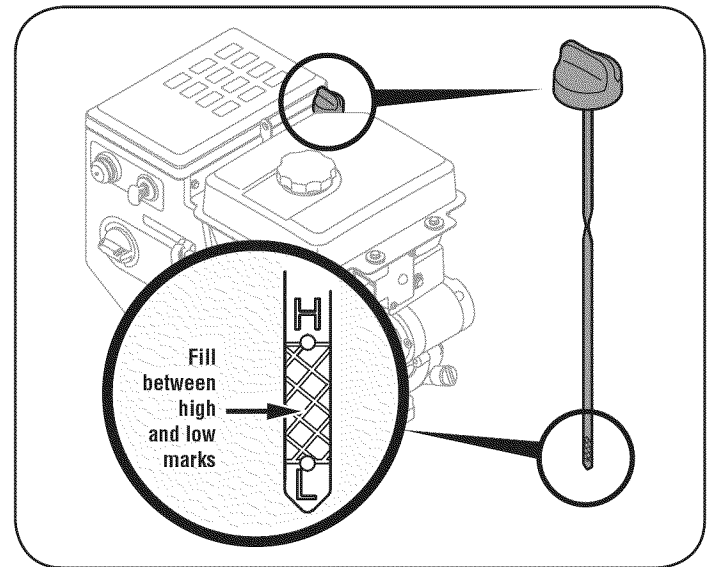

Figure 18

### Changing Engine Oil

**NOTE:** Change the engine oil after the first 5 hours of operation and once a season or every 50 hours thereafter.

1. Drain fuel from tank by running engine until the fuel tank is empty. Be sure fuel fill cap is secure.
2. Place suitable oil collection container under oil drain plug.
3. Remove oil drain plug. See Figure 19.
4. Tip engine to drain oil into the container. Used oil must be disposed of at a proper collection center.

# SERVICE AND MAINTENANCE

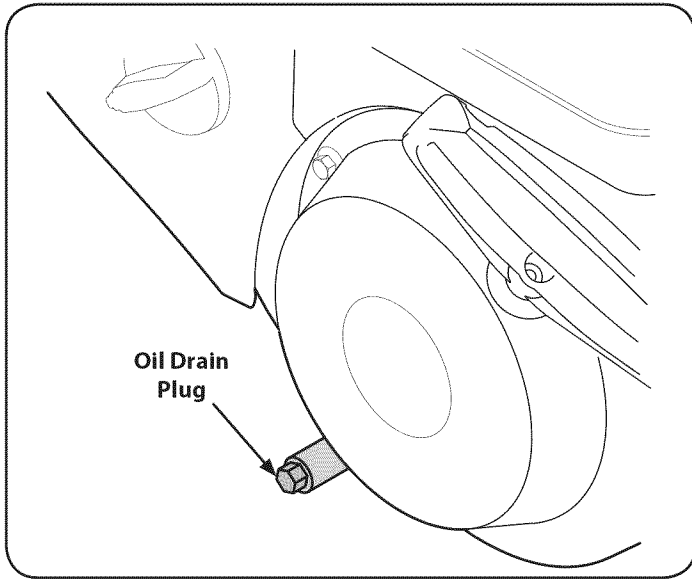

Figure 19

## CAUTION

Used oil is a hazardous waste product. Dispose of used oil properly. Do not discard with household waste. Check with your local authorities or Sears Service Center for safe disposal/recycling facilities.

- Reinstall the drain plug and tighten it securely.
- Refill with the recommended oil and check the oil level. See Recommended Oil Usage chart. The engine's oil capacity is 37 ounces.

## CAUTION

DO NOT use non-detergent oil or 2-stroke engine oil. It could shorten the engine's service life.

	Synthetic 0W-30				
	5W-30				
(°F)	-40°	-20°	0°	20°	40°
(°C)	-30°	-20°	-10°	0°	

- Reinstall the oil filler cap/dipstick securely.

## CAUTION

Thoroughly wash your hands with soap and water as soon as possible after handling used oil.

### Checking Spark Plug

## WARNING

DO NOT check for spark with spark plug removed. DO NOT crank engine with spark plug removed.

## WARNING

If the engine has been running, the muffler will be very hot. Be careful not to touch the muffler.

**NOTE:** Check the spark plug once a season or every 25 hours of operation. Change the spark plug once a season or every 100 hours.

To ensure proper engine operation, the spark plug must be properly gapped and free of deposits.

- Remove the spark plug boot and use a spark plug wrench to remove the plug. See Figure 20.

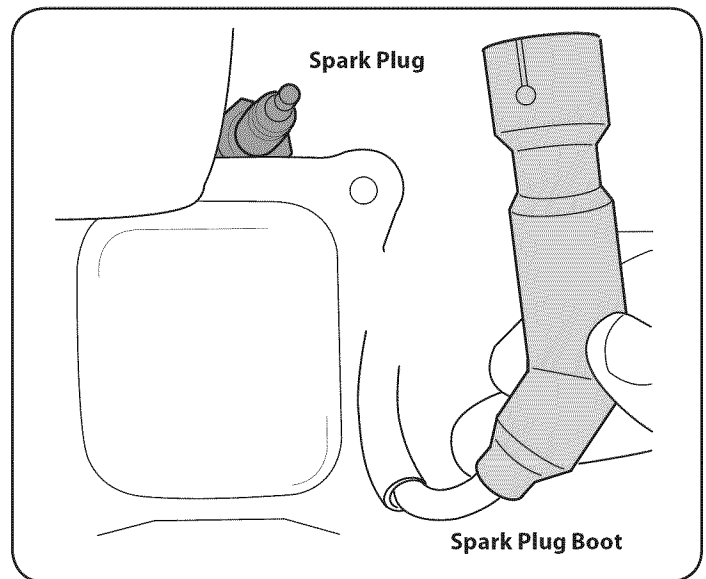
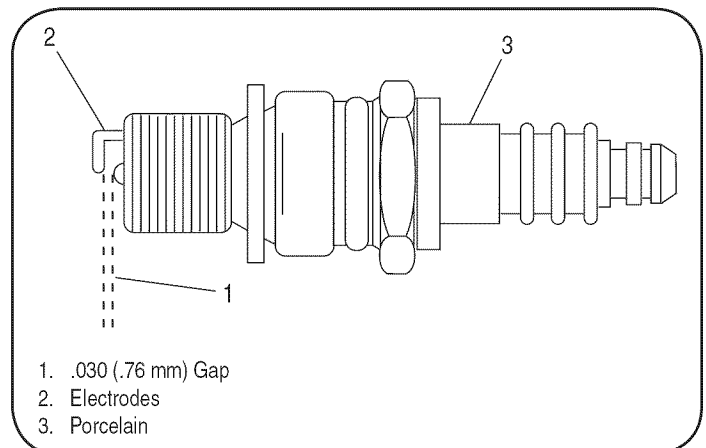

Figure 20

- Visually inspect the spark plug. Discard the spark plug if there is apparent wear, or if the insulator is cracked or chipped. Clean the spark plug with a wire brush if it is to be reused.
- Measure the plug gap with a feeler gauge. Correct as necessary by bending side electrode. See Figure 21. The gap should be set to .02-.03 inches (0.60-0.80 mm).



- .030 (.76 mm) Gap
- Electrodes
- Porcelain

Figure 21

# SERVICE AND MAINTENANCE

4. Check that the spark plug washer is in good condition and thread the spark plug in by hand to prevent cross-threading.
5. After the spark plug is seated, tighten with a spark plug wrench to compress the washer.

**NOTE:** When installing a new spark plug, tighten 1/2-turn after the spark plug seats to compress the washer. When reinstalling a used spark plug, tighten 1/8- to 1/4-turn after the spark plug seats to compress the washer.

## ⚠ CAUTION

The spark plug must be tightened securely. A loose spark plug can become very hot and can damage the engine.

## Carburetor Adjustment

The carburetor is not user adjustable. Contact Sears Parts & Repair for adjustment.

## Lubrication

### Drive and Shifting Mechanism

At least once a season or after every 25 hours of operation, remove rear cover. Lubricate all chains, sprockets, gears, bearings, shafts, and the shifting mechanism. Use engine oil or a spray lubricant. Refer to Figure 22.

**NOTE:** Before tipping the unit on the front housing, run the fuel tank empty so fuel does not leak out of the fuel cap.

1. Carefully pivot the snow thrower up and forward so that it rests on the auger housing.
2. Remove the frame cover from the underside of the snow thrower by removing the self-tapping screws which secure it. Refer to Figure 27.
3. Apply a light coating of engine oil (or 3-in-1 oil) to the hex shaft. See Figure 22.

**NOTE:** Be careful not to get any oil on the aluminum drive plate or rubber friction wheel. Doing so will hinder the snow thrower's drive system. Wipe off any excess or spilled oil.

4. At least once a season grease the wheel axle with Arctic grease, part number 737-0318. The grease fitting is located on the wheel axle tube behind the wheel axle support bracket.

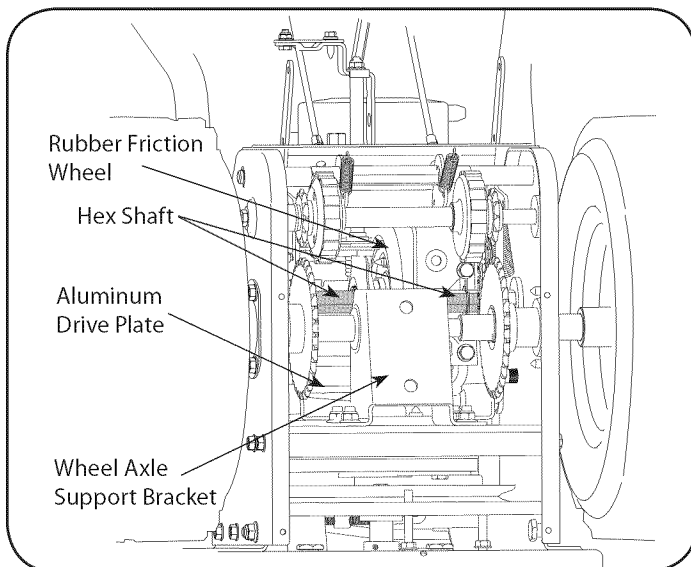

Figure 22

## Wheels

At least once a season, remove both wheels. Clean and coat the axles with a multipurpose automotive grease before reinstalling wheels.

## Chute Directional Control

Once a season, lubricate the eye bolt bushing and the spiral with 3-in-1 oil.

## Auger Shaft

At least once a season, one at a time, remove all of the shear pins from the auger shaft. Spray lubricant inside the hub of each auger spiral assembly and around the spacers on the auger shaft.

Grease fittings can also be found at each end of the auger shaft. Lubricate with a grease gun once a season. See Figure 23.

## Gear Case

The auger gear case is equipped with a grease fitting. Lubricate with grease once a season (order part number 737-0168). See Figure 23.

**NOTE:** To relieve pressure, remove the vent plug before lubricating the gear case. See Figure 23. Failure to do so could result in damage to the gear case seals.

## Augers

Each of the auger spiral assemblies is secured to the spiral shaft with a shear pin and cotter pin. If the auger should strike a foreign object or ice jam, the snow thrower is designed so that the pins may shear.

1. If augers do not turn, check to see if pins have sheared.
2. Replace the pins if needed. Two replacement shear pins and cotter pins have been provided with the snow thrower. Spray an oil lubricant into shaft before inserting new pins and securing with new cotter pins. See Figure 23.

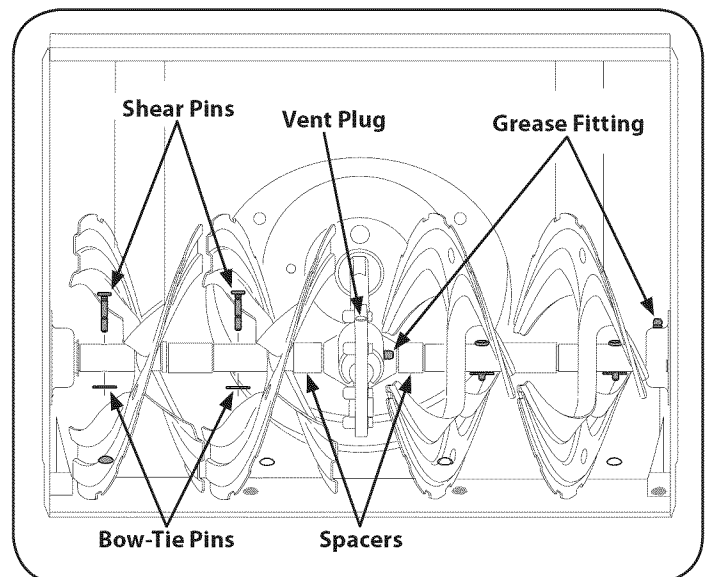

Figure 23

# SERVICE AND MAINTENANCE

## Shave Plate and Skid Shoes

The shave plate and skid shoes on the bottom of the snow thrower are subject to wear. They should be checked periodically and replaced when necessary.

### Skid Shoes

**NOTE:** The skid shoes on this machine have two wear edges. When one side wears out, they can be rotated 180° to use the other edge.

1. Remove the six carriage bolts and hex nuts that secure the two skid shoes to the sides of the auger housing. Refer to Figure 24.
2. Position the new skid shoes and secure with the carriage bolts and hex nuts. Make certain the skid shoes are adjusted to be level.

### Shave Plate

1. Remove the hex nuts and carriage bolts that secure the shave plate to the bottom of the housing. Refer to Figure 24.
2. Remove the rear most hex nut and carriage bolt securing the back of each skid shoe to the sides of the housing. Loosen the four remaining hex nuts securing the skid shoes.
3. Slide the shave plate out of the off-set slot at the bottom of the housing, and from between the skid shoes and side panels of the housing.
4. With the mounting holes toward the back of the unit, slide the new shave plate into position and secure with the fasteners removed previously.

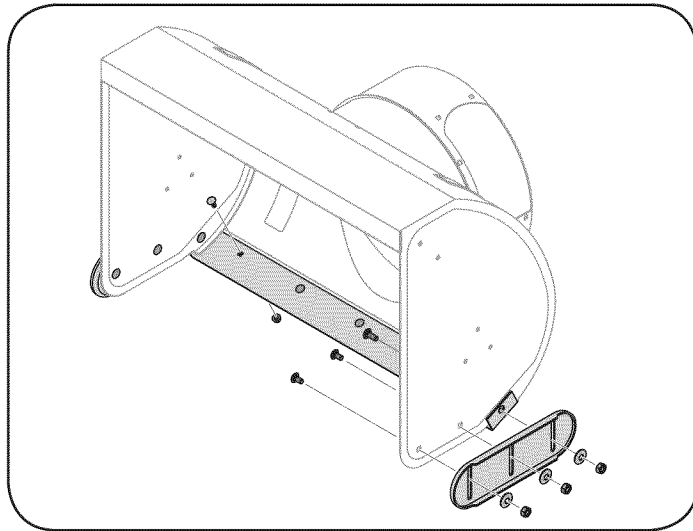

Figure 24

## Adjustments

### Shift Cable

If the full range of speeds (forward and reverse) cannot be achieved, refer to the Figure 25 and adjust the shift cable as follows:

1. Place the shift lever in the fastest forward speed position.
2. Loosen the hex nut on the shift cable index bracket. See Figure 25.
3. Pivot the bracket downward to take up slack in the cable.
4. Retighten the hex nut.

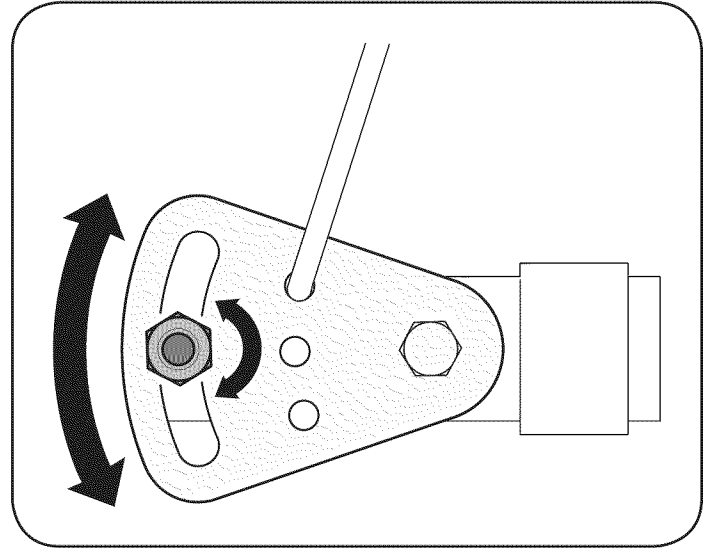

Figure 25

### Chute Bracket Adjustment

If the spiral at the bottom of the chute directional control is not fully engaging with the chute assembly, the chute bracket can be adjusted. To do so:

1. Loosen the two nuts which secure the chute bracket and reposition it slightly. See Figure 26.
2. Retighten the nuts.

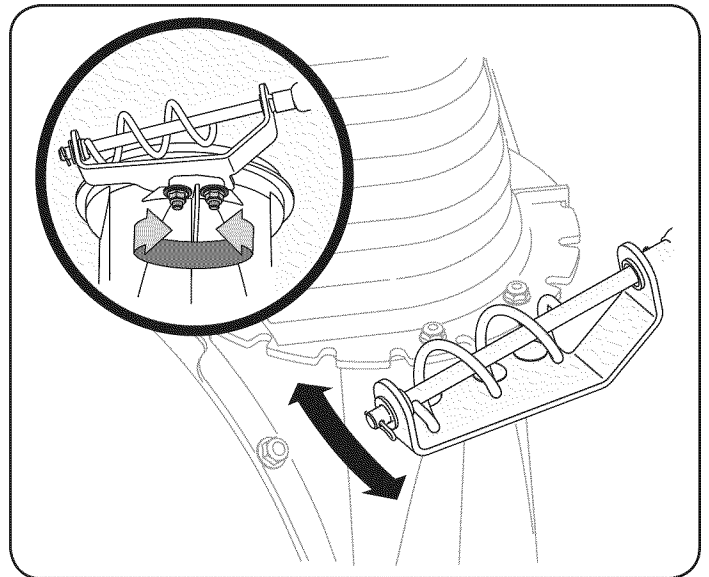

Figure 26

### Chute Control

The distance snow is thrown can be adjusted by adjusting the angle of the chute assembly. Refer to the Operation section for instructions.

The remote chute control cables have been pre-adjusted at the factory. Move the remote chute lever on the control panel forward to pivot the upper chute down; move the lever rearward to pivot the upper chute up.



# SERVICE AND MAINTENANCE

## Wheel drive control

Refer to the Adjustment section of the Assembly instructions to adjust the wheel drive control. To further check the adjustment, proceed as follows:

1. With the snow thrower tipped forward (be certain to run the fuel tank dry before tipping the unit forward), remove the frame cover underneath the snow thrower by removing the self-tapping screws. See Figure 27.

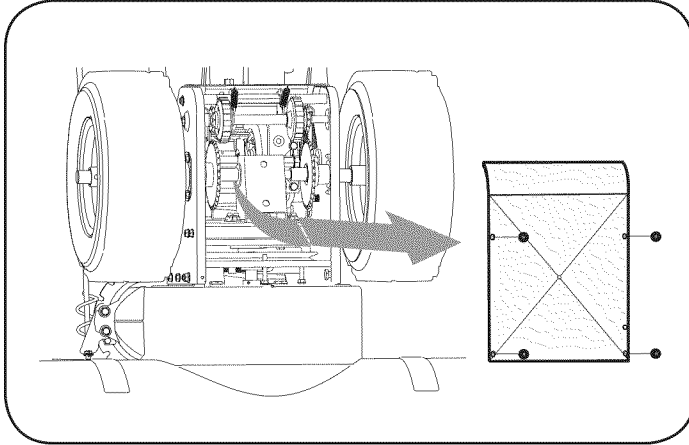

Figure 27

2. Locate the opening between the axle support bracket and the front frame support (See Figure 28). Looking through this opening, with the wheel drive control released, there must be clearance between the friction wheel and the drive plate in all positions of the speed selector lever.
3. With the wheel drive control engaged, the friction wheel must contact the drive plate. See Figure 28.

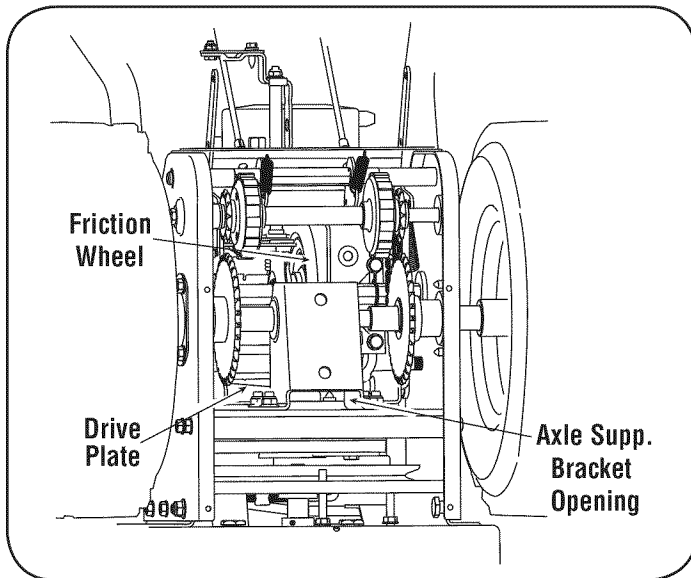

Figure 28

4. If there is no friction wheel clearance, or the friction wheel does not solidly contact the drive plate, re-adjust the lock nut on the lower end of the drive cable following the instructions in the Assembly section.
5. Reassemble the frame cover.

## Auger Control

Refer to the Assembly section for instructions on adjusting the auger control cable.

## Skid Shoes

Refer to the Assembly section for instructions on adjusting the skid shoes.

## Tire Pressure

Refer to the Assembly section for instructions on adjusting the tire pressure.

## Belt replacement

### Belt Removal Preparation

1. Remove the chute crank rod from the chute crank assembly by removing the hair pin clip shown in Figure 29. Move the chute crank rod away from the assembly as shown.
2. Remove three self-tap screws on both sides of the transmission housing as shown in Figure 29.

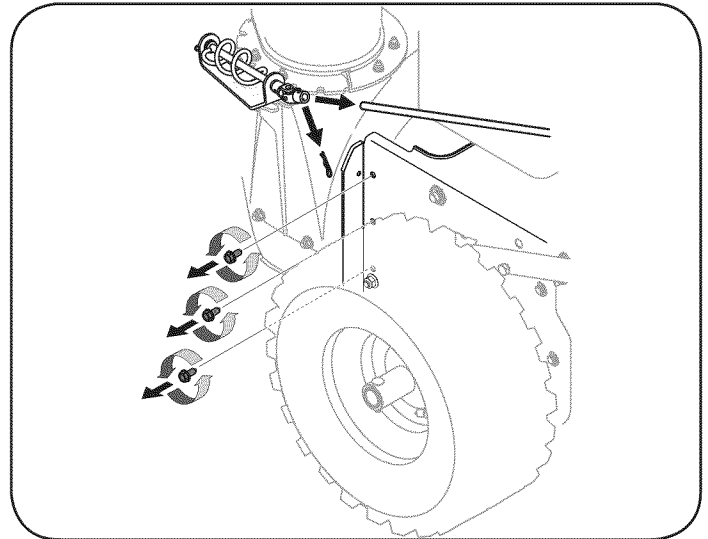

Figure 29

3. Remove the plastic belt cover, located near the engine, by removing the three self-tapping screws that secure it. See Figure 30.

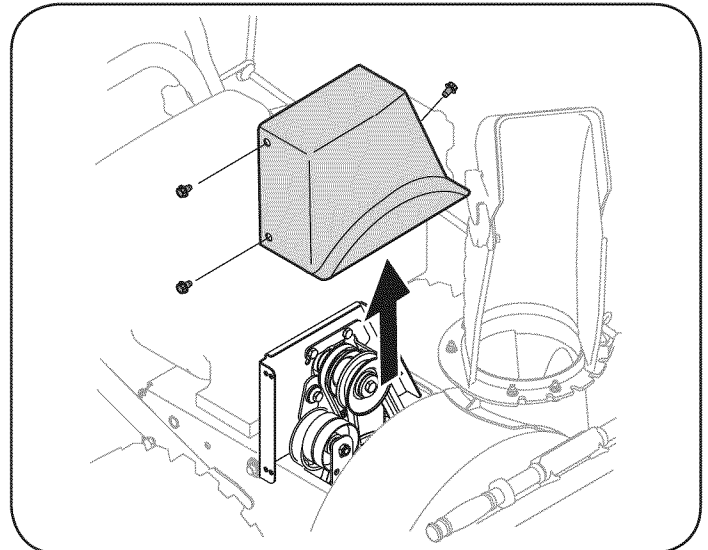

Figure 30

## SERVICE AND MAINTENANCE

- Loosen the bolt shown in Figure 31 securing the belt keeper bracket and remove the other bolt. Push the belt keeper and bracket up off the engine pulley.

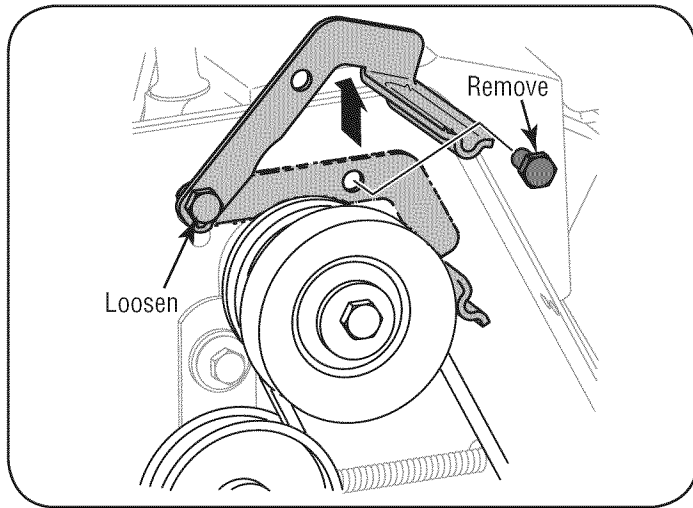

Figure 31

### Auger Belt Replacement

- Remove the bow-tie clip and flat washer from the ferrule in order to disconnect the auger idler rod from the brake bracket assembly. See Figure 32.

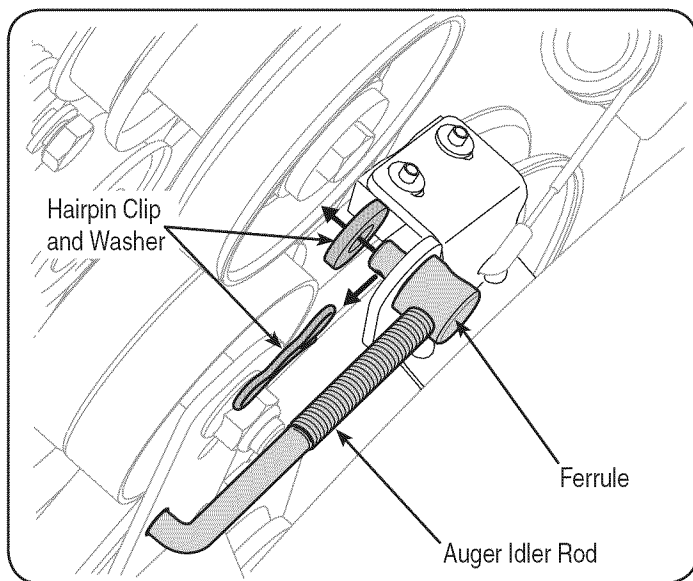

Figure 32

**NOTE:** Make sure that the location of the ferrule on the auger idler rod is maintained.

- Slip the auger control belt (the front belt) off the engine pulley.
- Pull the brake bracket assembly towards the cable guide roller and unhook the auger cable z-fitting. See Figure 33.
- From both sides of the the frame assembly, use a 1/2" wrench to remove the three hex tap screws securing the frame to the auger housing assembly. Refer back to Figure 29.

**NOTE:** Do not remove the lower hex flange lock nut on each side.

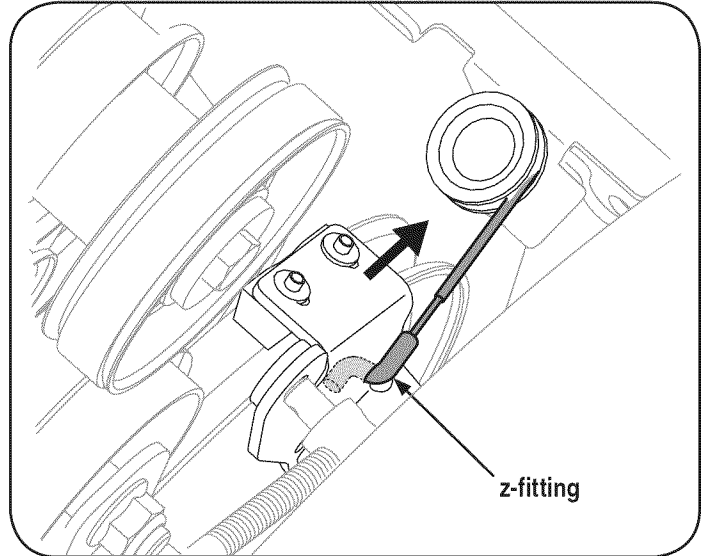

Figure 33

- Place a block of wood underneath the auger housing as shown in Figure 34 and separate auger housing from the frame by tilting the housing forward and pulling up the handles.
- Block the impeller with a piece of wood to prevent it from spinning and use a 1/2" wrench to remove the hex screw and flat washer from the center of the pulley on the auger housing. See A in Figure 35.
- Lift the brake bracket assembly out of the pulley groove (B in Figure 35) and slide the pulley assembly off the posts of the auger pulley adapter (C) to remove the old belt.

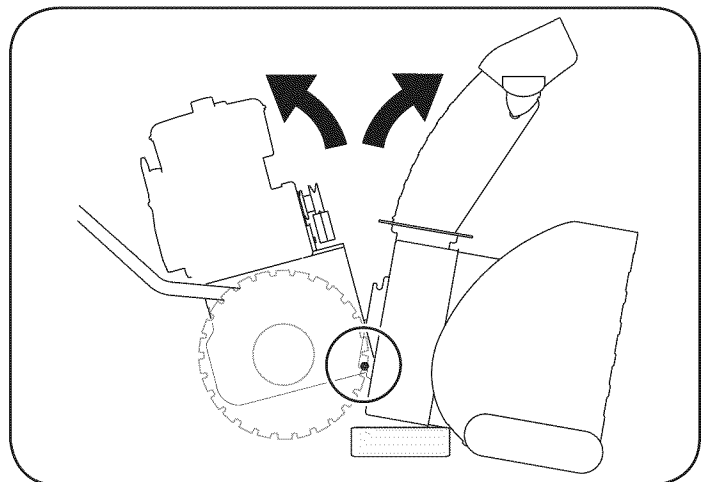

Figure 34

**NOTE:** The pulley adapter may slide off the auger input shaft when removing the pulley. Use extra caution to ensure the adapter does not fall and/or get damaged when removing the pulley.

- Place the new auger belt in the V-groove of the auger pulley and place the pulley w/belt inside the belt keepers.
- Turn the pulley as necessary to align its three slots approximately with the posts of the pulley adapter, then pivot the brake bracket assembly away from the pulley groove. While aligning the pulley slots and adapter posts, push the auger pulley fully onto the adapter. Refer to Figure 35. Ensure the brake puck of the brake bracket assembly aligns and is fully seated in the pulley groove.

## SERVICE AND MAINTENANCE

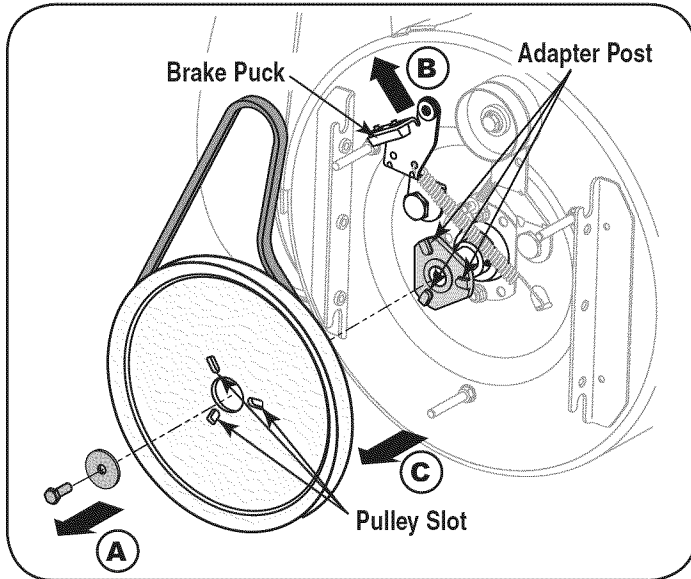

Figure 35

**NOTE:** If the pulley adapter was removed with the pulley, align the splines of the pulley adapter and auger input shaft, and push the pulley and adapter onto the input shaft. Refer to Figure 36.

9. Slide the washer onto the hex screw removed earlier and apply Loctite 262 to the threads of the hex screw.
10. Insert the hex screw through the pulley assembly and into the threads of the input shaft. Torque the hex screw to 250-325 in. lbs. to secure the auger pulley assembly on the input shaft.
11. If also replacing the drive belt, proceed to the "Drive Belt" instructions. If not, reposition the transmission frame back onto the auger housing.
12. Install the drive belt on the engine pulley, re-connect the auger cable z-fitting and auger idler rod ferrule to the brake bracket. Reposition and secure the engine pulley belt guard, and re-install the belt cover.

**NOTE:** Make sure to remove the piece of wood blocking the impeller. Check the auger drive belt adjustment. With the auger clutch lever in the disengaged position, the top surface of the new belt should be even with the outside diameter of the pulley.

To adjust, disconnect ferrule from brake bracket assembly. Thread ferrule in (towards idler) to increase tension on belt, or out to decrease belt tension.

**NOTE:** The brake puck must always be firmly seated in the pulley groove when auger control is disengaged.

**IMPORTANT:** Repeat the "Auger Drive Control Test" from the Assembly section before operating snow thrower.

### Drive Belt Replacement

If not already done, remove the auger drive belt from the front pulley of the engine double pulley. Refer to "Auger Belt Replacement" instructions in the previous sub-section.

1.
  - a. Pull the idler pulley away from the backside of the drive belt to relieve the tension. See Figure 36.
  - b. Slip the drive belt off the idler pulley. Carefully release the idler pulley.

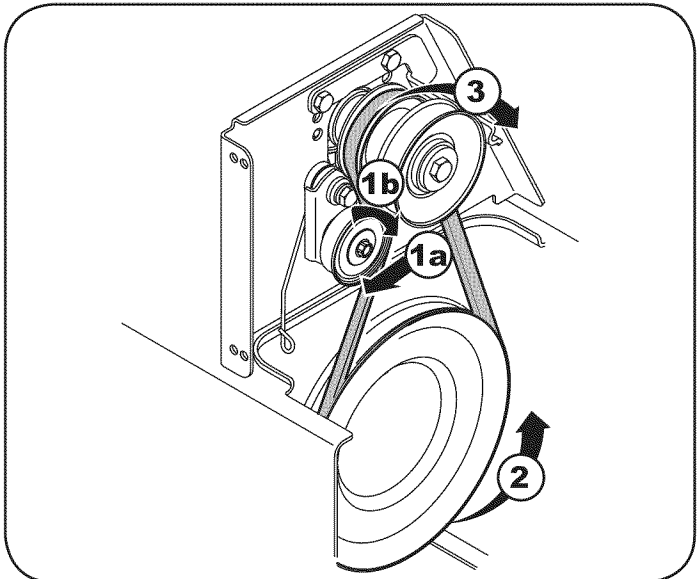

Figure 36

2. Roll the drive belt off the lower drive pulley.
3. Remove the belt from the engine pulley.
4. Install the new belt on the pulleys in the reverse order and re-tension with the idler pulley.
5. Reassemble by performing the previous steps in the opposite order and manner of removal.

### CHANGING FRICTION WHEEL

The rubber on the friction wheel is subject to wear and should be checked periodically. Replace the friction wheel if any signs of wear or cracking are found.

1. Run the unit's fuel tank dry before performing Step 2. Do not attempt to pour fuel from the engine.
2. Tip the snow thrower up and forward, so that it rests on the housing.
3. Remove screws from the frame cover underneath the snow thrower (refer to Figure 37). Remove the right wheel from the axle.

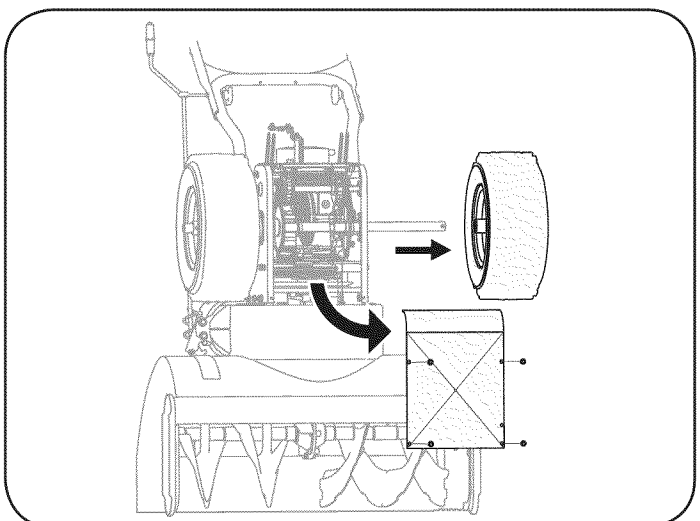

Figure 37

## SERVICE AND MAINTENANCE

- Using a 3/4" wrench, hold the hex shaft and remove the hex screw and belleville washer and bearing from left side of the frame. Refer to Figure 38.

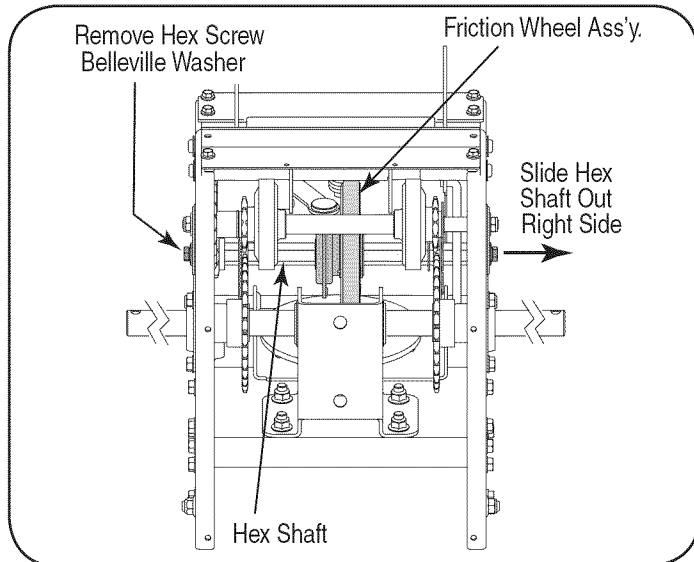

Figure 38

- Holding the friction wheel assembly, slide the hex shaft out of the friction wheel assembly and the right side of the frame. The spacer on the left side of the hex shaft will fall and the sprocket should remain hanging loose in the chain.
- Lift the friction wheel assembly out between the axle shaft and the drive shaft assemblies.
- Remove four screws securing the friction wheel to the hub assembly (refer to Figure 39). Discard old friction wheel.

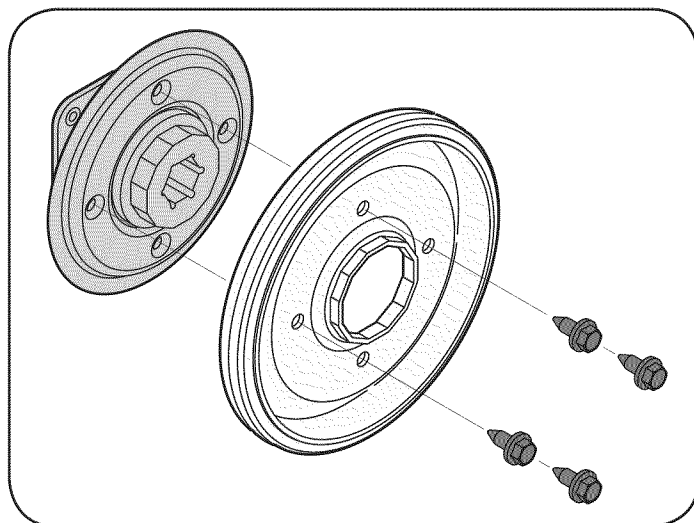

Figure 39

- Reassemble the new friction wheel onto the hub assembly, tightening the four screws in rotation and with equal force. It is important to assemble the friction wheel symmetrically for proper functioning.
- Reposition the friction wheel assembly in the snow thrower frame. Insert the pin from the speed selector arm assembly into the friction wheel assembly and hold assembly in position. Refer to Figure 40.

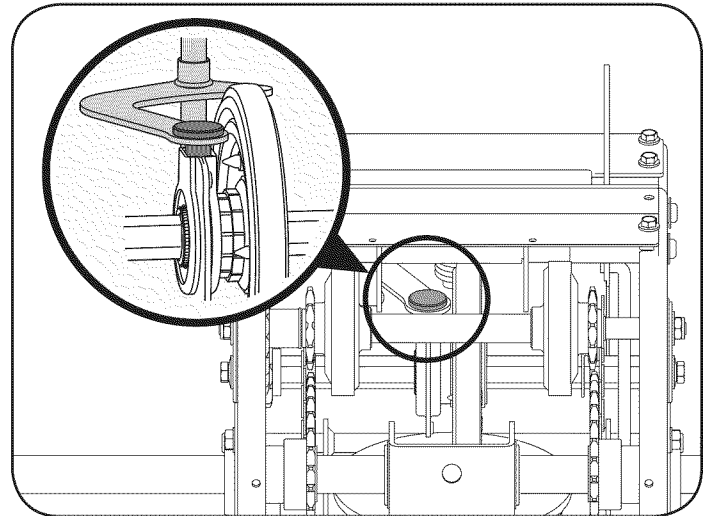

Figure 40

- Slide the hex shaft through the right side of the frame toward the left side and through the friction wheel assembly.
- After making certain that the chain is on both the large and the small sprocket, align the hex shaft with the hex hub of the small sprocket, and slide the shaft through the sprocket.

**NOTE:** If the sprocket fell from the snow thrower while removing the hex shaft, place the sprocket on the chain. Realign the sprocket on the chain with the hex hub facing the right side of unit. Position the hex hub of the sprocket toward the friction wheel when sliding the sprocket on to the hex shaft.

- Slide the spacer onto the end of the hex shaft.

**Note:** The spacer is to be placed on the hex shaft between the sprocket and bearing previously removed on the left side of the frame.

- Align the bearing on the right end of the hex shaft with the hole in the right side of the frame, then push the hex shaft to the left into position in the frame.
- Slide the bearing onto the left end of the hex shaft and press into the hole on the left side the frame.
- Place the belleville washer (rounded side toward head) onto the hex screw removed earlier, and insert the screw into the threaded hole of the hex shaft.
- Gradually tighten the hex screw to fully seat the bearings in each side of the frame and to secure the hex shaft.
- Position the frame cover on the bottom of the frame and secure with the self-tapping screws. Pivot the snow thrower down to it normal operating position.

**IMPORTANT:** Repeat the drive control test from the Assembly section of this manual before operating the snow thrower.

# OFF-SEASON STORAGE

If the snow thrower will not be used for 30 days or longer, or if it is the end of the snow season when the last possibility of snow is gone, the equipment needs to be stored properly. Follow storage instructions below to ensure top performance from the snow thrower for many more years.

## Preparing Engine

Engines stored over 30 days need to be drained of fuel to prevent deterioration and gum from forming in fuel system or on essential carburetor parts. If the gasoline in your engine deteriorates during storage, you may need to have the carburetor, and other fuel system components, serviced or replaced.

1. Remove all fuel from tank by running engine until it stops. Do not attempt to pour fuel from the engine.
  2. Change the engine oil.
  3. Remove spark plug and pour approximately 1 oz. (30 ml) of clean engine oil into the cylinder. Pull the recoil starter several times to distribute the oil, and reinstall the spark plug.
  4. Clean debris from around engine, and under, around, and behind muffler. Apply a light film of oil on any areas that are susceptible to rust.
- Store in a clean, dry and well ventilated area away from any appliance that operates with a flame or pilot light, such as a furnace, water heater, or clothes dryer. Avoid any area with a spark producing electric motor, or where power tools are operated.
  - If possible, avoid storage areas with high humidity.
  - Keep the engine level in storage. Tilting can cause fuel or oil leakage.

## Preparing Snow Thrower

- When storing the snow thrower in an unventilated or metal storage shed, care should be taken to rustproof the equipment. Using a light oil or silicone, coat the equipment, especially any chains, springs, bearings and cables.
- Remove all dirt from exterior of engine and equipment.
- Follow lubrication recommendations.
- Store equipment in a clean, dry area.
- Inflate the tires to the maximum PSI. Refer to tire sidewall.

### **WARNING**

Never store snow thrower with fuel in tank indoors or in poorly ventilated areas, where fuel fumes may reach an open flame, spark or pilot light as on a furnace, water heater, clothes dryer or gas appliance.

# TROUBLESHOOTING

Problem	Cause	Remedy
Engine fails to start	<ol style="list-style-type: none"> <li>1. Choke control not in CHOKE position.</li> <li>2. Spark plug wire disconnected.</li> <li>3. Faulty spark plug.</li> <li>4. Fuel tank empty or stale fuel.</li> <li>5. Engine not primed.</li> <li>6. Key not inserted.</li> <li>7. Extension cord not connected (when using electric start button, on models so equipped).</li> </ol>	<ol style="list-style-type: none"> <li>1. Move choke control to CHOKE position.</li> <li>2. Connect wire to spark plug.</li> <li>3. Clean, adjust gap, or replace.</li> <li>4. Fill tank with clean, fresh gasoline.</li> <li>5. Prime engine as instructed in the Operation Section.</li> <li>6. Insert key fully into the switch.</li> <li>7. Connect one end of the extension cord to the electric starter outlet and the other end to a three-prong 120-volt, grounded, AC outlet.</li> </ol>
Engine running erratically/ inconsistent RPM (hunting or surging)	<ol style="list-style-type: none"> <li>1. Engine running on CHOKE.</li> <li>2. Stale fuel.</li> <li>3. Water or dirt in fuel system.</li> <li>4. Over-governed engine.</li> </ol>	<ol style="list-style-type: none"> <li>1. Move choke control to RUN position.</li> <li>2. Fill tank with clean, fresh gasoline.</li> <li>3. Drain fuel tank by running engine until it stops. Refill with fresh fuel.</li> <li>4. Contact your Sears Parts &amp; Repair Center.</li> </ol>
Excessive vibration	<ol style="list-style-type: none"> <li>1. Loose parts or damaged auger.</li> </ol>	<ol style="list-style-type: none"> <li>1. Stop engine immediately and disconnect spark plug wire. Tighten all bolts and nuts. If vibration continues, have unit serviced by a Sears Parts &amp; Repair Center.</li> </ol>
Loss of power	<ol style="list-style-type: none"> <li>1. Spark plug wire loose.</li> <li>2. Gas cap vent hole plugged.</li> </ol>	<ol style="list-style-type: none"> <li>1. Connect and tighten spark plug wire.</li> <li>2. Remove ice and snow from gas cap. Be certain vent hole is clear.</li> </ol>
Unit fails to propel itself	<ol style="list-style-type: none"> <li>1. Drive cable in need of adjustment.</li> <li>2. Drive belt loose or damaged.</li> <li>3. Worn friction wheel.</li> </ol>	<ol style="list-style-type: none"> <li>1. Adjust drive control cable. Refer to Service and Maintenance section.</li> <li>2. Replace drive belt. Refer to Service and Maintenance section.</li> <li>3. Have friction wheel replaced at a Sears Parts &amp; Repair Center.</li> </ol>
Unit fails to discharge snow	<ol style="list-style-type: none"> <li>1. Chute assembly clogged.</li> <li>2. Foreign object lodged in auger.</li> <li>3. Auger cable in need of adjustment.</li> <li>4. Auger belt loose or damaged.</li> <li>5. Shear pin(s) sheared.</li> </ol>	<ol style="list-style-type: none"> <li>1. Stop engine immediately and disconnect spark plug wire. Clean chute assembly and inside of auger housing with clean-out tool or a stick.</li> <li>2. Stop engine immediately and disconnect spark plug wire. Remove object from auger with clean-out tool or a stick.</li> <li>3. Adjust auger control cable. Refer to Assembly section.</li> <li>4. Replace auger belt. Refer to Service and Maintenance section.</li> <li>5. Replace with new shear pin(s).</li> </ol>
Chute fails to easily rotate 180 degrees	<ol style="list-style-type: none"> <li>1. Chute assembled incorrectly.</li> </ol>	<ol style="list-style-type: none"> <li>1. Disassemble chute control and reassemble as directed in the Assembly section.</li> </ol>

## NEED MORE HELP?

You'll find the answer and more on [managemylife.com](http://managemylife.com) – for free!

- Find this and all your other product manuals online.
- Get answers from our team of home experts.
- Get a personalized maintenance plan for your home.
- Find information and tools to help with home projects.



brought to you by Sears

# PARTS LIST

Craftsman Snow Thrower Model 247.883971

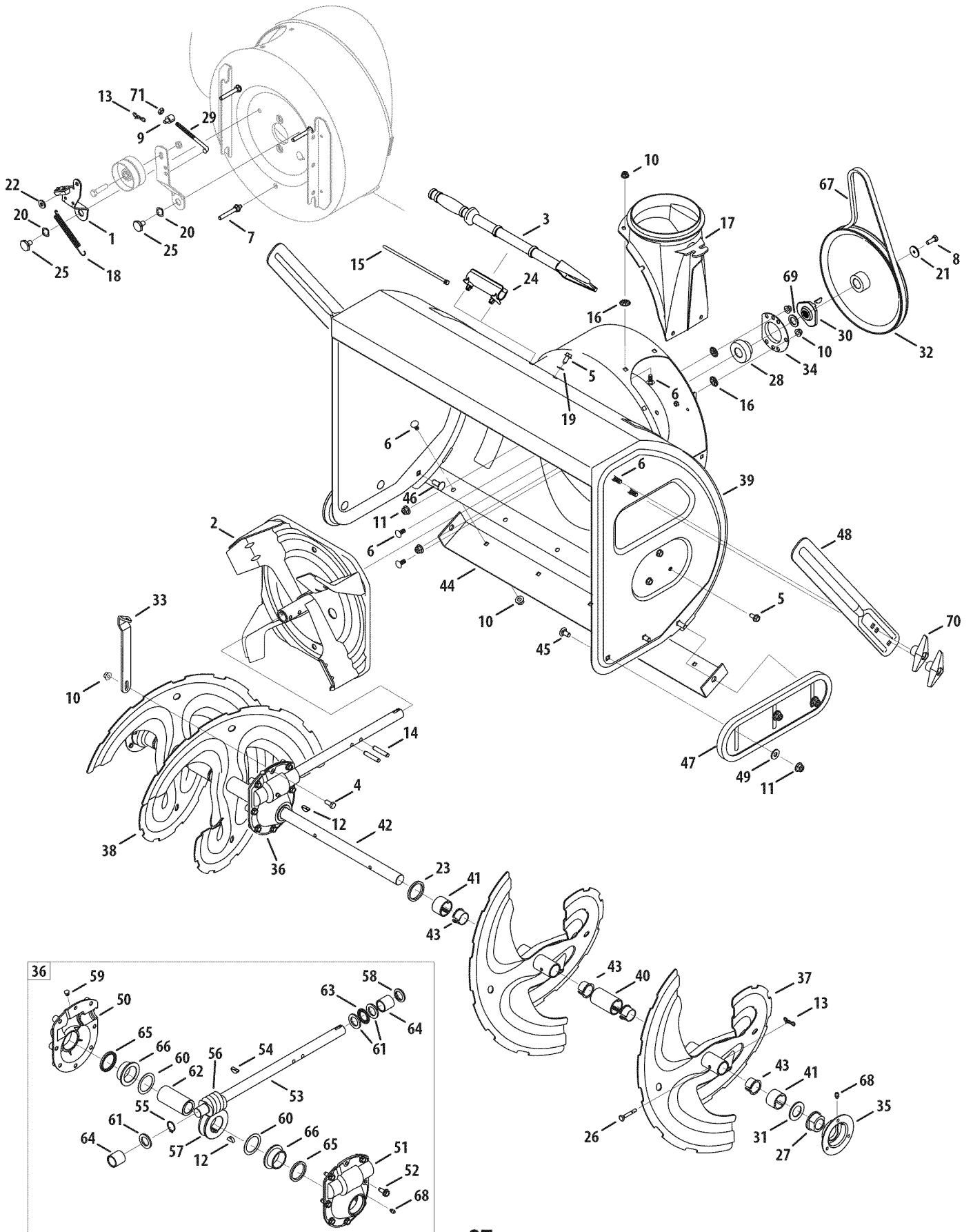

# PARTS LIST

## Craftsman Snow Thrower Model 247.883971

Ref. No.	Part No.	Description
1.	918-0281A	Bracket Assy, Auger Brake
2.	684-0090B-0637	Impellar, 16"
3.	931-2643	Tool, Cleanout
4.	710-0376	Scr,Hex Cap, 5/16-18 x 1.00
5.	710-04484	Screw, 5/16-18 x .750
6.	710-0451	Screw, Carriage, 5/16-18 x .75
7.	710-04606A	Screw, 5/16-18 x .4300
8.	710-1245B	Screw, 5/16-24 x .875
9.	911-0677	Ferrule
10.	712-04063	Nut, Flnge Lk, 5/16-18
11.	712-04065	Nut, Flg Lk, 3/8-16
12.	914-0135	Key, Woodruff,1/4 x 3/4
13.	714-04040	Pin, Bowtie Cotter
14.	915-0118	Pin, Spirol, 5/16 x 1.75
15.	725-0157	Tie, Cable
16.	926-04012	Nut, Push
17.	731-1696B	Adapter, Chute, 6"
18.	732-0858	Spring, Extension
19.	936-0159	Washer, .349 x .879 x .063
20.	736-0174	Washer, .625 x .885 x .015
21.	736-0505	Washer, Flat, .34 x 1.50 x .150
22.	936-3008	Washer, .344 x .75 x .12
23.	736-3046A	Washer, 1.01 x 1.86 x .06
24.	731-2635	Clip, Mounting
25.	938-0281	Screw, Shoulder, .625 x .17
26.	738-04155	Pin, Shear, .25 x 1.75
27.	741-0192	Bearing, Flange w/Flats
28.	941-04024	Bearing, Self Aligning
29.	747-0980A	Rod, Auger Idler
30.	748-04067A	Pulley, Adapter, .75 Dia.
31.	950-04020	Spacer, 1.004 x 1.375 x .25
32.	756-04244A	Pulley, Auger Drive, 10.0
33.	790-00264A-0637	Bracket, Gear Box Support
34.	05244B	Housing, Bearing
35.	784-0315A-0637	Housing, Bearing
36.	918-04514	Gear Box Assembly, Auger

Ref. No.	Part No.	Description
37.	684-04151-4028	Spiral Assy, LH
38.	684-04152-4028	Spiral Assy, RH
39.	684-04214-0691	Housing, Auger - 33"
40.	731-05162	Spacer, 1.0 x 1.5 x 2
41.	731-05163	Spacer, 1.0 x 1.5 x 1
42.	938-04158	Axle, Spiral, 33"
43.	741-0494	Bushing, Flange, 1.051 x 1.16
44.	784-5714B-0637	Shave Plate
45.	710-3168	Bolt, Carriage, 3/8-16 x 1.0
46.	710-3034	Bolt, Carriage, 3/8-16 x 1.25
47.	731-06007	Shoe, Skid
48.	790-00181-0637	Drift Cutter
49.	736-0262	Washer, Flat, .385 x .870
50.	918-0246	Hsg Assy Auger RH (Inc. 65 & 66)
51.	918-0435	Hsg Assy Auger LH (Inc. 65 & 66)
52.	710-1260A	Screw, LD, 5/16-18 x .750
53.	711-04714	Shf, Drive, Auger
54.	914-0126	Key, Hi Pro, 3/16 x 3/4
55.	716-0111	Ext, Ret, Ring
56.	917-0299	Gear, Worm, Dbl Thread
57.	917-1425	Gear, Worm, LH
58.	921-0145	Seal, Oil
59.	721-0325	Plug
60.	936-0266	Washer, Flat, 1.52 ID x 2.0 OD
61.	936-0291	Washer, Flat, .88 ID x .38 OD
62.	738-0275	Shf, Gear, Worm
63.	741-0184	Brg, Thrust
64.	941-0217	Sleeve
65.	921-0146	Oil Seal
66.	741-0670	Flange Bearing
67.	954-04194A	V Belt,4L x 44.60 Lg.
68.	937-3000	Lube Fitting, 3/16 #70
69.	736-0188	Washer, Flat, .78 x 1.49 x .08
70.	720-0284	Wing Knob
71.	712-3007	Jam Nut, 5/16-18
72.		



# PARTS LIST

Craftsman Snow Thrower Model 247.883971

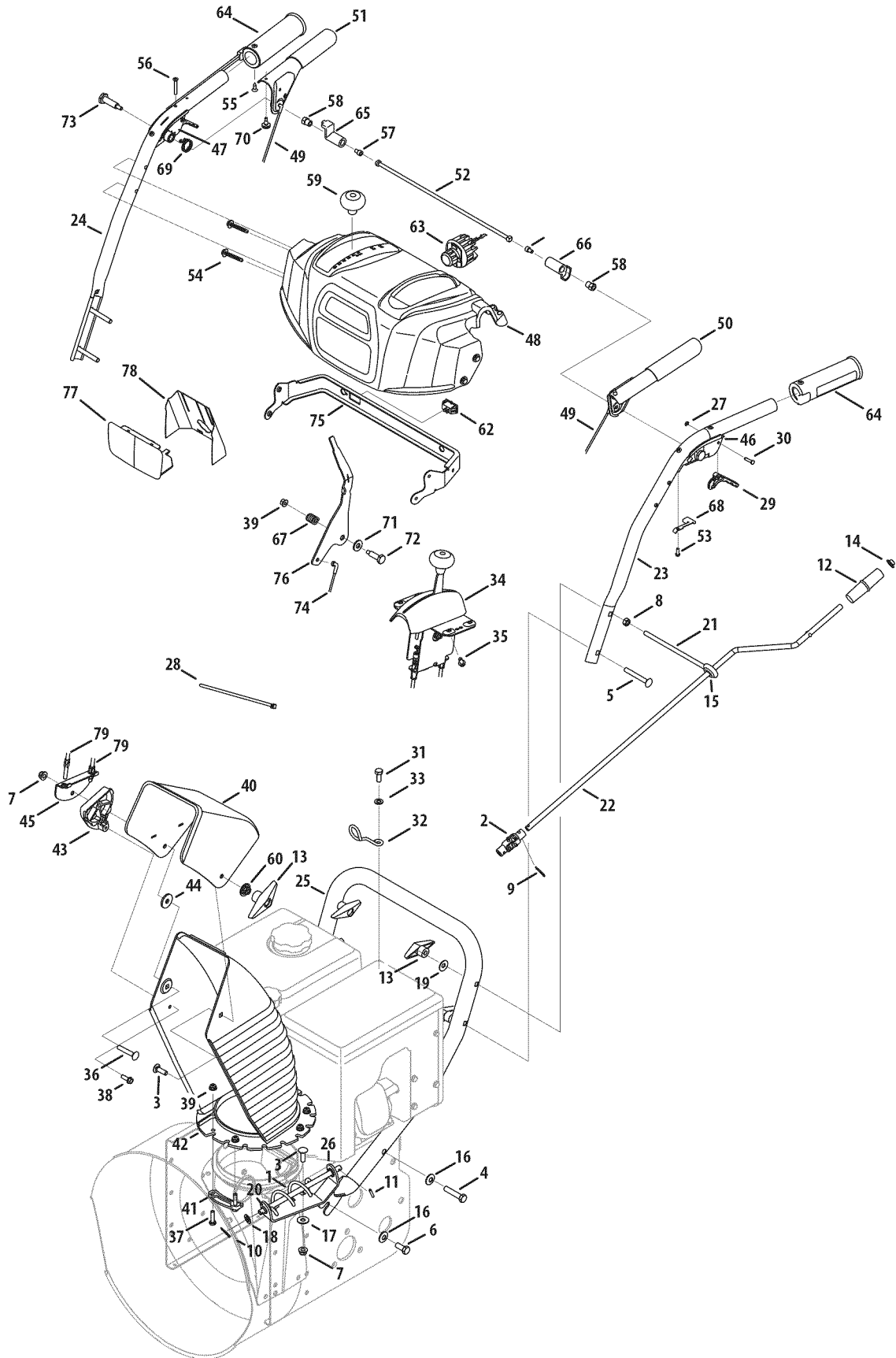

# PARTS LIST

Ref. No.	Part No.	Description
1	684-04308A	Chute Crank Assembly
2	684-04350	Joint Block Assembly
3	710-0276	Screw, Carriage, 5/16-18 x 1.0
4	710-04682	Screw, Hex, 3/8-16 x 2.00 Lock, Gr5
5	710-0572	Screw, Carriage, 5/16-18 x 2.5
6	710-3118	Screw, Hex, 3/8-16 x 1.0 Lock, Gr5
7	712-04063	Flange Lock Nut, 5/16-18
8	912-3010	Hex Nut, 5/16-18
9	914-0101	Internal Cotter Pin
10	914-04040	Internal Cotter Pin
11	715-04095	Spring Pin
12	720-0201A	Knob, Crank
13	720-0284	Knob, Wing Nut, 5/16-18
14	926-0100	Cap, Push, 3/8
15	735-0234	Grommet, Rubber
16	736-0105	Washer, Bel, .375 x .87 x .063
17	936-0159	Washer, Flat, .349 x .879 .063
18	936-0185	Washer, .375 x .738 x .063
19	736-0242	Washer, Belleville, .34 x .872 x .06
20	941-0475	Plastic Bushing, .380 I.D.
21	747-04747	Eye Bolt
22	747-04925A-0637	Chute Rod
23	749-04675-0691	Handle, Upper - LH
24	749-04674-0691	Handle, Upper - RH
25	749-0991-0691	Handle, Lower
26	790-00329-0637	Chute Crank Bracket
27	716-04036	Ring, Retainer
28	725-0157	Cable Tie
29	731-06113	Trigger
30	738-04126	Pin, 3/16
31	710-04022	Hex Head Screw, MB 1.25
32	732-04677	Cable Guide
33	936-0264	Flat Washer, .330 x .630 x .0635
34	984-04230	2-Way Chute Control™ Assy
35	710-04187	Hi-Lo Screw, 1/4-15 x 0.5
36	710-0458	Bolt, Carriage, 5/16-18 x 1.75
37	710-0597	Screw, 1/4-20 x 1.00
38	710-0895	Hi-Lo Screw, 1/4-15 x .75
39	712-04064	Flange Lock Nut, 1/4-20
40	731-0846C	Upper Chute
41	731-0851A	Chute, Flange Keeper

Ref. No.	Part No.	Description
42	731-0903E	Lower Chute
43	731-1313C	Chute Tilt Cable Guide
44	936-0231	Flat Washer
45	784-5594-0637	Cable Bracket
46	631-04133A	Handle Clutch Lock - LH
47	631-04134B	Handle Clutch Lock - RH
48	931-04187A	Handle Panel
49	646-0012	Cable Assembly, Auger/Drive
	746-0952	Cable, Clutch
	732-0184	Spring, Extension
50	684-04111B	Handle Engage Assy - LH
51	684-04112C	Handle Engage Assy - RH
52	684-04250	Rod Ass'y, Clutch Lock Pivot
53	710-04326	Screw, #8-16 x 0.50
54	710-04586	Screw, 1/4-20 x 1.625
55	710-0837	AB Screw, #10-16
56	710-1233	Screw, #10-24 x 0.375
57	710-3069	Screw, 1/4-20 x.375
58	712-04081A	Shoulder Nut, 1/4-20
59	720-04039	Shift Knob
60	736-0159	Flat Washer, .349 x .879 x .063
61	725-05148	Wiring Harness <i>(Not Shown)</i>
62	725-04393	Htd. Hand Grip on/off Switch
63	725-06095	Light Socket
64	725-05149	Heated Hand Grip
65	731-04894D	Lock Plate
66	731-04896B	Clutch Lock Cam
67	732-0193	Compression Spring
68	732-04219C	Clutch Lock Spring
69	732-04238	Torsion Spring
70	935-0199A	Rubber Bumper
71	936-0267	Flat Washer, .385 x .87 x .06
72	738-04125	Shoulder Screw
73	738-04348	Shoulder Screw, 1/4-20 x 1.345
74	746-04341	Speed Selector Cable
75	790-00248C-0637	Panel Bracket
76	790-00281B-0637	Shift Lever
77	731-05324	Lens Panel
78	777X41804	Reflector Label
79	746-04338	Cable, Chute Tilt

# PARTS LIST

Craftsman Snow Thrower Model 247.883971

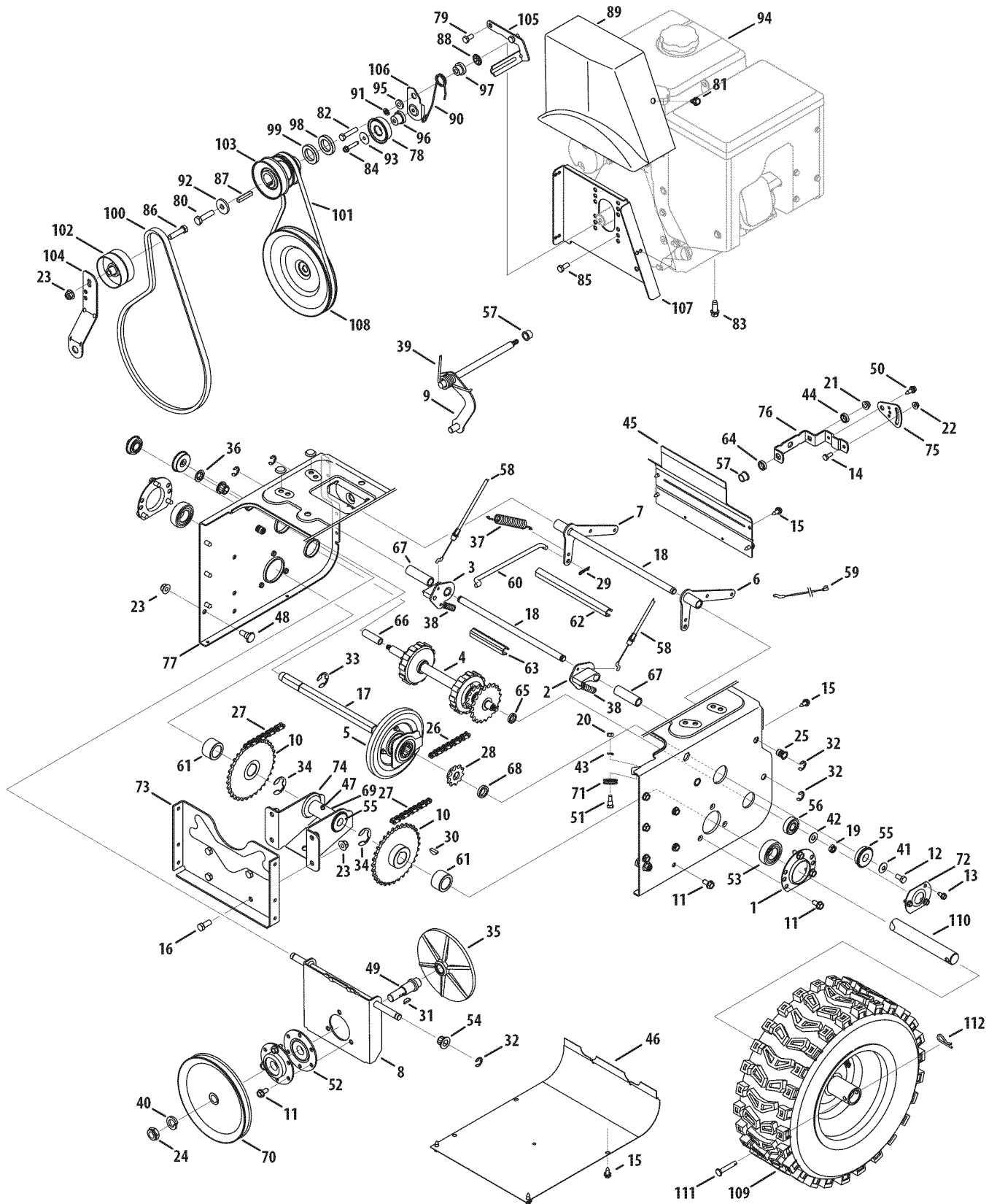

# PARTS LIST

## Craftsman Snow Thrower Model 247.883971

Ref. No.	Part No.	Description
1.	05244B	Housing, Bearing
2.	618-0279P	Dogg, Steering Drive, LH
3.	618-0280P	Dogg, Steering Drive, RH
4.	918-0282E	Shaft Assembly, Steering
5.	918-04178	Assembly, Friction Wheel
	718-04034	Wheel, Friction, Bonded
	710-0896	Screw, Hex Wash
6.	684-0118B-0637	Bracket, Auger Actuator
7.	684-0119B-0637	Bracket, Drive Actuator
8.	684-04212-0637	Brkt, Friction Drive Suprt.
9.	684-04229	Rod Assembly, Shift
10.	684-04235	Sprocket, 32T
11.	710-04484	TT Screw, 5/16-18 x .750
12.	710-0538	Screw, Hex Cap Lock,
13.	710-0599	Hex Screw, 1/4-20 x .50
14.	710-0751	Hex Head Screw, 1/4-20
15.	710-1652	Screw, Hex Wash.
16.	710-3001	Screw, Hex Cap, 3/8-16
17.	911-04279	Shaft, Hex Drive
18.	711-04605	Shaft, Actuator
19.	912-0116	Nut, Hex Insert Jam Lock
20.	912-0138	Nut, Hex, 1/4-28 GR5
21.	712-04063	Flange Lock Nut, 5/16-18
22.	712-04064	Flange Lock Nut, 1/4-20
23.	712-04065	Flange Lock Nut, 3/8-16
24.	912-0413	Hex Nut, 5/8-18
25.	712-0717	Nut, Insert 3/8-16
26.	713-0284	Chain, Endless, #41 x 36L
27.	713-0286	Chain, #420 x 40L
28.	913-04015	Sprocket, #41 x 10T
29.	914-0104	Pin, Internal Cotter
30.	914-0135	Key, Woodruff
31.	914-0388	Key, Hi-Pro, 3/16 x 5/8
32.	916-0104	E-Ring
33.	716-0136	Ring, Retaining
34.	716-04048	Ring, Retainer
35.	917-0302	Plate, Drive
36.	726-0221	Speed Nut, .500
37.	932-0121	Spring, Extension
38.	932-0209	Spring, Extension

Ref. No.	Part No.	Description
39.	732-04385	Torsion Spring, .750 I.D. x .968 Lg.
40.	936-0158	Washer, Lock, 5/8
41.	736-0242	Wsh, Bell., .34 x .872 x .06
42.	936-0864	Wash, .375 x .812 x .060
43.	936-0329	Washer, Lock, 1/4
44.	936-3015	Flat Washer, .469 x .875 x .105
45.	790-00257-0691	Cover, Upper Frame
46.	790-00259-0691	Cover, Lower Frame
47.	937-3000	Fitting, Lube, 3/16 Drive
48.	738-0143	Screw, Shldr., .498 x .34
49.	738-0279	Spindle, Drive Plate
50.	738-04184A	Shoulder Screw, .368 x .113, 1/4-20
51.	738-0924A	Screw, Hex Shldr., 1/4-28
52.	741-0163A	Ass'y, Bearing/Housing
53.	941-04025	Bearing, Self Aligning
54.	741-04108	Bearing, Hex Flange
55.	941-0563	Bearing, Ball
56.	741-0747	Bush, Flg, .5625 x 1.375 x .4375
57.	741-0748	Bush, Flg, .5 ID x .627 OD
58.	746-04337A	Steering Cable, 35.97" Long
59.	946-0951A	Cable, Auger Idler
60.	747-0973	Rod, Drive Clutch
61.	750-04703	Spcr., 1.0 ID x 1.50 OD
62.	750-04717	Spcr., .51 ID x 7.895 Lg.
63.	750-04718	Spcr., .51 ID x 3.66 Lg.
64.	750-04719	Spcr., .5151 ID x .750 OD x .220
65.	750-05342	Spcr., .566 ID x .87 OD x .190
66.	750-05343	Spcr., .566 ID x .87 OD x 1.25
67.	750-0903B	Spcr., .514 x .632 x 2.44
68.	950-0997	Spacer, .675 x 1.0 x .23
69.	750-1302B	Spcr, .6725 x 1.125 x 2.48
70.	756-0344	Pulley, Auger
71.	756-0625	Roller, Cable
72.	784-0404	Bearing Retaining Bracket
73.	784-0406A-0637	Bracket, Frame Support
74.	784-0407-0637	Bracket, Axle Support
75.	790-00217A-0637	Speed Selector Pivot Bracket
76.	790-00218A-0637	Speed Selector Shift Bracket
77.	790-00349-0691	Transmission Frame
78.	684-04169	Idler Pulley Assembly

Continued on following page

# PARTS LIST

## Craftsman Snow Thrower Model 247.883971

Continued from previous page

Ref. No.	Part No.	Description
79.	710-0627	Screw, Hex Cap, 5/16-24
80.	710-0191	Hex Hd. Screw, 3/8-24 x 1.25 GR8
81.	710-0607	Screw, Hx Wash Hd Tapp
82.	710-0624	Screw, Hex Cap, 5/16-24 x 1.50
83.	710-0654A	Screw, 3/8-16 x 1.00
84.	710-0809	Screw, 1/4-20 x 1.25
85.	738-04439	Hex Head Screw, 5/16-24 x .875
86.	710-0347	Hex Head Screw, 3/8-16 x 1.75
87.	914-0105	Square Key, 3/16 x 1.00
88.	926-04012	Nut, Push
89.	931-2531	Cover, Belt
90.	732-04308A	Torsion Spring, .850 dia. x .333 lg.
91.	936-0119	Washer, Lock, 5/16
92.	736-3082A	Washer, Flat, .45 x 1.5 x .172
93.	736-3092	Washer, Flat, .265 x 1.0 x .030
94.	952Z483-SU	Engine Complete
95.	748-04112B	Shoulder Spacer, .3175 x .500 x .094
96.	750-04571	Shoulder Spacer, .260 x .785 x .538
97.	750-04821	Shoulder Spacer, .340 x 1.00
98.	750-05316	Spacer, 1.155 ID x 1.78 OD x .150
99.	750-05318	Spacer, 1.004 ID x 1.625 OD x .50
100.	954-04194A	V-Belt, 4L x 44.60 Lg.
101.	954-04202	V Belt, 3/8 x 36.68
102.	756-0981B	Pulley, Flat Idler, 2.75 OD
103.	756-04351	Double Pulley, 3.25 x 2.75
104.	784-0385D	Bracket, Auger Idler
105.	790-00167A-0637	Belt Keeper Bracket
106.	790-00208C	Idler Drive Wheel Bracket
107.	790-00254A-0637	Belt Cover Bracket
108.	756-0344	Pulley, Drive
109.	634-0225A-0911	Wheel Ass'y. - LH
	634-0226A-0911	Wheel Ass'y. - RH
	734-2031	Tire
	934-0255	Valve
	741-0246A	Bearing
110.	711-04607A	Axle, Wheel, 33"
111.	711-04615	Pin, Clevis
112.	914-0149B	Pin, Internal Cotter

# PARTS LIST

Craftsman Snow Thrower Model 247.883971

777S32636

AVOID INJURY FROM ROTATING AUGER - KEEP HANDS, FEET AND CLOTHING AWAY



DANGER

DANGER

1. KEEP AWAY FROM ROTATING IMPELLER AND AUGER. CONTACT WITH IMPELLER OR AUGER CAN AMPUTATE HANDS AND FEET.
2. USE CLEAN-OUT TOOL TO UNCLOG DISCHARGE CHUTE.
3. DISENGAGE CLUTCH LEVERS, STOP ENGINE, AND REMAIN BEHIND HANDLES UNTIL ALL MOVING PARTS HAVE STOPPED BEFORE UNCLOGGING OR SERVICING MACHINE.
4. TO AVOID THROWN OBJECTS INJURIES, NEVER DIRECT DISCHARGE AT BYSTANDERS. USE EXTRA CAUTION WHEN OPERATING ON GRAVEL SURFACES.
5. READ OPERATOR'S MANUAL.

CLEAN-OUT TOOL



777I22341

CHUTE DIRECTIONAL CONTROL

DISCHARGE LEFT



DISCHARGE RIGHT



CHUTE TILT DOWN



CHUTE TILT UP



STARTING INSTRUCTIONS:

- 1.) INSERT KEY AND SNAP IN PLACE.
- 2.) MOVE THROTTLE CONTROL TO THE "FAST" POSITION.
- 3.) MOVE CHOKE CONTROL TO THE "CHOKE" POSITION. PUSH PRIMER 3x.
- 4.) ROPE START: PULL SLOWLY UNTIL HARDER TO PULL, THEN PULL RAPIDLY TO START. REPEAT PRIMING IF NEEDED.  
ELECTRIC START: DO NOT USE IN RAIN. CONNECT POWER CORD AND PUSH STARTER BUTTON. REPEAT PRIMING IF NEEDED.
- 5.) MOVE CHOKE CONTROL SLOWLY TO THE "RUN" POSITION.
- 6.) TO STOP ENGINE: MOVE THROTTLE TO THE "STOP" POSITION.

I22341 AC

777D16340



777I23013

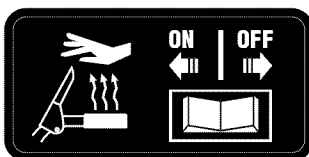

777D19077



777I22340

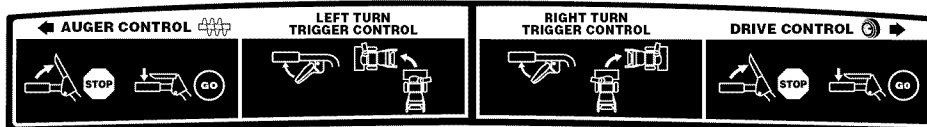

777D18037



777S32280

DANGER



- NEVER PUT HAND IN CHUTE. CONTACT WITH ROTATING PARTS CAN AMPUTATE FINGERS AND HANDS.
- SHUT OFF ENGINE AND WAIT UNTIL ALL MOVING PARTS HAVE STOPPED BEFORE UNCLOGGING.
- USE CLEAN-OUT TOOL OR WOODEN STICK TO UNCLOG DISCHARGE CHUTE.

777I22363



777D18046



# PARTS LIST

Craftsman Engine Model 483-SUB For Snow Model 247.883971

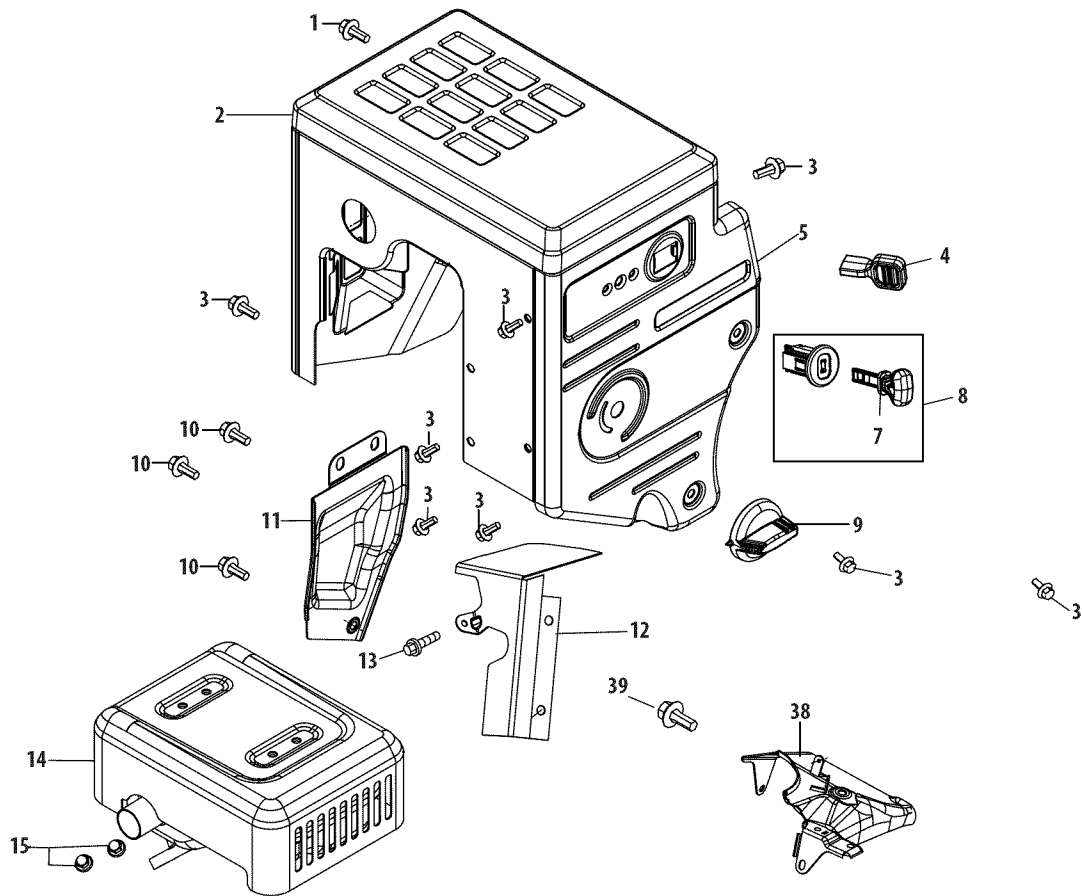

Ref.	Part No.	Description
1	710-04915	Bolt M6×12
2	951-11339	Muffler Shield
3	710-04915	Bolt M6×12
4	951-10757	Throttle Control Knob
5	951-11595	Control Panel
7	731-05632	Key
8	951-10637	Key Switch Assembly
9	951-11302	Choke Knob
10	710-04914	Bolt M6×10
11	951-11181	Exhaust Pipe Shield
12	951-11321	Carburetor Heat Shield
13	710-04968	Bolt M6×16
14	951-11338	Muffler Assembly
15	712-05015	Nut, M8
38	951-11311	Throttle Control Assembly
39	710-04915	Bolt M6×12

# PARTS LIST

Craftsman Engine Model 483-SUB For Snow Model 247.883971

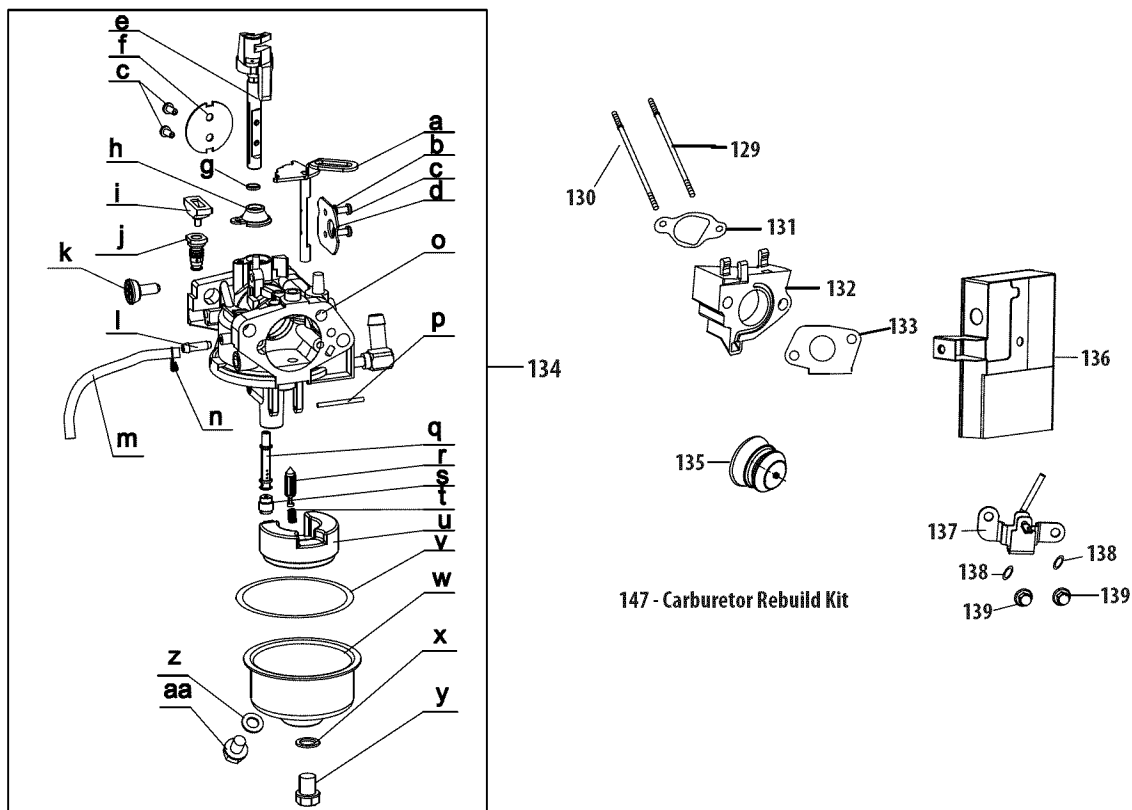

Ref.	Part No.	Description
129	710-05392	Stud M6-8x100
130	710-05056	Stud M6-8x118
131	951-11315	Carburetor Intake Gasket
132	951-11316	Carburetor Insulator
133	951-11223	Carburetor Gasket
134	951-14023A	Carburetor Assembly
135	951-10639A	Primer Assembly
135	951-11824	Primer Bulb
136	951-11304	Heater Box
137	951-11192	Choke Assembly
138	736-04477	Lock Washer
139	712-05015	Nut M6
147	951-12760A	Carburetor Rebuild Kit (Inc.i,j,p,q,r,s,t,u,v,x,z)
a	n/a	Choke Shaft
b	736-04638	Choke Control Lever Washer
c	710-05469	Fuel Shutoff Lever Screw
d	n/a	Choke Plate
e	n/a	Throttle Shaft
f	n/a	Throttle Plate
g	n/a	Gasket

Ref.	Part No.	Description
h	n/a	Throttle Shaft Cover
i	n/a	Idle Jet Rivet
j	n/a	Idle Jet Assembly
k	n/a	Idle Speed Adjusting Screw
l	n/a	Primer Pipe
m	751-11991	Primer Hose
n	951-11906	Primer Hose Clamp
o	n/a	Carburetor Body
p	n/a	Float Pin
q	n/a	Emulsion Tube
r	n/a	Nickel Plated Brass Needle Valve
s	n/a	Main Jet
t	n/a	Needle Valve Spring
u	n/a	Float
v	951-11970	Fuel Bowl Gasket
w	n/a	Fuel Bowl
x	951-11348	Fuel Bowl Gasket
y	710-04945	Fuel Bowl Mounting Bolt
z	951-11349	Fuel Drain Plug Gasket
aa	710-04938	Fuel Drain Plug



# PARTS LIST

Craftsman Engine Model 483-SUB For Snow Model 247.883971

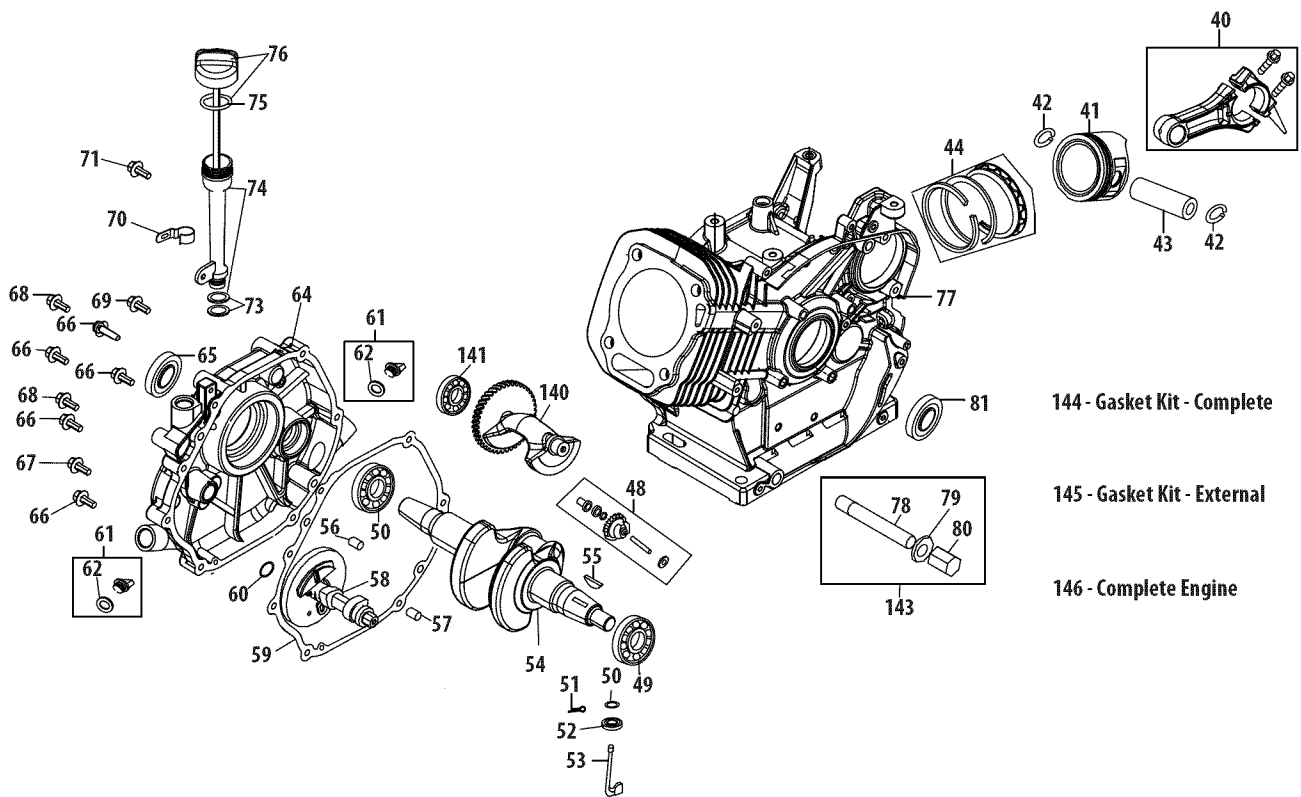

144 - Gasket Kit - Complete

145 - Gasket Kit - External

146 - Complete Engine

# PARTS LIST

Craftsman Engine Model 483-SUB For Snow Model 247.883971

Ref.	Part No.	Description	Ref.	Part No.	Description
40	951-11951	Connecting Rod Assembly	67	710-06062	Bolt M8x45
41	951-11952	Piston	68	710-06063	Bolt M8x35
42	951-11953	Piston Pin Snap Ring	69	710-04968	Bolt M6x16
43	951-11954	Piston Pin	70	951-11320	Oil Tube Support Bracket
44	951-12579	Piston Ring Set	71	710-05349	Bolt M6x8
48	951-11956	Governor Gear/Shaft Assembly	73	951-11381	Oil Fill Tube O-Ring
49	951-11373	Radial Ball Bearing	74	951-12073	Oil Fill Tube Assembly
50	736-04453	Flat Washer	75	951-11904	Dipstick O-Ring
51	714-04077	Governor Shaft Clip	76	951-11971A	Dipstick Assembly
52	951-11958	Governor Seal	77	951-11341A	Crankcase Kit (Inc.49,52,77,81)
53	951-11365	Governor Arm Shaft		951-11328B	Short Block Assembly
54	951-11342	Crankshaft Kit (Inc.49,54,55,65,81)			(Inc.40-44,48-68,77-81,102,105,106,108 110,111, 125,131,132,140,141)
55	951-10307	Woodruff Key	78	951-11350	Oil Drain Pipe
56	715-04102	Dowel Pin 9 X 12	79	736-04440	Drain Pipe Washer 10X16X1.5
57	715-04092	Dowel Pin 7 X 14	80	710-04906	Oil Drain Plug Bolt
58	951-11959	Camshaft Assembly	81	951-11499	Oil Seal
59	951-11376	Crankcase Cover Gasket	140	951-11968	Balance Gear Assembly
60	736-04545	Washer	141	951-11969	Bearing
61	951-11283	Oil Fill Plug Assembly	143	951-10641	Oil Drain Asm
62	951-11577	O-Ring	144	951-11330A	Gasket Kit - Complete
64	951-14220	Crankcase Cover			(Inc.52,59,65,79,81,106, 108,125,131-133)
	951-11340	Crankcase Cover Kit (Inc.49,59,60,64-68)	145	951-11331	Gasket Kit - External
65	951-11375	Oil Seal			(Inc.79,108,125,131-133)
66	710-06061	Bolt M8x38	146	952Z483-SUB	Complete Engine

# PARTS LIST

Craftsman Engine Model 483-SUB For Snow Model 247.883971

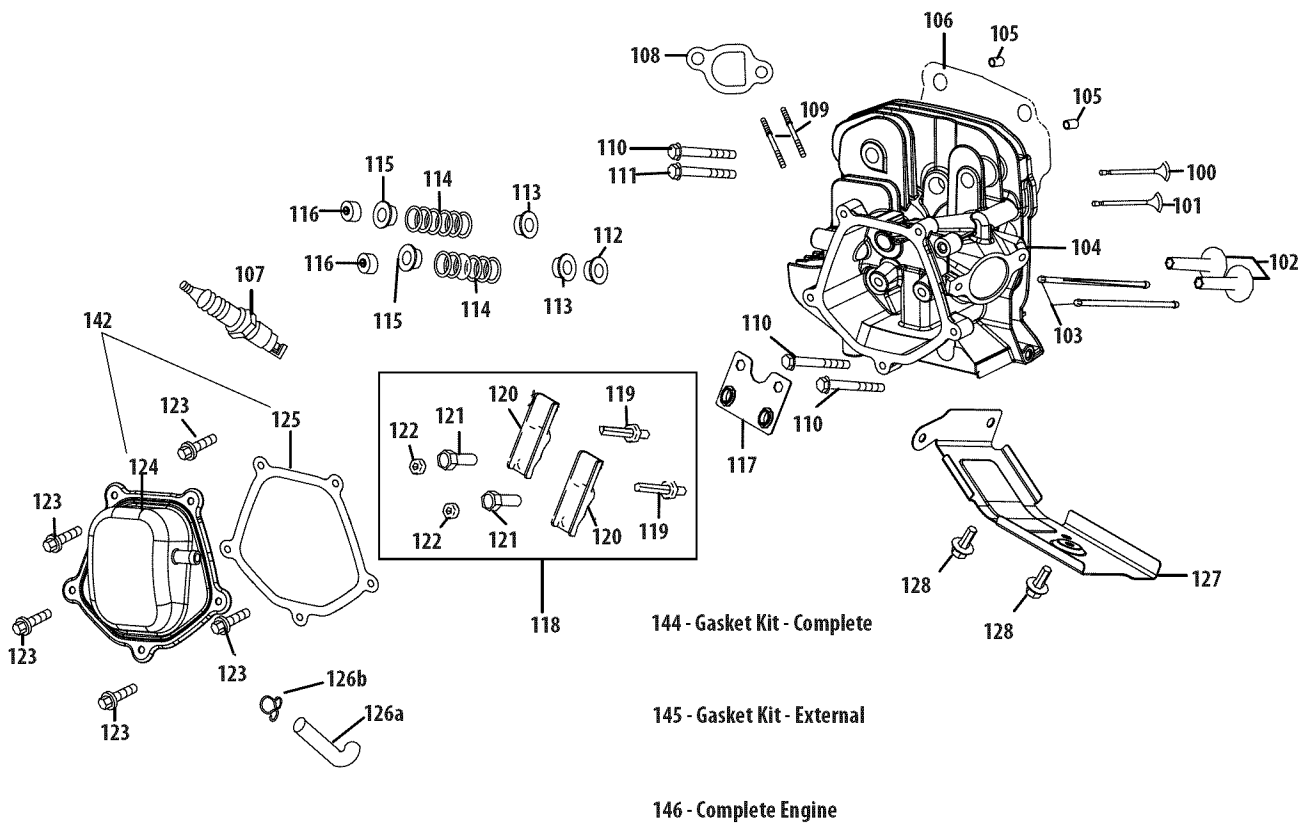

# PARTS LIST

## Craftsman Engine Model 483-SUB For Snow Model 247.883971

Ref.	Part No.	Description	Ref.	Part No.	Description
100	951-11337	Valve Kit	116	951-12081	Exhaust Lash Cap
101	951-11337	Valve Kit	117	951-11965	Push Rod Guide
102	951-11962	Tappet	118	951-11981	Rocker Arm Assembly
103	951-11335	Push Rod Kit	119	710-04962	Bolt, Pivot
104	951-12555	Cylinder Head Kit (Inc.106,110-112,125)	120	951-11966	Rocker Arm
	951-11329B	Cylinder Head Assembly (Inc.100,101,104,106,108-112, 114-122,125,129-133)	121	751-11123	Adjusting Nut ,Valve
105	715-04097	Dowel Pin	122	751-11124	Pivot Locking Nut
106	951-11963	Cylinder Head Gasket	123	710-05054	Valve Cover Bolt
107	951-10292	Spark Plug/F6Rtc	124	951-11220	Valve Cover
108	951-11212	Muffler Gasket	125	951-11967	Valve Cover Gasket
109	710-04964	Exhaust Stud M8x48.5	126a	731-07059	Breather Hose
109	951-11207	Muffler Stud Assembly	126b	726-04101	Breather Hose Clamp
110	710-06064	Bolt M10x1.25x87	127	951-11317	Cylinder Baffle
111	710-06065	Bolt M10x1.25x65	128	710-04915	Bolt M6x12
112	951-11964	Intake Valve Seal	142	951-11333	Valve Cover Kit
113	951-12077	Intake Valve Spring Retainer	144	951-11330A	Gasket Kit - Complete (Inc.52,59,65,79,81,106,108,125,131-133)
114	951-12078	Valve Spring	145	951-11331	Gasket Kit - External (Inc.79,108,125,131-133)
115	951-12080	Exhaust Valve Spring Retainer	146	952Z483-SUB	Complete Engine

# PARTS LIST

Craftsman Engine Model 483-SUB For Snow Model 247.883971

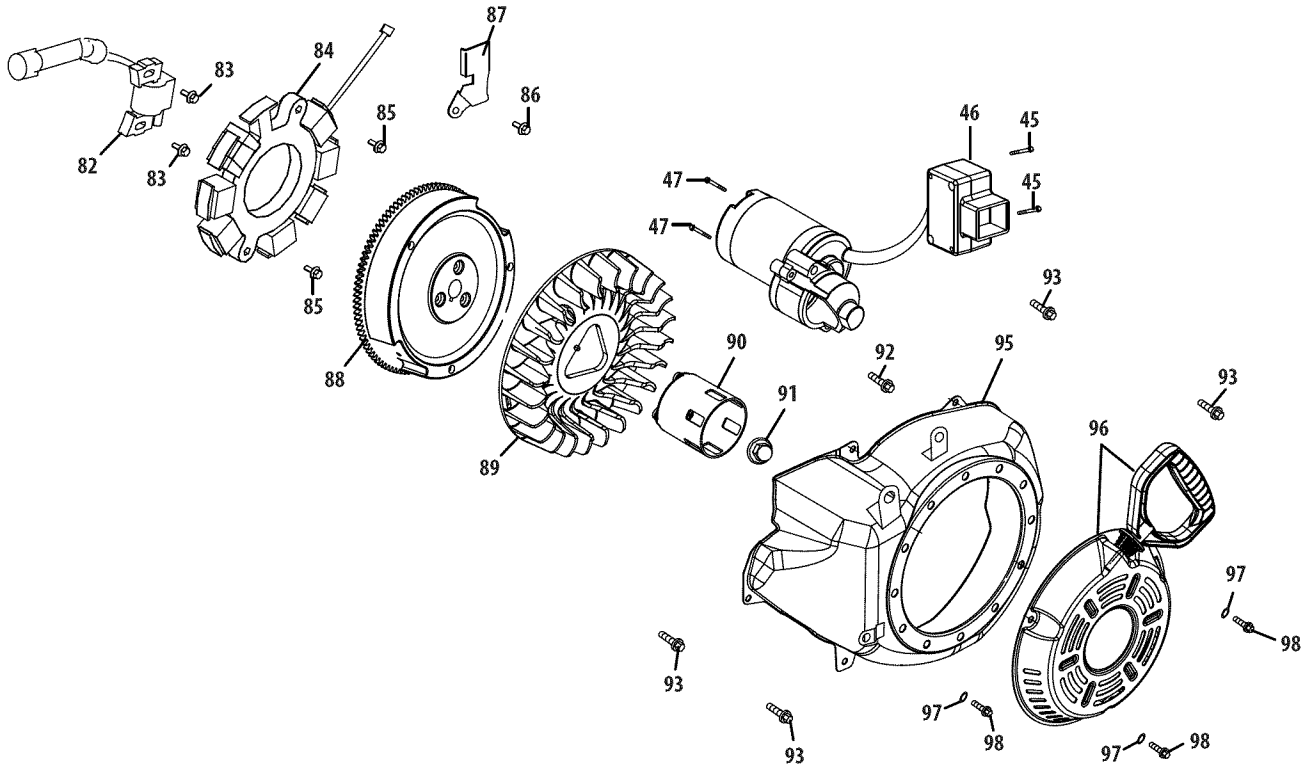

Ref.	Part No.	Description
45	710-04965	Screw M4 X 55
46	951-11196	Electric Starter
47	710-04967	Bolt M8×55
82	951-11305	Ignition Coil Assembly
83	710-05350	Ignition Coil Bolt
84	951-12553	Alternator Assembly
85	710-04969	Bolt M6×30
86	710-04966	Bolt M6×8
87	951-11186	Alternator Wire Clamp Bracket
88	951-12556	Flywheel

Ref.	Part No.	Description
89	951-11313	Cooling Fan
90	951-11314	Starter Cup
91	712-04220	Flywheel Nut, M14×1.5
92	710-04968	Bolt M6×16
93	710-04915	Bolt M6×12
95	951-11211	Blower Housing
96	951-14223	Recoil Starter Assembly
97	736-04455	Flat Washer
98	710-04974	Bolt M6×10

# PARTS LIST

Craftsman Engine Model 483-SUB For Snow Model 247.883971

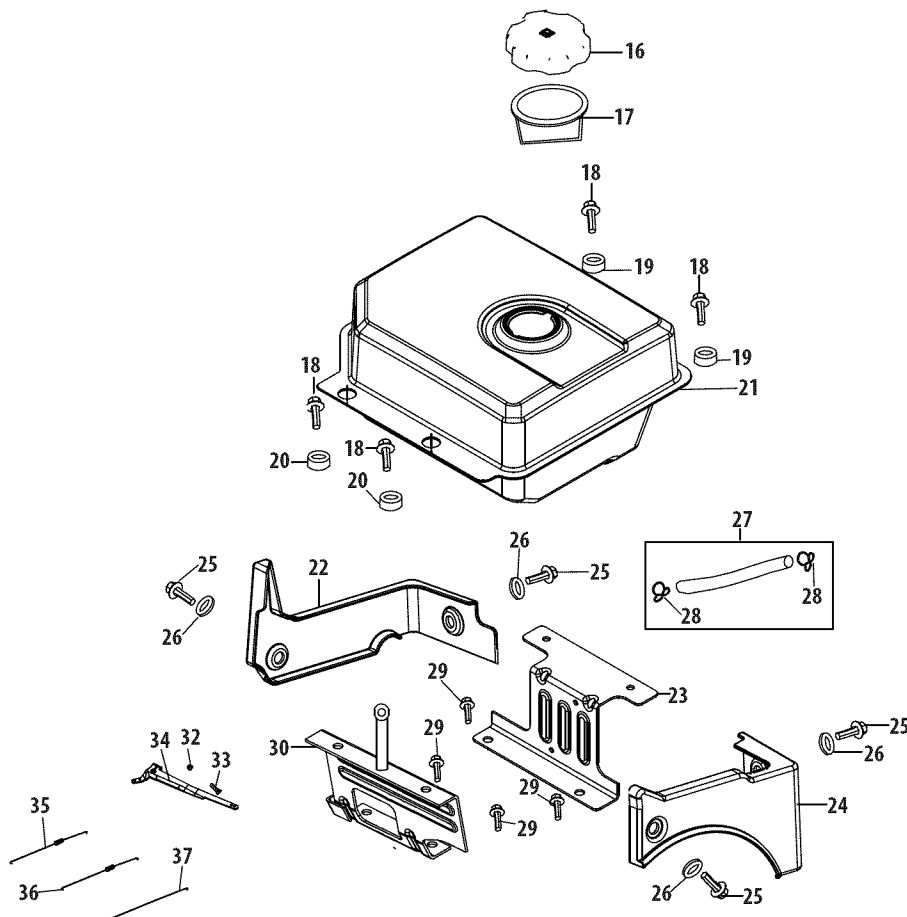

Ref.	Part No.	Description
16	951-12533	Fuel Cap Assembly
17	951-11933	Fuel Level Indicator
18	710-04970	Bolt M8x20
19	750-05312	Bushing, Slot
20	750-05313	Bushing, Rnd
21	951-11201	Fuel Tank Assembly
22	951-11319	Fuel Tank Shroud
23	951-11318	Fuel Tank Mounting Bracket
24	951-11351	Engine Shroud
25	710-04968	Bolt M6x16
26	736-04452	Bush

Ref.	Part No.	Description
27	951-11336	Fuel Line Kit
28	951-11700	Fuel Hose Clamp
29	710-04921	Bolt M8x14
30	951-11182	Fuel Tank Mounting Bracket
32	712-04212	Flange Nut M6
33	710-04908	Governor Arm Bolt M6X21
34	951-11307	Governor Arm
35	951-11306	Governor Spring
36	951-11203	Throttle Return Spring
37	951-11309	Governor Rod

**FEDERAL and/or CALIFORNIA EMISSION CONTROL WARRANTY STATEMENT**  
**YOUR WARRANTY RIGHTS AND OBLIGATIONS**

MTD Consumer Group Inc, the United States Environmental Protection Agency (EPA), and for those products certified for sale in the state of California, the California Air Resources Board (CARB) are pleased to explain the emission (evaporative and/or exhaust) control system (ECS) warranty on your 2013 and later small off-road spark-ignited engine and equipment (outdoor equipment engine). In California, new outdoor equipment engines must be designed, built and equipped to meet the State's stringent anti-smog standards (in other states, outdoor equipment engines must be designed, built, and equipped to meet the U.S. EPA small off-road spark ignition engine regulations). MTD Consumer Group Inc must warrant the ECS on your outdoor equipment engine for the period of time listed below, provided there has been no abuse, neglect, or improper maintenance of the outdoor equipment engine.

Your ECS may include parts such as the carburetor, fuel-injection system, ignition system, catalytic converter, fuel tanks, fuel lines, fuel caps, valves, canisters, filters, vapor hoses, clamps, connectors, and other associated emission-related components.

Where a warrantable condition exists, MTD Consumer Group Inc will repair your outdoor equipment engine at no cost to you including diagnosis, parts, and labor.

**MANUFACTURER'S WARRANTY COVERAGE:**

This emission control system is warranted for two years. If any emission-related part on your outdoor equipment engine is defective, the part will be repaired or replaced by MTD Consumer Group Inc. In the event that a component is covered for longer than two years by the Manufacturer's equipment warranty, the longer coverage period will apply.

**OWNER'S WARRANTY RESPONSIBILITIES:**

As the outdoor equipment engine owner, you are responsible for performance of the required maintenance listed in your owner's manual. MTD Consumer Group Inc recommends that you retain all receipts covering maintenance on your outdoor equipment engine, but MTD Consumer Group Inc cannot deny warranty solely for the lack of receipts.

As the outdoor equipment engine owner, you should however be aware that MTD Consumer Group Inc may deny you warranty coverage if your outdoor equipment engine or a part has failed due to abuse, neglect, improper maintenance, or unapproved modifications.

You are responsible for presenting your outdoor equipment engine to MTD Consumer Group Inc's distribution center or service center as soon as the problem exists. The warranty repairs should be completed in a reasonable amount of time, not to exceed 30 days. If you have a question regarding your warranty coverage, you should contact the MTD Consumer Group Inc Service Department at 1-800-800-7310 or at <http://support.mtdproducts.com>.

**GENERAL EMISSIONS WARRANTY COVERAGE:**

MTD Consumer Group Inc warrants to the ultimate purchaser and each subsequent purchaser that the outdoor equipment engine is: (1) designed, built, and equipped so as to conform with all applicable regulations; and (2) free from defects in materials and workmanship that cause the failure of a warranted part for a period of two years.

The warranty period begins on the date the outdoor equipment engine is delivered to an ultimate purchaser or first placed into service.

Subject to certain conditions and exclusions as stated below, the warranty on emission-related parts is as follows:

1. Any warranted part that is not scheduled for replacement as required maintenance in the written instructions supplied is warranted for the warranty period stated above. If the part fails during the period of warranty coverage, the part will be repaired or replaced by MTD Consumer Group Inc according to subsection (4) below. Any such part repaired or replaced under warranty will be warranted for the remainder of the period.
2. Any warranted part that is scheduled only for regular inspection in the written instructions supplied is warranted for the warranty period stated above. Any such part repaired or replaced under warranty will be warranted for the remaining warranty period.
3. Any warranted part that is scheduled for replacement as required maintenance in the written instructions supplied is warranted for the period of time before the first scheduled replacement date for that part. If the part fails before the first scheduled replacement, the part will be repaired or replaced by MTD Consumer Group Inc according to subsection (4) below. Any such part repaired or replaced under warranty will be warranted for the remainder of the period prior to the first scheduled replacement point for the part.
4. Repair or replacement of any warranted part under the warranty provisions herein must be performed at a warranty station at no charge to the owner.
5. Notwithstanding the provisions herein, warranty services or repairs will be provided at all of our distribution centers that are franchised to service the subject engines or equipment.
6. The outdoor equipment engine owner will not be charged for diagnostic labor that is directly associated with diagnosis of a defective, emission-related warranted part, provided that such diagnostic work is performed at a warranty station.
7. MTD Consumer Group Inc is liable for damages to other engine or equipment components proximately caused by a failure under warranty of any warranted part.
8. Throughout the off-road engine and equipment warranty period stated above, MTD Consumer Group Inc will maintain a supply of warranted parts sufficient to meet the expected demand for such parts.
9. Any replacement part may be used in the performance of any warranty maintenance or repairs and must be provided without charge to the owner. Such use will not reduce the warranty obligations of MTD Consumer Group Inc.

- 
10. Add-on or modified parts that are not exempted by the Air Resources Board may not be used. The use of any non-exempted add-on or modified parts by the ultimate purchaser will be grounds for disallowing a warranty claims. MTD Consumer Group Inc will not be liable to warrant failures of warranted parts caused by the use of a non-exempted add-on or modified part.

### **WARRANTED PARTS:**

The repair or replacement of any warranted part otherwise eligible for warranty coverage may be excluded from such warranty coverage if MTD Consumer Group Inc demonstrates that the outdoor equipment engine has been abused, neglected, or improperly maintained, and that such abuse, neglect, or improper maintenance was the direct cause of the need for repair or replacement of the part. That notwithstanding, any adjustment of a component that has a factory installed, and properly operating, adjustment limiting device is still eligible for warranty coverage. Further, the coverage under this warranty extends only to parts that were present on the off-road engine and equipment purchased.

The following emission warranty parts are covered (if applicable):

1. Fuel Metering System
  - Cold start enrichment system (soft choke)
  - Carburetor and internal parts (or fuel injection system)
  - Fuel pump
  - Fuel tank
2. Air Induction System
  - Air cleaner
  - Intake manifold
3. Ignition System
  - Spark plug(s)
  - Magneto ignition system
4. Exhaust System
  - Catalytic converter
  - SAI (Reed valve)
5. Miscellaneous Items Used in Above System
  - Vacuum, temperature, position, time sensitive valves and switches
  - Connectors and assemblies
6. Evaporative Control
  - Fuel hose
  - Fuel hose clamps
  - Tethered fuel cap
  - Carbon canister
  - Vapor lines



## Look For Relevant Emissions Durability Period and Air Index Information On Your Engine Emissions Label

Engines that are certified to meet the California Air Resources Board (CARB) Tier 2 Emission Standards must display information regarding the Emissions Durability Period and the Air Index. Sears Brands Management Corporation makes this information available to the consumer on our emission labels.

The Emissions Durability Period describes the number of hours of actual running time for which the engine is certified to be emissions compliant, assuming proper maintenance in accordance with the Operating & Maintenance Instructions. The following categories are used:

**Moderate:** Engine is certified to be emission compliant for 125 hours of actual engine running time.

**Intermediate:** Engine is certified to be emission compliant for 250 hours of actual engine running time.

**Extended:** Engine is certified to be emission compliant for 500 hours of actual engine running time.

For example, a typical walk-behind lawn mower is used 20 to 25 hours per year. Therefore, the **Emissions Durability Period** of an engine with an **intermediate** rating would equate to 10 to 12 years.

The **Air Index** is a calculated number describing the relative level of emissions for a specific engine family. The lower the **Air Index**, the cleaner the engine. This information is displayed in graphical form on the emissions label.

### After July 1, 2000, Look For Emissions Compliance Period On Engine Emissions Compliance Label

After July 1, 2000 certain Sears Brands Management Corporation engines will be certified to meet the United States Environmental Protection Agency (USEPA) Phase 2 emission standards. For Phase 2 certified engines, the Emissions Compliance Period referred to on the Emissions Compliance label indicates the number of operating hours for which the engine has been shown to meet Federal emission requirements.

For engines less than 225 cc displacement, Category C = 125 hours, B = 250 hours and A = 500 hours.

For engines of 225 cc or more, Category C = 250 hours, B = 500 hours and A = 1000 hours.

This is a generic representation of the emission label typically found on a certified engine.

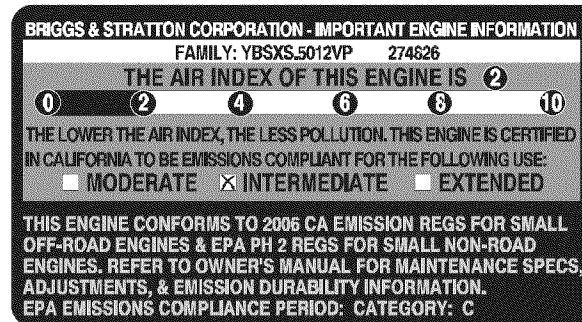

## REPAIR PROTECTION AGREEMENT

*Congratulations on making a smart purchase.* Your new Craftsman® product is designed and manufactured for years of dependable operation. But like all products, it may require repair from time to time. That's when having a Repair Protection Agreement can save you money and aggravation.

### **Here's what the Repair Protection Agreement\* includes:**

- ☑ **Expert service** by our 10,000 professional repair specialists
- ☑ **Unlimited service and no charge** for parts and labor on all covered repairs
- ☑ **Product replacement** up to \$1500 if your covered product can't be fixed
- ☑ **Discount of 25%** from regular price of service and related installed parts not covered by the agreement; also, 25% off regular price of preventive maintenance check
- ☑ **Fast help by phone** – we call it Rapid Resolution – phone support from a Sears representative. Think of us as a “talking owner's manual.”

Once you purchase the Repair Protection Agreement, a simple phone call is all that it takes for you to schedule service. You can call anytime day or night, or schedule a service appointment online.

The Repair Protection Agreement is a risk-free purchase. If you cancel for any reason during the product warranty period, we will provide a full refund. Or, a prorated refund anytime after the product warranty period expires. Purchase your Repair Protection Agreement today!

**Some limitations and exclusions apply. For prices and additional information in the U.S.A. call 1-800-827-6655.**

**\*Coverage in Canada varies on some items. For full details call Sears Canada at 1-800-361-6665.**

### **Sears Installation Service**

*For Sears professional installation* of home appliances, garage door openers, water heaters, and other major home items, in the U.S.A. or Canada call **1-800-4-MY-HOME®**.

# Get it fixed, at your home or ours!

## Your Home

For troubleshooting, product manuals and expert advice:



[www.managemylife.com](http://www.managemylife.com)

---

For repair – **in your home** – of **all** major brand appliances, lawn and garden equipment, or heating and cooling systems, **no matter who made it, no matter who sold it!**

For the replacement parts, accessories and owner's manuals that you need to do-it-yourself.

For Sears professional installation of home appliances and items like garage door openers and water heaters.

**1-800-4-MY-HOME<sup>®</sup>** (1-800-469-4663)

Call anytime, day or night (U.S.A. and Canada)

[www.sears.com](http://www.sears.com)      [www.sears.ca](http://www.sears.ca)

---

## Our Home

For repair of carry-in items like vacuums, lawn equipment, and electronics, call anytime for the location of your nearest

**Sears Parts & Repair Service Center**

**1-800-488-1222** (U.S.A.)

[www.sears.com](http://www.sears.com)

**1-800-469-4663** (Canada)

[www.sears.ca](http://www.sears.ca)

---

To purchase a protection agreement on a product serviced by Sears:

**1-800-827-6655** (U.S.A.)

**1-800-361-6665** (Canada)

---

Para pedir servicio de reparación a domicilio, y para ordenar piezas:

**1-888-SU-HOGAR<sup>®</sup>**

(1-888-784-6427)

[www.sears.com](http://www.sears.com)

Au Canada pour service en français:

**1-800-LE-FOYER<sup>MC</sup>**

(1-800-533-6937)

[www.sears.ca](http://www.sears.ca)

sears

® Registered Trademark / <sup>TM</sup> Trademark of KCD IP, LLC in the United States, or Sears Brands, LLC in other countries

® Marca Registrada / <sup>TM</sup> Marca de Fábrica de KCD IP, LLC en Estados Unidos, o Sears Brands, LLC in otros países

<sup>MC</sup> Marque de commerce / <sup>MD</sup> Marque déposée de Sears Brands, LLC