

EDGE STAR[®]

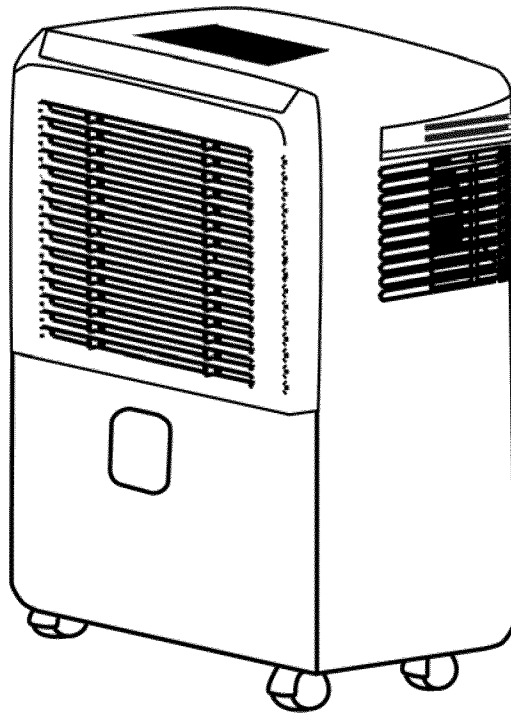

Dehumidifier



Model: DEP501EW

Owner's Manual

For more information on other great EdgeStar products on the web, go to <http://www.edgestar.com>

Important Safety Information

Improper handling can cause serious damage to the EdgeStar dehumidifier and/or to the user. This dehumidifier is designed for domestic indoor use only. Do not use the unit for industrial or commercial use. Any other use may invalidate the warranty. Please review the ratings label located on the rear panel of the unit for electrical and other technical data related to this unit. The unit must be used in a properly grounded wall outlet. Please read and follow the safety information listed below.



Electrical Safety

- This dehumidifier is designed for indoor use only. Do not use the unit near bath tubs, swimming pools or other bodies of water.
- Do not wet the housing or control panel.
- Do not exceed the power outlet ratings.
- Do not pull the unit by the cord.
- Always turn the unit off and unplug it from the outlet when cleaning.
- Unplug the unit if it is not going to be used for an extended time period.
- Do not operate the unit with a power plug missing the ground plug, a damaged cord or a loose socket.
- Be sure the dehumidifier is properly grounded.
- Never plug or unplug the unit with wet hands.
- Do not bypass, cut or remove the grounding plug.
- Do not use extension cords or power strips with this unit. You may need to contact your electrician if it is necessary to use a longer cord or do not have a grounded outlet. Do not modify the power cord's length or share the outlet with other appliances. It is recommended the unit be connected on its own circuit.
- Do not start or stop the unit by switching the circuit's power on and off.
- If the power cord is damaged, it must be replaced by the manufacturer or a qualified technician.
- Never open the unit while it is plugged in.
- Immediately unplug the unit if it makes strange sounds, emits smells or smoke comes out of it, and contact customer service.



General Safety

- This unit is not intended to be used by children.
- Children should be supervised to ensure that they do not play with this product.
- Do not allow children to play with the controls or drop any objects into the air outlets or vents.
- Care should be taken when using the unit in a room with infants, elderly persons, and children.
- Do not place flower vases, containers, or any objects on top of the unit.
- Do not allow anyone to sit on the unit.
- Do not climb on or use the unit as a step.
- Do not cover the air intake or exhaust vents with towels, clothes or materials that prevent air flow.
- When using in closets or confined spaces, be sure to keep doors open to allow proper ventilation.
- Do not use this appliance near flammable gas or combustibles, such as gasoline, benzene, thinner, etc.
- Do not use in areas where chemicals are handled.
- Do not place the unit near a heat source as doing so may cause the plastic parts to melt.
- Only use in an upright position on a flat, level surface and provide at least 10 inches of clearance from any walls or objects.
- Route the power cord carefully to avoid creating a tripping hazard.
- When using in closets or confined spaces, be sure to keep doors open to allow proper ventilation.
- Clean the filters every two weeks or as needed.



The water produced by the dehumidifier is not potable or suitable for drinking. Do not drink or use condensate or water drained from the unit as it contains contaminants and could make you sick.

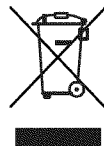

Electrical products should not be disposed of with household waste. Please contact your local recycling center for more information on how to recycle electronic waste.

Table of Contents

IMPORTANT SAFETY INFORMATION	1
INTRODUCTION	1
PARTS IDENTIFICATION	2
BACK VIEW	2
FRONT VIEW	2
INSTALLATION INSTRUCTIONS	3
CONTROL PANEL OVERVIEW	4
OPERATING THE CONTROL PANEL	5
POWER	5
<i>Auto-Restart:</i>	5
<i>Auto-Shut Off:</i>	5
CONTINUOUS MODE	5
FAN SPEEDS	5
SETTING THE HUMIDITY LEVEL	5
LCD DISPLAY	6
<i>Error Codes</i>	6
WATER FULL LIGHT	6
ADDITIONAL NOTES ABOUT THE DEHUMIDIFIER'S BEHAVIOR:	6
DRAINING THE UNIT	7
MANUAL DRAIN	7
CONTINUOUS DRAIN	7
MAINTENANCE	8
CLEANING THE UNIT	8
CLEANING THE PRE-FILTER	8
CLEANING THE WATER BUCKET	8
PREPARATION FOR STORAGE	9
ENERGY SAVING GUIDE	9
TROUBLESHOOTING	9
SPECIFICATIONS	12

Introduction

Thank you for purchasing this EdgeStar portable dehumidifier. We are glad you chose us. We believe that your purchase of this product opens a relationship between you and EdgeStar. We will provide the customer support needed to nurture that relationship.

This manual contains important information regarding the proper installation, use and maintenance of your portable dehumidifier. Following this manual will ensure that your product will work at its peak performance and efficiency.

Your dehumidifier is designed to remove moisture in the air by condensation removal and collecting the water in a removable bucket, or draining into a drain hose that can be routed to a drain hole on the floor or condensate pump.

Please save the original product packaging in case you need to safely transport your portable dehumidifier.

For Your Records:

Please write down the model number and serial number below for future reference. Both numbers are located on the ratings label on the back of your unit and are needed to obtain warranty service. You may also want to staple your receipt to this manual as it is the proof of your purchase, and is also needed for service under your warranty.

Model Number: _____

Serial Number: _____

Date of Purchase: _____

To better serve you, please do the following before contacting customer service:

- If you received a damaged product, immediately contact the dealer that sold you the product.
- Read and follow this instruction manual carefully to help you install, use and maintain your portable dehumidifier.
- Read the troubleshooting section of this manual as it will help you diagnose and solve common issues.
- Register your product at <http://www.edgestar.com> and download product guides, owner's manuals, and access additional troubleshooting resources.
- If you need warranty service, our friendly customer service representatives are available via email at service@edgestar.com or by telephone at **1 (866) 319-5473**.

Parts Identification

Front View

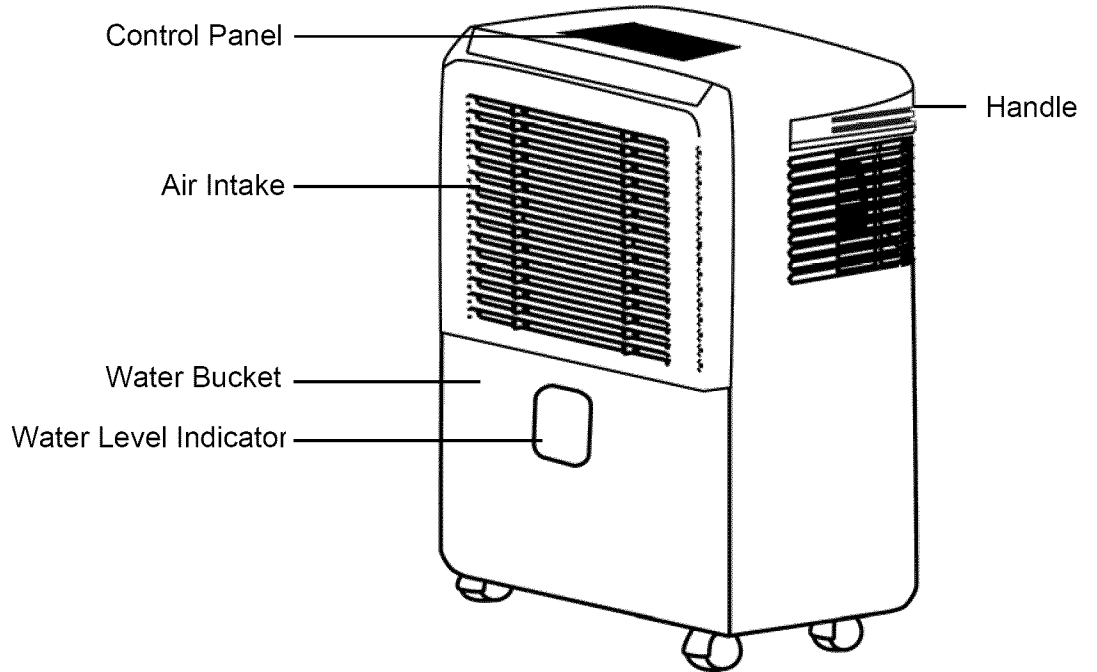

Back View

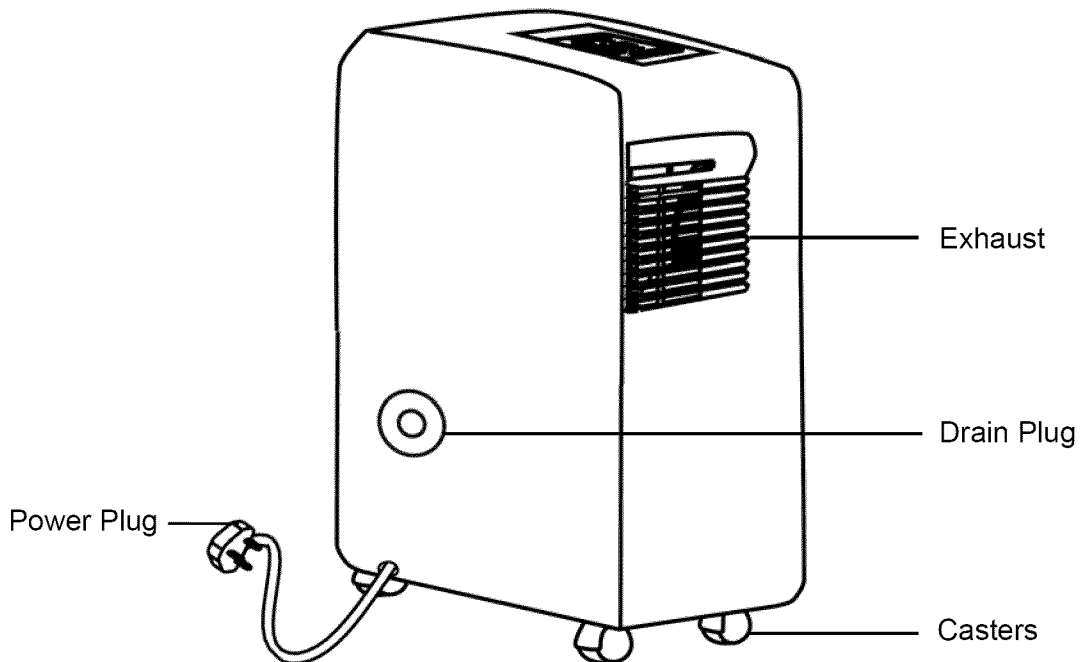

Installation Instructions

Your dehumidifier will remove moisture from the air and collect the excess water in a bucket. You can use the EdgeStar dehumidifier to create a comfortable environment and prevent damage caused by moisture to books or valuables in areas such as basements or home libraries. Follow the instructions below to unpack and set up your unit.

Note:

- Dehumidifiers working in a basement will have little or no effect on adjacent enclosed rooms such as closets, unless there is enough circulation of air in and out of the enclosed area.
- The unit is designed to work in environments with temperatures between 41°F and 95°F

1) Carefully unpack the dehumidifier from its box and packaging material, and remove the adhesive tape holding the water bucket and filter in place. You may want to save the box for storing and transporting the unit. Let the unit sit upright for at least 24 hours before powering it on to allow the compressor's fluids to settle.

2) Place the dehumidifier on a level floor or surface that is strong enough to support the unit with a full bucket of water in a room where the ambient temperature will not drop below 41°F, and away from any heat sources such as direct sunlight, heaters, radiators, dryers, etc.

Allow at least 10 inches of space all around the unit and at least 20 inches of space above the unit.

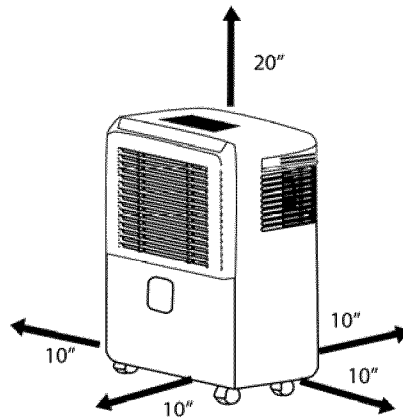

If you have multiple power outlets in the room, choose one that is near the dehumidifier and that will be able to provide adequate power to the unit. See the power requirements listed on the product label printed on the side, or on the back of your dehumidifier.

3) Close all windows and doors. To be most effective, use the dehumidifier in a contained room. For example, use it in a room with four walls and a ceiling, instead of a partitioned studio, or warehouse.

4) To activate the unit and ensure the warning switches are engaged, remove the water bucket and reinstall it; otherwise, the unit may not work properly.

5) Plug the unit in to a grounded outlet. (Read the Safety Information section.)

6) When first using the unit, press the Power button on the top of the unit and run it in continuous mode for 24 hours.

Caution:

The unit is designed to be used indoors and freestanding, and not be used outdoors, or be built-in to a cabinet or used under a counter.

Control Panel Overview

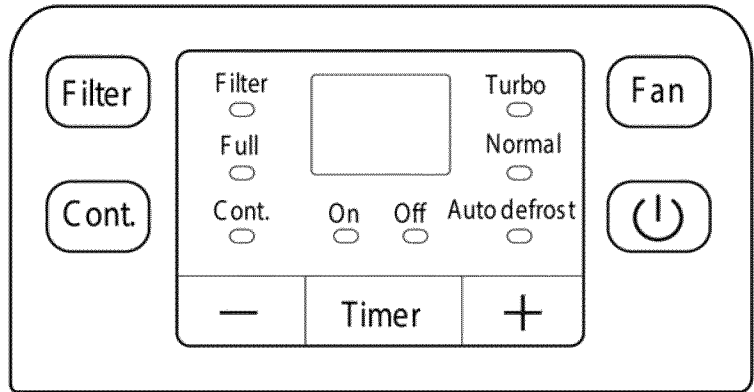

Button	Function
	The check filter feature is a reminder to clean the air filter for a more efficient operation. The Filter light will illuminate after 250 hours of operation. To reset after cleaning the filter, press the Filter button and the indicator light will shut off.
	Sets the unit to run continuously until the water bucket is full. You will not be able to use the increase/decrease humidity buttons.
	Sets the fan speed from normal to turbo for your desired level of moisture removal.
	Powers the unit on or off.
	Increases the desired relative humidity setting for damper air.
	Decreases the desired relative humidity setting for drier air.
	Press to initiate the auto start and auto stop feature in conjunction with the increase and decrease buttons.

Note: The unit is not a humidifier; using the increase humidity button will not add moisture to the air.

Indicator Light	Function
Filter	Lights up to indicate the filter needs to be cleaned.
Full	The water full light will light up red if the unit has filled the water bucket.
Cont.	Lights up when the unit is set to run continuously until the water bucket is full.
On/Off	Lights up to indicate if the unit is in on or off position.
Turbo	Lights up to indicate the fan is on the high setting.
Normal	Lights up to indicate the fan is on the low setting.
Auto-Defrost	Lights up to indicate the auto defrost operation is on
LCD Display	Displays the level of humidity as well as error codes.

Operating the Control Panel

Power

Use the "Power" button to turn the portable dehumidifier on and off. By default when you first use the power button, the unit will begin to operate in normal fan speed mode.

Note: If the unit was powered off, wait at least 3 minutes before powering it back on.

Auto-Restart: If power to the unit is interrupted, the dehumidifier will restart itself in with the last used mode/settings once the power is restored. The compressor will restart after 3 minutes.

Auto-Shut Off: The unit will shut off when the set humidity has been reached, or when the water bucket is full, has been removed, or is not in its proper position.

Continuous Mode

Continuous mode dehumidifies the air until the water bucket is full. Use the continuous mode for maximum dehumidification. You will not be able to use the set humidity buttons.

To operate the unit in continuous mode:

- 1) Make sure the power cord is plugged into a power outlet.
- 2) Press the "Power" button.
- 3) Press the "Cont." button. The LED indicator next to "Cont." will light up.
- 4) Select the fan speed by using the Normal or High button.

Fan Speeds

The dehumidifier has two fan speeds. Use the turbo fan speed for maximum moisture removal. Use the normal fan speed for quieter operation.

Select the fan speed by pressing the "Fan" button until desired mode is illuminated

Setting the Humidity Level

Note: Relative Humidity (RH) is the ratio of the actual water content of the air at a given temperature to the potential water content at that same temperature.

The desired humidity level can be set within a range of 35% Relative Humidity (RH) to 80% RH in 5% increments.

To set the desired humidity level percentage:

- 1) Make sure the power cord is plugged into a power outlet.
- 2) Press the Power button. Make sure the "Cont." light is turned off.
- 3) Press the "Increase" and "Decrease" buttons to set the desired humidity level. After a few seconds, the LCD display will revert to the actual room humidity level with $\pm 5\%$ accuracy. For drier air use the "Decrease" button.

Operating the Control Panel *continued*

LCD Display

The LCD Display will show the room's relative humidity percentage by default. Pressing the Increase and Decrease buttons will show the set humidity for a few seconds, and then revert to the room's relative humidity.

Error Codes

In addition to showing the humidity, the display may show the following error codes:

AS – Humidity sensor error

Power the unit off, and then unplug the unit for 15 minutes. Plug in and power on. If the issue persists, please contact customer service.

ES – Temperature sensor error

Power the unit off, and then unplug the unit for 15 minutes. Plug in and power on. If the issue persists, please contact customer service.

EC – Unit malfunction

Please make sure whether the ambient temperature is suitable for the stated temperature in the manual or not. If not, please operate the unit under the stated temperature. If the environment temperature is suitable for the stated temperature, please contact customer service.

P2 – Bucket is full

Empty the water bucket and reinstall it.

Water Full Light

The Water Full Light will illuminate when the bucket is ready to be emptied. The light also turns on when the bucket is not installed or installed incorrectly. Once the water is drained, and the bucket is properly installed, the unit will operate normally.

Additional notes about the dehumidifier's behavior:

- Once the unit reaches the desired set humidity, the power button will remain lit while the compressor and fan shuts off. You will not be able to change the fan speed.
- If the power to the unit was interrupted while the compressor was running, the unit may take a few minutes to start the fan and compressor.
- If the room's relative humidity is lower than the set humidity, the unit will not start the fan and compressor unless you set the unit to run in Continuous mode.

Draining the Unit

Manual Drain

The dehumidifier can be drained manually using the water bucket. When the bucket is full, the unit will automatically stop running, and the water full light will turn on.

Follow the steps to remove the bucket and dump the water.



Warning: The water produced by the dehumidifier is not potable or suitable for drinking.

Do not drink the water drained from the unit as it contains contaminants and could make you sick.

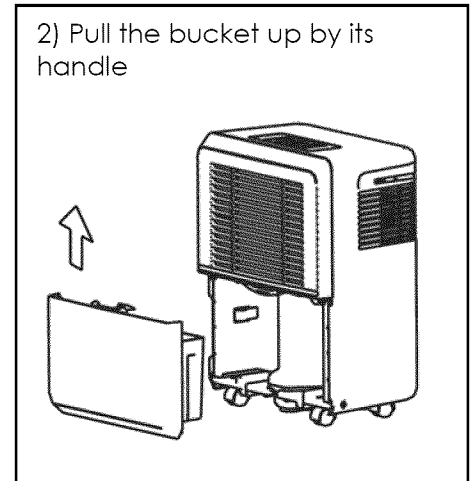
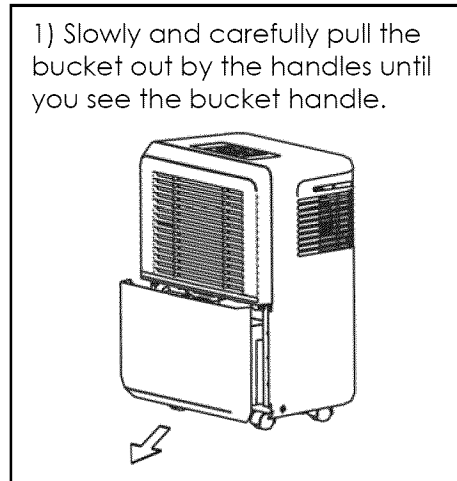

3) Pour the water out. Do not place the bucket on the floor as its bottom is uneven and will fall down.

4) Reinstall the bucket.

Continuous Drain

The dehumidifier can be drained continuously to a floor drain.

1) Remove the water bucket from the unit, and you will find a hose connector. You can use a 12 mm hose to attach to the connector.

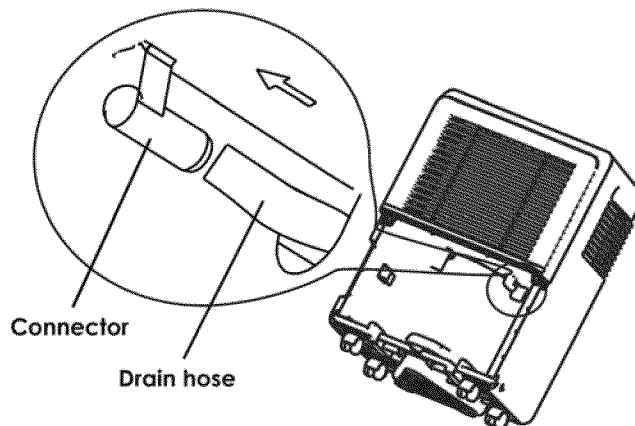

2) Remove the rubber plug from the back of the unit's drain hose outlet, and push the drain hose through.

3) Securely attach the drain hose to the connector. Lead the other end of the hose to a floor drain or other suitable drainage port.

4) You must reinstall the water bucket.

Maintenance

Clean the dehumidifier and filters regularly to maintain performance and efficiency, and prolong the unit's life. Be sure to always unplug the dehumidifier from the power outlet before cleaning.

Cleaning the unit

Use a soft dry cloth to wipe the body clean. If necessary, use lukewarm water to dampen a cloth to clean the unit. Use a soft bristle brush and vacuum cleaner to clean between the air intake and exhaust vents.

Never use abrasive chemicals, volatile substances, gasoline, detergents, chemically treated cloths, or other cleaning solvents that may damage the cabinet exterior.

Never spray water directly on the unit.

Cleaning the pre-filter

Clean the pre-filter periodically to prolong the unit's life, and keep the unit running efficiently. Lint, dust, and dirt can clog the unit and reduce its performance and effectiveness. If the unit is used in a dusty environment you may need to clean it on a weekly basis.

To clean the pre-filter, follow the steps below:

1) Power off the unit and remove the pre-filter.

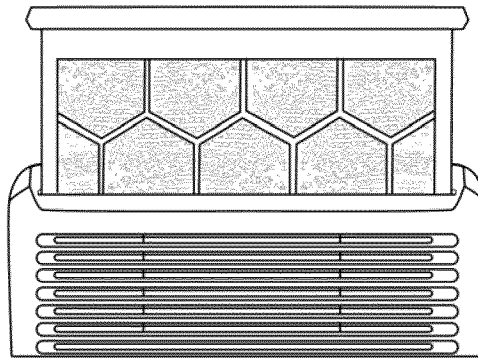

NOTE: Do not put the filter in a dishwasher.

2) Use a vacuum cleaner or tap the filter lightly to remove loose dust and dirt, then rinse thoroughly under lukewarm running water (below 104°F). You may use a mild soap and water solution if needed. Allow the pre-filter to air dry in a cool and shaded place. Dry thoroughly before reinstalling.

3) Reinsert the pre-filter.

Warning: Never operate the unit without the air filter.

Cleaning the water bucket

Wash the water bucket frequently to prevent the growth of bacteria, mildew and mold.

To clean the water bucket, follow the steps below:

1) Remove the water bucket from the unit.

2) Wash the bucket with clean water and a mild detergent. Rinse the bucket thoroughly.

3) Install the water bucket.

NOTE: Do not put the water bucket in a dishwasher.

Maintenance continued

Preparation for Storage

If you are not going to be using the unit for an extended period of time, follow the instructions below before storing your unit:

- 1) Turn off the unit and wait 24 hours before emptying the water tank.
 - 2) Drain all the water from the water tank.
 - 3) Clean the air filter, water tank and unit.
 - 4) Unplug and carefully wind the power cord.
 - 5) Cover the unit with a plastic bag.
 - 6) Store the unit in an upright position in a dry, well-ventilated place.
-

Energy Saving Guide

Read and follow the guide below to get the best performance and efficiency from your portable dehumidifier:

- Do not cover the air outlet (exhaust) while in use.
 - Do not place the unit in front of curtains or drapes- to ensure they do not obstruct the air intake.
 - Keep curtains, blinds or drapes closed during the sunniest part of the day.
 - Close all windows and doors.
 - Indoor relative humidity should ideally be kept between 35 and 60 percent depending on the ambient temperature.
 - Make sure the unit is on a level surface.
 - To prolong the compressor's life, please wait at least 3 minutes before turning the unit back on after shutting it off.
 - Inspect and keep the pre-filters clean by cleaning regularly.
 - Perform routine maintenance.
-

Troubleshooting

Follow the troubleshooting chart to resolve common issues.

Issue	Possible Cause	Solution
My dehumidifier does not dry the air	Insufficient time to dry	Run the unit for a longer period of time.
	Air intake or Exhaust vents are blocked	Make sure there are no towels, curtains, or furniture blocking the front and back of the unit.
	Humidity control may not be set low enough	Lower the humidity control. Run the unit in continuous mode.
	Opened windows or doors	Close all windows and doors.
	Room temperature is too low (below 41°F)	Increase the room temperature.
	There is a kerosene heater or something giving off water vapor in the room	Remove any device producing water vapor.
Frost appears on the coils	This is normal behavior	The dehumidifier has an auto-defrost feature.
My dehumidifier is not functioning at all	Unit is not receiving power	Make sure the unit is plugged in.
	Insufficient power	Move the unit to another outlet. Check your circuit breaker. (Refer to the rating label on the back of the unit to determine the Amperage draw).
	Water bucket is full	Drain the unit and restart.
	Water bucket is not in proper position	Remove bucket and reinsert.
	Control panel is disconnected	If no indicator lights turn on, contact customer service.
My dehumidifier is making a loud noise	The unit is not level	Make sure the unit is on a level surface.
	A foreign object has jammed the fan	Shut off the unit, and remove the object from the fan.
	The floor below the unit is uneven	Move the unit to a level surface.
	Air filter is clogged	Clean the air filter.
My dehumidifier is making a continuous metallic knocking or pinging sound	Unit may have been shipped on its side	Shut off the unit. Let the unit sit on a level surface for at least 24 hours and restart.
	Damaged compressor	Contact customer service.

Troubleshooting continued...

My dehumidifier is leaking	A drain hose has been attached and is loose	Secure the drain hose. Route your drain hose to a drain hole or condensate pump.
	Cracked water bucket	Contact customer service.
My dehumidifier runs for a little while and then it trips the power cord or the circuit breaker	The dehumidifier may be plugged into an outlet that can not supply the correct amount of current	Contact an electrician if the unit works in a different room or circuit.
The control panel lights blink randomly	Unit may have a faulty control panel	Restart the unit, and if issue persists, contact customer service.
Unit has an AS error	Humidity sensor error	Restart the unit, and if issue persists, contact customer service.
Unit has an ES error	Temperature sensor error	Restart the unit, and if issue persists, contact customer service.
Unit has a EC error	Unit malfunction	Make sure the ambient temperature is suitable for the unit (41°F – 95°F). If not please operate the unit under the stated temperature. If the ambient temperature is suitable, please contact customer service.
Unit has a P2 error	Bucket is full Bucket is not correctly installed	Empty the bucket and reinstall. Remove the bucket and reinstall.

Specifications

Description of product	Portable Dehumidifier
Model	DEP501EW
Voltage/Frequency	AC 115V~60Hz
Power Consumption	520W
Operating Current	4.7A
Water Bucket Capacity	7.5 Liters / 1.98 Gallons
Dehumidifying Capacity @ 80F RH60%	50 Pints/Day
Refrigerant	R410A
Dimensions W x D x H	15 3/8" x 10 9/16" x 23 1/8"
Weight	36 lbs.

EdgeStar Limited Warranty

One (1) Year Parts & Ninety (90) Days Labor

This product is warranted by EdgeStar to be free from defective workmanship and materials, subject to any conditions set forth as follows:

WHAT IS COVERED:

LABOR: For a period of NINETY (90) DAYS from the date of original purchase, labor will be performed free of charge at an authorized EdgeStar repair facility. At its option, EdgeStar will repair the product with new or remanufactured parts, or exchange the defective product with a new, refurbished, or remanufactured product. If a product is replaced, it will carry the remaining warranty of the original product. After the ninety (90) day period, EdgeStar will no longer be responsible for labor charges incurred. All defective products and parts covered by this warranty will be repaired or replaced on a mail-in basis to an EdgeStar authorized repair facility.

PARTS: For a period of ONE (1) YEAR from the date of original purchase, EdgeStar will supply new, rebuilt, or refurbished parts free of charge. EdgeStar may request a defective part be returned in exchange for the replacement part. All replacement parts or products will be new, remanufactured, or refurbished. All products and parts replaced by EdgeStar under warranty service become the property of EdgeStar.

This warranty applies to the original purchaser only, and only covers defects in workmanship experienced during operation of the product under normal service, maintenance, and usage conditions. This warranty applies to the purchase and use of this product in residential settings within the United States of America.

WHAT IS NOT COVERED:

The following limitations apply to the coverage of this warranty. This warranty does not cover:

- Labor charges for installation, setup or training to use the product.
- Shipping damage, and any damage caused by improper packaging for shipment to an authorized service center, and any damaged caused by improper voltage or any other misuse, including abnormal service, handling, or usage.
- Cosmetic damage such as scratches and dents.
- Normal wear and tear on parts or replacement of parts designed to be replaced, e.g. filters, cartridges, batteries.
- Service trips to deliver, pick-up, or repair, install the product, or to instruct in proper usage of the product.
- Damages or operating problems resulting from misuse, abuse, operation outside environmental specifications, uses contrary to instructions provided in the owner's manual, accidents, acts of God, vermin, fire, flood, improper installation, unauthorized service, maintenance negligence, unauthorized installation or modification, or commercial use.
- Labor charges incurred 91 days or more after the date of original purchase.
- The use of EdgeStar products in commercial settings.
- Optional accessories, attachments, and appearance items.
- Products that have been modified to perform outside of specifications without the prior written permission of EdgeStar.
- Products lost in shipment, or theft.
- Products sold AS IS or from an unauthorized reseller.
- Products that have had their serial numbers removed or defaced. Products with serial numbers that have been invalidated.

OBTAINING WARRANTY SERVICE:

If you believe your product is defective, contact EdgeStar Customer Support for troubleshooting assistance and warranty service at 1-866-319-5473. Please have your serial number and proof of purchase available. Once an EdgeStar authorized representative has confirmed that your product is defective and eligible for warranty service, the product must be returned to an EdgeStar repair facility. The purchaser is solely responsible for prepaying all shipping related costs to and from the repair facility. EdgeStar is not responsible for damage resulting from shipper mishandling or improper packaging. Do not return a defective product to the place of purchase. Products received without a return authorization number will be refused.

THIS WARRANTY IS IN LIEU OF ANY OTHER WARRANTY, EXPRESS OR IMPLIED, INCLUDING WITHOUT LIMITATION, ANY WARRANTY OF MERCHANTABILITY OR FITNESS FOR A PARTICULAR PURPOSE. TO THE EXTENT ANY IMPLIED WARRANTY IS REQUIRED BY LAW, IT IS LIMITED IN DURATION TO THE EXPRESS WARRANTY PERIOD ABOVE. NEITHER THE MANUFACTURER NOR ITS DISTRIBUTORS SHALL BE LIABLE FOR ANY INCIDENTAL, CONSEQUENTIAL, INDIRECT, SPECIAL, OR PUNITIVE DAMAGES OF ANY NATURE, INCLUDING WITHOUT LIMITATION, LOST REVENUES OR PROFITS, OR ANY OTHER DAMAGE WHETHER BASED IN CONTRACT, TORT, OR OTHERWISE. SOME STATES DO NOT ALLOW THE EXCLUSION OF INCIDENTAL OR CONSEQUENTIAL DAMAGES, SO THE ABOVE EXCLUSION MAY NOT APPLY TO YOU. THIS WARRANTY GIVES YOU SPECIFIC LEGAL RIGHTS. YOU MAY HAVE OTHER RIGHTS THAT VARY FROM STATE TO STATE.

EDGESTAR

EdgeStar Products
500 N. Capital of TX Hwy, Bldg 5
Austin, TX 78746

Toll Free: 1-866-319-5473
Web: <http://www.edgestar.com>
E-mail: service@edgestar.com

Register your product, download owner's manuals, access additional troubleshooting resources, and obtain more information on other great EdgeStar & Koldfront products on the web at: <http://www.edgestar.com>

Product contents and specifications may change without notice.

Copyright © 2012 Living Direct, Inc. All rights reserved.