

Safety Instructions & Operator's Manual for

SNAPPER®

**21" VARIABLE SPEED
REAR DISCHARGE
WALK BEHIND
MOWERS**

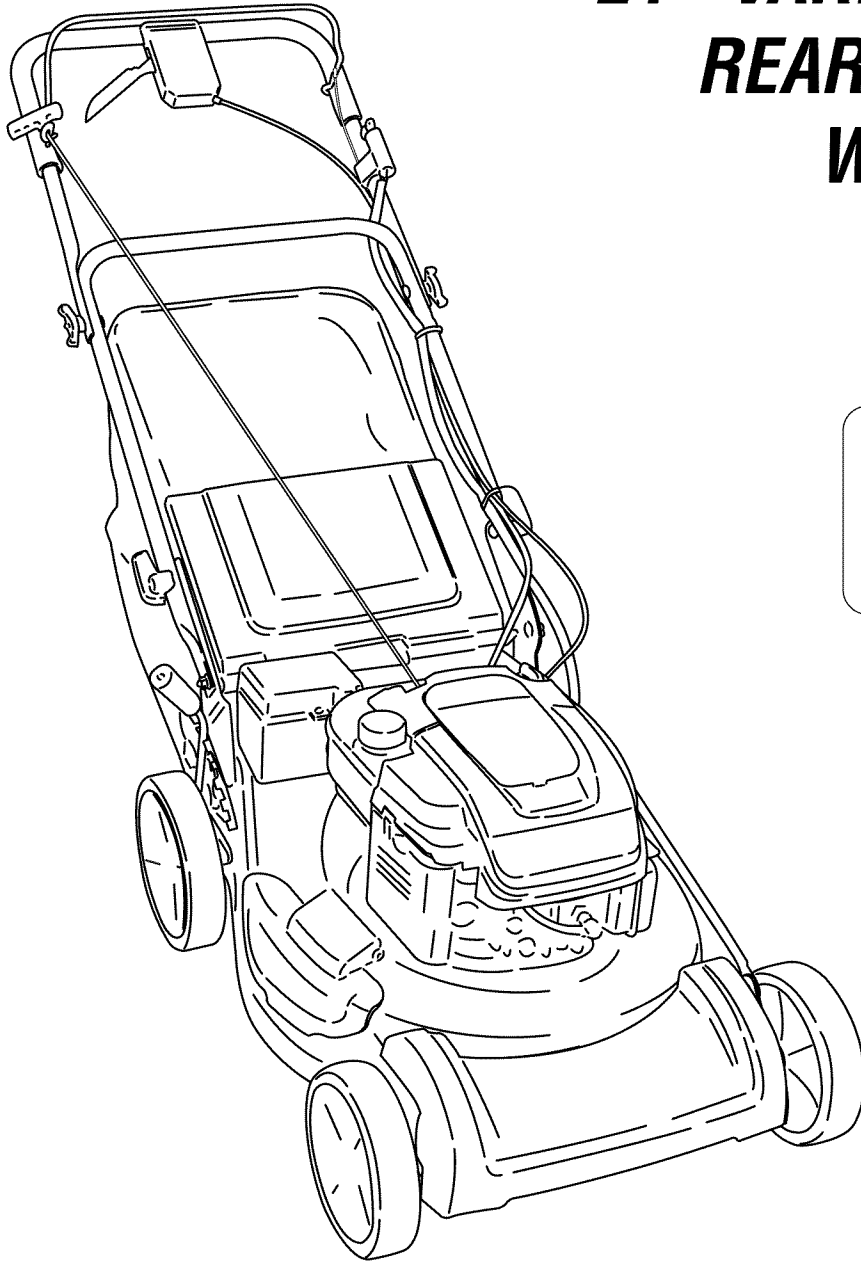

Models

**SPV21675FC (7800265)
SPV21675EFC (7800266)**

NOTE: Specifications are correct at time of printing and are subject to change without notice.

* Actual sustained engine power will likely be lower due to operating limitations and environmental factors. Please refer to 'Engine Power Rating Information' for further details.

Thank You for purchasing this quality-built Snapper mower. We're pleased that you placed your confidence in the Snapper brand. When operated and maintained according to the instructions in this manual, your Snapper mower will provide many years of dependable service.

This manual contains safety information to make you aware of the hazards and risks associated with the machine and how to avoid them. This machine is designed and intended only for finish cutting of established lawns and is not intended for any other purpose. It is important that you read and understand these instructions thoroughly before attempting to start or operate this equipment. Save these instructions for future reference.

PRODUCT REGISTRATION

IMPORTANT: KEEP THIS INFORMATION FOR YOUR PERSONAL RECORDS
(Complete the following information on your Snapper purchase)

Date of Purchase _____

Retailer _____

Retailer's Phone Number _____

Equipment

Model Number _____

Serial Number _____

Engine

Model _____ Type _____ Trim _____



It is very important that you register your purchase with Snapper to ensure warranty coverage. Please mail your product registration card to:

Snapper at P.O. Box 1379, McDonough, Georgia 30253.



You can contact us at our website (www.snapper.com), or if you would like to speak with a Customer Service Representative, call us at the Snapper Customer Relations Center at 1-800-317-7833. For faster service please have your Serial Number and Model Number available.

Table of Contents

Operator Safety	2
Important Operator Safety Instructions	2
Features and Controls	4
Operation	5
Pre-Start Checklist	5
Starting & Stopping Engine & Blade	5
Propelling Mower	6
Handle Height Adjustment	6
Cutting Height Adjustment	7
Recycling Operation	7
Installing the Discharge Deflector	8
Removing the Recycling Plug	8
Installing the Grass Bag	8
Maintenance	9
Change Engine Oil	9
Check Mower Blade	9
Check Engine Drive Belt	9
Service - Periodic	9
Engine	9
Air Filter	9
Engine Oil	9
Wheel Drive Components	10
Storage Procedure	10
Mower Blade Replacement	11
Blade Sharpening	11
Wheel Drive Control Adjustment	12
Belt Service	13
Engine Drive Belt Replacement	13
Battery Service	14
Rear Cover Removal & Installation	15
Service Schedule	16
Troubleshooting	17
Warranty	18
Slope Guide	19

 **WARNING** 

Battery posts, terminals and related accessories contain lead and lead compounds, chemicals known to the State of California to cause cancer and birth defects or other reproductive harm. Wash hands after handling.

 **WARNING** 

Engine exhaust, some of its constituents, and certain vehicle components contain or emit chemicals known to the State of California to cause cancer or other reproductive harm.



IMPORTANT OPERATOR SAFETY INSTRUCTIONS



WARNING: This powerful cutting machine is capable of amputating hands and feet and can throw objects that can cause injury and damage! Failure to comply with the following SAFETY instructions could result in serious injury or death to the operator or other persons. The owner of the machine must understand these instructions and must allow only persons who understand these instructions to operate machine. Each person operating the machine must be of sound mind and body and must not be under the influence of any substance, which might impair vision, dexterity or judgment. If you have any questions pertaining to your machine which your dealer cannot answer to your satisfaction, call or write the Customer Service Department at SNAPPER, McDonough, Georgia 30253. Phone: (1-800-317-7833).

PROTECTION FOR CHILDREN

Tragic accidents can occur if the operator is not alert to the presence of children. Children are often attracted to the machine and the mowing activity. Never assume that children will remain where you last saw them.

1. KEEP children out of the mowing area and under the watchful care of a responsible adult other than the operator.
2. DO NOT allow children in yard when machine is operated and turn machine OFF if anyone enters the area.
3. DO NOT allow pre-teenage children to operate machine.
4. ALLOW only responsible adults & teenagers with mature judgment under close adult supervision to operate machine.
5. DO NOT pull mower backwards unless absolutely necessary. LOOK and SEE behind and down for children, pets and hazards before and while backing.
6. USE EXTRA CARE when approaching blind corners, shrubs, trees, or other objects that may obscure vision.

SLOPE OPERATION

1. Slopes are a major factor related to slip and fall accidents, which can result in severe injury. All slopes require extra caution. If you feel uneasy on a slope, DO NOT mow it.
2. Mow across slopes, never up-and-down. Exercise extreme CAUTION when changing directions on slopes. DO NOT mow steep slopes or other areas where stability or traction is in doubt. Refer to the Slope Guide at the back of this manual.
3. Use extra care with grass catchers or other attachments; these affect the handling and the stability of the machine.

PREPARATION

1. Read, understand, and follow instructions and warnings in this manual and on the mower, engine and attachments. Know the controls and the proper use of the mower before starting.
2. Only mature, responsible persons shall operate the machine and only after proper instruction.
3. Data indicates that operators age 60 and above, are involved in a large percentage of mower-related injuries. These operators should evaluate their ability to operate the mower safely enough to protect themselves and others from serious injury.
4. Handle fuel with extra care. Fuels are flammable and vapors are explosive. Use only an approved fuel container. DO NOT remove fuel cap or add fuel with engine running.

PREPARATION

(Continued From Previous Column)

- Add fuel outdoors only with engine stopped and cool. Clean spilled fuel and oil from machine. DO NOT smoke.
5. Check the area to be mowed and remove all objects such as toys, wire, rocks, limbs and other objects that could cause injury if thrown by blade or interfere with mowing. Also note the location of holes, stumps, and other possible hazards.
 6. Keep people and pets out of the mowing area. Immediately, STOP Blade, Stop engine and Stop mower if anyone enters the area.
 7. Check shields, deflectors, switches, blade controls and other safety devices frequently for proper operation and location.
 8. Make sure all safety decals are clearly legible. Replace if damaged.
 9. Protect yourself when mowing and wear safety glasses, long pants and substantial footwear. DO NOT mow barefooted or with sandals.
 10. Know how to STOP blade and engine quickly in preparation for emergencies.
 11. Use extra care when loading or unloading the machine into a trailer or truck.
 12. Check grass catcher components frequently for signs of wear or deterioration and replace as needed to prevent injury from thrown objects going through weak or torn spots.

SAFE HANDLING OF GASOLINE

To avoid personal injury or property damage, use extreme care in handling gasoline. Gasoline is extremely flammable and the vapors are explosive.

1. Extinguish all cigarettes, cigars, pipes and other sources of ignition.
2. Use only an approved fuel container.
3. DO NOT remove fuel cap or add fuel with the engine running. Allow the engine to cool before refueling.
4. DO NOT refuel the machine indoors.
5. DO NOT store the machine or fuel container inside where there is an open flame, spark or pilot light such as on a water heater or other appliances.
6. DO NOT fill fuel containers inside a vehicle or on a truck or trailer bed with a plastic liner. Always place the containers on the ground away from the vehicle before filling.



IMPORTANT OPERATOR SAFETY INSTRUCTIONS (Continued)



SAFE HANDLING OF GASOLINE (Continued From Previous Page)

7. Remove gas-powered equipment from the vehicle or trailer and refuel it on the ground. If this is not possible, then refuel equipment using a portable container, rather than a gasoline dispenser nozzle.
8. DO NOT start gas powered equipment in enclosed vehicles or trailers.
9. Keep the nozzle in contact with the rim of the fuel tank or container opening at all times until fueling is complete. DO NOT use a nozzle lock-open device
10. If fuel is spilled on clothing, change clothing immediately.
11. DO NOT overfill a fuel tank. Replace fuel cap and tighten securely.

OPERATION

1. DO NOT put hands or feet near or under rotating parts. Keep clear of discharge area while engine is running.
2. STOP engine when crossing gravel drives, walks, or roads, and under any conditions where thrown objects might be a hazard.
3. Mow only in daylight or good artificial light.
4. DO NOT operate mower while under the influence of alcohol or drugs.
5. After striking a foreign object or if mower vibrates abnormally, STOP the engine, disconnect and secure spark plug wire. Inspect the mower for any damage and repair the damage before starting.
6. DO NOT mow near drop offs, ditches or embankments. Operator could lose footing or balance.
7. STAY ALERT for holes and other hidden hazards. Tall grass can hide obstacles. Keep away from ditches, washouts, culverts, fences and protruding objects.
8. DO NOT mow on wet grass. Always be sure of your footing. Keep a firm hold on the handle and walk, never run. Slipping could cause injury.
9. ALWAYS stay behind handle when engine (motor) is running.
10. DO NOT leave the machine with the engine running. STOP BLADE and STOP ENGINE before leaving the operators position for any reason.
11. Before cleaning, repairing or inspecting make certain engine, blade and all moving parts have STOPPED. Disconnect and secure spark plug wire away from plug to prevent accidental starting.
12. STOP engine and wait until the blade comes to complete STOP before removing grass bag and/or clearing grass.
13. DO NOT operate mower without the entire grass catcher, or guards in place discharge guard, rear guard or other safety devices in place and working. DO NOT point discharge at people, passing cars, windows or doors.

OPERATION (Continued From Previous Column)

14. DO NOT discharge material against a wall or obstruction. Material may ricochet back towards the operator.
15. Slow down before turning.
16. Watch out for traffic when near or crossing roadways.
17. DO NOT operate engine in enclosed areas. Engine exhaust gases contain carbon monoxide, a deadly poison.
18. Only use accessories approved by the manufacturer. See manufacturer's instructions for proper operation and installation of accessories.

MAINTENANCE AND STORAGE

1. DO NOT store mower or fuel container inside where fumes may reach an open flame, spark or pilot light such as in a water heater, furnace, clothes dryer or other gas appliance. Allow engine to cool before storing machine in an enclosure. Store fuel container out of reach of children in a well ventilated, unoccupied building.
2. Keep mower and engine free of grass, leaves or excess grease to reduce fire hazard and engine overheating.
3. When draining fuel tank, drain fuel into an approved container outdoors and away from open flame.
4. Keep all bolts, especially blade bolts, nuts and screws properly tight. Check that all cotter pins are in proper position.
5. Always provide adequate ventilation when running engine. Engine exhaust gases contain carbon monoxide, a deadly poison.
6. Service engine and make adjustments only when engine is stopped. Removed spark plug wire from spark plug and secure wire away from spark plug to prevent accidental starting.
7. DO NOT change engine governor speed settings or overspeed engine.
8. Check grass bag assembly frequently for wear or deterioration to avoid thrown objects and exposure to moving parts. Replace with new bag if loose seams or tears are evident. Replace slider or bag adapter if broken or cracked.
9. Mower blades are sharp and can cut. Wrap the blades or wear heavy leather gloves and use CAUTION when handling them.
10. DO NOT test for spark by grounding spark plug next to spark plug hole; spark plug could ignite gas exiting engine.
11. Have machine serviced by an authorized SNAPPER dealer at least once a year and have the dealer install any new safety devices.
12. Use only genuine SNAPPER replacement parts to assure that original standards are maintained.

IMPORTANT

The figures and illustrations in this manual are provided for reference only and may differ from your specific model. Contact your Snapper dealer if you have questions.

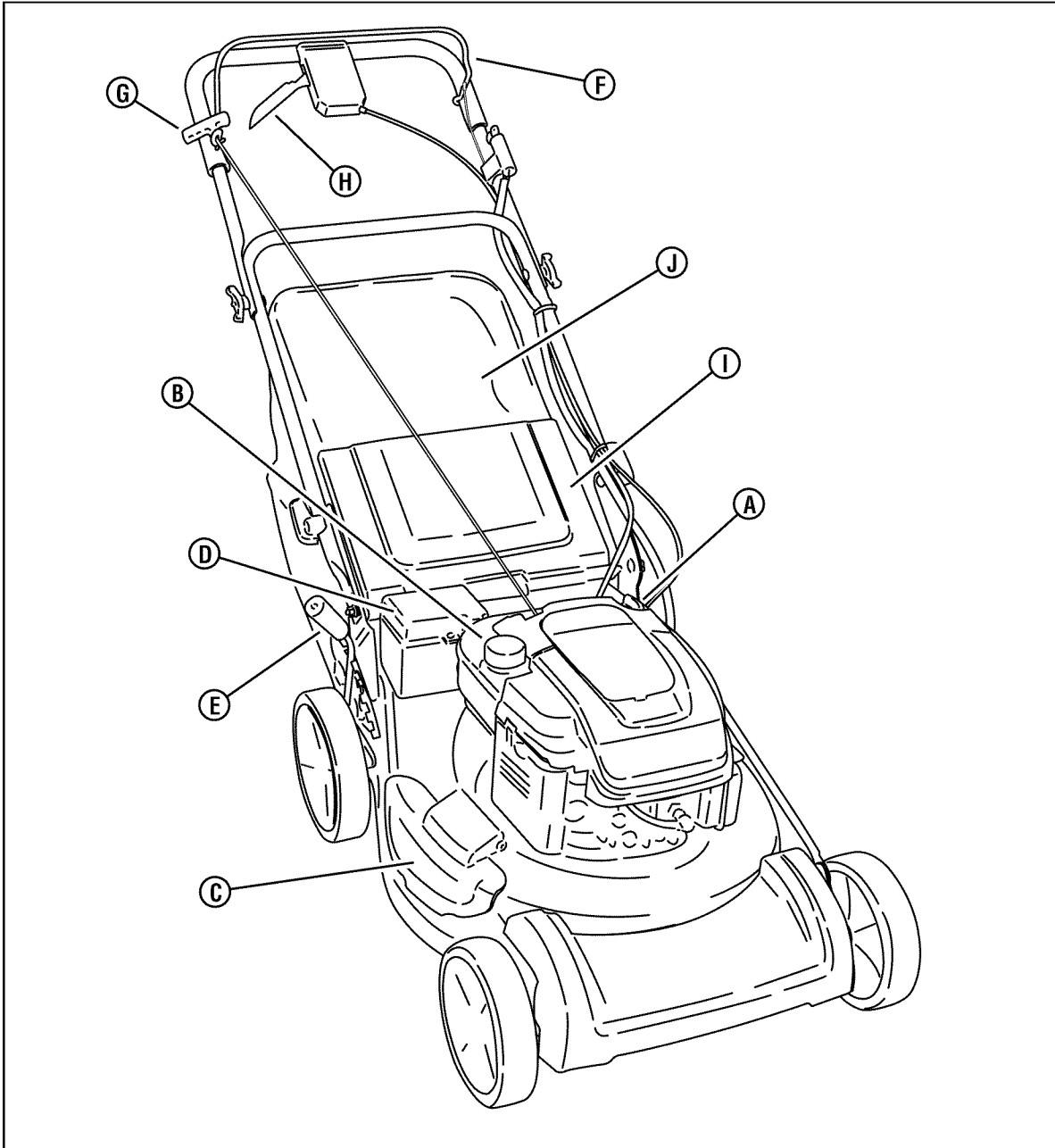

Features and Controls

- | | | | |
|----|---------------------------|----|---------------------|
| A. | Oil Fill Cap and Dipstick | F. | Blade Control |
| B. | Fuel Filler Cap | G. | Rope Start Handle |
| C. | Recycling Cover | H. | Drive Wheel Control |
| D. | Battery Box | I. | Rear Discharge Door |
| E. | Height Adjustment Lever | J. | Grass Bag |

Pre-Start Check List

Make the following checks and perform the service required before each start-up.

1. Check the guards, deflectors, grass bag, and covers to make sure all are in place and securely tightened.
2. Check the blade control (**A, Figure 1**) and wheel drive control (**B**) to insure they work freely.

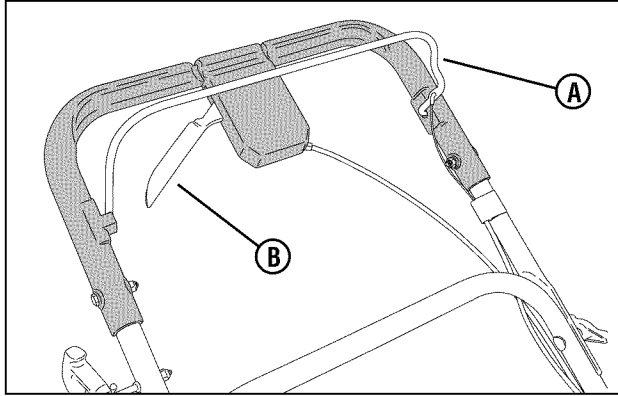

Figure 1: Mower controls

3. Check the cutting height. Adjust to the desired height. Refer to the Section 'Cutting Height Adjustment'.
4. Check the engine oil and add oil as needed to bring the level up to the full mark (**A, Figure 2**). Refer to the Engine Owner's Manual for oil specifications.

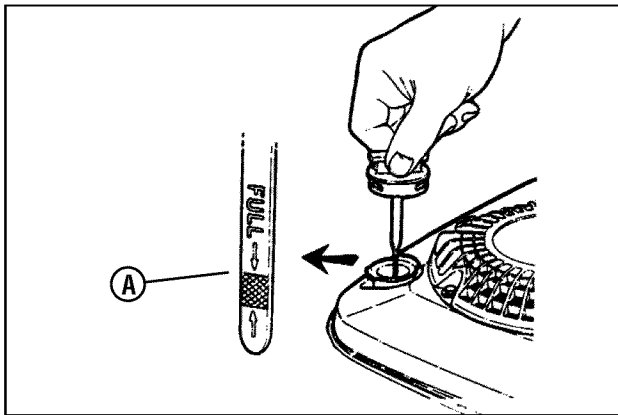

Figure 2: Checking engine oil

5. Add fuel to the tank after pushing the mower outside where fumes can safely dissipate. Fill the tank to 1-1/2 inches below the top of the filler neck (to allow for fuel expansion). Make sure the cap is tightened after fueling. Refer to the Engine Owners Manual for fuel specifications.
6. Clean the exterior surfaces of the cutting deck and engine of any accumulation of spilled fuel, dirt, grass, oil, etc. Keep the engine air intake screen and cooling fins clear at all times.
7. Perform battery service. Refer to the Section 'Battery Service'.

Starting and Operation

Engine and Blade

1. Pull the blade control (**A, Figure 3**) against the handle.
2. Start the mower:
 - Manual Start Models:** Pull the rope start handle (**B**) to crank the engine.
 - Electric Start Models:** Insert the key (**C**) into the ignition switch (**D**), located on the right side of the handle above the rope guide. Turn the key to crank the engine.
3. After the engine starts, allow a brief warm-up until the engine runs smooth before beginning mower operation.

NOTE: To stop the engine (and blade), release the blade control.

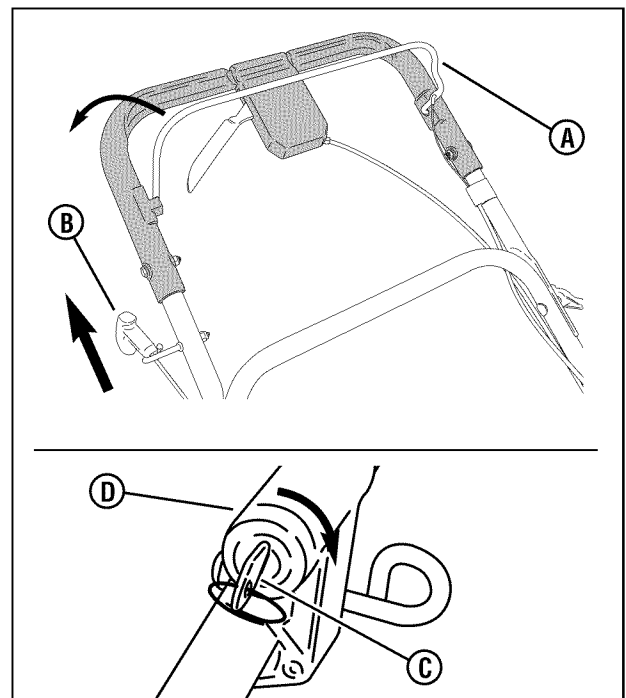

Figure 3: Starting the mower

Starting and Operation (Continued)

Propelling the Mower

1. Start the engine. Refer to the Section entitled “Starting and Operation – Engine and Blade”.
2. Begin squeezing the wheel drive control (**A, Figure 4**) back toward the handle to engage the wheel drive and propel the mower forward. Forward speed can be increased by squeezing the wheel drive control further back toward the handle.

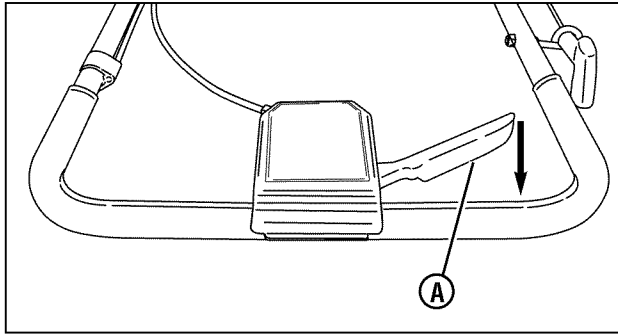

Figure 4: Wheel drive control
(Components removed for clarity)

Handle Height Adjustment

The height of the mower handle can be adjusted as follows:

1. Turn the two locking cams (**A, Figure 5**) a quarter-turn to unlock the handle assembly (**B**).
2. Align the handle assembly with one of the three handle height adjustment holes (**C**) in the mounting brackets.
3. Return the locking cams to their original position to lock the handle.

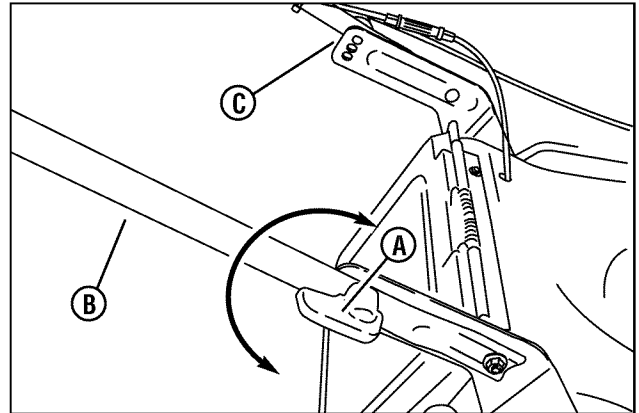

Figure 5: Adjusting the handle height

Stopping

1. Stop forward motion of the mower by releasing the wheel drive control.
2. Stop the engine and blade by releasing the blade control.



WARNING



DO NOT attempt any maintenance, adjustments or service with engine and blade running. STOP engine and blade. Disconnect spark plug wire and secure away from spark plug. Engine and components are HOT. Avoid serious burns, allow sufficient time for all components to cool.

WARNING

DO NOT attempt any maintenance, adjustments or service with engine and blade running. STOP engine and blade. Disconnect spark plug wire and secure away from spark plug. Engine and components are HOT. Avoid serious burns, allow sufficient time for all components to cool.

Cutting Height Adjustment

1. Pull the height adjusting lever (**A, Figure 6**) outward, and move to the desired cutting height. The highest cutting position is Notch 9 (**B; also see Figure 7**). The lowest cutting position is Notch 1 (**C**).

Note: The lever will set all wheels to the same cutting height.

WARNING

Stop engine and mower blade by releasing the blade control before adjusting cutting height.

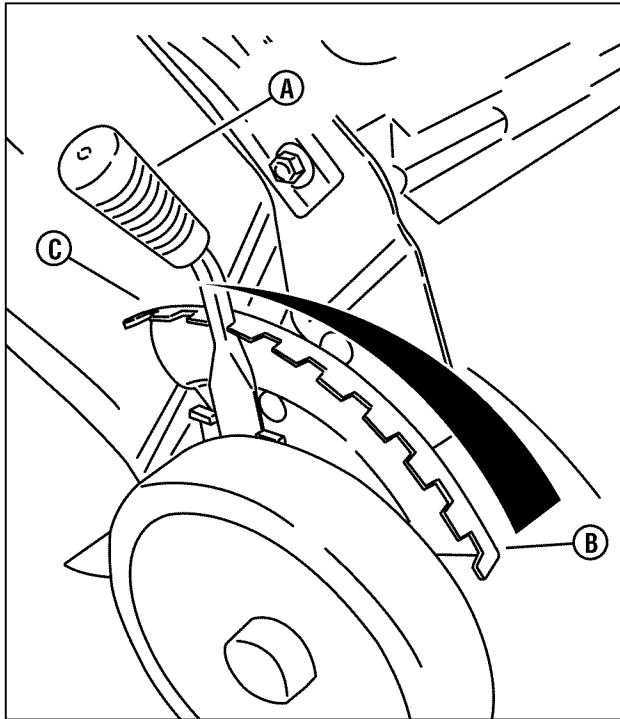

Figure 6: Adjusting cutting height

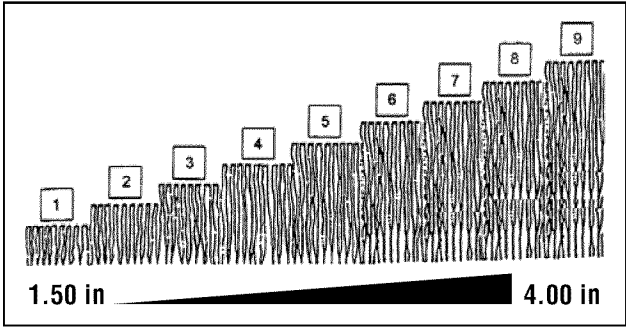

Figure 7: Cutting height settings (approximate)

Recycling Operation

Note: For best recycling results, cut up to a maximum of 1/3 of grass blade length and recycle ONLY when grass is dry.

1. Set the height adjustment lever in the highest cutting position (Notch 9). Refer to the Section entitled “Cutting Height Adjustment”.
2. Proceed mowing slowly. If the grass is very dense, lower the height adjustment lever one notch lower to improve recycling performance.

Installing the Discharge Deflector

1. Raise the recycling cover (**A, Figure 8**).

Important: The recycling cover should remain on the machine at all times. Do not remove.

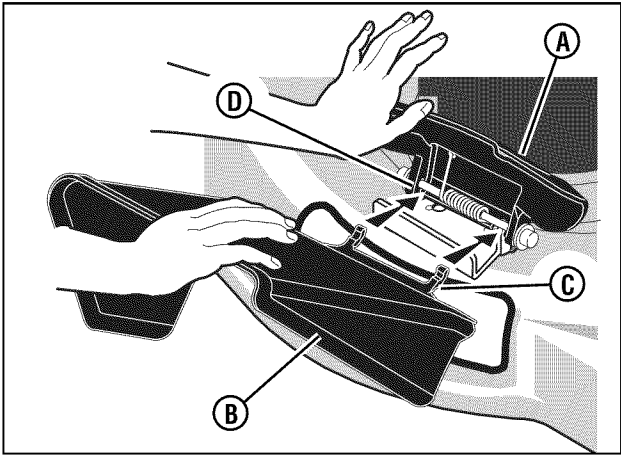

Figure 8: Installing the discharge deflector

2. Install the deflector (**B**) to the deck under the recycling cover, making sure that:
 - The tabs (**C**) hook under the pivot rod (**D**).
 - The locking tab on the deck (**A, Figure 9**) goes through the slot in the deflector (**B**).
3. Lower the recycling cover against the deflector.

Operation

! WARNING !
 DO NOT attempt any maintenance, adjustments or service with engine and blade running. STOP engine and blade. Disconnect spark plug wire and secure away from spark plug. Engine and components are HOT. Avoid serious burns, allow sufficient time for all components to cool.

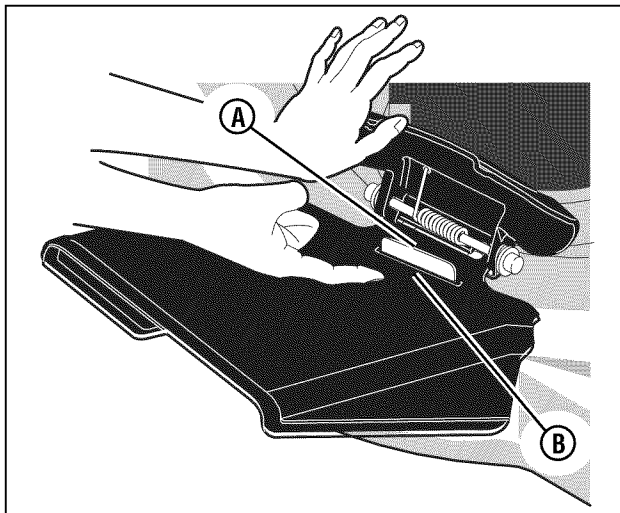

Figure 9: Deflector locking tab

Removing the Recycling Plug

1. Raise the rear discharge door (A, Figure 10).
2. Remove the recycling plug (B) from the rear discharge chute.

Note: The recycling plug should be removed only when bagging is desired, and should be replaced as soon as bagging operations are completed.

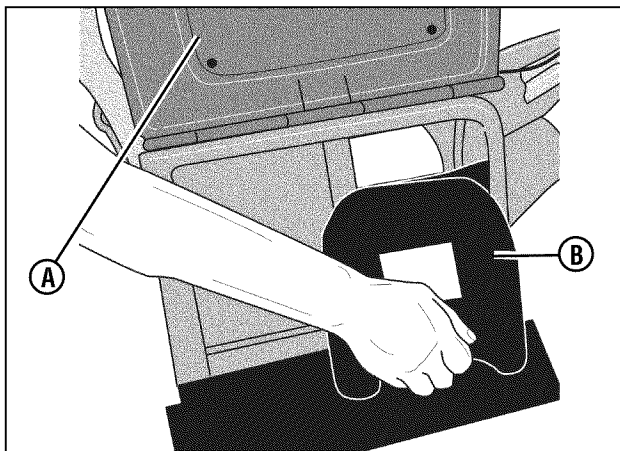

Figure 10: Removing the recycling plug

Installing the Grass Bag

1. Raise the rear discharge door (A, Figure 11).
2. Remove the recycling plug. Refer to the section entitled "Removing the Recycling Plug".
3. Holding the grass bag handle (B), install the grass bag onto the back of the mower, making sure that the grass bag hooks (A, Figure 12) are hooked onto the rear door pivot rod (B).

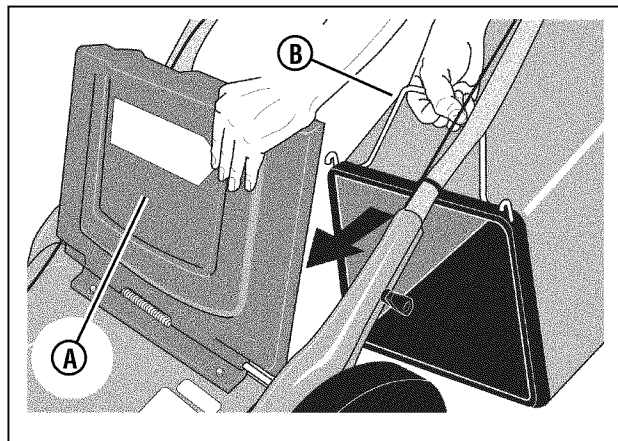

Figure 11: Installing the grass bag

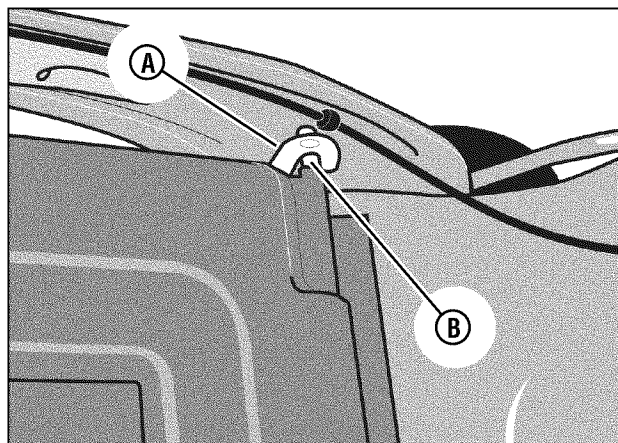

Figure 12: Grass bag hooks

! WARNING !
 Grass Catcher bags used on SNAPPER products are made of woven fabric, and are subject to deterioration and wear during normal usage. Check condition of bag before each use. Immediately replace worn or damaged catcher bags with only bags recommended by SNAPPER. The grass catcher is optional equipment on some models.

Maintenance - Introduction

To retain the quality of the mower, use genuine SNAPPER replacement parts only. Contact a local SNAPPER dealer for parts and service assistance. For the correct part or information for a particular mower, always mention the model and serial number.

! WARNING !

DO NOT attempt any maintenance, adjustments or service with engine and blade running. STOP engine and blade. Disconnect spark plug wire and secure away from spark plug. Engine and components are HOT. Avoid serious burns, allow sufficient time for all components to cool. Wear heavy leather gloves when handling or working around cutting blades. Blades are extremely sharp and can cause severe injury.

Service - After First 5 Hours

Change Engine Oil

1. Refer to the Engine Manual for proper oil specifications, procedures and proper service intervals.
2. For the simplest/cleanest oil change, simply turn the mower on its side to drain the oil, as shown. Drain the oil through the dipstick tube (A, Figure 13) into a container. Allow sufficient time for all the oil to drain.

Important: Drain the fuel tank before tipping the machine. DO NOT tip the machine with the carburetor or spark plug down. Oil from the crankcase will saturate the air filter and cause the engine to be hard to start or not start at all. If contamination does occur, the air filter will have to be replaced.

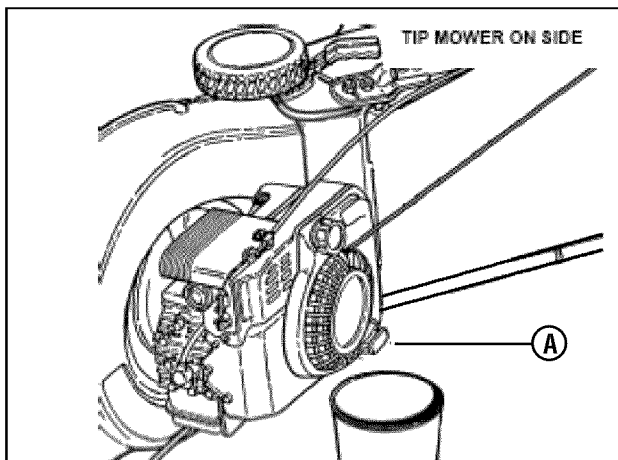

Figure 13: Draining the engine oil

3. Dispose of drain oil properly.
4. Fill the engine with oil as specified in the Engine Manual. Do Not overfill.

Check Mower Blade

1. Disconnect the spark plug wire and secure the end away from the plug.
2. Tilt the mower up on its rear wheels for access to the blade cap screw (A, Figure 14). Do not tilt the mower with the spark plug or carburetor down.

Important: Drain the fuel tank before tipping the mower. DO NOT tip the machine with the carburetor or spark plug down. Oil from the crankcase will saturate the air filter and cause the engine to be hard to start or not start at all. If contamination does occur, the air filter will have to be replaced.

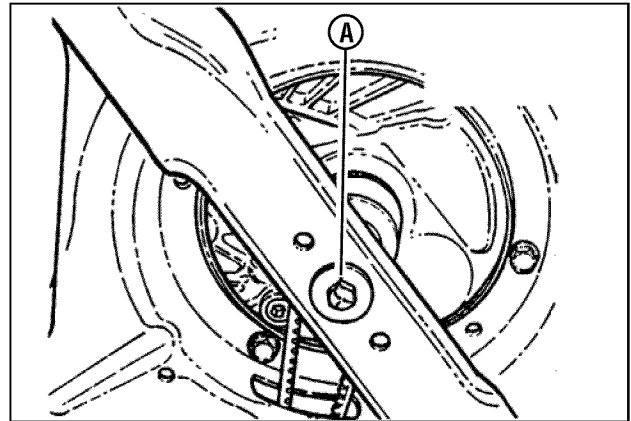

Figure 14: Tightening the blade cap screw

3. Check the torque of the blade cap screw. Recommended torque should be 40 ft. lbs.
4. Check the blade for sharpness, wear and damage. Refer to the Section entitled "Blade Wear Limits".

Check Engine Drive Belt

1. Visually check the engine drive belt for cracking, fraying, severed or exposed belt strands. If worn or damaged, replace the belt before operating the mower.

Service - Periodic

Perform all maintenance as described in the "Service Schedule" section of this manual.

Engine

Service the engine according to the engine owner's manual.

Air Filter

Refer to the engine owner's manual for service instructions.

Engine Oil

Refer to the engine owner's manual for service instructions.



WARNING



DO NOT attempt any maintenance, adjustments or service with engine and blade running. STOP engine and blade. Disconnect spark plug wire and secure away from spark plug. Engine and components are HOT. Avoid serious burns, allow sufficient time for all components to cool. Wear heavy leather gloves when handling or working around cutting blades. Blades are extremely sharp and can cause severe injury.

Wheel Drive Components

1. Remove the rear cover. Refer to the Section entitled “Rear Cover Removal & Installation”.
2. Clean any debris buildup on or around the transmission, axles, idler, pulleys, belt, etc., as well as on the inside of the cover. Check components for wear or damage. Replace worn or damaged components immediately.
3. Replace the rear cover.

Important: DO NOT operate the mower without the rear cover securely in place.

Storage Procedure

Refer to the Engine Owner’s Manual for directions regarding engine storage preparations. Prepare the mower for “end of season” storage as follows:

1. Drain the fuel from the fuel tank and let the engine run until all fuel is out of the carburetor.
2. Disconnect and remove the spark plug wire away from the spark plug before any other preparations are made!
3. Tape all openings closed to prevent spraying water into the exhaust or air intakes during washing.
4. Tilt the mower up on its rear wheels and thoroughly clean the underside of the deck. Do not tilt the mower with the spark plug or carburetor down. Scrape away any accumulation of grass with a putty knife and/or wire brush.
5. Lubricate all exposed metal with a light coating of oil to prevent corrosion.
6. Carefully fold the handles, “flexing” the control cables to prevent cable damage.
7. Store the mower in a shed or other dry area, protected from weather.

WARNING

DO NOT attempt any maintenance, adjustments or service with engine and blade running. STOP engine and blade. Disconnect spark plug wire and secure away from spark plug. Engine and components are HOT. Avoid serious burns, allow sufficient time for all components to cool. Wear heavy leather gloves when handling or working around cutting blades. Blades are extremely sharp and can cause severe injury.

Mower Blade Replacement

Standard Blade Wear Limit

1. Inspect the blade (**Figure 15**) frequently for signs of excessive wear or damage:
 - (A) New blade
 - (B) Wear limit (notch starts)
 - (C) Dangerous condition! Do not use on the mower! Replace with a new blade.

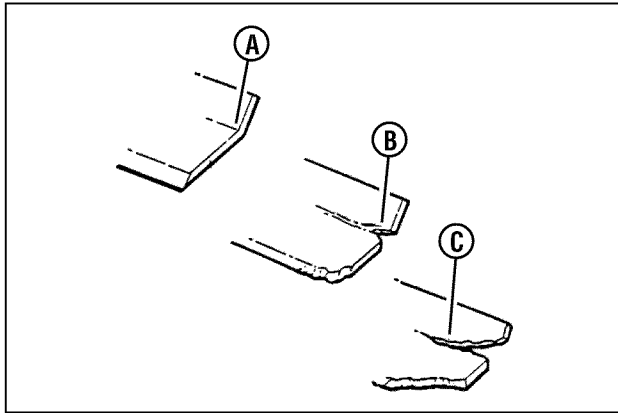

Figure 15: Mower blade wear limits

WARNING

DO NOT use a cutting blade that shows signs of excessive wear or damage. Refer to the Section entitled "MOWER BLADE REPLACEMENT" for proper blade inspection and service procedures.

Blade Sharpening

1. Disconnect the spark plug wire and secure the end away from the plug.
2. Tilt the mower up on its rear wheels. Do not tilt the mower with the spark plug or carburetor down.

Important: Drain the fuel tank before tipping the mower. DO NOT tip the machine with the carburetor or spark plug down. Oil from the crankcase will saturate the air filter and cause the engine to be hard to start or not start at all. If contamination does occur, the air filter will have to be replaced.

3. Remove the blade (**B, Figure 16**).

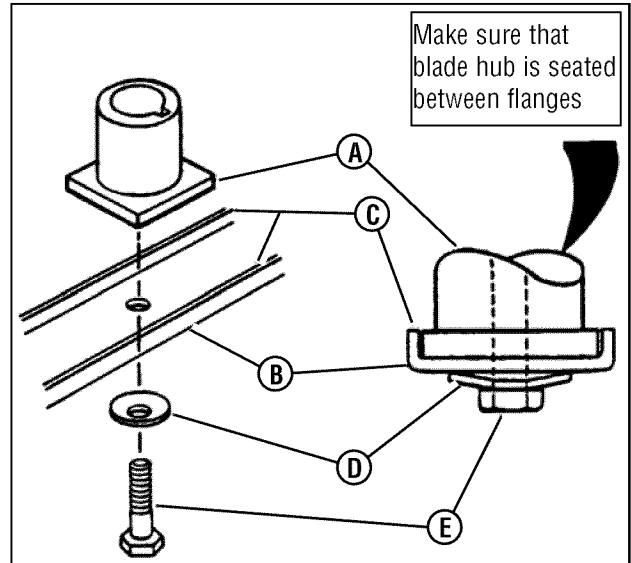

Figure 16: Removing the mower blade

4. Sharpen the blade on a grinding wheel at an angle of 22 to 28 degrees (**B, Figure 17**). DO NOT sharpen the blade beyond the original cutting edge (**A**).
5. Check blade for balance. If necessary, correct balance by grinding heavy end of blade.
6. Reinstall blade (**B, Figure 16**). Note the correct assembly order:
 - (A) Blade hub
 - (B) Blade
 - (C) Blade flange (facing up)
 - (D) Cone washer (concave side up)
 - (E) Capscrew
7. Check torque of blade retaining cap screw. Recommended torque should be 40 ft. lbs.

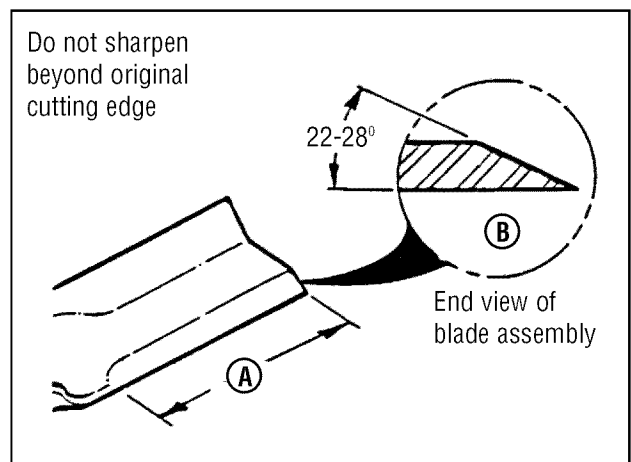

Figure 17: Sharpening the mower blade



WARNING



DO NOT attempt any maintenance, adjustments or service with engine and blade running. STOP engine and blade. Disconnect spark plug wire and secure away from spark plug. Engine and components are HOT. Avoid serious burns, allow sufficient time for all components to cool.

Wheel Drive Control Adjustment

The wheel drive control lever (**A, Figure 18**) should engage the transmission when the lever is squeezed back toward the handlebar, and should disengage the transmission when the lever is released.

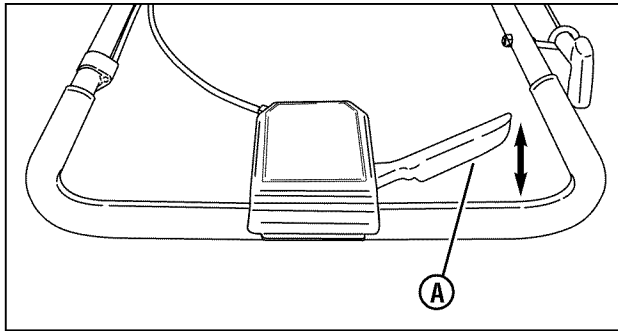

Figure 18: Wheel drive controls
(Components removed for clarity)

If the transmission does not engage or disengage, adjustment may be performed as follows:

1. Remove the rear cover from the mower. Refer to the section entitled "Rear Cover Removal & Installation".
2. With the wheel drive control lever in the 'DISENGAGE' position, the spring (**A, Figure 19**) on the end of the wheel drive control cable should have no tension. Measure the overall length of the unextended spring (**B**).

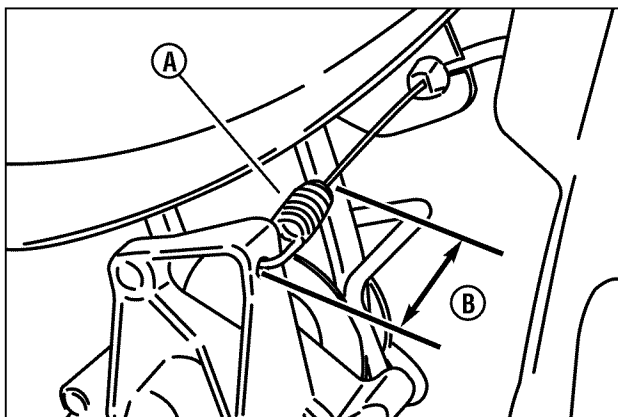

Figure 19: Measuring the disengaged transmission spring length

3. Fully engage the lever, and measure the length of the extended spring. The overall spring length should increase by 0.020 – 0.025".
4. To adjust spring extension:
 - a. Disengage the lever.
 - b. To increase (+) the extended spring length, loosen the jam nut (**B, Figure 20**) and rotate the ferrule (**C**) below the adjustment turnbuckle (**A**), located on the lower end of the wheel drive control cable, one-half turn out from the turnbuckle. Tighten the jam nut.
 - c. To decrease (-) the extended spring length, loosen the jam nut, and rotate the ferrule one-half turn in toward the turnbuckle. Tighten the jam nut.
5. Engage the lever and recheck the extended spring length. Repeat Step 4 as needed.

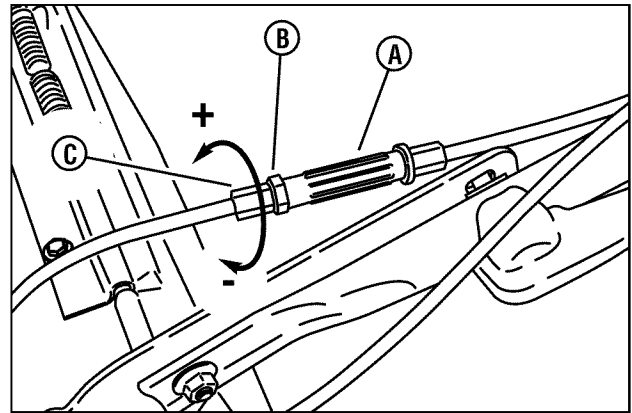

Figure 20: Adjusting the transmission spring tension

IMPORTANT: INCORRECT ADJUSTMENT CAN CAUSE PREMATURE WEAR AND/OR DAMAGE TO THE WHEEL DRIVE COMPONENTS.

⚠ WARNING ⚠

DO NOT attempt any maintenance, adjustments or service with engine and blade running. STOP engine and blade. Disconnect spark plug wire and secure away from spark plug. Engine and components are HOT. Avoid serious burns, allow sufficient time for all components to cool.

Belt Service

On self-propelled mowers, the engine belt transmits power from the engine to the transmission that powers the rear wheels. Should the belt become worn, it could cause slippage, which would impair mower performance. The condition of the engine belt should be checked after every 25 hours of mower operation.

Engine Drive Belt Replacement

1. Empty the fuel tank.
2. Remove the blade (**A, Figure 21**). Refer to the Section entitled "Blade Sharpening".
3. Remove the hardware (**B**) securing the two-piece belt cover beneath the deck. Remove the cover.
4. Remove the rear cover of the mower. Refer to the Section entitled "Rear Cover Removal & Installation".
5. To replace the belt:
 - a. Remove the hardware (**B, Figure 22**) securing the belt guide (**A**) to the transmission assembly. Remove the belt guide.
 - b. Remove the belt from the transmission and engine pulleys, noting the belt routing.
 - c. Replace the belt.
 - d. Replace the belt guide onto the transmission.
6. Replace the covers and blade.

Note: Recommended blade torque is 40 ft. lbs.

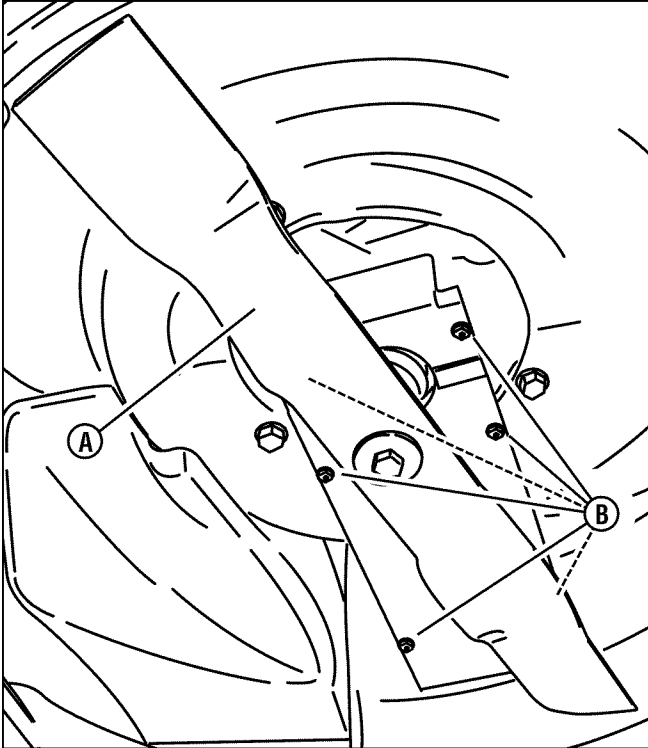

Figure 21: Removing the blade and belt cover

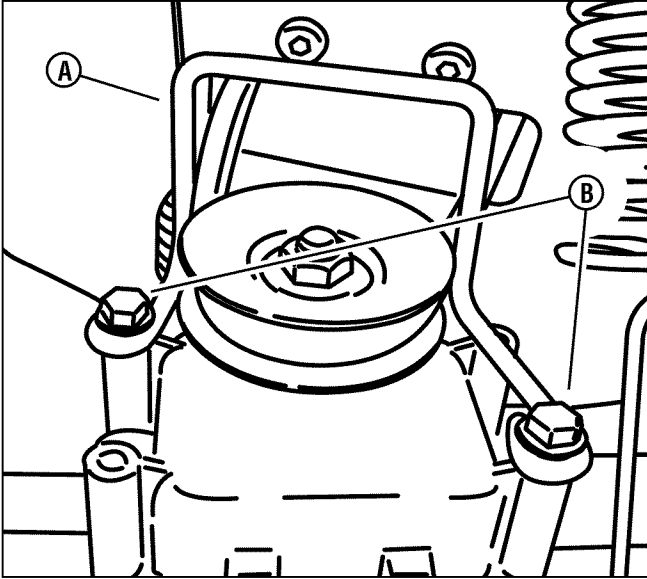

Figure 22: Removing the belt guide

**WARNING**

DO NOT attempt any maintenance, adjustments or service with engine and blade running. STOP engine and blade. Disconnect spark plug wire and secure away from spark plug. Engine and components are HOT. Avoid serious burns, allow sufficient time for all components to cool.

Battery Service**New Battery Preparation**

1. Remove the battery from the carton.
2. Place the battery in a well ventilated area on a level non-concrete surface.
3. Test the battery. Refer to the Section entitled “Battery Testing”. If the battery needs charging, charge the battery. Refer to the Section entitled “Battery Charging”.
4. Connect the positive (+) lead (red) first, from the battery harness to the positive terminal (+) on the battery using the bolt and nut plate supplied with the battery. Connect the negative (-) lead (black) last, to the negative terminal (-) on the battery using the bolt and nut plate. Apply a small amount of grease over the terminals to prevent corrosion.

NOTE: The battery may come with the harness already connected. If so, simply check to be sure the terminal hardware is securely tightened.

5. Install the battery onto the power unit.
6. Plug the main harness connector (A, Figure 23) into the battery harness connector (B).

**WARNING**

Shield the positive terminal with terminal cover located on battery harness. This prevents metal from touching the positive terminal, which could cause sparks.

Battery Service

1. Test the battery. Refer to the Section entitled “Battery Testing”. If the battery needs charging, charge the battery. Refer to the Section entitled “Battery Charging”.
3. If the battery will not accept a charge or is partially charged after charging per instructions, replace with a new battery.

Battery Storage

If the mower is to be stored out of season on its rear bumper, it is recommended the battery be removed, charged and stored.

1. Remove the battery.
2. Perform battery service. Refer to the Section entitled “Battery Service”.
3. Store the battery in an area away from the mower on a wood surface.

NOTE: Do not store the battery on a concrete surface.

Battery Testing

Check the battery’s state of charge using a voltmeter. Remember to hook the positive lead to the battery’s positive terminal, and the negative lead to the negative terminal. Check the reading against the chart below. If the voltage reads less than 12.80 volts, charge the battery. Refer to the Section entitled “Battery Charging”.

Battery Condition	
State of Charge	Digital Voltmeter
100% Charged	12.80v
75% Charged	12.40v
50% Charged	12.10v
25% Charged	11.90v
0% Charged	Less than 11.80v

Battery Charging

To charge the battery:

1. With the supplied DC charger: Plug the charger connector into the battery harness connector (B, Figure 23). Plug the charger into a wall outlet and charge the battery for 48 hours. (Longer periods will not damage the battery.)

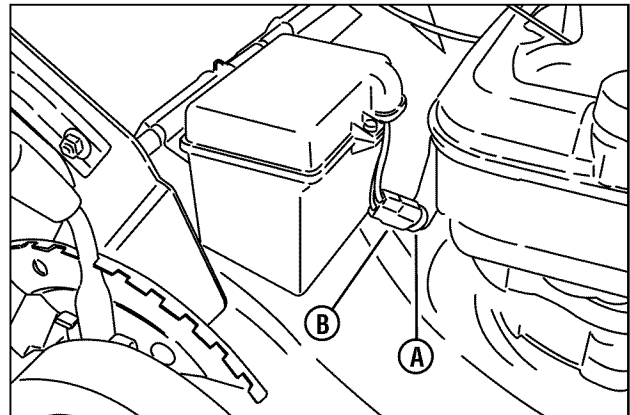

Figure 23: Battery connections

**WARNING**

Keep all sparks, flame and fire away from area when charging battery or when handling battery. Never use “BOOST” chargers on the battery.



WARNING



DO NOT attempt any maintenance, adjustments or service with engine and blade running. STOP engine and blade. Disconnect spark plug wire and secure away from spark plug. Engine and components are HOT. Avoid serious burns, allow sufficient time for all components to cool.

Rear Cover Removal and Installation

To Remove the Rear Cover

1. Remove the three fasteners **(A, Figure 24)** securing the rear apron to the machine.
2. Remove the two fasteners **(B)** securing the rear cover to the machine.
3. Slide the cover **(C)** down and out to remove. Set all components aside.

To Install the Rear Cover

1. Reverse steps 1-3 above, making sure the tab **(D)** on the rear cover is located on the outside of the machine.

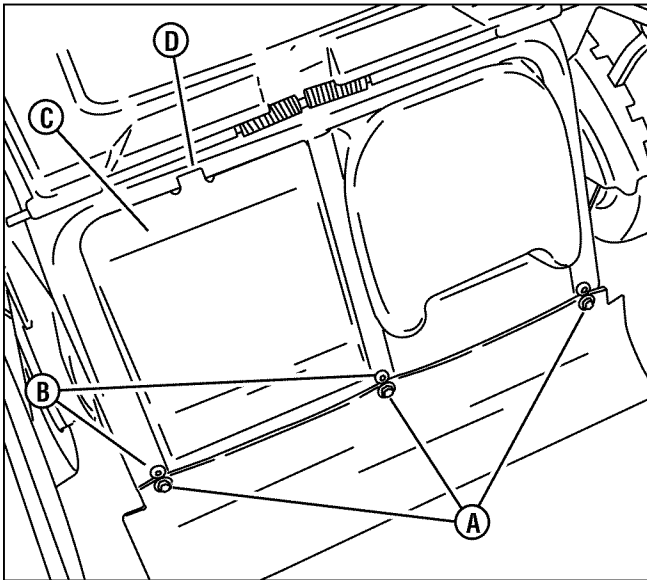

Figure 24: Removing the rear cover

Service Schedule

ITEM	SERVICE PERFORMED	REF.	EACH USE	5 HRS	25 HRS	50 HRS	100 HRS	EACH SEASON
Engine Oil	Check Oil Level	Page 5	X					
	Initial Oil Change	Page 9		X				
	Periodic Oil Change	Page 9			X*			
Air Pre-Cleaner	Clean Sponge Element	Engine Manual			X**			
Air Cleaner	Clean or Replace	Engine Manual			X**			
Spark Plug	Replace	Engine Manual					X	
Engine Cooling System	Clean Shroud & Fins	Engine Manual					X**	
Drive Belt	Check for Wear and Tension	Page 9, 13			X	X		X
Mower Blade	Check for wear, Damage & Replacement	Page 9, 11	X					
Mower Deck	Clean Debris Accumulation	Page 5	X					
Wheel Drive Components	Clean Debris Accumulation; Check for Wear or Damage	Page 10			X			
Transmission Cable Spring Adjustment	Check & Adjust	Page 12		X	X			X

*Change oil every 25 hours when operating under heavy load or high temperatures.

**Clean more often under dusty conditions or when air debris is present.

Maintenance

Maintenance/Replacement Parts

Blade Control Cable (SPV21675FC)	7101399
Blade Control Cable (SPV21675EFC)	7101400
Wheel Drive Control Cable	7101398
Cutter Blade (Double Wave)	7100242
Drive Belt	7100883
Parts Manual for Snapper 21" Variable Speed Walk Behind Mower	7102346

Troubleshooting

PROBLEM	PROBABLE CAUSE	CORRECTIVE ACTION
Engine Will Not Start Using Recoil Starter	<ol style="list-style-type: none"> 1. Fuel tank empty. 2. Engine needs priming. 3. Spark plug wire disconnected. 	<ol style="list-style-type: none"> 1. Fill fuel tank with fresh fuel. 2. Prime. Check Engine Manual for Instructions. 3. Place spark plug wire onto spark plug.
Engine Will Not Start (Electric Start Models)	<ol style="list-style-type: none"> 1. Fuel tank empty. 2. Engine needs priming. 3. Spark plug wire disconnected. 4. Wiring harness disconnected. 5. Battery dead. 	<ol style="list-style-type: none"> 1. Fill fuel tank with fresh fuel. 2. Prime. Check Engine Manual for Instructions. 3. Place spark plug wire onto spark plug. 4. Connect wiring harness. 5. Charge or replace battery.
Engine Stalls or Stops After Running	<ol style="list-style-type: none"> 1. Blade control is released or is not being held securely against handle. 2. Fuel tank empty. 3. Engine air pre-cleaner and or air cleaner dirty. 4. Spark plug defective or gap set improperly. 5. Water, debris or stale fuel in fuel system. 	<ol style="list-style-type: none"> 1. Blade control should be held securely against handle at all times during operation of mower. 2. Fill with fuel to proper level. 3. Clean free of all debris. 4. Service spark plug. 5. Drain and clean fuel system.
Engine Loses Power	<ol style="list-style-type: none"> 1. Engine air pre-cleaner or air cleaner dirty. 2. Spark plug faulty. 3. Water, debris or stale fuel in fuel system. 	<ol style="list-style-type: none"> 1. Clean or replace filters. 2. Service spark plug. 3. Drain and clean fuel system.
Excessive Vibration	<ol style="list-style-type: none"> 1. Damaged, out of balance or bent mower blade. 2. Loose blade components. 3. Loose or missing air lift (if equipped). 4. Lumpy or frayed belt. 	<ol style="list-style-type: none"> 1. Service mower blade. 2. Service and tighten loose parts. 3. Replace air lifts. Tighten to proper torque. 4. Replace belt.
Mower Will Not Move Loss Of Traction	<ol style="list-style-type: none"> 1. Build-up of debris on or around wheel drive components. 2. Transmission cable adjustment required. 3. Drive belt requires replacement. 4. Damaged transmission. 	<ol style="list-style-type: none"> 1. Clean debris. 2. Adjust transmission cable. 3. Replace drive belt. 4. Contact authorized SNAPPER dealer.
Transmission Noise	<ol style="list-style-type: none"> 1. Transmission cable adjustment required. 2. Damaged transmission. 	<ol style="list-style-type: none"> 1. Adjust transmission cable. 2. Contact authorized SNAPPER dealer.
Ground Speed Too Fast / Too Slow; Unable to Adjust Ground Speed	<ol style="list-style-type: none"> 1. Build-up of debris on or around wheel drive control components. 2. Transmission cable adjustment required. 3. Drive belt requires replacement. 4. Damaged transmission. 	<ol style="list-style-type: none"> 1. Clean debris. 2. Adjust transmission cable. 3. Replace drive belt. 4. Contact authorized SNAPPER dealer.
Cutting Grass Improperly	<ol style="list-style-type: none"> 1. Cutting height too low or high. 2. Forward speed too fast. 3. Cutting blade dull or damaged. 	<ol style="list-style-type: none"> 1. Adjust cutting height. 2. Adjust to a slower speed. 3. Sharpen cutting edges or replace blade.
Poor Grass Discharge	<ol style="list-style-type: none"> 1. Forward speed too fast. 2. Grass is wet. 3. Excessively worn or damaged blade. 4. Build up of grass clippings and debris under deck. 5. Improper blade installed on deck. 6. Blade installed improperly on deck. 	<ol style="list-style-type: none"> 1. Adjust to a slower speed. 2. Mow when grass is dry. 3. Service mower blade. 4. Clean deck. 5. Install proper SNAPPER blade. 6. Install blade properly.
Oil Leaking	<ol style="list-style-type: none"> 1. Leaking engine case. 	<ol style="list-style-type: none"> 1. Contact authorized SNAPPER dealer. 2. Check and tighten drain plug. 3. Make sure dip stick or oil filler cap is securely in place.

SNAPPER®

2 YEAR LIMITED WARRANTY

For two (2) years from purchase date for the original purchaser's residential, non-commercial use, SNAPPER, through any authorized SNAPPER dealer will replace, free of charge (except for taxes where applicable), any part or parts found upon examination by the factory at McDonough, Georgia, to be defective in material or workmanship or both.

For ninety (90) days from purchase date for the original purchaser's commercial, rental, or other non-residential use, SNAPPER, through any authorized SNAPPER dealer will replace, free of charge, any part or parts found upon examination by the factory at McDonough, Georgia, to be defective in material or workmanship or both.

All transportation costs incurred by the purchaser in submitting material to an authorized SNAPPER dealer for replacement under this warranty must be paid by the purchaser.

This warranty does not apply to certain transmissions, to engines and their components, and batteries, as these items are warranted separately. This warranty does not apply to parts that have been damaged by accident, alteration, abuse, improper lubrication, normal wear, or other cause beyond the control of SNAPPER. This warranty does not cover any machine or component part that has been altered or modified changing safety, performance, or durability.

Batteries have a one (1) year warranty period with free replacement if required for one (1) year from the original purchase date. SNAPPER will not be responsible for any installation cost incurred. The battery warranty only covers original equipment batteries and does not cover damage to the battery or machine caused by neglect or abuse, destruction by fire, explosion, freezing, overcharging, improper maintenance, or use of improper electrolyte.

There is no other express warranty.

DISCLAIMER OF WARRANTY

Implied warranties, including those of merchantability and fitness for a particular purpose, are limited to two (2) years from purchase date for the original purchaser's residential or other non-commercial use, and ninety (90) days from purchase for the original purchaser's commercial, rental or other non-residential use, and to the extent permitted by law, any and all implied warranties are excluded. This is the exclusive remedy. Liabilities for consequential damages, under any and all warranties are excluded.

Some states do not allow limitations on how long an implied warranty lasts, or do not allow the exclusion or limitation of incidental or consequential damages, so the above limitation or exclusion may not apply to you.

This warranty gives you specific legal rights, and you may also have other rights which vary from state to state.

WARNING: THE USE OF REPLACEMENT PARTS OTHER THAN GENUINE SNAPPER PARTS MAY IMPAIR THE SAFETY OF SNAPPER PRODUCTS AND WILL VOID ANY LIABILITY AND WARRANTY BY SNAPPER ASSOCIATED WITH THE USE OF SUCH PARTS.

IMPORTANT: Please fill out the attached SNAPPER Product Registration Card immediately and mail to:
Snapper's Product Registration Center, P.O. Box 1379, McDonough, Georgia 30253

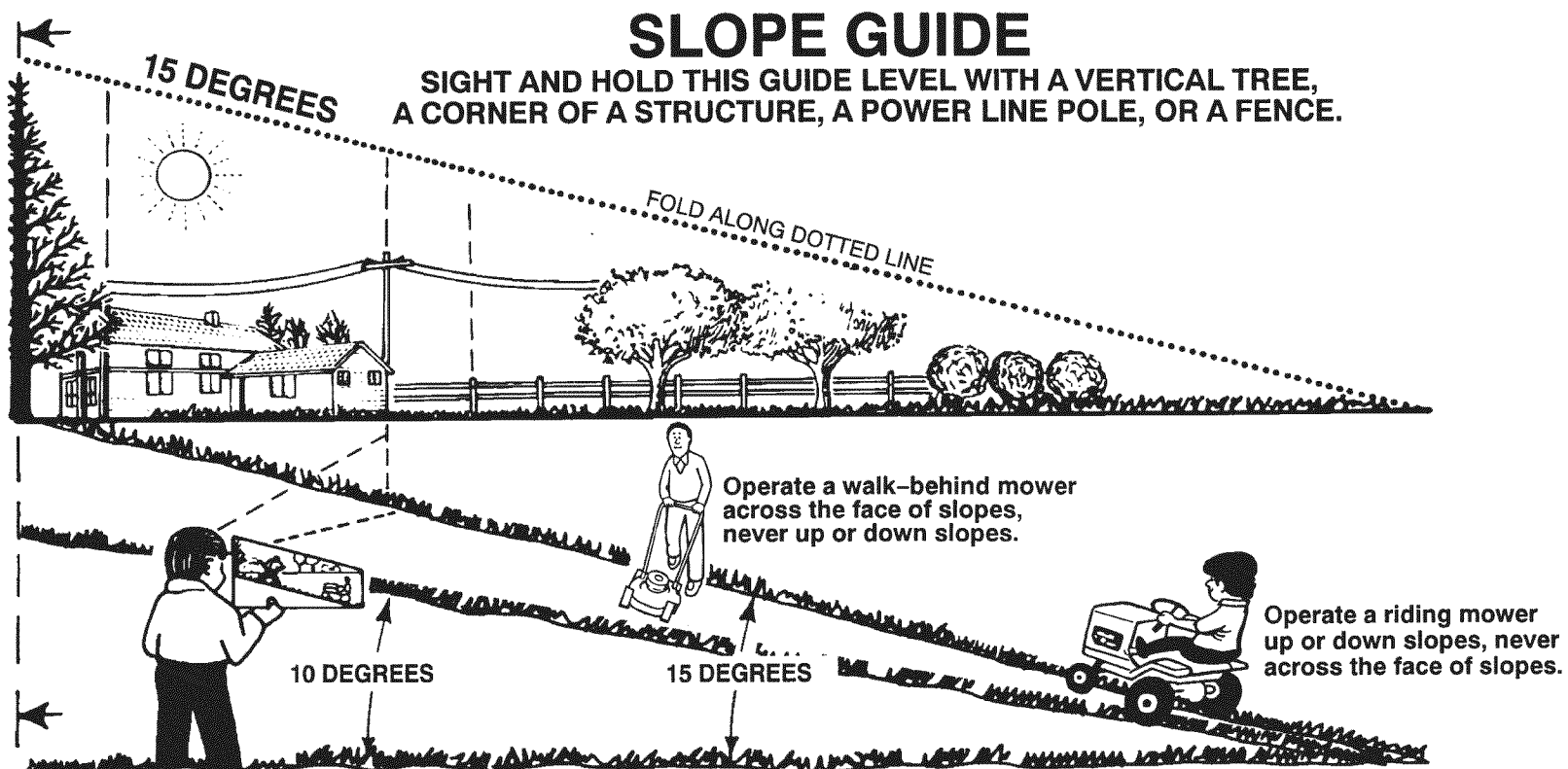

On a riding mower to determine if a slope is safe to mow: (1) disengage the blade(s), (2) put the unit in reverse, and (3) try to back straight up the slope. If you can back up the slope, it is generally safe to mow. However, if you do not feel safe, or if you are not completely sure, use this guide and do not mow a slope that is greater than 15 degrees. If the riding mower is used with a pull-behind or rear mounted attachment, do not operate the unit on a slope that is greater than 10 degrees.

A 15 degree slope is a hill that increases in height at approximately 2.5 feet in 10 feet.
A 10 degree slope is a hill that increases in height at approximately 1.7 feet in 10 feet.



Use extreme care at all times, and avoid sudden turns or maneuvers. Follow other instructions in this manual for safety in mowing on slopes. Operate a riding mower up or down slopes, never across the face of slopes. Operate a walk-behind mower across the face of slopes, never up or down slopes. Use extra care when operating on or near slopes and obstructions.

CUT HERE TO USE SLOPE GUIDE

SNAPPER®

21" VARIABLE SPEED REAR DISCHARGE WALK BEHIND MOWERS

Product Specifications (All)

Deck Size (in)	21
Height of Cut (in)	1.25 - 4
Transmission Type	Variable Speed/Gear
Ground Speed (mph)	0 - 4.2
Engine Power (ft-lbs)	6.75
Engine Displacement (cc)	190
Fuel Tank Capacity (qt)	1.6

Common Service Parts

Blade Control Cable (SPV21675FC)	7101399
Blade Control Cable (SPV21675EFC)	7101400
Wheel Drive Control Cable	7101398
Cutter Blade (Double Wave)	7100242
Drive Belt	7100883
Parts Manual	7102346

Part Number

Engine Power Rating Information: The gross power rating for individual gas engine models is labeled in accordance with SAE (Society of Automotive Engineers) code J1940 (Small Engine Power & Torque Rating Procedure), and rating performance has been obtained and corrected in accordance with SAE J1995 (Revision 2002-05). Torque values are derived at 3060 RPM; horsepower values are derived at 3600 RPM. Actual gross engine power will be lower and is affected by, among other things, ambient operating conditions and engine-to-engine variability. Given both the wide array of products on which engines are placed and the variety of environmental issues applicable to operating the equipment, the gas engine will not develop the rated gross power when used in a given piece of power equipment (actual "on-site" or net horsepower). This difference is due to a variety of factors including, but not limited to, accessories (air cleaner, exhaust, charging, cooling, carburetor, fuel pump, etc.), application limitations, ambient operating conditions (temperature, humidity, altitude), and engine-to-engine variability. Due to manufacturing and capacity limitations, Briggs & Stratton may substitute an engine of higher rated power for this Series engine.