

Design Guide with
**Installation
Instructions**

Wine Chiller, Wine Reserve
and Beverage Center

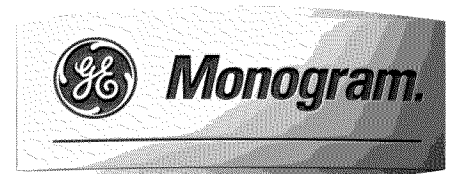

Safety Information

BEFORE YOU BEGIN:

Read these instructions completely and carefully.

IMPORTANT — Save these instructions for local inspector's use.

IMPORTANT — Observe all governing codes and ordinances.

Note to Installer – Be sure to leave these instructions with the Consumer.

Note to Consumer – Keep these instructions with your Owner's Manual for future reference.

⚠ WARNING – This appliance must be properly grounded. See page 5.

⚠ AVERTISSEMENT – Cet appareil doit être correctement mis à la terre. Consultez page 5.

If you received a damaged wine chiller, wine reserve or beverage center, you should immediately contact your dealer or builder.

Skill Level – Installation requires basic mechanical skills. Proper installation is the responsibility of the installer. Product failure due to improper installation is not covered under the GE Appliance Warranty.

⚠ WARNINGS:

- Use this appliance only for its intended purpose.
- Immediately repair or replace electrical service cords that become frayed or damaged.
- Unplug the unit before cleaning or making repairs.
- Repairs should be made by a qualified service technician.

⚠ AVERTISSEMENT :

- Il ne faut utiliser cet appareil que pour l'usage pour lequel il a été construit.
- Il faut réparer ou remplacer immédiatement tout cordon d'alimentation électrique effiloché ou endommagé.
- Débrancher le bar ou le réfrigérateur à vin avant le nettoyage ou toute intervention.
- Les réparations doivent être faites par un technicien qualifié.

For Monogram local service in your area, call 1.800.444.1845

For Monogram service in Canada, call 1.800.561.3344

For Monogram Parts and Accessories, call 1.800.626.2002.

www.monogram.com

CONTENTS

Design Guide

The Installation Space.....	3
Side-by-Side Installations	4
Product Clearances.....	4

Installation Instructions

Tools Required.....	5	Step 5, Slide Product into Cutout.....	7
Grounding the Product	5	Step 6, Install Nameplate.....	7
Staining Wood Drawer Fronts	5	Step 7, Set Temperature Controls.....	7
Installing the Custom Frame Panel ...	5	Custom Frame Panel Models.....	7
Step 1, Remove Packaging	5	Template for Nameplate....	Back Cover
Step 2, Reverse Door Swing.....	6		
Step 3, Level	7		
Step 4, Connect Power.....	7		

Design Guide

THE INSTALLATION SPACE

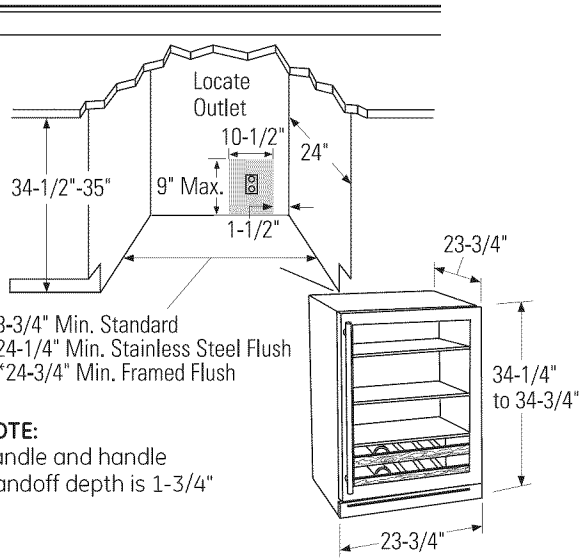

- *23-3/4" Min. Standard
- **24-1/4" Min. Stainless Steel Flush
- ***24-3/4" Min. Framed Flush

NOTE:
Handle and handle
standoff depth is 1-3/4"

***For a standard installation of Custom-Framed unit:** The product must be installed so that the front face will project 2" forward of adjacent cabinets. This position will allow a full door swing and prevent interference with adjacent cabinetry. The opening between cabinets must be 23-3/4" minimum.

****For a standard installation of Stainless Steel unit:** The product must be installed so that the front face will project 1-3/4" forward of adjacent cabinets. This position will allow a full door swing and prevent interference with adjacent cabinetry. The opening between cabinets must be 23-3/4" minimum.

*****For a flush installation of Stainless Steel unit:** Install a 1/2"-wide filler strip on the hinge side. The filler strip will act as a spacer between the door case and adjacent cabinets and will prevent interference with the cabinet door swing. Recess the filler strip 2" back from the front face of the unit, or even with the front edge of the product case (behind the gasket). The width of the opening must be 24-1/4" (including the 1/2" filler strip).

*****For a flush installation of Custom-Framed unit:** Install a 1"-wide filler strip on the hinge side. The filler strip will act as a spacer between the door case and adjacent cabinets and will prevent interference with the cabinet door swing. Recess the filler strip 2" back from the front face of the unit, or even with the front edge of the product case (behind the gasket). The width of the opening must be 24-3/4" (including the 1" filler strip).

- The wine chiller, wine reserve and beverage center can be installed freestanding.

Additional Specifications

- A 120 volt 60Hz., 15 or 20 amp power supply is required. An individual properly grounded branch circuit or circuit breaker is recommended. Install a properly grounded 3-prong electrical receptacle recessed into the back wall as shown. Electrical must be located on rear wall as shown.

NOTE: GFI (ground fault interrupter) is not recommended.

THE INSTALLATION SPACE (cont.)

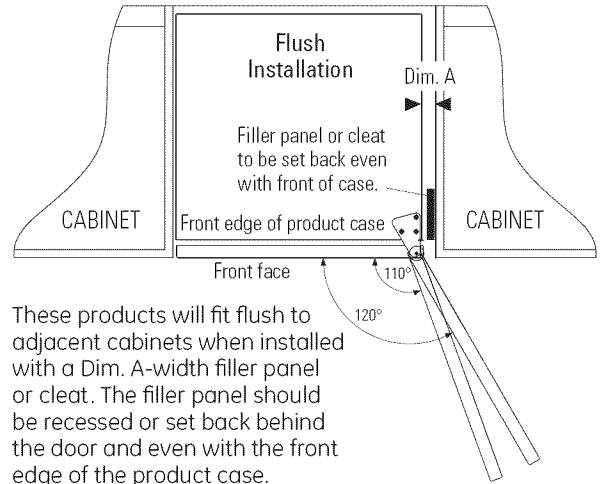

These products will fit flush to adjacent cabinets when installed with a Dim. A-width filler panel or cleat. The filler panel should be recessed or set back behind the door and even with the front edge of the product case.

Product	Dim. A
ZDWI240, ZDBI240	1"
ZDWC240, ZDWR240	1/2"
ZDBC240, ZDBR240	1/2"

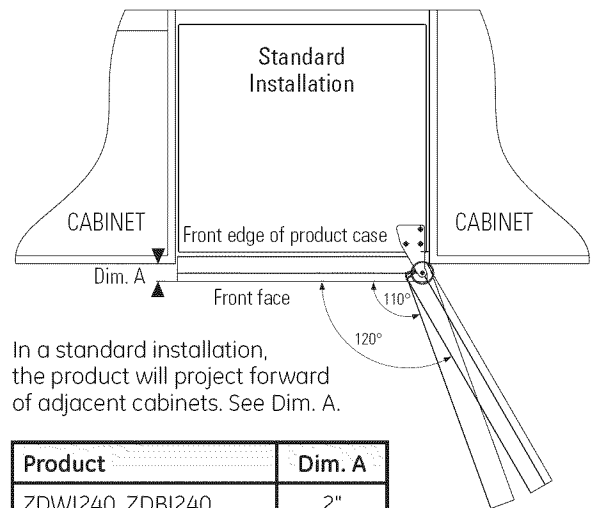

In a standard installation, the product will project forward of adjacent cabinets. See Dim. A.

Product	Dim. A
ZDWI240, ZDBI240	2"
ZDWC240, ZDWR240	1-3/4"
ZDBC240, ZDBR240	1-3/4"

Design Guide

SIDE-BY-SIDE INSTALLATIONS

Increase storage capacity by installing two Monogram beverage centers, wine chillers or wine reserves together. Or, for a complete refreshment center, install any two of these units together.

- A side-by-side installation requires at least a 47-1/2"-wide minimum opening for standard installation and a 48-1/2"-wide minimum opening for flush installation of stainless steel models. A 49-1/2"-wide minimum opening is required for side-by-side flush installation of custom framed models.
- Products must operate from separate, properly grounded receptacles.

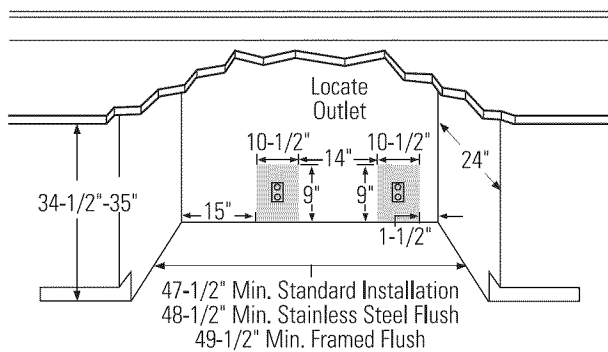

PRODUCT CLEARANCES

The stainless steel wine chiller, wine reserve and beverage center is factory set for a 110° door swing. Models that accept custom panels have a 95° door swing.

When installed in a corner:

- Allow 4" min. clearance on the hinge side for the 90° door swing and to allow racks to slide out.
- Allow 10" minimum clearance on the hinge side for a full 110° door swing. (Models ZDWI240WII and ZDBI240WII have a 95° door swing.)

NOTE: Custom handle clearances may vary, depending on custom handle depth.

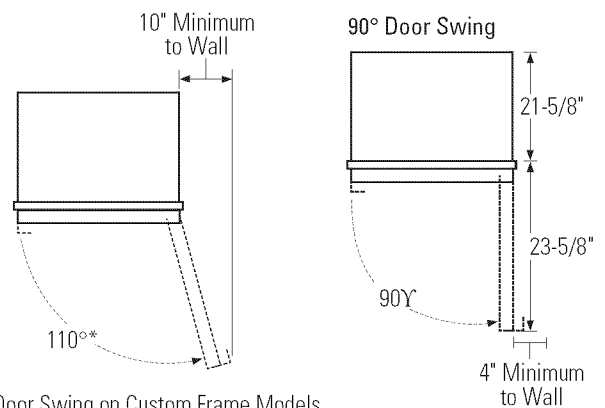

*95° Door Swing on Custom Frame Models

- The door swing is reversible on all models. If desired, change the door swing before installation or before installing the custom frame panel.

Choose the location:

- These products may be closed in on the top and three sides as long as the front is unobstructed for air circulation and proper access to the door.
- Do not install these products where the temperature will go below 55°F (13°C) or above 90°F (32°C).
- Do not install where it will be subject to direct sunlight, heat or moisture.
- These products are not designed to be stacked one over the other.

Black or Stainless Steel Toekick Options

- These products are shipped with a black toekick installed. An optional stainless steel toekick is also supplied with each product. For shipping purposes, the stainless steel toekick is secured to the back of the unit.

Installation Instructions

TOOLS REQUIRED

- #2 Phillips screwdriver
- Adjustable wrench

PARTS SUPPLIED

- Monogram nameplate
- Hardware for changing door swing
- Optional stainless steel toekick with screws and spacers
- Left and right side hinge covers
- Top screw hole cover

GROUNDING THE WINE CHILLER, WINE RESERVE AND BEVERAGE CENTER

IMPORTANT – Please read carefully.

FOR PERSONAL SAFETY, THIS APPLIANCE MUST BE PROPERLY GROUNDED.

The power cord of this appliance is equipped with a three-prong (grounding) plug which mates with a standard three-prong (grounding) wall receptacle to minimize the possibility of electric shock hazard from this appliance.

Have the wall outlet and circuit checked by a qualified electrician to make sure the outlet is properly grounded.

Where a standard 2-prong wall outlet is encountered, it is your personal responsibility and obligation to have it replaced with a properly grounded 3-prong wall outlet.

DO NOT, UNDER ANY CIRCUMSTANCES, CUT OR REMOVE THE THIRD (GROUND) PRONG FROM THE POWER CORD.

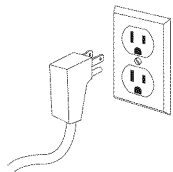

DO NOT USE AN ADAPTER PLUG TO CONNECT THE REFRIGERATOR TO A 2-PRONG OUTLET.

DO NOT USE AN EXTENSION CORD WITH THIS APPLIANCE.

STAINING WOOD DRAWER FRONTS

The drawer fronts are unfinished cherry wood. During use, oil from hands may accumulate and stain the wood.

- The drawer fronts may be stained and sealed to match adjacent cabinetry. The tinted glass will make the stained wood appear darker. A true color match can be seen only when the door is opened.
- Apply the stain and sealer according to the manufacturer's instructions. To avoid unpleasant odor, keep the door open to ventilate and allow the stain/sealer to dry completely before using the product.

INSTALLING THE CUSTOM FRAME PANEL

Go to page 6 for custom frame panel size, depending on your cabinet size and style.

- Install a custom handle of your choice onto the custom panel before the panel is secured to the door.
- The custom panel should be installed before sliding the product into the installation location.

STEP 1 REMOVE PACKAGING

- Remove corner blocks and foam drawer stops.
- Remove all packing material, tape and protective plastic coverings.
- Remove stainless steel toekick taped to the back of the unit.

⚠ CAUTION: Small objects are a choke hazard for children. Remove and discard any parts not used.

⚠ MISE EN GARDE : Les petits objets peuvent étrangler les enfants. Il faut jeter toutes les pièces qui ne sont pas utilisées.

Installation Instructions

STEP 2 REVERSE DOOR SWING

SKIP THIS STEP IF DOOR SWING SUITS THE INSTALLATION

Parts Included:

- Top left case hinge
- Bottom left case hinge
- Left and right side decorative hinge cover
- Decorative hinge screw hole cover
- Torx® driver bit

Tools Required:

- Phillips screwdriver
- Electric drill

Remove the door:

- Flatten the shipping carton to use as a pad.
- Remove the 2 screws and the toekick. Set aside the screws and toekick for final installation.
- Use the supplied Torx® bit and electric drill to remove the 3 screws holding the top case hinge. Lift off the hinge. (Screws will be used to install the new hinge.)
- Lift the door off the bottom case hinge.
- Remove the bottom case hinge pin and bracket.

Rotate the door:

The handle will be on the right side of the door; hinges will be installed on the left side of the case.

- Remove the door stop and cam riser on the original bottom right side of the door.
- Remove the fill plug on the top right side of the door.
- Turn the door over and reinstall the fill plug on the new left side.

Reinstall the door:

- Install the original door stop and cam riser onto the bottom left side of the door.
- Install the new supplied bottom case hinge pin and bracket onto bottom left side.
- Place the door onto the bottom case hinge.
- Install the supplied left-hand top case hinge with the 3 original screws.
- Select the hinge cover marked with an "L".
- Peel backing off the tape inside the decorative hinge cover.
- Press and snap the hinge cover into place.
- Snap the screw hole cover into place on the opposite side.

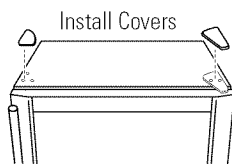

IMPORTANT:

Check to be sure screws are tight and that the door is straight and does not sag. The door should swing freely.

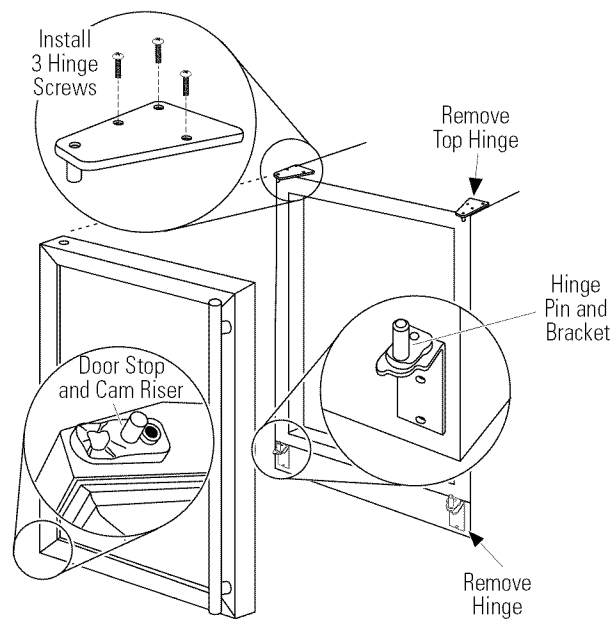

Apply Monogram Nameplate:

- Install the Monogram nameplate. See instructions and template on back cover.

Install Toekick

The toekick has a cutout on the left and right sides.

Remove the plug on the left side and reinstall on the right side. If you choose to install the stainless steel toekick, reinstall the plug on the right side of that toekick.

- Install original screws and spacers or screws and spacers supplied with the stainless steel toekick. Install screws through the spacer standoff, toekick and into the base as shown.

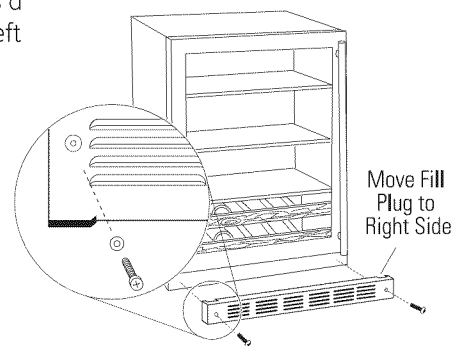

Installation Instructions

STEP 3 LEVEL

- Use an adjustable wrench to turn the leveling legs and raise or lower the product.
- Adjust carefully; the product should be level and plumb with cabinetry, and should align with adjacent toekick height.

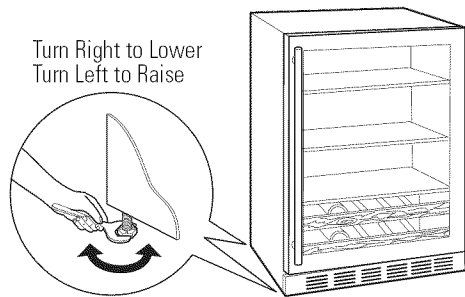

If you skipped Step 2:

- Select the hinge cover marked "R" or "L", depending on door swing.
- Peel backing off the tape inside the decorative hinge cover. Press and snap into position.
- Snap the screw hole cover into place on the opposite side.

STEP 4 CONNECT POWER

- Connect power cord plug to a properly grounded receptacle.
- Check to make sure power is on by opening the door to see if interior light turns on.

STEP 5 SLIDE PRODUCT INTO THE CUTOUT

- Carefully, slide the unit into the opening. Be careful not to entangle the power cord.
- Make certain that the door protrudes 1" beyond the surrounding cabinets (1-7/8" for custom frame models).
- Check again to be sure the unit is level.

STEP 6 INSTALL NAMEPLATE

- Follow instructions on the back page for installation of the Monogram nameplate.

STEP 7 SET TEMPERATURE CONTROLS

- The temperature controls are preset. Refer to the Owner's Manual for more information. Allow 24 hours for temperature to stabilize.

CUSTOM FRAME PANEL MODELS

Model ZDWI240WII and ZDBI240WII

These models require a custom panel frame surrounding the glass. There are two options: the panel may be 29-3/4" or 30" high. A 30" panel requires a notch cut into the bottom of the panel to avoid interference with the hinges.

- Rout the back side of the panel to the dimensions shown.
- A custom handle of your choice must be installed before the panel is mounted onto the door.

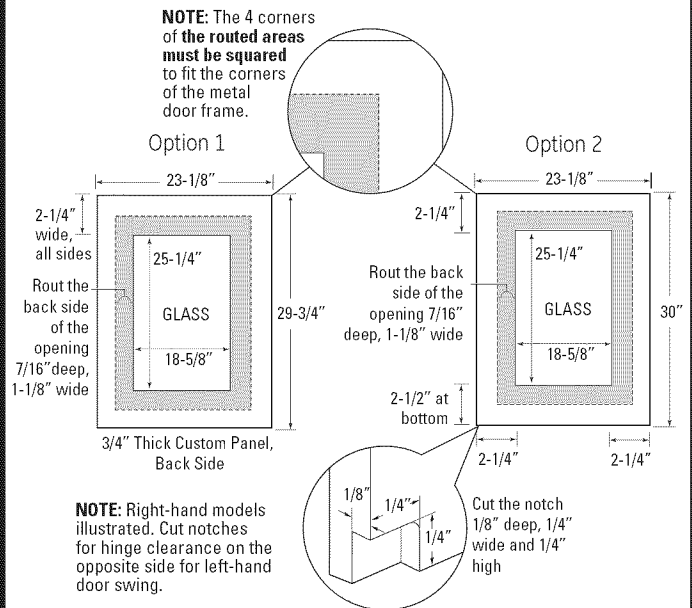

Choose Option 1 or Option 2 panel size depending on cabinetry size or style.

NOTE: A solid panel that covers the door glass CANNOT be installed on these models.

Install the custom panel:

- Open the door fully.
- Remove the gasket surrounding the inside of the door to expose the existing screw holes for the custom panel.
- Hold the custom frame panel against the door and align carefully, top to bottom and side to side. Mark screw hole locations on the back side of the panel.
- Drill pilot holes in the back side of the custom panel. In hardwood, drill 3/32" pilot holes. In softwood, drill 5/64" holes.
- Secure the prepared panel to the door using ten (10) #8 x 5/8" screws. Drive the screws through the door frame and into the wood.
- Replace the gasket.

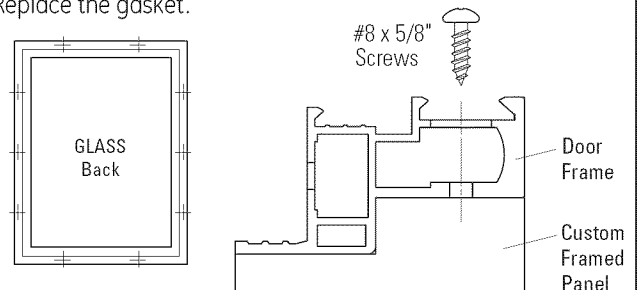

TEMPLATE FOR NAMEPLATE LOCATION

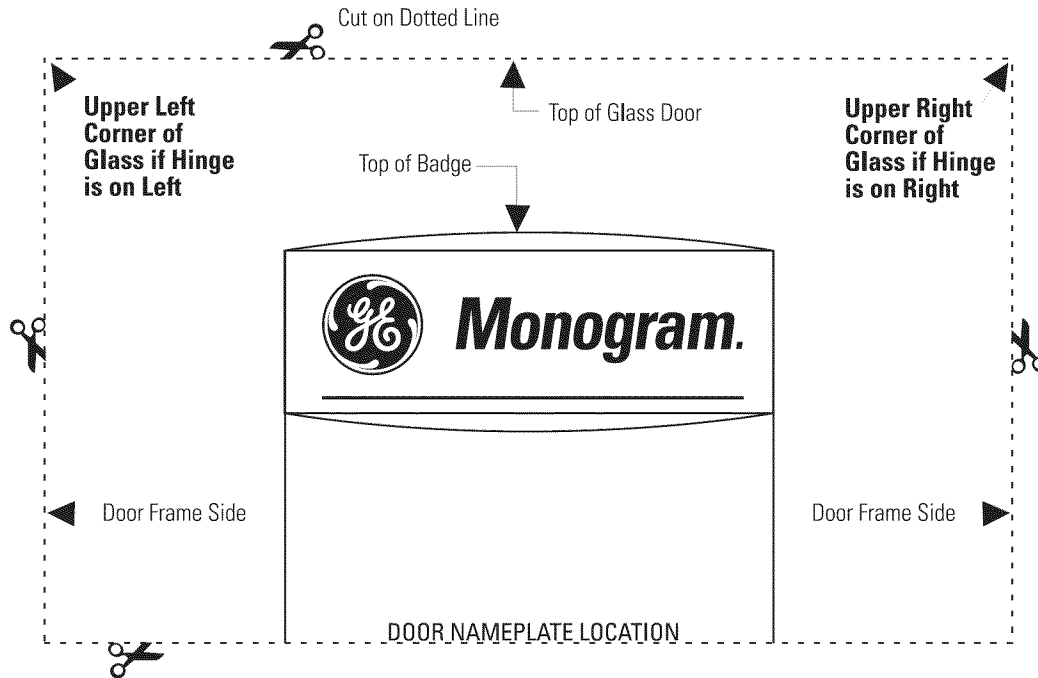

To position nameplate:

- Cut template along dotted line.
- Hold or tape template behind glass door so that it is visible from the front side.
- Remove backing from nameplate.
- Place nameplate onto front side of door, matching illustration on the template.

IMPORTANT: Nameplate must be placed on the opposite side of the door handle.

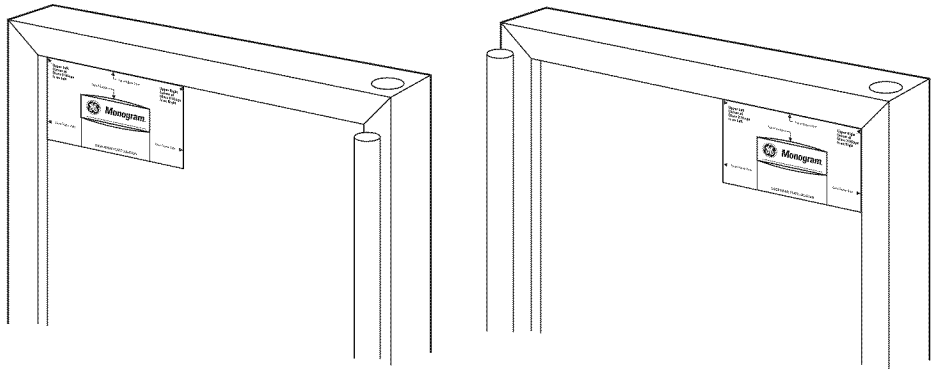

Note: While performing installations described in this book, safety glasses or goggles should be worn.

For Monogram® local service in your area, call 1.800.444.1845.

Note: Product improvement is a continuing endeavor at General Electric. Therefore, materials, appearance and specifications are subject to change without notice.

Pub. No. 31-46122-3
Part No. 197D7840P001

09-09 JR
Printed in Slovenia



GE Consumer & Industrial
Appliances
General Electric Company
Louisville, KY 40225
GEAppliances.com