

# AD6 **SCHWINN**®

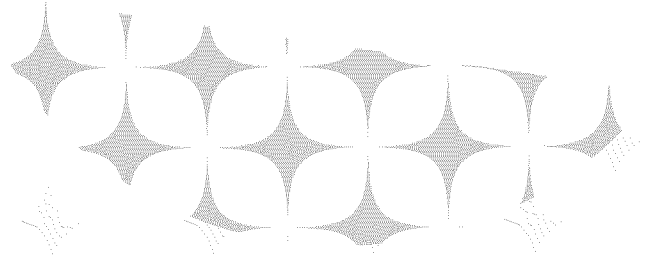

Manual en Español Latino Americano:  
<http://www.schwinnfitness.com>

**ASSEMBLY MANUAL / OWNER'S MANUAL**

# TABLE OF CONTENTS

Important Safety Instructions - Assembly	3	Adjustments	18
Safety Warning Labels / Serial Number	4	Using the Machine	18
Specifications	5	Locking the Fan Assembly / Storage	19
Before Assembly	5	Power Up / Idle Mode	19
Parts	6	Initial Setup	20
Hardware	7	Quick Start Program	20
Tools	7	Custom Time Workout	20
Assembly	8	Pausing or Stopping	20
Moving the Machine	13	Results Mode	20
Leveling the Machine	13	Console Service Mode	21
		Maintenance	22
Important Safety Instructions	14	Replacing the Console Batteries	23
Features	15	Maintenance Parts	24
Console Features	16	Troubleshooting	25
Remote Heart Rate Monitor	17	Warranty	27
Operations	18		

To validate warranty support, keep the original proof of purchase and record the following information:

**Serial Number** \_\_\_\_\_

**Date of Purchase** \_\_\_\_\_

To register your product warranty, go to: [www.SchwinnFitness.com/register](http://www.SchwinnFitness.com/register)

Or call 1 (800) 605-3369.

If you have questions or problems with your product, please call 1 (800) NAUTILUS (628-8458).

Nautilus, Inc., (800) NAUTILUS / (800) 628-8458, [www.NautilusInc.com](http://www.NautilusInc.com) - Customer Service: North America (800) 605-3369, [csnls@nautilus.com](mailto:csnls@nautilus.com) | outside U.S. +01-360-859-5180, [technics-APLA@nautilus.com](mailto:technics-APLA@nautilus.com) | Printed in China | © 2012 Nautilus, Inc.



This icon means a potentially hazardous situation which, if not avoided, could result in death or serious injury.

**Obey the following warnings:**



Read and understand all warnings on this machine.

Carefully read and understand the Assembly instructions.

- Keep bystanders and children away from the product you are assembling at all times.
- Do not install the batteries into the machine until the time specified in the assembly manual.
- Do not assemble this machine outdoors or in a wet or moist location.
- Make sure assembly is done in an appropriate work space away from foot traffic and exposure to bystanders.
- Some components of the machine can be heavy or awkward. Use a second person when doing the assembly steps involving these parts. Do not do steps that involve heavy lifting or awkward movements on your own.
- Set up this machine on a solid, level, horizontal surface.
- Do not try to change the design or functionality of this machine. This could compromise the safety of this machine and will void the warranty.
- If replacement parts are necessary use only genuine replacement parts and hardware supplied by Nautilus. Failure to use genuine replacement parts can cause a risk to users, keep the machine from operating correctly and void the warranty.
- Do not use or put the machine into service until the machine has been fully assembled and inspected for correct performance in accordance with the Manual.
- Read and understand the complete Manual supplied with this machine before first use. Keep the Manual for future reference.
- Do all assembly steps in the sequence given. Incorrect assembly can lead to injury or incorrect function.
- This product contains magnets. Magnetic fields can interfere with the normal use of certain medical devices at a close range. Users may come into proximity of the magnets in the assembly, maintenance, and/or use of the product. Given the obvious importance of these devices, such as a pacemaker, it is important that you consult with your medical provider in connection with the use of this equipment. Please consult the "Safety Warning Labels and Serial Number" section to determine the location of the magnets on this product.

# SAFETY WARNING LABELS AND SERIAL NUMBER

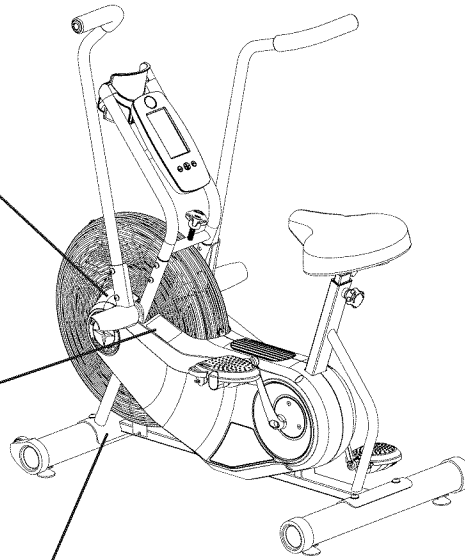
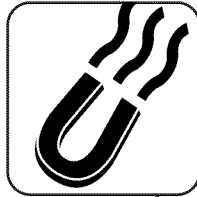

**⚠ WARNING**

- Keep children away.
- Not intended for use by anyone under 14 years of age.
- Prior to use, read and understand the Owner's Manual.
- Injury or death is possible if Caution is not used while using this machine.
- The maximum user weight for this machine is 300 lbs (136 kg).
- Replace any "Caution", "Warning" or "Danger" label that is illegible, damaged, or removed.
- This machine is for home and commercial use.
- When put in a home, lock the machine when not in operation.
- Supervision is required if equipment is used in a commercial environment.

Mfg. Date	Serial Number		
MM/YY	AAAAAABBBPPPPPLCCCCC		
	<b>ISO</b> 20957	<b>FC</b>	<b>CE</b>
18225 NE Riverside Parkway, Portland, Or. 97230			
www.nautilus.com			
Phone: 1-800-NAUTILUS			
Model: Schwinn® AirDyne® AD6 			
Rating: NA			
Class: SA, HA			
Maximum User Weight: 300lb (136kg)			
Fitness Equipment			
Made in: China			
<b>NAUTILUS®</b>		0000 004-6970_B	

<b>Machine Weight:</b>	115 lbs. (52.2 kg)
<b>Power Requirements:</b>	2 AA Batteries (not included)
Operating Voltage:	1.0 - 3.3VDC
<b>Maximum User Weight:</b>	300 lbs. (136 kg)

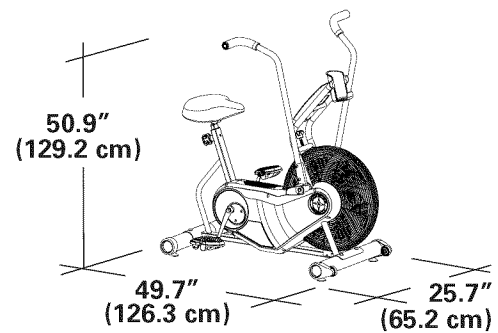
**Regulatory Approvals:**

This product conforms to the applicable EN ISO 20957 International Standards for Stationary Training Equipment, Class S



DO NOT dispose of this product as refuse. This product is to be recycled. For information on the proper method of disposal, contact a Nautilus Customer Service Representative. Contact information is available in the Contacts section in this manual.

**!** This product, its packaging, and components contain chemicals known to the State of California to cause cancer, birth defects, or reproductive harm. This Notice is provided in accordance with California's Proposition 65. If you would like additional information, please refer to our website at [www.nautilus.com/prop65](http://www.nautilus.com/prop65).

**Before Assembly**

Select the area where you are going to set up and operate your machine. For safe operation, the location must be on a hard, level surface. Allow a workout area of a minimum 73.7" (187.2 cm) x 97.7" (248.2 cm).

**Basic Assembly Tips**

Follow these basic points when you assemble your machine:

- Read and understand the "Important Safety Instructions" before assembly.
- Collect all the pieces necessary for each assembly step.
- Using the recommended wrenches, turn the bolts and nuts to the right (clockwise) to tighten, and the left (counterclockwise) to loosen, unless instructed otherwise.
- When attaching 2 pieces, lightly lift and look through the bolt holes to help insert the bolt through the holes.
- The assembly requires 2 people.

# PARTS

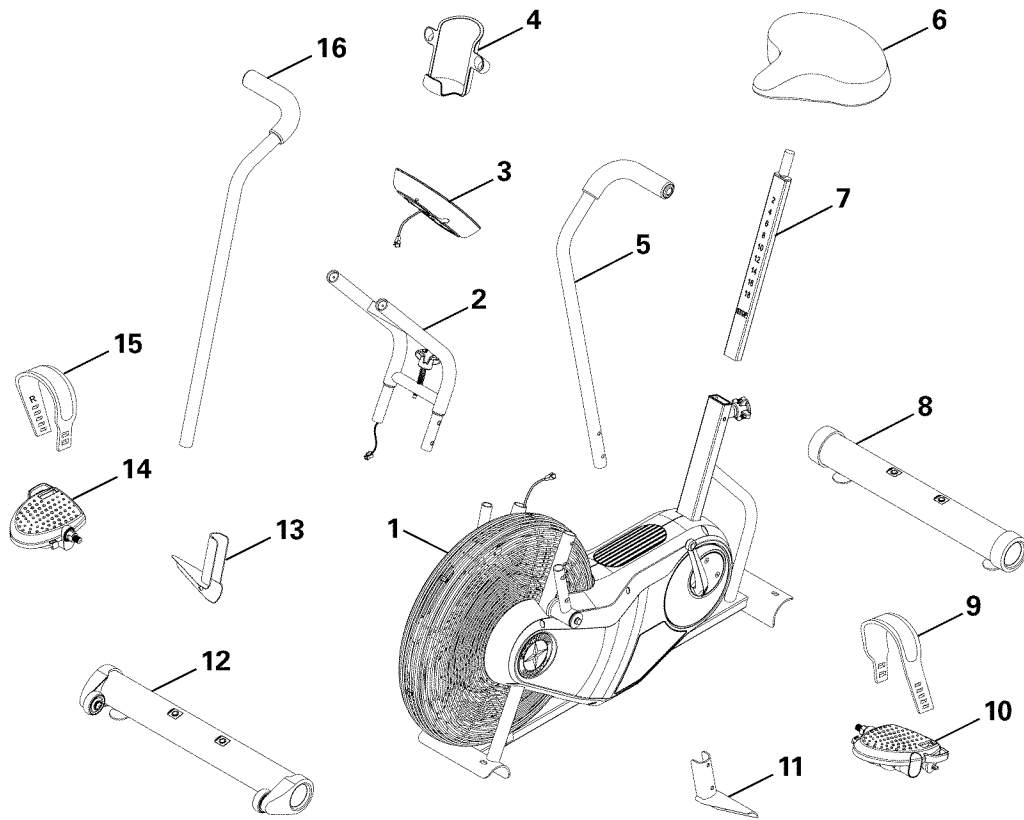

A decal has been applied to all right (" R ") and left (" L ") parts to assist with assembly.

Item	Qty	Description	Item	Qty	Description
1	1	Frame	9	1	Pedal Strap, Left
2	1	Console Support Bar	10	1	Pedal, Left
3	1	Console	11	1	Foot Peg, Left
4	1	Water Bottle Holder	12	1	Stabilizer, Front
5	1	Handlebar, Left	13	1	Foot Peg, Right
6	1	Seat	14	1	Pedal, Right
7	1	Seat Post	15	1	Pedal Strap, Right
8	1	Stabilizer, Rear	16	1	Handlebar, Right

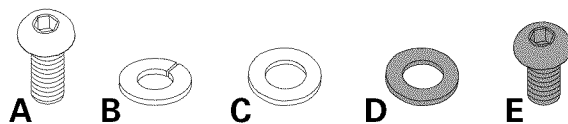

Item	Qty	Description	Item	Qty	Description
A	4	Button Head Hex Screw, M8x1.25x20	D	4	Washer, M8 Black
B	4	Washer, M8 Lock	E	4	Button Head Hex Screw, M8x1.25x12 Black
C	4	Washer, M8			

## Tools

### Included



6 mm



#2  
13 mm  
15 mm  
17 mm

### Not Included



(recommended)

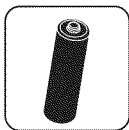

2 AA size batteries (LR6)

## 1. Attach Stabilizers to Frame

Note: Hardware is pre-installed and not on the Hardware Card (\*).

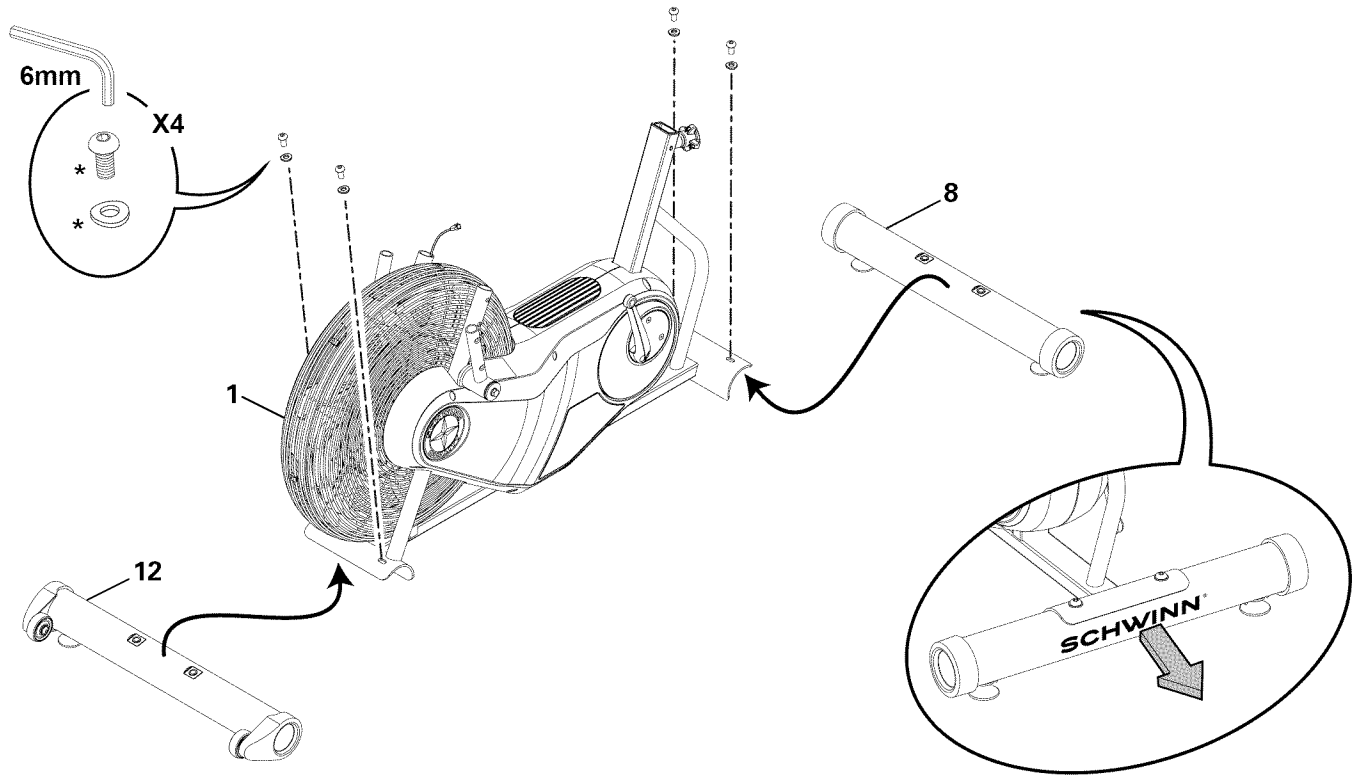

## 2. Attach Pedals and then Pedal Straps to Frame Assembly

Note: The Left Pedal is reverse-threaded. Be sure to attach Pedals on the proper side of the Bike. Orientation is based from a seated position on the bike. The Left Pedal has an "L", the Right Pedal an "R".

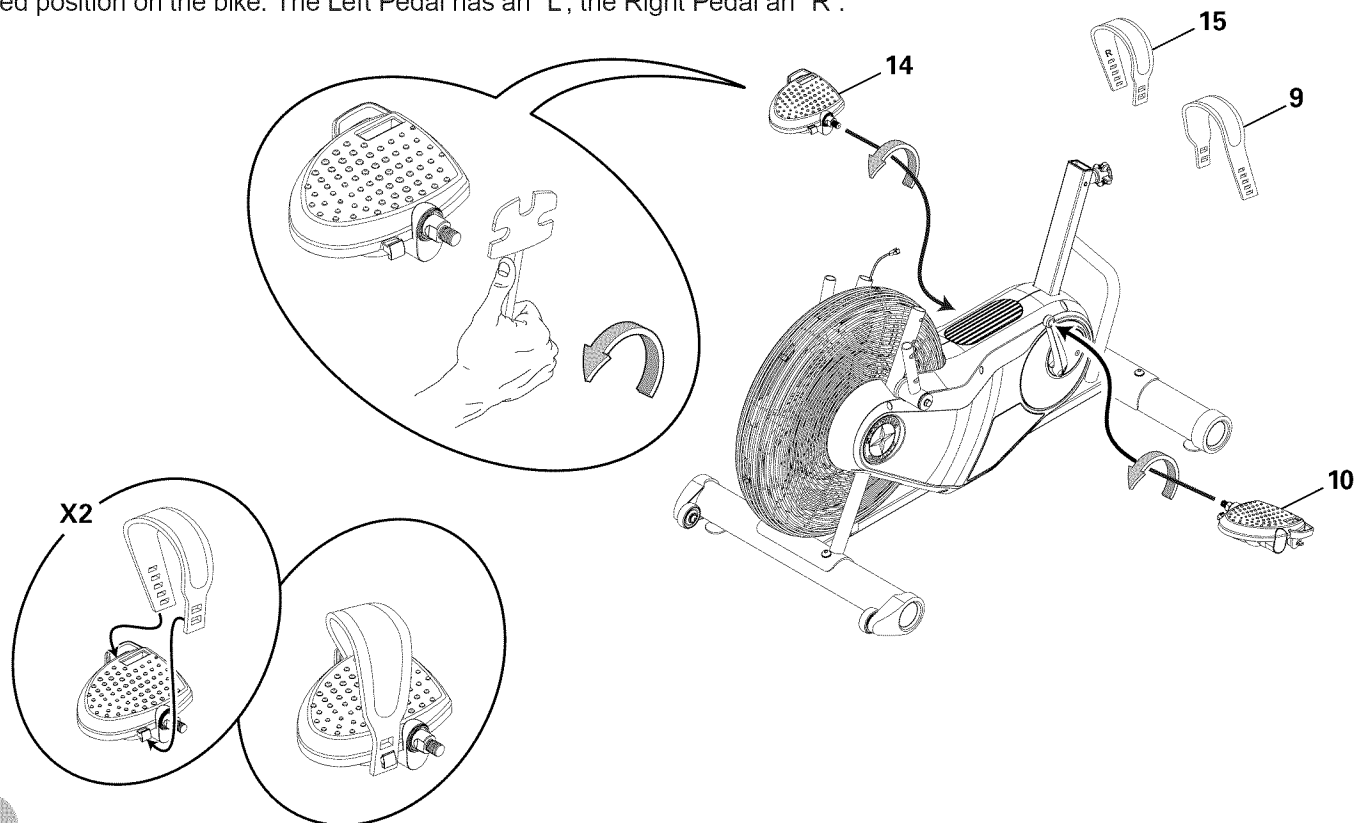



### 3. Connect Cables and Attach the Console Support Bar to Frame Assembly

**Note:** Do not crimp the cables. Pull the lower cable to remove any slack as you insert the Console Support Bar.

**!** In order to avoid possible serious injury, when inserting the tube ends into the Frame Assembly be careful to avoid fingers or hands being caught or pinched.

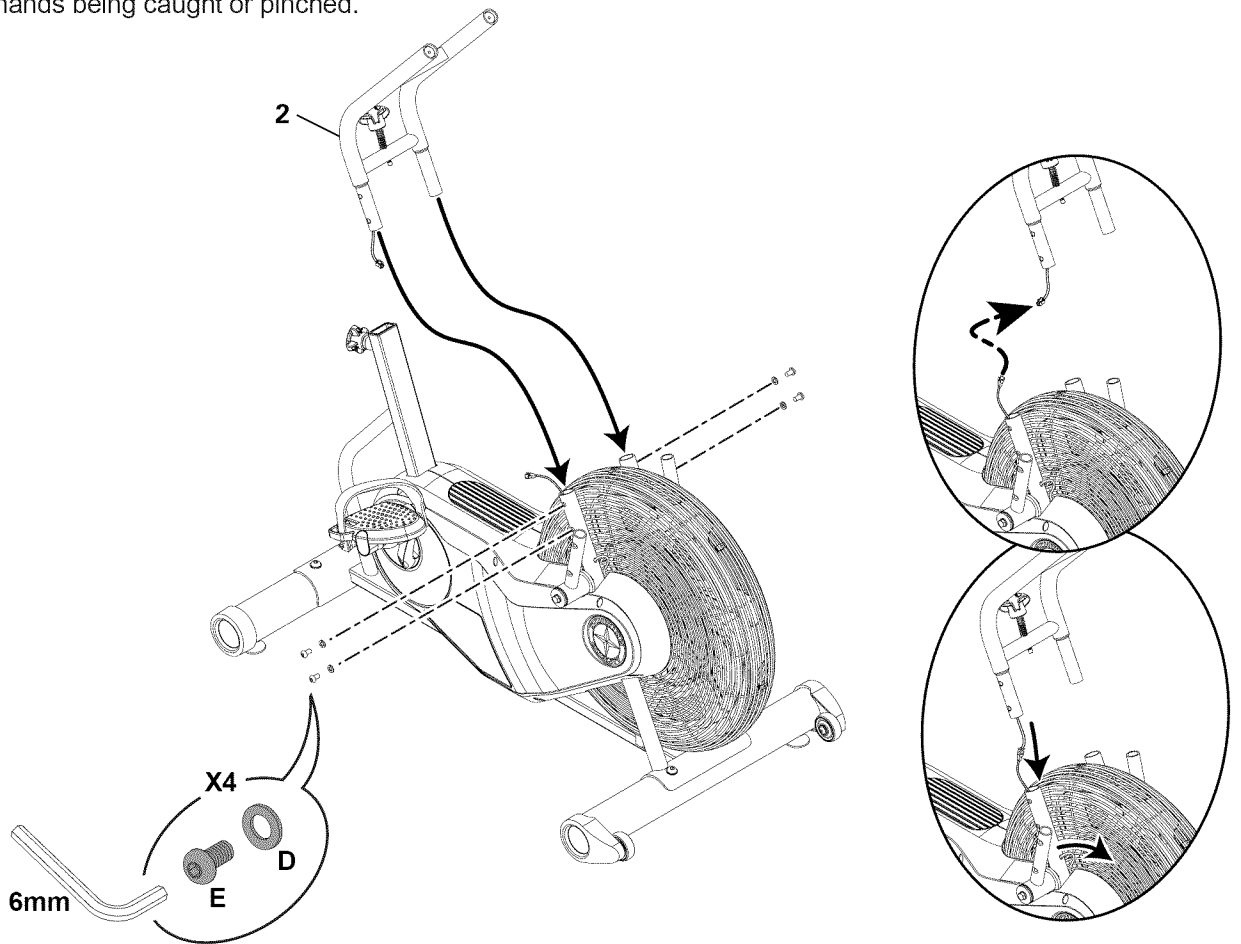

### 4. Remove Hardware and Install Batteries into Console

**Note:** The console uses AA size batteries (LR6), which are not included. Make sure that the batteries point in the direction of the +/- indicators in the battery bay. Hardware is pre-installed and not on the Hardware Card (\*).

**!** Do not mix alkaline, standard (carbon-zinc), or rechargeable (Ni-Cd, Ni-MH, etc) batteries.

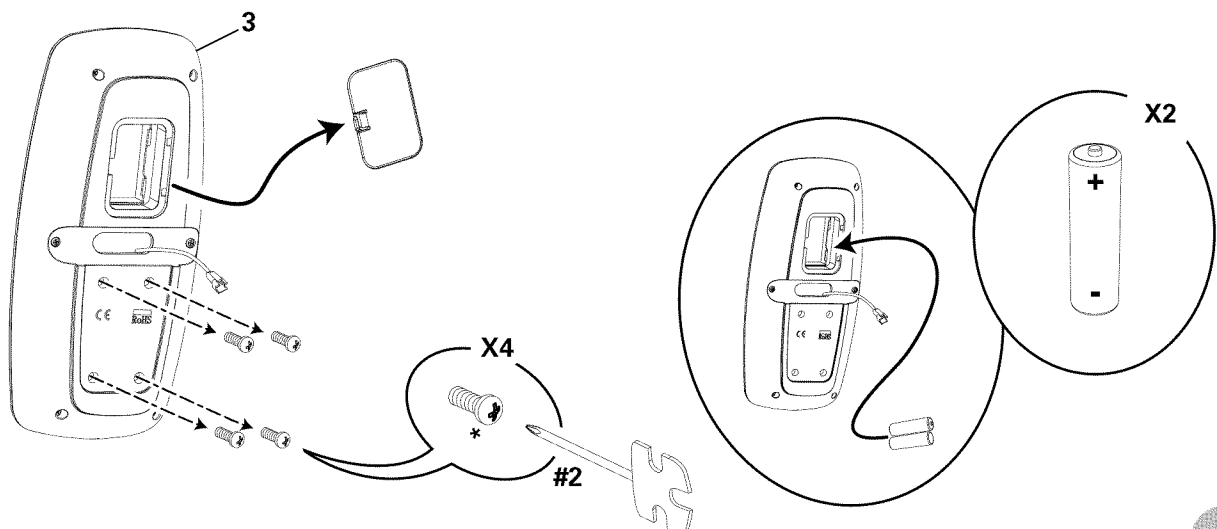

## 5. Connect Cable and Attach the Console

Note: Do not crimp Console Cable.

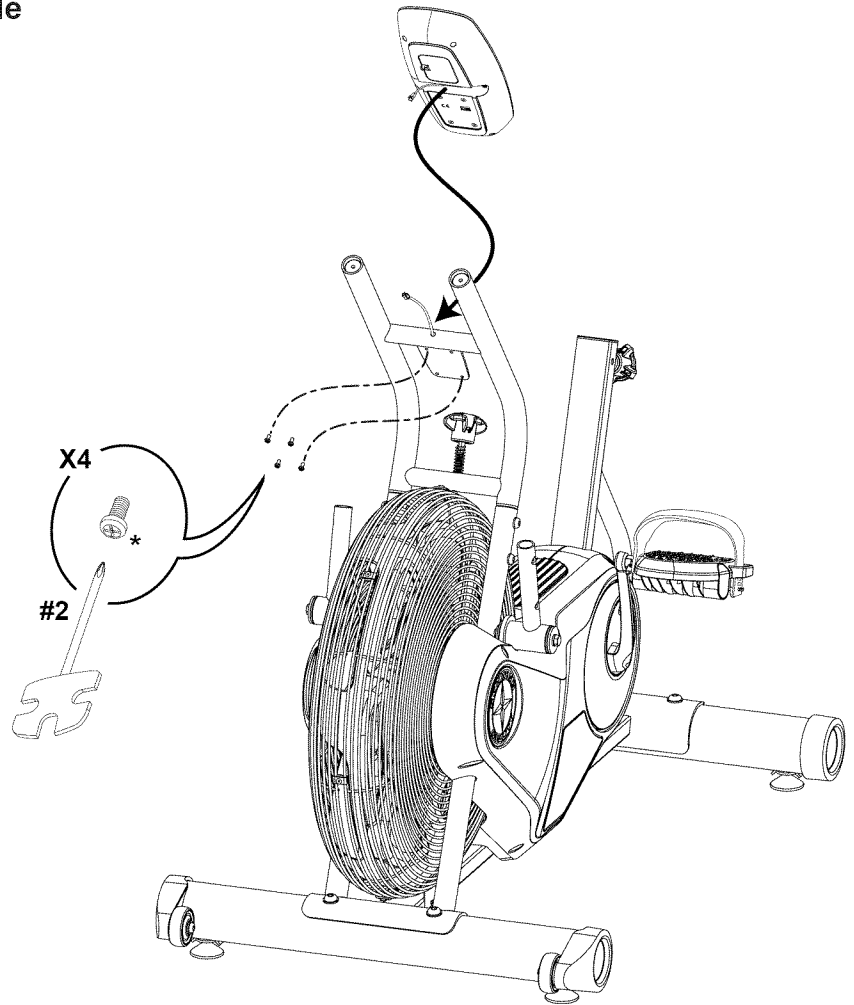
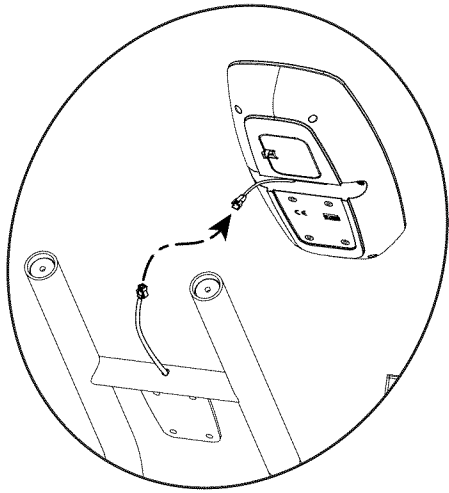

## 6. Attach Water Bottle Holder to Frame Assembly

Note: Hardware is pre-installed and not on the Hardware Card (\*).

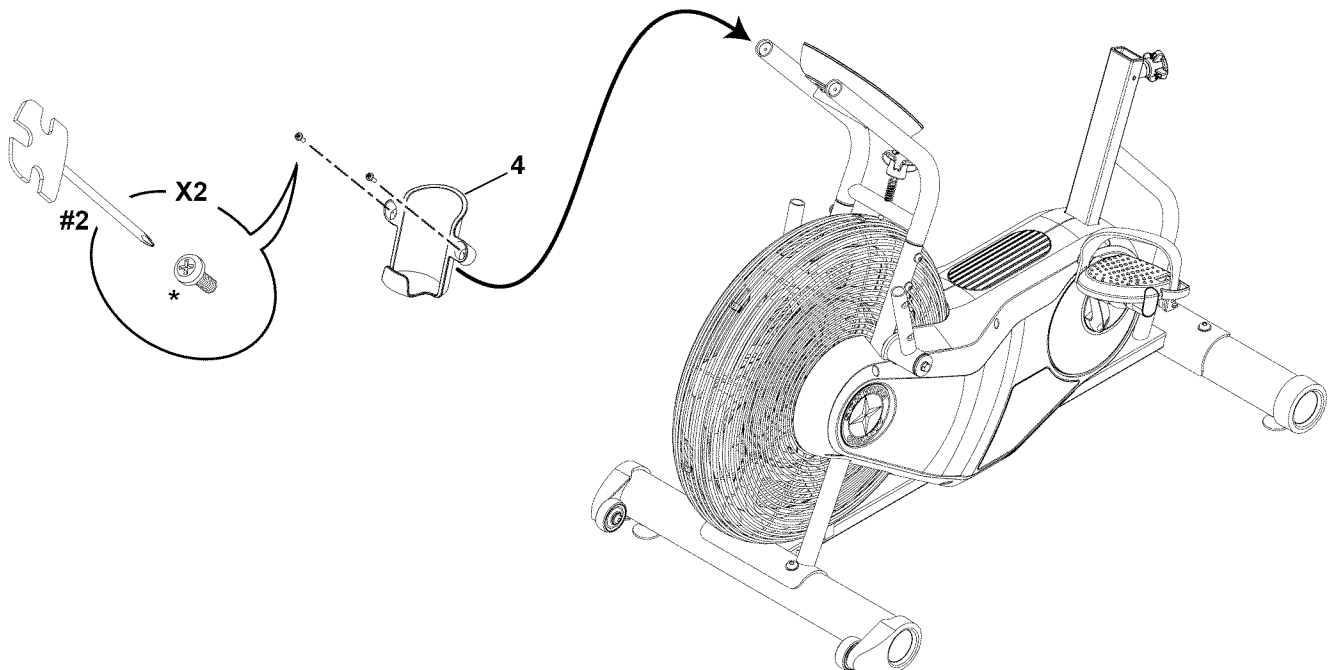

## 7. Attach Foot Pegs and Handlebar Arms to Frame Assembly

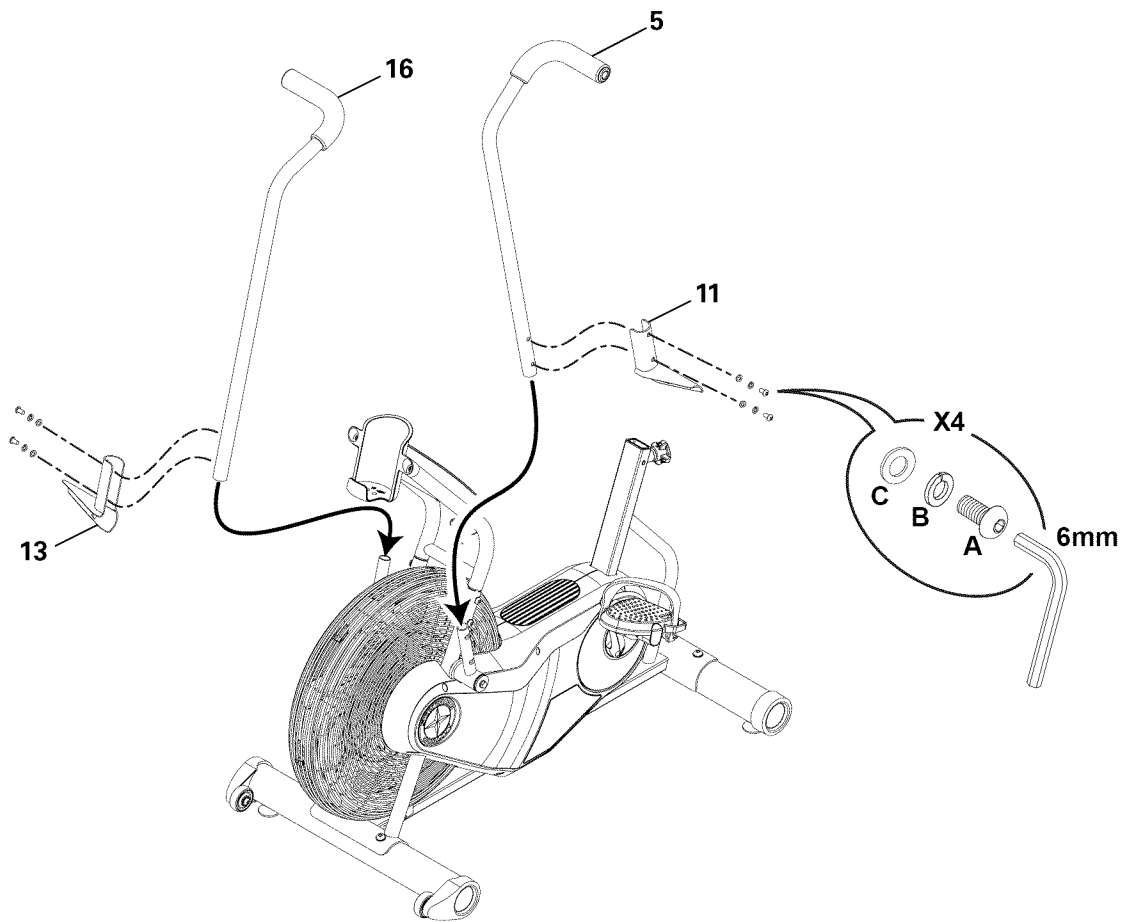

## 8. Loosen and Pull the Seat Post Adjustment Knob to Attach Seat Post to Frame Assembly

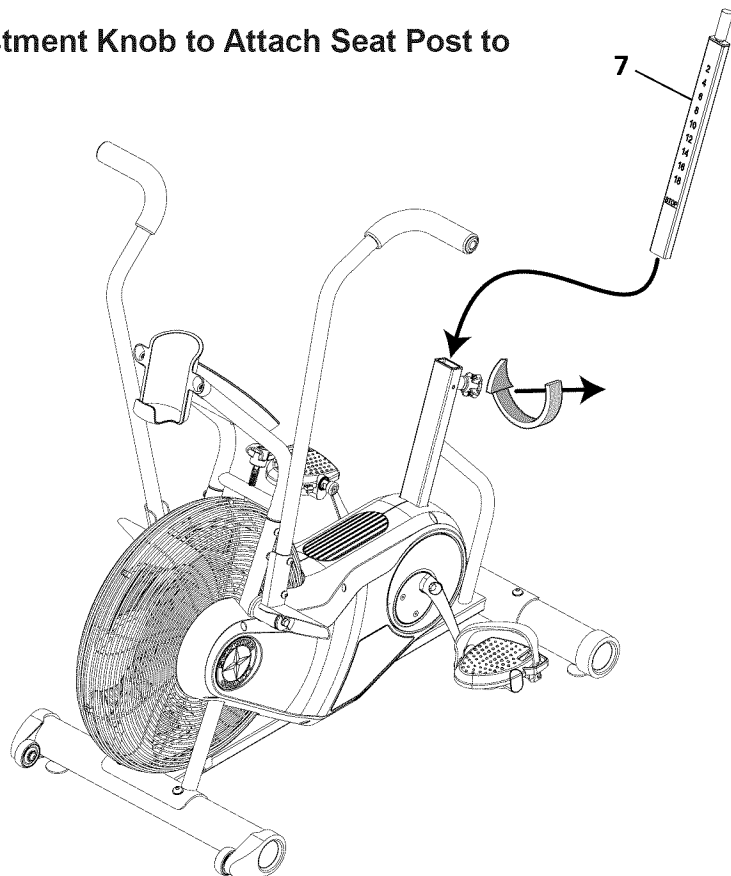

## 9. Attach Seat to Seat Post

**NOTICE:** Be sure the Seat is straight and then tighten the hardware.

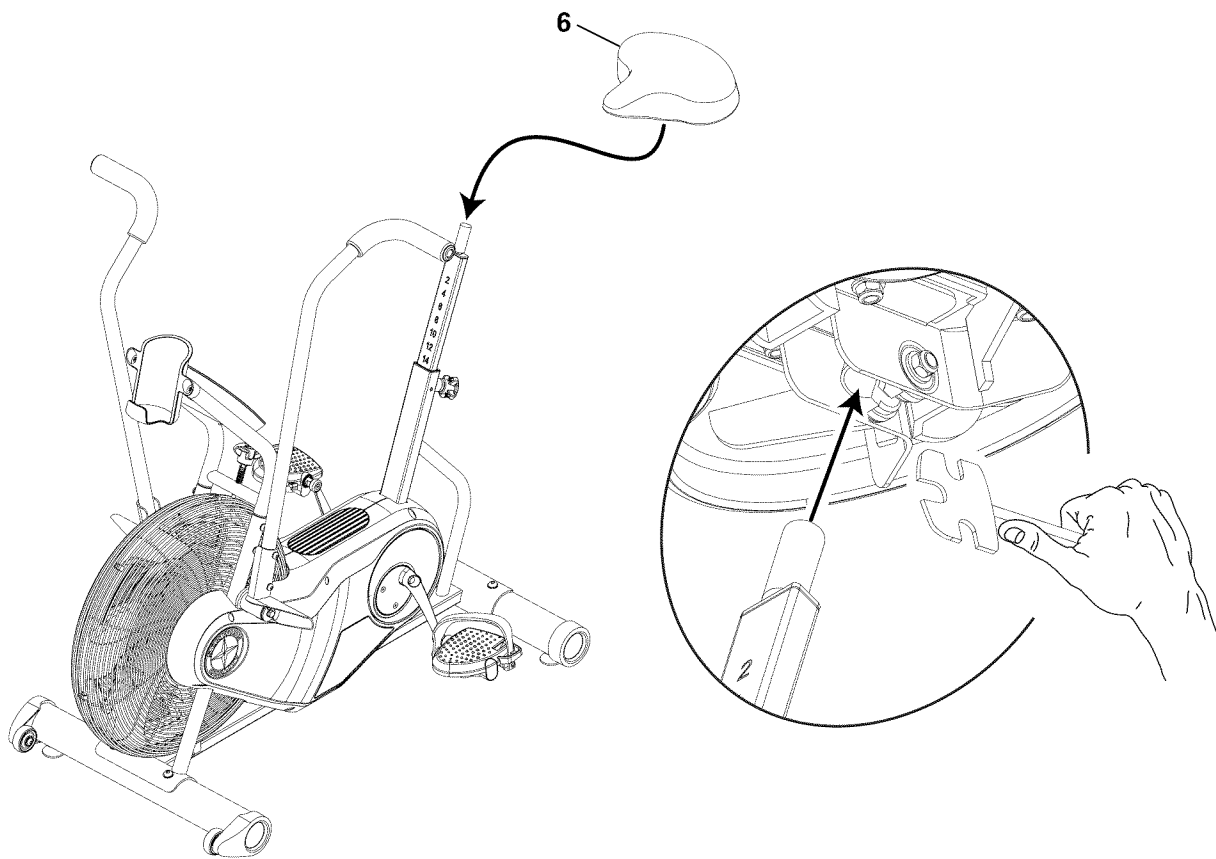

## 10. Final Inspection

Inspect your machine to ensure that all hardware is tight and components are properly assembled.

**!** Do not use or put the machine into service until the machine has been fully assembled and inspected for correct performance in accordance with the Owner's Manual.

## Moving the Machine

**!** The machine may be moved by one or more persons depending on their physical abilities and capacities. Make sure that you and others are all physically fit and able to move the machine safely.

1. Use the Rear Stabilizer to carefully lift the machine onto the transport rollers.

**Note:** Be sure to keep the fan assembly clear of the floor.

2. Push the machine into position.
3. Carefully lower the machine into position.

**NOTICE:** Be careful when you move the machine. All abrupt motions can affect the computer operation.

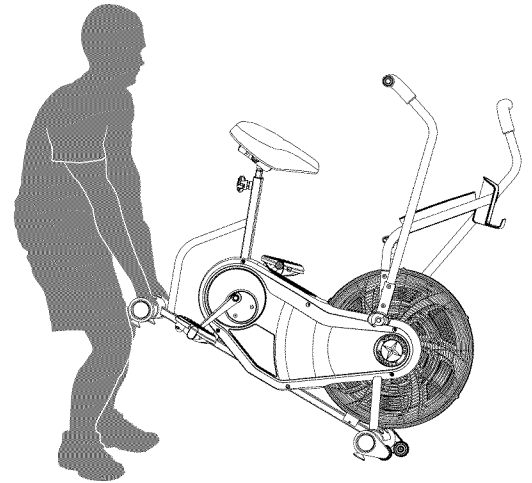

## Leveling the Machine

The machine needs to be leveled if your workout area is uneven. To adjust:

1. Place the machine in your workout area.
2. Loosen the locking nuts and adjust the levelers until they are evenly balanced and in contact with the floor.

**!** Do not adjust the levelers to such a height that they detach or unscrew from the machine. Injury to you or damage to the machine can occur.

3. Tighten the locking nuts.

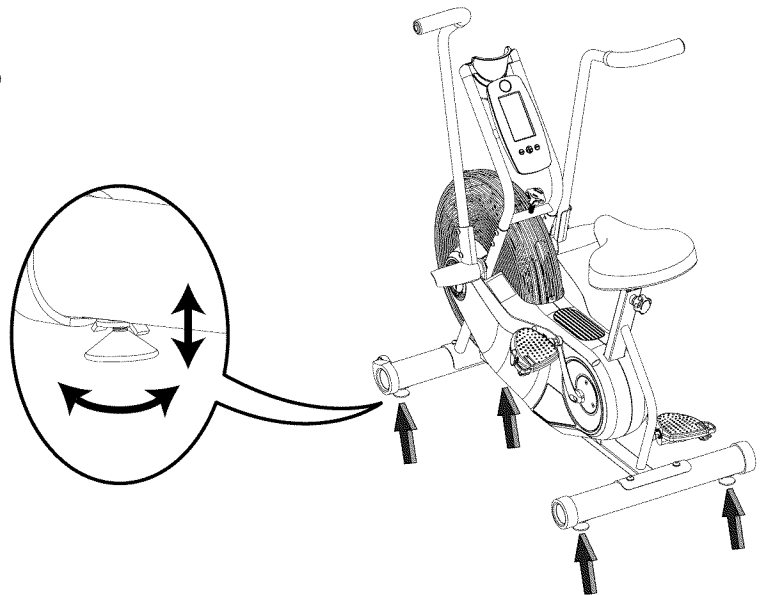

Make sure the machine is level and stable before you exercise.



## IMPORTANT SAFETY INSTRUCTIONS

 This icon means a potentially hazardous situation which, if not avoided, could result in death or serious injury.

### Before using this equipment, obey the following warnings:

 Read and understand the complete Manual. Keep the Manual for future reference.  
 Read and understand all warnings on this machine. If at any time the Warning stickers become loose, unreadable or dislodged, contact Nautilus® Customer Service for replacement stickers.

**⚠ DANGER** To reduce the risk of electrical shock or unsupervised usage of the equipment, always remove the batteries from the machine and wait 5 minutes before cleaning, maintaining or repairing the machine.

- Children must not be let on or near to this machine. Moving parts and other features of the machine can be dangerous to children.
- Not intended for use by anyone under 14 years of age.
- Consult a physician before you start an exercise program. Stop exercising if you feel pain or tightness in your chest, become short of breath, or feel faint. Contact your doctor before you use the machine again. Use the values calculated or measured by the machine's computer for reference purposes only.
- Before each use, examine this machine for loose parts or signs of wear. Do not use if found in this condition. Monitor the Pedals and Crank Arms closely. Contact Nautilus® Customer Service for repair information.
- Maximum user weight limit: 300 lbs. (136 kg). Do not use if you are over this weight.
- Do not wear loose clothing or jewelry. This machine contains moving parts. Do not put fingers or other objects into moving parts of the exercise equipment.
- Set up and operate this machine on a solid, level, horizontal surface.
- Do not step off the machine until the Pedals have fully stopped.
- Make the Pedals stable before you step on them. Use caution when you step on and off the machine.
- Do not operate this machine outdoors or in moist or wet locations.
- Keep at least 24" (0.6 m) on each side of the machine clear. This is the recommended safe distance for access and passage around and emergency dismounts from the machine. Keep third parties out of this space when machine is in use.
- Do not over exert yourself during exercise. Operate the machine in the manner described in this manual.
- Perform all regular and periodic maintenance procedures recommended in the Owner's Manual.
- Correctly adjust and safely engage all Positional Adjustment Devices. Make sure that the Adjustment Devices do not hit the user.
- Keep the Pedals clean and dry.
- Exercise on this machine requires coordination and balance. Be sure to anticipate that changes in speed and resistance level can occur during workouts, and be attentive in order to avoid loss of balance and possible injury.
- Keep batteries away from heat source and hot surfaces.
- Do not drop or put objects into any opening of the machine.
- Do not mix old and new batteries.
- Do not mix alkaline, standard (carbon-zinc), or rechargeable (Ni-Cd, Ni-MH, etc) batteries.
- For safe storage of the machine, remove the batteries and fully tighten the Locking Knob to secure the Resistance Fan. Place the machine in a secure location from children and pets.
- When the machine is put in a studio or club environment, it can only be used in areas where access and control of the machine is managed by approved staff. The degree of management depends on the user's ability to recognize and prevent danger to third parties during the exercise movement.
- This bike cannot stop the Pedals independently of the Resistance Fan. Reduce the pace to slow the Resistance Fan and Pedals to a stop. Do not dismount the bike until the Pedals have come to a complete stop.

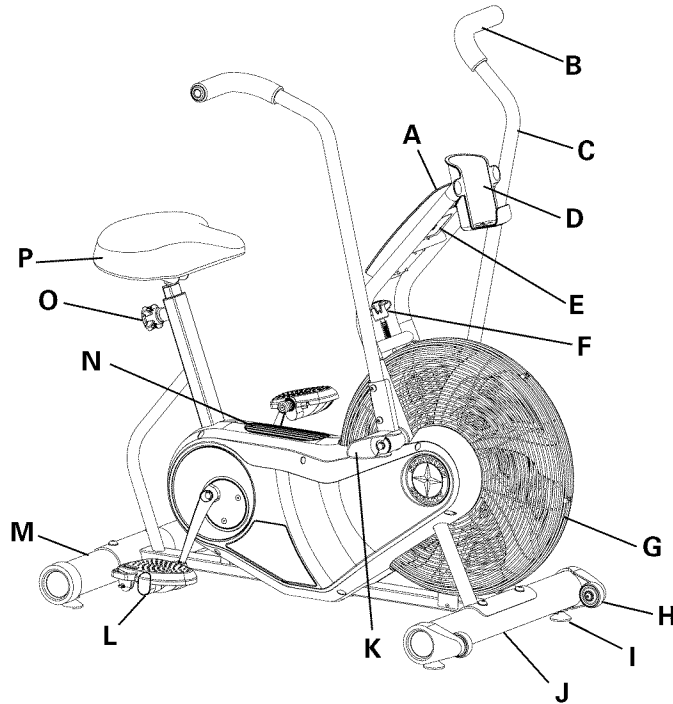

A	Console	G	Air Resistance Fan	M	Stabilizer, Rear
B	Hand Grip	H	Transport Roller	N	Foot Step Pad
C	Handlebar	I	Leveler	O	Seat Post Adjustment Knob
D	Water Bottle Holder	J	Stabilizer, Front	P	Seat
E	Battery Compartment	K	Foot Peg		
F	Locking Knob	L	Pedal		

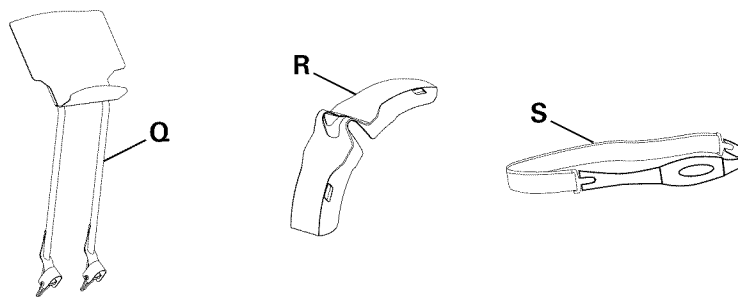

**Accessories**

Q	AirDyne® Reading Rack	R	AirDyne® Wind Screen	S	Remote Heart Rate Chest Strap
---	-----------------------	---	----------------------	---	-------------------------------

To order, go to [www.schwinnfitness.com](http://www.schwinnfitness.com) or call 1 (800) 605-3369.

## Console Features

The Console provides information about your workout on the display screen.

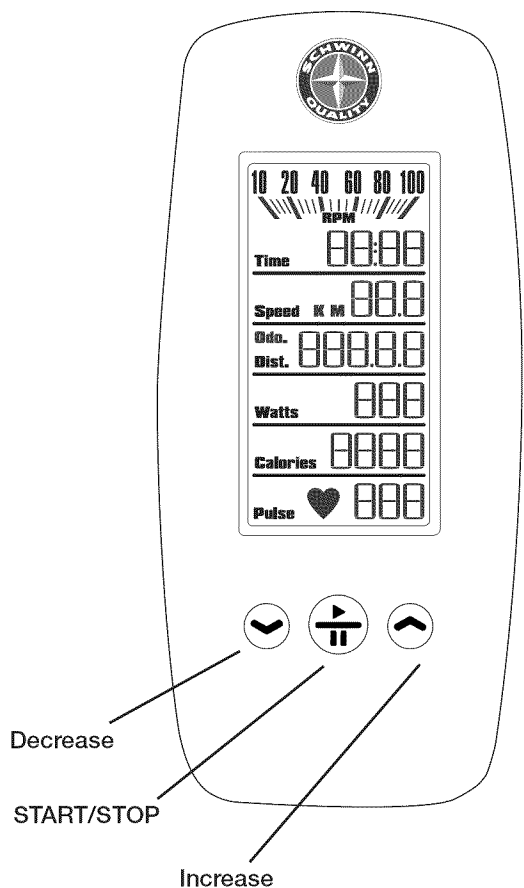

### LCD Display Data

The console display shows each workout value.

#### RPM

The RPM display field shows the machine revolutions per minute (RPM). The maximum display is 100.

#### Time

The TIME display field shows the time count of the workout. The maximum display is 99:59. If the time count is more, the display starts again at 0:00.

During the initial power-up, this display will show altitude ( "Alt" ). The altitude where the machine will be in operation must be entered.

#### Speed

The SPEED display field shows the machine speed in kilometers per hour ( "KM" ) or miles per hour ( "M" ), to one decimal place—for example, 3.4 or 10.5. The maximum display is 99.9.

#### Dist.

The DISTANCE display field shows the distance count (miles or km) in the workout, to two decimal places—for example, 2.07. The maximum display is 99.99. If the distance exceeds 99.99, the display starts again at 0.00.

**Note:** To change the measurement units to English Imperial or metric, refer to the "Console Service Mode" section in this manual.

The Odometer ( "Odo." ) shows the sum of all workout distances. It is displayed when a workout is paused, or as an option in the "Console Service Mode".

During the initial power-up, this display will show the Altitude value until accepted.

#### Watts

The WATTS display field shows the power that you are producing at the current resistance level (1 horsepower = 746 watts).

#### Calories

The CALORIES display field shows the estimated calories that you have burned during the exercise. The maximum display is 9999. If the calorie count is more, the display flashes 9999.

#### Pulse

The PULSE display shows the heart rate in beats per minute (BPM) from a telemetric heart rate sensor. The icon will flash when it has a signal from a telemetric heart rate strap. This display value will be blank if a heart rate signal is not detected.

**!** Consult a physician before you start an exercise program. Stop exercising if you feel pain or tightness in your chest, become short of breath, or feel faint. Contact your doctor before you use the machine again. Use the values calculated or measured by the machine's computer for reference purposes only.

## Keypad Functions

Decrease (▼) button- Decreases a value (time or altitude) or moves through options



START/STOP button- Starts a Program workout, confirms a selection, and ends a paused workout if held down for 3 seconds.

Increase (▲) button- Increases a value (time or altitude) or moves through options

### Remote Heart Rate Monitor

Monitoring your Heart Rate is one of the best procedures to control the intensity of your exercise. The Console can read telemetry HR signals from a Heart Rate Chest Strap Transmitter that operates in the 4.5kHz - 5.5kHz range.

**Note:** The heart rate chest strap must be an uncoded heart rate strap from Polar Electro or an uncoded POLAR® compatible model. (Coded POLAR® heart rate straps such as POLAR® OwnCode® chest straps will not work with this equipment.)

**!** If you have a pacemaker or other implanted electronic device, consult your doctor before using a wireless chest strap or other telemetric heart rate monitor.

### Heart Rate Calculations

Your maximum heart rate usually decreases from 220 Beats Per Minute (BPM) in childhood to approximately 160 BPM by age 60. This fall in heart rate is usually linear, decreasing by approximately one BPM for each year. There is no indication that training influences the decrease in maximum heart rate. Individuals of the same age could have different maximum heart rates. It is more accurate to find this value by completing a stress test than by using an age related formula.

Your at-rest heart rate is influenced by endurance training. The typical adult has an at-rest heart rate of approximately 72 BPM, where as highly trained runners may have readings of 40 BPM or lower.

The Heart Rate table is an estimate of what Heart Rate Zone (HRZ) is effective to burn fat and improve your cardiovascular system. Physical conditions vary, therefore your individual HRZ could be several beats higher or lower than what is shown.

The most efficient procedure to burn fat during exercise is to start at a slow pace and gradually increase your intensity until your heart rate reaches between 60 – 85% of your maximum heart rate. Continue at that pace, keeping your heart rate in that target zone for over 20 minutes. The longer you maintain your target heart rate, the more fat your body will burn.

The graph is a brief guideline, describing the generally suggested target heart rates based on age. As noted above, your optimal target rate may be higher or lower. Consult your physician for your individual target heart rate zone.

**Note:** As with all exercises and fitness regimens, always use your best judgment when you increase your exercise time or intensity.

**FAT-BURNING TARGET HEART RATE**

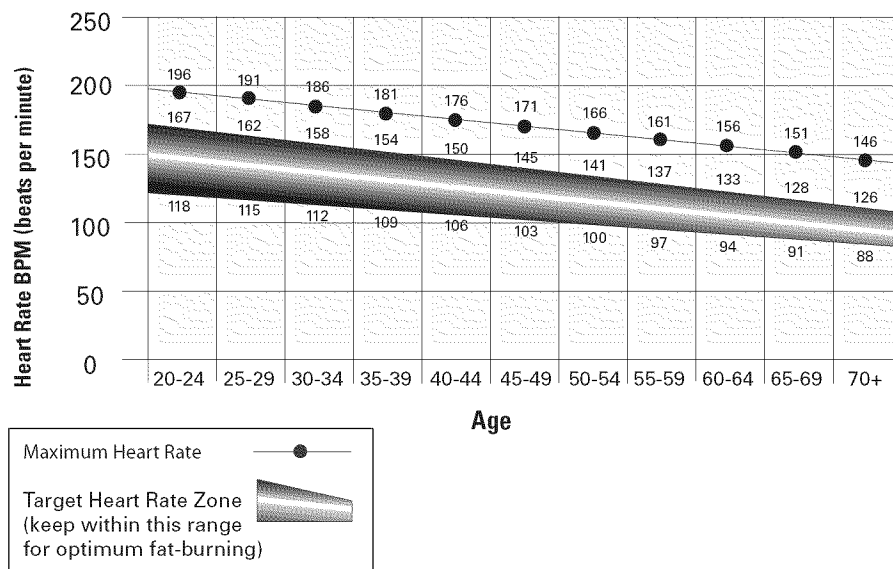

## What to Wear

Wear rubber-soled athletic shoes. You will need the appropriate clothes for exercise that allow you to move freely.

## How Often Should You Exercise

**!** Consult a physician before you start an exercise program. Stop exercising if you feel pain or tightness in your chest, become short of breath, or feel faint. Contact your doctor before you use the machine again. Use the values calculated or measured by the machine's computer for reference purposes only.

- 3 times a week for 20 minutes each day.
- Schedule workouts in advance and try to follow the schedule.

## Seat Adjustment

Correct seat placement encourages exercise efficiency and comfort, while reducing the risk of injury.

1. With a Pedal in the forward position, place the heel of your foot to the lowest part of it. Your leg should be bent slightly at the knee.
2. If your leg is too straight or your foot cannot touch the Pedal, you need to move the seat downward. If your leg is bent too much, you need to move the seat upward.

**!** Step off the machine before you adjust the seat.

3. Loosen and pull the Seat Post Adjustment Knob on the Seat Post. Adjust the seat to the desired height.

**!** Do not lift the Seat post above the "STOP" mark on the Seat Post.

4. Release the Seat Post Adjustment Knob to engage the locking pin. Be sure that the pin is fully engaged and fully tighten the adjustment knob.

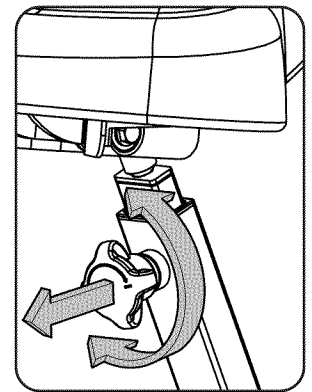

## Foot Position / Pedal Strap Adjustment

Foot pedals with straps provide secure footing to the exercise bike.

1. Rotate the Pedals until one can be reached.

**!** Be aware that the Pedals, Handlebars and Resistance Fan are connected and when any of these parts move the others do as well.

2. Put the ball of each foot on the Pedals.
3. Fasten the strap over the shoe.
4. Repeat for the other foot.

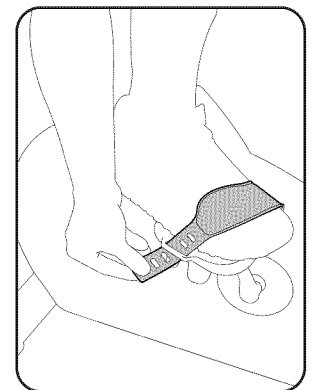

Be sure toes and knees point directly forward to ensure maximum Pedal efficiency. Pedal straps can be left in position for subsequent workouts.

## Using the Machine

**!** Be aware that the Pedals, Handlebars and Resistance Fan are connected and when any of these parts move the others do as well.

Carefully mount the machine using the Foot Step Pad if necessary. Adjust the Seat and Pedals before starting a workout.

Lower Body Workout: Slowly pedal with your arms relaxed at your sides or with your hands resting on the Hand Grips as the Handlebars move.

**Full Body Workout:** Grasp the Hand Grips with your palms down. Push and pull the Handlebars as you pedal, keeping your elbows low and next to your body.

**Upper Body Workout:** Grasp the Hand Grips firmly with palms down and place your feet on the Foot Pegs. Lean slightly forward at the hips with your back straight and shoulders down. Now push and pull the Handlebars

**Note:** You may need to safely push a Pedal to assist with starting the workout.

To increase the air resistance and workload, increase your level of activity. To exercise all the muscle groups in your arms, alter your grasp to palms up for part of the workout.

When done with your workout, reduce the Resistance Fan speed until the machine fully stops.

**!** This bike cannot stop the Pedals independently of the Resistance Fan. Reduce the pace to slow the Resistance Fan and Pedals to a stop. Do not dismount the bike until the Pedals have come to a complete stop.

### Locking the Fan Assembly / Storage

When the machine is not in use, be sure to lock the Fan Assembly with the Locking Pin. The fan assembly should be locked for storage of the machine.

**!** For safe storage of the machine, remove the batteries and engage the Locking Pin to secure the Resistance Fan. Place the machine in a secure location from children and pets. Be aware that the Pedals, Handlebars and Resistance Fan are connected and when any of these parts move the others do as well.

To lock the Fan Assembly:

1. Be sure the Locking Pin is between the ends of the fan blades.

**Note:** The Locking Pin will not engage on the end of a fan blade, and may damage the fan blade if attempted.

2. Push down and turn the Locking Pin a full 90 degrees.

To disengage the Locking Pin:

1. Turn a full 90 degrees and release the Locking Pin. The Locking Pin will release from the Fan Assembly.

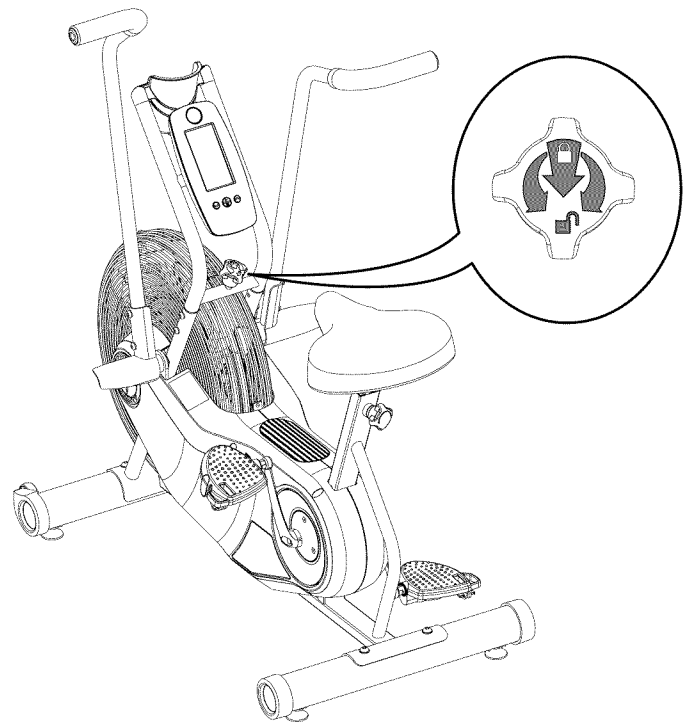

### Power-Up / Idle Mode

The Console will enter Power-Up / Idle Mode if any button is pushed, or if it receives a signal from the RPM sensor as a result of pedaling the machine.

**Note:** The Console will display "Lbatt" if the batteries are around 10% of their rated power during power up.

### Auto Shut-Off (Sleep Mode)

If the Console does not receive any input in approximately 5 minutes, it will automatically shut off. The LCD display is off while in Sleep Mode.

**Note:** The Console does not have an On/Off switch.

## Initial Setup

During the initial power-up, the Console will display “Alt” and must be setup with the current workout altitude.

1. Push the Increase/Decrease buttons to change the value for the altitude. Entering the correct value will make the calorie count more accurate.
2. Push the START/STOP button to set.

**Note:** The altitude value can be adjusted at a future time. To adjust the value, consult the “Console Set-Up Mode” section.

## Quick Start Workout

The Quick Start program lets you start a workout without entering any information.

1. Sit on the machine.
2. With the Console in Idle Mode, push the START/STOP button to start the workout program.
3. When done with your workout, stop pedaling. Then push and hold down the START/STOP button for 3 seconds to end the workout.

## Custom Time Workout

The Console allows you to select a Custom Time Workout and enter your own time value. The Console will remember this value until changed.

1. Sit on the machine.
2. With the Console in Idle Mode, push and hold down for 3 seconds the START/STOP button.
3. The Console will show the default value or the last custom time value.

**Note:** The default time value is 20 minutes.

4. Push the Increase and Decrease buttons to adjust the custom time value.
5. Push START/STOP to accept the custom time workout. Your Custom Goal Workout will now begin.

## Pausing or Stopping

To Pause a workout:

1. Stop pedaling to pause your workout.

**Note:** The Console will automatically pause if there is no RPM signal for 5 seconds.

2. To continue your workout, push START/STOP or start pedaling.

To stop the workout, push and hold down the START/STOP button for 3 seconds. The Console will go into Results mode.

When paused, the Console display will flash the current workout values of TIME, AVERAGE SPEED, DISTANCE, TOTAL MACHINE DISTANCE (“Odo.”), WATTS, CALORIES, and AVERAGE HEART RATE (if activated).

## Results Mode

When you complete or end a workout, the Console will display your workout values three times in the order of TIME, AVERAGE SPEED, DISTANCE, WATTS, CALORIES, and AVERAGE HEART RATE (if activated).

Push START/STOP to stop the Results display and go back to Idle Mode.

The Console Service Mode lets you set the units of measurement to either English or Metric, see the total time and distance the machine has been used, adjust the altitude value for a more accurate calorie count, or find out which version of Firmware is installed.

1. Hold down the Increase button and Decrease button together for 3 seconds while in the Idle Mode to go into the Console Service Mode.
2. The Console display shows the Units prompt ( "Unit" ). Push START/STOP to start Units option. Push the Increase/Decrease buttons to change between "M" (Imperial English units) and "KM" (metric units).
3. Push START/STOP to set. For the next option, push the Increase button.
4. The Console display shows the Workout Statistics prompt ( "StAt" ). Push START/STOP to start the Workout Statistics option. The Console will display the Total Distance ( "Odo" ) and Total Time.  
**Note:** The upper displayed value is total hours followed by the remaining minutes.
5. Push START/STOP to exit. For the next option, push the Increase button.
6. The Console display shows the Firmware Version prompt ( "Fir" ). The Console will display which Firmware Version is installed in the Speed display field.
7. For the next option, push the Increase button.
8. The Console display shows Altitude ( "Alt" ) with the previously entered value in the Speed display field. Push START/STOP to adjust the Altitude value. Use the Increase/Decrease buttons to change the value.
9. Push START/STOP to exit. For the next option, push the Increase button.
10. The Console display shows the exit prompt ( "dOnE" ).
11. Push START/STOP to exit.

To fully exit the Console Service Mode push and hold down the START/STOP button for 3 seconds. In Service Mode if the Console does not receive any input in approximately 5 minutes, it goes into Sleep Mode.

## MAINTENANCE

Read all maintenance instructions fully before you start any repair work. In some conditions, an assistant is required to do the necessary tasks.

 Equipment must be regularly examined for damage and repairs. The owner is responsible to make sure that regular maintenance is done. Worn or damaged components must be repaired or replaced immediately. Only manufacturer supplied components can be used to maintain and repair the equipment.

**⚠ DANGER** To reduce the risk of electrical shock or unsupervised usage of the equipment, always remove the batteries from the machine and wait 5 minutes before cleaning, maintaining or repairing the machine.

**Daily:** Before each use, examine the exercise machine for loose, broken, damaged, or worn parts. Do not use if found in this condition. Repair or replace all parts at the first sign of wear or damage. After each workout, use a damp cloth to wipe your machine and Console free of sweat.

**Note:** Avoid excessive moisture on the Console.

**Weekly:** Clean the machine to remove any dust, dirt, or grime from the surfaces.  
Check for smooth seat operation. If needed, sparingly apply a thin coating of silicone lube to ease operation.

**Note:** Do not use petroleum based products.

**Monthly or after 20 hours:** Check pedals, crank arms and handlebars. Make sure all bolts and screws are tight. Tighten as necessary.

**NOTICE:** Do not clean with a petroleum based solvent or an automotive cleaner. Be sure to keep the Console free of moisture.

 When the machine is used in a club or studio environment the Pedals must be replaced every year to maintain maximum user safety and performance. Only use replacement Pedals available from Nautilus. Other brands of Pedals may not be designed for Indoor Cycling and can cause danger to users and bystanders.

## Replacing the Console Batteries

The Console will display “Lbatt” for ten seconds when the batteries are around 10% of their rated power during power up. When replacing the batteries, make sure the batteries point in the +/- direction shown in the battery bay.

**Note:** The console uses AA size batteries (LR6).



Do not mix old and new batteries.

Do not mix alkaline, standard (carbon-zinc), or rechargeable (Ni-Cd, Ni-MH, etc) batteries.

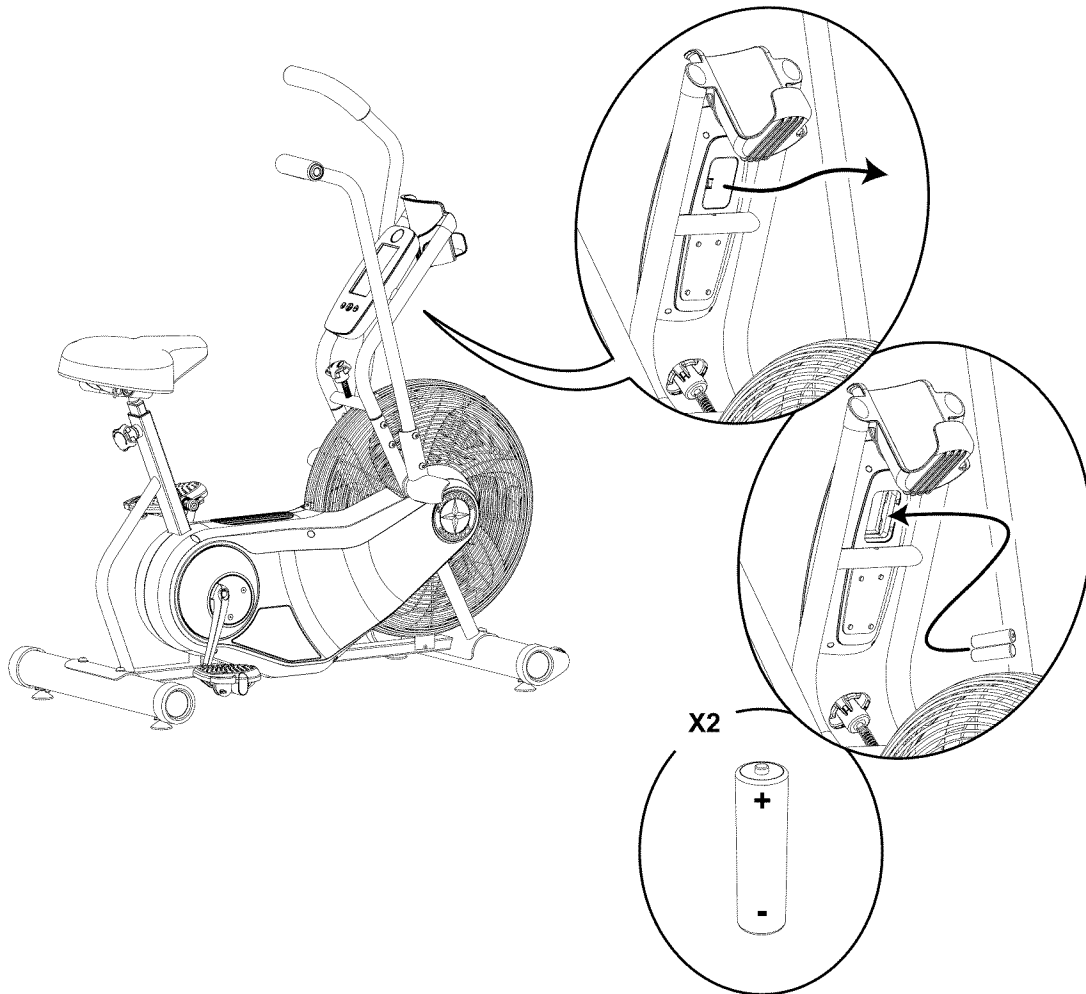

## Maintenance Parts

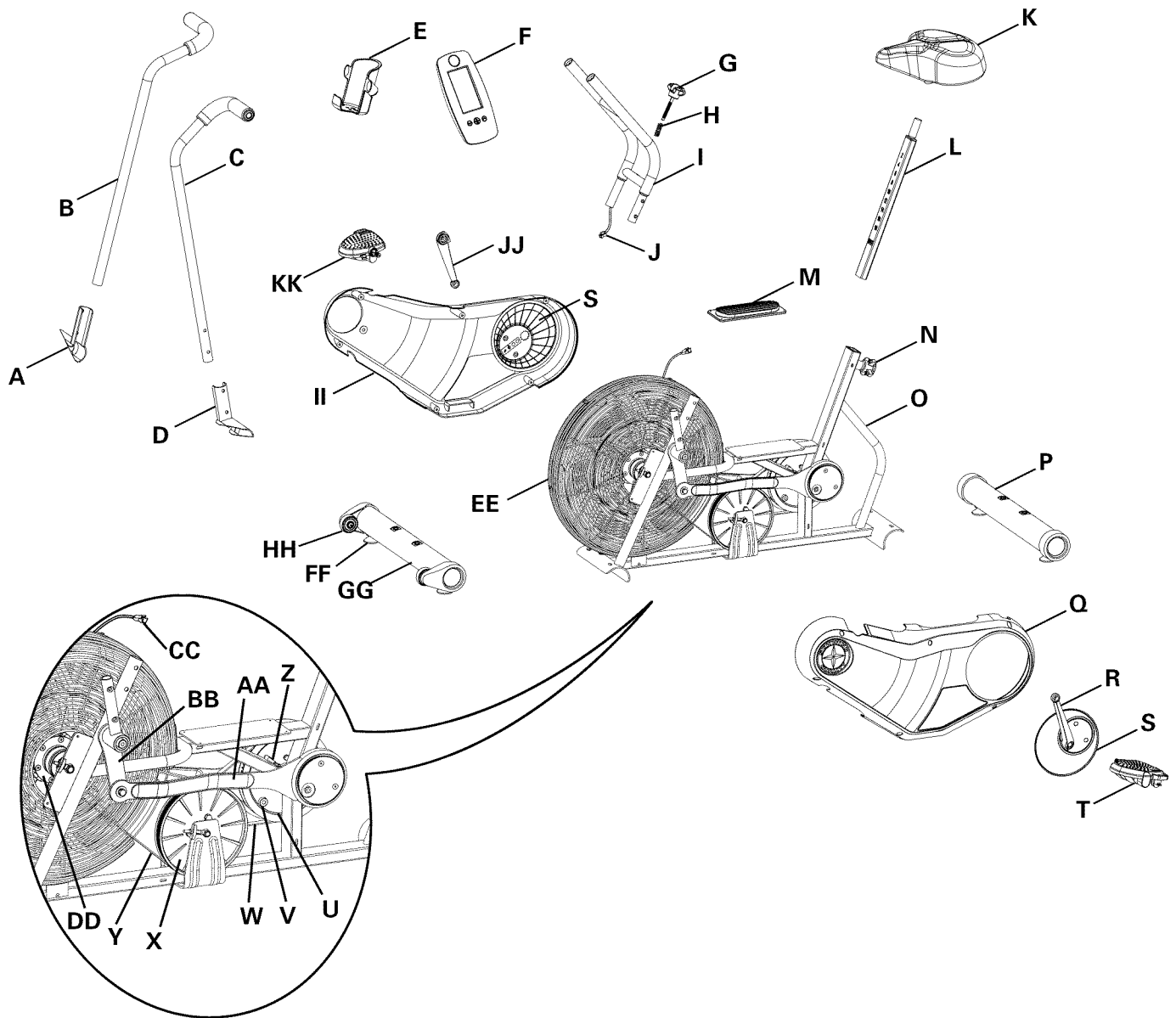

A	Foot Peg, Right	N	Seat Adjustment Knob	AA	Connector Arm
B	Handlebar, Right	O	Frame	BB	Arm Pivot
C	Handlebar, Left	P	Stabilizer, Rear	CC	Console Cable, Lower
D	Foot Peg, Left	Q	Shroud, Left	DD	Resistance Fan Assembly
E	Water Bottle Holder	R	Crank Arm, Left	EE	Fan Cover
F	Console	S	Center Plate	FF	Leveler
G	Locking Knob	T	Pedal, Left	GG	Stabilizer, Front
H	Spring, Knob	U	Pulley, Crank	HH	Transport Wheel
I	Console Cable, Upper	V	Speed Sensor Magnet	II	Shroud, Right
J	Console Support Bar	W	Crank Belt	JJ	Crank Arm, Right
K	Seat	X	Pulley, Drive	KK	Pedal, Right
L	Seat Post	Y	Drive Belt		
M	Foot Step Pad	Z	Speed Sensor Assembly		



Condition/Problem	Things to Check	Solution
Console will not power up/turn on/start	Batteries	Make sure batteries are installed correctly. If batteries are correctly installed, replace with a set of new batteries.
	Check data cable integrity	All wires in cable should be intact. If any are visibly crimped or cut, replace cable.
	Check data cable connections/orientation	Make sure cable is connected securely and oriented properly. Small latch on connector should line up and snap into place.
	Check console display for damage	Check for visual sign that console display is cracked or otherwise damaged. Replace Console if damaged.
		If the above steps do not resolve the problem, contact Customer Care for further assistance.
Speed displayed is not accurate	Display set to wrong unit of measure. (English/Metric)	Change display units (consult "Console Service Mode")
Speed displayed is always "0"/stuck in Pause mode	Data cable	Make sure the data cable is connected to the back of the Console and the main frame assembly.
	Speed Sensor (under Shrouds)	Make sure the Speed Sensor Magnet and the Speed Sensor are in place.
No speed/RPM reading	Check data cable integrity	All wires in cable should be intact. If any are cut or crimped, replace cable.
	Check data cable connections/orientation	Be sure cable is connected securely and oriented properly. Small latch on connector should line up and snap into place.
	Check Speed Sensor Magnet position (requires shroud removal)	Magnet should be in place on pulley.
	Check Speed Sensor Assembly (requires shroud removal)	Speed Sensor Assembly should be aligned with magnet and connected to data cable. Realign sensor if necessary. Replace if there is any damage to the sensor or the connecting wire.
Console displays "Lbatt" error code	Batteries	Replace batteries
Unit operates but Tele-metric Heart Rate not displayed	Chest Strap (optional)	Strap should be "POLAR®" compatible and uncoded. Make sure strap is directly against skin and contact area is wet.
	Interference	Try moving unit away from sources of interference (TV, Microwave, etc).
	Replace Chest Strap	If interference is eliminated and HR does not function, replace strap.
	Replace Console	If HR still does not function, replace Console.
Console shuts off (enters sleep mode) while in use	Check data cable integrity	All wires in the cable should be intact. If any are cut or crimped, replace cable.
	Check data cable connections/orientation	Be sure cable is connected securely and oriented properly. Small latch on connector should line up and snap into place.
	Check Speed Sensor Magnet position (requires shroud removal)	Speed Sensor Magnet should be in place on pulley.
	Check Speed Sensor Assembly	Contact Customer Care for further assistance.

Unit rocks/does not sit level	Check leveler adjustment	Leveling feet may be turned in or out to level bike.
	Check surface under unit	Adjustment may not be able to compensate for extremely uneven surfaces. Move bike to level area.
Pedals loose/unit difficult to pedal	Check pedal to crank connection	Pedal should be tightened securely to crank. Be sure connection is not cross-threaded.
	Check crank to axle connection	Crank should be tightened securely to axle.
Clicking sound when pedaling	Check pedal to crank connection	Remove pedals and reattach fully.
	Check Locking Knob	Be sure the Locking Knob is clear of Fan.
Seat post movement	Check locking pin	Be sure adjustment pin is locked into one of the seat post adjustment holes.
	Check locking knob	Be sure knob is securely tightened.

## Validation

Appropriate and acceptable proof of purchase is required to validate your products warranty coverage.

## Coverage

Nautilus, Inc. warrants to the original purchaser of this machine that it is free from defects in materials and workmanship, when used for the purpose intended, under normal conditions, and provided it receives proper care and maintenance as set forth herein and as described in the products Assembly and Owner's manual. This warranty is extended and is valid only to the original purchaser and is not transferable or applicable to any other person(s) or companies. This warranty is good only for authentic, original, legitimate machines manufactured by Nautilus, Inc. and sold through an authorized agent and used in the United States or Canada.

## Terms

	Residential	Commercial
• Frame	15 years	10 years
• Mechanical parts	3 years	1 year
• Electronics	2 years	1 year
• Wear items	6 months	3 months
• Labor	6 months	3 months

(Labor support does not include the installation of replacement parts involved in the initial product assembly and preventative maintenance services.)

## Support

Throughout the terms of the warranty coverage, Nautilus, Inc. will repair any machine that proves to be defective in materials or workmanship. Nautilus reserves the right to replace the product in the event a repair is not possible. When Nautilus determines replacement is the correct remedy, Nautilus may apply a limited credit reimbursement toward another Nautilus, Inc. brand Product, at our discretion. This reimbursement may be prorated based on length of ownership. Nautilus, Inc. provides repair service within major metropolitan areas. Nautilus, Inc. reserves the right to charge the consumer for travel outside these areas. Nautilus, Inc. is not responsible for dealer labor or maintenance charges beyond the applicable warranty period(s) stated herein. Nautilus, Inc. reserves the right to substitute material, parts or products of equal or better quality if identical materials or products are not available at the time of service under this warranty. Any replacement of the product under the terms of the Warranty in no way extends the original Warranty period. Any limited credit reimbursement may be prorated based on length of ownership. THESE REMEDIES ARE THE EXCLUSIVE AND SOLE REMEDIES FOR ANY BREACH OF WARRANTY.

## Non-Coverage of Products under These Warranties

- Damage or injury due to abuse, accident, failure to properly assemble or maintain, tampering or modification of the unit, failure to follow instructions or warnings in the Owner's Manual including failure to properly educate and train end-users of the equipment if being used in a commercial setting, misuse, mishandling, accident, exposure to weather, or Acts of God (such as floods, tornadoes, hurricanes, power surges, etc.).
- Damage or injury caused by exceeding maximum user weights as defined in the products Owner's manual or warning label.
- Damage or injury due to normal usage and wear and tear or due to improper maintenance and repair.
- This warranty does not extend to any territories or countries outside the United States and Canada.

## Exclusions

The preceding warranties are the sole and exclusive express warranties made by Nautilus, Inc. They supersede any prior, contrary or additional representations, whether oral or written. No agent, representative, dealer, person or employee has the authority to alter or increase the obligations or limitations of this warranty. Any implied warranties, including the WARRANTY OF MERCHANTABILITY and any WARRANTY OF FITNESS FOR A PARTICULAR PURPOSE, are limited in duration to the term of the applicable express warranty provided above, whichever is longer. Some states do not allow limitations on how long an implied warranty lasts, so the above limitation may not apply to you.

## Limitation of Remedies

EXCEPT AS OTHERWISE REQUIRED BY APPLICABLE LAW, THE PURCHASER'S EXCLUSIVE REMEDY IS LIMITED TO REPAIR OR REPLACEMENT OF ANY COMPONENT DEEMED BY NAUTILUS, INC. TO BE DEFECTIVE UNDER THE TERMS AND CONDITIONS STATED HEREIN. IN NO EVENT WILL NAUTILUS, INC. BE LIABLE FOR ANY SPECIAL, CONSEQUENTIAL, INCIDENTAL, INDIRECT OR ECONOMIC DAMAGES, REGARDLESS OF THE THEORY OF LIABILITY (INCLUDING, WITHOUT LIMITATION, PRODUCT LIABILITY, NEGLIGENCE OR OTHER TORT) OR FOR ANY LOST REVENUE, PROFIT, DATA, PRIVACY OR FOR ANY PUNITIVE DAMAGES ARISING OUT OF OR RELATED TO THE USE OF THE FITNESS MACHINE EVEN IF NAUTILUS, INC. HAS BEEN ADVISED OF THE POSSIBILITY OF SUCH DAMAGES. THIS EXCLUSION AND LIMITATION SHALL APPLY EVEN IF ANY REMEDY FAILS OF ITS ESSENTIAL PURPOSE. SOME STATES DO NOT ALLOW THE EXCLUSION OR LIMITATION OF CONSEQUENTIAL OR INCIDENTAL TYPE DAMAGES SO THE ABOVE LIMITATION MAY NOT APPLY TO YOU.

## Service

For products purchased from a retail outlet or distributor, contact your retailer or distributor for warranty support. For products purchased directly from Nautilus, Inc. contact the Nautilus office listed on the Contacts page of the products Owner's manual. Shipping of any warranty replacement parts will be paid by Nautilus, Inc. if approved in advance.

## State Laws

This warranty gives you specific legal rights. You may also have other rights, which vary from state to state.

## Expirations

If the warranty has expired, Nautilus, Inc. may assist with replacements or repairs to parts and labor, but there will be a charged for these services. Contact a Nautilus® office for information on post-warranty parts and services. Nautilus® does not guarantee availability of spare parts after expiration of warranty period.

## International Purchases

If you purchased your machine outside of the United States consult your local distributor or dealer for warranty coverage.



Nautilus®  
004-4743.071512.A

Bowflex®

Schwinn® Fitness



Universal®