

MODELS: EW(O), MW(O), PW(O), IWO, IOWO

SAFETY IS EVERYONE'S RESPONSIBILITY. ALL DACOR APPLIANCES ARE DESIGNED AND CONSTRUCTED TO GIVE YOU MANY YEARS OF SAFE OPERATION. THE OPERATION WILL BE FURTHER ENHANCED IF PROPER CARE AND JUDGEMENT ARE EXERCISED IN THE USE AND MAINTENANCE OF THIS APPLIANCE.

IMPORTANT INFORMATION

- Operating Instructions
- Care and Cleaning Instructions
- Safety Tips



WARNINGS:

Must be followed carefully to avoid personal injury or damage.



NOTES:

Contains helpful hints and tips.

Please Read Before Using Your Warming Oven

Place Serial Number Label Here



To Our Valued Customer:

Congratulations on your purchase of the very latest in Dacor products! Our unique combination of features, style and performance make us The Life of the Kitchen, and a great addition to your home.

In order to familiarize yourself with the controls, functions, and full potential of your new Distinctive Appliance, we suggest that you thoroughly read this use & care manual, beginning with the **Important Safety Instructions** section.

All Dacor appliances are designed and manufactured with quality and pride, while working within the framework of our company value. Should you ever experience a problem with your product, please first check the **Before You Call for Service** section of this manual for guidance. It provides useful suggestions and remedies prior to calling for service.

Valuable customer input helps us to continuously improve our products and services, so please feel free to contact our Customer Service Team for assistance with any of your product support needs.

Dacor Customer Service
1440 Bridge Gate Drive
Diamond Bar, CA 91765

Telephone: (800) 793-0093
Fax: (626) 403-3130
Hours of Operation: Monday through Friday
6:00 A.M. to 5:00 P.M. Pacific Time
Web Site: www.Dacor.com

Thank you for choosing Dacor for your home. We are a company built by families for families and we are dedicated to serving yours. We are confident that your new Dacor product will deliver a high level of performance and enjoyment for many years to come.

Sincerely,

A handwritten signature in cursive script, appearing to read "Cheryl Crowe".

Cheryl Crowe
Director, Customer Satisfaction

TABLE OF CONTENTS	1
Purpose of this Manual	1
Product Registration.....	1
IMPORTANT INSTRUCTIONS	2
What To Do	2
What Not To Do.....	2
OVEN OPERATION	3-4
Timer and Manual On/Off Switch	3
Setting the Temperature	3
Preheating the Warming Oven.....	3
Selecting Humidity Control (select models).....	3-4
Warming of Serving Containers	4
Drawer Slide Maintenance	4
Removing the Drawer	5
Re-installing the Drawer.....	5
CARE AND CLEANING	5
Gasket.....	5
Painted Surfaces.....	5
Stainless Steel Surfaces	5
Other Metal Surfaces	5
Control Panel	5
Moist-Crisp Control (select models).....	5
Drawer Handle	5
Glass Surfaces.....	5
PROBLEM SOLVING	5
Troubleshooting	5
Product Maintenance	6
If You Need Service.....	6
PRODUCT WARRANTY	6
What Is Covered	6
What Is Not Covered.....	6

Purpose of This Manual

This **Use & Care Manual** is designed to enable you to properly operate and maintain your new warming oven. Please keep this manual handy for easy access and quick reference.

Additional information may be requested by e-mail, in writing or by phone. Contact the DACOR Customer Service Team. The address and phone number of this department are listed on the inside front cover of this manual.

Product Registration

 Please enter the information requested in the spaces provided below. This information will be required in the unlikely event that a service call becomes necessary:

Model No. _____ Serial No. _____

Date Purchased _____ Date Installed _____

Purchased From _____

Address _____

Phone _____

What to Do

1. Begin by ensuring proper installation and grounding of the appliance by a qualified technician according to the accompanying Installation Instructions. Have the installer show you where the fuse or junction box is located so that you know how and where to turn off power.
2. Ensure that the warming oven is used only by those individuals who are able to operate it properly.
3. Use the warming oven only for tasks expected at home as outlined in this manual.
4. Properly clean and maintain the warming oven as recommended in this manual.
5. Use only dry potholders when removing hot cookware to avoid steam burns.
6. Exercise caution when opening the warming oven drawer. Let hot air or steam escape before looking or reaching into the warming oven.
7. Preheat the warming oven before use.
8. Clean only those parts listed in this manual.



NOTE:

The IOWO model is the only model designed for towel warming applications. When installing the IOWO as a towel warmer, you must install the wire rack supplied with the product. Lay the rack on the drawer bottom and secure it, with the clip and screw, to the inside of the drawer.

What Not to Do

1. Do not use the warming oven for warming or heating the room.
2. Never allow children to sit or stand on any part of the warming oven. Do not let children play with the warming oven.
3. Do not store items of interest to children above the warming oven. Children could be burned or injured while climbing on the appliance.
4. Do not wear loose or hanging apparel while using the warming oven.
5. Do not store combustible, flammable or explosive materials in the warming oven or in adjacent cabinets.
6. Do not remove the warming oven drawer for cleaning until it is cool to the touch.
7. Do not repair or replace any part of the warming oven unless specifically recommended in the literature accompanying this appliance. All other service should be referred to a qualified technician.

8. Do not use water on grease fires. A violent steam explosion may result. Smother any flames with a lid, cookie sheet or flat tray. Flaming grease can be extinguished with baking soda or a foam extinguisher.
9. Do not allow potholders to touch hot surfaces. Do not use towels or bulky cloth as potholders.
10. Do not use commercial oven cleaners or oven liner protective coatings on any part of the oven.
11. Do not place more than 50 pounds in the drawer.
12. **DO NOT TOUCH THE TOP MOUNTED HEATING ELEMENT OR OTHER INTERIOR SURFACES OF THE WARMING OVEN** (All models except IOWO). Heating elements may be hot, even though they are dark in color. During and after use, do not touch or let clothing or other flammable materials contact the heating elements or interior surfaces of the warming oven until they have had sufficient time to cool. (All models except IOWO)
13. Do not heat unopened food containers, such as baby food jars and cans. Pressure build up may cause the container to burst and cause injury.
14. Do not use abrasive or caustic cleaners or detergents on this appliance, as these may cause permanent damage to surfaces. Do not use aerosol cleaners, as these may be flammable or cause corrosion of metal parts.
15. Do not use appliance to warm towels or any other combustible material, except as noted below.

If you received a damaged product, immediately contact your dealer or builder. Do not install or use a damaged appliance.

Timer and Manual On/Off Switch

The warming oven is equipped with an automatic shut-off timer and a manual On/Off push-button switch.

Automatic Shut-off Timer

The automatic shut-off timer is located on the left side of the control Panel. It can be set for durations from 15 minutes to four hours. This safety feature eliminates the possibility of accidentally leaving the warmer on for extended periods of time. After selecting the temperature, turn the timer knob clockwise to the desired duration. This causes the warming oven to heat. After the temperature and time are selected, the red Indicator Light, located between the knobs on the control panel, goes on. If the set time expires or the temperature knob is turned to the "OFF" position, the light goes out and the oven stops heating.

NOTE:

The "ON" light will cycle on and off during warming. When the "ON" light is on the heating element is also on.

Manual On/Off Switch

The manual on/off push-button switch is located between the knobs of the control panel and houses the red "ON Indicator Light". The automatic shut-off timer can be bypassed with the use of the manual switch, placing the Warming Oven in a constant "ON" mode.

WARNING:

In the manual "ON" position, the Warming Oven will remain on until the manual switch is turned off. Exercise caution when operating the unit in this mode.

NOTE:

The automatic shut-off timer should be kept in the "OFF" position when using the manual on/off switch. If the oven is in manual "ON" mode, and the timer is activated and the manual switch turned off, the unit will continue to heat the food until the timer turns the oven off. This can overheat your food.

Setting the Temperature

The temperature control knob is located on the right side of the control panel, immediately behind the warming oven drawer front. The temperature is controlled by a thermostat that cycles power to the heating element. The temperature settings range from a low of approximately 100°F ("LO" setting) to a high of approximately 200°F ("HI" setting).

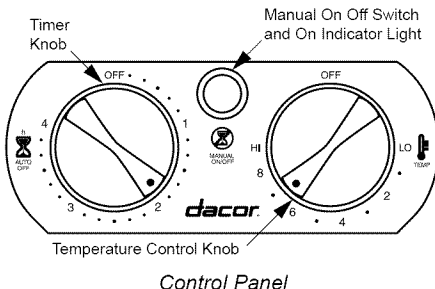

Preheating the Warming Oven

For best results, always preheat your warming oven. Placing hot food into a cool, confined area results in condensing of any steam that may be present. Preheating your warming oven reduces the likelihood of condensation. Preheat times vary for "LO", to "HI". Position the Moist•Crisp slide at the "MOIST" setting for more efficient preheating.

Selecting Humidity Control

(Not available on the IWO or IOWO models)

The warming oven has two distinct modes of operation. One, the "Moist" setting, seals the food's moisture in the warming chamber, maintaining the water content of the food. The "Crisp" setting allows the moisture to vent out of the warming oven, retaining the crispness of other food types. The Moist•Crisp Slide opens and closes vents located on the inside of the drawer front. In the crisp setting, the vents allow steam to escape out the sides of the drawer front, thereby reducing the moisture content of the warming chamber. In the moist setting, the closed vents retain the moisture in the warming oven.

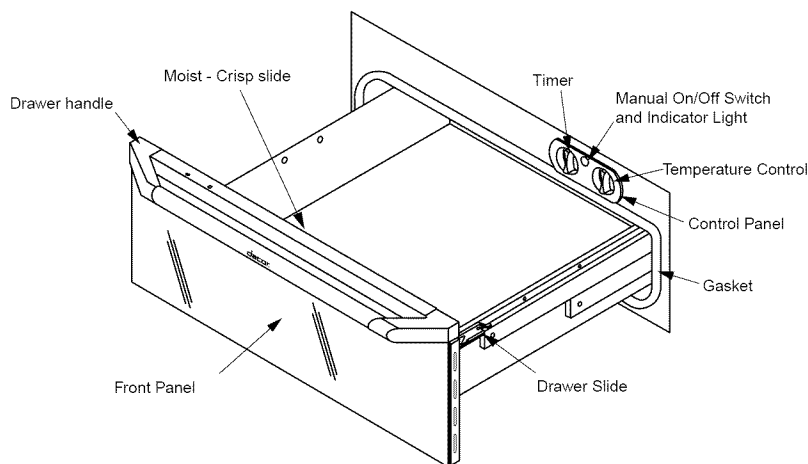

Warming Oven Features
(Epicure® EWO shown)

WARNING:

Do not obstruct the vents on the inside of the drawer and along the left and right sides of the drawer. Excessive heat buildup can occur.

NOTE:

Integrated models (IWO and IOWO) do not include Moist•Crisp Controls.

The slide control is located inside the drawer. To select the moist option, slide the control toward the [Moist icon]. For the crisp setting, slide the control toward the [Crisp icon]. The slide can also be positioned anywhere between the moist and crisp settings.

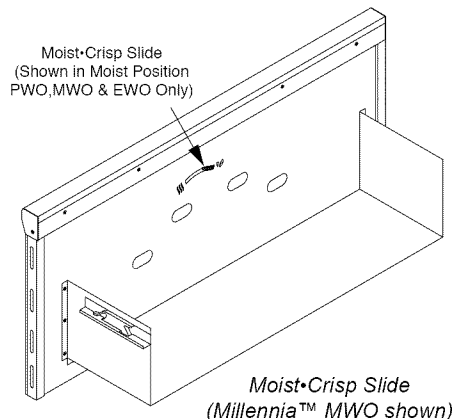

Warming of Serving Containers

To warm plates, and other serving containers, place them carefully into the warming oven and set the temperature anywhere between "LO" and 4, depending upon your personal preference. Do not drag plates across the drawer, as they may scratch the drawer surface. Before using any delicate dinnerware in the warming oven, determine its recommended maximum usage temperature from the plate manufacturer. It is not necessary to preheat the unit when warming serving dishes. Plastic wrapping on plates may be used. This is effective in keeping foods hot and moist.

WARNING:

Food safety is an important consideration when using a warming oven. Below a setting of 4, some bacterial growth may occur. Settings of 2 or less should not be used if holding certain foods for more than two to three hours.

Drawer Slide Maintenance

The warming oven features slides positioned on each side of the drawer. They allow the drawer to slide in and out smoothly, while enabling easy removal of the drawer from the warming oven chassis for thorough cleaning. No maintenance to the slides is required. The drawer and slides have a maximum load capacity of 50 pounds.

FOOD ITEMS	TEMPERATURE SETTING	MOIST•CRISP SELECTION	COVERED/ UNCOVERED
Bacon	HI	Crisp	Uncovered
Beef - Rare	4	Moist	Covered
Bread - Hard Rolls	4	Crisp	Uncovered
Bread - Proofing	LO-2	Moist	Damp Towel
Casseroles	4	Moist	Uncovered
Coffee Cake	4	Moist	Uncovered
Cooked Cereals	4	Moist	Uncovered
Dinner	6	Moist	Uncovered
Eggs	4	Moist	Covered
Enchiladas	4-6	Moist	Uncovered
Fish/Seafood	4	Moist	Covered
Fried Food	HI	Crisp	Uncovered
Gravy, Cream Sauces	4	Moist	Covered
Ham	4	Moist	Covered
Hors D' Oeuvres	4-6	Crisp	Uncovered
Lamb	4	Moist	Uncovered
Pancakes	4-6	Moist	Covered
Pies - Single Crust	4	Moist	Uncovered
Pizza	4-6	Moist	Covered
Potatoes - Baked	HI	Crisp	Uncovered
Poultry	HI	Moist	Uncovered
Vegetables	4	Moist	Covered
Waffles - Crisp	HI	Moist	Uncovered

Table 1: Temperature and Humidity Control Guidelines

Cleaning Stainless Steel Surfaces

⚠ If commercially available stainless steel cleaners are used, it is important to read the labels for the presence of chlorine compounds. Chlorine is a corrosive substance. If these compounds are present, rinse thoroughly and dry with a soft, lint-free cloth.

Otherwise, clean these surfaces with a solution of mild detergent and warm water. Rinse, dry and polish with a soft, lint-free cloth. **Always wipe stainless steel surfaces in the direction of the grain.**

Cleaning Other Metal Surfaces

Clean these surfaces with a solution of mild detergent and warm water. Rinse, dry and polish with a soft, lint-free cloth. If a commercially available polish is used, it is important to read the label for the presence of chlorine compounds. Chlorine is a corrosive substance and is not recommended for use with brass or chrome finishes. If these compounds are present, rinse surface thoroughly and dry with a soft, lint-free cloth.

Follow the manufacturer's instructions for application of polish.

Cleaning the Control Panel

Clean these parts with a solution of mild detergent and hot water. Rinse and dry with a soft cloth. It is recommended that the knobs and control panel be left in place for cleaning. Exercise caution to avoid introduction of liquids into the area behind the control panel. Do not use abrasive cleaners or scrubbers as they may permanently damage the finish or remove the silk-screened graphics.

Cleaning the Moist•Crisp Control

Clean the Moist•Crisp grip with a solution of mild detergent and hot water. Rinse and dry with a soft cloth.

Cleaning the Drawer Handle

Clean the drawer handle with a solution of mild detergent and hot water. Rinse and dry with a soft cloth.

⚠ WARNING:
DO NOT USE ABRASIVE CLEANERS OR SCRUBBERS. THEY WILL PERMANENTLY DAMAGE THE FINISH.

Cleaning Glass Surfaces

Clean all glass surfaces with a solution of mild detergent and hot water. Use a mild glass cleaner to remove fingerprints or smears. Dry completely with a soft, lint-free cloth.

Removing the Drawer

Pull the drawer out to the fully open position. Push in on the locking tab on one side as you pull the drawer up. When the drawer comes loose on the slide, repeat the same process on the opposite side. Grip the drawer on both sides and pull it free. For safety, push both drawer slides into the drawer opening.

Re-Installing the Drawer

Pull the drawer slides all the way out of the drawer opening. Gently lower the drawer between the extended slides until the drawer is suspended by the slide rails. Slide the back of the drawer mounting brackets under the drawer mounting clips on the slides. Push the side of the drawer down onto its locking tab, until the tab locks into place. Repeat the same process on the opposite side. Gently open and close the drawer to make sure that it is properly installed.

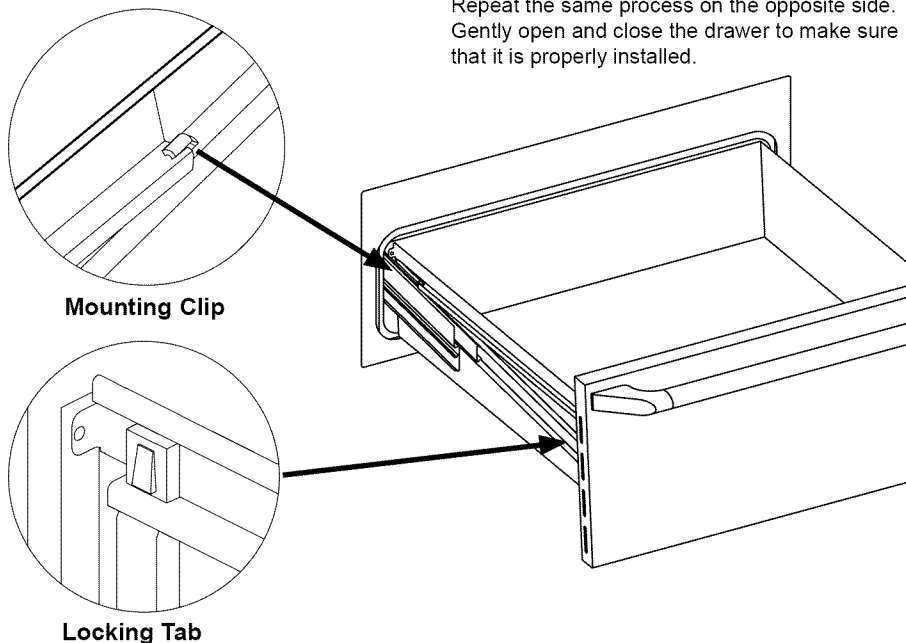

Cleaning the Gasket

Gently clean the gasket, located on the front frame, with a solution of mild detergent and hot water. Rinse and dry with a soft cloth. Be careful not to crush or damage the soft gasket material. Maintaining an effective heat seal is necessary to ensure maximum warming oven performance.

Cleaning Painted Surfaces

For the front faces of warming ovens with a painted finish, clean with a solution of mild detergent and hot water. Rinse and dry with a soft cloth. Do not use abrasive cleaners or scrubbers. They may permanently damage the finish.

Troubleshooting

Unnecessary service calls may be expensive, frustrating and time consuming. Before you call for service, please review the potential problems, possible causes and remedies shown in the table below.

Problem	Possible	Cause Remedy
1. Nothing works.	Timer is not set.	Set timer to "ON" position, up to four hours.
	Warming Oven is not connected to power.	Plug the Warming Oven into a 120-volt, 15 amp, dedicated electrical receptacle
	Power supply is not energized.	If no electrical receptacle exists, have a qualified electrician install one. Check house circuit breaker or fuses
2. Drawer does not slide smoothly, or drags.	Drawer is incorrectly mounted into slide mechanism.	Remount drawer into slide, per instructions on page 4.
	Drawer is over-loaded or the load is unbalanced	Reduce the weight to less than 50 pounds. Redistribute drawer contents
3. Excessive condensation.	Failure to preheat the Warming Oven.	Preheat the Warming Oven before each use.
	Incorrect Humidity Control setting.	Set Humidity Control to "Crisp" to allow venting of moisture.
4. "ON" light is off when both knobs are set correctly	Oven has reached the set temperature	This is normal

Troubleshooting Guide

Product Maintenance

No maintenance, other than the **CARE AND CLEANING INSTRUCTIONS** identified in this **Use & Care Manual**, should be attempted by the owner/operator. All other maintenance and service must be performed by a qualified appliance technician.

If You Need Service...

First, review the recommended checks listed in the preceding **Troubleshooting Guide**. Then, be certain that the appliance has been installed properly and is being operated correctly. Familiarize yourself with the warranty terms and conditions listed in the **PRODUCT WARRANTY** section.

If the above checks have been completed and the problem has not yet been remedied, call your local authorized DACOR service representative. Your dealer can normally provide the name and telephone number of the nearest service company.

DACOR works diligently to ensure your satisfaction when service is necessary. However, if you are not completely satisfied with the service provided, contact the company that performed the service and express why you are not pleased. Normally, they will be willing and able to resolve the problem.

If the service agency is not able to respond effectively, call or write the DACOR Customer Service Department. The phone number and address of this department are listed on the inside front cover of this manual. Please include your telephone number if you choose to write. We will then do our utmost to assure your happiness and satisfaction.

What Is Covered

CERTIFICATE OF WARRANTIES
DACOR WARMING OVENS

WITHIN THE FIFTY STATES OF THE U.S.A., THE DISTRICT OF COLUMBIA AND CANADA*:

FULL ONE-YEAR WARRANTY

If your DACOR product fails to function within one year of the original date of purchase, due to a defect in material or workmanship, DACOR will remedy the defect without charge to you or subsequent users. The owner must provide proof of purchase, upon request, and have the appliance accessible for service.

* Warranty is null and void if non-UL approved product is transported from the U.S.

OUTSIDE THE FIFTY STATES OF THE U.S.A., THE DISTRICT OF COLUMBIA AND CANADA:
LIMITED FIRST YEAR WARRANTY

If your DACOR product fails to function within one year of the original date of purchase, due to a defect in material or workmanship, DACOR will furnish a new part, F.O.B. factory, to replace the defective part. All delivery, installation and labor costs are the responsibility of the purchaser. The owner must provide proof of purchase, upon request, and have the appliance accessible for service.

What Is Not Covered

- Service calls to educate the customer in the proper use and care of the product.
- Failure of the product when used for commercial, business, rental or any application other than for residential consumer use.
- Replacement of house fuses or fuse boxes, or resetting of circuit breakers.

- Damage to the product caused by accident, fire, flood or other acts of God.
- Breakage, discoloration or damage to glass, metal surfaces, plastic components, trim, paint, or other cosmetic finish, caused by improper usage or care, abuse, or neglect.

THE REMEDIES PROVIDED FOR IN THE ABOVE EXPRESS WARRANTIES ARE THE SOLE AND EXCLUSIVE REMEDIES. THEREFORE, NO OTHER EXPRESS WARRANTIES ARE MADE, AND OUTSIDE THE FIFTY STATES OF THE UNITED STATES, THE DISTRICT OF COLUMBIA AND CANADA, ALL IMPLIED WARRANTIES, INCLUDING BUT NOT LIMITED TO, ANY IMPLIED WARRANTY OF MERCHANTABILITY OR FITNESS FOR A PARTICULAR USE OR PURPOSE, ARE LIMITED IN DURATION TO ONE YEAR FROM THE DATE OF ORIGINAL PURCHASE. IN NO EVENT SHALL DACOR BE LIABLE FOR INCIDENTAL EXPENSE OR CONSEQUENTIAL DAMAGES. NO WARRANTIES, EXPRESS OR IMPLIED, ARE MADE TO ANY BUYER FOR RESALE.

Some states do not allow limitations on how long an implied warranty lasts, or do not allow the exclusion or limitation of inconsequential damages, so the above limitations or exclusions may not apply to you. This warranty gives you specific legal rights, and you may also have other rights that vary from state to state.

fold here



NO POSTAGE
NECESSARY
IF MAILED
IN THE
UNITED STATES

BUSINESS REPLY MAIL
FIRST-CLASS MAIL PERMIT NO. 4507 DIAMOND BAR CA

POSTAGE WILL BE PAID BY ADDRESSEE

DACOR INC.
ATTN: WARRANTY PROCESSING DEPT
1440 BRIDGE GATE DR STE 200
PO BOX 6532
DIAMOND BAR CA 91765-9861

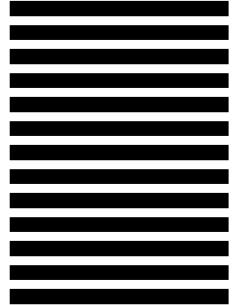



Please visit www.Dacor.com to activate your warranty online.

WARRANTY INFORMATION



IMPORTANT:

Your warranty will not be activated until you activate it online or return this form to Dacor. If you have purchased more than one Dacor product, please return all forms in one envelope or activate the warranty for each product online.

Please rest assured that under no conditions will Dacor sell your name or any of the information on this form for mailing list purposes. We are very grateful that you have chosen Dacor products for your home and do not consider the sale of such information to be a proper way of expressing our gratitude!

Owner's Name: _____
Last (Please Print or Type) First Middle

Street: _____

City: _____ State: _____ Zip: _____

Purchase Date: _____ Email: _____ Telephone: _____

Dealer: _____

City: _____ State: _____ Zip: _____

Your willingness to take a few seconds to fill in the section below will be sincerely appreciated. Thank you.

1. How were you **first** exposed to Dacor products? (Please check one only.)

- A. T.V. Cooking Show
- B. Magazine
- C. Appliance Dealer Showroom
- D. Kitchen Dealer Showroom
- E. Home Show
- F. Builder
- G. Architect/Designer
- H. Another Dacor Owner
- I. Model Home
- J. Other _____

2. Where did you buy your Dacor appliances?

- A. Appliance Dealer
- B. Kitchen Dealer
- C. Builder Supplier
- D. Builder
- E. Other _____

3. For what purpose was the product purchased?

- A. Replacement *only*
- B. Part of a Remodel
- C. New Home
- D. Other _____

4. What is your household income?

- A. Under \$75,000
- B. \$75,000 – \$100,000
- C. \$100,000 – \$150,000
- D. \$150,000 – \$200,000
- E. \$200,000 – \$250,000
- F. Over \$250,000

5. What other brands of appliances do you have in your kitchen?

- A. Cooktop _____
- B. Oven _____
- C. Dishwasher _____
- D. Refrigerator _____

6. Would you buy or recommend another Dacor product?

- Yes
- No

Comments: _____

Thank you very much for your assistance. The information you have provided will be extremely valuable in helping us plan for the future and giving you the support you deserve.

