

# INSTALLATION INSTRUCTIONS

## Apartment Fan Coil

Product Family: FSA2X, FSA4X, FEA4X, WAHA

**NOTE:** Read the entire instruction manual before starting installation.

### TABLE OF CONTENTS

	PAGE
SAFETY CONSIDERATIONS .....	1
INTRODUCTION .....	1
INSTALLATION .....	1
CHECK EQUIPMENT .....	1
MOUNT FAN COIL .....	2
DUCTWORK SPECIFICATIONS .....	3
CONDENSATE DRAIN .....	3
FIELD INSTALLATION OF CONTROLS .....	3
ELECTRICAL CONNECTIONS .....	3
SELECT PROPER BLOWER SPEED .....	4
START-UP .....	4
CARE AND MAINTENANCE .....	4
AIRFLOW PERFORMANCE .....	4

### SAFETY CONSIDERATIONS

Improper installation, adjustment, alteration, service, maintenance, or use can cause explosion, fire, electrical shock, or other conditions which may cause death, personal injury or property damage. Consult a qualified installer, service agency, or your distributor or branch for information or assistance. The qualified installer or agency must use factory-authorized kits or accessories when modifying this product. Refer to individual instructions packaged with kits or accessories when installing.

Follow all safety codes. Wear safety glasses, protective clothing, and work gloves. Use quenching cloth for brazing operations. Have a fire extinguisher available. Read these instructions thoroughly and follow all warning or cautions included in literature and attached to the unit. Consult local building codes and the current editions of the National Electrical Code (NEC) NFPA 70.

In Canada, refer to the current editions of Canadian Electrical Code CSA C22.1.

Recognize safety information. This is the safety alert symbol

⚠. When you see this symbol on the unit and in instructions or manuals, be alert to the potential for personal injury. Understand the signal words **DANGER**, **WARNING**, and **CAUTION**. These words are used with the safety alert symbol.

**DANGER** identifies the most serious hazards which **will** result in severe personal injury or death. **WARNING** signifies hazards which **could** result in personal injury or death. **CAUTION** is used to identify unsafe practices, which **may** result in minor personal injury or product and property damage. **NOTE** is used to highlight suggestions which **will** result in enhanced installation, reliability, or operation.

### INTRODUCTION

Fan Coils may be used for cooling or heat pump operation, with or without electric heat. Models are available with factory installed electric heaters (5 kW, 7.5 kW, or 11 kw) and with no heat. Installations without electric heat require a Cooling Control Kit (accessory part number AMWK001CK).

FEA and WAHA Fan Coils may be used for cooling or heat pump operation, with or without electric heat. Models have factory installed electric heaters (5 kW, 7.5 kW, or 11 kw).

FSA, FEA, and WAHA Fan Coils are designed to be installed in an **upflow position, free air return ONLY**, suitable for closet or flush-mount installations.

Units are designed for upflow applications only. Local codes may limit this free-air-return type unit to installation in single-level applications. When electric heater is not needed, a factory approved accessory cooling control package is required. See instructions packaged with accessory for installation procedures.

#### **WARNING**

##### **ELECTRICAL OPERATION HAZARD**

Failure to follow this warning could result in personal injury or death.

Before installing or servicing unit, always turn off all power to unit. There may be more than 1 disconnect switch. Turn off accessory heater power if applicable. Lock out and tag switch with a suitable warning label.

#### **CAUTION**

##### **CUT HAZARD**

Failure to follow this caution may result in personal injury.

Sheet metal parts may have sharp edges or burrs. Use care and wear appropriate protective clothing and gloves when handling parts.

### INSTALLATION

#### **Check Equipment**

Unpack unit and move to final location. Remove carton, taking care not to damage unit. Inspect equipment for damage prior to installation. File claim with shipping company if shipment is damaged or incomplete. Locate rating plate on unit. It contains information needed to properly install unit. Check rating plate to be sure unit matches job specifications. A front access panel is provided, which permits access to blower assembly and electrical controls for removal and servicing.

**NOTE:** Minimum clearance of 21" (533 mm) is required in front of access panel for servicing only. Installation clearance from

combustible materials is 0" (0 mm) from cabinet and supply-air duct (plenum included). Leave room for condensate pan and refrigerant line connection. (See **Figure 1** and **Figure 2**)

**⚠ CAUTION**

**PROPERTY DAMAGE HAZARD**

Failure to follow this caution may result in product or property damage.

Wrap a wet cloth around rear of fitting to prevent damage to TXV.

If using a TXV in conjunction with single-phase reciprocating compressor, a compressor start capacitor and relay are required. Consult outdoor unit pre-sale literature for start assist kit part number.

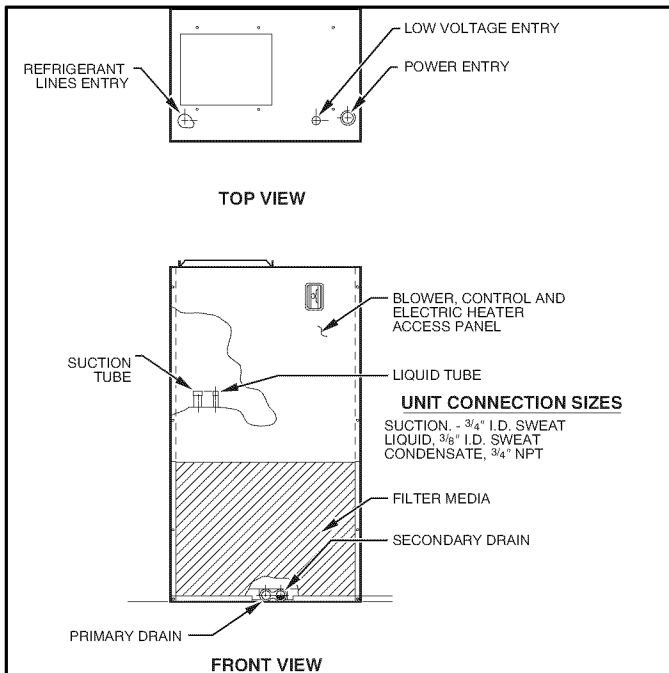

Figure 1 - Dimensional Drawing with Power Disconnect

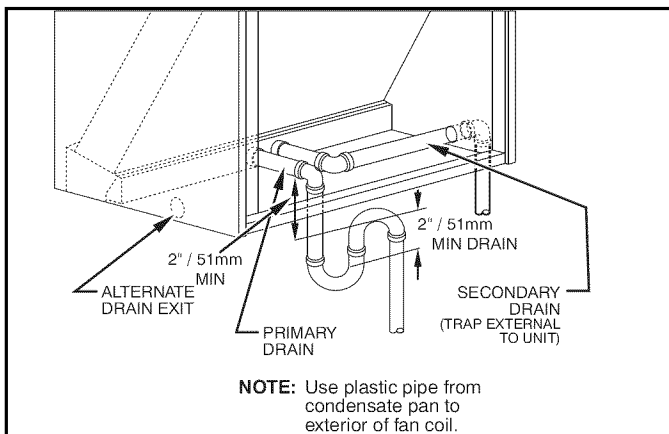
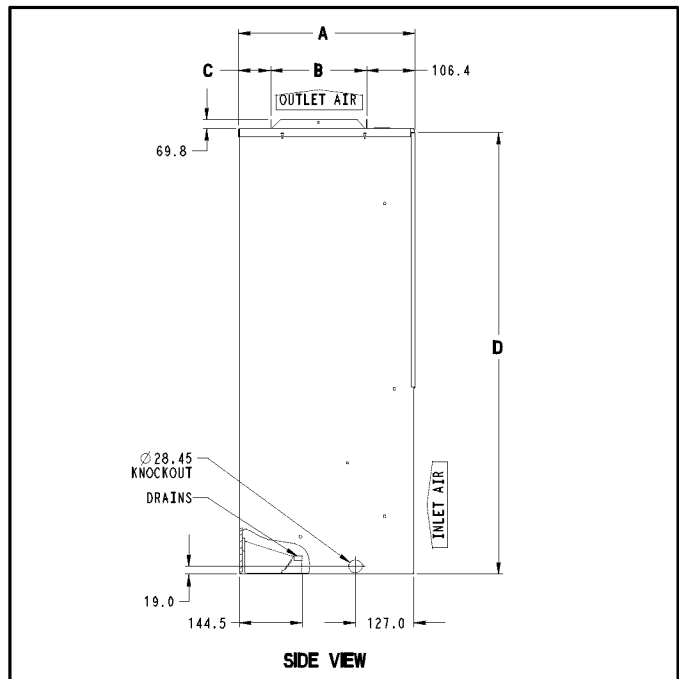

Figure 2 - Condensate Drain

A07427



DIMENSIONAL DATA (in.)					
Model Size	A	B	C	D	
FSA2X	18	153/16	81/4	23/4	381/16
	24	153/16	81/4	23/4	381/16
FSA4X	30	153/16	81/4	23/4	381/16
	36	183/8	91/4	5	433/16
Model Size	A	B	C	D	
FEA4X	18	153/16	81/4	23/4	381/16
	24	153/16	81/4	23/4	381/16
WAHA	30	183/8	91/4	5	433/16
	36	183/8	91/4	5	433/16

DIMENSIONAL DATA (mm)					
Model Size	A	B	C	D	
FSA2X	18	386	210	70	967
	24	386	210	70	967
FSA4X	30	386	210	70	967
	36	467	235	127	1097
Model Size	A	B	C	D	
FEA4X	18	386	210	70	967
	24	386	210	70	967
WAHA	30	467	235	127	1097
	36	467	235	127	1097

Figure 3 - Dimensions

### Mount Fan Coil

The unit is designed for free-air return as enclosed in a closet with louvered door or for flush mounting in a wall. A factory-authorized louvered grille kit is available for flush mount application (accessory part numbers AMWK001WG and AMWK002WG). When unit is installed in a closet with a louvered door in return-air path, the free area of louvered opening in the door must be a minimum of 2.25 ft<sup>2</sup> (.21 m<sup>2</sup>). Either align door opening with unit inlet or provide a 10" (254 mm) clearance between door and unit. If unit is to be flush mounted in a wall, provide adequate support underneath base of unit. To assure proper condensate drainage, be sure unit is level.

**NOTE:** Do not remove seals from coil until tubing connections are ready to be made. See instructions packaged with outdoor unit for connecting refrigerant tubes.

Move unit into place and install refrigerant tubing as follows:

1. Route tubing to connection points.
2. Remove plugs from liquid and suction tubes.
3. Braze connections using either silver bearing or non-silver bearing brazing material. Do not use soft solder (materials which melt below 800°F / 427°C). Consult local code requirements.
4. Pressurize system and leak-test. Repeat procedure until leak-free.

## ⚠ CAUTION

### ENVIRONMENTAL HAZARD

Failure to follow this caution may result in environmental damage.

Do not vent refrigerant to atmosphere. Recover during system repair or final unit disposal.

## Ductwork Specifications

Connect supply-air duct over 3/4" (19 mm) flange provided on supply-air opening. Secure duct to flange using applicable fasteners for type of duct used, and seal duct-to-unit joint.

**NOTE:** Short duct runs tend to increase noise level.

When fan coil is equipped with an electric heater, install air ducts in accordance with standards 90A and 90B of National Fire Protection Association (NFPA). Use of flexible connectors between ductwork and unit will prevent transmission of vibration. When electric heater is installed, use heat-resistant material for a flexible connector between ductwork and unit air discharge connection. Ductwork passing through unconditioned space must be insulated and covered with a vapor barrier.

**NOTE:** Unit is intended for nonducted return-air applications. Local codes may limit this unit to single-level applications.

## Condensate Drain

Condensate pan has primary and secondary drain connections to meet FHA requirements. (See **Figure 2**) These connections have 3/4" (19 mm) female pipe threads. Tubing for all condensate drains should be a minimum of 7/8" (22 mm) OD.

Drain lines from condensate pan to exterior of unit must be plastic pipe. Drain should be pitched downward at a slope of 1" per 10' (25 mm per 3 m). If coil is located in or above a living space where damage may result from condensate overflow, a separate 3/4" (19 mm) drain must be provided from secondary drain connection.

Run this drain to a place in compliance with local installation codes where it will be noticed when unit is operational. Condensate flow from secondary drain indicates a plugged primary drain.

Install a 2" (51 mm) trap in condensate drain line as close to coil as possible. Make sure that the top of trap is below connection to drain pan to prevent condensate from overflowing drain pan. Prime trap with water. Insulate trap if located above a living area and test condensate line for leaks. Consult local codes for additional restrictions or precautions.

## Field Installation of Controls

Units shipped from factory without controls require a field-installed cooling control kit or heater. These kits are completely assembled and factory-wired for easy installation. See Installation Instructions packaged with control panel for installation procedures. These unit Installation Instructions are to be used in conjunction with instructions packaged with heater or cooling control. When installing accessory heat, optional cooling control kit is not required.

## Electrical Connections

### ⚠ WARNING

#### ELECTRICAL OPERATION HAZARD

Failure to follow this warning could result in personal injury or death.

Before installing or servicing unit, always turn off all power to unit. There may be more than 1 disconnect switch. Turn off accessory heater power if applicable. Lock out and tag switch with a suitable warning label.

**NOTE:** Before proceeding with electrical connections, make certain that voltage, frequency, and phase correspond to that specified on rating plate. Also, check to be sure that the service provided by utility is sufficient to handle additional load imposed by this equipment.

Refer to unit wiring label for proper field high- and low-voltage wiring. Make all electrical connections in accordance with NEC and any local codes or ordinances that might apply. Unit must have a separate branch electrical circuit. When equipped with factory- or field-installed control kit, the fan coil has a factory-installed disconnect switch located within sight and readily accessible to the unit.

### ⚠ WARNING

#### ELECTRICAL SHOCK HAZARD

Failure to follow this warning could result in personal injury or death.

Field wires on side of disconnect found in fan coil remain live, even when pull-out is removed. Service and maintenance to incoming wiring cannot be performed until main disconnect switch (remote to the unit) is turned off. Lock out and tag switch with a suitable warning label.

Unit cabinet must have a continuous electrical path to ground in order to minimize potential for personal injury or death if an electrical fault should occur. This ground may consist of electrical wire or approved conduit when installed in accordance with existing codes.

**NOTE:** All control kits are shipped from factory wired for 230VAC transformer operation. For 208VAC operation, move black primary lead from 230VAC terminal to 208VAC terminal.

See Fig. 3 and 4 for field low-voltage wiring. See Fig. 1 for location of the electrical inlets. For maximum ampacity and over-current protection, see unit rating plate.

1. Provide power supply for unit being installed in accordance with unit wiring diagram and rating plate.
2. Connect line-voltage leads to field lugs. Use copper wire only.
3. Use UL listed conduit and conduit connector for connecting line-voltage leads to unit and obtaining proper ground. If conduit connection uses reducing washers, a separate ground wire must be used. Grounding can also be accomplished by using the ground lug provided in the control box.
4. Install rubber grommet packed with unit in hole for low-voltage wires.

5. Connect low-voltage leads to thermostat and outdoor unit. See **Figure 4** and **Figure 5** and the outdoor unit wiring label.

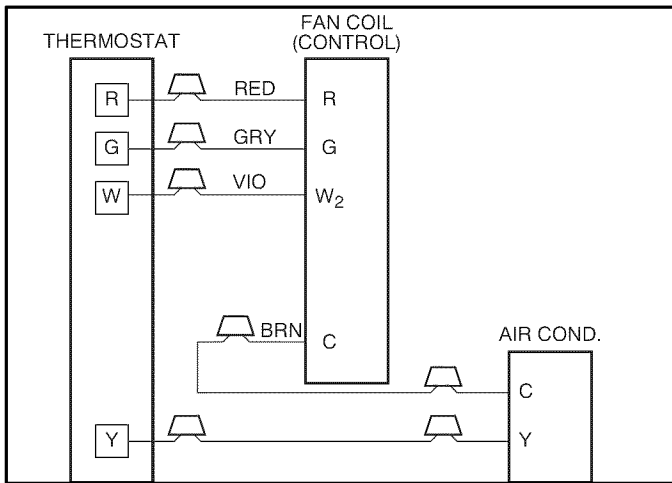

A98330

**Figure 4 – Wiring Layout Air Conditioning Unit (Cooling and 1-Stage Heat)**

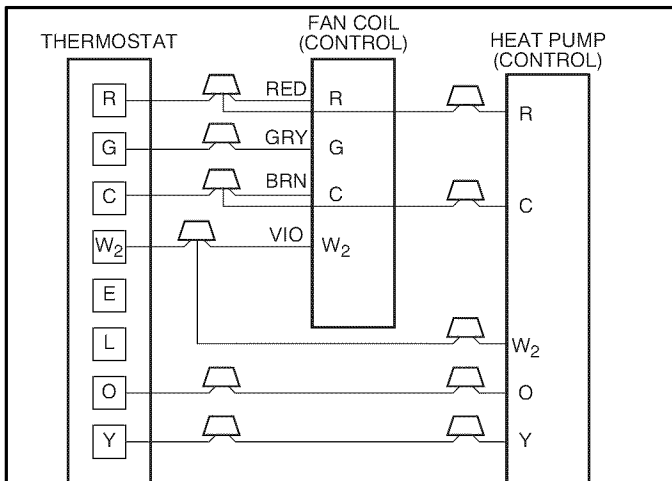

A98331

**Figure 5 – Wiring Layout Heat Pump Unit (Cooling and 2-Stage Heat)**

Refer to unit wiring instructions for recommended wiring procedures. Use No. 18 AWG color-coded, insulated (35°C

minimum) wire to make low-voltage connections between thermostat and unit. If thermostat is located more than 100 ft. (30m) from unit as measured along low-voltage wire, use No. 16 AWG color-coded, insulated (35°C minimum) wire.

**Model FSA**

All control kits from the factory utilize a printed-circuit board (PCB) which has a low voltage circuit protective fuse (5 amp.), fan motor speed tap selection terminal (SPT), and time delay relay(TDR) jumper. To disable the TDR feature, sever the jumper wire JW1. (TDR) jumper.

**Model FEA and WAHA**

There is a 90 second time delay off that cannot be disabled.

**Select Proper Blower Speed**

**Model FSA**

Before operating unit, be sure that proper blower speed has been selected. High speed tap is recommended for most applications. For those applications requiring lower air flows, low speed tap can be used.

Fan speeds are selected manually. To change the fan speed, interchange the black and red fan motor leads on printed circuit board terminal SPT (COM).

**Model FEA and WAHA**

Fan speeds are selected at the motor terminal block. To change motor speeds, disconnect fan lead from terminal 2 and move to desired tap; Low (1), Medium (2), High (3), and 0.50: static (5). With a call for thermostat W signal, the motor speed tap (4) will deliver the minimum airflow required for electric heat.

**START-UP**

Refer to outdoor unit Installation Instructions for system start-up instructions and refrigerant charging method details.

**CARE AND MAINTENANCE**

For continuing high performance and to minimize possible equipment failure, it is essential that periodic maintenance be performed on this equipment. Consult your local dealer as to proper frequency of maintenance and availability of a maintenance contract.

The ability to properly perform maintenance on this equipment requires certain mechanical skills and tools. If you do not possess these, contact your dealer for maintenance. The only consumer service recommended or required is filter maintenance.

**Table 1 – Airflow Performance (Model FSA)**

FSA UNIT SIZE	BLOWER SPEED	EXTERNAL STATIC PRESSURE (in. wc)					
		0.10	0.20	0.30	0.40	0.50	0.60
		CFM					
18	High	995	955	910	862	811	–
	Low	738	711	678	641	600	–
24	High	950	908	861	810	754	693
	Low	732	699	662	621	576	527
30	High	1128	1082	1030	973	911	845
	Low	1053	1011	964	911	854	791
36	High	1408	1355	1295	1227	1152	1068
	Low	1191	1157	1113	1061	1000	931

■ – Airflow outside 450 cfm/ton.

**NOTES:**

- Airflow based upon dry coil at 230v with factory approved filter and electric heater (2 element heater sizes 018 through 036). Airflow at 208 volts is approximately 10% lower.
- Not recommended for use above 0.60 in. wc external static pressure.

Table 2 – Airflow Performance (Model FEA and WAHA)

FEA and WAHA UNIT SIZE	Blower Speed	0.10	0.20	0.30	0.40	0.50	0.60
18	Tap 5	746	719	668	630	602	564
	Tap 4	611	568	539	496	451	420
	Tap 3	660	618	584	547	505	468
	Tap 2	611	568	539	496	451	420
	Tap 1	554	509	463	418	388	348
24	Tap 5	919	888	866	832	797	764
	Tap 4	736	707	653	611	579	528
	Tap 3	830	804	768	734	699	647
	Tap 2	736	707	653	611	579	528
	Tap 1	616	568	532	484	429	378
30	Tap 5	1110	1085	1049	1022	991	958
	Tap 4	1025	988	960	924	894	850
	Tap 3	1025	988	960	924	894	850
	Tap 2	904	864	839	797	762	716
	Tap 1	724	684	631	581	546	500
36	Tap 5	1353	1321	1282	1245	1195	1135
	Tap 4	1217	1190	1157	1128	1093	1054
	Tap 3	1072	1041	1007	968	920	886
	Tap 2	908	877	828	776	741	694
	Tap 1	731	670	612	576	524	488

– Airflow outside 450 cfm/ton.

NOTES:

1. Airflow based upon dry coil at 230v with factory approved filter and electric heater (2 element heater sizes 18 through 36).
2. Airflow at 208 volts is approximately the same as 230 volts because the X13 motor is a constant torque motor. The torque doesn't drop off at the speeds the motor operates.
3. Not recommended for use above 0.60 in. external static pressure.

Table 3 – Air Delivery Performance Correction Component Pressure Drop (in. wc) at Indicated Airflow (Dry-To-Wet Coil)

FSA UNIT SIZE	CFM								
	500	600	700	800	900	1000	1100	1200	1300
18	0.034	0.049	0.063	--	--	--	--	--	--
24	0.021	0.033	0.045	0.056	0.068	--	--	--	--
30	--	--	--	0.056	0.068	0.079	0.090	--	--
36	--	--	--	--	--	0.055	0.064	0.073	0.081

FEA and WAHA UNIT SIZE	CFM								
	500	600	700	800	900	1000	1100	1200	1300
18	0.034	0.049	0.063	--	--	--	--	--	--
24	0.021	0.033	0.045	0.056	0.068	--	--	--	--
30	--	--	--	0.056	0.068	0.079	0.090	--	--
36	--	--	--	--	--	0.055	0.064	0.073	0.081

Table 4 – Air Delivery Performance Correction Component Pressure Drop (in. wc) at Indicated Airflow

AIR DELIVERY (CFM)		400	500	600	700	800	900	1000	1100
Electric Heaters	1—Element 5 kW	0.007	0.010	0.015	0.025	0.035	0.055	0.070	0.080
	2—Element 7.5 & 11 kW	0.010	0.012	0.018	0.028	0.050	0.075	0.100	0.130

Subtract the above pressure drop corrections from unit airflow data when that component or condition is used. The remaining external static pressure will be available for the duct system.