

Operator's Manual

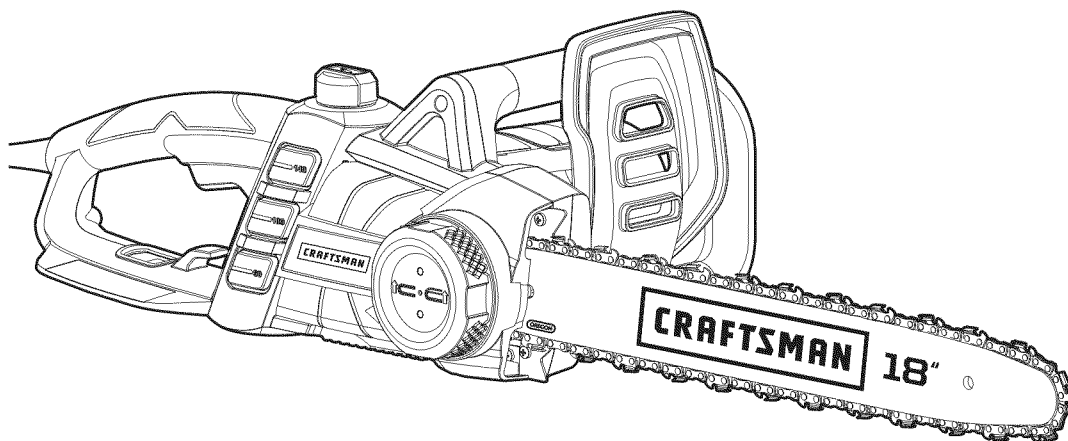

15 Amp/4.0 Peak HP Motor Electric Chain Saw

Model No.
172.34120 18-In. Bar



CAUTION: Read, understand and follow all Safety Rules and Operating Instructions in this Manual before using this product.

Sears Brands Management Corporation,
Hoffman Estates, IL 60179

See the full line of Craftsman® products
at craftsman.com

- WARRANTY
- SAFETY
- UNPACKING
- ASSEMBLY
- OPERATION
- MAINTENANCE
- PARTS LIST
- ESPAÑOL

TABLE OF CONTENTS

Warranty.....Page 2
 Safety Symbols.....Page 3
 Safety Instructions.....Pages 4 - 13
 Unpacking.....Page 13
 Description.....Pages 14 - 15
 Assembly and Adjustments.....Pages 16 - 18
 Operation Terms.....Pages 19
 Operation.....Pages 20 - 28
 Maintenance/Trouble Shooting.....Pages 29 - 30
 Specifications.....Pages 31
 Parts Lists.....Pages 32 - 34

CRAFTSMAN® TWO YEAR FULL WARRANTY

FOR TWO YEARS from the date of purchase, this product is warranted against any defects in material or workmanship. Defective product will be replaced free of charge.

For warranty coverage details or to obtain free replacement, visit the web site: www.craftsman.com

This warranty does not cover the bar and chain, which are expendable parts that can wear out from normal use within the warranty period.

This warranty is void if this product is ever used while providing commercial services or if rented to another person.

This warranty gives you specific legal rights, and you may also have other rights which vary from state to state.

Sears Brands Management Corporation, Hoffman Estates, IL 60179

NOTE: Chain and Bar Oil is not included. **BEFORE** using this Chain Saw, do not forget to purchase Craftsman Bar & Chain Oil, SAE30.



⚠ WARNING: Some dust created by using lawn and garden power tools contains chemicals known to the State of California to cause cancer and birth defects or other reproductive harm.

**SAVE THESE INSTRUCTIONS!
READ ALL INSTRUCTIONS!**

SAFETY SYMBOLS

The purpose of safety symbols is to attract your attention to possible dangers. The safety symbols and the explanations with them deserve your careful attention and understanding. The symbol warnings do not, by themselves, eliminate any danger. The instructions and warnings they give are no substitutes for proper accident prevention measures.

⚠ WARNING: Be sure to read and understand all safety instructions in this manual, including all safety alert symbols such as **“DANGER,” “WARNING,”** and **“CAUTION”** before using this rotary tool. Failure to follow all instructions listed in this manual may result in electric shock, fire and/or serious personal injury.

SYMBOL SIGNAL MEANING

⚠ SAFETY ALERT SYMBOL: Indicates **DANGER, WARNING, OR CAUTION.** May be used in conjunction with other symbols or pictographs.

⚠ DANGER: Indicates a hazardous situation which, if not avoided, will result in death or serious injury. This signal word is to be limited to the most extreme situations. Always follow the safety precautions to reduce the risk of fire, electric shock, and personal injury.

⚠ WARNING: Indicates a hazardous situation which, if not avoided, could result in death or serious injury. Always follow the safety precautions to reduce the risk of fire, electric shock, and personal injury.

⚠ CAUTION: Indicates a hazardous situation which, if not avoided, could result in minor or moderate injury.

Damage Prevention and Information Messages

These inform the user of important information and/or instructions that could lead to equipment or other property damage if they are not followed. Each message is preceded by the word **“NOTE,”** as in the example below:

NOTE: Equipment and/or property damage may result if these instructions are not followed.

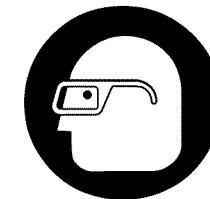

⚠ WARNING: To ensure safety and reliability, all repairs should be performed by a qualified service technician.

⚠ WARNING: The operation of any power tools can result in foreign objects being thrown into your eyes, which can result in severe eye damage. Before beginning power tool operation, always wear safety goggles or safety glasses with side shield and a full face shield when needed. We recommend a Wide Vision Safety Mask for use over eyeglasses or standard safety glasses with side shields. Always use eye protection which is marked to comply with ANSI Z87.1 shields.

SAFETY INSTRUCTIONS

⚠ WARNING: If correctly used, this electric Chain Saw is an efficient tool to use; if used improperly or without the due precautions it could become a dangerous tool. For pleasant and safe work, **ALWAYS** strictly comply with the safety rules that are contained in this manual.

⚠ WARNING: **BE SURE** to read and understand all instructions in this manual before using this electric Chain Saw. Failure to follow all instructions listed below may result in electric shock, fire and/or serious personal injury.

⚠ WARNING: To avoid mistakes that could cause serious injury, **DO NOT** connect the Chain Saw to the power source until the following instructions have been read and understood.

WORK AREA SAFETY

⚠ WARNING: Consider the work area environment. Use extreme caution when cutting small size brush and saplings because the slender material may catch the saw chain and be whipped toward you or pull you off balance. **DO NOT** operate a chain saw in a tree unless specifically trained to do so. When cutting a limb that is under tension be alert for spring back so that you will not be struck when the tension in the wood fibers is released.

- ALWAYS** avoid dangerous conditions. **DO NOT** use in wet, damp areas or expose to rain.
- DO NOT operate in the presence of flammable liquids, gases, or dust.** Electric tools create sparks which may ignite dust or fumes.
- ALWAYS keep bystanders and visitors at a safe distance while operating this Chain Saw. NEVER allow children or pets near the tool.** Flying objects can injure anyone in the area.
- CHILDPROOF your tools** with padlocks and master switches. Lock tools away when not in use. This Chain Saw is not a toy.
- DO NOT** use the Chain Saw without adequate lighting. **ALWAYS** make sure that you can see what you are cutting.
- BEFORE** using the Chain Saw, remove any debris or objects that could be entangled in or thrown by the Chain Saw.

PERSONAL SAFETY

⚠ WARNING: The operation of any Chain Saw can result in **FOREIGN OBJECTS BEING THROWN**, which can result in personal injury or property damage. **ALWAYS** use proper safety equipment.

- KNOW your tool.** Read the operator's manual carefully. Learn the electric Chain Saw's applications and limitations, as well as the specific potential hazards related to this tool.
- STAY ALERT,** watch what you are doing and use common sense when operating this tool.
- DO NOT use tool while tired** or under the influence of drugs, alcohol or medication. A moment of inattention while operating this tool may result in serious personal injury.
- DRESS PROPERLY, USE SAFETY EQUIPMENT.** Always wear safety goggles with side shields (non-fogging and vented) or full face shield, proper work shoes, steel-toe with rubber non-slip soles, heavy-duty non-slip rubber gloves, dust mask or respirator and hearing protection. Regular users should have hearing checked regularly, as chain saw noise can damage hearing. Wear long protective pants and long sleeves to protect arms and legs.

SAFETY INSTRUCTIONS cont.

PERSONAL SAFETY cont.

- (cont.) **DO NOT** wear loose clothing or jewelry. Keep your hair, clothing, and gloves away from moving parts. Loose clothing or long hair can be caught in moving parts.
- DO NOT overreach.** Keep proper footing and balance at all times. Proper footing and balance enables better control of the tool in unexpected situations.
- Keep all parts of the body away from the saw chain when the motor is operating.

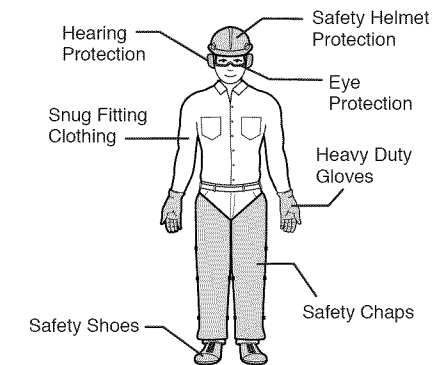

TOOL USE AND CARE SAFETY

⚠ WARNING: **BE SURE** to read and understand all instructions before operating this tool. Failure to follow all instructions listed below may result in electric shock, fire and/or serious personal injury.

- DO NOT use the tool if switch does not turn it "On" or "Off".** Any tool that cannot be controlled with the switch is dangerous and must be repaired.
- DISCONNECT the plug from the power source before making any adjustments or storing the tool.** Such preventive safety measures reduce the risk of starting the tool accidentally.
- STORE idle tools out of the reach of children and other untrained persons. Children MUST NOT operate the tool.** Tools are dangerous in the hands of untrained users.
- MAINTAIN tools with care. ALWAYS** keep cutting tools clean and in good working order.
- CHECK for misalignment or binding of moving parts, breakage of parts,** and any other condition that may affect the tool's operation. **If damaged,** have the tool serviced before using. Many accidents are caused by poorly maintained tools.
- USE ONLY chains that are recommended for this Chain Saw.** Chains that may be suitable for one Chain Saw may become hazardous when used on another Chain Saw.

ELECTRICAL SAFETY

⚠ WARNING: Do not permit fingers to touch the terminals of plug when installing or removing the extension cord from the plug.

- Double insulated tools are equipped with a polarized plug (one blade is wider than the other and will require the use of a polarized extension cord). The Chain Saw's plug will fit into a polarized extension cord only one way. If the plug does not fit fully into the extension cord, reverse the plug. If the plug still does not fit, obtain a correct polarized extension cord. A polarized extension cord will require the use of a polarized wall outlet. This plug will fit into the polarized wall outlet only one way. If the plug does not fit fully into the wall outlet, reverse the plug. If the plug still does not fit, contact a qualified electrician to install the proper outlet. **Do not change or alter** the equipment plug, extension cord receptacle, or extension cord plug in any way.
- Double insulation eliminates the need for the three-wire grounded power cord and grounded power supply system. Applicable only to Class II (double-insulated) tools. This Chain Saw is a double insulated tool.

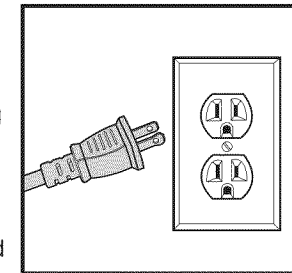

SAFETY INSTRUCTIONS cont.

ELECTRICAL SAFETY cont.

⚠ WARNING: GFCI (Ground Fault Circuit Interrupter) protection should be provided on all circuits or outlets to be used for electric chain saws and lawn and garden power tools. Receptacles are available having built-in GFCI protection and should be used for this measure of protection.

⚠ WARNING: Double insulation DOES NOT take the place of normal safety precautions when operating this tool.

⚠ WARNING: Guard against electric shock: Prevent body contact with grounded surfaces. For example: metal pipes, wire fences.

3. **BEFORE** plugging in the tool, **BE SURE** that the outlet voltage supplied is within the voltage marked on the tool's data plate. **DO NOT** use "AC only" rated tools with a DC power supply.
4. **DO NOT** expose tools to rain or wet conditions or use electric tools in wet or damp locations. Water entering an electric tool will increase the risk of electric shock.
5. **If operating an electric tool in damp locations is unavoidable, ALWAYS USE a Ground Fault Circuit Interrupter to supply power to your tool. ALWAYS WEAR electrician's rubber gloves and footwear in damp conditions.**
6. When operating a power tool outside, **ALWAYS** use an outdoor extension cord marked "W-A" or "W". these cords are rated for outdoor use and reduce the risk of electric shock.
7. **INSPECT tool cords for damage.** Have damaged tool cords repaired at a Sears Service Center. **BE SURE** to stay constantly aware of the cord location and keep it well away from the cutting blade.
8. **DO NOT** abuse the extension cord. **NEVER** use the cord to carry the tool by or to pull the plug from the outlet. Keep cord away from heat, oil, sharp edges or moving parts. Replace damaged cords immediately. Damaged cords increase the risk of electric shock.

EXTENSION CORDS

Use a proper extension cord. **ONLY** use cords listed by Underwriters Laboratories (UL). Other extension cords can cause a drop in line voltage, resulting in a loss of power and overheating of tool.

For this tool an AWG (American Wire Gauge) size of a least 14-gauge is recommended for an extension cord of 25-ft. or less in length. Use 12-gauge for an extension cord of 50-ft. **Extension cords 100-ft. or longer are not recommended.**

Remember, a **smaller wire gauge size has greater capacity than a larger number** (14-gauge wire has more capacity than 16-gauge wire; 12-gauge wire has more capacity than 14-gauge). When in doubt use the smaller number.

When operating a power tool outdoors, use an outdoor extension cord marked "W-A" or "W". These cords are rated for outdoor use and reduce the risk of electric shock.















⚠ CAUTION: Keep the extension cord clear of the work area. Position the cord so that it will not get caught on bushes, hedges, tree trunks, lawnmowers or other obstructions while you are working with the Chain Saw.

⚠ WARNING: Check extension cords before each use. If damaged replace immediately. Never use tool with a damaged cord since touching the damaged area could cause electrical shock, resulting in serious injury.

SAFETY INSTRUCTIONS cont.

SAFETY SYMBOLS FOR YOUR TOOL

The label on your tool may include the following symbols.

- | | |
|--|---|
| V.....Volts | Protective goggles/visor, helmet & hearing protection. |
| A.....Amps | Gloves with saw protection. |
| Hz.....Hertz | Boots with saw protection, steel-toe cap and non-slip sole. |
| W.....Watts | Do not use one handed when operating the chain saw. |
| min.....Minutes | Always use two hands when operating the chain saw. |
| ~.....Alternating current | Class II construction, Double-Insulation. When servicing, use only identical replacement parts. |
| ≡.....Direct current | The chain saw kickback angle is 10°, with a chain stop. |
| noNo-load speed | Correct Direction of Cutting-Teeth. |
| .../min.....Revolutions or Strokes per minute | Chain Stop |
| Indicates danger, warning or caution. It means attention! Your safety is involved. | Tip contact may cause the guide bar to move suddenly upward and backwards, which may cause serious injury to user. |
| Tip contact may cause the guide bar to move suddenly upward and backwards, which may cause serious injury to user. | Contact of the guide bar tip with any object should be avoided. |
| Read and follow all safety precautions in the owner's manual Failure to follow to instruction could result in serious injury to user. | |

SERVICE SAFETY

1. **If any part of this Chain Saw is missing or should break, bend, or fail in any way; or should any electrical component fail to perform properly: SHUT OFF** the power switch and remove the power cord from the Chain Saw and have the missing, damaged or failed parts replaced **BEFORE** resuming operation.
2. **Tool service should be performed at a qualified service dealer or repair center.** Service or maintenance performed by unqualified personnel could result in a risk of injury.
3. **When servicing a tool, use only identical replacement parts. Follow instructions in the maintenance section of this manual.** Use of unauthorized parts or failure to follow maintenance instructions may create a risk of electric shock or injury.

SAFETY RULES FOR ELECTRIC CHAIN SAWS

1. **KNOW your electric Chain Saw. Read operator's manual carefully.** Learn the applications and limitations, as well as the specific potential hazards related to this tool. Following this rule will reduce the risk of electric shock, fire or serious injury.
2. **DO NOT** use the Chain Saw without adequate lighting. **ALWAYS** make sure that you can see what you are cutting.
3. Use Chain Saw **ONLY** when wood is dry.
4. **ALWAYS** stand to the left of the Handle. Any debris thrown by the Chain Saw would be coming from the Blade Guard area on the right of the Chain Saw.

SAFETY INSTRUCTIONS cont.

SAFETY RULES FOR ELECTRIC CHAIN SAWS cont.

5. **ALWAYS** remove objects such as sticks and debris from the cutting path that could become entangled in, or thrown by the Chain Saw.
6. **DO NOT** start cutting until you have a clear work area, secure footing, especially if you are felling a tree, a retreat path. Keep work area clean.
7. **DO NOT** operate with one hand. Serious injury to the operator, helpers, or bystanders may result from one handed operation. A chain saw is intended for two-handed use.
8. **DO NOT** operate saw from a ladder or in a tree.
9. **MAKE SURE** the chain will not make contact with any object while starting the saw. **NEVER** start the saw when the guide bar is in a cut.
10. **DO NOT** force chain saw. It will do the job better and safer at the rate for which it was intended.
11. **DO NOT** put pressure on the saw, especially at the end of the cut. Doing so can cause you to lose control when the cut is completed.
12. **STOP** the saw before setting it down.
13. Hand carry saw **ONLY** when motor is stopped. Carry the chain saw by the front handle with the saw stopped, finger off the switch, the guide bar and saw chain to the rear.
14. Use the right tool, **CUT WOOD ONLY**. Don't use chain saw for purpose not intended; for example, don't use chain saw for cutting plastic, masonry, non-wood building materials.
15. **DO NOT** operate a chain saw that is damaged, improperly adjusted, or not completely and securely assembled. Always replace bar, chain, hand guard, or other parts immediately if they become damaged, broken, or are otherwise removed.
16. **Tool service should be performed at a Sears Parts and Repair Center** or other qualified service dealer. Service or maintenance performed by unqualified personnel could result in a risk of injury.

⚠ WARNING: Some dust particles created by lawn and garden tools contain chemicals known to the state of California to cause cancer, birth defects or other reproductive harm. Some examples of these chemicals are:

- Compounds in fertilizers, herbicides, pesticides, and insecticides.
- Arsenic and chromium from chemically treated lumber.

Your risk from these exposures varies, depending upon how often you do this type of work. To reduce your exposure to these chemicals:

- Work in a well-ventilated area
- Work with approved safety equipment, such as those dust masks that are specially designed to filter out microscopic particles.

1. Have all chain saw service performed by a qualified service dealer or repair center except the items listed in the **MAINTENANCE** section of this manual.
2. **MAKE CERTAIN** saw chain stops moving when trigger switch is released.
3. **KEEP** the handles dry and clean and free from oil and grease.
4. **KEEP** oil cap and fasteners securely tightened.
5. Nonconforming replacement components or the removal of safety devices may cause damage to the unit and possible injury to the operator or bystanders. **Use only** Craftsman accessories and replacement parts as recommended. **Never** modify your saw.

SAFETY INSTRUCTIONS cont.

SAFETY RULES FOR ELECTRIC CHAIN SAWS cont.

6. **MAINTAIN** chain saw with care.
7. **KEEP** unit sharp and clean for better and safer performance.
8. **FOLLOW INSTRUCTIONS** for lubricating and changing accessories.
9. **UNPLUG** the chain saw from the power source when not in use, before servicing, and when changing accessories and attachments, such as saw chain and guard.
10. **CHECK FOR DAMAGED PARTS.** Before further use of the chain saw, a guard or other part that is damaged should be carefully checked to determine that it will operate properly and perform its intended function. **CHECK** for alignment of moving parts, binding of moving parts, breakage of parts, mounting and any other conditions that may affect its operation. A guard or other part that is damaged should be properly repaired or replaced by a qualified service dealer or repair center unless otherwise indicated elsewhere in the operator's manual.
11. **WHEN NOT IN USE**, chain saws should be stored in a dry, high or locked-up place out of the reach of children.
12. **WHEN STORING SAW**, unplug and use a bar sheath or carrying case.

⚠ WARNING: NEVER reach under the Chain Saw (chain area) until you have unplugged Chain Saw and the Chain has come to a complete stop. The Chain Saw's chain will continue to rotate for a few seconds after it is switched off.

ADDITIONAL RULES FOR SAFE OPERATION

⚠ WARNING: BE SURE to read and understand all instructions. Failure to follow all instructions listed below may result in electric shock, fire and/or serious personal injury.

1. **ALWAYS wear safety goggles or safety glasses with side shields, and a full-face shield when using this Chain Saw.** We recommend a Wide Vision Safety Mask for use over eyeglasses or standard safety glasses with side-shield, available at Sears Stores or other Craftsman Outlets.
2. **PROTECT your lungs.** Wear a face mask, dust mask or respirator if the operation is dusty.
3. **PROTECT your hearing.** Wear appropriate personal hearing protection during use. Under some conditions noise from this product may contribute to hearing loss.
4. **WEAR** protective clothing and hard/safety helmet.
5. **ALL VISITORS AND BYSTANDERS MUST** wear the same safety equipment that the operator of the tool wears.
6. **ALWAYS check the tool for damaged parts.** Check for misalignment or binding of moving parts, breakage of parts, and any other condition that may affect the tool's operation. Before further use of the tool, a guard or other part that is damaged should be carefully checked to determine if it will operate properly and perform its intended function. A guard or other part that is damaged should be properly repaired or replaced at a qualified service dealer or repair center service dealer.

SAFETY INSTRUCTIONS cont.

ADDITIONAL RULES FOR SAFE OPERATION cont.

⚠ WARNING: Follow all safety rules to help prevent Kickback which can cause serious personal injury.

KICKBACK

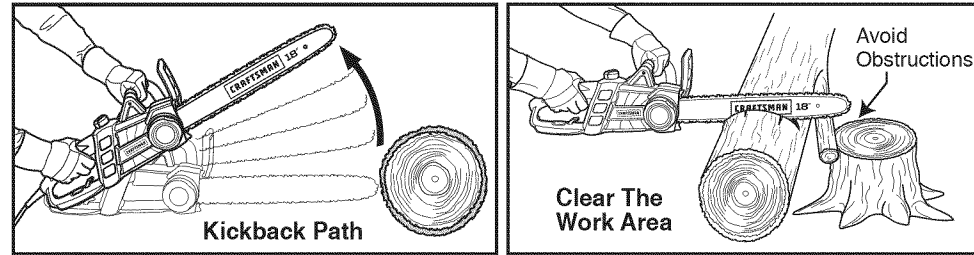

1. **KICKBACK** is the backward, upward or sudden forward motion of the guide bar occurring when the saw chain near the upper tip of the guide bar contacts any object such as a log or branch, or when the wood closes in and pinches chain in the cut. Contacting a foreign object in the wood can also result in loss of chain saw control.
2. **ROTATIONAL KICKBACK** can occur when the moving chain contacts an object at the upper tip of the guide bar. This contact can cause the chain to dig into the object, which stops the chain for an instant. The result is a lightning fast, reverse reaction which kicks the guide bar up and back toward the operator.
3. **PINCH-KICKBACK** can occur when the wood closes in and pinches the moving saw chain in the cut along the top of the guide bar and the saw chain is suddenly stopped. This sudden stopping of the chain results in a reversal of the chain force used to cut wood and causes the saw to move in the opposite direction of the chain rotation. The saw is driven straight back toward the operator.
4. **PULL-IN** can occur when the moving chain contacts a foreign object in the wood in the cut along the bottom of the guide bar and the saw chain is suddenly stopped. This sudden stopping pulls the saw forward and away from the operator and could easily cause the operator to lose control of the saw.

HELP PREVENT KICKBACK

1. Recognize that kickback can happen. With a basic understanding of kickback, you can reduce the element of surprise which contributes to accidents.
2. Never let the moving chain contact any object at the tip of the guide bar.
3. Keep working area free from obstructions such as other trees, branches, rocks, fences, stumps, etc. Eliminate or avoid any obstruction that your saw chain could hit while cutting.
4. When cutting a branch, do not let the guide bar contact another branch or other objects around it.
5. Keep saw chain sharp and properly tensioned. A loose or dull chain can increase the chance of kickback. Follow manufacturer's chain sharpening and maintenance instructions. Check tension at regular intervals, but never with engine running. Make sure bar clamp nuts are securely tightened.
6. Begin and continue cutting at full speed. If the chain is moving at a slower speed, there is greater chance of kickback occurring.
7. Use extreme caution when re-entering a cut.

SAFETY INSTRUCTIONS cont.

ADDITIONAL RULES FOR SAFE OPERATION cont.

HELP PREVENT KICKBACK cont.

8. Do not attempt cuts starting with the tip of the bar (plunge cuts).
9. Watch for shifting logs or other objects that could close a cut and pinch or fall onto chain.
10. Use the specified Reduced-Kickback Guide Bar and Low Kickback Chain.

AVOID PINCH-KICKBACK

1. Be extremely aware of situations or obstructions that can cause material to pinch the top of or otherwise stop the chain.
2. Do not cut more than one log at a time.
3. Do not twist the saw as the bar is withdrawn from an undercut when bucking.

AVOID PULL-IN

1. Always begin cutting with the saw at full speed and the saw housing against wood.
2. Use wedges made of plastic or wood. Never use metal to hold the cut open.

⚠ WARNING: Follow all safety rules to help prevent Kickback which can cause serious personal injury.

MAINTAIN CONTROL

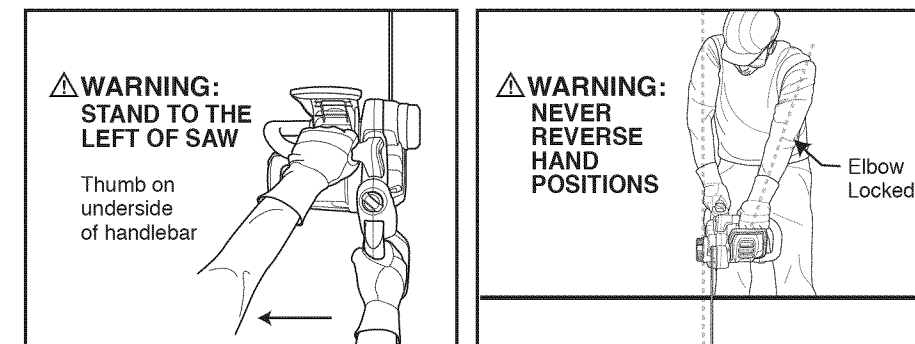

1. A good, firm grip on the saw with both hands will help you maintain control. Don't let go. Grip the rear handle with your right hand whether you are right or left handed. Wrap the fingers of your left hand over and around the front handlebar, and your left thumb under the front handlebar. Keep your left arm straight with the elbow locked.
2. Position your left hand on the front handlebar so it is in a straight line with your right hand on the rear handle when making bucking cuts. Stand slightly to the left side of the saw to keep your body from being in a direct line with the cutting chain.
3. Stand with your weight evenly balanced on both feet.
4. Do not overreach. You could be drawn or thrown off balance and lose control.
5. Do not cut above shoulder height. It is difficult to maintain control of saw above shoulder height.

SAFETY INSTRUCTIONS cont.

ADDITIONAL RULES FOR SAFE OPERATION cont.

KICKBACK SAFETY FEATURES

⚠ WARNING: The following features are included on your saw to help reduce hazard of kickback; however, such features will not totally eliminate this danger. Do not rely only on safety devices. Follow all safety rules to help avoid kickback and other forces which can result in serious injury.

1. **Hand Guard:** designed to reduce the chance of your left hand contacting the chain if your hand slips off the front handlebar.
2. **Position of Front and Rear Handle Bars AVOID KICKBACK:** designed with distance between handles and "in-line" with each other. The spread and "in-line" position of the hands provided by this design work together to give balance and resistance in controlling the pivot of the saw back toward the operator if kick back occurs.
3. **Reduced-Kickback Guide Bar:** designed with a small radius tip which reduces the size of the kickback danger zone on the bar tip, see Fig. A below. This type of bar has been demonstrated to significantly reduce the number and seriousness of kickbacks when tested in accordance with ANSI B175.1.

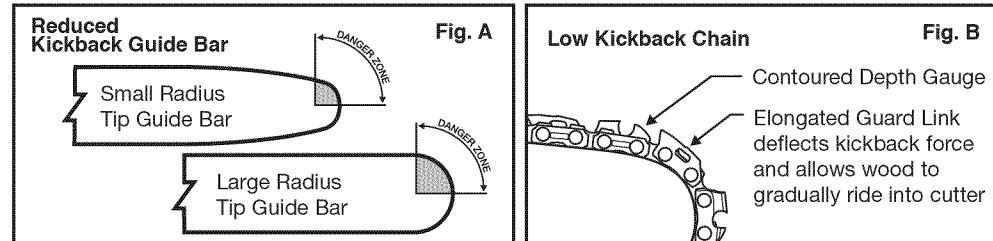

4. **Low Kickback Chain** has met kickback performance requirements when tested on the representative sample of these chain saws specified in ANSI B175.1. See Fig. B above.

⚠ CAUTION: Do not use a replacement saw chain unless: a.) It has been designated as meeting the ANSI B175 kickback performance requirements on that specific power head; b.) It has been designated as "Low- Kickback" saw chain in accordance with ANSI B175.1; or c.) It is the saw manufacturer's replacement catalogue (or equivalent) number.

CHAIN BRAKE (Built-In, Automatic and Manual Systems) See page 21, Figs. 8-9

1. **Chain Brake:** This Chain Saw is designed to stop the chain in the event of a kickback. Both built-in, **Automatic and Manual Chain Brake** Systems reduce kick-back.

⚠ WARNING: WE DO NOT REPRESENT AND YOU SHOULD NOT ASSUME THAT THE CHAIN BRAKE WILL PROTECT YOU IN THE EVENT OF A KICKBACK. Kickback is a lightning fast action which throws the bar and rotating chain back and up toward the operator. Kickback can be caused by allowing contact of the bar tip in the danger zone with any hard object. Kickback can also be caused by pinching the saw chain along the top of the guide bar. This action may push the guide bar rapidly back toward the operator. Either of these events may cause you to lose control of the saw which could result in serious injury or even death. **DO NOT RELY UPON ANY OF THE SAFETY DEVICES BUILT INTO YOUR SAW. YOU SHOULD USE THE SAW PROPERLY AND CAREFULLY TO AVOID KICKBACK.** Reduced-Kickback guide bars and low-kickback saw chains reduce the chance and magnitude of kickback and are recommended. Your saw has a low kickback chain and bar as original equipment. Repairs on a chain brake should be made by a qualified service dealer or repair center. Take your unit to the place of purchase if purchased from a servicing dealer, or to your nearest qualified service dealer or repair center.

SAFETY INSTRUCTIONS cont.

ADDITIONAL RULES FOR SAFE OPERATION cont.

CHAIN BRAKE cont.

2. **PUSH** hand guard forward to activate the chain brake **MANUALLY**. **RELEASE** the trigger switch to activate chain brake **AUTOMATICALLY**. **IMPORTANT:** Please see page 21, figures 8 and 9 for detailed instructions.

⚠ WARNING: • Tip contact in some cases may cause a lightning fast REACTION, kicking the guide bar up and back toward the operator.
• Pinching the saw chain along the tip of the guide bar may push the guide bar rapidly back towards the operator.
• Either of these reactions may cause you to lose control of the saw which could result in serious injury. Do not rely exclusively upon devices built into your saw.

⚠ CAUTION: Exposure to vibrations through prolonged use of hand tools could cause blood vessel or nerve damage in the fingers, hands, and joints of people prone to circulation disorders or abnormal swelling. Prolonged use in cold weather has been linked to blood vessel damage in otherwise healthy people. If symptoms occur such as numbness, pain, loss of strength, change in skin color or texture, or loss of feeling in the fingers, hands, or joints, discontinue the use of this tool and seek medical attention. An anti-vibration system does not guarantee the avoidance of these problems. Users who operate power tools on a continual and regular basis must closely monitor their physical condition and the condition of this tool.

SAVE THESE INSTRUCTIONS. Refer to them frequently and use them to instruct others who may use this tool. If someone borrows this tool, make sure they have these instructions also.

UNPACKING

1. The **Chain Saw** comes fully assembled, including the **Chain/Chain Bar Assembly**.
2. Included is an extra Chain.
3. Remove the **Chain Saw** from the carton. Inspect your Chain Saw.
4. Do not discard box or packing material until all parts are examined.
5. Remove **Plastic Protective Chain and Bar Cover** before use.

NOTE: Chain and Bar Oil is not included. **BEFORE** using this Chain Saw, do not forget to purchase Craftsman Bar & Chain Oil, SAE30.

⚠ WARNING: If any part of the Chain Saw is missing or damaged, do not connect the Chain Saw to the power source until the damaged part is repaired or replaced.

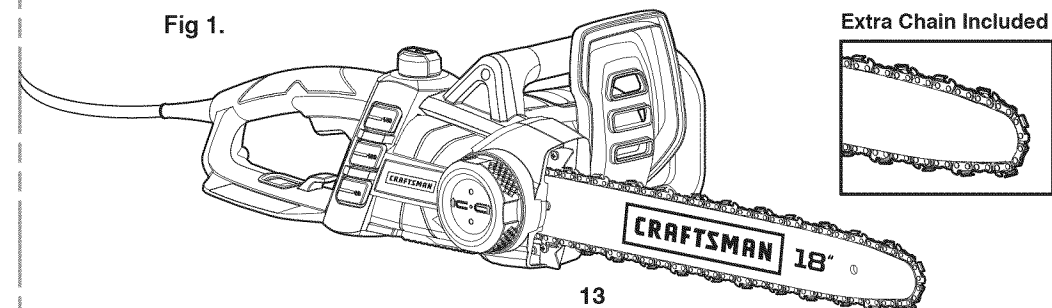

DESCRIPTION

KNOW YOUR CHAIN SAW

NOTE: Before attempting to use this product, familiarize yourself with all operating features and safety rules.

Your Chain Saw has a precision built electric motor and it should only be connected to a **120-volt, 60 Hz AC ONLY** power supply (normal household current). The electric Chain Saw should always be used with a GFCI (Ground Fault Circuit Interrupter) outlet.

DO NOT operate this Chain Saw on direct current (DC). The large voltage drop would cause a loss of power and the motor would overheat.

If the Chain Saw does not operate when plugged into correct 120-volt, 60 Hz AC ONLY outlet, check the power supply. The Chain Saw comes with an electric plug and should be plugged into a proper extension cord (See page 6).

CHAIN SAW FEATURES:

- Power: 4.0 HP, 15 Amp motor
- Bar length: 18"
- Chain brake – Auto and manual
- Automatic lubrication system
- 2 in 1 Tool-less chain tension and blade change with over tensioning protection
- Large oil tank with visible gauge
- Oregon® chain and bar
- Extra chain – non-Oregon®
- Front metal bumper
- Weight 11.68 LBS (when filled with oil)

TECHNICAL DATA:

- Voltage: 120V
- Rated power: 4.0 HP, 15 Amp
- Bar length: 18"
- Chain speed: 12m/s
- Oil tank capacity: 200ml
- Chain pitch: 3/8"
- Number of chain links: 63
- Chain gauge: 0.05"
- Saw chain type: Oregon®, 18" (91PX063X)
Extra chain: E&S, ES91VS63E
- Bar type: Oregon®, 18" (180SDEA041)
- Weight (chain & bar included): 10.5 lbs
- Protection class: □/II

CHAIN SAW CALL-OUTS (See Figures 2 and 3 on page 15)

1. Rear handle (See Fig. 2)
2. On/Off switch (See Fig. 2)
3. Lock-off button (See Fig. 2)
4. Oil filler cap (See Fig. 2)
5. Front handle (See Fig. 2)
6. Activation lever for kickback brake (front Hand Guard) (See Fig. 2)
7. Chain Guide bar (See Fig. 2)
8. Chain (See Fig. 2)
9. Spiked bumper (See Fig. 2)
10. Plastic Chain/Bar/Blade protection cover (See Fig. 2)
11. Locking knob/ Chain tensioning adjustment knob (See Fig. 2)
12. Cover plate (See Fig. 2)

13. Drive sprocket (See Fig. 3)
14. Guide fins for chain bar (See Fig. 3)
15. Symbol for rotation and cutting direction (See Fig. 3)
16. Chain tensioning catch (See Fig. 3)
17. Chain catcher (See Fig. 3)
18. Fastening bolt (See Fig. 3)
19. Oil level gauge (See Fig. 3)

DESCRIPTION cont.

KNOW YOUR CHAIN SAW cont.

CHAIN SAW CALL-OUTS cont. (Figures 2 and 3)

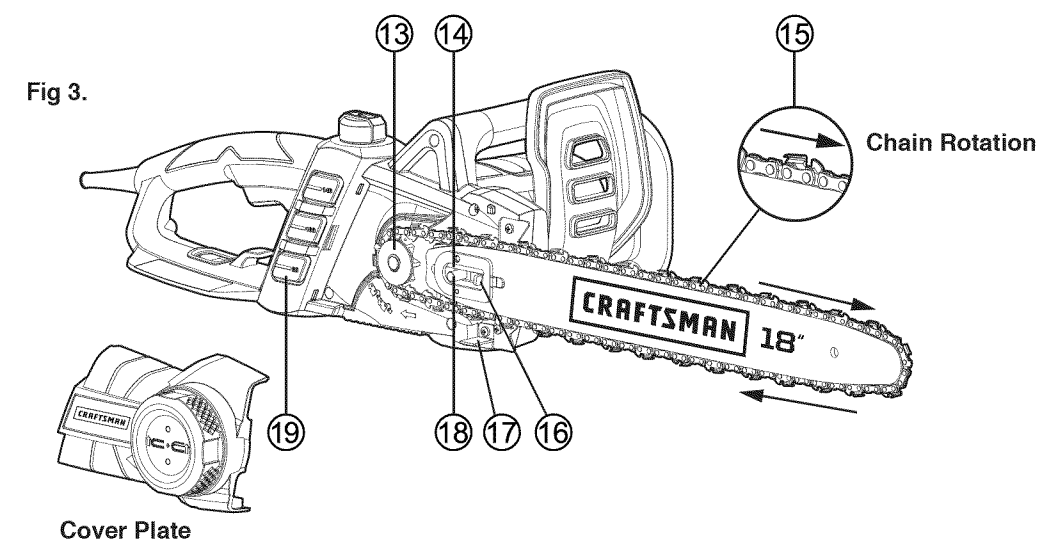
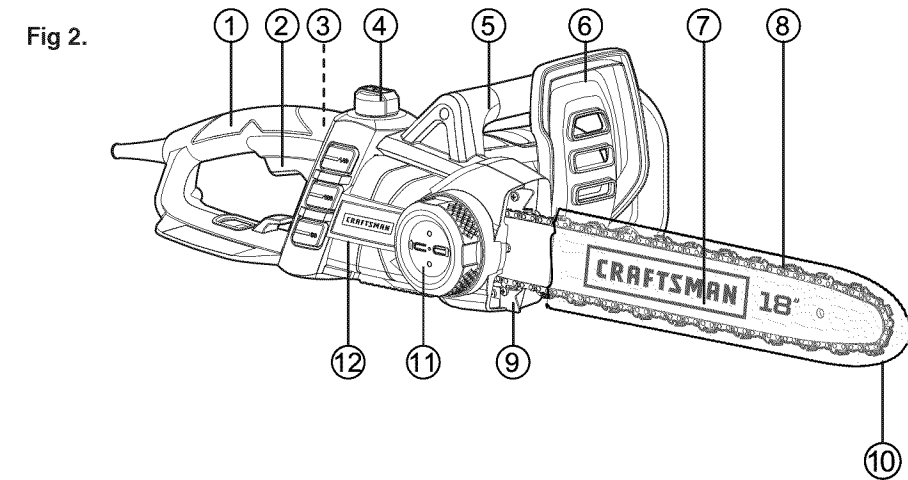

ASSEMBLY & ADJUSTMENTS

INTENDED USE

The chain saw is intended for wood: sawing of trees, tree trunks, branches, wooden beams, planks, etc. Cuts can be sawed with or across the grain. This product is not suitable for sawing mineral materials, plastics or non-wood building materials.

ASSEMBLY

NOTE: This Chain Saw comes fully assembled, including the Chain/Chain Bar Assembly. Included is an extra Chain. See below for Chain/Chain Bar Replacement.

⚠ WARNING: Do not connect the chain saw to extension cord and power source before it is completely assembled. Always use gloves when handling the chain.

CHAIN AND CHAIN BAR ASSEMBLY/REPLACEMENT (See Figs. 4a, 4b, 4c, 4d and Pgs 14-15 for part reference)

1. Place the chain saw on any suitable flat surface.
2. (See Fig. 4a) Slide the chain (8) in the slot around the guide bar (7). Ensure chain is in correct running direction by comparing with chain symbol (15). Ensure the chain tensioning catch (16) is facing outwards.
3. (See Fig. 4b) Fit the chain onto the drive sprocket (13) and guide the guide bar (7), so that the fastening bolt (18) and the two guide fins (14) fit into the keyway of the guide bar (7).

Fig. 4a

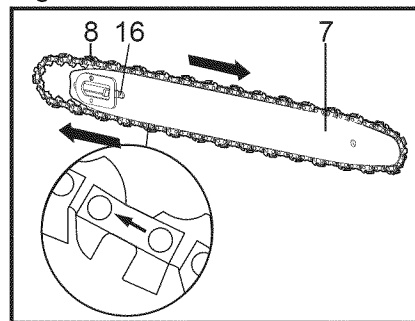

4. Check to make sure all parts are seated properly and hold chain and guide bar in a level position. (See Fig. 4c)
5. Fit cover plate, ensure that the chain catcher (17) fits into the groove of the cover plate (12). (See Figs. 2 & 3, pg.15)
6. Press the cover plate firmly onto the machine and screw on the cover plate (12) with the locking knob (11). (See Fig. 2, pg.15)

NOTE: The chain is not yet tensioned. Tensioning the chain applies as described under "Tensioning chain".

Fig. 4b

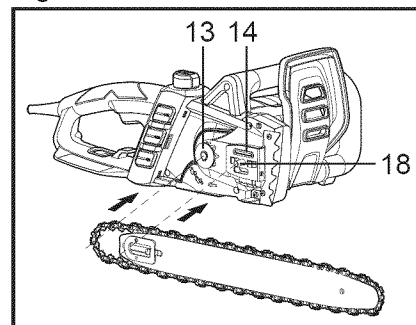
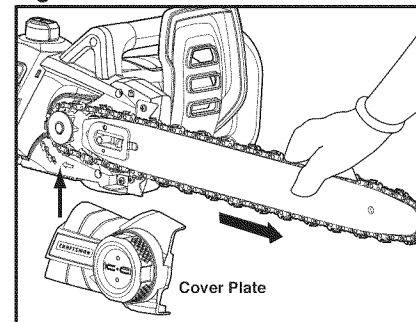

Fig. 4c



16

ASSEMBLY & ADJUSTMENTS cont.

TENSIONING CHAIN/LOCKING KNOB

Always check the chain tension before use, after the first cuts and regularly during use. Upon initial operation, new chains can lengthen considerably.

⚠ WARNING: Unplug chain saw from power source before adjusting saw chain tension.

⚠ WARNING: Cutting edges on chain are sharp. Use protective gloves when handling chain.

⚠ WARNING: ALWAYS Maintain proper chain tension. A loose chain will increase the risk of kickback. A loose chain may jump out of guide bar groove. This may injure operator and damage chain. A loose chain will cause chain, chain bar, and sprocket to wear rapidly. The chain life of the saw chain mainly depends upon sufficient lubrication and correct tensioning. Avoid tensioning the chain if it is hot, as this will cause the chain to become over tensioned when it cools down.

Fig. 4d

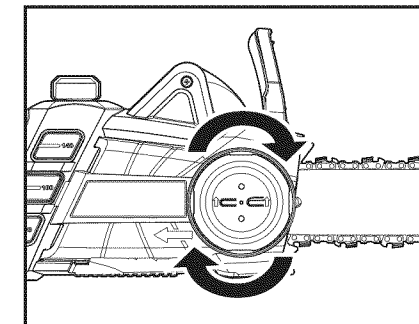

1. Place the chain saw on any suitable flat surface.
2. Turn the locking knob/ chain tensioning knob clockwise until the locking knob is screwed tightly, (See Fig. 4d). The correct chain tension will be reached automatically. The ratchet mechanism prevents the chain tension from loosening.
3. The correct chain tension is reached when the chain can be raised **approx.** 3-6 mm (1/8 to 1/4-in.) from the chain bar in the centre. This should be done by using one hand to raise the chain against the weight of the machine. (See Fig. 5)
4. When the chain looses, unscrew the locking knob/chain tensioning knob absolutely and then Screw on the cover plate with the locking knob tightly again.

Fig. 5

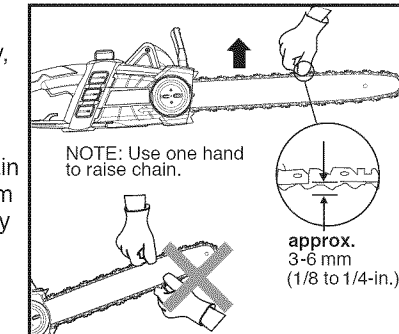

17

ASSEMBLY & ADJUSTMENTS cont.

LUBRICATION

CAUTION: The chain saw is **NOT** supplied filled with oil. It is essential to fill with oil before use. Never operate the chain saw without chain oil or at an empty oil tank level, as this will result in extensive damage to the product. Chain life and cutting capacity depends on optimum lubrication. Therefore, the chain is automatically oiled during operation via oil outlet

Filling oil tank: (See Fig. 6)

1. Set chain saw on any suitable surface with oil filler cap facing upward.
2. Clean area around the Oil Filler Cap with cloth and unscrew the cap by turning it counter clockwise.
3. Add bar and chain oil (Craftsman Bar & Chain Oil, SAE30) until reservoir is full.
4. Avoid dirt or debris entering oil tank, re-screw oil filler cap and tighten.

Fig. 6

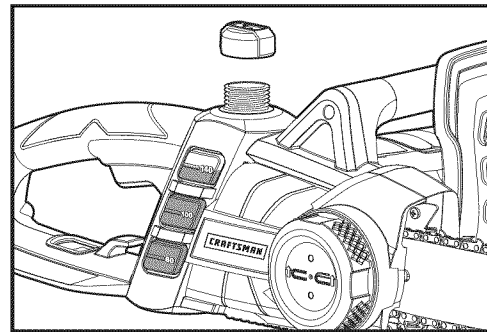

CAUTION: To allow venting of the oil reservoir, small breather channels are provided between the oil filler cap and the strainer. To prevent leakage, ensure machine is left in a horizontal position (oil filler cap uppermost) when not in use. It is important to use only the recommended oil to avoid damage to the chain saw. Never use recycled/old oil. Use of non approved oil will invalidate the warranty.

CHAINSAW OPERATION TERMS

Bucking – The process of cross cutting a felled tree or log into lengths.

Chain Stop Lever – A device used to stop the chain saw.

Chain Saw Power Head – A chain saw without the saw chain and guide bar.

Drive Sprocket or Sprocket – The toothed part that drives the saw chain.

Felling – The process of cutting down a tree.

Felling Back Cut – The final cut in a tree felling operation made on the opposite side of the tree from the notching undercut.

Front Handle – The support handle located at or toward the front of the chain saw.

Front Hand Guard – A structural barrier between the front handle of a chain saw and the guide bar, typically located close to the hand position on the front handle and sometimes employed as an activating lever for a chain brake.

Guide Bar – A solid railed structure that supports and guides the saw chain.

Kickback – The backward or upward motion, or both of the guide bar occurring when the saw chain near the nose of the top area of the guide bar contacts any object such as a log or branch, or when the wood closed in the pinches the saw chain in the cut.

Kickback, Pinch – The rapid pushback of the saw which can occur when the wood closes in and pinches the moving saw chain in the cut along the top of the guide bar.

Kickback, Rotational – The rapid upward and backward motion of the saw which can occur when the moving saw chain near the upper portion of the tip of the guide bar contacts an object, such as a log or branch.

Low-Kickback Chain – A chain that complies with the kickback performance requirements of ANSI B175.1-1991 when tested on a representative sample of chain saws.

Normal Cutting Position – Those positions assumed in performing the bucking and felling cuts.

Notching Undercut – A notch cut in a tree that directs the tree's fall.

Oiler Control – A system for oiling the guide bar and saw chain.

Rear Handle – The support handle located at or toward the rear of the saw.

Reduced Kickback Guide Bar – A guide bar which has been demonstrated to reduce kickback significantly.

Replacement Saw Chain – A chain that complies with the kickback performance requirements of ANSI B175.1-1991 when tested with specific chain saws. It may not meet the ANSI performance requirements when used with other saws.

Saw Chain – A loop of chain having cutting teeth, that cut the wood, and that is driven by the motor and is supported by the guide bar.

Spiked Bumper (Gripping Teeth) – The pointed tooth or teeth for use when felling or bucking to pivot the saw and maintain position while sawing.

Switch – A device that when operated will complete or interrupt an electrical power circuit to the motor of the chain saw.

Switch Linkage – The mechanism that transmits motion from a trigger to the switch.

Lock-off Button – A movable stop that prevents the unintentional operation of the switch until manually actuated.

OPERATION

ATTACHING EXTENSION CORD

1. Remove Plug safety cap as shown (Fig. 7a). Insert extension cord socket into Chain Saw's Plug (Fig. 7b).
2. An Extension Cord Retainer is attached to the Handle to reduce strain on the cord. To use this feature, simply double the extension cord as shown, about a foot from the end, and insert it into the end of the Retainer. Place the loop formed by doubling the cord over the Hook (Fig. 7c). Gently tug on the cord to ensure that it is firmly situated in the Retainer (Fig. 7d).
3. Keep extension cord clear of operator, unit and any obstacles at all times. Do not expose the cord to heat, oil, water, or sharp edges.

Fig. 7a

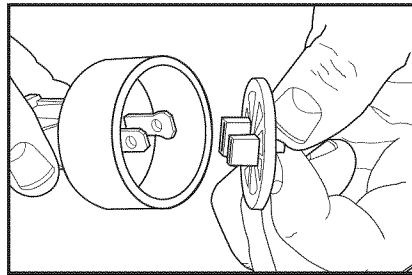

Fig. 7b

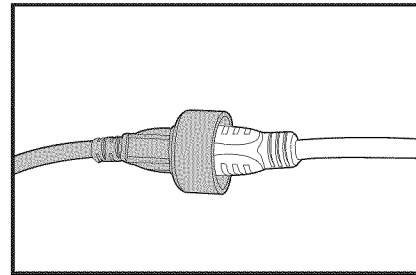

Fig. 7c

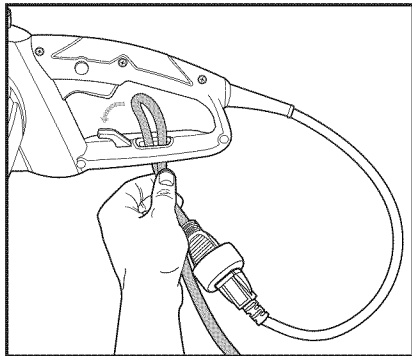
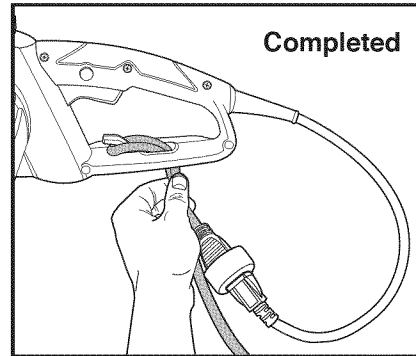

Fig. 7d



Cord locked in Extension Cord Retainer

OPERATION cont.

SWITCHING ON AND OFF (Fig. 8)

⚠ WARNING: Check the voltage and electric current supply: The voltage and current supply must comply with the ratings on the data plate.

1. To switch the Chain Saw ON, press the **lock-off button**, then fully press the **on/off switch (2)** and hold in this position. The lock-off button (3) can now be released.
2. To switch the Chain Saw OFF, release the **on/off switch (2)**. Do not stop chain saw after sawing by activating the front hand guard (manual chain brake).

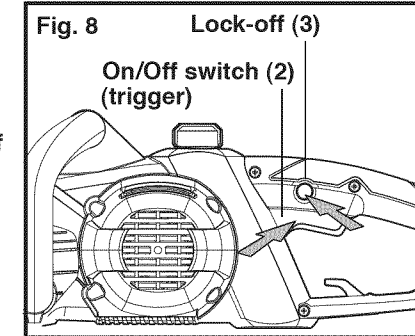

THE CHAIN BREAK (Built-In, Manual and Automatic and Systems) (Figs. 8 and 9)

The MANUAL chain brake is a safety mechanism activated through the front hand guard (5) when kickback occurs. Chain stops immediately.

The following function check should be carried out at regular intervals.

1. **MANUAL CHAIN BRAKE (See Fig. 9): PUSH** front hand guard (5) forward (position 2) and try starting the chain saw. **The chain must not start.** To deactivate the kickback brake, pull hand guard (5) backwards (position 1), and release On/Off (trigger) switch (2), (See Fig. 8 for On/Off switch location).
2. **AUTOMATIC CHAIN BRAKE: RELEASE** the On/Off (trigger) switch to activate chain brake **AUTOMATICALLY**, (See Fig. 8 for On/Off switch location).

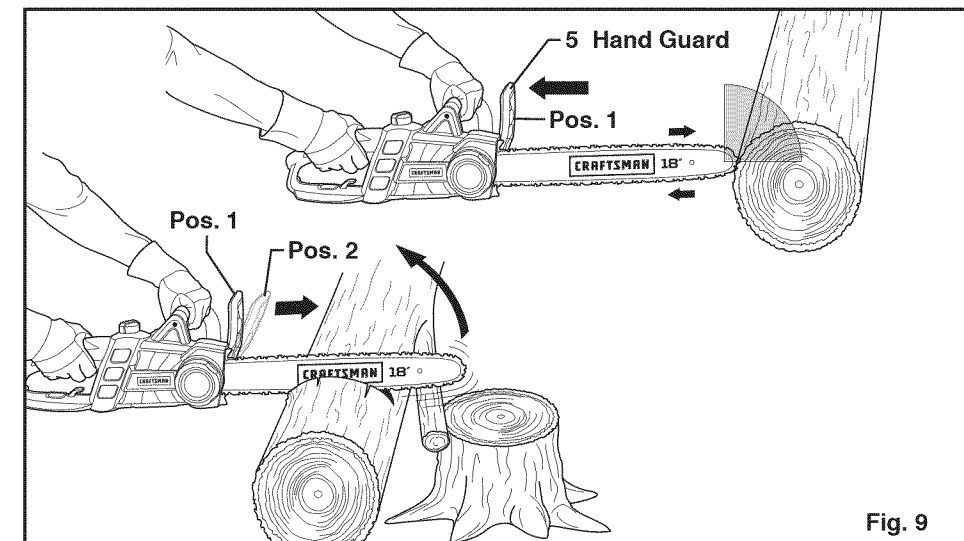

OPERATION cont.

CUTTING

Check oil level gauge prior to starting and regularly during operation. Refill oil when oil level is low. The oil tank filling will last approx. 16 minutes, depending on sawing intensity and stops. (See Fig. 6 on page 18)

Confirm the chain tension is in working order and the chain sharp.
Check new replaced chain tension during operation.

Upon initial operation, new chains can lengthen considerably. The condition of the chain influences the cutting performance. Only a sharp chain protects from overload.

Make sure you are wearing the necessary protective equipment.

Wear safety glasses/goggles/visor – safety helmet and hearing protection.

Further protective equipment for head, hands, legs and feet is highly recommended.

Adequate protective clothing will reduce personal injury by flying debris or accidental contact with saw chain.

Proper functioning of the automatic oiler can be checked by running the chain saw and pointing the tip of the chain bar towards a piece of cardboard or paper on the ground.

CAUTION: Do not touch the ground with the chain. Ensure safety clearance of 20 cm. (7-7/8 inch.) If an increasing oil pattern develops, the automatic oiler is operating fine. If there is no oil pattern, despite a full oil reservoir, see "Troubleshooting".

KICKBACK (Fig. 10a, 10b)

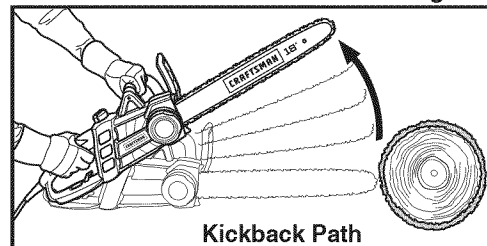

Fig. 10a

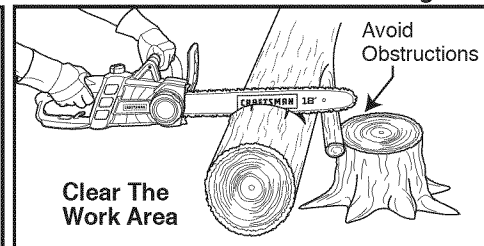

Fig. 10b

KICKBACK is the backward, upward or sudden forward motion of the guide bar occurring when the saw chain near the upper tip of the guide bar contacts any object such as a log or branch, or when the wood closes in and pinches chain in the cut. Contacting a foreign object in the wood can also result in loss of chain saw control.

When kickback occurs the chainsaw reacts unpredictably and can cause severe injuries to the operator or bystanders. Particular attention must be given when sawing sideward, slanted or during length cuts, as the spiked bumper usually can not be applied.

To avoid kickback:

- Saw with guide bar at a flat angle.
- Never work with a loose, widely stretched or the heavily worn out chain.
- Ensure chain is sharpened correctly.
- Never saw above shoulder height.
- Never work with the tip of the guide bar.
- Always hold the chain saw firmly with both hands.
- Always use a low kickback chain.
- Apply the metal gripping teeth for leverage.
- Ensure correct chain tension.

OPERATION cont.

GENERAL CUTTING

Always hold the chain saw firmly with both hands. Front grip with the left hand and rear grip with the right hand. Fully grip both handles at all times during operation. (See Figs. 11 and 12)

Never operate chain saw using only one hand. Ensure power cord is located to the rear, away from the chain and wood and so positioned that it will not be caught on branches or the like during cutting. (see **THE CHAIN BREAK**, page 21)

Fig. 11

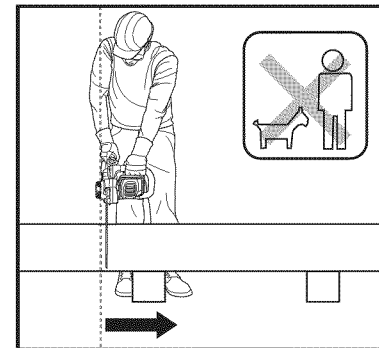
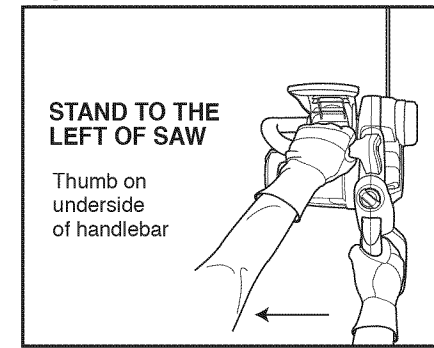

Fig. 12



Use the chain saw only with secure footing.

Hold the chain saw at the right-hand side of your body. (See Figs. 11 and 12)

The chain must be running at full speed before it makes contact with the wood.

Use the metal gripping teeth to secure the saw onto the wood before starting to cut.

Use the spiked bumper (9) as a leverage point while cutting. (See Fig. 13)

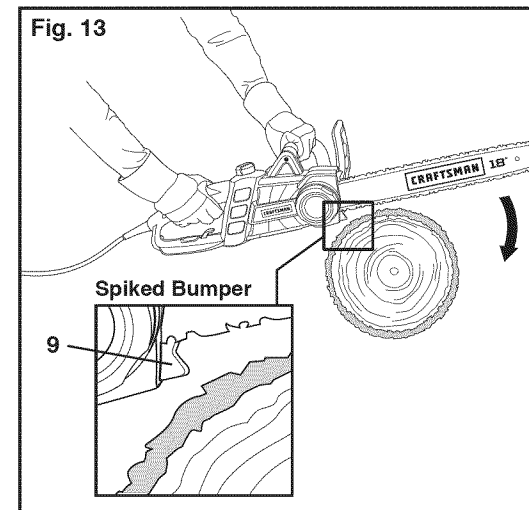

OPERATION cont.

GENERAL CUTTING cont.

Reset the gripping teeth at a low point when sawing thicker logs by pulling the chain saw slightly backwards until the gripping teeth release, and reposition at lower level to continue sawing. (See Fig. 13)

- Do not remove the saw completely from the wood.
- Do not force the chain while cutting, let the chain do the work, using the gripping teeth to apply minimal leverage pressure.
- Do not operate the chain saw with arms fully extended or attempt to saw areas which are difficult to reach, or on a ladder. Never use the chain saw above shoulder height. (See Fig. 14)

NOTE: Sawing is optimized when the chain speed remains steady during cutting.

Beware when reaching the end of the cut. The weight of the saw may change unexpectedly as it cuts free from the wood.

Accidents can occur to the legs and feet.

Always remove the saw from a wood cut while the saw is running.

NOTE: Do not attempt a pruning or limbing operation in a standing tree unless specifically trained to do so.

NOTE: When cutting a limb that is under tension or compression, be alert for springback.

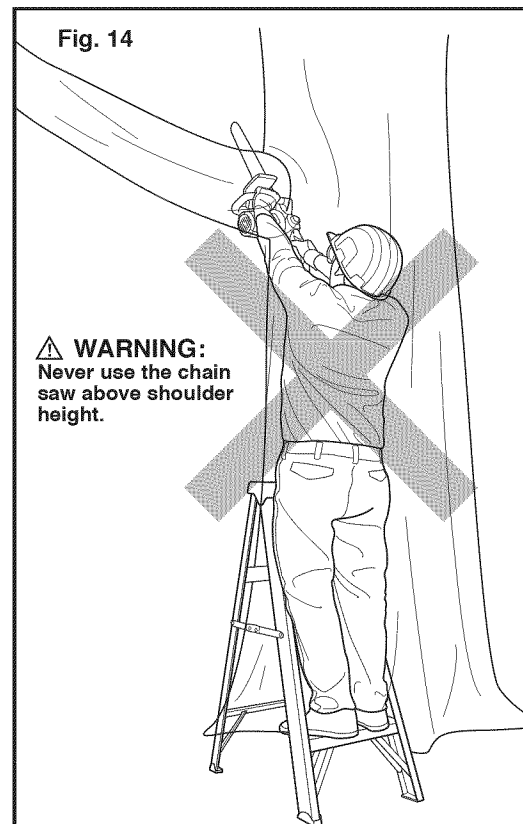

Fig. 14

WARNING:
Never use the chain saw above shoulder height.

OPERATION cont.

GENERAL CUTTING cont.

CUTTING LOGS

Observe the following safety instructions:

Support logs so that the face sides at the cut do not close in against each other, which would result in the chain being jammed or pinched. (See Figs. 15 and 16)

Fig. 15

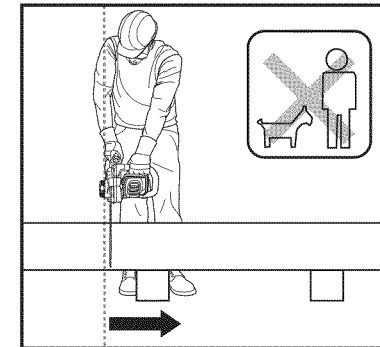
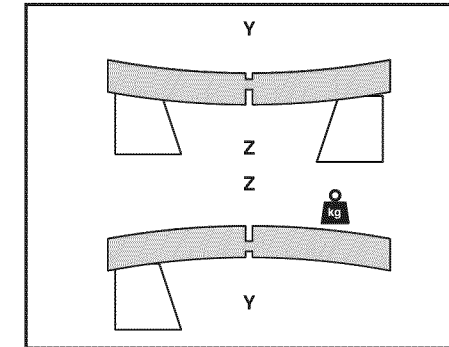

Fig. 16



CAUTION:

Position and set short logs safety prior to sawing. Saw only wood or wooden objects. When sawing, always take care to avoid hitting stones, nails, ect, as these could be thrown up or cause damage to the chain or serious injury to the operator or bystanders.

Keep a running saw clear of wire fencing or the ground.

Use of the saw to thin out branches or bushes is not approved.

Length cuts must be carried out with care, as leverage with the spiked bumper is not possible. Saw at a flat angle to avoid kickback.

When working on a slope, operate above or to the side of the trunk or laying tree.

Be careful not to trip over tree stumps, branches, roots, etc.

CUTTING WOOD UNDER TENSION (See Fig. 16)

There is a high risk of accidents when sawing wood, branch or trees under **tension**.

Be extremely careful. Leave saw jobs like these to professionals.

When sawing logs supported on both ends, start the cut from above (Y) about 1/3 of the diameter into the log and then finish the cut (Z) from below, in order to avoid contact of the chain saw with the ground. When sawing logs supported on only one end, start the cut from below (Y) about 1/3 of the diameter into the log and finish the cut from above (Z) in order to avoid log splitting or jamming of the chain saw.

OPERATION cont.

GENERAL CUTTING cont.

FELLING TREES (See Fig. 17)

Always wear hard hat to protect head against falling branches.
The chain saw can only be used to fell trees smaller in diameter than the length of the guide bar.

- 1. Secure work area (See 1, Fig. 17).** Ensure no persons or animals are in the vicinity of the falling tree. Never attempt to free a jammed saw with the motor running. Use wooden wedges to free chain and guide bar.
When cutting and felling operations are being performed by two or more persons, at the same time, the felling operations should be separated from the cutting operation by a distance of at least twice the height of the tree being felled. Trees should not be felled in a manner that would endanger any person, strike any utility line or cause any property damage. If the tree does make contact with any utility line, the company should be notified immediately.
The chain saw operator should keep on the uphill side of the terrain as the tree is likely to roll or slide downhill after it is felled.
- 2. An escape path (See 2, Fig. 17)** should be planned and cleared as necessary before cuts are started. The escape path should extend back and diagonally to the rear of the expected line of fall.
- 3. Before felling is started (See 3, Fig. 17),** consider the natural lean of the tree, the location of larger branches and the wind direction to judge which way the tree will fall. Remove dirt, stones, loose bark, nails staples, and wire from the tree.

Notching undercut: Make the notch (x-w) 1/3 the diameter of the tree, perpendicular to the direction of falls as make the lower horizontal notching cut first. This will help to avoid pinching either the saw chain or the guide bar when the second notch is being made.

Felling back cut: Make the felling back cut (Y) at least 50 mm (2-Inches) higher than the horizontal notching cut. Keep the felling back cut parallel to the horizontal notching cut.

Make the felling back cut so enough wood is left to act as a hinge. The hinge wood keeps the tree from twisting and falling in the wrong direction. Do not cut through the hinge. As the felling gets close to the hinge the tree should begin to fall. If there is any chance that the tree may not fall in desired direction or it may rock back and bind the saw chain, stop cutting before the felling back cut is complete and use wedges of wood, plastic, or aluminum to open the cut and drop the tree along the desired line of fall.

When the tree begins to fall remove the chain saw from the cutting, stop the motor, put the chain saw down, and then use the retreat path planned. Be alert for overhead limbs falling and watch your footing.

To complete the felling operation, drive a wedge (Z) into the horizontal cut. **BEWARE** of falling branches when the tree starts to move.

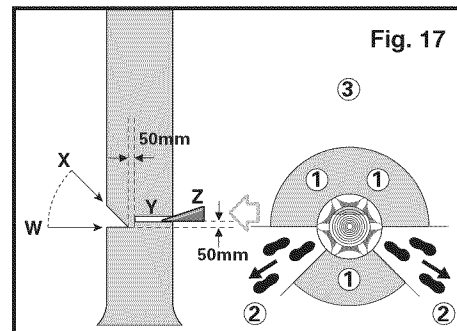

OPERATION cont.

GENERAL CUTTING cont.

LIMBING A TREE (See Fig. 18)

Limbing is removing the branches from a fallen tree. When limbing leave larger lower limbs to support the log off the ground.

Remove the small limbs in one cut as illustrated. Branches under tension should be cut from the bottom up to avoid binding the chain saw.

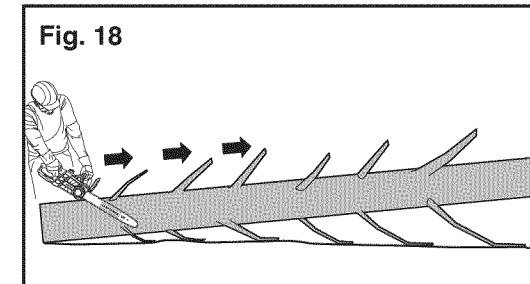

BUCKING A LOG (See Fig. 19)

Bucking is cutting a log into lengths. It is important to make sure your footing is firm and your weight is evenly distributed on both feet. When possible, the log should be raised and supported by the use of limbs, logs or chocks.

Follow the simple directions for easy cutting.

When the log is supported along its entire as illustrated, it is cut from the top (overbuck).

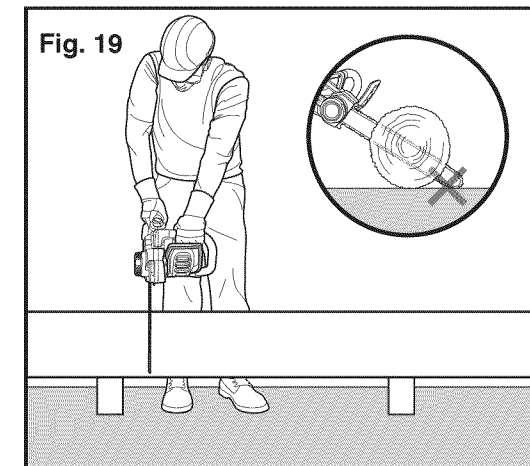

When the log is supported on one end, as illustrated, cut 1/3 the diameter from the underside (underbuck).

Then make the finished cut by overbucking to meet the first cut. (See Fig. 21)

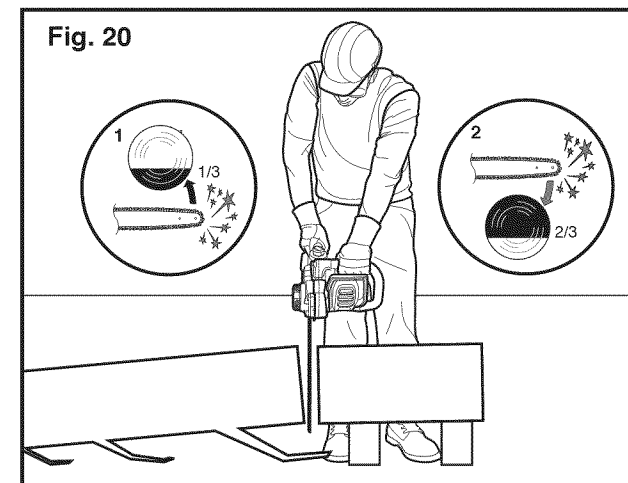

OPERATION cont.

GENERAL CUTTING cont.

BUCKING A LOG cont.

When the log is supported on both ends, as illustrated, cut 1/3 the diameter from the top overbuck. Then make the finished cut by underbucking the lower 2/3 to meet the first cut. (See Fig. 21)

When bucking on a slope always stand on the uphill side of the log, as illustrated.

When "cutting through", to maintain complete control release the cutting pressure near the end of the cut without relaxing your grip on the chain saw handles.

Don't let the chain contact the ground.

After completing the cut, wait for the saw chain to stop before you move the chain saw.

Always stop the motor before moving from tree to tree. (See Fig. 22)

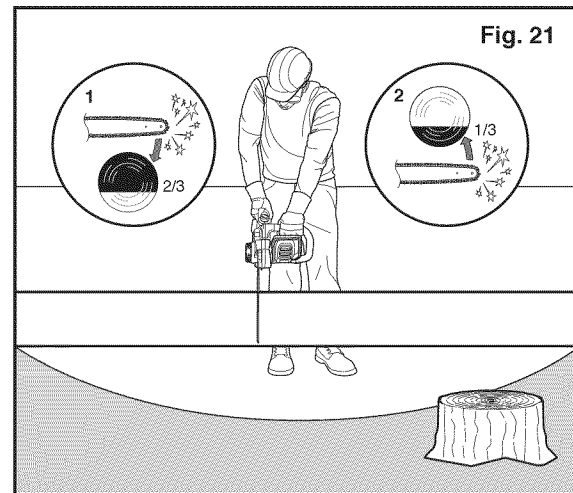

Fig. 21

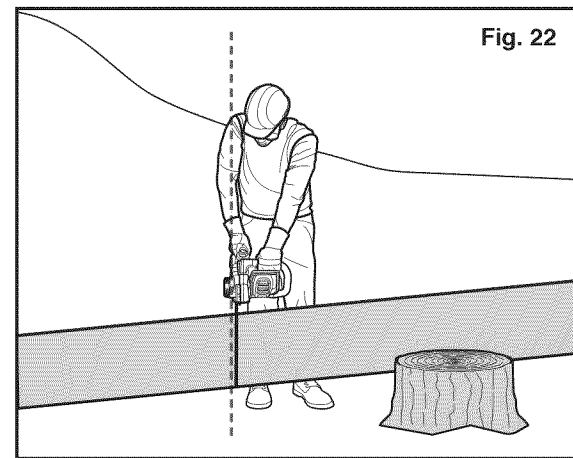

Fig. 22

MAINTENANCE

GENERAL MAINTENANCE

⚠ WARNING: Before performing any work on the Chain Saw, disconnect the Chain Saw's power plug from the extension cord and power source.

NOTE: To ensure long and reliable service, carry out the following maintenance regularly and before each use:

Regularly check for obvious defects such as loose, dislodged or damaged chain and guide bar, loose fixings and worn or damaged components. Inspect the switch and cord for damage. Check that covers and guards are undamaged and correctly fitted.

⚠ WARNING: DO NOT use the Chain Saw if it has any broken parts. ALWAYS have damaged, missing, worn or broken parts replaced before using.

NOTE: WHEN SERVICING a tool, use only identical replacement parts. Use of unauthorized parts or failure to follow maintenance instructions may create a risk of electric shock or injury.

Carry out necessary maintenance or repairs before using the chain saw. If the chain saw should happen to fail despite the care taken in manufacturing and testing, repair should be carried out by an authorized, qualified service dealer or repair center. Before returning, ensure all oil in the oil tank has been emptied.

Replacing/Changing Chain And Guide Bar

Fit the chain and guide bar as described in "Assembly and Tensioning Chain", (See pages 16 and 17). The circular groove of the guide bar will wear particularly on the lower edge with time. When replacing the chain turn the chain bar 180° to allow even wear, thus extending chain bar life.

Check Drive Sprocket. If it is worn out or damaged due to strain, have it exchanged by an authorized service dealer.

If The Chain Bar Is Worn Out Or Damaged, take the chain tensioning catch off the bar by loosening the screw counter-clockwise. Then fit the tensioning catch into the new bar by tightening the screw clockwise. The catch protrude (1) must be fitted into the bar hole. (See Fig. 23)

Sharpening Chain. Have your chain sharpened professionally at your approved service dealer or repair center or sharpen the chain yourself using the sharpening kit. Follow the sharpening instructions supplied with the sharpening kit.

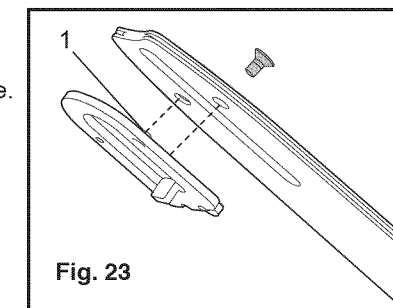

Fig. 23

CLEANING / STORAGE

GENERAL MAINTENANCE cont.

- Clean the moulded plastic housing of the chain saw using a soft brush and clean cloth. **DO NOT** use water, solvents or polishes.
- Remove all debris, especially from the motor cooling vents.
- Remove and brush clean the cover plate, chain and chain bar after 1 to 3 hours of use.
- Clean the area under the cover plate, the drive sprocket and chain bar assembly using a soft brush.
- Clean oil outlet with a clean cloth.
- If the chain saw is to be stored for a longer period of time, clean chain and chain bar.

STORE IN A SECURE, DRY PLACE OUT OF THE REACH OF CHILDREN.

- Do not place other objects on the chain saw.
- To prevent oil leakage, ensure machine is left in a horizontal position.
- When storing machine in original packaging the oil tank must be completely emptied.

TROUBLE SHOOTING

SYMPTOM	POSSIBLE	CAUSE
Chain saw fails to operate	Kickback brake is activated No power Mains socket faulty Extension cord damaged Fuse faulty	Pull hand guard back in position 1 (See Figure 9) Check power Use another socket Check cord, replace Replace fuse
Chain saw operates intermittently	Extension cord damaged Loose connection Internal wiring defective On/Off defective	Check cord, replace Contact service agent Contact service agent Contact service agent
Dry chain	No oil in reservoir Vent in oil filler cap clogged Oil passage clogged	Refill oil Clean cap Clean oil passage outlet
Kickback Brake/Run Down Brake	Brake does not stop chain	Contact service agent
Chain/chain bar overheats	No oil in reservoir Vent in oil filler cap clogged Oil passage clogged Chain is over tensioned Dull chain	Refill oil Clean cap Clean oil passage outlet Adjust locking knob Sharpen chain or replace
Chain saw rips, vibrates, does not saw properly	Chain tension too loose Dull chain Chain worn out Chain teeth are facing in the wrong direction	Adjust locking knob Sharpen chain or replace Replace chain Reassemble with chain in correct direction

Never use tools with defective On/Off switches or defective Kickback brake (Hand Guard). In the case of all other types of technical faults, please contact helpline or qualified service dealer or repair center.

SPECIFICATIONS

Model 71-34120

Voltage	120V~60Hz
Amps	15A
Bar length	18"
Chain speed	12m/s
Oil tank capacity	6.76 oz. (200ml)
Chain pitch	3/8"
Number of chain links	63
Chain gauge	0.05"
Chain	Oregon®: 18" (91PX063X)
Extra Chain Included	E&S: ES91VS63E
Bar	Oregon®: 18" (180SDEA041)
Weight (chain & bar included)	10.5 lbs
Protection class	□ / II

NEED MORE HELP?

You'll find the answer and more on managemyhome.com – for free!

- Find this and all your other product manuals online.
- Get answers from our team of home experts.
- Get a personalized maintenance plan for your home.
- Find information and tools to help with home projects.

manage my home

brought to you by Sears

**15 Amp/4.0 Peak HP Motor
Electric Chain Saw**

Model No.
172.34120.00 18-In. Bar

The model number will be found on the nameplate of the Chain Saw.
Always mention the model number when requesting parts and service
for your tool. To order parts, call 1-800-469-4663

PARTS LIST

32

Position No.	Parts No.	Part Description	Qty.
201	GCS450U.1-201	Motor set	1
1	GCS450U.1-1	Nut	2
2	GCS450U.1-2	Torsional Spring	2
3	GCS450U.1-3	Carbon Brush(pair)	1
4	GCS450U.1-4	Rear Bracket	1
5	GCS450U.1-5	Bearing	1
6	GCS450U.1-6	Rotor	1
8	GCS450U.1-8	Bearing	1
9	GCS450U.1-9	Stator	1
10	GCS450U.1-10	Front Bracket	1
11	GCS450U.1-11	Screw	2
12	GCS450U.1-12	Bracket	1
13	GCS450U.1-13	Self Tapping Screw	4
13	GCS450U.1-13	Self Tapping Screw	22
14	GCS450U.1-14	Brake Bracket	1
15	GCS450U.1-15	Switch	1
16	GCS450U.1-16	Pinion	1
17	GCS450U.1-17	Retaining Ring	2
19	GCS450U.1-19	Power Cord	1
20	GCS450U.1-20	Cable Protector	1
21	GCS450U.1-21	Terminal Port	1
22	GCS450U.1-22	Cord Clamp	1
203	GCS450U.1-203	Inner Wire	1
23	GCS450U.1-23	Inner Wire	1
24	GCS450U.1-24	Inner Wire	1
25	GCS450U.1-25	Inner Wire	1
27	GCS450U.1-27	Front Handle Assembly	1

Position No.	Parts No.	Part Description	Qty.
28	GCS450U.1-28	Protect Plate	1
29	GCS450U.1-29	Rated Label	1
30	GCS450U.1-30	Decorative Cover	1
31	GCS450U.1-31	Housing	1
32	GCS450U.1-32	Tube I	1
33	GCS450U.1-33	Rotating Plate	1
34	GCS450U.1-34	Washer	4
35	GCS450U.1-35	Torsional Spring	1
36	GCS450U.1-36	Trigger	1
37	GCS450U.1-37	Button	1
38	GCS450U.1-38	Torsional Spring	1
39	GCS450U.1-39	Oil Bottle Cap	1
40	GCS450U.1-40	Extension Spring	1
204	GCS450U.1-204	Connecting Pole Set	1
41	GCS450U.1-41	Rivet	2
42	GCS450U.1-42	Ring	1
43	GCS450U.1-43	Linkage	1
44	GCS450U.1-44	Extension Spring	1
45	GCS450U.1-45	Belt	1
46	GCS450U.1-46	Duck Bill	1
47	GCS450U.1-47	Rubber Washer	1
48	GCS450U.1-48	Oil Bottle	1
49	GCS450U.1-49	Oil Tube II	1
50	GCS450U.1-50	Self tapping screw	1
205	GCS450U.1-205	Pump Assembly	1
51	GCS450U.1-51	Oil Exit	1
53	GCS450U.1-53	Compression Spring	1

**15 Amp/4.0 Peak HP Motor
Electric Chain Saw**

Model No.
172.34120.00 18-In. Bar

The model number will be found on the nameplate of the Chain Saw.
Always mention the model number when requesting parts and service
for your tool. To order parts, call 1-800-469-4663

PARTS LIST

33

Position No.	Parts No.	Part Description	Qty.
54	GCS450U.1-54	Steel ball	1
55	GCS450U.1-55	O Ring	1
56	GCS450U.1-56	Pump Housing	1
57	GCS450U.1-57	Pump	1
58	GCS450U.1-58	O Ring	1
59	GCS450U.1-59	Washer	1
60	GCS450U.1-60	Compression Spring	1
61	GCS450U.1-61	Pump Rod	1
62	GCS450U.1-62	Oil Tube I	1
63	GCS450U.1-63	Tube	1
64	GCS450U.1-64	Washer	1
65	GCS450U.1-65	Self Tapping Screw	1
66	GCS450U.1-66	Chain	1
206	GCS450U.1-206	Guide Bar	1
67	GCS450U.1-67	Self Tapping Screw	1
68	GCS450U.1-68	Guide Bar	1
69	GCS450U.1-69	Press Block	1
70	GCS450U.1-70	Chain Sheath	1
71	GCS450U.1-71	Torsional Spring	1
72	GCS450U.1-72	Tube	1
73	GCS450U.1-73	Rotating Block I	1
74	GCS450U.1-74	Needle Bearing	1
75	GCS450U.1-75	Washer	1
207	GCS450U.1-207	Output Shaft	1
76	GCS450U.1-76	Gear	1
77	GCS450U.1-77	Spindle	1
78	GCS450U.1-78	Washer	1
79	GCS450U.1-79	Bearing	1
80	GCS450U.1-80	Self Tapping Screw	2

Position No.	Parts No.	Part Description	Qty.
82	GCS450U.1-82	Chain Wheel	1
83	GCS450U.1-83	Self Tapping Screw	1
84	GCS450U.1-84	Oil Seal	1
85	GCS450U.1-85	Chain Catcher	1
86	GCS450U.1-86	Ring	1
87	GCS450U.1-87	Spiked Bumper	1
89	GCS450U.1-89	Compression Block	1
90	GCS450U.1-90	Cam	1
91	GCS450U.1-91	Chain Guard Housing	1
92	GCS450U.1-92	Brand Label	1
208	GCS450U.1-208	Clutch Assembly	1
93	GCS450U.1-93	Clutch Drum	1
94	GCS450U.1-94	Compression Spring	1
95	GCS450U.1-95	Clamping Plate	1
96	GCS450U.1-96	Stator Bowl	1
97	GCS450U.1-97	Brake Disc I	1
98	GCS450U.1-98	Brake Disc II	1
99	GCS450U.1-99	Clamping Plate I	1
100	GCS450U.1-100	Self tapping screw	3
101	GCS450U.1-101	Spring	1
209	GCS450U.1-209	Tension Knob	1
102	GCS450U.1-102	Self tapping screw	3
103	GCS450U.1-103	Pwal	3
104	GCS450U.1-104	Tube	3
105	GCS450U.1-105	Torsional Spring	3
106	GCS450U.1-106	Knob	1
107	GCS450U.1-107	Ring I	1
108	GCS450U.1-108	Washer	1
301	GCS450U.1-301	Self Tapping Screw	1

CRAFTSMAN®