

Operator's Manual

CRAFTSMAN®

BROADCAST SPREADER

Model No. 486.24009

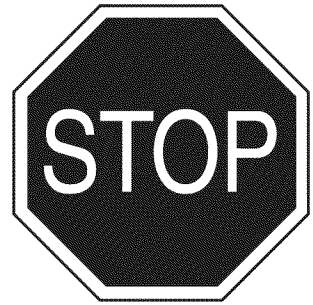

DO NOT RETURN TO STORE
For Missing Parts or Assembly
Questions Call 1-866-576-8388

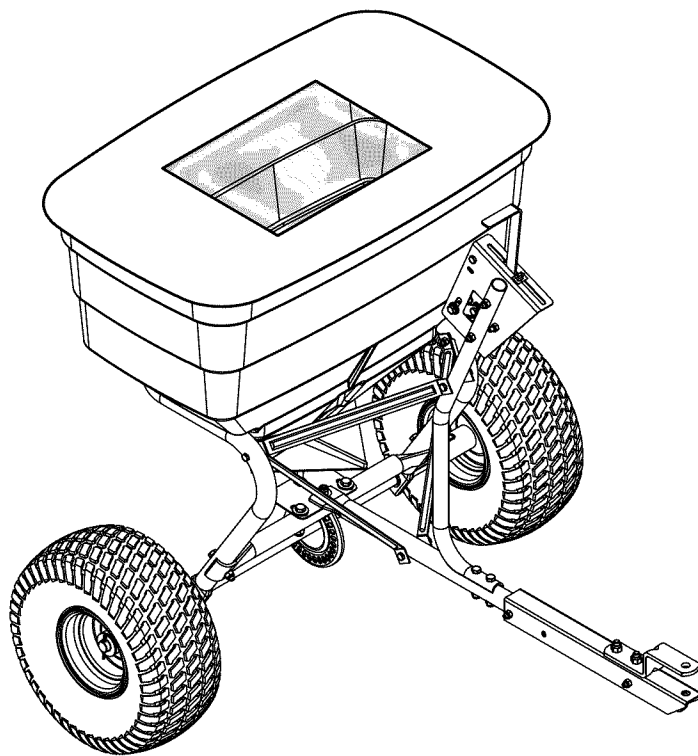

CAUTION:

Before using this product, read this manual and follow all Safety Rules and Operating Instructions.

- Safety
- Assembly
- Operation
- Maintenance
- Parts

Sears Brands Management Corporation, Hoffman Estates, IL 60179 U.S.A.
www.sears.com/craftsman

TABLE OF CONTENTS

WARRANTY 2	MAINTENANCE 9
SAFETY 2	TROUBLESHOOTING..... 9
CARTON CONTENTS 3	REPAIR PARTS ILLUSTRATION..... 10
ASSEMBLY 4	REPAIR PARTS LIST..... 11
OPERATION..... 7	ORDERING REPLACEMENT PARTS..... BACK PAGE

WARRANTY

CRAFTSMAN ONE YEAR FULL WARRANTY

FOR ONE YEAR from the date of purchase, this product is warranted against any defects in material or workmanship. A defective product will be replaced free of charge.

For warranty coverage details to obtain free replacement, visit the web site: www.craftsman.com

This warranty is void if this product is ever used while providing commercial services or if rented to another person.

This warranty gives you specific legal rights, and you may also have other rights which vary from state to state.

Sears Brands Management Corporation, Hoffman Estates, IL 60179

DO NOT RETURN TO STORE for Missing Parts or Assembly Questions

Call 1-866-576-8388 Attachment Hotline

<p>The model number and serial numbers will be found on a decal attached to the [product name].</p> <p>You should record both the serial number and the date of purchase and keep in a safe place for future reference.</p>	<table style="width: 100%; border: none;"> <tr> <td style="padding: 2px 10px 2px 0;">MODEL NUMBER:</td> <td style="padding: 2px 0 2px 10px;">486.24009</td> </tr> <tr> <td style="padding: 2px 10px 2px 0;">SERIAL NUMBER:</td> <td style="padding: 2px 0 2px 10px;">_____</td> </tr> <tr> <td style="padding: 2px 10px 2px 0;">DATE OF PURCHASE:</td> <td style="padding: 2px 0 2px 10px;">_____</td> </tr> </table>	MODEL NUMBER:	486.24009	SERIAL NUMBER:	_____	DATE OF PURCHASE:	_____
MODEL NUMBER:	486.24009						
SERIAL NUMBER:	_____						
DATE OF PURCHASE:	_____						

SAFETY

Remember, any power equipment can cause injury if operated improperly or if the user does not understand how to operate the equipment. Exercise caution at all times when using power equipment.

- Read the towing vehicle owners manual and towing vehicle safety rules. Know how to operate your tractor before using the broadcast spreader attachment.
 - Read the chemical label instructions and cautions for handling and applying the chemicals purchased for spreading.
 - Wear eye and hand protection when handling and when applying lawn or garden chemicals.
 - Never operate tractor and spreader attachment without wearing substantial footwear, and do not allow anyone to ride or sit on spreader attachment frame.
 - Never allow children to operate the tractor or spreader attachment, and do not allow adults to operate without proper instructions.
- Always begin with the transmission in first (low) gear with the engine at low speed, and gradually increase speed as conditions permit.
 - When towing broadcast spreader do not drive too close to a creek or ditch and be alert for holes and other hazards which could cause you to lose control of the broadcast spreader and tractor.
 - Before operating vehicle on any grade (hill) refer to the safety rules in the vehicle owner's manual concerning safe operation on slopes. **Stay off steep slopes!**
 - Follow maintenance and lubrication instructions as outlined in this manual.

LOOK FOR THIS SYMBOL TO POINT OUT IMPORTANT SAFETY PRECAUTIONS. IT MEANS — ATTENTION! BECOME ALERT! YOUR SAFETY IS INVOLVED.

CARTON CONTENTS

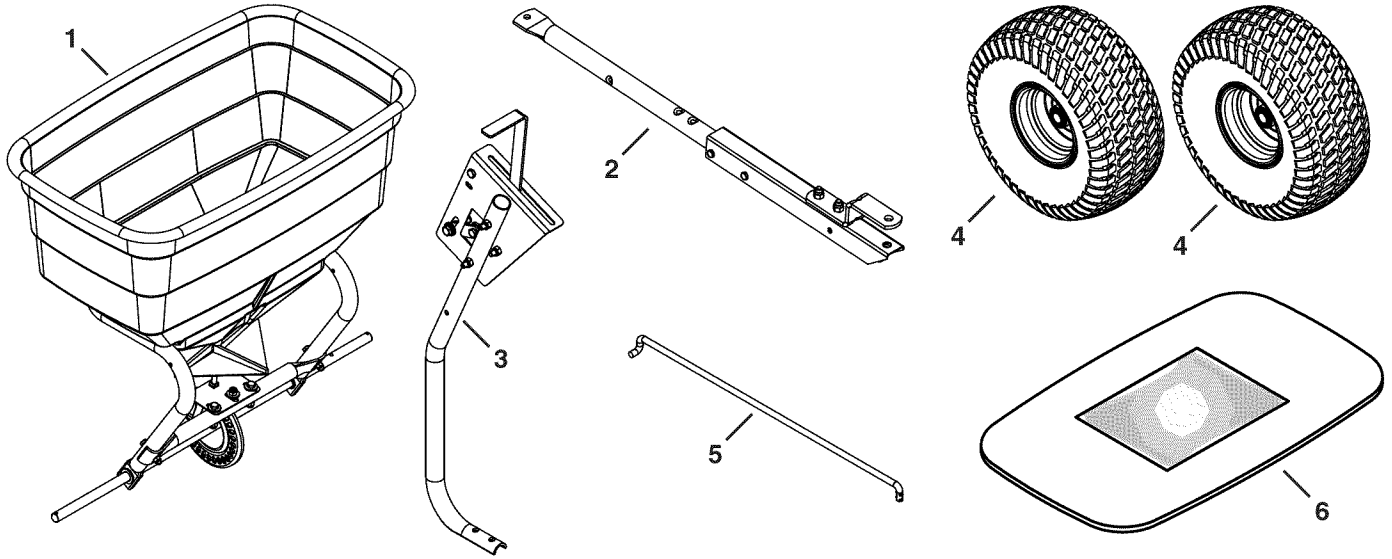

REF	QTY	PART NO	DESCRIPTION	REF	QTY	PART NO	DESCRIPTION
1	1	—	Hopper Assembly	4	2	42493	Wheel
2	1	—	Hitch Tube Assembly	5	1	41549	Flow Control Rod
3	1	—	Flow Control Tube Assembly	6	1	40825	Hopper Cover

HARDWARE PACKAGE

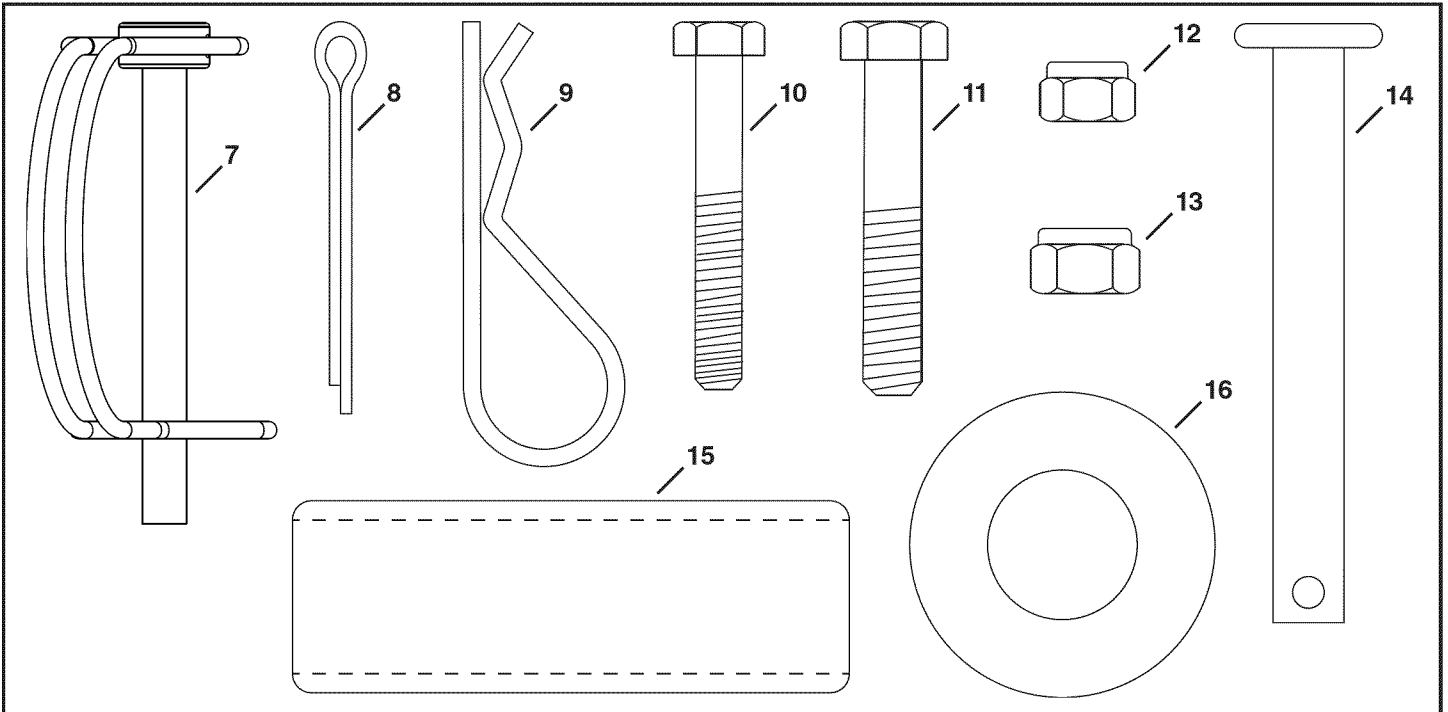

REF	QTY	PART NO	DESCRIPTION	REF	QTY	PART NO	DESCRIPTION
7	1	48515	Drive Pin w/ Bail	12	2	47189	Nylock Nut, 1/4"
8	2	43093	Cotter Pin, 1/8" x 1-1/2"	13	2	47810	Nylock Nut, 5/16"
9	1	43343	Hair Cotter Pin, 1/8"	14	1	47623	Hitch Pin
10	2	1509-69	Hex Bolt, 1/4-20 x 1-3/4"	15	2	47683	Spacer
11	2	43084	Hex Bolt, 5/16-18 x 1/34"	16	4	43009	Washer

ASSEMBLY

TOOLS REQUIRED FOR ASSEMBLY

- (1) Pliers
- (2) 7/16" Wrenches
- (2) 1/2" Wrenches
- (2) 9/16" Wrenches

REMOVAL OF PARTS FROM CARTON

Remove all parts and hardware packages from the carton. Lay out all parts and hardware and identify using the illustrations on pages 3.

STEP 1: (SEE FIGURE 1)

- Turn the spreader upside down.
- Remove the lock nut from the middle bolt in the crossover tube and shaft support plate. Leave the bolt in place.
- Assemble the hitch tube onto the middle bolt and secure it with the same lock nut you removed. **DO NOT TIGHTEN YET.**

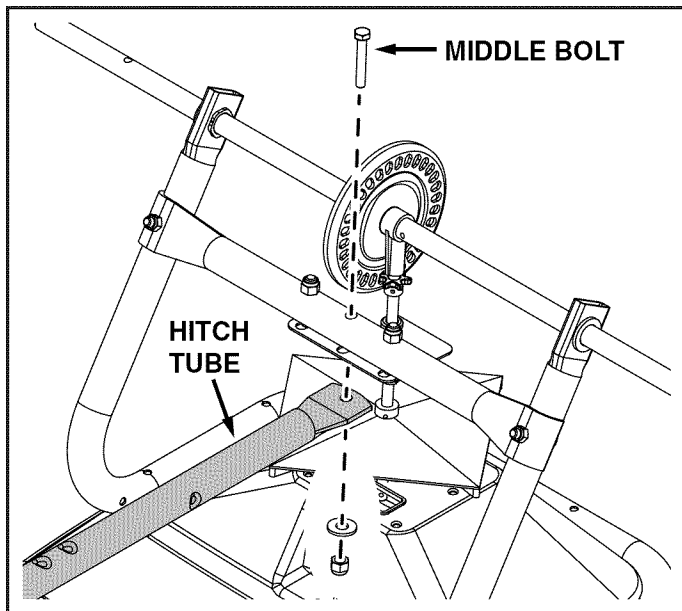

FIGURE 1

STEP 2: (SEE FIGURE 2)

- Assemble the **OUTER** hitch braces to the hitch tube using a 1/4" x 1-3/4" hex bolt and a 1/4" nylock hex nut. **DO NOT TIGHTEN YET.** Do not assemble the inner hitch braces at this time.

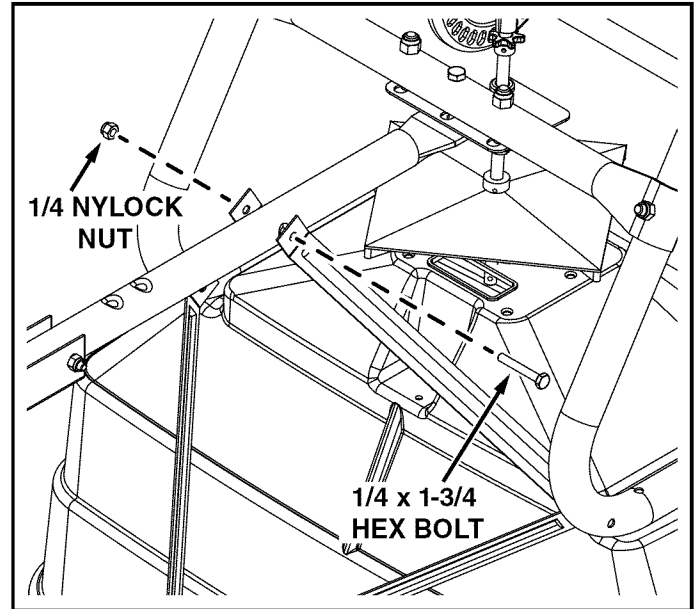

FIGURE 2

STEP 3: (SEE FIGURE 3)

- Assemble a spacer, a washer, a wheel (air valve facing out) and another washer onto the end of the axle that has only the **small hole**.
- Install a 1/8" x 1-1/2" cotter pin into hole in the axle.

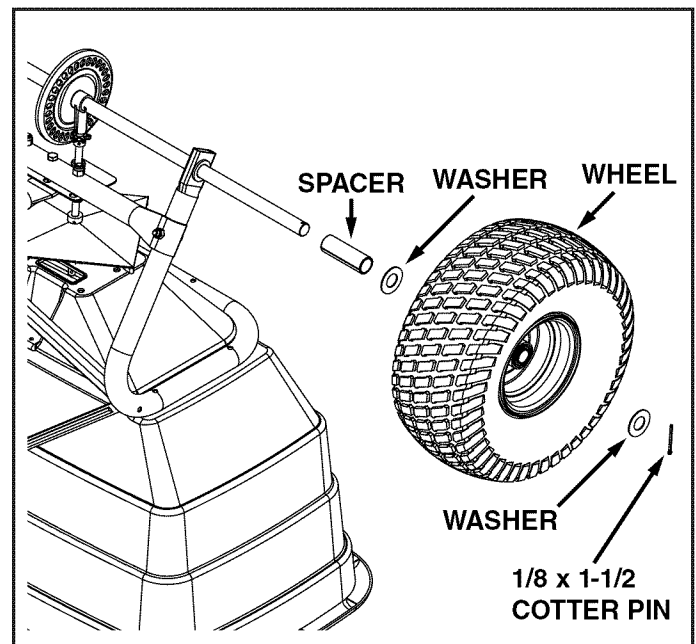

FIGURE 3

STEP 4: (SEE FIGURE 4)

- Assemble a spacer, a washer, a wheel (air valve facing out) and another washer onto the end of the axle that has both the **large and small holes**.
- Install a 1/8" x 1-1/2" cotter pin into the small hole in the end of the axle.
- Open the bail on the drive pin and install it through the wheel and the large hole in the axle. Close the bail to lock the pin in place.

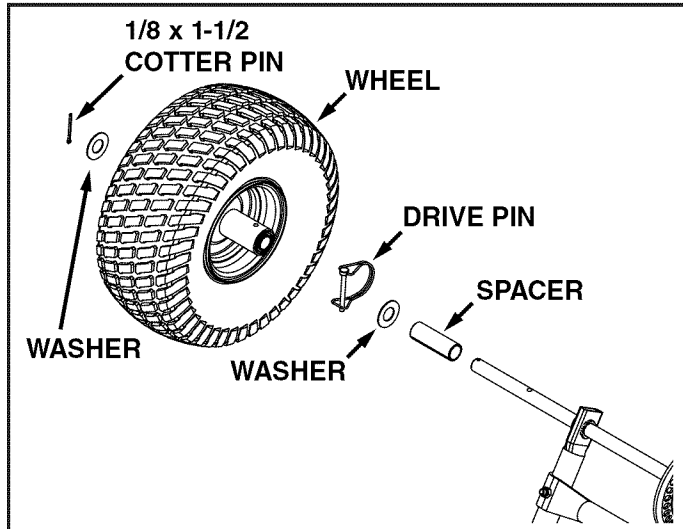

FIGURE 4

STEP 6: (SEE FIGURE 6)

- Turn the spreader upright on its wheels.
- Hook the double bent end of the flow control rod through the hole in the slide gate bracket located near the bottom of the hopper.

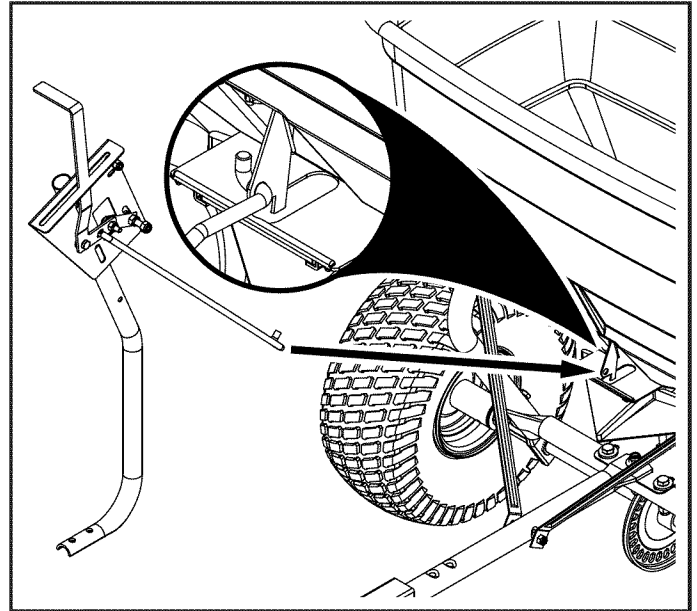

FIGURE 6

STEP 5: (SEE FIGURE 5)

- Insert the end of the flow control rod with only one bend into the hole in the lever on the flow control tube assembly.

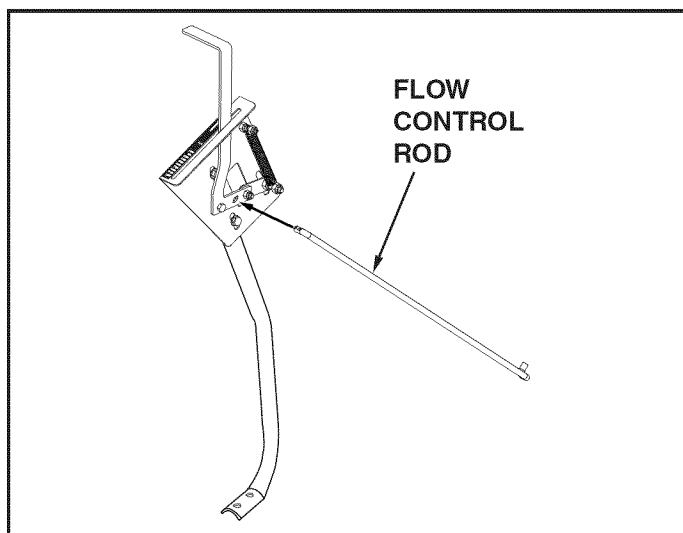

FIGURE 5

STEP 7: (SEE FIGURE 7)

- Assemble the flow control mounting tube to the hitch tube using two 5/16" x 1-3/4" hex bolts and 5/16" nylock hex nuts. **DO NOT TIGHTEN YET.**

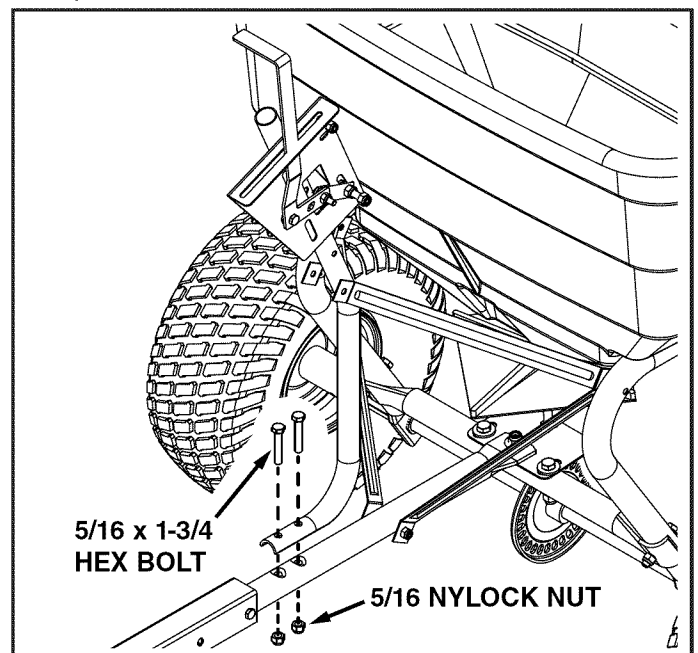

FIGURE 7

STEP 8: (SEE FIGURE 8)

- Assemble the two **INNER** hitch braces to the flow control mounting tube using a 1/4" x 1-3/4" hex bolt and a 1/4" nylock hex nut. **TIGHTEN**.
- **TIGHTEN** all nuts and bolts assembled up to this point. **Do not collapse tubes when tightening.**

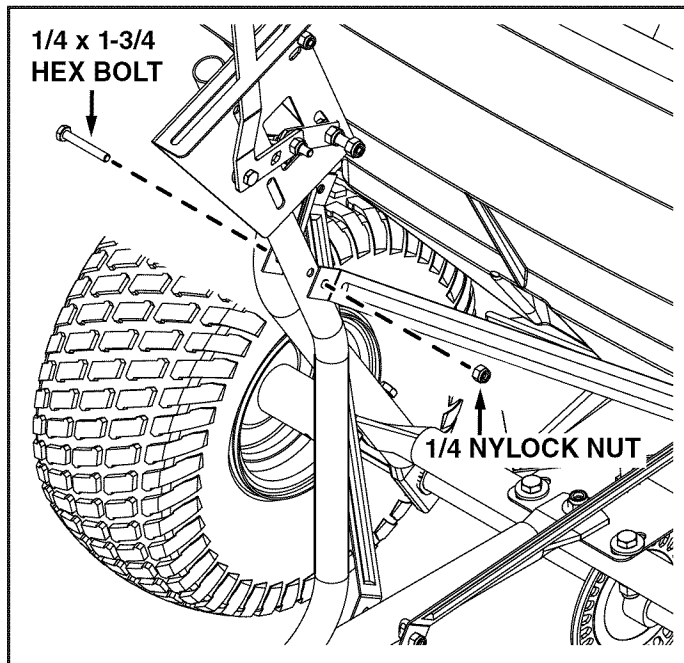

FIGURE 8

STEP 9: (SEE FIGURE 9)

- For most vehicles, the hitch tube assembly should be left in the default position.
- Attach the spreader hitch to your vehicle hitch.
- Check for interference with the spreader directly behind and out to both sides of the vehicle. Lift the spreader at each position to make sure there is no interference with the spreader's flow control.
- If there is interference with the rear of the vehicle, extend the hitch tube assembly.

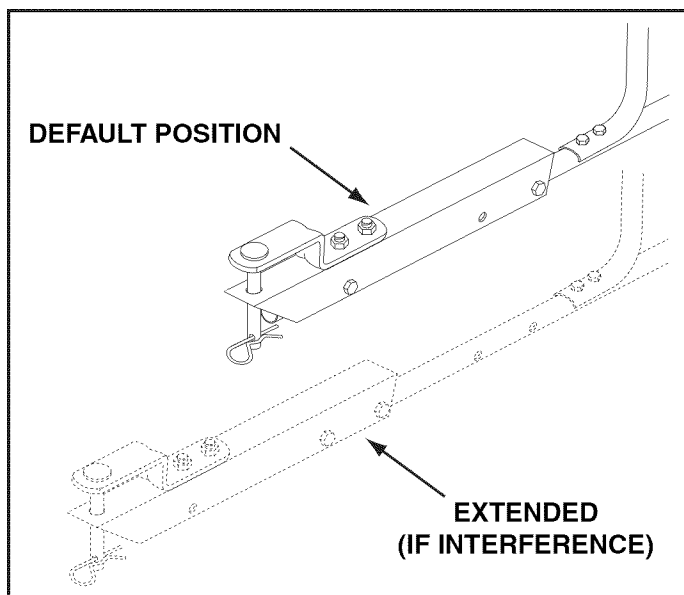

FIGURE 9

STEP 10: (SEE FIGURE 10)

- Calibrate the flow setting. Follow the steps in order below.
 1. Push flow control arm to "OFF" position.
 2. Slide flow control mounting bracket along tube until closure plate in bottom of hopper just closes.
 3. Snug the 5/16" nylock hex nuts just enough to hold flow control mounting bracket in place.
 4. Set adjustable stop at "5". Pull flow control arm against stop. Verify that closure plate has opened about half way.
 5. If closure plate does not open half way, adjust position of flow control mounting bracket until closure plate will open about half way at "5" and will still close when arm is locked in "OFF" position. **Tighten** the 5/16" nylock hex nuts.

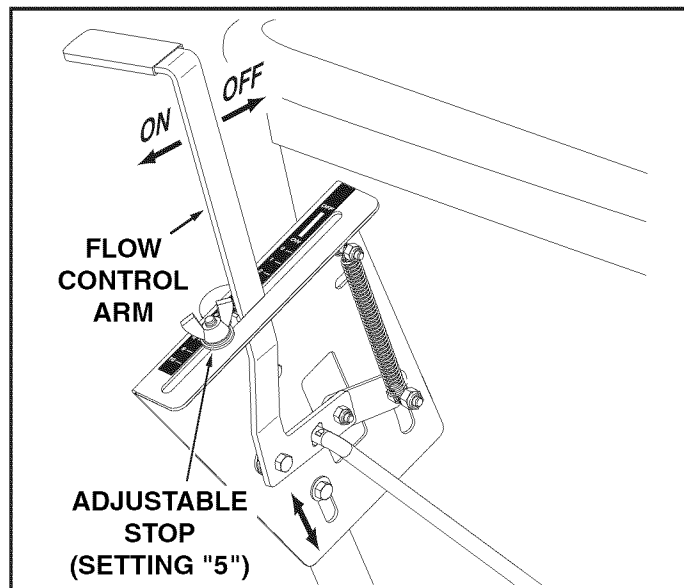

FIGURE 10

OPERATION

KNOW YOUR SPREADER

Read this owner's manual and safety rules before operating your spreader.

Compare the illustration below with your spreader to familiarize yourself with the various controls and their locations.

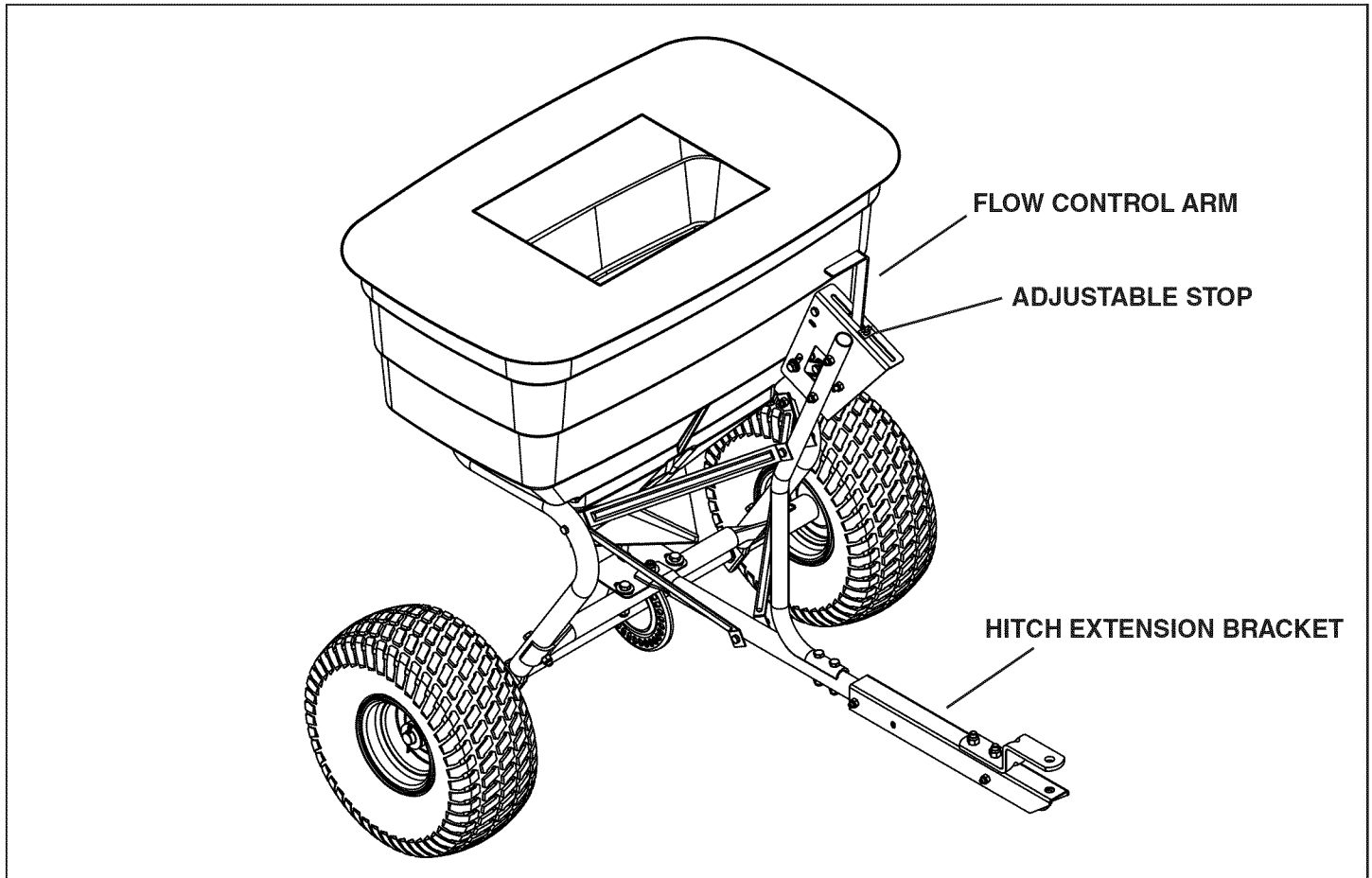

FLOW CONTROL ARM - Opens and closes the closure plate in the bottom of the hopper.

ADJUSTABLE STOP - Limits how far the closure plate opens.

CLOSURE PLATE (not shown) - Slides to open or close the opening in the bottom of the hopper.

HITCH EXTENSION BRACKET - Adjusts to allow more clearance between the spreader and towing vehicle

HOW TO USE YOUR SPREADER

SETTING THE FLOW CONTROL

- Loosen the nylon wing nut, set the adjustable stop to the desired flow rate setting and retighten the wing nut. The higher the setting number, the wider the opening in the bottom of the hopper.
- Refer to the application chart on this page and to the instructions on the fertilizer bag to select the proper flow rate setting.
- Pull the flow control arm against the adjustable stop for the on position and toward the hopper for the off position.

FREE WHEELING FEATURE

- The spreader is equipped with a removable pin in the left (drive) wheel.
- Remove the pin to disengage the drive wheel so that the axle, gears, and spreader plate do not rotate.
- With the drive wheel disengaged, the spreader may be towed at speeds up to 20 mph.
- If the drive wheel is engaged, do not exceed 6 mph.

OPERATING TIPS

We do not recommend the use of any powdered lawn chemicals due to the difficulty in obtaining a satisfactory or consistent broadcast pattern.

- Determine approximate square footage of area to be covered and estimate amount of material required.
- Before filling the hopper, make sure the flow control arm is in the off position and the closure plate is shut.
- Break up any lumpy fertilizer as you fill the hopper.
- Set the adjustable stop with the flow control arm still in the off position. Refer to the application chart on this page and to the instructions on the fertilizer bag to select the proper flow rate setting.
- The application chart is calculated for light to heavy application at a vehicle speed of 3 mph, or 100 ft. in 23 seconds. A variation in speed will require an adjustment of the flow rate to maintain the same coverage. The faster you drive, the wider the broadcast width.
- Make sure the drive pin is installed in the axle before starting the spreader.
- Always start the tractor in motion before opening closure plate.
- Always shut the closure plate before turning or stopping the tractor.
- If fertilizer is accidentally deposited too heavily in a small area, soak the area thoroughly with a garden hose or sprinkler to prevent burning of the lawn.
- To insure uniform coverage, make each pass so that the broadcast pattern slightly overlaps the pattern from the previous pass as shown in figure 13. The approximate broadcast widths for different materials are shown in the application chart on this page.

- When broadcasting weed control fertilizers, make sure the broadcast pattern does not hit evergreen trees, flowers, or shrubs.
- Heavy moisture conditions may require a cover over the hopper to keep contents dry. The vinyl cover acts as a wind and moisture shield, but should not be used as a rain cover.

IMPORTANT: Application rates shown in the chart are affected by humidity and by the moisture content of the material (granular and pellet). Some minor setting adjustments may be necessary to compensate for this condition.

APPLICATION CHART		
TYPE OF MATERIAL	FLOW SETTING	SPREAD WIDTH
FERTILIZER		
Powder	3 - 5	3' - 4'
Granular	3 - 5	8' - 10'
Pelleted	3 - 5	10' - 12'
Organic	6 - 8	6' - 8'
GRASS SEED		
Fine	3 - 4	6' - 7'
Coarse	4 - 5	8' - 9'
ICE MELTER	6 - 8	10' - 12'

OPERATING SPEED - 3 MPH (100 ft. in 23 seconds)

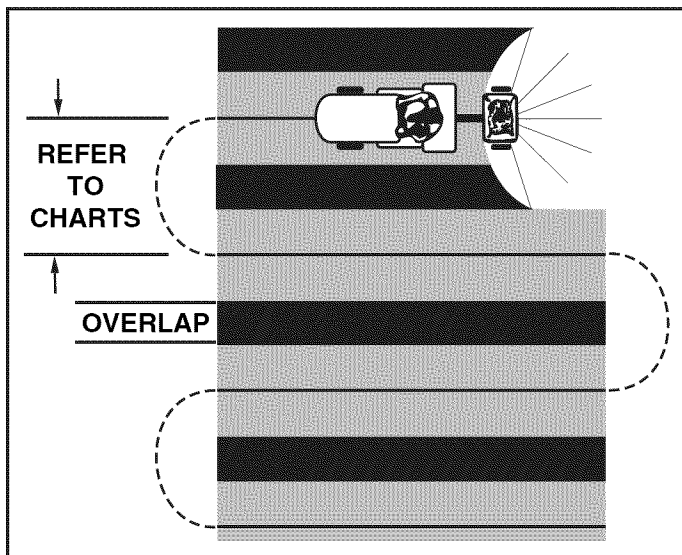

FIGURE 13

MAINTENANCE

CHECK FOR LOOSE FASTENERS

- Before each use make a thorough visual check of the spreader for any bolts and nuts which may have loosened. Retighten any loose bolts and nuts.

CHECK FOR WORN OR DAMAGED PARTS

- Check for worn or damaged parts before each use. Repair or replace parts if necessary.

CHECK TIRE INFLATION

- Check if tires are adequately inflated before each use.



CAUTION: DO NOT inflate tires beyond the maximum recommend pressure printed on side of tire.

LUBRICATE (See figure 11)

- Lightly apply automotive grease as needed to the sprocket and gear.
- Oil the nylon bushings on the vertical sprocket shaft and on the axle at least once a year, or more often as needed.
- Oil right hand (idler) wheel bearing at least once a year or more often as needed.

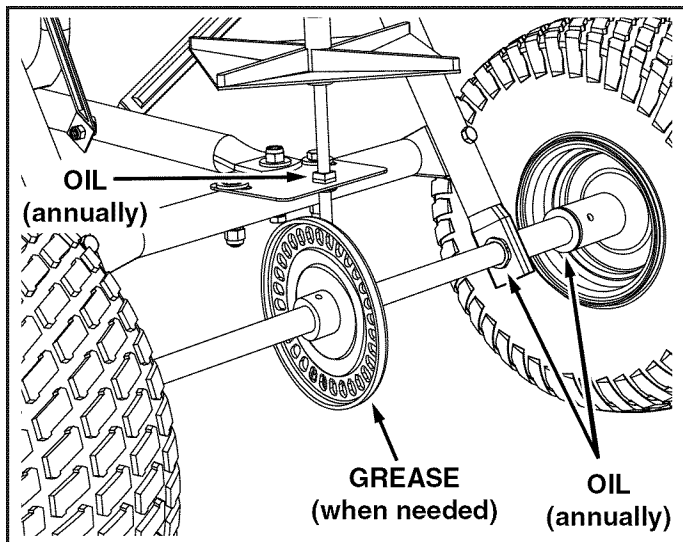

FIGURE 11

STORAGE

- Rinse inside of hopper and exterior of spreader and dry off before storing.
- Store in a clean, dry area.

TROUBLESHOOTING

LOCKED UP SPREADER

- Turn the spreader over so that the wheels are off the ground.
- Loosen all three nuts on the shaft support plate so that the bolts can be turned easily with a wrench but cannot be turned by hand.
- Spin the drive wheel and note how freely it spins and how much noise the gear makes.
- To free up wheel and gear, tap gently on the front or rear edge of the shaft support plate to move it slightly forward or backward. You can also tap at the corners of the plate to angle it slightly.
- Spin the drive wheel after each adjustment to see if it spins more freely and if the gear noise is reduced.
- Continue making slight adjustments until you find the position where the drive wheel spins most freely and the gear makes the least noise.
- Secure the shaft support plate in this position by retightening all three nuts that you loosened.

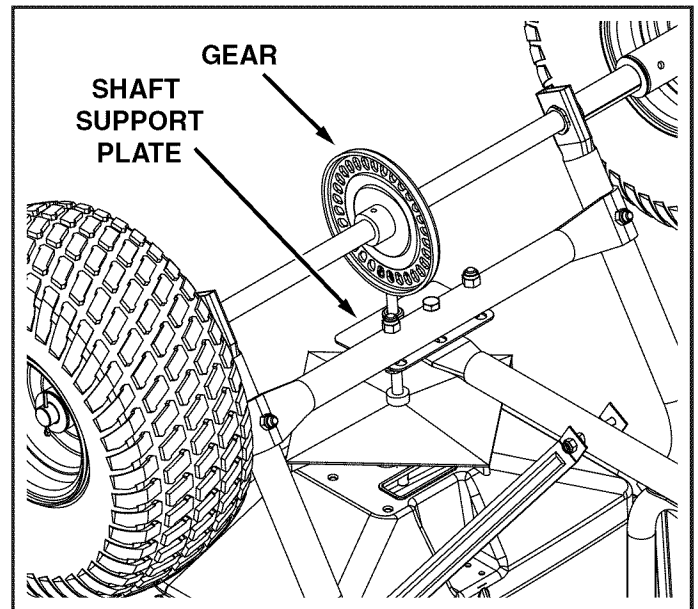
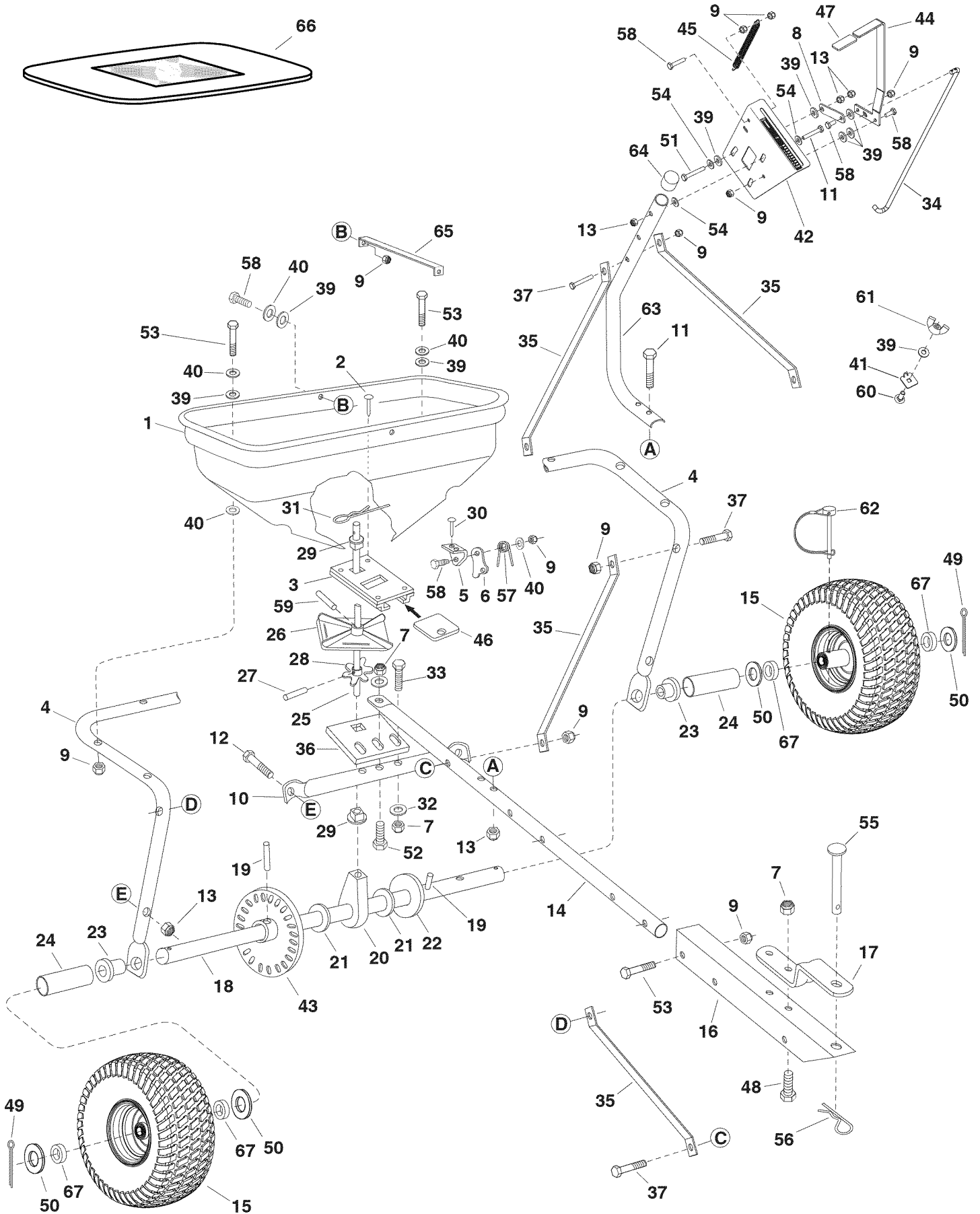

FIGURE 12

REPAIR PARTS ILLUSTRATION



REPAIR PARTS LIST

REF	QTY	PART NO	DESCRIPTION	REF	QTY	PART NO	DESCRIPTION
1	1	44480	Hopper	35	4	23525	Hitch Brace
2	4	41157	Rivet, Stainless	36	1	23762	Shaft Support Plate
3	1	65129	Guide Closure Assembly	37	4	1509-69	Hex Bolt, 1/4-20 x 1-3/4"
4	1	44462	Frame Tube	38	1	42505	Plastic Grate
5	1	23753	Slide Gate Angle Bracket	39	14	1543-69	Nylon Washer
6	1	23758	Slide Gate Bracket	40	15	43088	Flat Washer, 1/4"
7	5	HA21362	Nylock Hex Nut, 3/8-16	41	1	27177	Adjustable Stop
8	1	24857	Flow Control Link	42	1	24915	Flow Control Mount Bracket
9	19	47189	Nylock Hex Nut, 1/4-20	43	1	62474	Gear Assembly
10	1	43808	Crossover Tube	44	1	24917	Flow Control Arm
11	4	43084	Hex Bolt, 5/16-18 x 1-3/4"	45	1	43000	Spring
12	2	44180	Hex Bolt, 5/16-18 x 2"	46	1	23533	Closure Plate
13	8	47810	Nylock Hex Nut, 5/16-18	47	1	43848	Flow Control Arm Grip
14	1	48864	Hitch Tube	48	2	43001	Hex Bolt, 3/8-16 x 1"
15	2	48511G	Wheel	49	2	43093	Cotter Pin, 1/8" x 1-1/2"
16	1	25080	Hitch Extension Bracket	50	4	43009	Flat Washer, 3/4"
17	1	23014	Hitch Bracket	51	1	43085	Hex Bolt, 5/16-18 x 1-1/2"
18	1	24914	Axle Shaft	52	1	HA180132	Hex Bolt, 3/8-16 x 2-1/4"
19	2	43851	Spring Pin, 3/16 x 3-1/4"	53	8	46699	Hex Bolt, 1/4-20 x 2"
20	1	43871	Axle Shaft Bushing	54	5	43081	Washer, 5/16"
21	5	44008	Flat Washer, .78"	55	1	47623	Hitch Pin
22	1	1540-162	Flat Washer, 1/2"	56	1	43343	Hair Cotter Pin, 1/8"
23	2	47615	Flange Bearing	57	1	44566	Torsion Spring
24	2	47683	Spacer Tube	58	6	43661	Hex Bolt, 1/4-20 x 1"
25	1	25305	Sprocket Shaft	59	1	46055	Spring Pin, 1/8 x 1"
26	1	04367	Spreader Plate	60	1	44950	Carriage Bolt, 1/4-20 x 3/4"
27	1	43850	Spring Pin, 1/8 x 5/8"	61	1	47141	Nylon Wing Nut
28	1	44468	6 Tooth Sprocket	62	1	48515	Drive Pin w/Bail, 1/4 x 2"
29	2	44285	Delrin Bushing	63	1	48514	Flow Control Mounting Tube
30	2	C-9M5732	Rivet	64	1	44481	Vinyl Cap
31	1	48934	Hairpin Agitator	65	1	23697	Hopper Strap
32	3	43070	Flat Washer, 3/8"	66	1	40825	Vinyl Cover
33	2	43054	Hex Bolt, 3/8-16 x 2"	67	4	43631	Ball Bearing
34	1	41549	Flow Control Rod		1	42523	Owners Manual

To order replacement parts, call Sears Parts Direct 1-800-252-1698
or go to www.searspartsdirect.com