

OWNER'S MANUAL

F60 Treadmill

Please carefully read this entire manual
before operating your new treadmill.

SOLE

FITNESS

TABLE OF CONTENTS

Product Registration	1
Important Safety Instructions	2
Important Electrical Information	3
Important Operation Instructions	4
Assembly instructions	8
Folding Instructions	11
Transport Instructions	11
Operation of Your New Treadmill	12
Programmable Features	16
Using Heart Rate Transmitter	21
General Maintenance	23
Service Checklist - Diagnosis Guide	26
Manufacturer's Limited Warranty	28

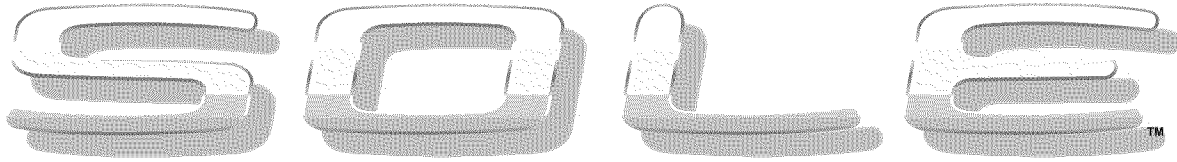

FITNESS

CONGRATULATIONS ON YOUR NEW TREADMILL AND WELCOME TO THE SOLE FAMILY!

Thank you for your purchase of this quality treadmill from **SOLE**. Your new treadmill has been manufactured by one of the leading fitness manufacturers in the world and is backed by one of the most comprehensive warranties available. **SOLE** will do all we can to make your ownership experience as pleasant as possible for many years to come.

If you have any questions about your new product or questions about the warranty contact **SOLE** Fitness at **1-866-780-SOLE (7653)**. If you have a technical problem with your new treadmill contact **SOLE** technical service at **866-MYSOLE1 (1-866-697-6531)**.

If you purchased this fitness product from Sears, they will be your contact for all service needs. Please see the last page in this manual for detailed information about Sears service. To contact Sears for any service issues call 1-800-4-MY-HOME(1-800-469-4663).

Please take a moment at this time to record below the name of the dealer, their telephone number, and the date of purchase for easy contact in the future. We appreciate your confidence in **SOLE** and we will always remember that you are the reason that we are in business. Please complete and mail your registration card today and enjoy your new treadmill.

Yours in Health,
SOLE Fitness

Name of Dealer _____

Telephone Number of Dealer _____

Purchase Date _____

PRODUCT REGISTRATION

RECORD YOUR SERIAL NUMBER

Please record the Serial Number of this fitness product in the space provided below.

Serial Number _____

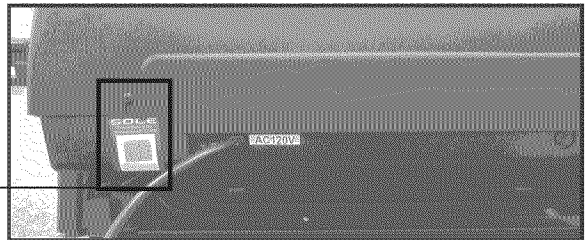

REGISTER YOUR PURCHASE

The self-addressed product registration card must be completed in full and returned to **SOLE**. You can also go to **www.soletreadmills.com** under the support tab to register online.

F60_20121224

IMPORTANT SAFETY INSTRUCTIONS

WARNING - Read all instructions before using this appliance.

DANGER - To reduce the risk of electric shock disconnect your SOLE treadmill from the electrical outlet prior to cleaning and/or service work.

WARNING - To reduce the risk of burns, fire, electric shock, or injury to persons, install the treadmill on a flat level surface with access to a 110-volt, 15-amp grounded outlet with only the treadmill plugged into the circuit.

DO NOT USE AN EXTENSION CORD UNLESS IT IS A 14AWG OR BETTER, WITH ONLY ONE OUTLET ON THE END: DO NOT ATTEMPT TO DISABLE THE GROUNDED PLUG BY USING IMPROPER ADAPTERS, OR IN ANY WAY MODIFY THE CORD SET.

A serious shock or fire hazard may result along with computer malfunctions. See Grounding Instructions, page 3.

- Do not operate treadmill on deeply padded, plush or shag carpet. Damage to both carpet and treadmill may result.
- Do not block the rear of the treadmill. Provide a minimum of 3 1/2 feet clearance between the rear of the treadmill and any fixed object.
- Keep children away from the treadmill. There are obvious pinch points and other caution areas that can cause harm.
- Keep hands away from all moving parts.
- Never operate the treadmill if it has a damaged cord or plug. If the treadmill is not working properly, call your dealer.
- Keep the cord away from heated surfaces.
- Do not operate where aerosol spray products are being used or where oxygen is being administered. Sparks from the motor may ignite a highly gaseous environment.
- Never drop or insert any object into any openings.
- Do not use outdoors.
- To disconnect, turn all controls to the off position, remove tether cord, then remove the plug from the outlet.
- Do not attempt to use your treadmill for any purpose other than for the purpose it is intended.
- The pulse sensors are not medical devices. Various factors, including the user's movement, may affect the accuracy of heart rate readings. The pulse sensors are intended only as exercise aids in determining heart rate trends in general.
- Use handrails provided; they are for your safety.
- Wear proper shoes. High heels, dress shoes, sandals or bare feet are not suitable for use on your treadmill. Quality athletic shoes are recommended to avoid leg fatigue.

Remove tether cord after use to prevent unauthorized treadmill operation.

SAVE THESE INSTRUCTIONS - THINK SAFETY!

IMPORTANT ELECTRICAL INSTRUCTIONS

WARNING!

NEVER use a ground fault circuit interrupt (GFCI) wall outlet with this treadmill. As with any appliance with a large motor, the GFCI will trip often. Route the power cord away from any moving part of the treadmill including the elevation mechanism and transport wheels.

NEVER remove any cover without first disconnecting AC power.

If voltage varies by ten percent (10%) or more, the performance of your treadmill may be affected. Such conditions are not covered under your warranty. If you suspect the voltage is low, contact your local power company or a licensed electrician for proper testing.

NEVER expose this treadmill to rain or moisture. This product is NOT designed for use outdoors, near a pool or spa, or in any other high humidity environment. The maximum operating temperature specification is 40 degrees C, and humidity is 95% non-condensing (no water drops forming on surfaces).

Circuit Breakers: Some circuit breakers used in homes are not rated for high inrush currents that can occur when a treadmill is first turned on or even during use. If your treadmill is tripping the house circuit breaker (even though it is the proper current rating) but the fuse on the treadmill itself does not trip, you will need to replace the home breaker with a high inrush type. This is not a warranty defect. This is a condition we as a manufacture have no ability to control. This part is available through most electrical supply stores. Examples:

Grainger part # 1D237, or available online at www.squared.com part # QO120HM.

GROUNDING INSTRUCTIONS

This product must be grounded. If the treadmill should malfunction or breakdown, grounding provides a path of least resistance for electric current, reducing the risk of electric shock. This product is equipped with a cord having an equipment-grounding plug. The plug must be plugged into an appropriate outlet that is properly installed and grounded in accordance with all local codes and ordinances.

DANGER - Improper connection of the equipment-grounding conductor can result in a risk of electric shock. Check with a qualified electrician or serviceman if you are in doubt as to whether the product is properly grounded. Do not modify the plug provided with the product if it will not fit the outlet; have a proper outlet installed by a qualified electrician.

This product is for use on a nominal 110-volt circuit, and has a grounding plug that looks like the plug illustrated below. A temporary adapter that looks like the adapter illustrated below may be used to connect this plug to a 2-pole receptacle as shown below if a properly grounded outlet is not available. The temporary adapter should be used only until a properly grounded outlet, (shown below) can be installed by a qualified electrician. The green colored rigid ear-lug, or the like, extending from the adapter, must be

connected to a permanent ground such as a properly grounded outlet box cover. Whenever the adapter is used, it must be held in place by a metal screw.

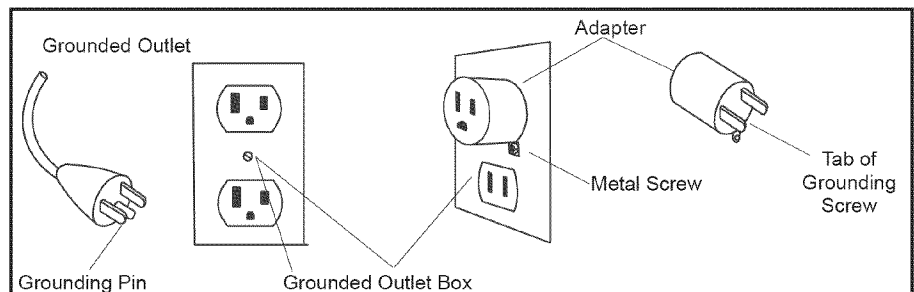

IMPORTANT OPERATION INSTRUCTIONS

- **NEVER** operate this treadmill without reading and completely understanding the results of any operational change you request from the computer.
- Understand that changes in speed and incline do not occur immediately. Set your desired speed on the computer console and release the adjustment key. The computer will obey the command gradually.
- **NEVER** use your treadmill during an electrical storm. Surges may occur in your household power supply that could damage treadmill components. Unplug the treadmill during an electrical storm as a precaution.
- Use caution while participating in other activities while walking on your treadmill; such as watching television, reading, etc. These distractions may cause you to lose balance or stray from walking in the center of the belt; which may result in serious injury.
- **NEVER** mount or dismount the treadmill while the belt is moving. **SOLE** treadmills start at a very low speed and it is unnecessary to straddle the belt during start up. Simply standing on the belt during slow acceleration is proper after you have learned to operate the unit.
- Always hold on to a handrail or hand bar while making control changes (incline, speed, etc.).
- Do not use excessive pressure on console control keys. They are precision set to function properly with little finger pressure. Pushing harder is not going to make the unit go faster or slower. If you feel the buttons are not functioning properly with normal pressure contact your **SOLE** dealer.

IMPORTANT SAFETY INSTRUCTIONS

A safety tether cord is provided with this unit and should be used at all times. It is for your safety should you fall or move too far back on the tread-belt. Pulling this safety tether cord will stop tread-belt movement.

To Use:

1. Place the safety key into position on the console control head. Your treadmill will not start and operate without this. Removing the safety key also secures the treadmill from unauthorized use.
2. Fasten the plastic clip onto your clothing securely to assure good holding power.
Note: *The clip should be attached securely to make certain it does not come off. Be familiar with its function and limitations. The treadmill will stop, depending on speed, with a one to two step coast anytime the safety key is pulled off the console. Use the red **Stop** switch in normal operation.*

IMPORTANT SAFETY INSTRUCTIONS

READ BEFORE UNPACKING YOUR FOLDING TREADMILL

Serious injury could occur if this folding treadmill is not unpacked properly.

There is a Velcro strap installed around the treadmill base that prevents the treadmill from unfolding accidentally during shipping. If this strap is not removed properly the treadmill could spring open unexpectedly and cause injury if someone is standing near the treadmill when the strap is removed.

To ensure your personal safety during removal of the shipping strap please make sure the treadmill is positioned flat on the ground, in the orientation it would be in if you were using the treadmill. Do not turn the treadmill up on its side while removing the shipping strap. This could cause the treadmill's folding mechanism to spring open. If the end of the Velcro strap (that you need to grab to remove it) happens to be under the treadmill deck, reach under the deck to grab it, but do not tilt the treadmill up to gain access to the strap end.

PREVENTATIVE MAINTENANCE CHART

Vacuum Under Motor Cover & Check Wiring (Every Other Month)	Clean & Inspect Deck for Lubrication (Every Other Month)	Lubricate Deck (Every 90 hours or sooner if dry)	Inspect Belt Tracking (Monthly) Adjust if necessary	Date

F60 ASSEMBLY PACK CHECKLIST

2 HARDWARE STEP 2

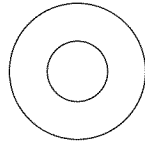

#76. $\text{Ø}5/16'' \times \text{Ø}18\text{mm} \times 1.5\text{T}$
Flat Washer (8 pcs)

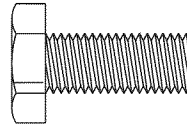

#97. $5/16'' \times 1/2''$
Hex Head Bolt (8 pcs)

3 HARDWARE STEP 3

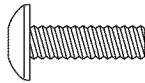

#95. M5 x 15mm
Button Head Socket Bolt (6 pcs)

5 HARDWARE STEP 5



#93. $\text{Ø}10$
Split Washer (4 pcs)

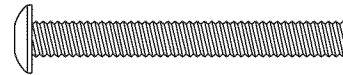

#94. $3/8'' \times 1-1/2''$
Button Head Socket Bolt (4 pcs)

6 HARDWARE STEP 6

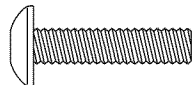

#96. $5/16'' \times 3/4''$
Button Head Socket Bolt (4 pcs)

ASSEMBLY TOOLS

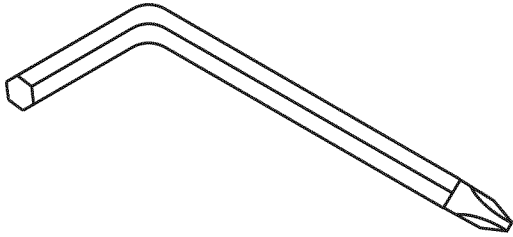

#98. Combination M5 Allen Wrench
& Phillips Head Screw Driver

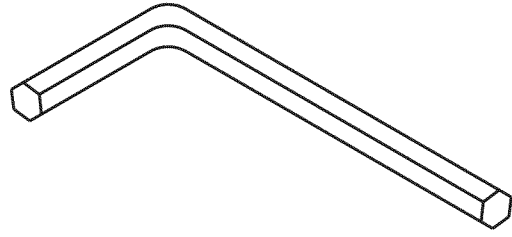

#99. M6 L Allen Wrench

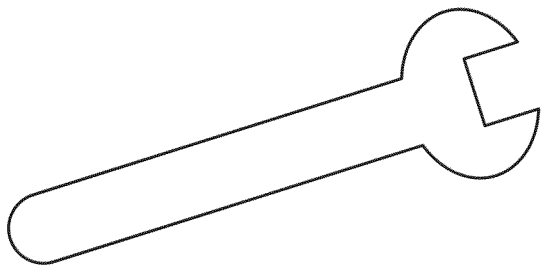

#100. 13mm Wrench

F60 ASSEMBLY INSTRUCTIONS

1 ASSEMBLY STEP 1

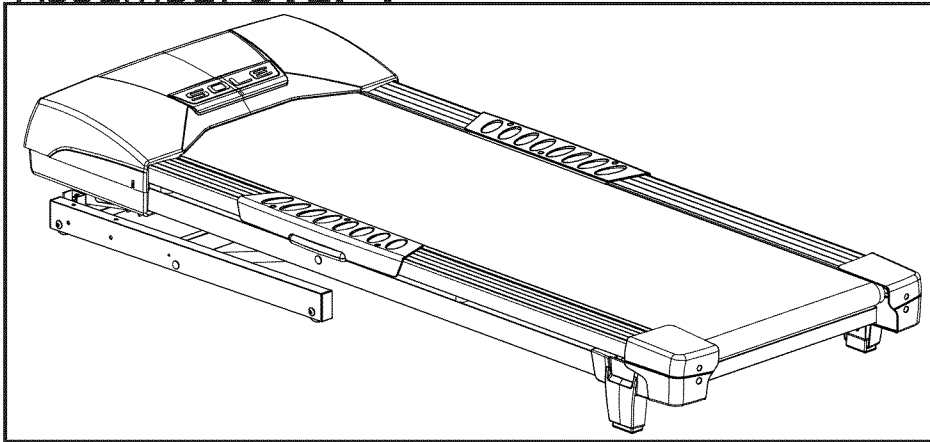

1. Remove the treadmill from the carton and position it aside on a smooth, level floor. The rear should be at least 3' from any wall. Do not remove the Velcro belt until you have removed the plastic wrap and Styrofoam from beneath the unit. **Turning the unit on its side after removing the belt may cause the unit fold up and cause serious injury!**

2 ASSEMBLY STEP 2

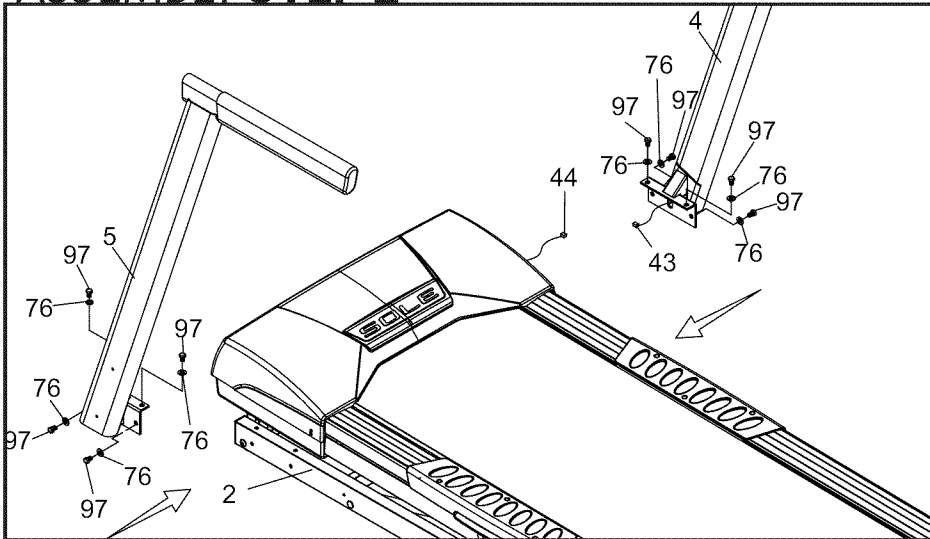

HARDWARE STEP 2

- #76. Ø5/16" x Ø18mm x 1.5T Flat Washer (8 pcs)
- #97. 5/16" x 1/2" Hex Head Bolt (8 pcs)

1. Connect Computer Cable (Upper/Lower) (44) with Computer Cable (Middle) (43) then insert Right and Left Uprights (4) and (5) into the Frame Base (2) and use the Wrench (100) to tighten eight Hex Head Bolts (97) and eight Flat Washers (76).

Before attaching the hardware to Step 3, make sure the cables you just connected don't get pinched in between the steel tubing. If they do, this may cause issues that prevent the treadmill from operating properly.

3 ASSEMBLY STEP 3

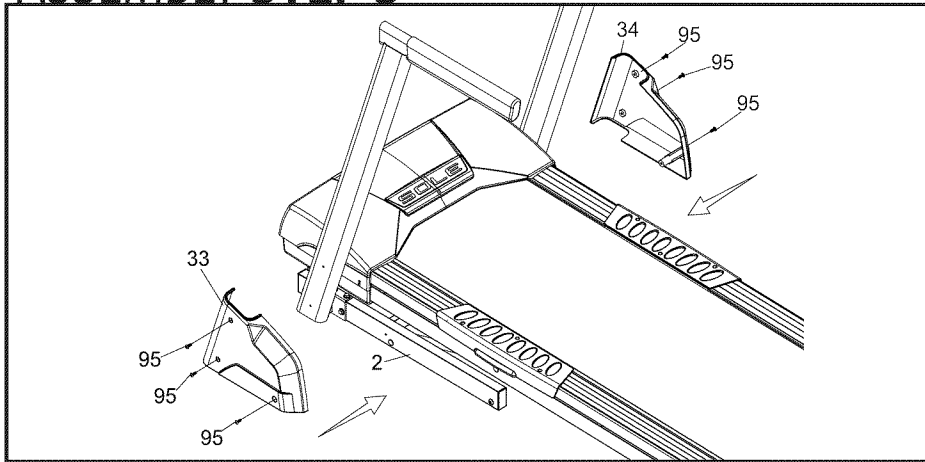

HARDWARE STEP 3

#95. M5 x 15mm
Button Head Socket Bolt
(6 pcs)

1. Install Frame Base Cover (L-33 & R-34), on the Frame Base (2) and secure with six Phillips Head Screws (95) by using Combination M5 Allen Wrench & Phillips Head Screw Driver (98).

4 ASSEMBLY STEP 4

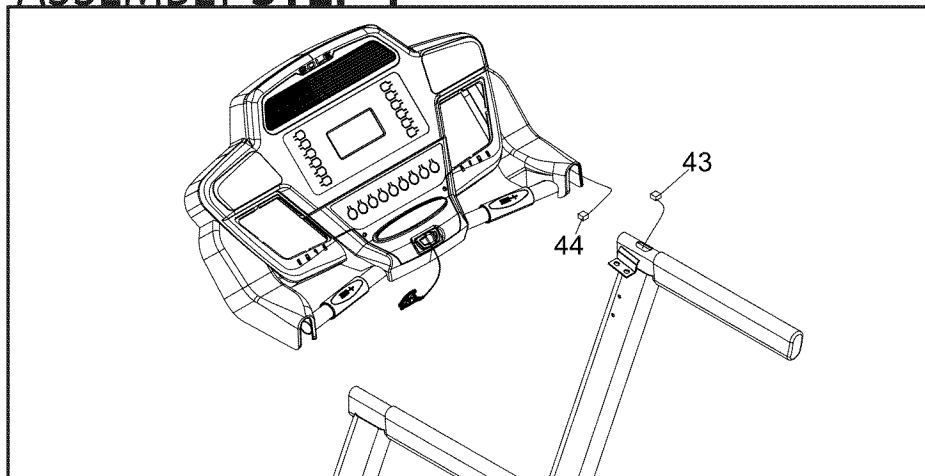

To complete this step, it is recommended that you find something to rest the console on at the appropriate height or have someone hold the console while you connect the cables.

1. Connect Computer Cable (Upper/Lower) (44) with Computer Cable (Middle) (43).

Before attaching the hardware to Step 5, make sure the cables you just connected don't get pinched in between the steel tubing. If they do, this may cause issues that prevent the treadmill from operating properly.

5 ASSEMBLY STEP 5

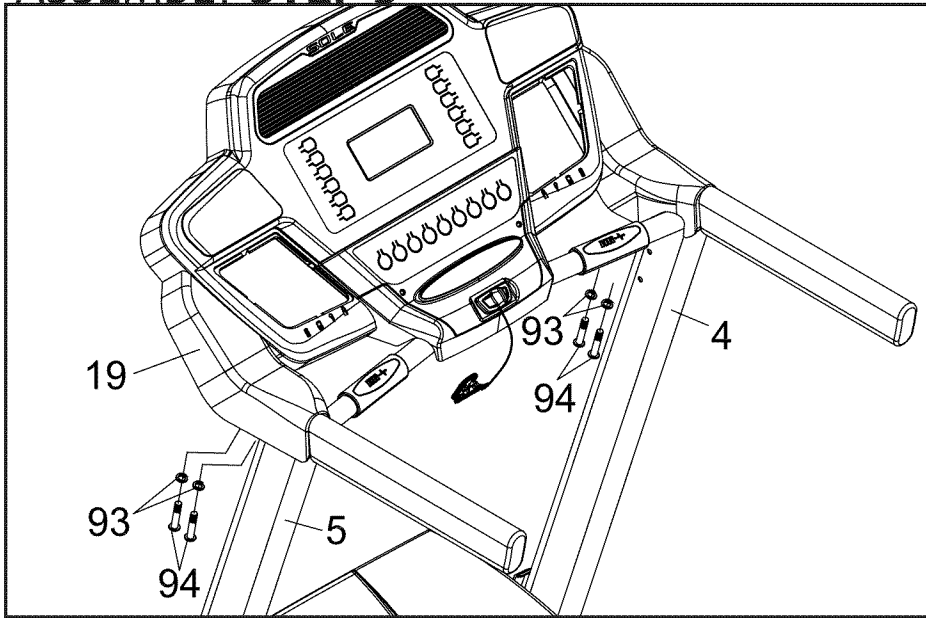

HARDWARE STEP 5

- #93. Ø10 Split Washers (4 pcs)
- #94. 3/8" x 1-1/2" Button Head Socket Bolts (4 pcs)

1. Insert Console Assembly (19) into Uprights (R-4 & L-5) and secure with four Button Head Socket Bolts (94) with four Split Washers (93) by using M6 Allen Wrench (99).

6 ASSEMBLY STEP 6

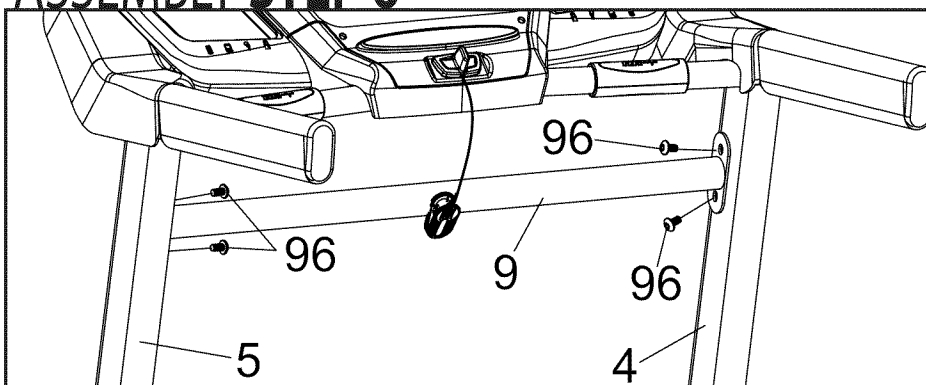

HARDWARE STEP 6

- #96. 5/16" x 3/4" Button Head Socket Bolt (4 pcs)

1. Install Handrail Support (9) between Uprights (R-4 & L-5) and use Combination M5 Allen Wrench & Phillips Head Screw Driver (98) to tighten four Button Head Socket Bolts (96).

7 ASSEMBLY STEP 7

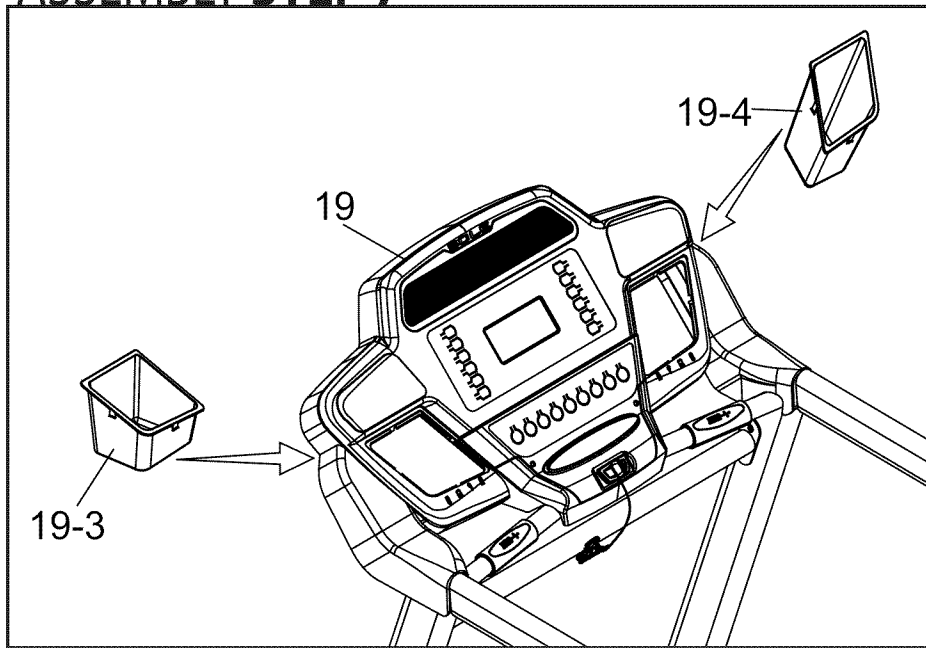

1. Put left and right Drink Bottle Holders (19-3) and (19-4) in their places on the Console Assembly (19). Press in until they snap in place.

FOLDING INSTRUCTIONS

Do not attempt to move the unit unless it is in the folded and locked position. Be sure the power cord is secured to avoid possible damage. Use both handrails to maneuver the unit to the desired position.

■ TO FOLD THE TREADMILL

Lift the deck until the latch clicks in place.

■ TO UNFOLD THE TREADMILL

Press the tube with your foot at the yellow sticker to release latch. See picture to the right.

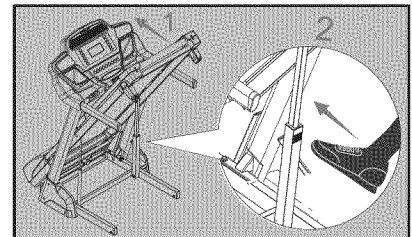

TRANSPORTATION INSTRUCTIONS

The treadmill is equipped with transport wheels that are engaged when the treadmill is folded. After folding simply roll the treadmill away.

OPERATION OF YOUR TREADMILL

GETTING FAMILIAR WITH THE CONTROL PANEL

F60 CONSOLE

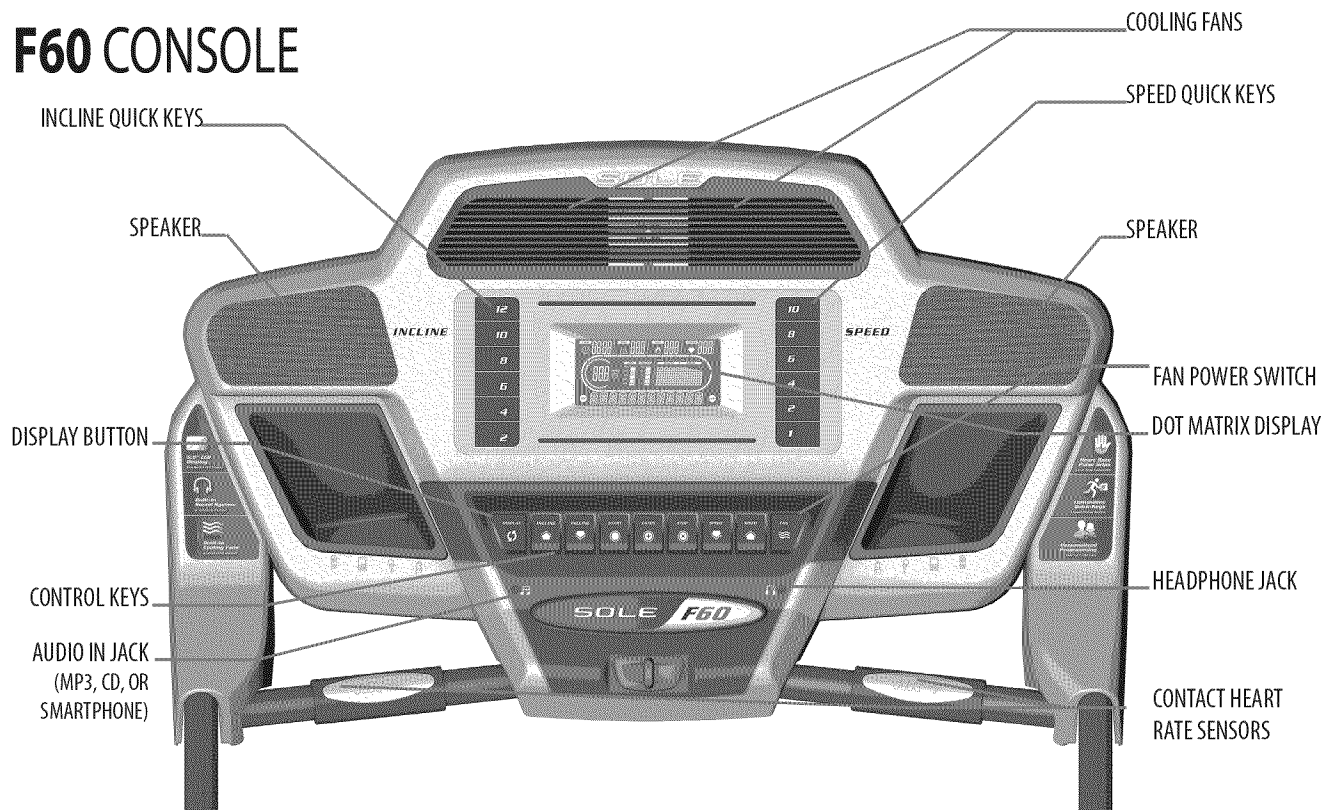

GETTING STARTED

F60 CONSOLE

Power the treadmill on by plugging it into an appropriate wall outlet, then turn on the power switch located at the front of the treadmill below the motor hood. Ensure that the **Safety Key** is installed, as the treadmill will not power on without it.

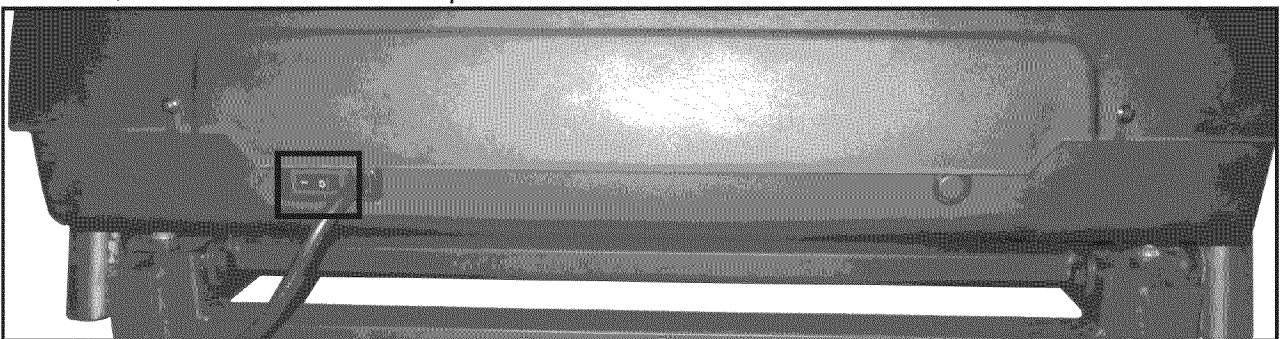

When the power is turned on, a message will scroll across the **Message Window** showing the current software version. Then the **Time** and **Distance Windows** will display Odometer readings for a short time, **Time Window** will show how many hours the treadmill has been in use and the **Distance Window** will show how many miles (or Kilometers if the treadmill is set to metric readings) the treadmill has gone. The treadmill will then enter idle mode, which is the starting point for operation.

QUICK-START OPERATION

1. Attach the **Safety Key** to wake display up (if not already on).
2. Press the **Start** key to begin belt movement then adjust to the desired speed using the **Speed** ▲ / ▼ keys on the console. You may also use the **Quick** speed keys 1, 2, 4, 6, 8, or 10 to adjust the speed.
3. To slow tread-belt press and hold the **Speed** ▼ key on the console to the desired speed. You may also press the **Quick** speed adjust keys, 1 through 10.
4. To stop the tread-belt press **Stop** key or pull away **Safety Key**.

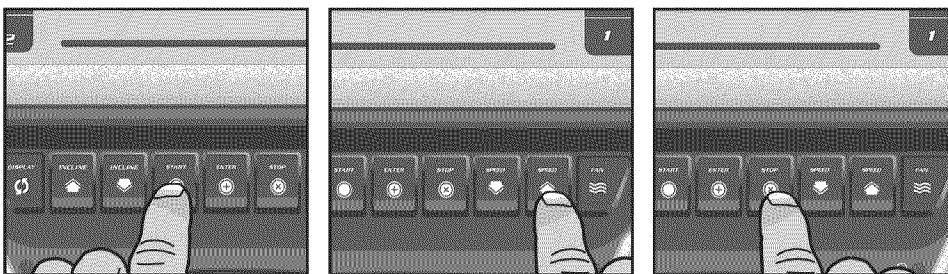

PAUSE/STOP/RESET FEATURE

1. When the treadmill is running the pause feature may be utilized by pressing the red **Stop** key once. This will slowly decelerate the tread-belt to a stop. The incline will go to zero percent. The **Time**, **Distance** and **Calorie** readings will hold while the unit is in the pause mode. After 5 minutes the display will reset and return to the start up screen.
2. To resume your exercise, when in Pause mode, press the **Start** key. The speed and incline will return to their previous settings.
 - Pause is executed when the **Stop** button is pressed once. If the **Stop** button is pressed a second time, the program will end and a workout summary will be displayed. If the **Stop** button is pressed a third time, the console will return to the idle mode (start up) screen. If the **Stop** button is held down for more than 3 seconds the console will reset.

INCLINE FEATURE

- Incline may be adjusted anytime after belt movement.
- Press and hold the **Incline** ▲ / ▼ keys on the console to achieve desired level of incline. You may also choose a more rapid increase / decrease by selecting desired key, 2, 4, 6, 8, 10, or 12 on the left hand side of console.
- The **Incline Window** display will indicate incline position as adjustments are made.

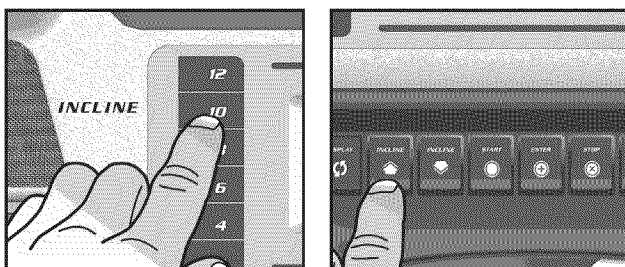

DOT MATRIX CENTER DISPLAY

Twenty columns of dots (8 high) indicate each segment of a workout. The dots are only to show an approximate level (speed/incline) of effort. They do not necessarily indicate a specific value - only an approximate percent to compare levels of intensity. In operation, the speed/incline dot matrix window will build a profile "picture" as values are changed during a workout. When the word "Speed" is lit above the dot matrix it indicates that the Speed profile is being displayed and when the word "Incline" is lit above the dot matrix it indicates the Incline profile is being displayed.

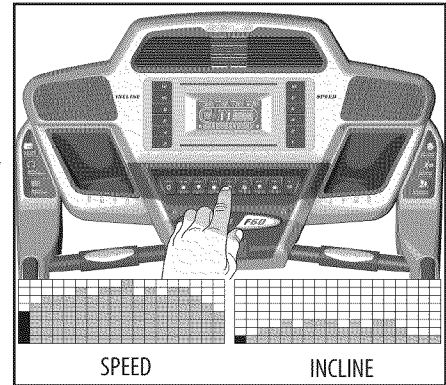

You may change the Dot Matrix profile view between Speed and Incline by pressing the **Enter** button. After pressing **Enter** to view the two profiles, pressing it a third time will automatically alternate the Speed and Incline displays, showing each one for five seconds.

1/4 MILE TRACK

The 1/4 mile track is displayed around the dot matrix window. The flashing dot indicates your progress. The number of laps you complete are accumulated in the lap counter, which is below the **Message Window**.

MESSAGE WINDOW DISPLAY

The **Message Window** will initially display **Program Name**. Each time the **Display** button is pressed the next set of information will appear. The order of information displayed will be: **Pace, Incline, Laps, Verticle, Segment Time, Max Speed** (in mph), and **Data Scan** mode. In **Data Scan** mode, the displayed information will change every 4 seconds in the **Message Window**.

CALORIE DISPLAY

Displays the cumulative calories burned at any given time during your workout.

Note: *This is only a rough guide used for comparison of different exercise sessions, which cannot be used for medical purposes.*

There is an **Audio Input Jack** (🎧) on the front of the console and built-in speakers. You may plug any low-level audio source signal into this port. Audio sources include MP3, iPod, portable radio, CD player or even a TV or computer audio signal. There is an audio patch cable included to and also a headphone jack (🎧) for private listening.

PULSE FEATURE

The **Pulse (Heart Rate) Window** will display your current heart rate in beats per minute during the workout. You must use both stainless steel sensors on the front cross bar to display your pulse or wear the wireless chest strap. The pulse value will display anytime the upper display is receiving a pulse signal.

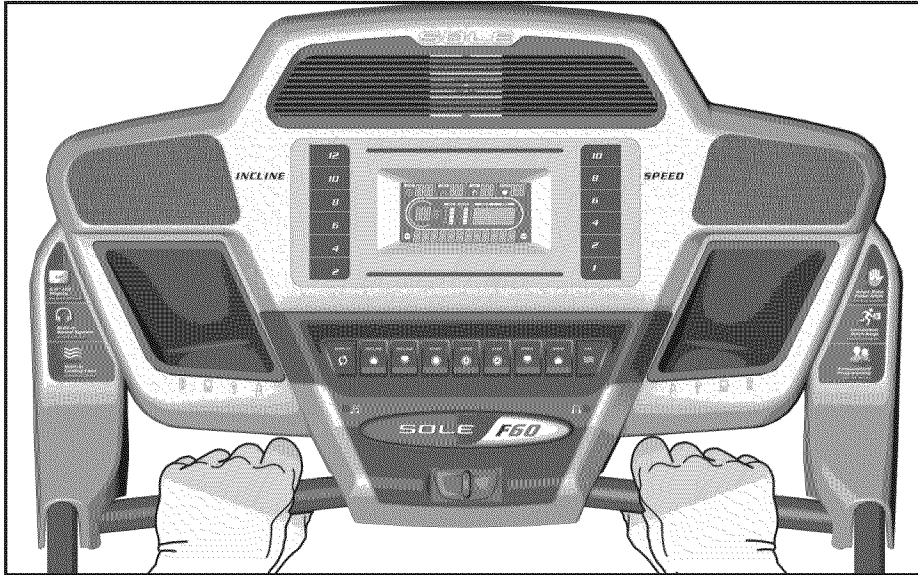

TURNING OFF TREADMILL

1. The display will automatically turn off – go to sleep - after 30 minutes of inactivity when in the Pause / Stop mode. Almost all power for the treadmill will be off except for some circuits that are needed to detect if any key is pressed, indicating the console should “wake up”. When the console is “asleep” the treadmill draws very little power, about as much as your television when it is turned off.
2. Removing the **Safety Key** is similar to entering “sleep” mode. Turning off the main power switch in the front of the treadmill will completely remove any power.

****ATTENTION****

Your new console comes configured in an in-store ‘Display Mode’ of operation, where the console will remain powered on unless the main power switch is turned off. To exit the display mode, for normal operation, press and hold the **Stop**, **Enter** and **Display** keys for 5 seconds; the display will show: Display mode - On. Use any of the **Program**, **Incline** or **Speed** ▲ keys to change the setting to Off then press **Enter**.

PROGRAMMABLE FEATURES

The F60 has ten built-in programs: one Manual program, five preset profiles, two user defined programs (**U1** & **U2**) and two Heart Rate programs (**HR1** & **HR2**).

Hill

The **Hill** program simulates going up and down a hill. The workload will steadily increase and then decrease during the program.

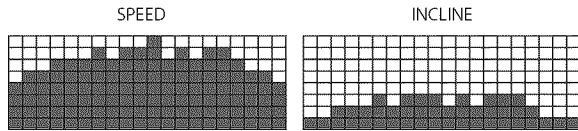

Fat Burn

The **Fat Burn** program is designed, as the name implies, to maximize the burning of fat. There are many schools of thought on the best way to burn fat but most experts agree that a lower exertion level that stays at a steady workload is the best. The absolute best way to burn fat is to keep your heart rate at around 60% to 70% of its maximum potential. This program does not use heart rate but simulates a lower, steady exertion workout.

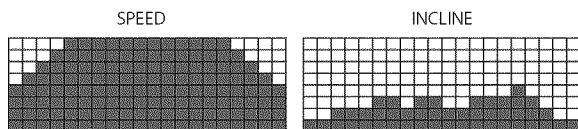

Cardio

The **Cardio** program is designed to increase your cardiovascular function and endurance. This is exercise for your heart and lungs. It will build up your heart muscle and increase blood flow and lung capacity. This is achieved by incorporating a higher level of exertion with slight fluctuations in work.

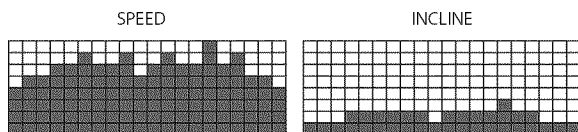

Strength

The **Strength** program is designed to increase muscular strength in your lower body. This program will steadily increase in workload to a high level and forces you to sustain it. This is designed to strengthen and tone your legs and glutes (muscles of the butt).

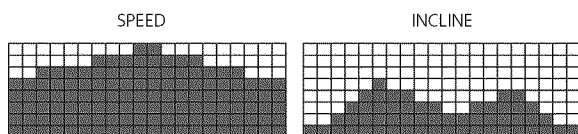

Interval

The Interval program takes you through high levels of intensity followed by periods of low intensity. This program increases your endurance by depleting your oxygen level followed by periods of recovery to replenish oxygen. Your cardiovascular system gets programmed to use oxygen more efficiently this way. This program also forces your body to become more efficient due to spikes in heart rate, between recovery periods. This aids in heart rate recovery from intense activities.

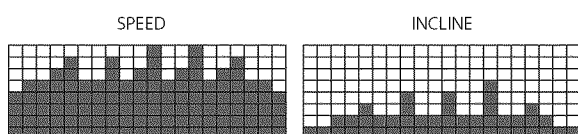

SELECTING A PROGRAM

1. Press the **Speed** ▲ / ▼ keys to view the programs on the screen then press the **Enter** key to select the program you would like to perform. The display will prompt you through the programming steps or you can just press the **Start** key to begin the program using the preset program values for age, weight and other program specific information.

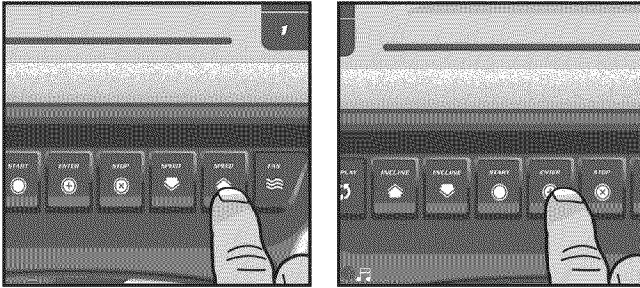

2. If **Enter** was pressed, the **Message Window** will display **Age**. You may use any of the ▲ / ▼ keys to adjust your age. After adjusting press the **Enter** key.
Note: You may press **Start** at any time during the programming to start the program with the information you've already input.
3. The **Message Window** will now be displaying a value, which is your body weight. Entering the correct body weight will affect the calorie count. Use any of the ▲ / ▼ keys to adjust, then press **Enter**.
 - **Calorie Display Note:** No exercise machine can give you an exact calorie count because there are too many factors which determine exact calorie burn for a particular person. Even if someone is the exact same body weight, age and height, their calorie burn may be very different than yours. The **Calorie** display is to be used as a reference only to monitor improvement from workout to workout.
4. The **Time Window** and **Message Window** will now be displaying a value, which is total workout time desired. Use any of the ▲ / ▼ keys to adjust, and then press **Enter**. After adjusting, press the **Enter** key.
5. The **Message Window** will display the preset max speed of the selected program. Use any of the ▲ / ▼ keys to adjust, and then press **Enter**. Each program has various speed changes throughout; this allows you to limit the highest speed the program will reach at it's peak.
6. Press **Start** to begin the program. The program will begin with a 3 minute warm-up. If you want to bypass this and go directly to the beginning of the program, press **Start** again.

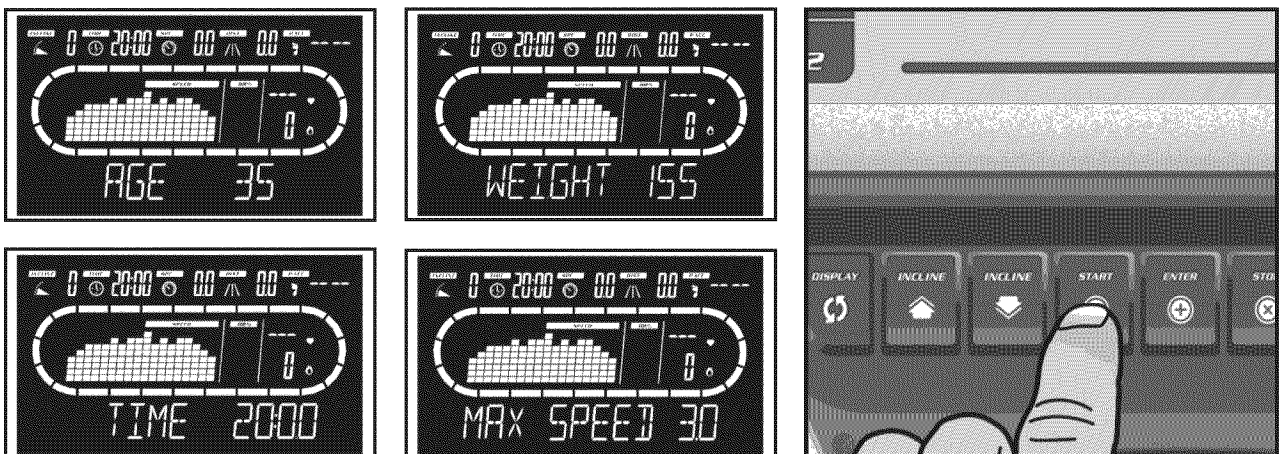

USER PROGRAMS

1. Select **User 1** or **User 2** via the **Speed** ▲ / ▼ keys then press **Enter**. Note that the dot matrix display portion will have a single row of dots at the bottom (Unless there is a previously stored program). If there is a program stored under the button that is pressed, it will be retrieved. If not, you have the option of programming in your first name. The **Message Window** will display and flash the letter "A". To change it, press the any ▲ key, then "B" will be displayed; if the any ▼ key is pressed, the letter "Z" will be displayed. After selecting the appropriate letter, press **Enter**. The letter "A" will again be displayed and blinking. Repeat the procedure until all letters of your first name are programmed (7 characters maximum). When your name is displayed, press **Stop** and it will be stored under either **User 1** or **User 2**.
2. Next the **Message Window** is flashing **Age**. Use the **Incline** ▲ / ▼ keys to adjust. Press **Enter**. This is a must to continue even if age is not adjusted.
3. The **Message Window** will now be blinking a body weight value. Enter your body weight and press **Enter**.
4. The **Time Window** and **Message Window** will now be blinking a **Time** value. Adjust the **Time** and press **Enter**.
5. The first column (segment) will now be blinking. Using the **Speed** ▲ / ▼ or **Quick** keys, adjust the speed level to your desired effort for the first segment then press **Enter**. The second column will now be blinking. Repeat the above process until all segments have been programmed. The first column will be blinking again. This is for the incline programming. Repeat the above process to program all segments for incline.
6. Press the **Start** button to begin the workout and also save the program to memory.

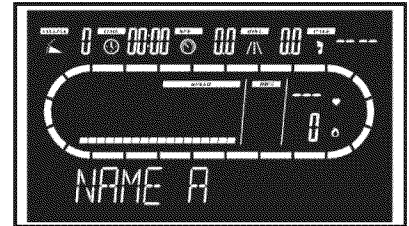
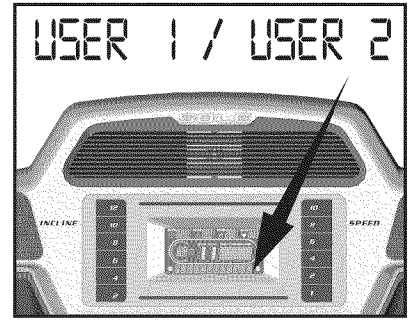

HEART RATE PROGRAMS

Before we get started, a word about Heart Rate:

The old motto, “no pain, no gain”, is a myth that has been overpowered by the benefits of exercising comfortably. A great deal of this success has been promoted by the use of heart rate monitors. With the proper use of a heart rate monitor, many people find that their usual choice of exercise intensity was either too high or too low and exercise is much more enjoyable by maintaining their heart rate in the desired benefit range.

To determine the benefit range in which you wish to train, you must first determine your Maximum Heart Rate. This can be accomplished by using the following formula: 220 minus your age. This will give you the Maximum Heart Rate (MHR) for someone of your age. To determine the effective heart rate range for specific goals you simply calculate a percentage your MHR. Your Heart rate training zone is 50% to 90% of your maximum heart rate. 60% of your MHR is the zone that burns fat while 80% is for strengthening the cardio vascular system. This 60% to 80% is the zone to stay in for maximum benefit.

For someone who is 40 years old their target heart rate zone is calculated:

$$\begin{aligned} 220 - 40 &= 180 \text{ (maximum heart rate)} \\ 180 \times .6 &= 108 \text{ beats per minute} \\ &\text{(60\% of maximum)} \\ 180 \times .8 &= 144 \text{ beats per minute} \\ &\text{(80\% of maximum)} \end{aligned}$$

So for a 40 year old the training zone would be 108 to 144 beats per minute.

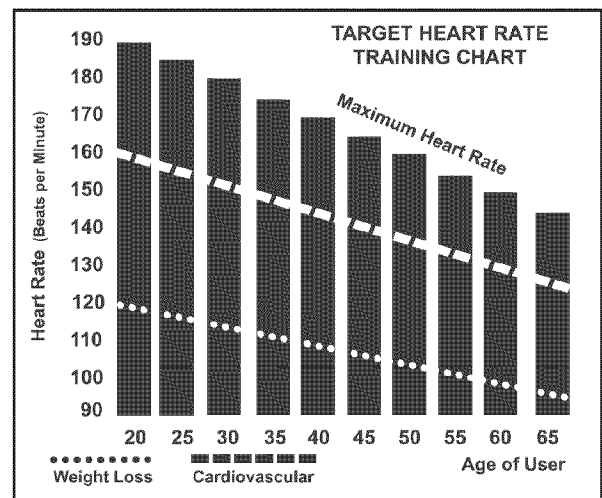

If you enter your age during programming the console will perform this calculation automatically. Entering your age is used for the Heart Rate programs. After calculating your MHR you can decide upon which goal you would like to pursue.

The two most popular reasons for, or goals, of exercise are cardiovascular fitness (training for the heart and lungs) and weight control. The black columns on the chart above represent the MHR for a person whose age is listed at the bottom of each column. The training heart rate, for either cardiovascular fitness or weight loss, is represented by two different lines that cut diagonally through the chart. A definition of the lines' goal is in the bottom left-hand corner of the chart. If your goal is cardiovascular fitness or if it is weight loss, it can be achieved by training at 80% or 60%, respectively, of your MHR on a schedule approved by your physician. Consult your physician before participating in any exercise program.

RATE OF PERCEIVED EXERTION

Heart rate is important but listening to your body also has a lot of advantages. There are more variables involved in how hard you should workout than just heart rate. Your stress level, physical health, emotional health, temperature, humidity, the time of day, the last time you ate and what you ate, all contribute to the intensity at which you should workout. If you listen to your body, it will tell you all of these things.

The rate of perceived exertion (RPE), also know as the Borg scale, was developed by Swedish physiologist G.A.V. Borg. This scale rates exercise intensity from 6 to 20 depending upon how you feel or the perception of your effort.

The scale is as follows:

Rating Perception of Effort

- 6 Minimal
- 7 Very,very light
- 8 Very,very light +
- 9 Very light
- 10 Very light +
- 11 Fairly light
- 12 Comfortable
- 13 Somewhat hard
- 14 Somewhat hard +
- 15 Hard
- 16 Hard +
- 17 Very hard
- 18 Very hard +
- 19 Very,very hard
- 20 Maximal

You can get an approximate heart rate level for each rating by simply adding a zero to each rating. For example a rating of 12 will result in an approximate heart rate of 120 beats per minute. Your RPE will vary depending up the factors discussed earlier. That is the major benefit of this type of training. If your body is strong and rested, you will feel strong and your pace will feel easier. When your body is in this condition, you are able to train harder and the RPE will support this. If you are feeling tired and sluggish, it is because your body needs a break. In this condition, your pace will feel harder. Again, this will show up in your RPE and you will train at the proper level for that day.

USING HEART RATE TRANSMITTER (SOLD SEPARATELY)

How to wear your wireless chest strap transmitter:

1. Attach the transmitter to the elastic strap using the locking parts.
2. Adjust the strap as tightly as possible as long as the strap is not too tight to remain comfortable.
3. Position the transmitter with the SOLE logo centered in the middle of your body facing away from your chest (some people must position the transmitter slightly left of center). Attach the final end of the elastic strap by inserting the round end and, using the locking parts, secure the transmitter and strap around your chest.
4. Position the transmitter immediately below the pectoral muscles.
5. Sweat is the best conductor to measure very minute heart beat electrical signals. However, plain water can also be used to pre-wet the electrodes (2 ribbed oval areas on the reverse side of the belt and both sides of the transmitter). It's also recommended that you wear the transmitter strap a few minutes before your work out. Some users, because of body chemistry, have a more difficult time in achieving a strong, steady signal at the beginning. After "warming up", this problem lessens. As noted, wearing clothing over the transmitter/strap doesn't affect performance.
6. Your workout must be within range - distance between transmitter/receiver - to achieve a strong steady signal. The length of range may vary somewhat but generally stay close enough to the console to maintain good, strong, reliable readings. Wearing the transmitter immediately against bare skin assures you of proper operation. If you wish, you may wear the transmitter over a shirt. To do so, moisten the areas of the shirt that the electrodes will rest upon.

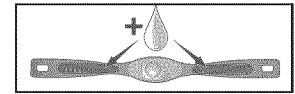
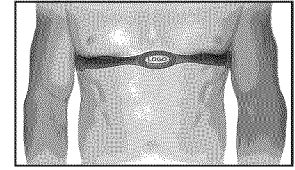

Note: The transmitter is automatically activated when it detects activity from the user's heart. Additionally, it automatically deactivates when it does not receive any activity. Although the transmitter is water resistant, moisture can have the effect of creating false signals, so you should take precautions to completely dry the transmitter after use to prolong battery life (estimated transmitter battery life is 2500 hours). The replacement battery is Panasonic CR2032.

ERRATIC OPERATION

Caution! Do not use this treadmill for Heart Rate unless a steady, solid Actual Heart Rate value is being displayed. High, wild, random numbers being displayed indicate a problem.

Areas to look for interference which may cause erratic heart rate:

1. Microwave ovens, TV's, small appliances, etc.
2. Fluorescent lights.
3. Some household security systems.
4. Perimeter fence for a pet.
5. Some people have problems with the transmitter picking up a signal from their skin. If you have problems try wearing the transmitter upside down. Normally the transmitter will be oriented so the SOLE logo is right side up.
6. The antenna that picks up your heart rate is very sensitive. If there is an outside noise source, turning the whole machine 90 degrees may de-tune the interference.
7. Loose treadmill console or bolts in the upright tube.
8. Another Individual wearing a transmitter within 3' of your machine's console.

If you continue to experience problems contact your dealer.

WARNING! - DO NOT USE THE HEART RATE PROGRAM IF YOUR HEART RATE IS NOT REGISTERING PROPERLY ON THE TREADMILL'S DISPLAY!

HEART RATE PROGRAMMING

CAUTION!

Heart Rate programs are intended for wireless transmitter chest strap only. Do not use **Pulse Grip** bar for **Heart Control**. You must receive a strong/steady value in the **Heart Rate Window** (See Using Heart Rate Transmitter section for instructions on how to use).

The **HR1** program has a default level that is 60% of your projected heart rate maximum. This program is geared for individuals with fat loss as a goal. The **HR2** program has a default of 80% of your projected heart rate maximum. It is geared for individuals with a goal of improving cardiovascular & lung function.

1. Select **HR1** or **HR2** via the **Speed** ▲ / ▼ keys then press **Enter**.
2. The **Message Window** will now be blinking showing user's age. Adjust and press **Enter** or press **Enter** to accept the default value. Adjusting **Age** will change the Target HR value.
3. The **Message Window** will be blinking, showing the default user's bodyweight for this program. You may adjust it and press **Enter** if you want or just press **Enter** to accept the default value.
4. Now you are asked to adjust the **HR1** or **HR2** value. The default is 60% (**HR1**); $(220 - \text{age} \times .60)$; or 80% (**HR2**); $(220 - \text{age} \times .80)$. You may select a higher or lower number also. Adjust the number by pressing the **Speed** ▲ / ▼ keys and press **Enter** to continue.
5. The **Time Window** and **Message Window** will now be blinking. Adjust the time and press **Enter**.
6. Now you are finished editing the settings and can begin your workout by pressing the **Start** key. You can also go back and modify your settings by pressing the **Stop** key to go back one level, or screen.
7. If you want to increase or decrease the speed at any time during the program press the **Speed** ▲ / ▼ keys.
8. During the HR program you will be able to scroll through the data in the **Message Window** by pressing the **Display** key. When the program ends the **Message Window** will show a summary of your workout. The summary will be displayed for a short time then the console will return to the start-up display.
9. Press **Start** to begin program.

The program will now control the treadmill to steadily increase your heart rate to the target value. This process is automatic and could take upwards of five minutes, depending on how far your HR needs to go and what kind of physical shape you are in. People who are more fit will take longer to reach the target.

GENERAL MAINTENANCE

BELT & DECK

Your treadmill uses a very high-efficient low-friction deck. Performance is maximized when the deck is kept as clean as possible. Use a soft, damp cloth, or paper towel, wipe the edge of the belt and the area between the belt edge and the frame. Also reach as far as practical directly under the belt edge. This should be done once a month to extend belt and bed life. A mild soap and water solution along with a nylon scrub brush will clean the top of the textured belt. **Allow to dry before using.**

BELT DUST

This occurs during normal break-in or until the belt stabilizes. Sometimes the black dust from the belt will appear on the floor behind the treadmill, this is normal.

GENERAL CLEANING (Use the chart on Pg. 5 to record your maintenance)

Dirt, dust, and hair can block air inlets and accumulate on the running belt. Please vacuum underneath your treadmill on a monthly basis to prevent excess build-up of dirt that can get sucked up and get into the inner workings under the motor cover. Every other month, you should remove the motor cover and carefully vacuum out dirt and hair that may accumulate. **UNPLUG THE POWER CORD BEFORE THIS TASK.**

BELT ADJUSTMENTS

Tread-belt Tension Adjustment - Belt tension is not critical for most users. It is very important though for joggers and runners in order to provide a smooth, steady running surface.

Adjustment must be made from the rear roller with the M6 L Allen wrench (**99**) provided in the parts package. The adjustment bolts are located at the end of the step rails as shown in the diagram below. **Note:** Adjustment is through small hole in end cap.

Tighten the rear roller only enough to prevent slippage at the front roller. Turn the tread-belt tension adjusting bolts 1/4 turn each and inspect for proper tension by walking on the belt and making sure it is not slipping or hesitating with each step. When an adjustment is made to the belt tension, you must be sure to turn the bolts on both sides evenly or the belt could start tracking to one side instead of running in the middle of the deck.

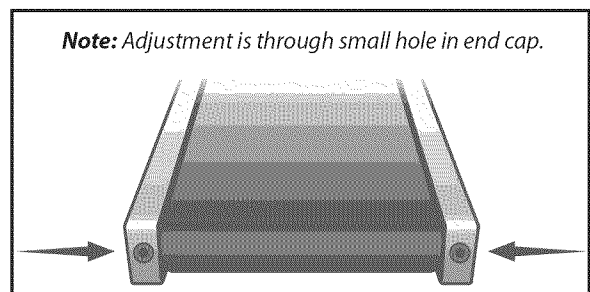

DO NOT OVERTIGHTEN – Over tightening will cause belt damage and premature bearing failure. If you tighten the belt a lot and it still slips, the problem could actually be the drive belt - located under the motor cover - that connects the motor to the front roller. If that belt is loose it feels similar to the walking belt being loose. Tightening the motor belt should be done by a trained service person.

TREAD-BELT TRACKING ADJUSTMENT

The treadmill is designed so that the tread-belt remains reasonably centered while in use. It is normal for some belts to drift near one side while in use, depending on a user's gait and if they favor one leg. But if during use the belt continues to move toward one side, adjustments are necessary.

TO SET TREAD-BELT TRACKING

A 6 mm Allen wrench (99) is provided for this adjustment. Make tracking adjustments on the left side bolt. Set belt speed at 3 mph. Be aware that a small adjustment can make a dramatic difference which may not be apparent right away. If the belt is **too close to the left side**, then turn the bolt only a 1/4 turn to the right (clockwise) and wait a few minutes for the belt to adjust itself.

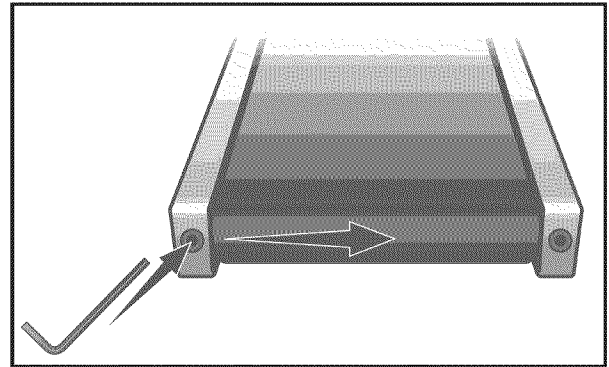

Continue to make 1/4 turns until the belt stabilizes in the center of the running deck.

If the belt is **too close to the right side**, turn the bolt counter-clockwise. The belt may require periodic tracking adjustment depending on use and walking/running characteristics. Some users may affect tracking differently. Expect to make adjustments as required to center the tread-belt. Adjustments will become less of a maintenance concern as the belt is used. Proper belt tracking is an owner responsibility common with all treadmills.

ATTENTION:

DAMAGE TO THE RUNNING BELT RESULTING FROM IMPROPER TRACKING / TENSION ADJUSTMENTS IS NOT COVERED UNDER THE SOLE WARRANTY.

BELT/DECK LUBRICATION

First, you want to clean between the belt and deck to remove any debris that may be trapped. Use a clean, non-fraying rag, t-shirt, or light towel. Halfway between the end of the treadmill and motor cover, shove the garment under the belt until you can grasp it on both sides of the belt. Drag the garment the length of the entire belt 1-2 times. Remove the garment.

Do not lubricate with anything other than Sole Fitness approved lubricant. Your treadmill comes with one tube of "Lube" and extra tubes can be ordered directly from Sole Fitness or your authorized Sole Fitness dealer. You may also use a Lube-n-Walk kit that can be purchased through both aforementioned sellers.

Keeping the deck lubricated at the recommended intervals ensures the longest life possible for your treadmill. If the lubricant dries out, the friction between the belt and deck rises and places undue stress on the drive motor, drive belt and electronic motor control board, which could result in catastrophic failure of these expensive components. Failure to lubricate the deck at regular intervals may void the warranty.

The belt & deck come pre-lubricated and subsequent lubrication should be performed every 90 hours of use or if you notice that the deck is dry. It is recommended that you reach between the belt and deck to verify there is lubrication present, every other month. If you check and there isn't any lubrication present, follow the procedure below even though the "Lube" indicator isn't lit on the console. Otherwise, lubricate when the console's lubrication reminder lights after 90 hours of use. Use the following procedure to apply the silicone lubricant:

1. Turn the power switch off and unplug the power cord from the wall outlet
2. Measure 18" from the edge of the motor cover; kneel down and reach under the belt approximately 4- 6" from one edge. Squirt a line of lubricant about 1/8" wide x 15" long in an "S" pattern perpendicular to the motor cover.
3. Repeat the process on the opposite side.
4. Plug the electrical cord back into the outlet and turn the power switch on.
5. Walk on the belt at a moderate speed for five minutes to evenly distribute the silicone lube.
6. If the "Lube" message appears on the console, perform the following procedure to reset the message:
 1. To enter the Engineering Mode Menu press and hold down the **Start**, **Stop** and **Enter** keys, then at the same time insert the **Safety Key**. Keep holding the keys down until the **Message Window** displays Engineering Mode Menu. Press the **Enter** button to access.
 2. Press the **Speed ▲** button (or **Speed ▼** button to go backwards) until "Functions" appears; press **Enter**.
 3. Press the **Speed ▲** button until "Maintenance" message appears; press **Enter** to reset the lube message.
 4. Press **Stop** to exit Engineering Mode and resume use of your treadmill.

SERVICE CHECKLIST - DIAGNOSIS GUIDE

Before contacting your dealer for aid, please review the following information. It may save you both time and expense. This list includes common problems that may not be covered under the treadmill's warranty.

PROBLEM	SOLUTION/CAUSE
Display does not light	<ol style="list-style-type: none"> 1. Tether cord not in position. 2. Circuit breaker on front grill tripped. Push circuit breaker in until it locks. 3. Plug is disconnected. Make sure plug is firmly pushed into AC household wall outlet. 4. Household circuit breaker may be tripped. 5. Treadmill defect. Contact your SOLE dealer.
Tread-belt does not stay centered Treadmill belt hesitates when walked/run on	<p>The user may be walking while favoring or putting more weight on either the left or right foot. If this walking pattern is natural, track the belt slightly off-center to the side opposite from the belt movement. See General Maintenance section on Tread-belt Tension. Adjust as necessary.</p>
Motor is not responsive after pressing Start	<ol style="list-style-type: none"> 1. If the belt moves, but stops after a short time and the display shows "LS", run calibration. 2. If you press Start and the belt never moves, then the display shows LS, contact service.
Treadmill will only achieve approximately 7 mph but shows higher speed on display	<p>This indicates motor should be receiving power to operate. Low AC voltage to treadmill. Do not use an extension cord. If an extension cord is required it should be as short as possible and heavy duty 16 gauge minimum. Low household voltage. Contact an electrician or your SOLE dealer. A minimum of 110 volt AC current is required.</p>
Tread-belt stops quickly/suddenly when tether cord is pulled	<p>High belt/deck friction. See General Maintenance section on lubrication.</p>
Treadmill trips on board 15 amp circuit	<p>High belt/deck friction. See General Maintenance</p>
Computer shuts off when console is touched (on a cold day) while walking/running	<p>Treadmill may not be grounded. Static electricity is "crashing" the computer. Refer to Grounding Instructions on page 3.</p>
House circuit breaker trips, but not the treadmill fuse	<p>Need to replace the house breaker with a "High In-rush current" type breaker (see page 3 for details)</p>

CALIBRATION PROCEDURE

1. Remove the **Safety Key**.
2. Press and hold down the **Start** and **Speed ▲** buttons and replace the **Safety Key**. Continue to hold the **Start** and **Speed ▲** key until the window displays “Factory settings”, then press the **Enter** key.
3. You will now be able to set the display to show Metric or English settings (Miles vs. Kilometers). To do this, press the **▲ / ▼** key to show which you want, then press **Enter**.
4. Make sure the wheel size diameter is 1.83 then press **Enter**.
5. Adjust the minimum speed (if needed) to 0.5 and then press **Enter**.
6. Adjust the maximum speed (if needed) to 10.0 and then press **Enter**.
7. Adjust the maximum elevation (if needed) to 15 and then press **Enter**.
8. Grade return – On (This allows the incline to return to zero when **Stop** is pressed. For sale in Europe, EU standards require this to be off)
9. Press **Start** to begin calibration. The process is automatic; the speed will start up without warning, so do not stand on the belt.

ADJUSTING THE SPEED SENSOR

If the calibration does not pass you may need to check the speed sensor alignment.

1. Remove the motor cover hood by loosening the 4 screws that hold it in place (you do not need to remove them completely).
2. The speed sensor is located on the left side of the frame, right next to the front roller pulley (the pulley will have a belt around it that also goes to the motor). The speed sensor is small and black with a wire connected to it.
3. Make sure the sensor is as close as possible to the pulley without touching it. You will see a magnet on the face of the pulley; make sure the sensor is aligned with the magnet. There is a screw that holds the sensor in place that needs to be loosened to adjust the sensor. Re-tighten the screw when finished.

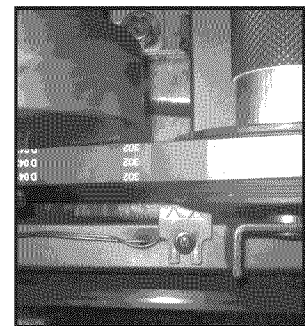

MAINTENANCE MENU

1. Press and hold the **Start**, **Stop** and **Enter** key at the same time, until the display shows “Engineering mode” (it may say maintenance menu, depending on version). Press the **Enter** key.
2. You can now scroll through the menu using the **Speed ▲ / ▼** keys. Use the **Stop** key to return to previous menu selection. The menu selections are:
 - A. **Key Test** - Will allow you to test all the keys to make sure they are functioning
 - B. **Display Test** - Tests all the display functions
 - C. **Functions** - Press **Enter** to access settings, use **Speed ▲ / ▼** keys to scroll
 - I. **Display Mode** - Turn off to have the console power down automatically after 30 minutes of inactivity
 - II. **Pause Mode** - Turned on to allow 5 minutes of pause, turn off to have console pause in indefinitely
 - III. **Maintenance** - Reset lube message and odometer readings
 - IV. **Units** - Choose from English or Metric display readings
 - V. **Key Tone** - Will turn on/off beeping noise that is made when keys are pressed.
 - D. **Security** - Allows you to lock the keypad so no unauthorized use of the machine is allowed. When the child lock is enabled, the console will not allow the keypad to operate unless you press and hold the **Start** and **Enter** buttons for 3 seconds to unlock the console.
 - E. **Exit**

MANUFACTURER'S LIMITED WARRANTY

TREADMILL WARRANTY

Effective August 1, 2012

SOLE warrants all its treadmills' parts, for a period of time listed below, from the date of retail sale, as determined by sale receipt, or in the absence of a receipt eighteen (18) months from the original factory shipping date. SOLE's responsibilities include providing new or remanufactured parts, at SOLE's option, and technical support to our independent dealers and servicing organizations. In the absence of a dealer or service organization, these warranties will be administered by SOLE directly to a consumer. The warranty period applies to the following components:

Drive Motor	Lifetime
Deck	3 Years
All Other Components	3 years
Frame Weldments	Lifetime
Labor	1 Year
Cosmetic Items *	90 Days

*Cosmetic items including, but not limited to the following: grips, console overlays, and labels/decals.

NORMAL RESPONSIBILITIES OF THE CONSUMER

This warranty applies only to products in ordinary household use, and the consumer is responsible for the items listed below:

1. The warranty registration card must be completed and returned to the address listed on the card within 10 days of the original purchase to validate the manufacturer's limited warranty.
2. Proper use of the treadmill in accordance with the instructions provided in this manual, including belt tracking.
3. Proper installation in accordance with instructions provided with the treadmill and with all local electric codes.
4. Proper connection to a grounded power supply of sufficient voltage, replacement of blown fuses, repair of loose connections or defects in house wiring.
5. Expenses for making the treadmill accessible for servicing, including any item that was not part of the treadmill at the time it was shipped from the factory.
6. Damages to the treadmill finish during shipping, installation or following installation.
7. Routine maintenance of this unit as specified in this manual.

EXCLUSIONS

This warranty does not cover the following:

1. CONSEQUENTIAL, COLLATERAL, OR INCIDENTAL DAMAGES SUCH AS PROPERTY DAMAGE AND INCIDENTAL EXPENSES RESULTING FROM ANY BREACH OF THIS WRITTEN OR ANY IMPLIED WARRANTY.
Note: Some states do not allow the exclusion or limitation of incidental or consequential damages, so this limitation or exclusion may not apply to you.
2. Service call reimbursement to the consumer. Service call reimbursement to the dealer that does not involve malfunction or defects in workmanship or material, for units that are beyond the warranty period, for units that are beyond the service call reimbursement period, for treadmill not requiring component replacement, or treadmill not in ordinary household use.
3. Damages caused by services performed by persons other than authorized SOLE service companies; use of parts other than original SOLE parts; or external causes such as corrosion, discoloration of paint or plastic, alterations, modifications, abuse, misuse, accident, improper maintenance, inadequate power supply, or acts of God.
4. Products with original serial numbers that have been removed or altered.
5. Products that have been: sold, transferred, bartered, or given to a third party.
6. Products that do not have a warranty registration card on file at SOLE. SOLE reserves the right to request proof of purchase if no warranty record exists for the product.
7. THIS WARRANTY IS EXPRESSLY IN LIEU OF ALL OTHER WARRANTIES EXPRESSED OR IMPLIED, INCLUDING THE WARRANTIES OF MERCHANTABILITY AND/OR FITNESS FOR A PARTICULAR PURPOSE.
8. Product use in any environment other than a residential setting.
9. Warranties outside of North America may vary. Please contact your local dealer for details.

SERVICE

Keep your bill of sale. Twelve (12) months from the date on the bill of sale or eighteen (18) months from the date of factory shipping as determined by the serial number establishes the labor warranty period should service be required. If service is performed, it is in your best interest to obtain and keep all receipts. This written warranty gives you specific legal rights. You may also have other rights that vary from state to state. Service under this warranty must be obtained by following these steps, in order:

1. Contact your selling authorized SOLE dealer. OR
2. Submit all service requests including serial number, contact information and a brief description of the problem online at www.soletreadmills.com/technical.php?p=service.
3. If you have any questions about your new product or questions about the warranty contact SOLE Fitness at 1-866-780-SOLE (7653). If you have a technical problem with your new treadmill contact SOLE technical service at 866-MYSOLE1 (697-6531). If purchased at Sears: 1-800-469-4663.
4. If no local service is available, SOLE will repair or replace the parts, at SOLE's option, within the warranty period at no charge for parts. All transportation costs, both to our factory and upon return to the owner, are the responsibility of the owner. The owner is responsible for adequate packaging upon return to SOLE. SOLE is not responsible for damages that occur during shipping. Make all freight damage claims with the appropriate freight carrier. DO NOT SHIP ANY UNIT TO OUR FACTORY WITHOUT A RETURN AUTHORIZATION NUMBER. All units arriving without a return authorization number will be refused.
5. For any further information, or to contact our service department by mail, send your correspondence to:

SOLE Fitness
P.O. Box 2037
Jonesboro, AR 72402-2037

Product features or specifications as described or illustrated are subject to change without notice. All warranties are made by SOLE.

Get it fixed, at your home or ours!

Your Home

For repair—**in your home**—of **all** major brand appliances, lawn and garden equipment, or heating and cooling systems, **no matter who made it, no matter who sold it!**

For the replacement parts, accessories, and user's manuals that you need to do-it-yourself.

For Sears professional installation of home appliances and items like garage door openers and water heaters.

1-800-4-MY-HOME® (1-800-469-4663)

Call anytime, day or night (U.S.A. and Canada)

www.sears.com

www.sears.ca

Our Home

For repair of carry-in items like vacuums, lawn equipment, and electronics, call or go on-line for the location of your nearest **Sears Parts & Repair Center.**

1-800-488-1222 Call anytime, day or night (U.S.A. only)

www.sears.com

To purchase a protection agreement (U.S.A.) or maintenance agreement (Canada) on a product serviced by Sears:

1-800-827-6655 (U.S.A.)

1-800-361-6665 (Canada)

Para pedir servicio de reparación a domicilio, y para ordenar piezas:

1-888-SU-HOGAR® (1-888-784-6427)



® Registered Trademark / ™ Trademark / ℠ Service Mark of Sears Brands, LLC
© Marca Registrada / ™ Marca de Fábrica / ℠ Marca de Servicio de Sears Brands, LLC

1 YEAR FULL WARRANTY

If this Sears/Sole exercise equipment fails due to a defect in material or workmanship within 1 year of the date of purchase, call 1-800-4-MY-HOME® (1-800-469-4663) to arrange for free repair (or replacement if repair proves impossible). The drive motor is warranted for lifetime from the date of purchase.

Please see full Sole warranty page in the owner's manual for complete warranty details.

This warranty does not apply when the Treadmill Exerciser is used commercially or for rental purposes.

This warranty gives you specific legal rights, and you may also have other rights which vary from state to state.

Sears, Roebuck and Co., Hoffman Estates, IL 60179

SOLE

FITNESS