

Panasonic®

Owner's Manual Home Theater Audio System

Model No. SC-HTB350
SC-HTB351

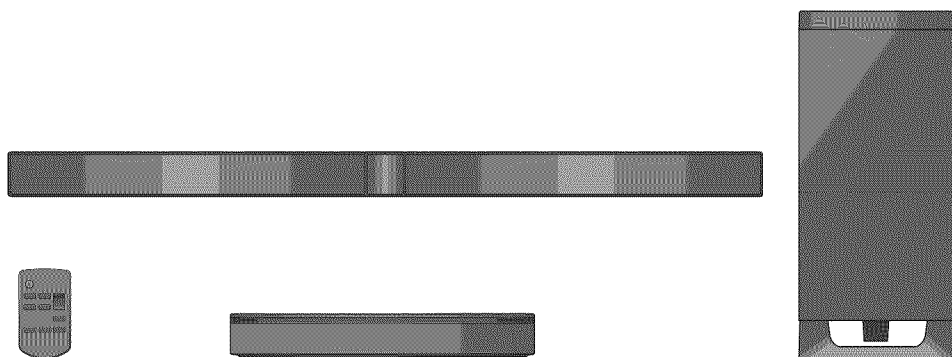

Thank you for purchasing this product.
For optimum performance and safety, please read these instructions carefully.
Please keep this manual for future reference.

If you have any questions, contact:
U.S.A. and Puerto Rico: 1-800-211-PANA (7262)

IMPORTANT SAFETY INSTRUCTIONS

Read these operating instructions carefully before using the unit. Follow the safety instructions on the unit and the applicable safety instructions listed below. Keep these operating instructions handy for future reference.

- 1 Read these instructions.
- 2 Keep these instructions.
- 3 Heed all warnings.
- 4 Follow all instructions.
- 5 Do not use this apparatus near water.
- 6 Clean only with dry cloth.
- 7 Do not block any ventilation openings. Install in accordance with the manufacturer's instructions.
- 8 Do not install near any heat sources such as radiators, heat registers, stoves, or other apparatus (including amplifiers) that produce heat.
- 9 Do not defeat the safety purpose of the polarized or grounding-type plug. A polarized plug has two blades with one wider than the other.
A grounding-type plug has two blades and a third grounding prong. The wide blade or the third prong are provided for your safety. If the provided plug does not fit into your outlet, consult an electrician for replacement of the obsolete outlet.
- 10 Protect the power cord from being walked on or pinched particularly at plugs, convenience receptacles, and the point where they exit from the apparatus.
- 11 Only use attachments/accessories specified by the manufacturer.
- 12 Use only with the cart, stand, tripod, bracket, or table specified by the manufacturer, or sold with the apparatus. When a cart is used, use caution when moving the cart/apparatus combination to avoid injury from tip-over.
- 13 Unplug this apparatus during lightning storms or when unused for long periods of time.
- 14 Refer all servicing to qualified service personnel. Servicing is required when the apparatus has been damaged in any way, such as power-supply cord or plug is damaged, liquid has been spilled or objects have fallen into the apparatus, the apparatus has been exposed to rain or moisture, does not operate normally, or has been dropped.



WARNING

Unit

- To reduce the risk of fire, electric shock or product damage,
 - Do not expose this unit to rain, moisture, dripping or splashing.
 - Do not place objects filled with liquids, such as vases, on this unit.
 - Use only the recommended accessories.
 - Do not remove covers.
 - Do not repair this unit by yourself. Refer servicing to qualified service personnel.

Button-type battery (Lithium battery)

- Risk of fire, explosion and burns. Do not disassemble, heat above 60 °C (140 °F) or incinerate.

If any electrolyte should come into contact with your hands or clothes, wash it off thoroughly with water.

If any electrolyte should come into contact with your eyes, never rub the eyes. Rinse eyes thoroughly with water, and then consult a doctor.

<For USA-California only>

This product contains a CR Coin Cell Lithium Battery which contains Perchlorate Material – special handling may apply.

See www.dtsc.ca.gov/hazardouswaste/perchlorate.

CAUTION

Unit

- Do not place sources of naked flames, such as lighted candles, on this unit.

Placement

- To reduce the risk of fire, electric shock or product damage,
 - Do not install or place this unit in a bookcase, built-in cabinet or in another confined space. Ensure this unit is well ventilated.
 - Do not obstruct this unit's ventilation openings with newspapers, tablecloths, curtains, and similar items.

Button-type battery (Lithium battery)

- Danger of explosion if battery is incorrectly replaced. Replace only with the type recommended by the manufacturer.
- When disposing of the batteries, please contact your local authorities or dealer and ask for the correct method of disposal.
- Insert with poles aligned.
- Do not touch the terminals (+ and –) with metal objects.
- Do not recharge, disassemble, remodel, heat or throw into fire.
- Keep out of reach of children.
- Mishandling of batteries can cause electrolyte leakage and may cause a fire.
 - Remove the battery if you do not intend to use the remote control for a long period of time. Store in a cool, dark place.
- Do not heat or expose to flame.
- Do not leave the battery(ies) in a car exposed to direct sunlight for a long period of time with doors and windows closed.



CAUTION

RISK OF ELECTRIC SHOCK

DO NOT OPEN



CAUTION: TO REDUCE THE RISK OF ELECTRIC SHOCK, DO NOT REMOVE SCREWS. NO USER-SERVICEABLE PARTS INSIDE. REFER SERVICING TO QUALIFIED SERVICE PERSONNEL.



The lightning flash with arrowhead symbol, within an equilateral triangle, is intended to alert the user to the presence of uninsulated "dangerous voltage" within the product's enclosure that may be of sufficient magnitude to constitute a risk of electric shock to persons.



The exclamation point within an equilateral triangle is intended to alert the user to the presence of important operating and maintenance (servicing) instructions in the literature accompanying the appliance.

THE FOLLOWING APPLIES ONLY IN THE U.S.A.

This device complies with Part 15 of the FCC Rules. Operation is subject to the following two conditions:

(1) This device may not cause harmful interference, and

(2) this device must accept any interference received, including interference that may cause undesired operation.

This transmitter must not be co-located or operated in conjunction with any other antenna or transmitter.

This product is restricted to indoor use due to its operation in the 5.150 GHz to 5.250 GHz and 5.725 GHz to 5.850 GHz frequency range.

FCC require this product to be used indoors for the frequency range 5.150 GHz to 5.250 GHz to reduce the potential for harmful interference to co-channel Mobile Satellite systems. High power radars are allocated as primary users of the 5.25 GHz to 5.35 GHz and 5.65 GHz to 5.85 GHz bands. These radar stations can cause interference with and/or damage this product.

This equipment complies with FCC radiation exposure limits set forth for an uncontrolled environment and meets the FCC radio frequency (RF) Exposure Guidelines in Supplement C to OET65. This equipment has very low levels of RF energy that is deemed to comply without maximum permissive exposure evaluation (MPE). But it is desirable that it should be installed and operated keeping the radiator at least 20 cm (7 7/8") or more away from person's body (excluding extremities: hands, wrists, feet and ankles).

THE FOLLOWING APPLIES ONLY IN THE U.S.A.

FCC Note:

This equipment has been tested and found to comply with the limits for a Class B digital device, pursuant to Part 15 of the FCC Rules.

These limits are designed to provide reasonable protection against harmful interference in a residential installation. This equipment generates, uses and can radiate radio frequency energy and, if not installed and used in accordance with the instructions, may cause harmful interference to radio communications.

However, there is no guarantee that interference will not occur in a particular installation. If this equipment does cause harmful interference to radio or television reception, which can be determined by turning the equipment off and on, the user is encouraged to try to correct the interference by one or more of the following measures:

- Reorient or relocate the receiving antenna.
- Increase the separation between the equipment and receiver.
- Connect the equipment into an outlet on a circuit different from that to which the receiver is connected.
- Consult the dealer or an experienced radio/TV technician for help.

Any unauthorized changes or modifications to this equipment would void the user's authority to operate this device.

This device complies with Part 15 of the FCC Rules. Operation is subject to the following two conditions:

(1) This device may not cause harmful interference, and

(2) this device must accept any interference received, including interference that may cause undesired operation.

Responsible Party:
Panasonic Corporation of North America
One Panasonic Way,
Secaucus, NJ 07094

Support Contact:
Panasonic Consumer Marketing Company of North America
Telephone No.: 1-800-211-PANA (7262)

Table of contents

IMPORTANT SAFETY INSTRUCTIONS	2
-------------------------------------	---

Before use

Supplied items	5
System (SC-HTB350/SC-HTB351)	5
Accessories	5
Control reference guide	6
Main unit and active subwoofer (Front)	6
Main unit and active subwoofer (Rear)	6
Remote control	7

Getting started

Step 1 Selecting the placement method	8
Speaker system	9
Active subwoofer	9
Wireless interference	9
Step 2 Assembling the speakers	10
When attaching the speakers to a wall	10
When placing the speakers on a table	14
Additional speaker fall prevention measures	17
Step 3 Connections	19
Connection with the TV	19
Connection with other devices	19
Speaker cable connection	20
AC power supply cord connection	20
Active subwoofer wireless connection	21
Bluetooth® connection	21

Operations

Using this unit	22
3D sound	23
Audio output modes	23
Advanced operations	24

Reference

Troubleshooting	26
About Bluetooth®	27
Indicator illumination	28
Specifications	29
Limited Warranty (ONLY FOR U.S.A. AND PUERTO RICO)	31
Unit care	Back cover

- The illustrations shown may differ from your unit.
- Operations in this Owner's Manual are described mainly with the remote control, but you can perform the operations on the main unit if the controls are the same.



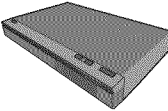
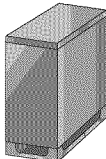
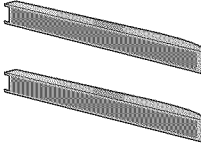

Supplied items

System (SC-HTB350/SC-HTB351)

<input type="checkbox"/> 1 Main unit (SU-HTB350) 	<input type="checkbox"/> 1 Active subwoofer (SB-HWA350) 	<input type="checkbox"/> 2 Front speakers (SB-HTB350) 
---	--	--

Accessories

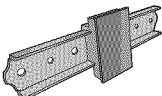
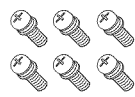
Check the supplied accessories before using the system.

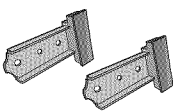
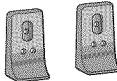
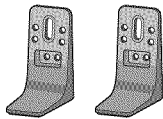
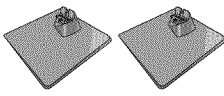
<input type="checkbox"/> 1 Remote control (with a battery) (N2QAYC000063) 	<input type="checkbox"/> 2 AC power supply cords (K2CB2YY00059) 	<input type="checkbox"/> 2 Speaker cables (REEX1266A: RED) (REEX1267A: WHITE) Length: 3 m (9.8 ft) 	<input type="checkbox"/> 1 Speaker joint (RAQ0085) 
<input type="checkbox"/> 6 Screws (XYN5+J14FJK) 	<input type="checkbox"/> 2 Speaker feet (RKAX0028-K) 	<input type="checkbox"/> 2 Front ornaments (RAQ0089) 	<input type="checkbox"/> 2 Support legs (RYQ0970-K) 
<input type="checkbox"/> 2 Stands (RYQ0853-KJ) 	<input type="checkbox"/> 2 Speaker bases (RAQ0086) 		



- Product numbers are correct as of December 2011. These may be subject to change.
- To order accessories, refer to "Accessory Purchases (United States and Puerto Rico)" on page 31.
- The supplied AC power supply cord is for use with this unit and the active subwoofer only. Do not use it with other equipment. Also, do not use cords from other equipment with this unit or active subwoofer.

Control reference guide

Main unit and active subwoofer (Front)

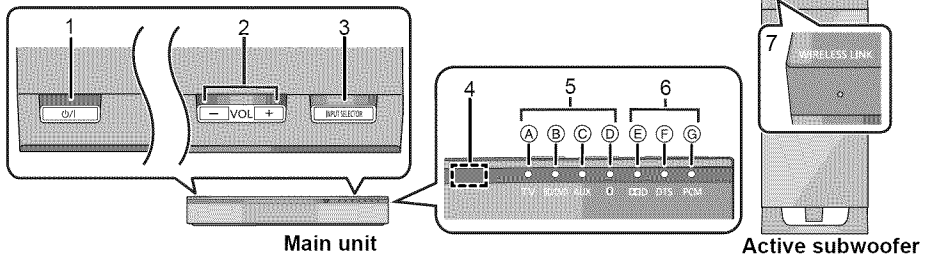

- 1 **Standby/on switch (⏻/⏻)**
Press to switch the unit from on to standby mode or vice versa. In standby mode, the unit is still consuming a small amount of power.
- 2 Adjust the volume of the speakers
- 3 Select the input source
"TV" → "BD/DVD" → "AUX"
↑ "MUTE" ↓
- 4 Remote control signal sensor (⇒ 7)
- 5 Input selector indicators*1
 - Ⓐ TV indicator
Lights green when the TV is the audio source
 - Ⓑ BD/DVD indicator
Lights amber when the device connected to the BD/DVD terminal is the audio source
 - Ⓒ AUX indicator
Lights amber when the device connected to the AUX terminal is the audio source
 - Ⓓ Bluetooth® indicator
Lights blue when the Bluetooth® device is the audio source
- 6 Audio format indicators*1
 - Ⓔ Dolby Digital indicator
Lights when Dolby Digital is the current audio format
 - Ⓕ DTS indicator
Lights when DTS is the current audio format
 - Ⓖ PCM indicator
Lights when PCM (2ch, Multi-channel) is the current audio format
- 7 WIRELESS LINK indicator (⇒ 21)

Main unit and active subwoofer (Rear)

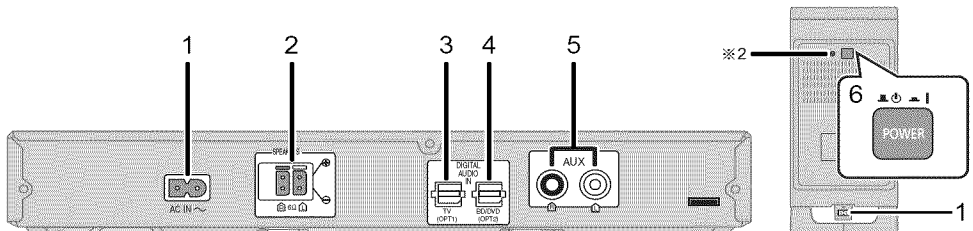

- 1 AC IN terminal (⇒ 20)
- 2 Speaker terminals (⇒ 20)
- 3 TV terminal (⇒ 19)
- 4 BD/DVD terminal (⇒ 19)
- 5 AUX terminal (⇒ 19)
- 6 Active subwoofer on/off button

※1 The indicators will also blink in various conditions (⇒ 28)

※2 The I/D SET button is only used when the main unit is not paired with the active subwoofer (⇒ 27)

Remote control

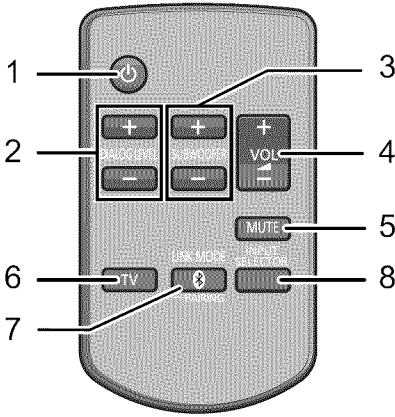

- 1 Turn the main unit on or off (⇒ 22)
- 2 Adjust the dialog effect level (⇒ 22)
- 3 Adjust the output level of the active subwoofer (bass sound) (⇒ 22)
- 4 Adjust the volume of this system (⇒ 22)
- 5 Mute the sound (⇒ 22)
- 6 Select the TV as the source (⇒ 22)
- 7 Select the Bluetooth® device as the source (⇒ 22)
- 8 Select the input source (⇒ 22)
 "TV" → "BD/DVD" → "AUX"
 ↑ "Bluetooth" ↓

■ Remote control operation range

The remote control signal sensor is located on the main unit.

- Use the remote control within the correct operation range.

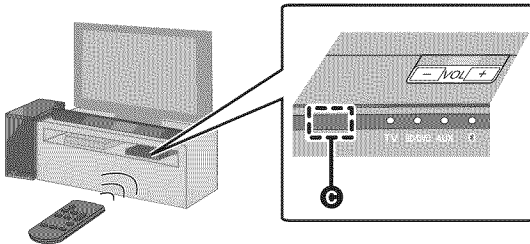

- Remote control signal sensor
- Operation range
 - Distance: Within approx. 7 m (23 ft) directly in front
 - Angle: Approx. 30° left and right

Remove the insulation sheet **A** before using.

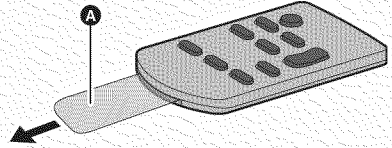

■ To replace a button-type battery

- ① While pressing the stopper **B**, pull out the battery holder.

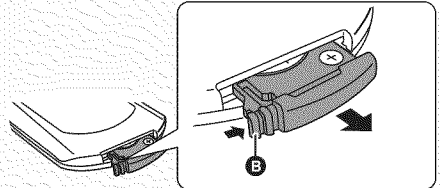

- ② Set the button-type battery with its (+) mark facing upward and then put the battery holder back in place.

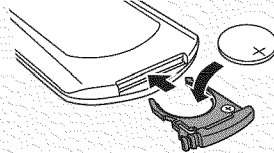

- When replacing the battery, use: CR2025 (Lithium battery)
- Keep the button-type battery out of reach of children to prevent swallowing.

Step 1 Selecting the placement method

- Choose a placement method that suits you best.

When attaching the speakers to a wall



Place the speakers horizontally

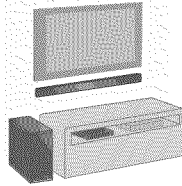

Page 10



Place the speakers vertically

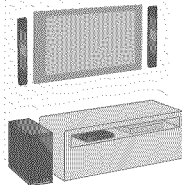

Page 12

When placing the speakers on a table



Place the speakers using the stands

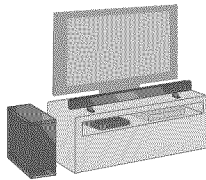

Page 14



Place the speakers using the support legs and speaker feet

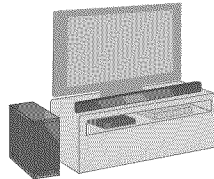

Page 15



Place the speakers using the speaker bases

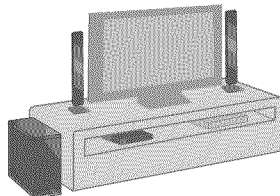

Page 16



Caution

- This system is to be used only as indicated in these instructions. Failure to do so may lead to damage to the amplifier and/or the speakers, and may result in the risk of fire. Consult a qualified service person if damage has occurred or if you experience a sudden change in performance.
- Do not attempt to attach these speakers to a wall using methods other than those described in this manual.

Speaker system

- Use a screwdriver (+) for assembling the speakers.
- Do not hold the speakers in one hand to avoid injury, you may drop the speakers when carrying them.

■ When attaching the speakers to a wall

The wall or pillar on which the speakers are to be attached should be capable of supporting 33 kg (72.8 lbs) per screw. Consultation with a qualified installation specialist is recommended when attaching the speakers to a wall. Improper attachment may result in damage to the wall and speakers, and personal injury.

■ When placing the speakers in front of the TV

The speakers may block or interfere with the TV's various sensors (C.A.T.S. (Contrast Automatic Tracking System) sensor, remote control sensor, etc.) and the 3D Eyewear transmitters on a 3D compatible TV.

• If the stands are being used

Move the speakers further away from the TV. If the TV still does not function properly, try removing the stands.

• If the stands are not used

Move the speakers further away from the TV. If the TV still does not function properly, try placing them beside the TV (⇒ 8).

Active subwoofer

When carrying the active subwoofer

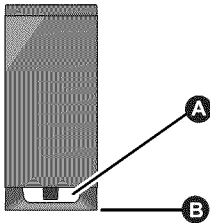

- A** Do not hold the active subwoofer from this opening. The parts inside (speaker unit) may be damaged.
- B** Always hold the bottom of the active subwoofer when moving it.

Wireless interference

To avoid interference, maintain the following distances between the main unit/active subwoofer and other electronic devices that use the same radio frequency (2.4 GHz and 5 GHz band).

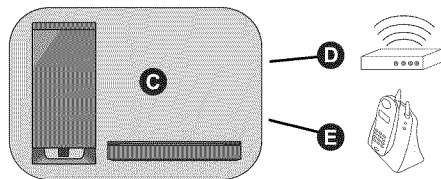

- C** Main unit/active subwoofer
- D** Wireless LAN: approx. 2 m (6 1/2 ft)
- E** Cordless phone and other electronic devices: approx. 2 m (6 1/2 ft)



- Place the active subwoofer within a few meters of the main unit and in a horizontal position with the top panel faced upward.
- Do not use the main unit or active subwoofer in a metal cabinet.
- Placing the active subwoofer and the speakers too close to the walls and corners can result in excessive bass. Cover walls and windows with thick curtains.
- If irregular coloring occurs on your TV, turn the TV off for about 30 minutes. If it persists, move the speakers further away from the TV.
- Keep magnetized items away. Magnetized cards, watches, etc., can be damaged if placed too close to the active subwoofer and the speakers.

Step 2 Assembling the speakers

When attaching the speakers to a wall

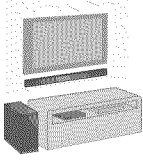

Place the speakers horizontally

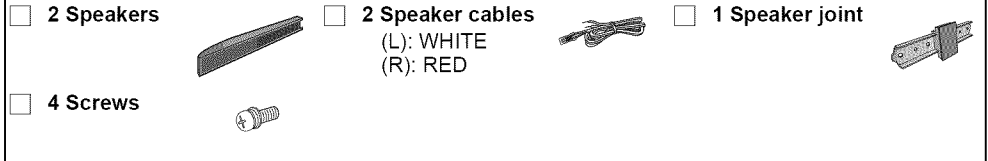

- For a safety measure to prevent the speakers from falling, refer to page 17.
- To prevent damage or scratches, lay down a soft cloth and perform the assembly on it.

1 Assemble the speakers.

- The two speakers are interchangeable.

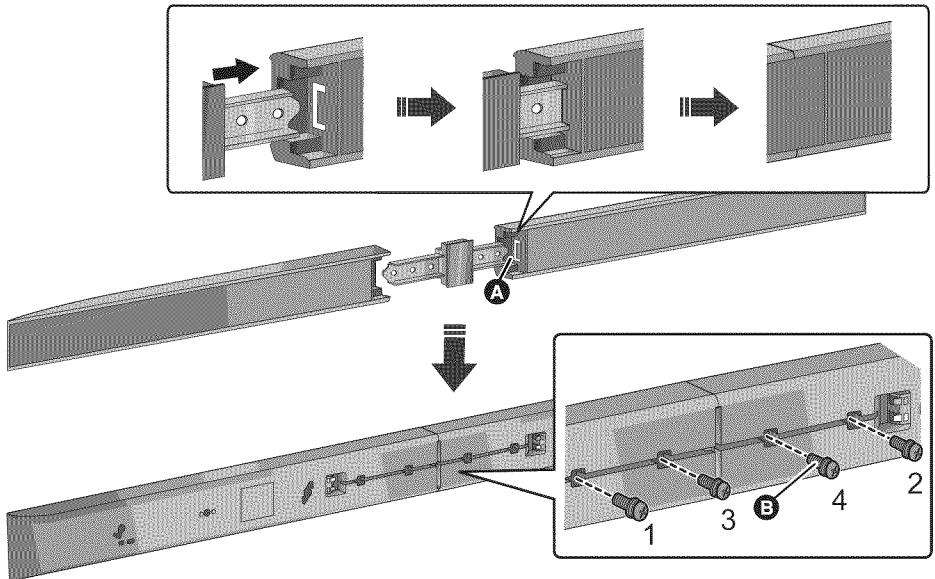

A "C" shaped slit

- Insert the speaker joint fully into the slit.

B Screw (supplied)

- Be sure to insert the screws following the order as indicated in the illustration.
- Keep the screws out of reach of children to prevent swallowing.

2 Connect the speaker cables.

- Use the "Panasonic" logo to identify the left and right speakers, then connect the cables (as illustrated).

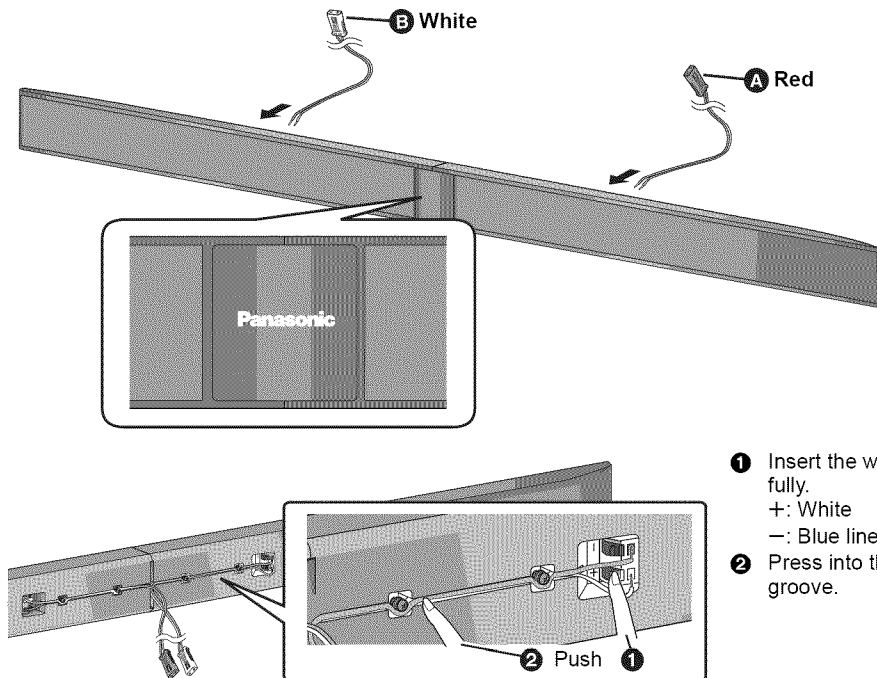

- Insert the wire fully.
+ : White
- : Blue line
- Press into the groove.

A RED: Right speaker channel (R)

B WHITE: Left speaker channel (L)

- Insert the wire fully, taking care not to insert beyond the wire insulation.

3 Drive a screw into the wall.

- Use the measurements indicated below to identify the screwing positions on the wall.
- Leave at least 20 mm ($25/32''$) of space above and on each side of the speaker to allow enough space for fitting the speaker.
- The position on the wall where the screw is to be attached, as well as the screw, should be capable of supporting over 33 kg (72.8 lbs).
- Keep the screws out of reach of children to prevent swallowing.

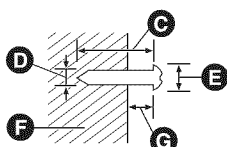

- C** At least 30 mm ($1 \frac{3}{16}''$)
- D** $\varnothing 4.0$ mm ($5/32''$)
- E** $\varnothing 7.0$ mm to $\varnothing 9.4$ mm ($9/32''$ to $3/8''$)
- F** Wall or pillar
- G** 5.5 mm to 6.5 mm ($7/32''$ to $1/4''$)

Front view (semi-transparent image)

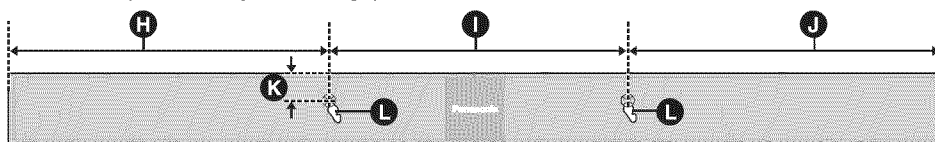

H 326 mm ($12 \frac{27}{32}''$)

I 316 mm ($12 \frac{7}{16}''$)

J 316 mm ($12 \frac{7}{16}''$)

K 26 mm ($1 \frac{1}{16}''$)

L Wall mounting hole

4 Fit the speaker securely onto the screw(s).

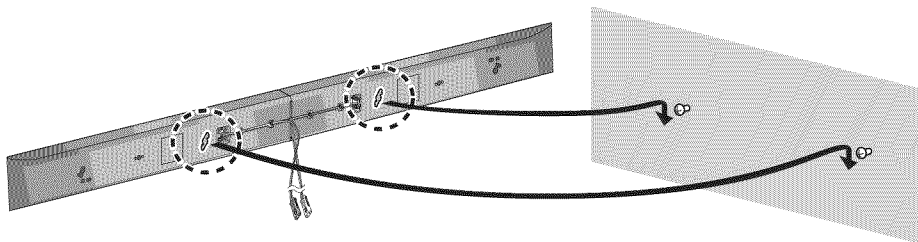

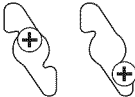
DO	DO NOT
 <ul style="list-style-type: none"> Move the speaker so that the screw is in this position. 	 <ul style="list-style-type: none"> In this position, the speaker will likely fall if moved to the left or right.

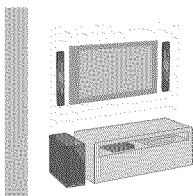

Place the speakers vertically

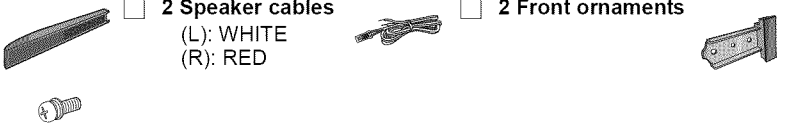
<input type="checkbox"/> 2 Speakers	<input type="checkbox"/> 2 Speaker cables (L): WHITE (R): RED	<input type="checkbox"/> 2 Front ornaments
<input type="checkbox"/> 4 Screws		

- For a safety measure to prevent the speakers from falling, refer to page 17.
- To prevent damage or scratches, lay down a soft cloth and perform the assembly on it.

1 Attach the front ornaments.

- The two speakers are interchangeable.
- Keep the screws out of reach of children to prevent swallowing.

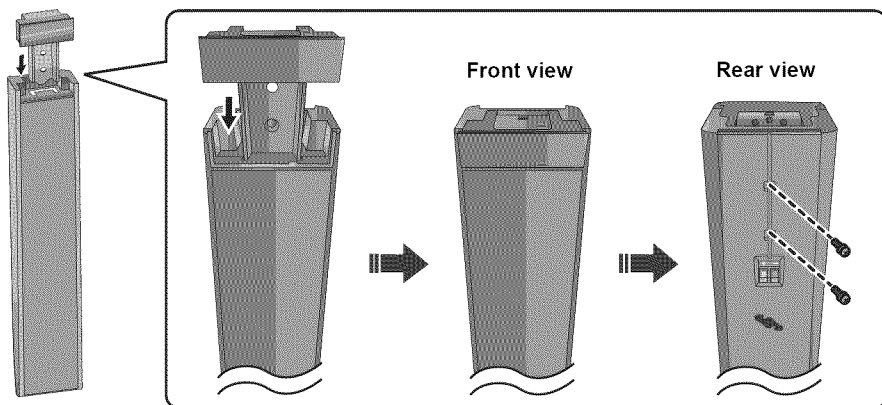

2 Connect the speaker cables.

- Insert the wire fully, taking care not to insert beyond the wire insulation.

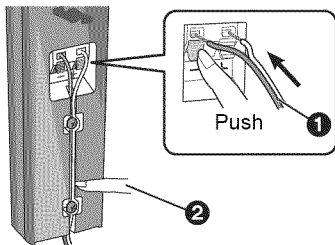

- 1 Insert the wire fully.
+ : White
- : Blue line
- 2 Press into the groove.

3 Drive a screw into the wall.

- Use the measurements indicated below to identify the screwing positions on the wall.
- Leave at least 20 mm ($\frac{2}{5}$ ") of space above and on each side of the speaker to allow enough space for fitting the speaker.
- The position in the wall where the screw is to be attached as well as the screw should be capable of supporting over 33 kg (72.8 lbs).
- Keep the screws out of reach of children to prevent swallowing.

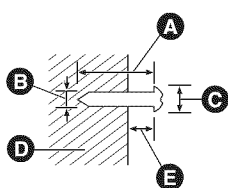

- A** At least 30 mm ($1 \frac{3}{16}$ ")
- B** $\varnothing 4.0$ mm ($\frac{5}{32}$ ")
- C** $\varnothing 7.0$ mm to $\varnothing 9.4$ mm ($\frac{9}{32}$ " to $\frac{3}{8}$ ")
- D** Wall or pillar
- E** 5.5 mm to 6.5 mm ($\frac{7}{32}$ " to $\frac{1}{4}$ ")

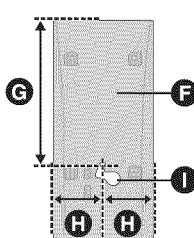

- F** Front speaker (Rear view)
- G** 102 mm ($4 \frac{1}{32}$ ")
- H** 37 mm ($1 \frac{15}{32}$ ")
- I** Wall mounting hole

4 Fit the speaker(s) securely onto the screw(s).

- Place the speaker that is connected with the speaker cable with a red connector on the observers' right, and connect with the speaker cable with a white connector on the observers' left.

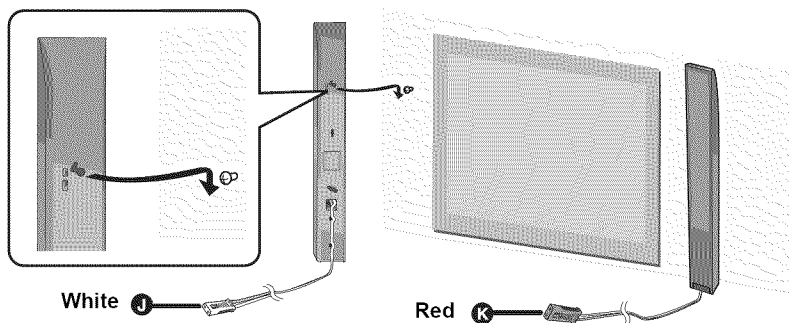

J WHITE: Left speaker channel (L)

K RED: Right speaker channel (R)

DO	DO NOT
<ul style="list-style-type: none"> • Move the speaker so that the screw is in this position. 	<ul style="list-style-type: none"> • In this position, the speaker will likely fall if moved to the left or right.

When placing the speakers on a table

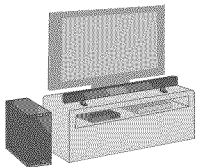

Place the speakers using the stands

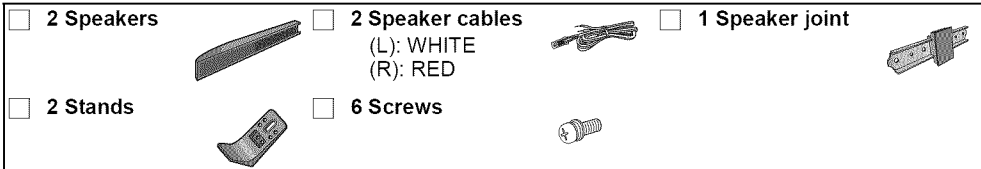

- For a safety measure to prevent the speakers from falling, refer to page 17.
- To prevent damage or scratches, lay down a soft cloth and perform the assembly on it.

1 Assemble the speakers following steps 1 and 2 of “Place the speakers horizontally” (⇒ 10).

2 Attach the stands.

- Use the “Panasonic” logo to identify the top and bottom of the speaker.
- Keep the screws out of reach of children to prevent swallowing.

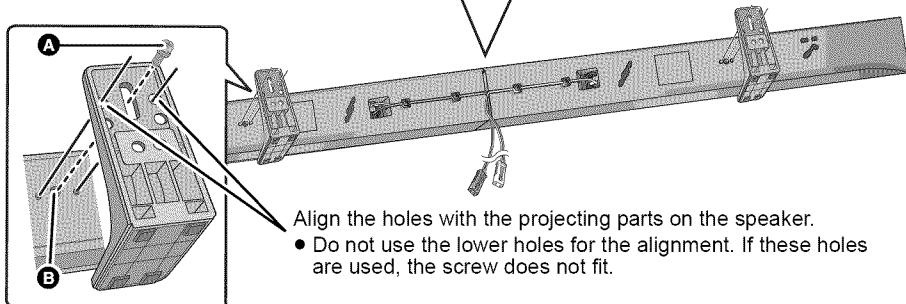
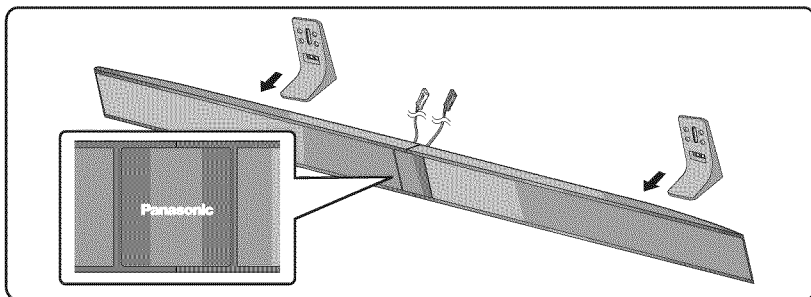

Align the holes with the projecting parts on the speaker.

- Do not use the lower holes for the alignment. If these holes are used, the screw does not fit.

- A** Screw (supplied)
- B** Screw hole

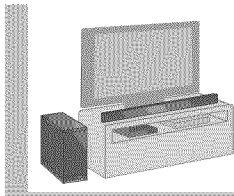

Place the speakers using the support legs and speaker feet

<input type="checkbox"/> 2 Speakers	<input type="checkbox"/> 2 Speaker cables (L): WHITE (R): RED	<input type="checkbox"/> 1 Speaker joint
<input type="checkbox"/> 6 Screws	<input type="checkbox"/> 2 Support legs	<input type="checkbox"/> 2 Speaker feet

- For a safety measure to prevent the speakers from falling, refer to page 17.
- To prevent damage or scratches, lay down a soft cloth and perform the assembly on it.

1 Assemble the speakers following steps 1 and 2 of “Place the speakers horizontally” (⇒ 10).

2 Attach the support legs and speaker feet.

- Use the “Panasonic” logo to identify the top and bottom of the speaker.
- Keep the screws and the speaker feet out of reach of children to prevent swallowing.

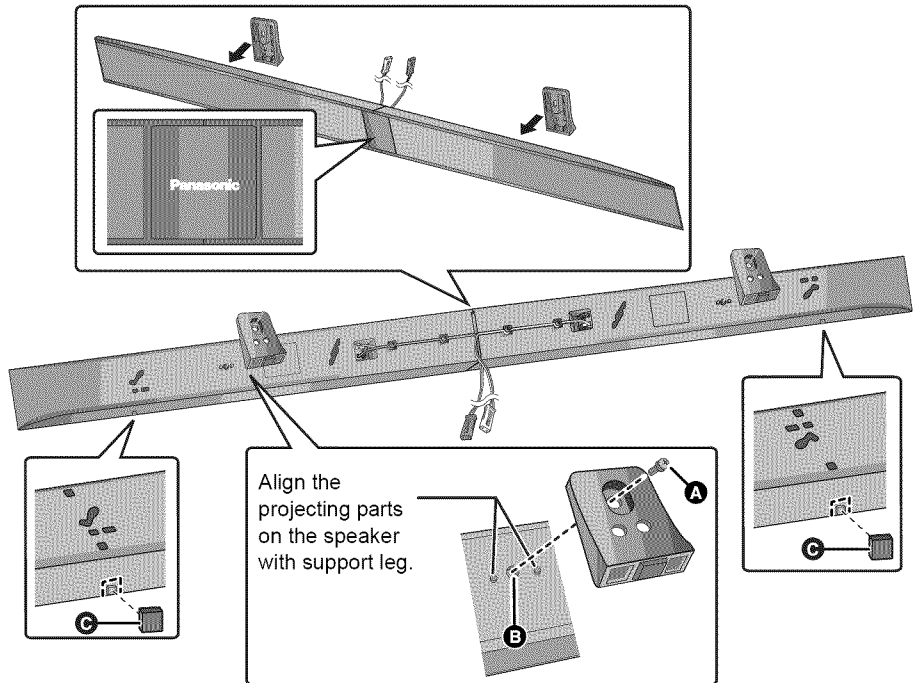

- A** Screw (supplied)
- B** Screw hole
- C** Speaker foot (supplied)
 - Attach the speaker foot directly below the wall mounting hole (as illustrated).

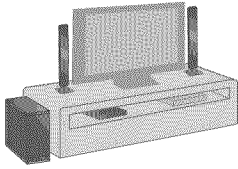

Place the speakers using the speaker bases

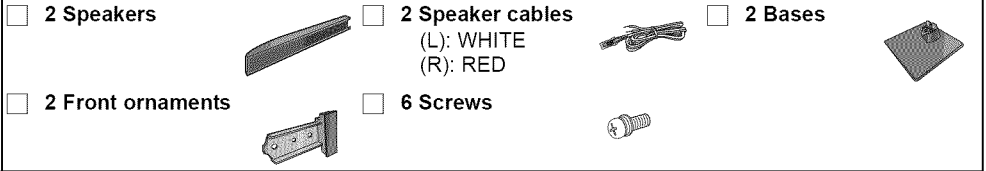

- For a safety measure to prevent the speakers from falling, refer to page 17.
- To prevent damage or scratches, lay down a soft cloth and perform the assembly on it.

1 Assemble the speakers following step 1 of “Place the speakers vertically” (⇒ 12).

2 Insert the speaker cable through the base.

- Be sure to insert the speaker cable through the threading hole as indicated in the illustration. (If the speaker cable is twisted, it might not fit through the opening. Straighten the speaker cable before inserting.)

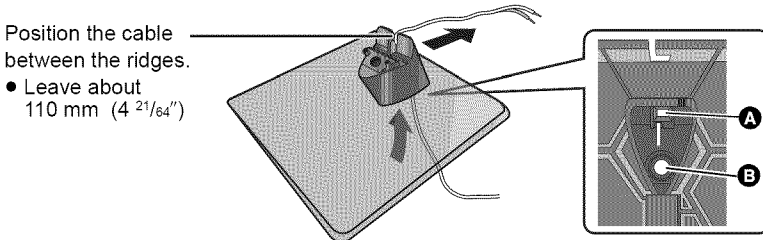

- A** Threading hole **B** Screw hole

3 Attach the speaker to the base.

- The two speakers are interchangeable.
- Keep the screws out of reach of children to prevent swallowing.

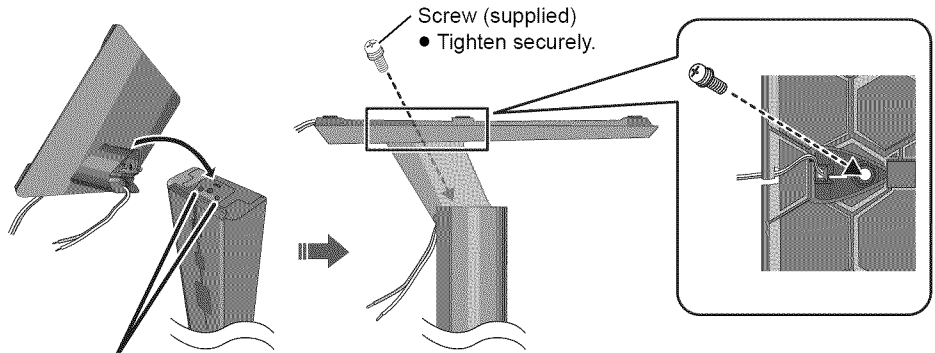

Align the projecting parts with the holes on the speaker.

4 Connect the speaker cables.

- Insert the wire fully, taking care not to insert beyond the wire insulation.

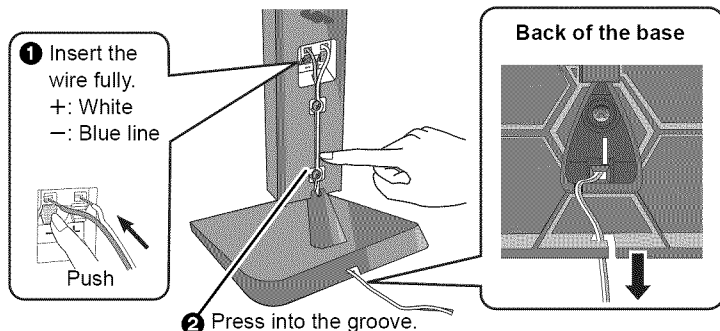

- Place the speaker that is connected with the speaker cable with a red connector on the observers' right, and connect with the speaker cable with a white connector on the observers' left.

Additional speaker fall prevention measures

To prevent the speakers from falling, it is recommended, as an additional protection measure, to attach the speakers to the wall or table with a fall prevention cord (hereafter "cord").



- Consultation with a qualified installation specialist concerning the appropriate procedure when attaching to a concrete wall or a surface that may not have strong enough support is recommended (⇒ 11, 13). Improper attachment may result in damage to the wall and speakers, and personal injury.
- Use a cord that is capable of supporting over 10 kg (22.05 lbs) (with a diameter of about 1.5 mm (1/16")).
- Keep the screws out of reach of children to prevent swallowing.
- Make sure that the slack of the cord is minimal.

When attaching the speakers to a wall

Horizontal placement

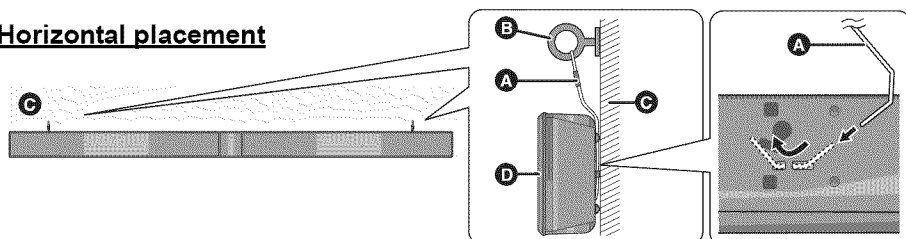

Vertical placement

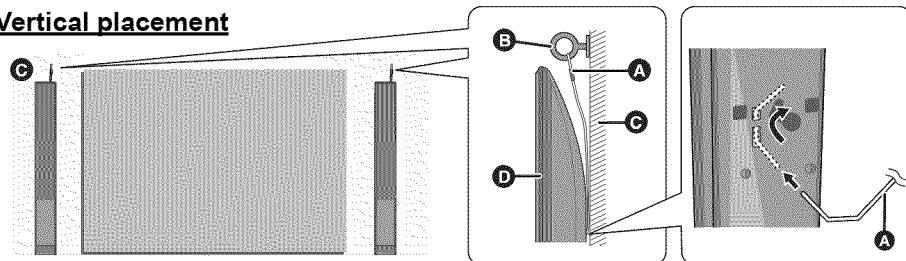

A Cord* **B** Screw eye **C** Wall **D** Wall-mounted speakers

※ If the cord cannot be threaded through the holes, try bending the cord in 2 locations, about 10 mm (13/32") apart from the tip, at an angle of 45° (as illustrated above).

When placing the speakers on a table

Horizontal placement

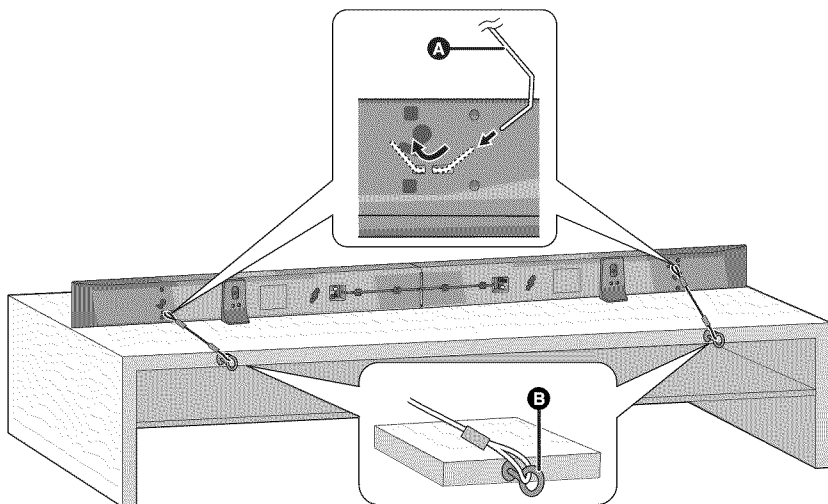

Vertical placement

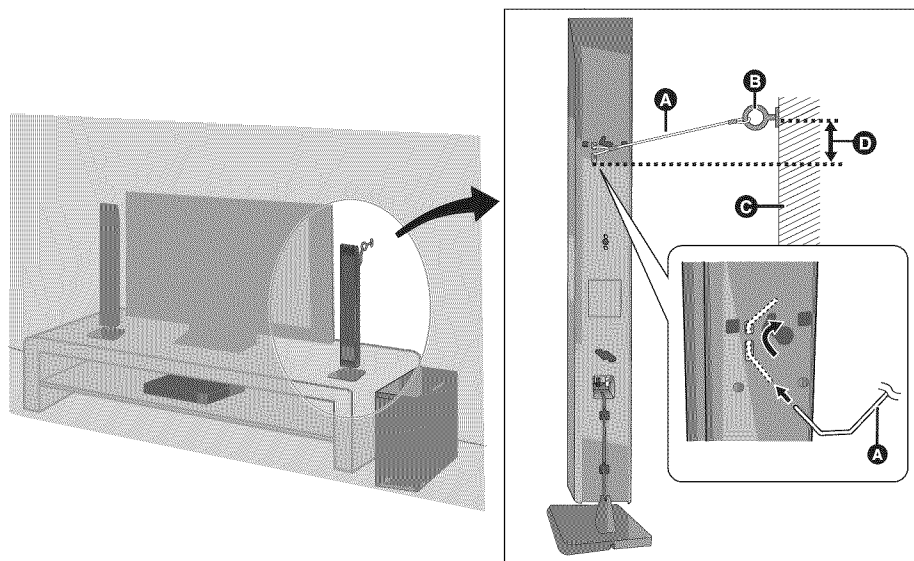

A Cord*

B Screw eye

- Depending on the placement of the speakers, the screwing position of the screw eye may differ.

C Wall

D Approx. 150 mm (5 ²⁹/₃₂")

※ If the cord cannot be threaded through the holes, try bending the cord in 2 locations, about 10 mm (¹³/₃₂") apart from the tip, at an angle of 45° (as illustrated above).

Step 3 Connections

- Turn off all equipment before connection and read the appropriate owner's manual.
Do not connect the AC power supply cord until all other connections are complete.

Connection with the TV

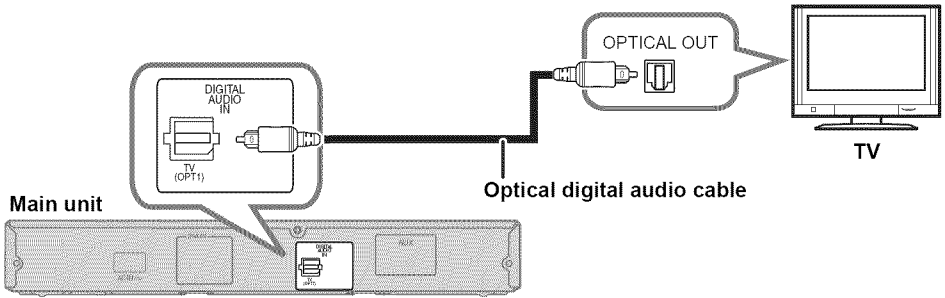

- When you use the optical digital audio cable, insert the tip correctly into the terminal.

Connection with other devices

You can direct the audio signal from the connected Blu-ray Disc player™, DVD player, Set Top Box, etc. to this system.

High quality audio

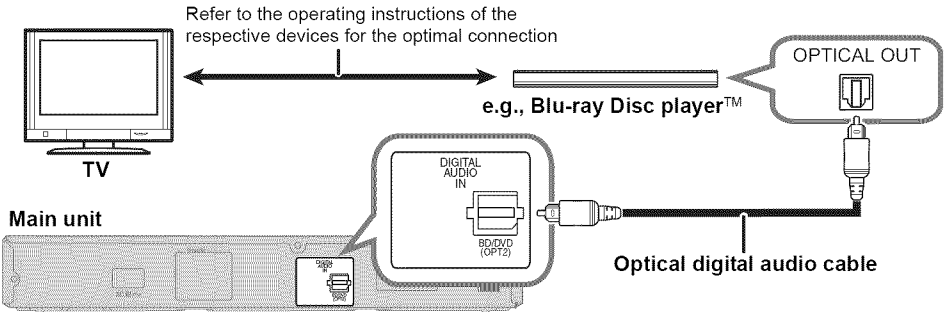

Standard quality audio

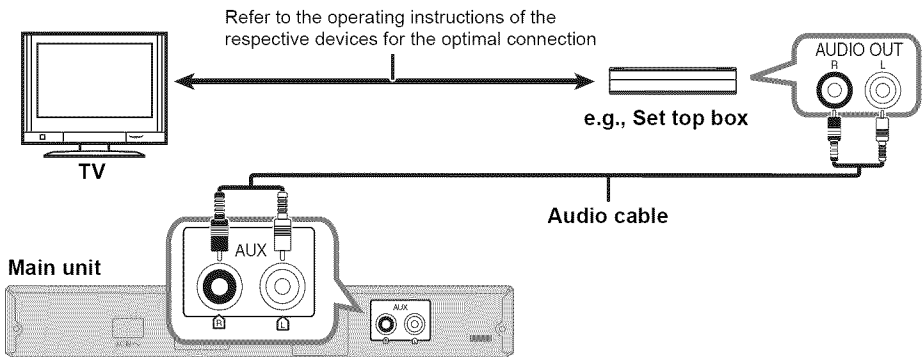

Speaker cable connection

Match the connector shape and connect to the terminals of the same color.

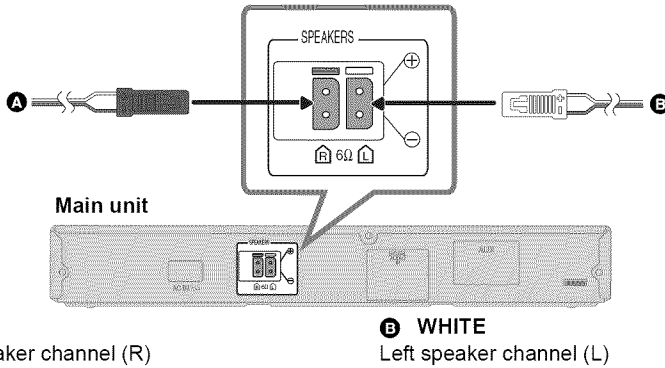

AC power supply cord connection

- Connect only after all other connections are complete.

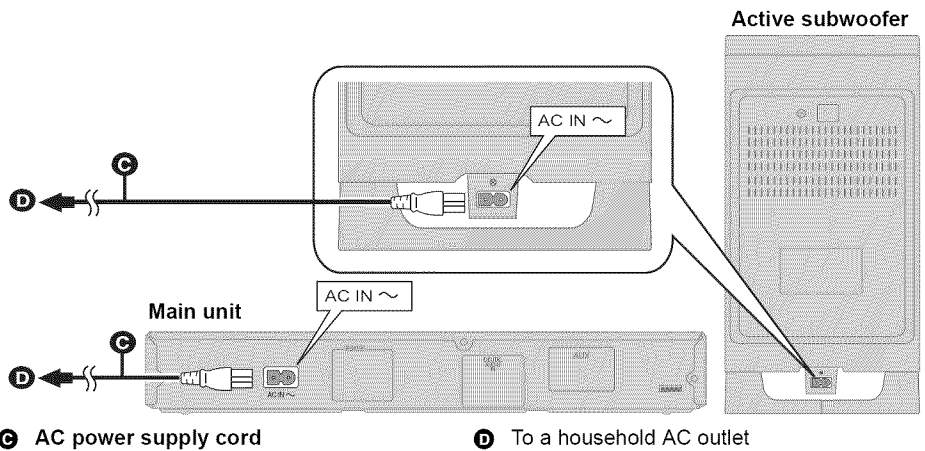

- The main unit and active subwoofer consume a small amount of AC power, even when it is turned off (this unit: approx. 0.1 W, active subwoofer: approx. 0.1 W). In the interest of power conservation, if you will not be using this system for a long time, unplug it from the household AC outlet.

Install this unit so that the power cord can be unplugged from the socket outlet immediately if any problem occurs.

Saving energy

The main unit is designed to conserve its power consumption and save energy.

- **The main unit will automatically switch to standby mode** when no signal is input and no operation is performed for approx. 30 minutes.

Active subwoofer wireless connection

Preparation

- Turn on the main unit.

- 1 Press [MUTE] [POWER] [MUTE].

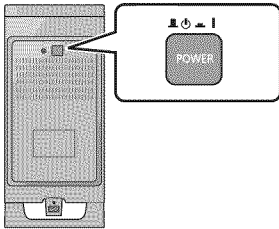

- 2 Check that the wireless link is activated.

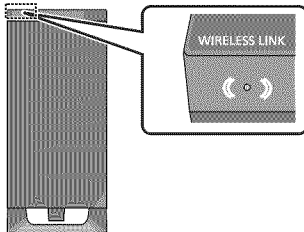

WIRELESS LINK indicator lights

- **Red:**
The wireless link is not activated.
- **Green:**
The wireless link is activated.

The unit will still consume a small amount of power even when it is turned off (MUTE, POWER)

Bluetooth® connection

With the Bluetooth® connection you can output the audio from the connected wireless device.

Preparation

- Turn on the Bluetooth® feature of the device and place the device near this unit.

Pairing a device

- 1 Press [BT] – PAIRING].
 - “BT” indicator will blink quickly.
- 2 Select “SC-HTB350/351” from the Bluetooth® device’s Bluetooth® menu.
 - Once the Bluetooth® device is connected, the “BT” indicator stops flashing and lights up.



Refer to the operating instructions of the Bluetooth® device for further instruction on how to connect a Bluetooth® device. If prompted for the passkey on the Bluetooth® device, enter “0000”.

Pairing additional devices

- 1 Press [BT] – PAIRING].
- 2 Press and hold the [BT] – PAIRING] until the “BT” indicator flashes quickly.
- 3 Repeat step 2 of “Pairing a device”.



- You can register up to 6 devices with this unit. If a 7th device is paired, the device that has not been used for the longest time will be replaced.
- This unit can only be connected to one device at a time.
- To change the sound quality, refer to “Bluetooth® communication mode” on page 24.

Using this unit

Preparation

- Turn on the TV and/or connected device.

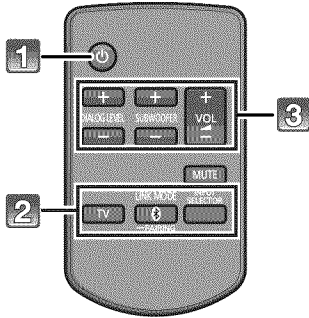

1 Press [⏻] to turn on the main unit.

2 Select the source.

Press	To select
[TV]	"TV"
[📶]	"📶" (Bluetooth®)
[INPUT SELECTOR]	"TV" → "BD/DVD" → "AUX" ↑ "📶" ↓

- This remote control cannot be used to control the operations of the connected devices.

■ When "📶" is selected as the source

On the Bluetooth® device:

Select this unit as the output source of the Bluetooth® device and start the playback.

- Make sure that the Bluetooth® device is already paired with this unit. (⇒ 21)
- Playback may pause when a different source is selected.

■ When "BD/DVD" is selected as the source

On the connected device:

Select the TV's input for this unit and start the playback on the connected device.

■ When "AUX" is selected as the source

On the connected device:

Select the TV's input for the device connected to "AUX" terminal and start the playback on the connected device.



If the main unit does not operate as expected or sound is unusual, return the settings to the factory preset and operate the system again. (⇒ 26)

※ The audio format indicators blink from left to right (+) or from right to left (–) while adjusting.

- The indicators will not blink when it has reached the maximum or minimum.
- If there is sound coming out of the TV's speakers, reduce the volume of the TV to its minimum.
- If the main unit is turned off with the volume setting in the greater half (above 50), the main unit will automatically lower the volume to the middle (50) when the main unit is turned on (Volume limitation). To turn this function off, refer to page 25.

3 Adjust the volume and sound effect level.

■ To adjust the volume of the system

Press [+ VOL –].

- Volume range: 1 to 100*

■ To adjust the dialog effect level

This setting will change the level of the Clear-mode dialog effect. (⇒ 23)

- 1 Press [+ DIALOG LEVEL –] to display the current level.
- 2 While the level is displayed:
Press [+ DIALOG LEVEL –] to adjust the level.*

Indication		Effect level
	4	Highest
	3	
	2	
	1	Lowest

■ To adjust the subwoofer level

- 1 Press [+ SUBWOOFER –] to display the current level.

2 While the level is displayed:

- 1 Press [+ SUBWOOFER –] to adjust the level.*

- The level indication pattern is the same as dialog effect level.

■ To mute the sound

Press [MUTE].

- While muting, the audio format indicators blink simultaneously.
- To cancel, press the button again or adjust the volume.
- Muting is canceled if the main unit is turned off.

3D sound

This system provides a feeling that the sound and the image are as one. The 3D sound effect will be applied to Multi-channel audio sources as a factory preset.

e.g., Image of 3D sound field

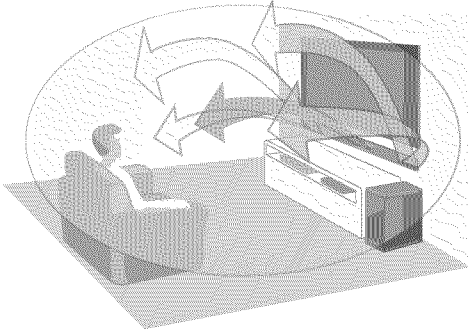

3D sound	
Dolby Virtual Speaker	With this effect you can enjoy a surround sound effect similar to 5.1ch.
3D surround effect	Adding to the Dolby Virtual Speaker effect, Panasonic has applied its own sound field controlling technology to expand the sound field forwards, backwards, upwards, and downwards, providing a sound with depth and force that better matches 3D images.
Clear-mode dialog	Sports commentary and dialogs from TV dramas are heard as if the sound is coming from the TV, giving the feeling that the sound and the image are one. Also, the dialog will stand out from the other sounds during normal volume playback and when the volume is lowered for night time viewing.



Dolby Virtual Speaker and the 3D surround effects can be turned off and on by changing the audio output mode settings.

Audio output modes

As a factory preset, Dolby Virtual Speaker and the 3D surround effects will be applied to Multi-channel audio sources, such as those from a Blu-ray Disc player™ or DVD player, etc.

By changing the audio output setting, it is possible to apply the Dolby Virtual Speaker and 3D surround effects to 2ch audio sources, such as the audio from the TV.

To change the audio output mode

1 Press and hold [MUTE] for more than 2 sec.

- The indicator for the current setting blinks for 10 sec.

2 While the indicator is blinking, press [MUTE] again to change the setting.

- The setting changes each time [MUTE] is pressed.

Audio output mode	Dolby Virtual Speaker and 3D surround effect
Multi-channel mode 	The effects are applied to all audio sources.
Auto mode (Direct mode)^{※1} (Factory preset) 	The effects are applied to Multi-channel audio sources. The effects are not applied to 2 channel audio sources.
2ch mode 	The effects are not applied to any audio source.

※1 Depending on the audio source, Dolby Virtual Speaker and 3D surround effect settings are automatically adjusted.

※2 This indicator will also light when the audio source is Multi-channel audio.



When using the optical digital audio cable, Dolby Virtual Speaker and the 3D surround effect will be temporarily canceled if the audio signal's sampling frequency is greater than 48 kHz.

Advanced operations

Changing the dual audio

Change the dual audio from main to secondary.

- 1 Confirm the digital audio output setting on the connected TV or player, etc. is set to “Bitstream”.**
- 2 Press and hold [TV] for more than 2 sec.**
- 3 While the indicator of the current setting is blinking, press [TV] to change the setting.**

- The indicator for the current setting blinks for 10 sec.



A : Main



B : Secondary
(SAP: Secondary Audio Program)

A, **B** : Main and secondary

- The setting works only when the dual audio is available in the audio source.
- The setting is maintained until it is changed again.
- The same setting is used for all digital audio sources.

Auto gain control

With this function, you can prevent sudden loud sounds. The output will be reduced automatically when the input exceeds a certain level.

- 1 Press and hold [INPUT SELECTOR] on remote controller for more than 2 sec.**

- The indicator for the current setting blinks for 10 sec.



Dolby Digital indicator blinks:
Auto gain control is on.



PCM indicator blinks:
Auto gain control is off.

- 2 While the indicator is blinking, press [INPUT SELECTOR] to change the setting.**

- The setting changes each time [INPUT SELECTOR] is pressed.
- The setting is maintained until it is changed again.
- Default setting of this function is OFF.

Bluetooth® communication mode

You can select different modes to suit the type of connections which emphasis on connectivity or high quality audio.

- Make sure that a Bluetooth® device is already paired with this unit. (⇒ 21)

- 1 Disable the Bluetooth® connection of the device.**

- “” indicator will blink slowly.

- 2 Press [LINK MODE, ] to display the current mode.**

- The indicator for the current setting blinks for 10 sec.



MODE1: (Factory preset)
Emphasis on connectivity



MODE2:
Emphasis on audio quality

- 3 While the mode is displayed, press [LINK MODE, ] to select the mode.**

- The setting changes each time [LINK MODE, ] is pressed.
- The setting is maintained until it is changed again.

To turn off the 3D surround effect and clear-mode dialog effect

Depending on your preference, It is possible to use only the Dolby Virtual Speaker effect by turning off the 3D surround effect and the clear-mode dialog effect.

- 1 Press and hold [TV] on the remote control and followed by [VOL +] on the main unit for more than 2 sec.**

- The indicator for the current setting blinks for 10 sec.



Dolby Digital indicator blinks:
3D surround effect and clear-mode dialog effect is on.



PCM indicator blinks:
3D surround effect and clear-mode dialog effect is off.

- 2 While the indicator is blinking, press [TV] to change the setting.**

- The setting changes each time [TV] is pressed.
- This setting will be reset to on when this system is turned off.
- When off is selected, the dialog effect level cannot be adjusted.

Others

The following settings are unnecessary under general usage conditions of the system.

Remote control code

When other Panasonic devices respond to this system's remote control, change the remote control code on the main unit and the remote control.

Preparation

- Turn off all other Panasonic products.
- Turn on the main unit.

Change the remote control code to code 2:

- 1 Aim the remote control at this system's remote control sensor.
 - 2 Press and hold [MUTE] and [
- All the indicators will blink for 10 sec when the code of this system is changed.

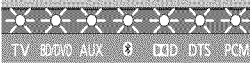

- The setting is maintained until it is changed again.



- If this system does not operate after changing the code, repeat steps 1 and 2.
- To change the remote control code to code 1, repeat the steps above, but replace [

To reduce the clear-mode dialog effect

When the dialog does not sound natural while the volume is set low, for example, it is possible to reduce the dialog enhancing effect as follows:

Press and hold [TV] on the remote control and followed by [- VOL] on the main unit for more than 2 sec.

- All the indicators will blink once when the clear-mode dialog effect is reduced.



- Even if clear-mode dialog effect is reduced, dialog effect level is still adjustable.

To turn off the volume limitation

If a state of the lowered volume disturbs you every time this system turns on, for example, it is possible to turn off this function as follows:

Press and hold [MUTE] on the remote control and followed by [VOL +] on the main unit for more than 2 sec.

- All the indicators will blink once when the volume limitation is turned off.



The settings of the clear-mode dialog effect and the volume limitation remain intact even if you switch this system to standby mode. To turn these 2 functions back on, this system must be set back to the factory preset. (⇒ 26)

Troubleshooting

Before requesting service, make the following checks. If you are in doubt about some of the check points, or if the solutions indicated in the following guide do not solve the problem, refer to "Customer Services Directory (United States and Puerto Rico)" on page 31.

To return to the factory preset.

While the main unit is on, press [P/I] on the main unit for more than 4 sec.

(All the indicators will blink twice when the main unit is reset.)

If the system does not operate as expected, returning the settings to the factory preset may solve the problem.

- The remote control code will return to "1" when the main unit is returned to the factory preset. To change the remote control code, refer to page 25.

General operation

No power.

- Insert the AC power supply cord securely. (⇒ 20)
- After turning the main unit on, if the indicators blink and the main unit immediately turns off, unplug the AC power supply cord and consult your dealer.

The remote control does not work properly.

- The battery is depleted. Replace it with a new one. (⇒ 7)
- It is possible that the insulation sheet has not been removed. Remove the insulation sheet. (⇒ 7)
- It may be necessary to set the code of the remote control again after changing the battery of the remote control. (⇒ 25)
- Use the remote control within the correct operation range. (⇒ 7)

The "TV" indicator blinks.

Remove the AC power supply cord and consult your dealer. If there are any other indicators blinking, be sure to inform your dealer about the blinking indicators.

The main unit is automatically switched to standby mode.

The main unit will automatically switch to standby mode when no signal is input and no operation is performed for approx. 30 minutes. (⇒ 20)

Bluetooth®

Pairing cannot be done.

Check the Bluetooth® device condition.

The device cannot be connected.

- The pairing of the device was unsuccessful. Try pairing the device again.
- The pairing of the device has been replaced. Pair the device again. (⇒ 21)
- The system might be connected to a different device. Disconnect the other device and try pairing the device again.

The device is connected but audio cannot be heard through the system.

For some built-in Bluetooth® devices, you have to set the audio output to "SC-HTB350/351" manually. Read the operating instructions for the device for details.

Sound from the device is uneven.

- The device is out of the 10 m (33 ft) communication range. Bring the device closer to the main unit.
- Remove any obstacle between the main unit and the device.
- Switch off any wireless LAN device.
- Select "MODE 1" for stable communication. (⇒ 24)

Sound

No sound (or image).

- Turn muting off. (⇒ 22)
- Check the connections to the other devices. (⇒ 19)
- Make sure that the received audio signal is compatible with this system. (⇒ 29)
- Turn this system off and then on again.
- If the connections are correct, there might be a problem with the cables. Redo the connections with different cables.
- Check the audio output settings on the connected device.

The dual audio cannot be changed from main to secondary.

If the audio received from the connected device is not "Dolby Dual Mono" or the output setting is not "Bitstream", the setting cannot be changed from this system. Change the setting on the connected device.

The volume is lowered when this system is turned on.

If the main unit is turned off with the volume setting in the greater half (above 50), the main unit will automatically lower the volume to the middle (50) when the main unit is turned on. (⇒ 25)

About Bluetooth®

The dialog is too persistent or the dialog does not sound natural.

This system has a function to make the dialog stand out when the volume is low. (⇒ 25)

There is no audio.

The power of the main unit turns off automatically.

(When the main unit detects a problem, a safety measure is activated and the main unit automatically switches to standby mode.)

- There is a problem with the amplifier.
- Is the volume extremely high?
If so, lower the volume.
- Is this system placed in an extremely hot place?
If so, move this system to a cooler place and wait a few moments and then try to turn it on again.

If the problem persists, confirm the TV indicator and AUX indicator blink, turn the system off, remove the AC power supply cord and consult your dealer. Please be sure to remember the indicators that were blinking and inform the dealer.

Active Subwoofer

No power.

Ensure the AC power supply cord of the active subwoofer is connected properly.

After turning the subwoofer on, it immediately turns off.

Unplug the AC power supply cord and consult your dealer.

No sound from the subwoofer.

- Check that the active subwoofer is turned on.
- Check that the wireless link indicator lights green. (⇒ 21)

The wireless link indicator lights red.

- There is no link between this unit and the active subwoofer.
 - Check that this unit is turned on.
 - Turn the active subwoofer off and then back on. Alternatively, turn the active subwoofer off, disconnect the AC power supply cord and then reconnect it.
- The active subwoofer and the main unit may not be paired correctly. Try the following operation. (Wireless pairing)
 - ① Turn on the main unit and active subwoofer.
 - ② Press [ID SET] on the rear of the active subwoofer. (The WIRELESS LINK indicator will light red and green alternately.)
 - ③ Press and hold [INPUT SELECTOR] on remote control and followed by [VOL +] on the main unit for more than 2 sec. (The BD/DVD indicator will blink and audio format indicators light up in sequence.)
 - When the wireless pairing is successful, BD/DVD indicator will stop flashing and WIRELESS LINK indicator lights green.
 - ④ Turn the main unit off and on.
- Consult your dealer if the problem persists.

Panasonic bears no responsibility for data and/or information that is compromised during a wireless transmission.

■ Frequency band used

This unit uses the 2.4 GHz frequency band.

■ Certification of this device

- This system conforms to frequency restrictions and has received certification based on frequency laws. Thus, a wireless permit is not necessary.
- The action below are punishable by law in some countries:
 - Taking apart or modifying the unit.
 - Removing specification indications.

■ Restrictions of use

- Wireless transmission and/or usage with all Bluetooth® equipped devices is not guaranteed.
- All devices must conform to standards set by Bluetooth SIG, Inc.
- Depending on the specifications and settings of a device, it can fail to connect or some operations can be different.
- This system supports Bluetooth® security features. But depending on the operating environment and/or settings, this security is possibly not sufficient. Transmit data wirelessly to this system with caution.
- This system cannot transmit data to a Bluetooth® device.

■ Range of use

Use this device at a maximum range of 10 m (33 ft). The range can decrease depending on the environment, obstacles or interference.

■ Interference from other devices







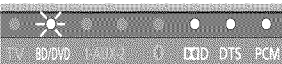

- When other devices use the same frequency as this system, this system may operate incorrectly or the sound may be distorted.
- To prevent interference from other devices:
 - Keep the system away from other devices that emit radio frequency interference.
 - Do not use this system and a wireless LAN device at the same time. Switch off any wireless LAN device.

■ Intended usage

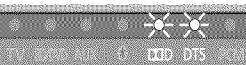
- This unit is for normal, general use only.
- Do not use this system near an equipment or in an environment that is sensitive to radio frequency interference (example: airports, hospitals, laboratories, etc).

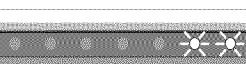
Indicator illumination

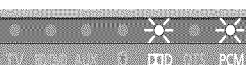
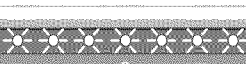
The indicators display the condition of this system by flashing. The indicator patterns illustrated below are displayed during normal operational conditions. They do not refer to the indications of a problem. Refer to "Troubleshooting" (⇒ 26) if the indicators do not light up as illustrated below.

Indicator	Description
	<p>The indicators blink simultaneously.</p> <ul style="list-style-type: none"> When "MUTE" is on (⇒ 25)
	<p>The BD/DVD indicator blinks^{※2} and audio format indicators light up in sequence for 1 minute.</p> <ul style="list-style-type: none"> When the main unit is in wireless pairing mode with the active subwoofer (⇒ 27)
	<p>The indicator blinks for 10 sec.</p> <ul style="list-style-type: none"> When the audio output mode is Multi-channel mode (⇒ 23) When 3D surround effect and clear-mode dialog effect are on (⇒ 24) When the dual audio setting is Main (⇒ 24) When the auto gain control is on (⇒ 24) When the Bluetooth® communication is mode 1 (⇒ 24) When the dialog effect level or the subwoofer level is 1 (⇒ 22)
	<p>The indicators blink for 10 sec.</p> <ul style="list-style-type: none"> When the audio output mode is Auto mode (⇒ 23) When the dialog effect level or the subwoofer level is 2 (⇒ 22)
	<p>The indicator blinks for 10 sec.</p> <ul style="list-style-type: none"> When the audio output mode is Auto mode (⇒ 23)
	<p>The indicators blink for 10 sec.</p> <ul style="list-style-type: none"> When the dialog effect level or the subwoofer level is 3 (⇒ 22)
	<p>The indicator blinks for 10 sec.</p> <ul style="list-style-type: none"> When the audio output mode is 2ch mode (⇒ 23) When 3D surround effect and clear-mode dialog effect are off (⇒ 24) When the dual audio setting is Secondary (SAP: Secondary Audio Program) (⇒ 24) When the auto gain control is off (⇒ 24) When the Bluetooth® communication is mode 2 (⇒ 24) When the dialog effect level or the subwoofer level is 4 (⇒ 22)
	<p>The indicators blink for 10 sec.</p> <ul style="list-style-type: none"> When the dual audio setting is Main and Secondary (⇒ 24)
	<p>The indicators blink for 10 sec.</p> <ul style="list-style-type: none"> When the remote control code is changed (⇒ 25)
	<p>The indicators blink once.</p> <ul style="list-style-type: none"> When changing the setting ("To reduce the clear-mode dialog effect" and "To turn off the volume limitation") (⇒ 25)
	<p>Bluetooth® indicator blinks quickly.</p> <ul style="list-style-type: none"> When the main unit is ready for pairing <p>Bluetooth® indicator blinks slowly.</p> <ul style="list-style-type: none"> When the main unit is waiting to connect <p>Bluetooth® indicator turns on.</p> <ul style="list-style-type: none"> When the main unit is connected with a Bluetooth® device

※1 The selected source indicator will also light.

※2 The BD/DVD indicator stops blinking and lights once the wireless pairing is successful.

Specifications

AMPLIFIER SECTION

RMS output power

10 % total harmonic distortion

Subwoofer ch

120 W per channel (100 Hz, 8 Ω)

Front ch (L, R ch)

60 W per channel (1 kHz, 6 Ω)

Total RMS Dolby Digital mode power

240 W

FTC output power

1.0 % total harmonic distortion

Subwoofer ch

60 Hz to 120 Hz 40 W (8 Ω)

Front ch (L, R ch)

120 Hz to 20 kHz 25 W (6 Ω)

Total FTC Dolby Digital mode power

90 W

WIRELESS SECTION

Wireless module

Frequency Range 5.150 GHz to 5.250 GHz

5.725 GHz to 5.850 GHz

Number of channels

9

TERMINAL SECTION

Digital audio input

Optical digital input (TV, BD/DVD)

2

Sampling frequency

32 kHz, 44.1 kHz, 48 kHz

88.2 kHz, 96 kHz (only LPCM)

Audio format

LPCM, Dolby Digital, DTS

SPEAKER SECTION

Front speakers

2 way, 2 speaker system (Bass reflex type)

Speaker unit(s)

Impedance 6 Ω

Woofer

6.5 cm (2 1/2") cone type × 1

Tweeter

2.5 cm (1") semi-dome type × 1

Frequency range 100 Hz to 30 kHz (−16 dB)

150 Hz to 25 kHz (−10 dB)

Active subwoofer

1 way, 1 speaker system (Bass reflex type)

Woofer

16 cm (6 1/2") cone type × 1

Frequency range 30 Hz to 180 Hz (−16 dB)

35 Hz to 160 Hz (−10 dB)

GENERAL

Power consumption

Main unit: 25 W

Active subwoofer: 21 W

In standby condition

Main unit: Approx. 0.1 W

Active subwoofer: Approx. 0.1 W

Power supply

AC 120 V, 60 Hz

Dimensions (W×H×D)

Main unit

Cabinet dimension

310 mm × 44 mm × 195 mm

(12 7/32" × 1 23/32" × 7 11/16")

Maximum outer dimension

310 mm × 45 mm × 202 mm

(12 7/32" × 1 25/32" × 7 15/16")

Active subwoofer

180 mm × 408 mm × 306 mm

(7 3/32" × 16 1/16" × 12 1/16")

Mass (Weight)

Main unit

1.1 kg (2.4 lbs)

Active subwoofer

5.2 kg (11.47 lbs)

Operating temperature range

0 °C to +40 °C (+32 °F to +104 °F)

Operating humidity range

20 % to 80 % RH (no condensation)

SPEAKER GENERAL

Horizontal placement using the stands

Dimensions (W×H×D)

956 mm×102 mm×74 mm
(37 5/8"×4 1/32"×2 29/32")

Mass (Weight) 1.61 kg (3.7 lbs)

Horizontal placement using the speaker feet and the support legs

Dimensions (W×H×D)

956 mm×78 mm×55 mm
(37 5/8"×3 1/16"×2 5/32")

Mass (Weight) 1.57 kg (3.5 lbs)

Horizontal placement (for wall mount)

Dimensions (W×H×D)

956 mm×75 mm×35 mm
(37 5/8"×2 15/16"×1 3/8")

Mass (Weight) 1.54 kg (3.5 lbs)

Vertical placement using the speaker bases

Dimensions (W×H×D)

148 mm×528 mm×145 mm
(5 13/16"×20 25/32"×5 23/32")

Mass (Weight) 0.88 kg (1.98 lbs)

Vertical placement (for wall mount)

Dimensions (W×H×D)

75 mm×478 mm×35 mm
(2 15/16"×18 13/16"×1 3/8")

Mass (Weight) 0.77 kg (1.76 lbs)

Bluetooth® SECTION

Bluetooth® system specification

V2.1 + EDR

Wireless equipment classification

Class 2 (2.5 mW)

Supported profiles

A2DP, AVRCP

Frequency band

2402 MHz to 2480 MHz
(Adaptive Frequency Hopping)

Operating distance

10 m (33 ft) Line of Sight



- 1 Specifications are subject to change without notice.
- 2 Weight and dimensions are approximate.
- 3 Total harmonic distortion is measured by a digital spectrum analyzer.

Limited Warranty (ONLY FOR U.S.A. AND PUERTO RICO)

Panasonic Consumer Marketing Company of North America,
Division of Panasonic Corporation of North America
One Panasonic Way, Secaucus, New Jersey 07094

Panasonic Home Audio Products Limited Warranty

Limited Warranty Coverage (For USA and Puerto Rico Only)

If your product does not work properly because of a defect in materials or workmanship, Panasonic Consumer Marketing Company of North America (referred to as "the warrantor") will, for the length of the period indicated on the chart below, which starts with the date of original purchase ("warranty period"), at its option either (a) repair your product with new or refurbished parts, (b) replace it with a new or a refurbished equivalent value product, or (c) refund your purchase price. The decision to repair, replace or refund will be made by the warrantor.

Product or Part Name	Parts	Labor
Audio Products (except items below)	1 year	1 year
DVD Home Theater System	1 year	1 year
Home Theater Audio System	1 year	1 year
SD Memory Cards, Rechargeable Battery Packs (defective exchange)	90 days	Not Applicable

During the "Labor" warranty period there will be no charge for labor. During the "Parts" warranty period, there will be no charge for parts. This Limited Warranty excludes both parts and labor for non-rechargeable batteries, antennas, and cosmetic parts (cabinet). This warranty only applies to products purchased and serviced in the United States or Puerto Rico. This warranty is extended only to the original purchaser of a new product which was not sold "as is".

Carry-In or Mail-In Service

To find a service center please visit <http://www.panasonic.com/help> or call 1-800-211-PANA (7262).

When shipping the unit, carefully pack, include all supplied accessories listed in the Owner's Manual, and send it prepaid, adequately insured and packed well in a carton box. When shipping Lithium Ion batteries please visit our Web Site at www.panasonic.com/BatteryHandling as Panasonic is committed to providing the most up to date information. Include a letter detailing the complaint, a return address and provide a daytime phone number where you can be reached. A valid registered receipt is required under the Limited Warranty.

IF REPAIR IS NEEDED DURING THE WARRANTY PERIOD, THE PURCHASER WILL BE REQUIRED TO FURNISH A SALES RECEIPT, PROOF OF PURCHASE INDICATING DATE OF PURCHASE, AMOUNT PAID AND PLACE OF PURCHASE. CUSTOMER WILL BE CHARGED FOR THE REPAIR OF ANY UNIT RECEIVED WITHOUT SUCH PROOF OF PURCHASE.

Limited Warranty Limits And Exclusions

This warranty ONLY COVERS failures due to defects in materials or workmanship, and DOES NOT COVER normal wear and tear or cosmetic damage. The warranty ALSO DOES NOT COVER damages which occurred in shipment, or failures which are caused by products not supplied by the warrantor, or failures which result from accidents, misuse, abuse, neglect, mishandling, misapplication, alteration, faulty installation, set-up adjustments, misadjustment of consumer controls, improper maintenance, power line surge, lightning damage, modification, introduction of sand, humidity or liquids, commercial use such as hotel, office, restaurant,

or other business or rental use of the product, or service by anyone other than a Factory Service Center or other Authorized Servicer, or damage that is attributable to acts of God.

THERE ARE NO EXPRESS WARRANTIES EXCEPT AS LISTED UNDER "LIMITED WARRANTY COVERAGE". THE WARRANTOR IS NOT LIABLE FOR INCIDENTAL OR CONSEQUENTIAL DAMAGES RESULTING FROM THE USE OF THIS PRODUCT, OR ARISING OUT OF ANY BREACH OF THIS WARRANTY.

(As examples, this excludes damages for lost time, travel to and from the servicer, loss of or damage to media or images, data or other memory or recorded content. The items listed are not exclusive, but for illustration only.) **ALL EXPRESS AND IMPLIED WARRANTIES, INCLUDING THE WARRANTY OF MERCHANTABILITY, ARE LIMITED TO THE PERIOD OF THE LIMITED WARRANTY.**

Some states do not allow the exclusion or limitation of incidental or consequential damages, or limitations on how long an implied warranty lasts, so the exclusions may not apply to you. This warranty gives you specific legal rights and you may also have other rights which vary from state to state. If a problem with this product develops during or after the warranty period, you may contact your dealer or Service Center. If the problem is not handled to your satisfaction, then write to the warrantor's Consumer Affairs Department at the addresses listed for the warrantor.

PARTS AND SERVICE, WHICH ARE NOT COVERED BY THIS LIMITED WARRANTY, ARE YOUR RESPONSIBILITY.

Customer Services Directory (United States and Puerto Rico)

Obtain Product Information and Operating Assistance; locate your nearest Dealer or Service Center; purchase Parts and Accessories; or make Customer Service and Literature requests by visiting our Web Site at:

<http://www.panasonic.com/help>
or, contact us via the web at:
<http://www.panasonic.com/contactinfo>

You may also contact us directly at:
1-800-211-PANA (7262)
Monday-Friday 9am-9pm,
Saturday-Sunday 10am-7pm EST

For hearing or speech impaired TTY users, TTY: 1-877-833-8855

Accessory Purchases (United States and Puerto Rico)

Purchase Parts, Accessories and Instruction Books online for all Panasonic Products by visiting our Web Site at:
<http://www.pstc.panasonic.com>

Or, send your request by E-mail to:
nppcparts@us.panasonic.com
You may also contact us directly at:
1-800-332-5368 (Phone) 1-800-237-9080 (Fax Only)
(Monday-Friday 9am-9pm EST)
Panasonic National Parts Center
20421 84th Ave. S., Kent, WA 98032
(We accept Visa, MasterCard, Discover Card, American Express)

For hearing or speech impaired TTY users, TTY: 1-866-605-1277

As of January 2012

User memo:

DATE OF PURCHASE _____
DEALER NAME _____
DEALER ADDRESS _____
TELEPHONE NUMBER _____

The model number and serial number of this product can be found on either the back or the bottom of the unit. Please note them in the space provided below and keep for future reference.

MODEL NUMBER _____
SERIAL NUMBER _____

-If you see this symbol-

Information on Disposal in other Countries outside the European Union



This symbol is only valid in the European Union.
If you wish to discard this product, please contact your local authorities or dealer and ask for the correct method of disposal.



As an ENERGY STAR® Partner, Panasonic has determined that this product meets the ENERGY STAR® guidelines for energy efficiency.

Unit care

■ Clean the system with a soft, dry cloth

- When dirt is heavy, wring a cloth moistened in water tightly to wipe the dirt, and then wipe it with a dry cloth.
- When cleaning the system, use a fine cloth. Do not use tissues or other materials (towels, etc.) that can fall apart. Small grains may get stuck inside the speaker cover.
- Never use alcohol, paint thinner or benzine to clean the system.
- Before using chemically-treated cloth, carefully read the instructions that came with the cloth.

Manufactured under license from Dolby Laboratories. Dolby, Pro Logic, and the double-D symbol are trademarks of Dolby Laboratories.

Manufactured under license under U.S. Patent Nos: 5,956,674; 5,974,380; 6,487,535 & other U.S. and worldwide patents issued & pending. DTS, the Symbol, & DTS and the Symbol together are registered trademarks & DTS Digital Surround and the DTS logos are trademarks of DTS, Inc. Product includes software.
© DTS, Inc. All Rights Reserved.

The Bluetooth® word mark and logos are owned by the Bluetooth SIG, Inc. and any use of such marks by Panasonic Corporation is under license. Other trademarks and trade names are those of their respective owners.

Panasonic Consumer Marketing
Company of North America,
Division of Panasonic Corporation of
North America

One Panasonic Way, Secaucus,
New Jersey 07094

<http://www.panasonic.com>

En