

INSTALLATION INSTRUCTIONS

Modular Blower (Electric furnace)

MF080014C, MF120017C, MF160021C, MF200024C

These instructions must be read and understood completely before attempting installation.

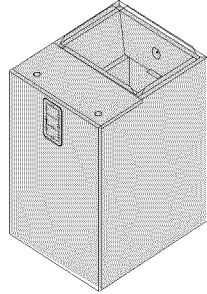

SAFETY CONSIDERATIONS

Improper installation, adjustment, alteration, service, maintenance, or use can cause explosion, fire, electrical shock, or other conditions which may cause death, personal injury, or property damage. Consult a qualified installer, service agency, or your distributor or branch for information or assistance. The qualified installer or agency must use factory-authorized kits or accessories when modifying this product. Refer to the individual instructions packaged with the kits or accessories when installing.

Follow all safety codes. Wear safety glasses, protective clothing, and work gloves. Use quenching cloth for brazing operations. Have fire extinguisher available. Read these instructions thoroughly and follow all warnings or cautions included in literature and attached to the unit. Consult local building codes, the current editions of the National Electrical Code (NEC) NFPA-70.

In Canada refer to the current editions of the Canadian Electrical Code CSA C22.1 Recognize safety information.

This is the safety-alert symbol . When you see this symbol on the unit and in instructions or manuals, be alert to the potential for personal injury. Understand these signal words; **DANGER**, **WARNING**, and **CAUTION**. These words are used with the safety-alert symbol. **DANGER** identifies the most serious hazards which **will** result in severe personal injury or death. **WARNING** signifies hazards which **could** result in personal injury or death. **CAUTION** is used to identify unsafe practices which **may** result in minor personal injury or product and property damage. **NOTE** is used to highlight suggestions which **will** result in enhanced installation, reliability or operation.

TABLE OF CONTENTS

General Information/Installation	2
Installation.....	2
Vertical/Horizontal Installation	3
Ductwork Connection.....	4
Filter Installation.....	4
Electrical Connection.....	4
Blower Performance.....	8
Sequence of Operation.....	10
Wiring Diagram.....	11
Replacement Parts	12



WARNING

ELECTRICAL SHOCK HAZARD

Failure to turn off electric power could result in personal injury or death.

Before installing or servicing system, turn off main power to the system. There may be more than one disconnect switch, including accessory heater(s).

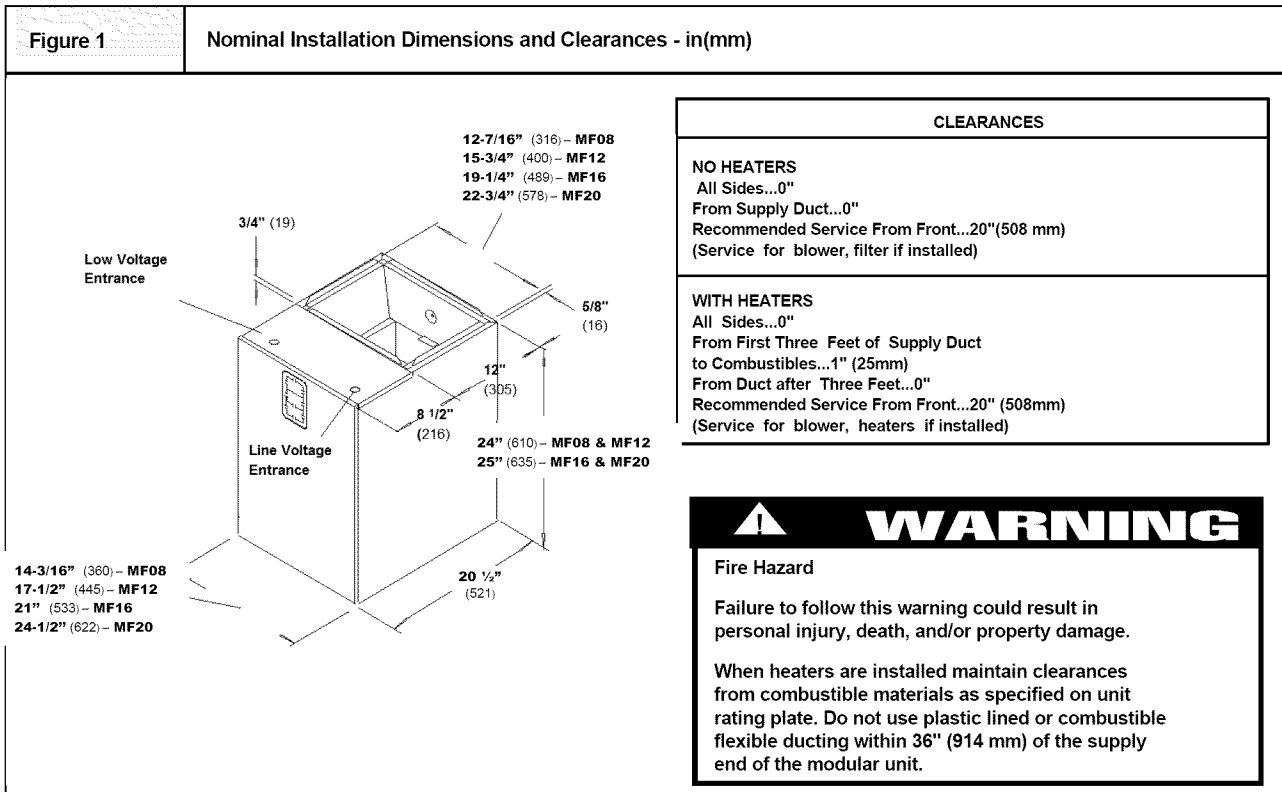

GENERAL INFORMATION

WARNING
DEATH, PERSONAL INJURY, AND/OR PROPERTY DAMAGE HAZARD Failure to carefully read and follow this warning could result in equipment malfunction, property damage, personal injury and/or death. The information contained in this manual is intended for use by a qualified service technician familiar with safety procedures and equipped with the proper tools and test instruments. Installation must conform with local building codes and with the National Electrical Code NFPA70 current edition.

INTRODUCTION

The MF modular blower cabinet uses a 208/230V PSC blower motor, with an electronic fan control board. The MF may be used for cooling or heat pump applications either with or without electric heat. Installations without electric heat require a NO HEAT KIT (EHIA00KN10). The cabinet can be installed in an upflow, downflow or horizontal position. Refer to **Figure 3 and 4**.

LOCATION

Select the best position which suits the installation site conditions. The location should provide adequate structural support, space in the front of the unit for service access, clearance for return air and supply duct connections, space for refrigerant piping connections and condensate drain line connections. If heaters are being installed,

make sure adequate clearance is maintained from supply ductwork; See Clearances and Warning in Figure 1.

If the unit is located in an area of high humidity, nuisance sweating of casing may occur. On these installations a wrap of 2" (51mm) fiberglass insulation with a vapor barrier should be used.

HEATER PACKAGES

Factory approved, field installed, UL listed heater packages are available from the equipment supplier. See unit rating plate for a list of factory approved heaters (electric heat accessory models EHIA only). Heaters that are not factory approved could cause damage which would not be covered under the equipment warranty.

CAUTION
CUT HAZARD Failure to follow this caution may result in personal injury. Sheet metal parts may have sharp edges or burrs. Use care and wear appropriate protective clothing and gloves when handling parts.

INSTALLATION

The unit is ready to install in any position without modifications. Refer to the coil instructions for information on drain pan configurations etc. Make sure coil is set up properly for desired position of blower cabinet.

Coil must be secured to blower cabinet with the three tabs that are part of the blower cabinet base. Bend the tabs out from the bottom so they fit over the coil cabinet.

Position coil cabinet in relation to the blower so they will be correct for desired application.

For upflow and horizontal applications apply foam seal strip around top of coil cabinet. For downflow application apply foam seal strip around bottom of coil cabinet. Set blower on top of coil cabinet so they are flush. Secure cabinets together using the three tabs on the bottom of the cabinet. Bend the tab out from the bottom so it fits over the coil cabinet. If no pilot holes are present, drill a hole as required for a screw.

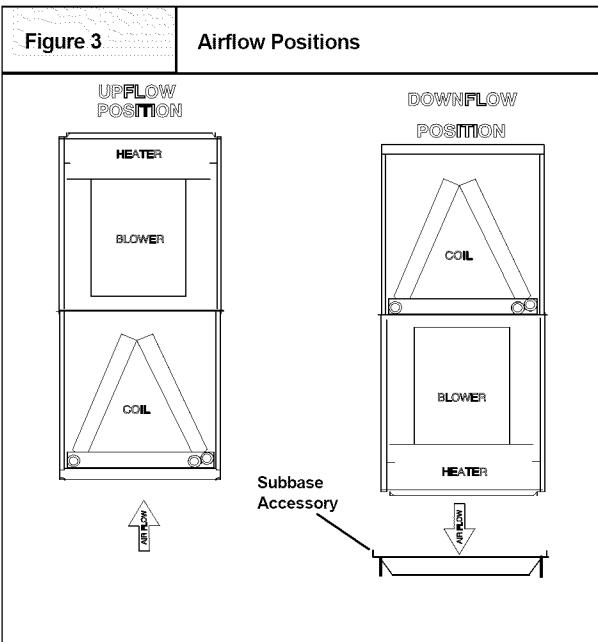
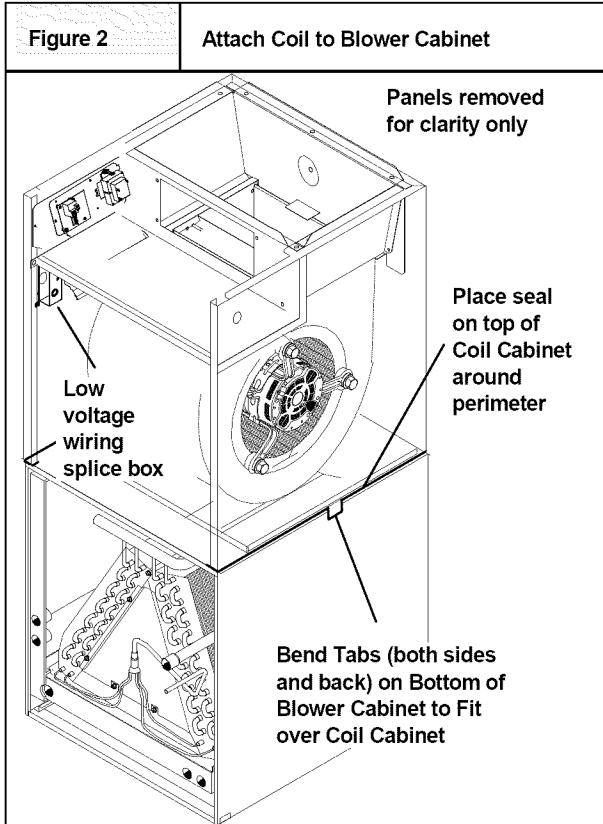

DOWNFLOW INSTALLATIONS

Refer to instructions with Subbase Kit.

NON-DUCTED RETURN AIR CLOSET INSTALLATION

The cabinet can be installed in a closet with a false bottom to form a return air plenum, or mounted on an open platform inside the closet. Platform should be high enough to provide a free (open) area for adequate return airflow into the bottom of the cabinet. The open area can be on the front side or a combination of front and sides, providing there is clearance on the sides between cabinet and closet. Refer to ACCA Manual D for sizing and free area recommendations.

NOTE: Local codes may limit application of systems without a ducted return to single story dwellings.

HORIZONTAL LEFT AND RIGHT INSTALLATIONS

The modular blower cabinets can be installed in either downflow, horizontal left or horizontal right applications. When a coil cabinet is applied, refer to the coil installation manual for proper drain pan and airflow requirements. They must have the drain pan repositioned for right hand airflow. Refer to coil installation manual.

CAUTION

PROPERTY DAMAGE HAZARD

Failure to follow this caution may result in property damage.

A field fabricated auxiliary drain pan, with a separate drain is **REQUIRED** for all installations over a finished living space or in any area that may be damaged by overflow from a restricted main drain pan. In some localities, local codes require an auxiliary drain pan for **ANY** horizontal installation.

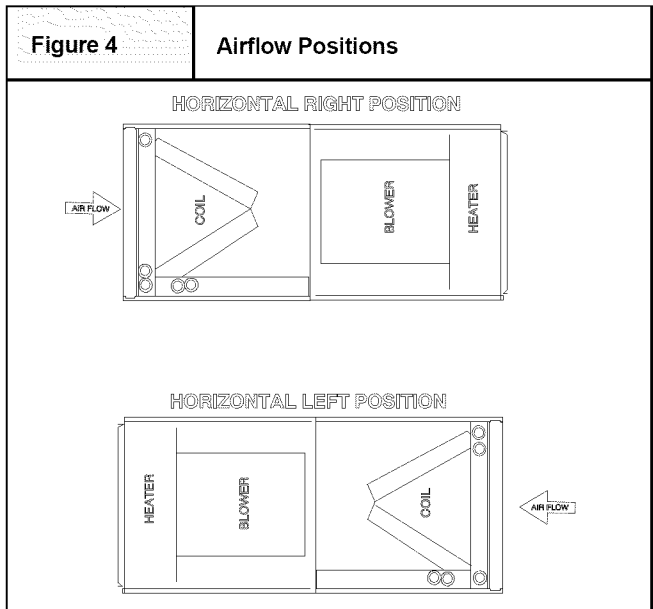

SUSPENDED CABINET INSTALLATION

1. The cabinet may be supported on a frame or shelf, or it may be suspended.

2. Use metal strapping or threaded rod with angle iron supports under the auxiliary drain pan to suspend cabinet. These supports **MUST** run parallel with the length of the cabinet. Refer to **Figure 5**.
3. Ensure that there is adequate room to remove service and access panels after installing supporting brackets.
4. Place field installed vibration isolators in auxiliary drain pan to support cabinet.

DUCT CONNECTIONS

Supply Duct

Supply duct must be attached to the outside of flange on outlet end of unit. Flexible connectors may be used if desired. Maintain clearances from supply duct to combustibles when heaters are installed. Refer to **Figure 1** and unit rating plate.

Return Duct

Return duct should be attached to bottom of unit using sheet metal screws or other fasteners.

FILTER INSTALLATION

Filters must be field supplied. A remote filter grille or other means must be provided. Refer to ACCA Manual D for remote filter sizing.

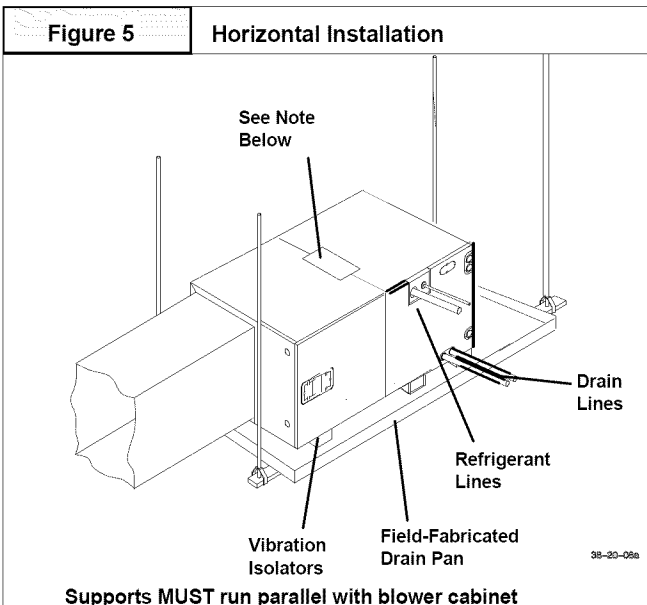

NOTE: If increased structural strength is needed in the horizontal position, use field supplied two connecting plates in place of the tabs on the bottom of the blower.

ELECTRICAL CONNECTIONS

The MF modular blower utilizes an electronic fan control board which has a low voltage circuit protective fuse (5 AMP), and pigtail connections for thermostat hook up. The fan control also has a relay for blower operation, and built in 90 second blower-off *time delay relay* (TDR). To disable the TDR feature, snip the jumper wire JW1. Refer to **Figure 6**.

All electrical work **MUST** conform with the requirements of local codes and ordinances and the National Electrical Code NFPA 70 current edition.

The low voltage transformer and the fan control are standard on all models and are prewired at the factory. Line voltage connections are made to the heater accessory or the lugs on the No Heat Kit.

WARNING

ELECTRICAL SHOCK or UNIT DAMAGE HAZARD

Failure to follow this warning could result in personal injury, death, and/or property damage.

If a disconnect switch is to be mounted on unit, select a location where drill and fasteners will not contact electrical refrigeration components.

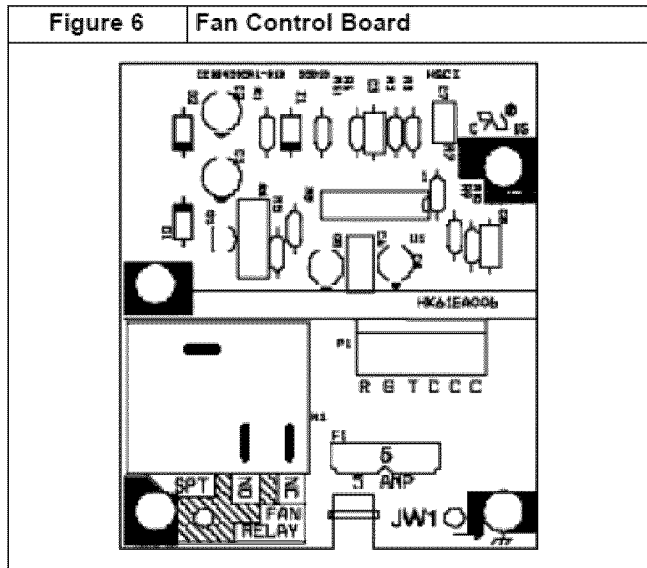

OVERCURRENT PROTECTION

The power supply wiring to the unit **MUST** be provided with overcurrent protection. Governing codes may require this to be fuses **ONLY** or circuit breakers.

For blower cabinets without heaters, a 15 amp circuit may be used.

Before proceeding with electrical connections, make certain that supply voltage, frequency, phase, and circuit ampacity are as specified on the unit rating plate. See unit wiring label for proper field high and low voltage wiring. Make all electrical connections in accordance with the NEC and any local codes or ordinances that may apply. Use copper wire only. The unit must have a separate branch electric circuit with a field-supplied disconnect switch located within sight from and readily accessible from the unit.

NOTE: When a pull-out type disconnect is removed from the unit, only the Load side of the circuit is de-energized. The Line side remains live until the main (remote) disconnect is turned off.



WARNING

ELECTRICAL SHOCK or UNIT DAMAGE HAZARD

Failure to follow this warning could result in personal injury, death, and/or property damage.

Turn OFF electric power at fuse box or service panel before making any electrical connections and ensure a proper ground connection is made before connecting line voltage.



WARNING

ELECTRICAL SHOCK HAZARD

Failure to follow this warning could result in personal injury or death.

Turn OFF the main (remote) disconnect device before working on incoming (field) wiring. Incoming (field) wiring on the line side of the disconnect found in the modular blower unit remains live, even when the pull-out is removed. Service and maintenance to incoming (field) wiring cannot be performed until the main disconnect switch (remote to the unit) is turned off.

MF units installed without electric heat require the use of a factory-authorized No Heat Kit (accessory part number EHIA00KN10). This kit provides the electrical connections necessary to supply the unit with 208/230V power when electric heat is not present.

For units without electric heat:

1. Locate adapter and filler plates with screws inside package. If necessary, adjust plates to allow for installation of No Heat Kit required inside cabinet. Refer to **Figure 7**.
2. Secure No Heat Kit accessory with four (4) screws.
3. Connect the 9-pin plug from No Heat Kit wiring into the receptacle that attaches to fan control board.
4. Connect ground wire to unit ground lug.
5. Connect 208/230V power lead from field disconnect to No Heat Kit.

For units with electric heat, see Electric Heater Installation Instructions and blower airflow requirements.

NOTE: Transformer is factory-wired for 230V operation. For 208V applications the transformer must be rewired to the 208V tap. Refer to unit wiring label.

GROUNDING CONNECTION

Use a copper conductor(s) from the ground lug on the No Heat Kit or ground lugs on the electric heater to a grounded connection in the electric service panel or a properly installed grounding rod.

Low Voltage Control Connections

Wire low-voltage in accordance with wiring label on the blower (also refer to **Figures 8 - 12**). Use 18 AWG color-coded, insulated (35°C minimum) wire to make the low-voltage connections between: thermostat, indoor equipment, and outdoor equipment. If thermostat is located more than 100 feet (31m) from the unit (as measured along the low voltage wire), use 16 AWG color-coded, insulated (35°C minimum) wire. All wiring must be NEC Class 1 and must be separated from incoming power leads. Refer to outdoor unit wiring instructions for additional wiring recommendations.

Field supplied low-voltage wiring should be field connected inside control splice box area (secure with wire nuts), and strain relief bushing or rubber grommet to seal cabinet opening.

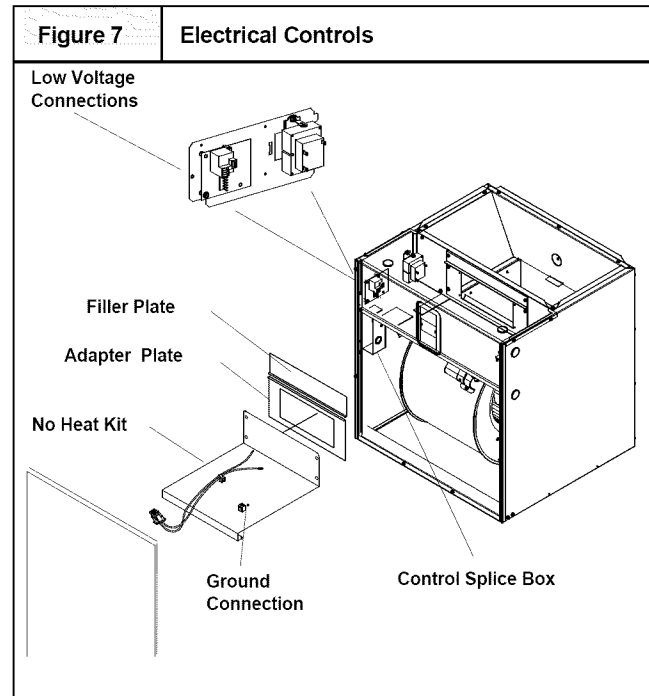
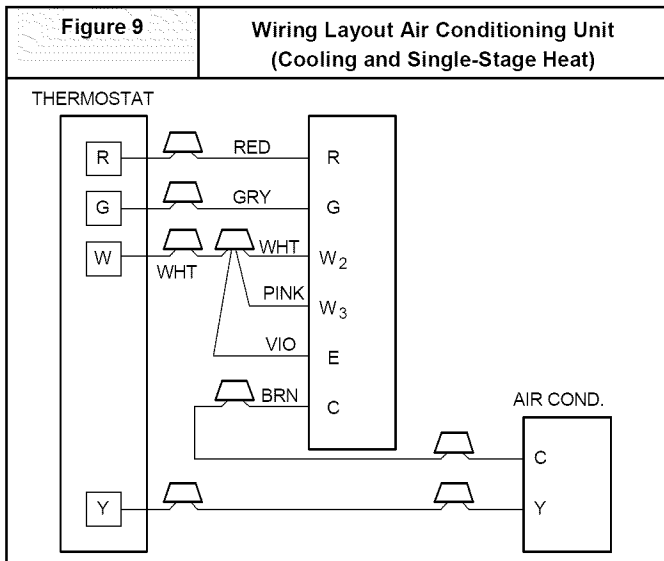
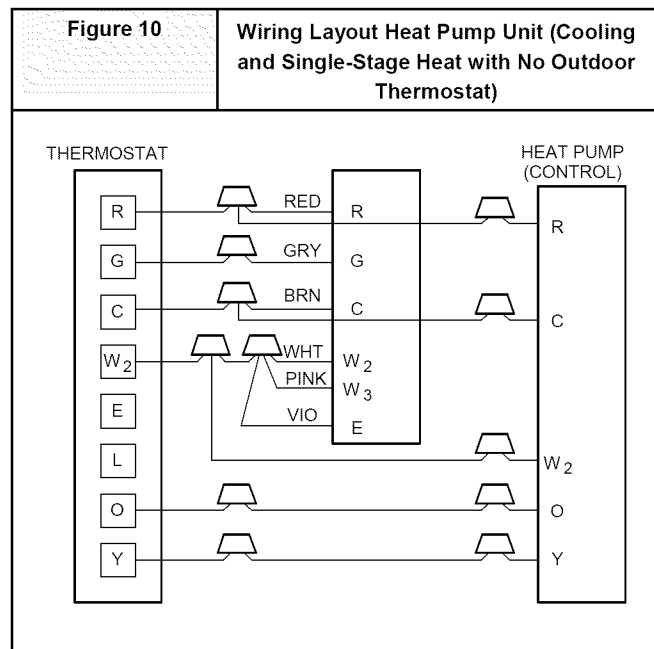
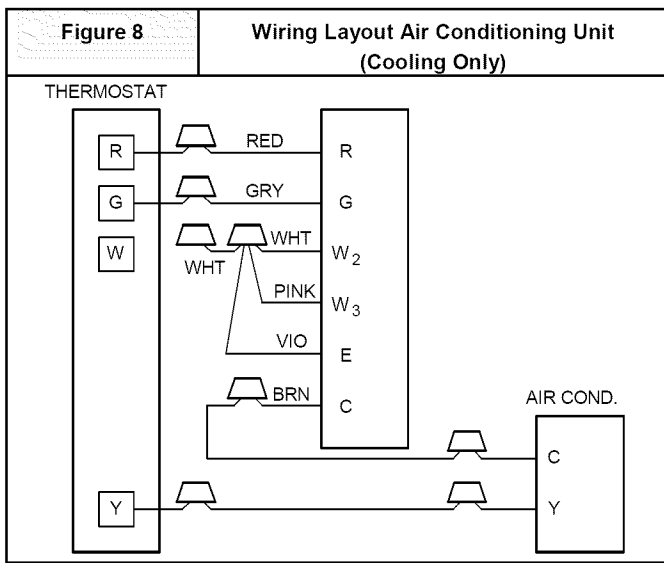
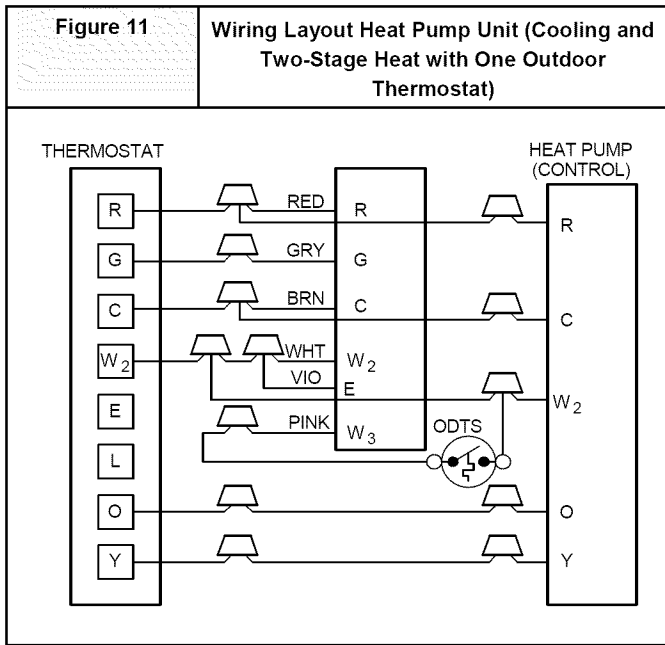

Table 1	Supply Circuit			Supply Circuit No.	H.P.	Max. Motor Amps	MCA Branch Circuit AMP	Max Over-current Protection Device (Amps)	Recommended				
	Volts	Phase	Hertz						Supply Wire 75°C copper			Ground Wire	
									# of Wires	Min Size	Max. Ft.(m) Length	# of Wires	Min Size
MF08*	208	1	60	Single	1/3	2.5	3.1	15	2	14	105 (32)	1	14
	230												
MF12*	208	1	60	Single	1/2	2.9	3.6	15	2	14	105 (32)	1	14
	230												
MF16*	208	1	60	Single	1/2	2.9	3.6	15	2	14	105 (32)	1	14
	230												
MF20*	208	1	60	Single	3/4	6.0	7.5	15	2	14	90 (27)	1	14
	230												





When two-stage electric heat is desired (refer to **Table 2 - Heat Strip Staging**), separate out the pink W3 wire from W2 & E connections. Refer to **Table 2-2** and wiring diagram **Figure 11**. W3 can be separated and controlled by the indoor wall thermostat (if multi-stage capable), or by an outdoor thermostat (ODTS). Refer to ODS kit instruction for proper wiring.

When three-stage electric heat is desired, cut the W2 wire nut off and discard. Strip W2, W3, and E. Refer to **Table 2-3**, and wiring diagram **Figures 12**. Connect according to the thermostat kit instructions or ODS kit instructions for proper wiring.

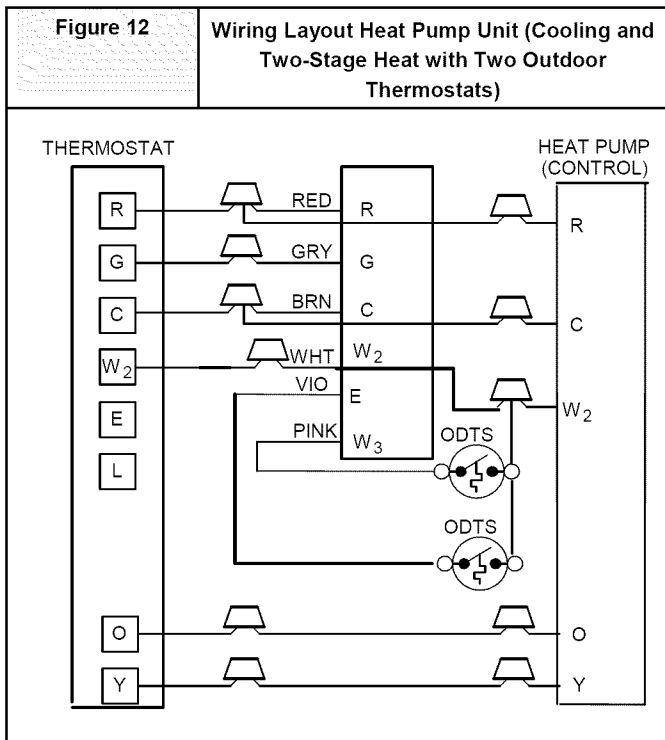

	Heat Strip Staging		
	2-1	2-2	2-3
	Single-Stage Operation (no staging - all electric heat together)	Two-Stage Capable	Three-Stage Capable (with ODS only)
Single-Phase	EHIA05KB / KN EHIA07KB / KN EHIA10KB / KN EHIA15KB EHIA20KB EHIA25KB	EHIA15KB EHIA20KB EHIA25KB	EHIA25KB10
Three-Phase	EHIA10HB EHIA15HB EHIA20HB EHIA25HB	EHIA10HB EHIA15HB EHIA20HB EHIA25HB	EHIA20HB EHIA25HB

KB is single-phase with circuit breaker
 KN is single-phase with terminal block (no-breaker)
 HB is three-phase with circuit breaker

Model	Electric Heater SIZE kW					
	5 kW	7.5 kW	10 kW	15 kW	20 kW	25 kW
MF08	LOW	LOW	LOW	MED	--	--
MF12	LOW	LOW	LOW	LOW	MED	--
MF16	LOW	LOW	LOW	MED	MED	HIGH
MF20	LOW	LOW	LOW	LOW	LOW	MED

LOW = low speed tap selection
 MED = medium speed tap selection
 HIGH = high speed tap selection

CHANGING MOTOR SPEED

To change the blower speed, disconnect the black wire at the blower motor terminal block and reconnect at the desired blower speed tap (refer to **Table 4**).

HEATER STAGING

The modular controls are factory circuited for single-stage electric heat operation. Refer to **Table 2** for available heaters and **Table 3** for unit airflow based without a coil, filter, or electric heat applied.

AIR FLOW CHECK

For proper system operation, the air flow through the indoor coil should be between 350 and 450 cfm per ton of cooling capacity. The air flow through the unit can be determined by measuring the external static pressure to the unit and selecting the motor speed tap that will most closely provide the required air flow.

1. Set up to measure external static pressure at the supply and return duct connections. Refer to **Figure 13**.
2. Drill holes in the ducts for pressure taps, pilot tubes, or other accurate pressure sensing devices.
3. Connect these taps to a level inclined manometer or draft gauge.
4. Ensure the coil and filter are clean, and all the registers are open.
5. Determine the external static pressure with the blower operating.

6. Refer to the Air Flow Data, **Table 4**, to find the speed setting that will most closely provide the required air flow for the system.
7. Refer to Motor Speeds and Airflow in these instructions if the speed is to be changed.
8. Recheck the external static pressure with the new setting, and confirm speed switch selection.

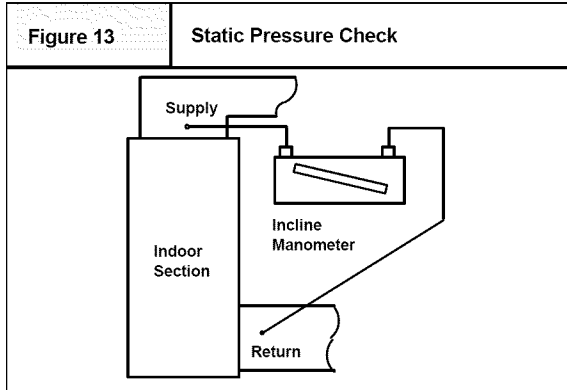

TEMPERATURE RISE CHECK

Temperature rise is the difference between the supply and return air temperatures.

NOTE: The temperature rise can be adjusted by changing the heating speed tap at the unit's blower terminal block. Refer to the unit's *Installation Instructions* for airflow information.

A temperature rise greater than 60°F (33.3°C) is not recommended.

1. To check the temperature rise through the unit, place thermometers in the supply and return air ducts as close to the unit as possible, avoiding direct radiant heat from the heater elements.
2. Open **ALL** registers and duct dampers.
3. Set thermostat Heat-Cool selector to **HEAT**.
4. Set the thermostat temperature setting as high as it will go.
5. Turn electric power **ON**.
6. Operate unit **AT LEAST** 5 minutes, then check temperature rise.

NOTE: The maximum outlet air temperature for all models is 200°F (93.3°C).

7. Set thermostat to normal temperature setting.
8. Be sure to seal all holes in ducts if any were created during this process.

Airflow Based on no coil, no filter, no electric heat. Deduct heater static shown in heater static table. Deduct coil static, See Coil Specification Sheet. Deduct .20 in wc (50 Pa) for Downflow Subbase Kit.

Table 4		Airflow is blower only, no coil attached						
MF08		In wc						
SPEED	VOLTS	0.20	0.30	0.40	0.50	0.60	0.70	0.80
Low	230v	1029	1020	1007	985	960	915	862
	208v	872	860	845	825	797	765	721
Med	230v	1286	1270	1254	1220	1180	1125	1058
	208v	1113	1105	1091	1070	1042	1000	947
High	230v	1500	1470	1432	1380	1315	1250	1168
	208v	1317	1305	1286	1255	1220	1170	1008
MF012		In wc						
SPEED	VOLTS	0.20	0.30	0.40	0.50	0.60	0.70	0.80
Low	230v	973	975	979	979	973	955	931
	208v	811	815	816	810	797	780	749
Med	230v	1284	1295	1301	1305	1302	1280	1246
	208v	1084	1084	1084	1090	1089	1065	1030
High	230v	1663	1670	1671	1655	1631	1585	1519
	208v	1383	1385	1390	1390	1383	1365	1328
MF16		In wc						
SPEED	VOLTS	0.20	0.30	0.40	0.50	0.60	0.70	0.80
Low	230v	1020	1015	1009	1002	991	975	950
	208v	858	845	830	815	801	780	749
Med	230v	1379	1385	1386	1379	1364	1343	1309
	208v	1156	1154	1149	1144	1134	1120	1098
High	230v	1776	1782	1783	1765	1736	1698	1643
	208v	1496	1496	1496	1495	1495	1470	1433
MF20		In wc						
SPEED	VOLTS	0.20	0.30	0.40	0.50	0.60	0.70	0.80
Low	230v	1492	1495	1492	1475	1451	1395	1308
	208v	1246	1245	1238	1225	1203	1175	1125
Med	230v	1969	1955	1935	1890	1818	1700	1570
	208v	1641	1640	1633	1615	1584	1510	1406
High	230v	2696	2600	2492	2350	2192	2020	1844
	208v	2417	2355	2287	2200	2092	1940	1774

* THE MAXIMUM EXTERNAL STATIC PRESSURE IS 0.8" W.C., WITHOUT COOLING COIL. DEDUCT STATIC PRESSURE OF COIL FOR MAXIMUM STATIC PRESSURE.

Table 5 - ELECTRIC HEATER STATIC PRESSURE DROP

Single-Phase						
CFM	EHIA 05	EHIA 07	EHIA 10	EHIA 15	EHIA 20	EHIA 25
In wc						
600	0.01	0.01	0.01	—	—	—
700	0.01	0.01	0.01	—	—	—
800	0.01	0.01	0.01	0.01	—	—
900	0.01	0.01	0.01	0.01	—	—
1000	0.01	0.01	0.01	0.01	0.02	—
1100	0.01	0.01	0.01	0.02	0.02	—
1200	0.01	0.01	0.01	0.02	0.02	—
1300	0.01	0.02	0.02	0.02	0.02	—
1400	0.01	0.02	0.02	0.02	0.03	0.03
1500	0.01	0.02	0.02	0.02	0.03	0.04
1600	0.01	0.02	0.02	0.03	0.03	0.04
1700	0.01	0.02	0.02	0.03	0.03	0.04
1800	0.01	0.02	0.02	0.03	0.04	0.04
1900	0.01	0.02	0.02	0.03	0.04	0.05
2000	0.01	0.02	0.02	0.03	0.04	0.05

Three-Phase						
CFM	N/A	N/A	EHIA 10	EHIA 15	EHIA 20	EHIA 25
In wc						
600			0.01	—	—	—
700			0.01	—	—	—
800			0.01	0.01	—	—
900			0.01	0.01	—	—
1000			0.01	0.01	0.02	—
1100			0.01	0.02	0.02	—
1200			0.01	0.02	0.02	—
1300			0.02	0.02	0.02	—
1400			0.02	0.02	0.03	0.03
1500			0.02	0.02	0.03	0.04
1600			0.02	0.03	0.03	0.04
1700			0.02	0.03	0.03	0.04
1800			0.02	0.03	0.04	0.04
1900			0.02	0.03	0.04	0.05
2000			0.02	0.03	0.04	0.05

ACCESSORIES

ELECTRIC AIR CLEANER

The Electronic Air Cleaner may be connected to MF as shown in Figure 14. This method requires a field supplied transformer. See Electronic Air Cleaner literature for kit requirements.

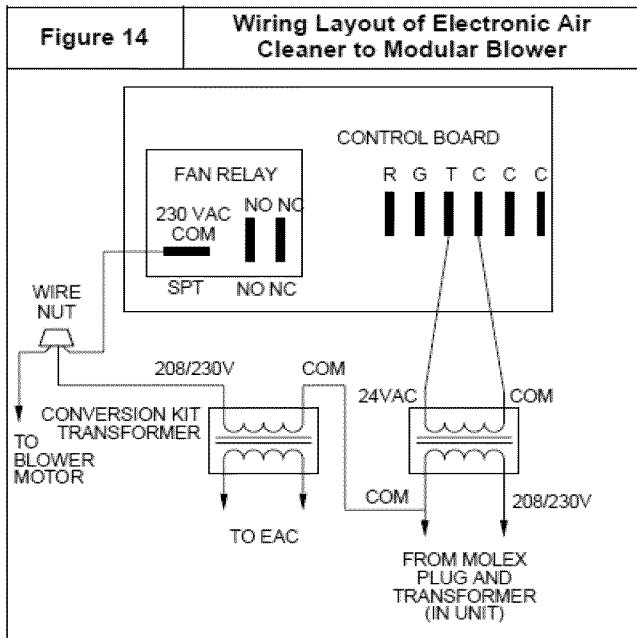

HUMIDIFIER

Connect humidifier and humidistat to modular blower unit as shown in Figures 15 and 16.

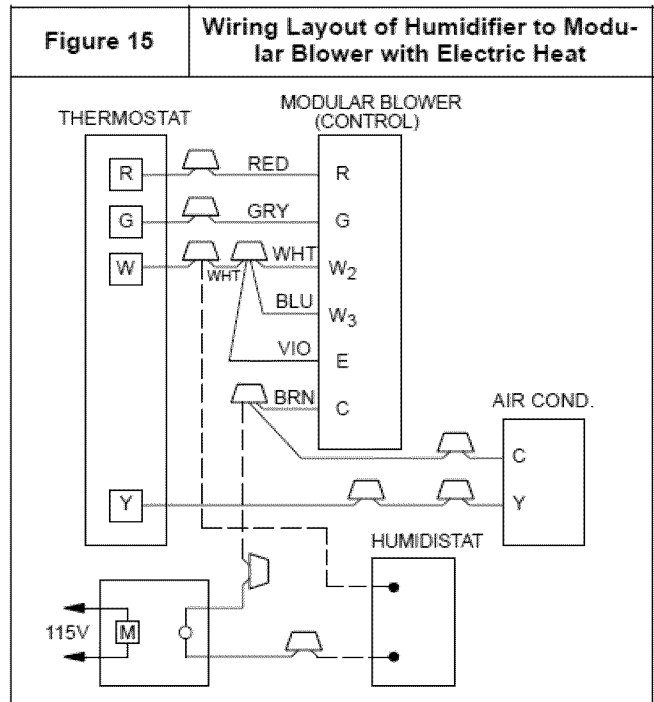

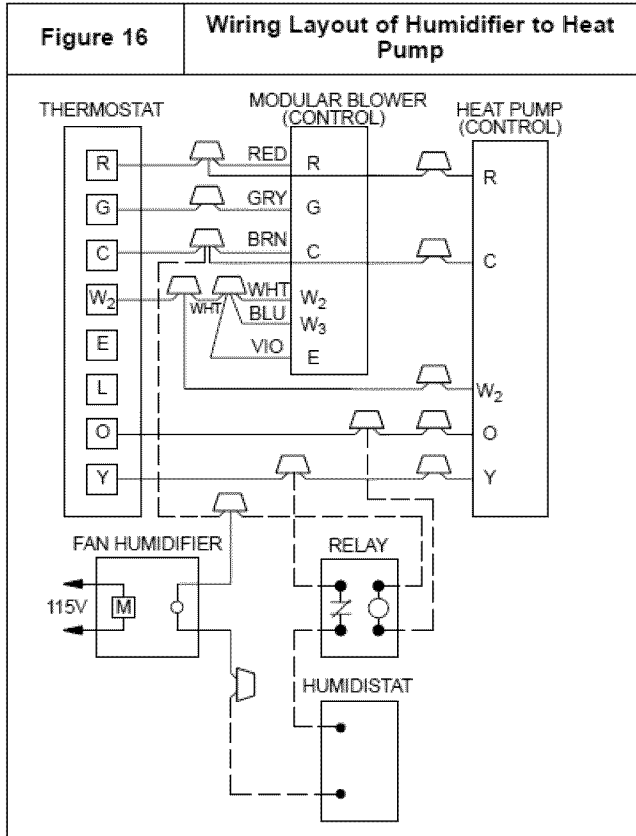

SEQUENCE OF OPERATION

A. CONTINUOUS FAN

Thermostat closes R to G. G energizes fan relay on FAN CONTROL BOARD which completes the high voltage circuit to indoor blower motor. When G is de-energized, there is a built in 90 second blower-off *time delay relay* (TDR). To disable the TDR feature, snip the jumper wire JW1.

B. COOLING MODE

Air Conditioner Only:

Thermostat energizes R to G and Y. G energizes fan relay on fan control board which completes high-voltage circuit to indoor blower motor. Y energizes the 24 low-voltage contactor in condensing unit. When call is satisfied, Y drops out and there is a 90 second blower TDR before fan relay opens.

Heat Pump:

Same as above - except thermostat will also energize O for reversing valve operation in cooling mode. O will typically remain energized by the thermostat (after cooling call is satisfied), or until the mode is changed to heating.

C. HEAT PUMP

Cooling Mode:

Thermostat energizes R to G, Y and O. G energizes indoor fan relay on fan control board which completes high-voltage circuit to indoor

blower motor. Y energizes the outdoor 24V low-voltage circuit in heat pump to energize compressor. O energizes reversing valve in cooling mode and typically remains energized until the mode is changed to heating. When thermostat cooling call is satisfied, Y drops out. O remains energized, and there is a 90 second TDR before indoor fan relay opens.

Heating Mode:

Thermostat energizes R to G and Y only (no O signal in heating). G energizes indoor fan relay on fan control board which completes high-voltage circuit to indoor blower motor. Y energizes the outdoor 24V low-voltage circuit in heat pump to energize compressor. The reversing valve is not energized in heating unless a defrost cycle should occur. When call is satisfied, Y drops out and there is a 90 second TDR before indoor fan relay opens.

D. HEAT PUMP HEATING WITH AUXILIARY ELECTRIC HEAT

Cooling Mode:

Same operation as above in Heat Pump Cooling Mode.

Heating Mode:

Same operation as above in Heat Pump Heating Mode with the addition of W. Thermostat energizes R to G, Y, and W. W energizes electric heat relay(s) which completes circuit to heater element(s). When W is de-energized, electric heat relay(s) open, turning off heater elements. The White wire in pigtail connects W2, W3, and E together. This may be separated for heater staging when available, see electric heat kit for more information.

E. ELECTRIC HEAT OR EMERGENCY HEAT MODE

Thermostat closes R to W. W energizes electric heat relay(s) which completes circuit to heater elements(s). Blower motor is energized through N.C. (normally closed) contacts on fan relay. When W is de-energized, electric heat relay(s) opens.

CARE AND MAINTENANCE

The system should be regularly inspected by a qualified service technician. Consult the servicing dealer for recommended frequency. Between visits, the only consumer service recommended or required is air filter maintenance and condensate drain operation.

AIR FILTER

Inspect air filters at least monthly and replace or clean as required. Disposable type filters should be replaced. Reusable type filters may be cleaned by soaking in mild detergent and rinsing with cold water. The frequency of cleaning depends upon the hours of operation and the local atmospheric conditions. Install filters with the arrows on the side pointing in the direction of air flow. Clean filters keep unit efficiency high.

LUBRICATION

The bearings of the blower motor are permanently lubricated.

CONDENSATE DRAINS

During the cooling season check the condensate drain lines to be sure that condensate is flowing from the primary drain but not from the secondary drain. If condensate ever flows from the secondary drain, the unit should be promptly shut off and the condensate pan and drains cleaned to insure a free flowing primary drain.

WIRING DIAGRAM

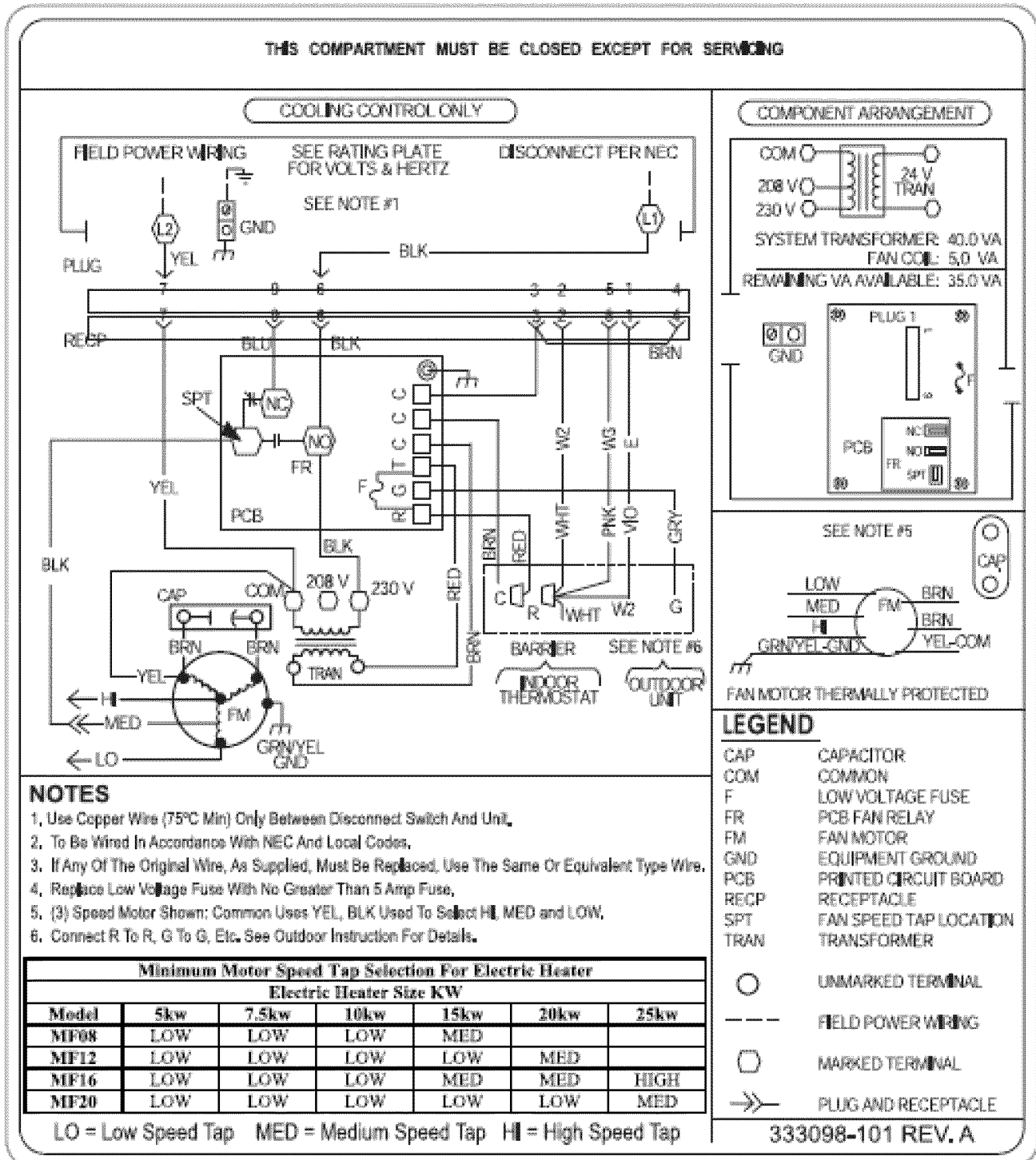

REPLACEMENT PARTS

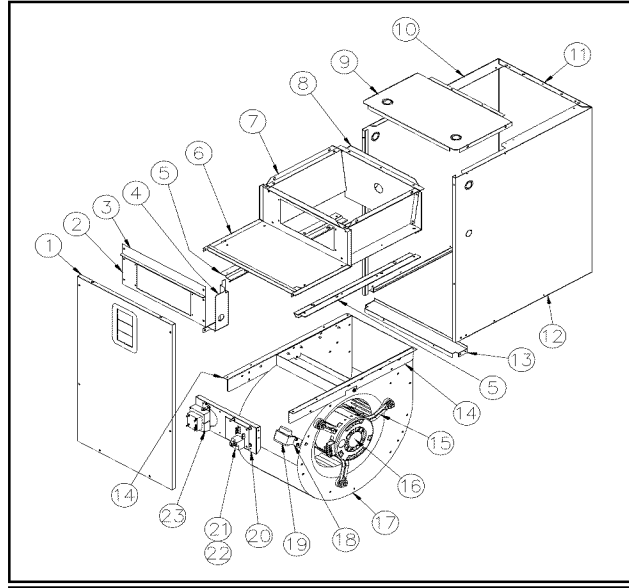

ITEM NO.	CURRENT PART#	DESCRIPTION				
			MF080014C1	MF120017C1	MF160021C1	MF200024C1
1	B60077-13	BLOWER DOOR ASSY	1	-	-	-
	B60077-14		-	1	-	-
	B60077-15		-	-	1	-
	B60077-16		-	-	-	1
2	B60029	PLATE HEATER ADAPTER	-	1	1	1
3	B60048	PLATE HEATER FILLER	-	-	1	1
4	B60106	WIRE CHANNEL	1	1	1	1
5	B60107	DECK BLOWER RAIL RIGHT/LEFT	2	2	2	2
6	B60093	FRONT BLOWER DECK	1	-	-	-
	B60094		-	1	-	-
	B60095		-	-	1	-
	B60096		-	-	-	1
7	B60101	SIDE BLOWER DECK	2	-	-	-
	B60102		-	2	-	-
	B60103		-	-	2	-
	B60104		-	-	-	2
8	B60097	REAR BLOWER DECK	1	-	-	-
	B60098		-	1	-	-
	B60099		-	-	1	-
	B60100		-	-	-	1
9	B60076-01	PANEL TOP ASS'Y	1	-	-	-
	B60076-02		-	1	-	-
	B60076-03		-	-	1	-
	B60076-04		-	-	-	1
10	B60089-02	LEFT SIDE WRAPPER	1	1	-	-
	B60090-02		-	-	1	1
11	B60087-01	BACK WRAPPER	1	-	-	-
	B60087-02		-	1	-	-
	B60088-01		-	-	1	-
	B60088-02		-	-	-	1
12	B60089-01	RIGHT SIDE WRAPPER	1	1	-	-
	B60090-01		-	-	1	1

ITEM NO.	CURRENT PART#	DESCRIPTION				
			MF080014C1	MF120017C1	MF160021C1	MF200024C1
13	B60105-01	BRACE, BOTTOM/FRONT	1	-	-	-
	B60105-02		-	1	-	-
	B60105-03		-	-	1	-
	B60036-04		-	-	-	1
14	B60108	BLOWER RAIL RIGHT/LEFT	1	1	1	1
15	E01888-01	MOTOR MOUNT ASSY (BAND AND LEGS)	1	1	1	-
	E01888-02		-	-	-	1
16	E01880-03	MOTOR ASSY (WITH MOTOR MOUNTS)	1/3-P - 3Spd	1	-	-
	E01880-05		1/2-P - 3Spd	-	1	-
	E01880-07		1/2-P - 3Spd	-	-	1
	E01880-09		3/4-P - 3Spd	-	-	1
17	ZD11027	BLOWER HOUSING WITH WHEEL	100-7R	1	-	-
	ZD11028		100-8R	-	1	-
	ZD11029		100-9R	-	-	1
18	E01024	CAPACITOR SUPPORT	1	1	1	1
19	L011003	CAPACITOR	370V/10MF	1	1	1
	L011005		370V/15MF	-	-	1
20	B60109-01	BRACKET CTL MITG	1	-	-	-
	B60109-02		-	1	-	-
	B60109-03		-	-	1	1
21	R98G010	FAN CONTROL BOARD	1	1	1	1
22	B60087	WIRE HARNESS	1	1	1	1
23	L01F012	TRANSFORMER 208/230-24v, 40VA	1	1	1	1

International Comfort Products, LLC
Lewisburg, TN 37091 USA