



SIDE BY SIDE REFRIGERATOR

RS265LA**
RS267LA**
RS269LA**

Write the model and serial number here:

Model # _____

Serial # _____

Find these numbers on a label of the refrigerator's cabinet on the left hand-side wall.

OWNER'S MANUAL AND INSTALLATION

CONTENTS

<hr/>	
<i>SAFETY WARNING SIGNS</i>	2
<i>OPERATING INSTRUCTIONS</i>	4
SETTING UP THE REFRIGERATOR.....	4
MAJOR FEATURES.....	4
CONTROL PANEL.....	5
DIGITAL PANEL.....	6
TEMPERATURE CONTROL.....	7
ICE and COLD WATER DISPENSER.....	7
SHELVES and BINS.....	8
FOOD STORAGE GUIDE.....	9
CoolSelect Zone™ Drawer GUIDE.....	11
REMOVING THE FREEZER ACCESSORIES.....	13
REMOVING THE REFRIGERATOR ACCESSORIES.....	13
CLEANING THE ACCESSORIES.....	14
CHANGING THE INTERIOR LIGHT.....	15
WATER FILTER.....	16
DOORS.....	16
<i>INSTALLATION INSTRUCTIONS</i>	17
INSTALLATION OF THE REFRIGERATOR.....	17
REMOVING THE REFRIGERATOR DOORS.....	18
REATTACHING THE REFRIGERATOR DOORS.....	21
LEVELING REFRIGERATOR.....	24
ADJUSTING THE CLEARANCE BETWEEN THE DOORS.....	25
CHECKING THE WATER DISPENSER LINE.....	26
INSTALLING THE WATER DISPENSER LINE.....	27
TROUBLESHOOTING.....	29
<i>CONSUMER SUPPORT</i>	30
WARRANTY.....	30

In the U.S. for questions about features, operation/performance, parts, accesories or service, call:

1-800-726-7864 (1-800-SAMSUNG)
www.samsung.com

Register your product at www.samsung.com/global/register

DA68-01506B REV(0.4)

SAFETY WARNINGS



WARNING

- Before operating the appliance, please read and retain this manual thoroughly for your reference.
- Because these following operating instructions cover various models, the characteristics of your refrigerator may differ slightly from those described in this manual.
- The appliance is not intended for use by children or infirm persons without adult supervision.
- Children should be supervised to ensure that they do not play with the appliance.

CAUTION/WARNINGS USED

 WARNING	Indicates that a danger of death or serious injury exists.
 CAUTION	Indicates that a risk of personal injury or material damage exists.

OTHER SIGNS USED

	Represents something you must NOT do.
	Represents something you must NOT disassemble.
	Represents something you must NOT touch.
	Represents something you must follow.
	Indicates that you must disconnect the power plug from the socket.
	Represents that a ground is needed to prevent electric shock.
	It is recommended that this should be handled by a service center.

To prevent injury to users or other persons, please follow the safety warning signs. After reading these owner's manual, please keep it in a safe place for reference.



WARNING SIGNS



Do not plug several appliances into the same multiple receptacle.

- This could cause overheating and the risk of fire.

Make sure that the power plug is not squashed or damaged by the back of the refrigerator .

- A damaged power plug may cause overheating and fire.

Do not directly spray water inside or outside the refrigerator/ freezer.

- There is a risk of electric shock.

Do not use aerosols near the refrigerator .

- There is a risk of explosion or fire.

Do not bend the power cord excessively or place heavy articles on it .

- This constitutes a fire hazard. If the power cord is damaged, have it replaced immediately by the manufacturer or its service agent.

Do not insert the power plug with wet hands.

- You may receive an electric shock.

Do not put a container filled with water on the refrigerator.

- If spilled, there is a risk of fire or electric shock.

Do not install the refrigerator in a damp place or a place where it may come in contact with water.

- Deteriorated insulation of the electrical parts may cause electric shock or fire.

Do not store volatile or flammable substances in the refrigerator.

- The storage of benzene, thinner, alcohol, ether, LP gas and other such products may cause explosions.



Do not disassemble or repair the refrigerator by yourself.

- You run the risk of causing a fire, malfunctions and/or personal injury.



Pull the power plug out of the socket before changing the refrigerator's interior light.

- Otherwise, there is a risk of electric shock.



If you wish to dispose of the refrigerator, throw it away by first removing the doors and seals.

- Do so in a way that it is not possible for a child to remain trapped inside.



The refrigerator must be grounded.

- You must ground the refrigerator to prevent any power leakages or electric shocks caused by current leakage from the refrigerator.



Never use gas pipes, telephone lines or other potential lightning rods as ground.

- Improper use of the ground plug can result in a risk of electric shock. If it is necessary to use an extension cord, use only a 3-wire extension cord that has a 3-blade ground plug and a 3-slot receptacle that will accept the plug on the appliance. The marked rating of the extension cord should be AC 115V~120V, 10A, or more. If a grounding adapter is used, make sure the receptacle box is fully grounded.

SAFETY WARNINGS



CAUTION SIGNS



Do not overfill the refrigerator with food.

- When you open the door, an item may fall out and cause personal injury or material damage.

Do not put bottles or glass containers in the freezer.

- When the contents freeze, the glass may break and cause personal injury.

If the wall socket is loose, do not insert the power plug.

- There is a risk of electric shock or fire.



Do not disconnect the power cord by pulling on it.

- Damage to the cord may cause a short-circuit, fire and/or electric shock.
- If the power cord is damaged, it must be replaced by the manufacturer, a certified service agent or qualified service personnel.

Do not store articles on the top of the appliance.

- When you open or close the door, the articles may fall and cause personal injury and/or material damage.

Do not store pharmaceutical products, scientific materials and temperature-sensitive products in the refrigerator.

- Products that require strict temperature controls must not be stored in the refrigerator.

Do not let children hang on the door because a serious injury may occur.

If you sense pharmaceutical smells or smoke, pull out the power plug immediately and contact your SAMSUNG Electronics service center.



Do not touch the inside walls of the freezer or products stored in the freezer with wet hands.

- It may cause frostbite.

Do not insert your hands into the bottom area under the appliance.

- Any sharp edges may cause personal injury.

Never put fingers or other objects into the dispenser hole and ice chute. It may cause personal injury or material damage



DANGER

Risk of child entrapment. Before you throw away your old refrigerator or freezer

- Take off the doors
- Leave the shelves in places so that children may not easily climb inside.

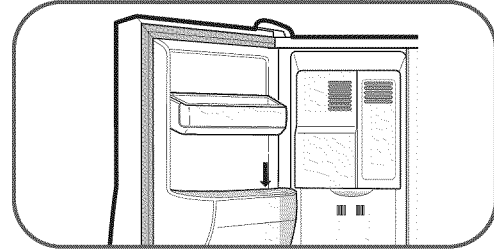

Do not use a wet or damp cloth when cleaning the plug. Remove any foreign matter or dust from the power plug pins.

- Otherwise there is a risk of causing a fire.

- If the refrigerator is disconnected from the power supply, you should wait for at least five minutes before plugging it back in.



If the refrigerator is not to be used for a long period of time, pull out the power plug.

- Deterioration in the insulation may cause fire.



- The appliance is not intended for use by young children or infirm persons without supervision. Young children should be supervised to ensure that they do not play with the appliance.

- Do not place the equipment directly under the sunlight, etc.

- The appliance must be positioned so that the plug is accessible after installation.

- If the power cord is damaged, it must be replaced by the manufacturer, a certified service agent or a qualified service personnel.

- If you have a long vacation planned, empty the refrigerator and turn it off. Wipe excess moisture from the inside and leave the doors open. Otherwise, odor and mold may develop.



Service warranty section

- Any changes or modifications performed by a 3rd party on a finished product is not covered under Samsung warranty service

Safety Caution section

- Samsung does not recommend 3rd party modification, therefore Samsung is not responsible for safety issues that result from 3rd party modifications.

SETTING UP THE REFRIGERATOR

Once you have performed the following steps, your refrigerator should be fully operational. If not, check the power supply and electricity source. If you have any questions, contact your **SAMSUNG** service center.

1 Place the refrigerator in an appropriate location with reasonable clearance between the wall and the refrigerator. (refer to installation instructions in this manual)

3 Set the temperature control to the coldest temperature and wait for an hour. The freezer should get slightly chilled and the motor should run smoothly.

2 When the refrigerator is plugged in, the interior light should come on when you open the doors.

4 Once the refrigerator temperature is sufficiently low, you can store food in the refrigerator. After starting the refrigerator, it takes a few hours to reach the appropriate temperature.

MAJOR FEATURES

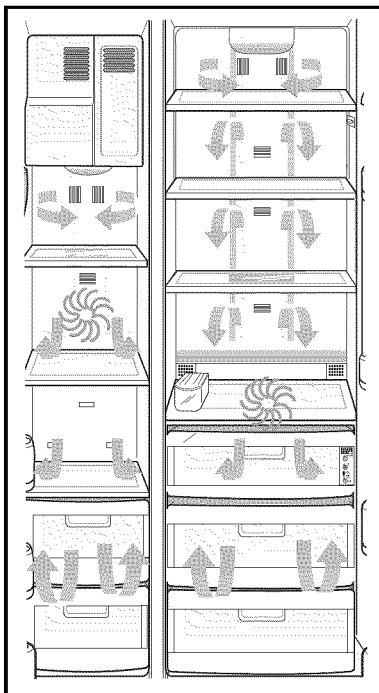

Twin Cooling System

- The refrigerator and the freezer have two evaporators. Given this independent system, the freezer and the refrigerator are cooled individually and are, therefore, more efficient. Food odor from the refrigerator does not affect food in the freezer due to separate air flow circulation.

Multi-Flow System

- Cool air circulates through multiple vents on every shelf level. This provides even distribution of cooling inside cabinets to keep your food fresh longer.

Xtra Space™

- Vertical room next to the ice maker in the freezer provides space for pizza etc.

Door Alarm

- Beeper reminds you that the door is open.

Xtra Fresh™

- Optimized humidity control keeps vegetables & fruits fresh.

Deodorizer

- Reusable deodorizer keeps the refrigerator air fresh and odor free.

CoolSelect Zone™ Drawer (RS267/RS269)

- User can select Quick Cool, Thaw and Select buttons to quickly chill, thaw and cool items. Select Soft Freeze, Cool or Chill to control the temperature of drawer.

CONTROL PANEL

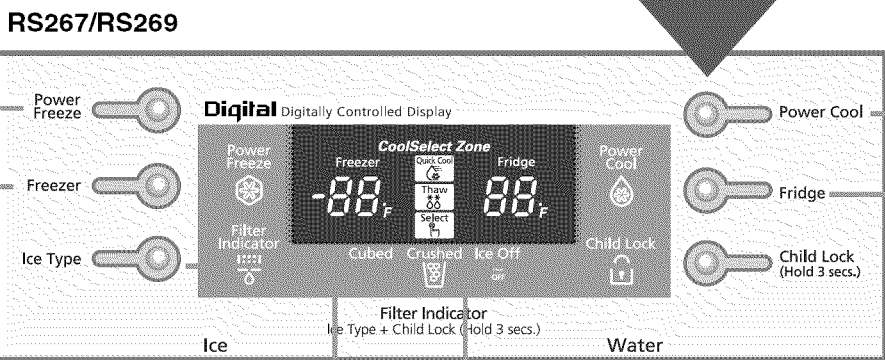
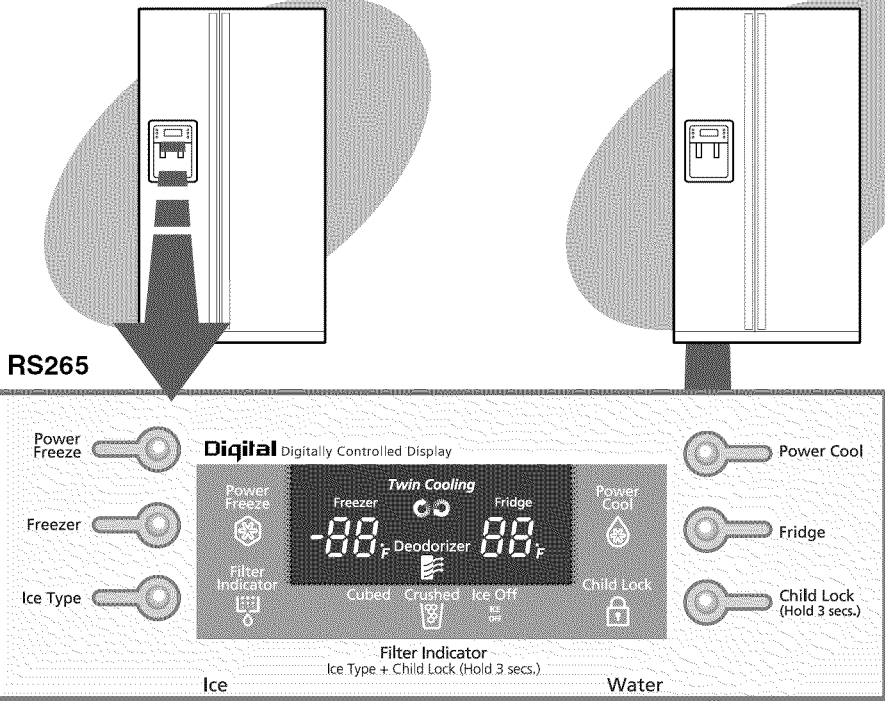

FREEZER BUTTON
To set the freezer temperature, press the button repeatedly to change the set temperature in sequence between 8°F and -14°F.

FRIDGE BUTTON
To set the fridge temperature, press the button repeatedly to change the set temperature in sequence between 34°F and 46°F.

POWER FREEZE BUTTON
Speeds up the freezing process in the freezer.

POWER COOL BUTTON
Speeds up the cooling process in the refrigerator

ICE TYPE BUTTON
Use this button to choose Cubed or Crushed Ice or Ice off.

CHILD LOCK BUTTON
When this button is pressed for 3 sec., the Power Freeze, Power Cool, Freezer Temp. and Fridge Temp. are locked and can not be modified. The Water and Ice dispensers are not locked and can still be used. To cancel this function, press Child Lock button again.

OPERATING INSTRUCTIONS

DIGITAL PANEL

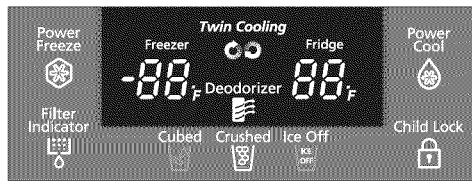

RS265

OR

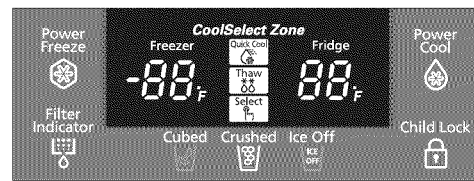

RS267/RS269

Freezer indicates the current freezer temperature.
Fridge indicates the current refrigerator temperature.
Quick Cool, Thaw, and Select show the status of the CoolSelect Zone™ Drawer

Power Freeze



- This light goes on when you press the Power Freeze button.
Press this button to quickly return the freezer to its set temperature.
- If you need much ice, you can get ice faster.
- Press the button again to cancel the Power Freeze mode.
- ❗ If you use this function, energy consumption will increase.
Please turn off when not using this function.

Power Cool



- This light goes on when you press the Power Cool button.
Press this button to quickly return the refrigerator to its set temperature.
- Press this button again to cancel the Power Cool mode.

Deodorizer



- This light indicates that the reusable twin deodorizers are in operation.
- Reactivate the deodorizing cartridge once or twice a year (see “Cleaning the Accessories” section)

Cubed Ice, Crushed Ice and Ice Off



- Press the Ice Type button in sequence to choose Cubed Ice, Crushed Ice or Ice Off to stop making ice.
- Lit icon indicates the ice type currently chosen.

Filter Indicator



- Change filter every 6 months. If indicator is orange, the filter has 1 month left. If indicator is red, quick replacement is strongly recommended.
- When the water filter is replaced, reset the indicator by pressing the Ice Type button and the Child Lock buttons simultaneously for 3 seconds.
- To turn this indicator off, press the Ice Type and Child Lock buttons simultaneously and hold for 5 seconds.

TEMPERATURE CONTROL

Freezer

- The freezer temperature can be set between 8°F and -14°F.
- Press the **Freezer** button **repeatedly** until the desired set temperature is shown in the temperature display.
- The temperature display changes in sequence between 8°F and -14°F. When the display reaches 8°F, it returns to -14°F.
- After five seconds, the display reverts to the actual freezer temperature. The unit will then work to adjust to the new desired temperature.

Refrigerator

- The refrigerator temperature can be set between 46°F and 34°F.
- Press the **Fridge** button repeatedly until the desired temperature is shown in the temperature display.
- The temperature display changes in sequence and reverts in the same way as the freezer.





WARNING

- When ice cream is stored above 4°F in freezer, it may melt.
- The temperature of the freezer or the refrigerator rises from frequent openings and from warm food. This may cause the digital display to blink. The digital display will stop blinking when the freezer and refrigerator return to normal temperature.

If the temperature control does not reset temp, unplug the refrigerator, wait 9 min, then plug it back in.

ICE and COLD WATER DISPENSER

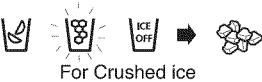
Press the Ice Type button to select the type of ice:

- Cubed ice  For Cubed ice
- Crushed ice  For Crushed ice
- No ice  For ice off



NOTE

If the Ice remains in the Ice bucket, cubed ice is obtained. Ice stays in cube form and is crushed when the Crushed ice button is pressed.

Push the ice dispenser lever with a cup.

- Place a cup in line with the dispenser to prevent the ice from jumping out.

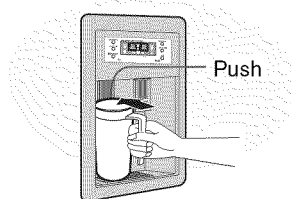

NOTE

To avoid injury, never put fingers or any other objects in the dispenser opening.

Water Dispenser

The capacity of the water tank is approximately 0.3 gal.

Cold Water

- Push the water dispenser lever with a cup.
- If you have just installed the refrigerator or installed a new water filter, throw away the first six glassfuls of water or until water flows cleanly to flush out impurities in the water supply system.

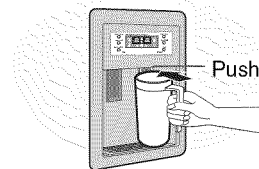

CAUTION

If you have a long period of time (long vacation or business trip) and won't use the water or ice dispensers, close the water valve and shut off the water supply to the refrigerator. Otherwise, water leakage may occur.

SHELVES AND BINS

Freezer

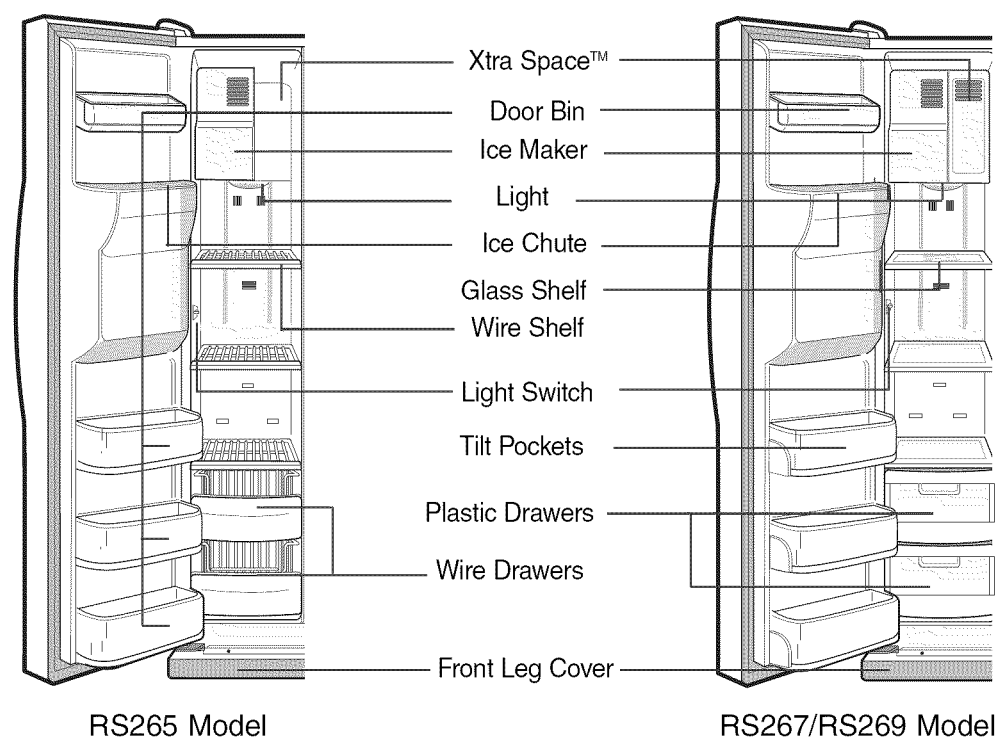

Refrigerator

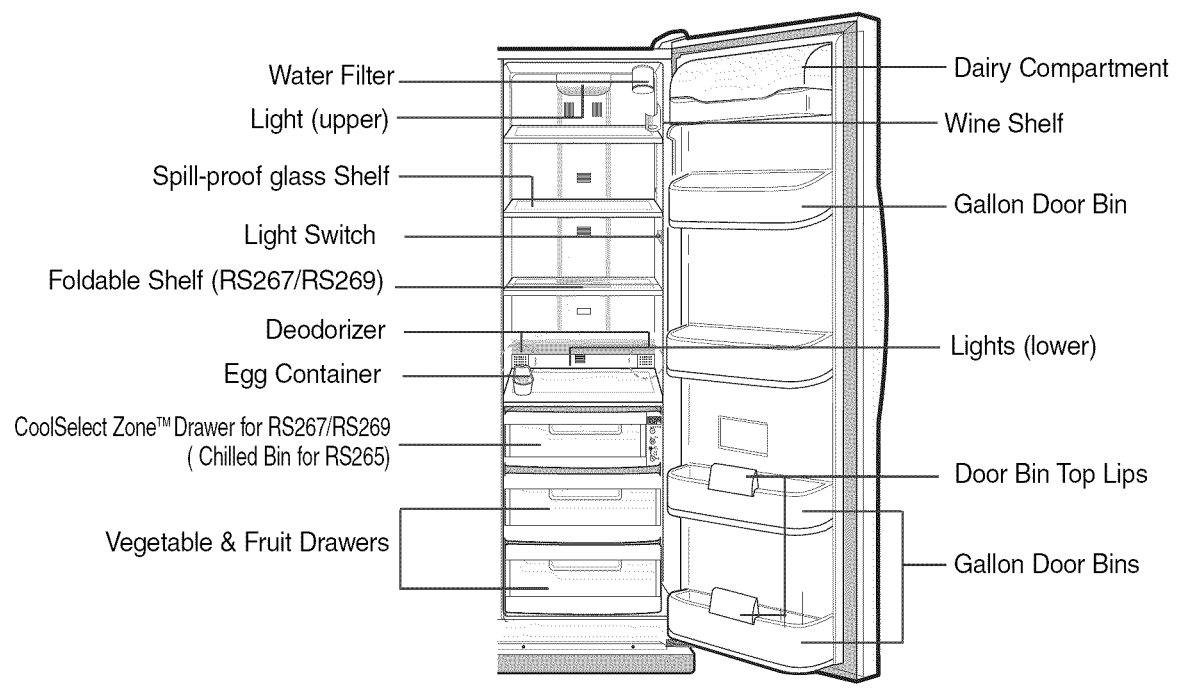

FOOD STORAGE GUIDE

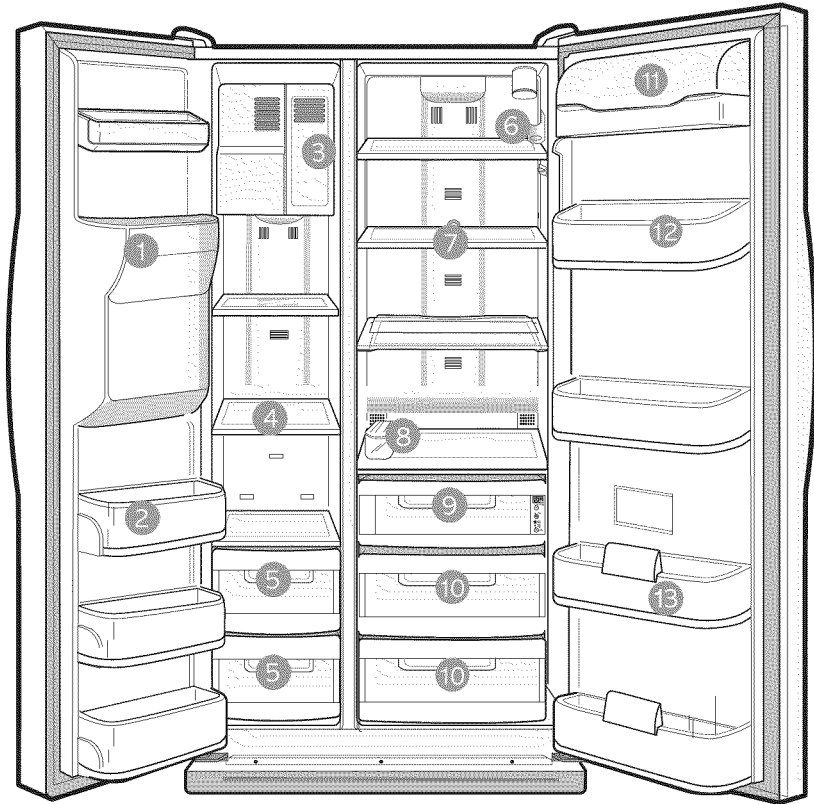

FROZEN FOOD STORAGE IN FREEZER

1 Ice chute



WARNING

Do not put your fingers, hands or any other unsuitable objects in the chute or ice-maker bucket, as this may result in personal injury or material damage.

2 Door Bin (Tilt Pocket)

- Can be used for small packages of frozen food.

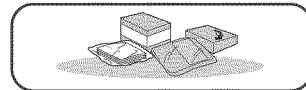

3 Xtra Space™

- Can be used for frozen foods such as pizza, pasta, burritos, and fajitas.
- In order to prevent odor penetration to the ice, stored food should be wrapped securely.

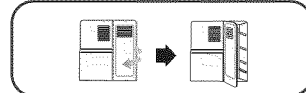

4 Tempered Glass Shelf (Wire Shelf)

- Can be used to store all types of frozen food.



5 Plastics Drawer (Wire Drawer)

- Can be used to store meats and dry foods. Stored food should be wrapped securely using foil or other suitable wrapping materials or containers.

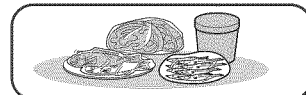

FOOD STORAGE GUIDE

CHILLED FOOD STORAGE IN REFRIGERATOR

- 6** Wine Shelf (RS267/RS269)
• Place your wine bottles on the shelf to maintain their taste.

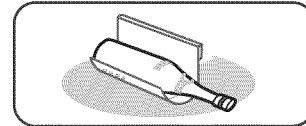

- 7** Tempered Spill Proof Glass Shelf
• Can be used to store all types of chilled food.
• Safe and break resistant.
• Circular marks on the glass surface are a normal phenomenon.

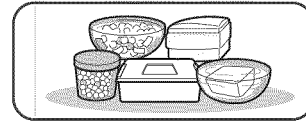

- 8** Egg Container
• Put eggs in the container and place them on the shelf.

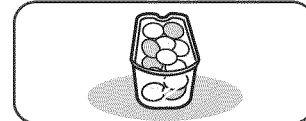

- 9** Chilled Bin or CoolSelect Zone™ Drawer
• Helps to preserve the taste of food and prolongs its freshness. Use to store cheese, meat, poultry, fish or any other foods used quickly.

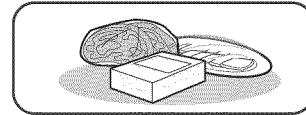

- 10** Fruit & Vegetable Drawer (Upper and Lower)
• Is used to store fruits and vegetables.
• This drawer is airtight. Optimized humidity control design helps to preserve the freshness of the stored vegetables and fruits.



- 11** Dairy Compartment
• Can be used to store butter or margarine.

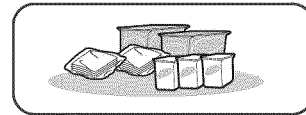

- 12 13** Gallon Door Bins
• Can be used to store foods in small packages, such as milk and yogurt.

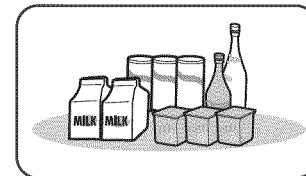

WARNING

- If you have a long vacation planned, empty the refrigerator and turn it off. Wipe excess moisture from the inside and leave the doors open. Otherwise, odor and mold may develop.

CoolSelect Zone™ Drawer GUIDE

“Quick Cool” Button (RS267/RS269)

- You can use the Quick Cool feature with the CoolSelect Zone™.
- “Quick Cool” allows 1–3 canned beverages to cool within 60 min.
- To cancel this option, press the “Quick Cool” button again. CoolSelect Zone™ returns to the previous temperature.
- When “Quick Cool” ends, it returns to the “Cool” temperature setting.

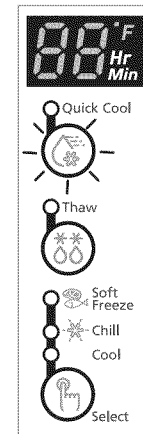

Depending on the beverages, the cool-down time may vary.



When the “Quick Cool” option is selected, remove food stored in the CoolSelect Zone™ Drawer When that you do not want to cool.

“Thaw” Button (RS267/RS269)

- Drips loss and quality deterioration of meats reduces the freshness of foods.
- After “Thaw” is selected, warm and cold air is alternately supplied into the CoolSelect Zone™ Drawer .
- Depending on the weight of meat, thawing time can be selected for 4 hrs, 6 hrs, 10 hrs, and 12 hrs sequentially, keeping the meat partially frozen.
- When “Thaw” ends, the CoolSelect Zone™ display returns to “chill” condition.
- When “Thaw” ends, meats are in a half-frozen state so it is easy to cut them for cooking.
- To cancel this option, press any button except “Thaw”.
- The approximate thawing times of meat and fish are shown below. (Based on 1inch thickness)

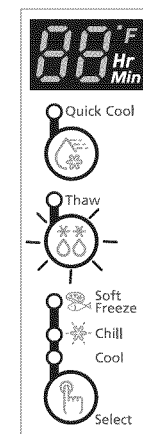

Thaw Time	4 hours	6 hours	10 hours	12 hours
Weight	0.8 lb	1.3 lb	1.7 lb	2.2 lb



Depending on the size and thickness of the meat and fish, the thawing time may vary. The above chart represents the total weight of food in the CoolSelect Zone™ Drawer. Ex) The total thawing time for 1.3 lb frozen beef and 0.8 lb frozen chicken will be 10 hours.



With the “Thaw” option is selected, be sure to remove food stored in the CoolSelect Zone™ Drawer that you do not want to thaw.

CoolSelect Zone™ Drawer GUIDE

“Select” Button (RS267/RS269)

1

Soft Freeze

- When “Soft Freeze” is selected, the temperature on the digital panel displays 23°F(-5°C), regardless of the set temperature of the refrigerator.
- “Soft Freeze” temperature helps keep meat and fish fresh for longer.

2

Chill

- When “Chill” is selected, the temperature of the CoolSelect Zone™ Drawer is kept at 30°F(-1°C), regardless of the set refrigerator temperature.
- “Chill” temperature helps keep meat or fish fresh for longer.

3

Cool

- When “Cool” is selected, the temperature will be the same as the set temperature of the refrigerator. The digital panel shows the same temperature as that of the display panel.
- When using “Cool”, the CoolSelect Zone™ Drawer allows extra refrigerator space.

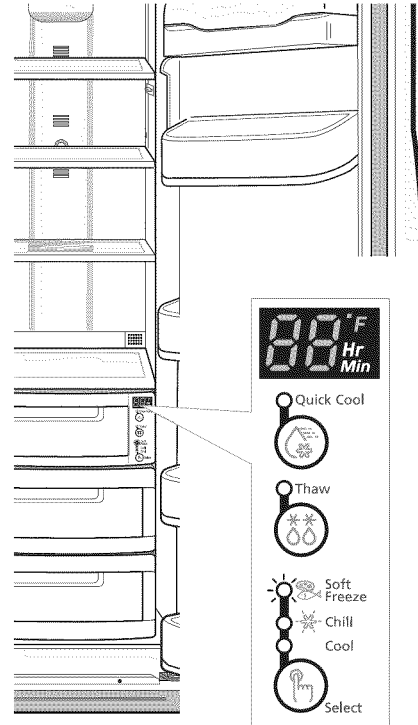

REMOVING THE FREEZER ACCESSORIES

1 Glass Shelf

- Pull the shelf out as far as it goes. Then lift it up and remove it.

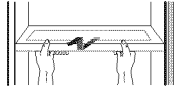

2 Door Bin

- Hold the door bin with both hands and then lift it up.

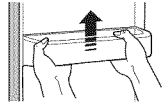

3 Plastic Drawer (Wire Drawer)

- Remove the drawer by pulling it out and slightly lifting it up.

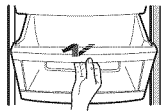

4 Ice Maker Bucket

- Remove the bucket by lifting up and pulling out.

5 Front Leg Cover

- Open the freezer and refrigerator doors, remove three screws and detach the cover.
- To reassemble the front leg cover, put it back to original position and tighten the three screws.

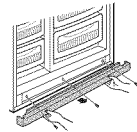

NOTE

- Do not use excessive force when removing the cover. It may cause an injury.

REMOVING THE REFRIGERATOR ACCESSORIES

1 Spill Proof Glass Shelf

- Pull the shelf out as far as it will go. Then lift it up and gently remove it.

2 Vegetable & Fruit Drawer

- Remove the drawer by holding the handle, pulling the drawer out and lifting it up smoothly.
- Remove the optimized humidity control cover by pulling it towards you.

3 Gallon Door Bin

- Hold the bin with both hands and remove it by lifting it up.

4 Wine Shelf

- It is attached to the cabinet wall. To remove the wine shelf, lift it up in the direction of the arrow as shown.
- Simply take the shelf out of the tabs.

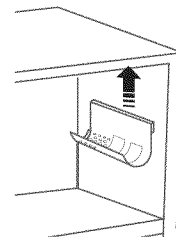

NOTE

- Before removing the freezer and refrigerator accessories, please move the stored foods.

CLEANING THE ACCESSORIES

Interior

- Clean the accessories with a mild detergent, then wipe out with a dry cloth.
- After washing the accessories, make sure that they are dry before using them again.

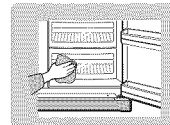

Exterior

- Wipe the digital panel and display panel with a clean cloth.
- The surface of doors, handles and cabinet should be cleaned with a mild detergent and soft cloth, then wipe off the surface with a dry cloth.
 - Do not use Benzene, Thinner or Clorox™ for cleaning
 - Do not spray water directly on the surface of the refrigerator while cleaning.
- The exterior part of the refrigerator should be polished once or twice a year.

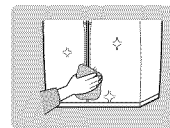

Rear

- Use a vacuum cleaner to remove dust once or twice a year.

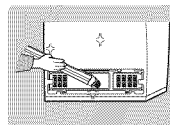

- Do not remove cover, risk of shock.

WARNING

Ice and water dispenser

- Use a damp cloth to clean the ice and water dispenser. Then wipe it out with a dry cloth.
- To keep drainage grid dry, do not touch ice and water dispenser.

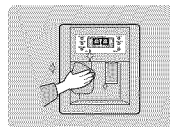

Rubber door seals

- If the rubber door seals are dirty, the door will not close properly, The refrigerator will not be able to function efficiently. Clean the doors with a mild detergent and damp cloth. Then wipe with a dry cloth.

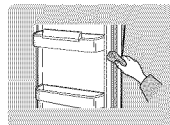

WARNING

- Do not spray the refrigerator with water. It may cause a serious electric shock.
- Do not clean it with benzene, thinner or car detergent. It may cause a fire.

CLEANING THE ACCESSORIES

Twin Deodorizer

- Remove the cover with a flat blade screw driver as shown.
- Take out the cartridge from the cover and soak it in clean and warm water for at least 4 hrs. Completely dry out the cartridge in sunlight for at least 8 hrs in an open area.
- Repeat this process once or twice a year.

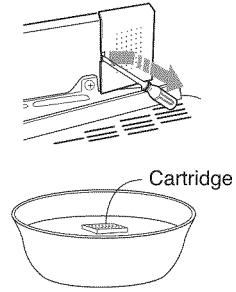

- If cartridge is dried in a confined area, there may be some odor.
- Keep children away from contaminated water.

NOTE

CHANGING THE INTERIOR LIGHT



WARNING

Before changing the interior light, unplug the refrigerator from the power supply. If you have difficulty changing the light, contact your service center.



INTERIOR LIGHT IN THE REFRIGERATOR .

Upper

- 1** Pull out the screw cap ① and remove the screw.
- 2** Pull the lamp cover in the direction of the arrows.
- 3** After changing the bulb, reattach the light cover and screw it in again.

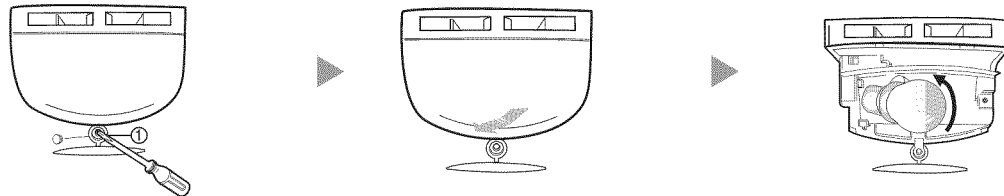

Replacement bulbs for both freezer and fridge are available from your local home improvement or electronics store. Use replacement bulb size E26, maximum 40 watts.

NOTE

Lower

- 1** Pull out the screw cap and remove the screw.
- 2** Take the lamp cover out in the direction of the arrow.
- 3** After changing the bulb, reattach the light cover and screw it again.

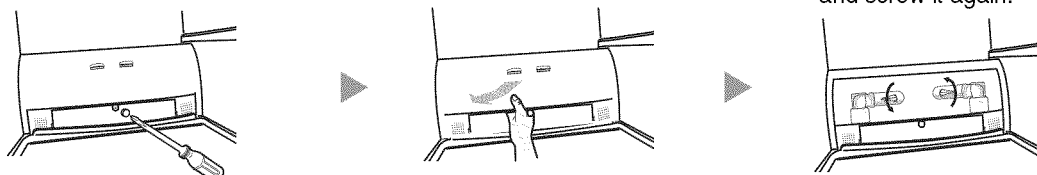

Replacement bulbs for both freezer and fridge are available from your local home improvement or electronics store. Use replacement bulb size E17, maximum 30 watts.

NOTE

CHANGING THE INTERIOR LIGHT



INTERIOR LIGHT IN THE FREEZER.

The freezer light is located in the bottom of the auger motor case.

- 1 Use a screwdriver to remove the light cover (①).
- 2 Change the bulb with a new one (②)
- 3 Reattach the light cover

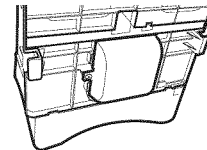
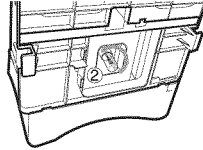
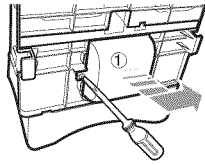

NOTE

Replacement bulbs for both freezer and fridge are available from your local home improvement or electronics store. Use replacement bulb size E17, maximum 30 watts.

WATER FILTER

The water “Filter Indicator” light

- “Filter Indicator” light lets you know when it is time to change your water filter cartridge. The light will change from green to orange. This tells you that it is almost time to change the current cartridge. It is recommended that you replace the cartridge when the light changes to red. (see “Install the water filter” section for more information)
- If you install water filter, throw away the first six glassfulls of water filter, or until water flows clearly to flush impurities in the water supply system.

Using the dispenser without the water filter

- You can not use the water and ice dispenser without a water filter cartridge because the water line blocks at water supply.

Ordering replacement filters

- To order more water filter cartridges, call 1-800-SAMSUNG and ask for accessory Part # DA29-00003A or contact your authorized Samsung dealer.

DOORS

The refrigerator doors have a special door opening and closing feature to make sure that they close all the way and are securely sealed.

When opening the door, it will only open so far. After reaching a certain point, it will remain open.

When the door is partially open, it will close automatically.

The refrigerator should be properly installed & leveled.

INSTALLATION OF THE REFRIGERATOR



Checking the Dimensions of your Entrance Door

Check the dimensions of your entrance door to determine whether the refrigerator can pass through it.

Model		RS265/RS267/RS269	
Capacity (Cu. Ft)		26.1	
Dimension (inch)	Width		36"
	Case Height	without Hinge	69"
		with Hinge	70"
	Depth	with door	35"
without door		30"	



Selecting the Location for the Refrigerator

- Select a location with easy access to the water supply.
- Select a location with enough space for the refrigerator.
- Select a location without direct exposure to sunlight.
- Select a location with level floor or close to it.



NOTE

- Before disassembling the freezer door, the water supply line needs to be disconnected. (If not, the water supply line can be damaged.)
- See "Separating the water supply line from the refrigerator" on the next page.

Allow sufficient space to circulate the air in the internal cooling system.

- When the refrigerator does not have enough space, the internal cooling system may not work correctly.

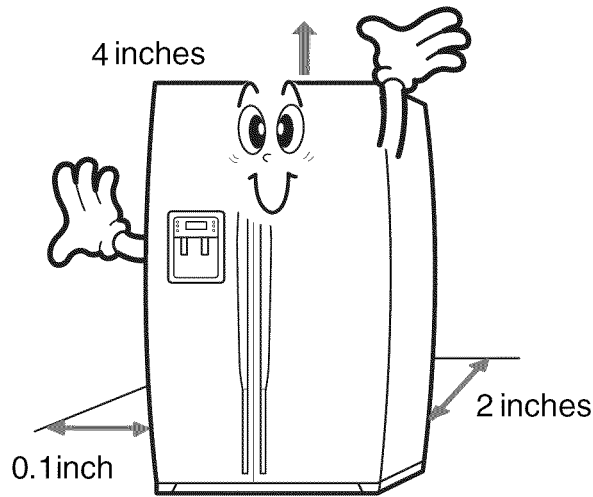

NOTE

- Allow clearance to the right, left, back and top when installing the refrigerator. This has the advantage of reducing power consumption.
- Do not install the refrigerator where the temperature will go below 50°F(10°C).

INSTALLATION INSTRUCTIONS

REMOVING THE REFRIGERATOR DOORS



Removing the Front Leg Cover

Open the freezer and refrigerator doors, and then take off the front leg cover by turning the three screws counter-clockwise.

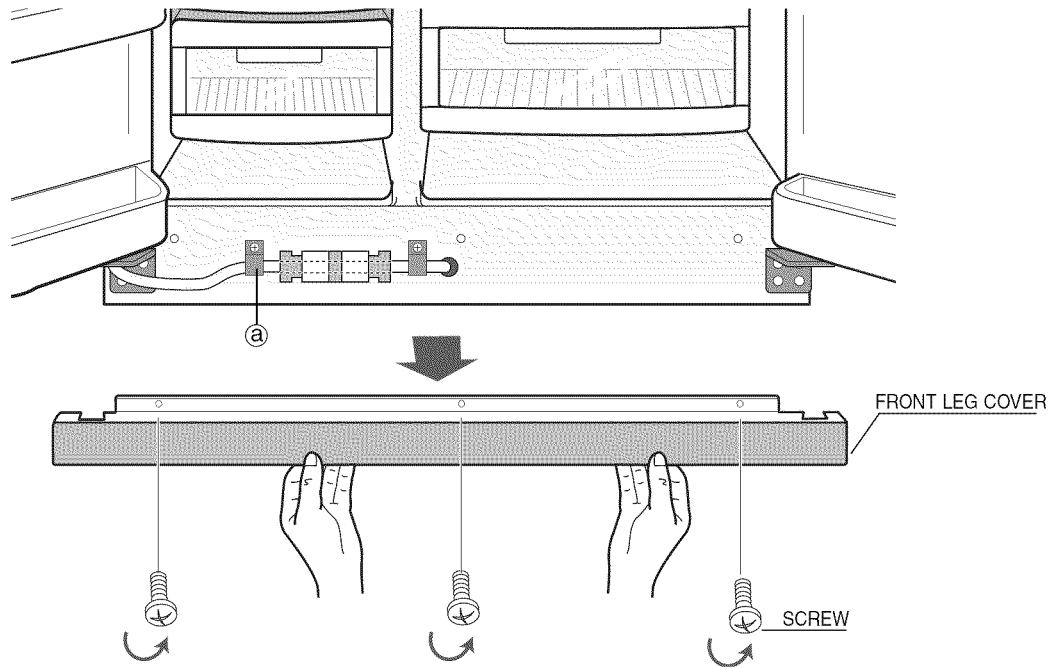

Separating the Water Supply Line from the Refrigerator

- 1) Remove the screw from clamp (a).
- 2) Remove the water tube by pressing the coupler (2) and pulling the water tube (1) away.

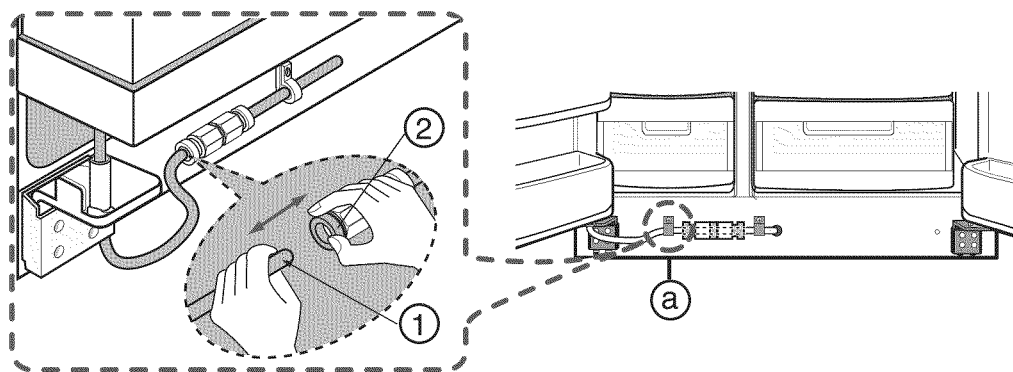

NOTE Do not cut the water tube. Separate it from the coupler.

REMOVING THE REFRIGERATOR DOORS



- Lift the door straight up.
- Be careful not to pinch the water tubing and wire harness on the door.
- Place doors on a protected surface.



Removing the Freezer Door

- 1) With the door closed, remove the upper hinge cover (①) using a screwdriver, and then disconnect the wires (②).

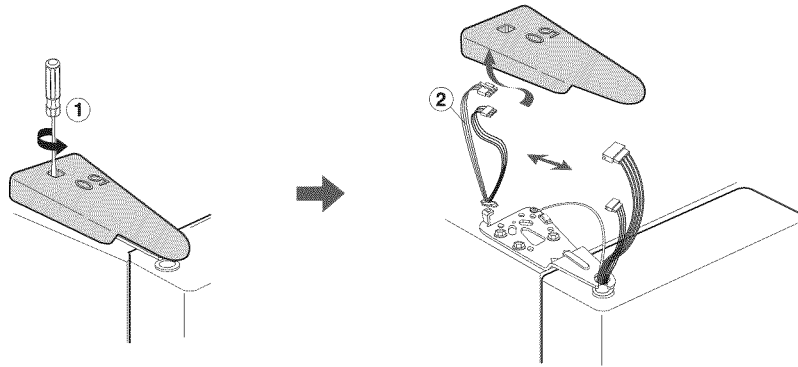

- 2) Remove hinge screws (③) and ground screw (④) counter-clockwise, and take off the upper hinge (⑤) along the arrow (⑥). Be careful when removing the door to ensure that it does not fall on you.

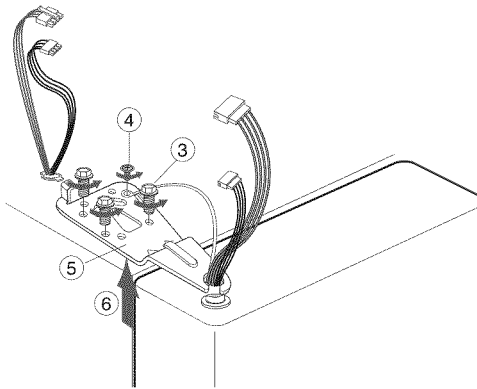

- 3) Remove the door from the lower hinge (⑦) by carefully lifting the door (⑧).

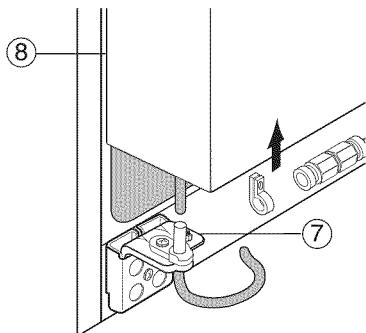

- 4) Remove the lower hinge (⑨) from the bracket lower hinge (⑩) by lifting the lower hinge (⑨) in the direction of the arrow.

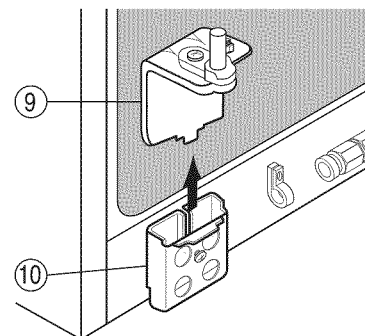

REMOVING THE REFRIGERATOR DOORS



Removing the Refrigerator Door

- 1) With the door closed, remove the upper hinge cover (①) using a screwdriver

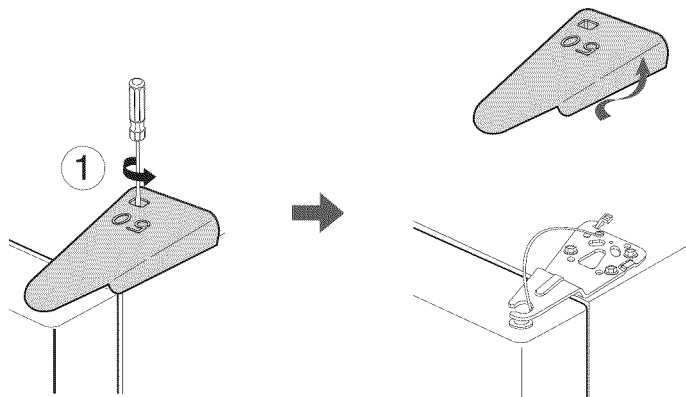

- 2) Remove hinge screws (②) and ground screw (③) counter-clockwise, and take off the upper hinge (④) in the direction of the arrow (⑤). Be careful when removing the door to ensure that it does not fall on you.

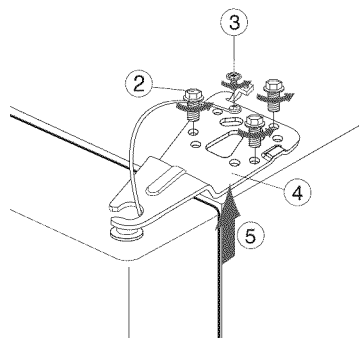

- 3) Remove the door from the lower hinge (⑥) by lifting the door (⑦).

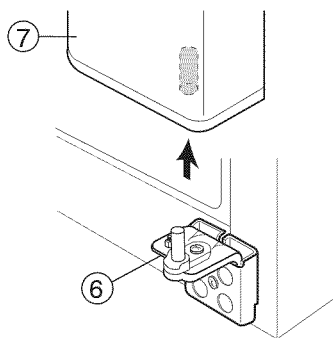

- 4) Remove the lower hinge (⑧) from the bracket (⑨) by lifting the lower hinge (⑧)

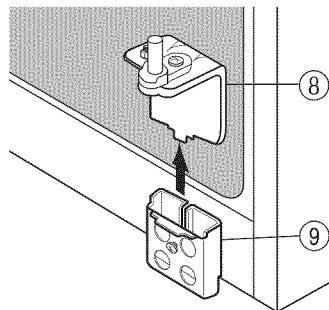

REATTACHING THE REFRIGERATOR DOORS



Reattaching the Freezer Door

- 1) Insert the lower hinge (①) in the bracket lower hinge (②).
- 2) Reattach the freezer door by inserting the hose (③) in the lower side of the door into the hole in the lower hinge (④) and pulling the hose down.

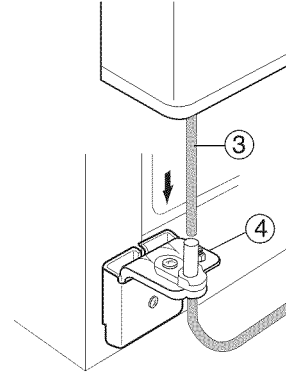
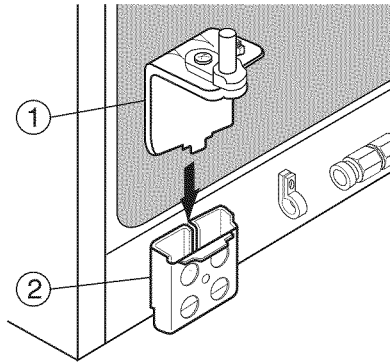

- 3) Insert the upper hinge shaft (⑤) into the hole (⑥). After levelling between the upper hinge hole (⑦) and the hole of the cabinet (⑧), reattach hinge screws (⑨) and ground screw (⑩) in a clockwise direction.

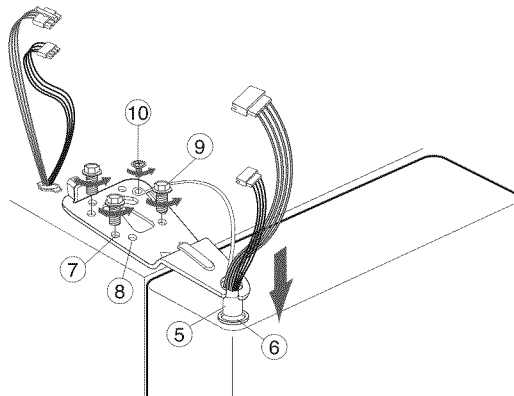

- 4) Connect the wires.

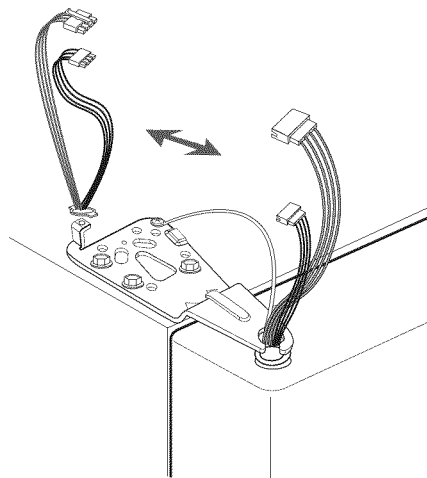

- 5) Put the front part of the upper hinge cover (⑪) on the front part of the upper hinge (⑫) and reattach from the front part of the upper hinge cover first.

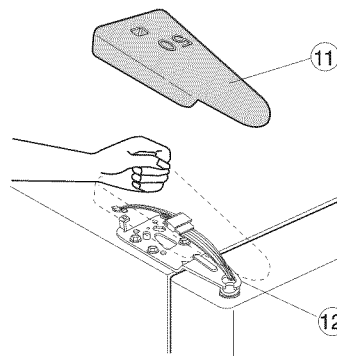

REATTACHING THE REFRIGERATOR DOORS



Reattaching the Refrigerator Door

1) Insert the lower hinge (①) in the bracket lower hinge (②).

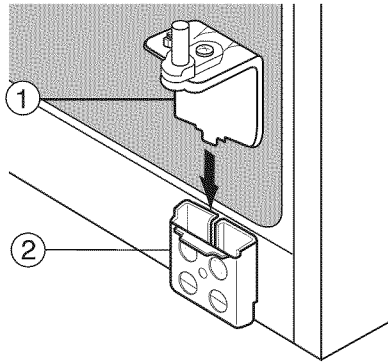

2) Place the hole in the refrigerator door (③) over the lower hinge (④).

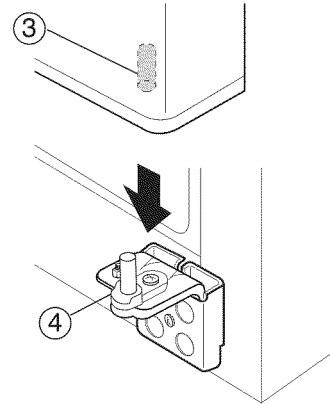

3) Insert the upper hinge shaft (⑤) into the hole (⑥). After levelling between the upper hinge hole (⑦) and the hole of the cabinet (⑧), reattach hinge screws (⑨) and ground screw (⑩) in the clockwise direction.

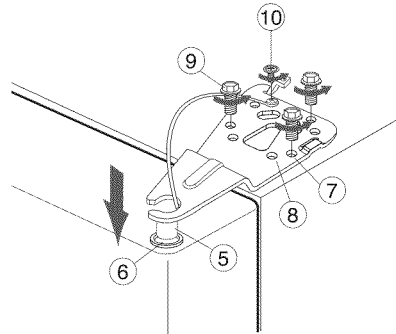

4) Connect the wires.

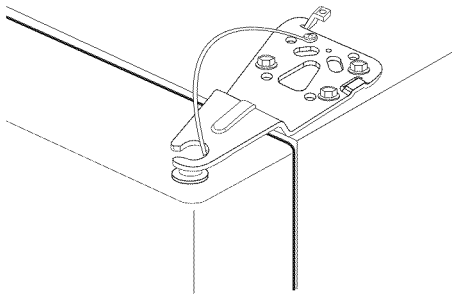

5) Put the front part of the upper hinge cover (⑪) on the front part of the upper hinge (⑫) and reattach it from the front part of the upper hinge cover first.

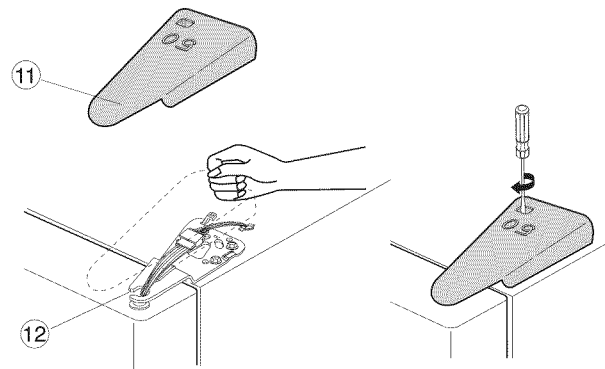

REATTACHING THE REFRIGERATOR DOORS



Reattaching the Water Supply Line

- 1) While pressing the front face of coupler (2), insert the water line (1) in the coupler.
- 2) Tighten the screw on the clamp (a).

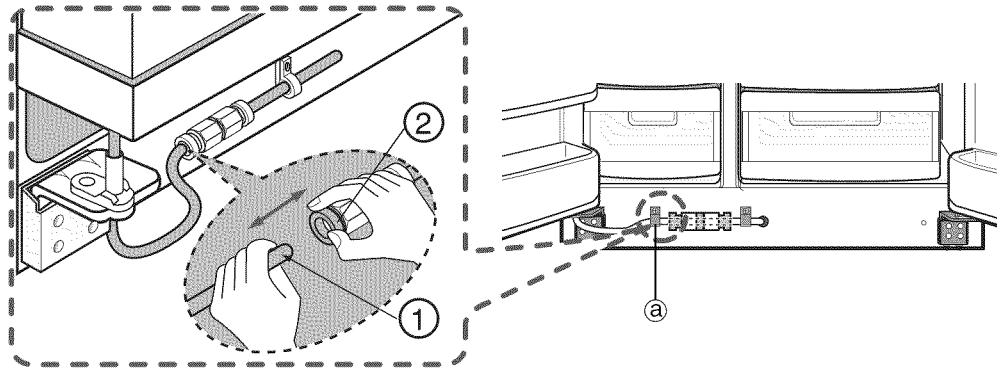

Reattaching the Front Leg Cover

Put on the front leg cover by turning the three screws clockwise, as shown in the figure.



NOTE Before attaching check water connector, be sure to check for leakage.

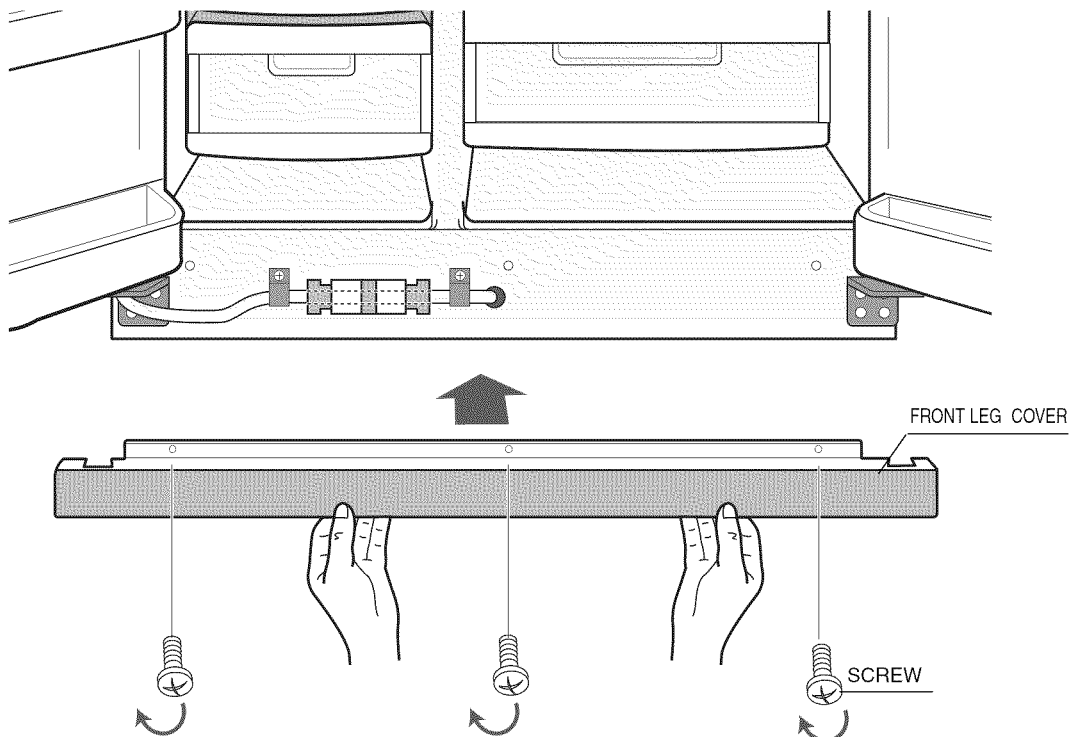

LEVELING REFRIGERATOR



Make sure the refrigerator is level before adjusting its doors.

The doors will be uneven if the refrigerator is not level.



The front of refrigerator is adjustable.

NOTE

Case 1) Freezer door is lower than that of the refrigerator

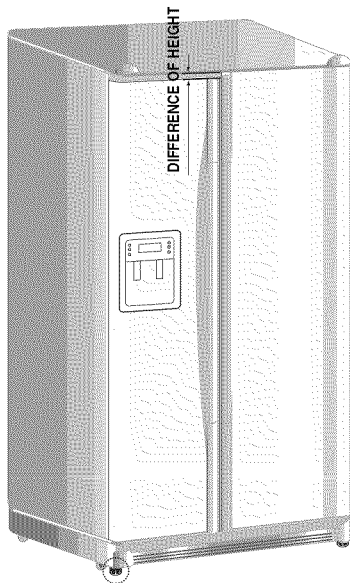

Insert a flat-blade screwdriver (-) (①) into a slot of the control lever (②), turn it clockwise and level the refrigerator.

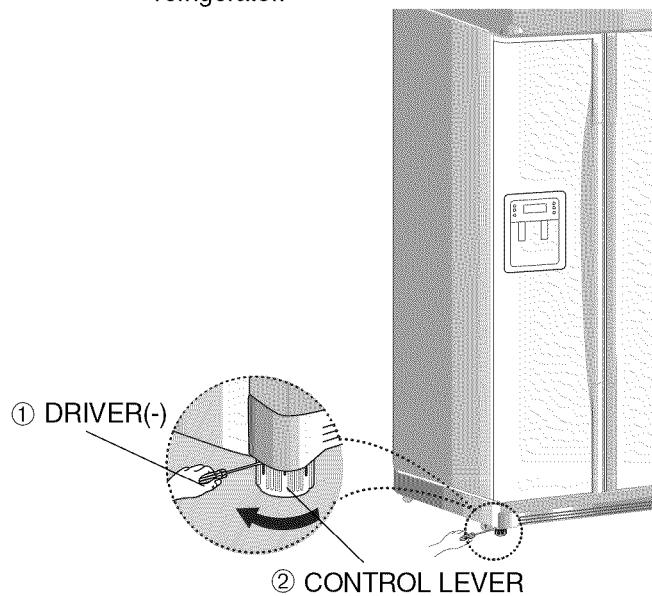

Case 2) Freezer door is higher than that of the refrigerator

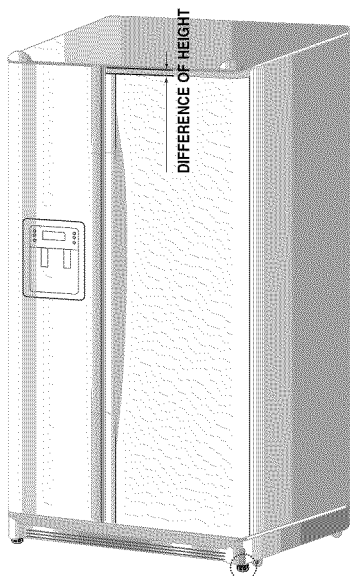

Insert a flat-blade screwdriver (-) (①) into a slot of the control lever (②), turn it clockwise and level the refrigerator.

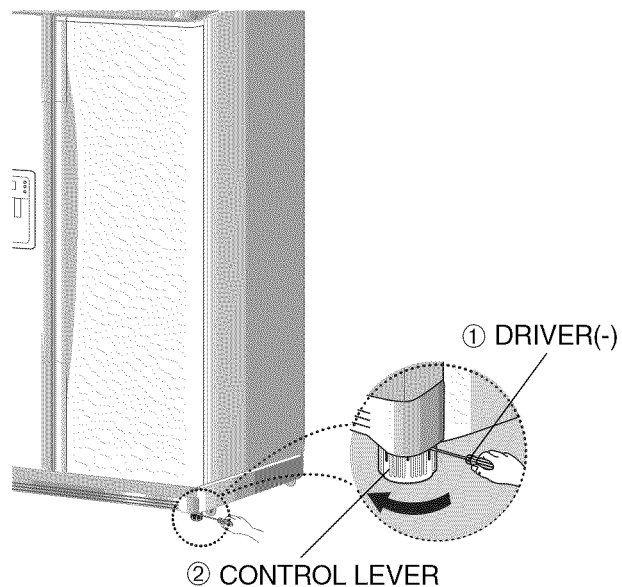

Do not make small adjustments with the control lever, Please refer to the next page.

NOTE

ADJUSTING THE CLEARANCE BETWEEN THE DOORS

 Adjust Leveling first.
NOTE

 **Making small adjustments between doors.**

If the door of the freezer is lower than that of the refrigerator.

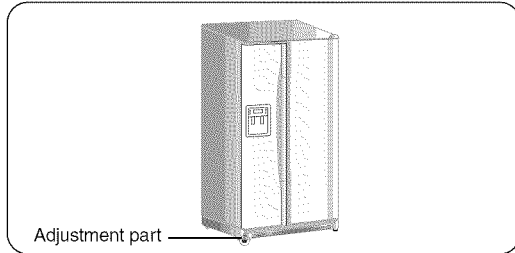

If the door of freezer is higher than that of the refrigerator.

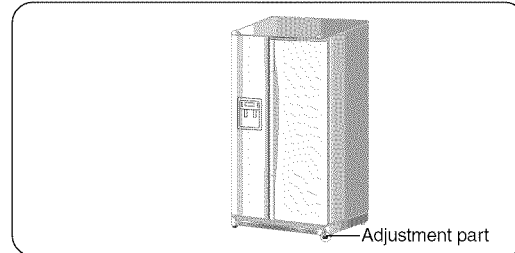

Please open the doors and adjust them as follows:

- 1) Release the nut (①) on the lower hinge until it reaches the upper end of the bolt (②).

 **NOTE** When you release the nut (①), use enclosed hex wrench (③) to turn the bolt (②) in a slightly counterclockwise direction. This will enable you to loosen the nut (①) with your fingers.

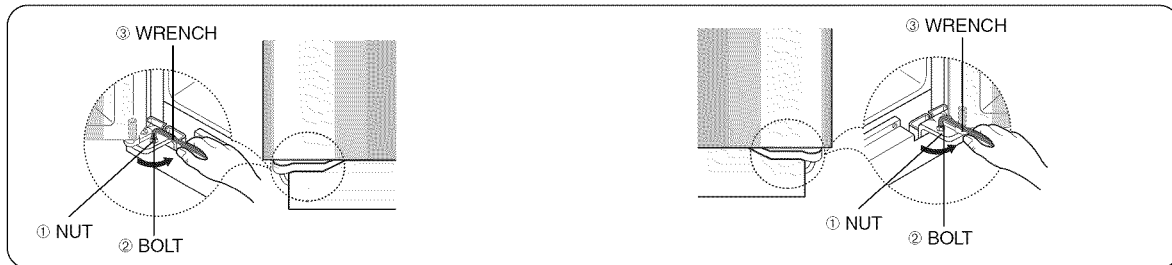

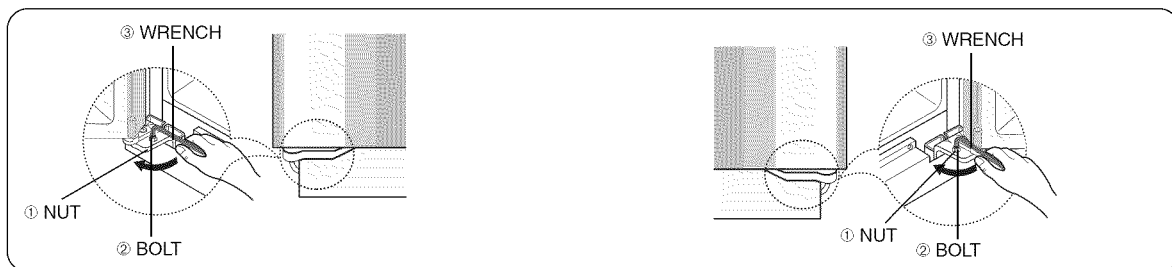

- 2) Please adjust the height difference between the doors by turning the bolt (②) clockwise (↷) or counter clockwise (↶).

 **NOTE** When you turn clockwise (↷), the door goes up.

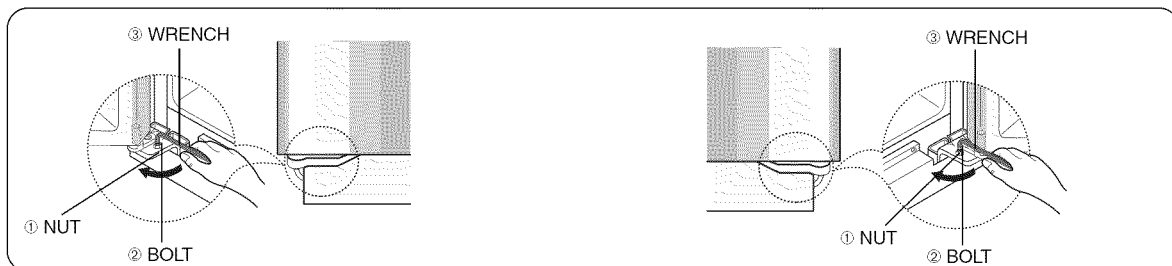

- 3) After adjusting the doors, turn the nut in clockwise (↷) until it reaches the lower end of the bolt, then tighten the bolt again with the wrench (③) to fix the nut (①).



 **NOTE** If you do not fix the nut (①) firmly, the bolt (②) may be released.

CHECKING THE WATER DISPENSER LINE

- 1) In order to operate the ice maker properly, water pressure of 20 ~125 psi is required.
In this range a 170 cc (5.74 ounces) paper cup can be filled in 10 secs.
- 2) The water filter removes particles. It does not sterilize or destroy any micro-organisms.
- 3) If the refrigerator is installed in an area with low water pressure (below 20psi), you should install a booster pump to compensate.
- 4) Ensure the water storage tank inside the refrigerator is properly filled initially. Push the water dispenser lever until the water runs from the outlet.



Water line installation kit is available at extra cost from your dealer. The refrigerator manufacturer recommends using a water supply kit containing copper tubing.



Connecting to water supply line

- Shut off the main water supply line and turn the Ice maker to the off position.
- Locate the nearest cold drinking water line.
- Follow the instructions in the ice maker installation kit.
- After connecting the water supply with water filter, turn on water supply and flush 4 or more gallons into a bucket to clear the water filter

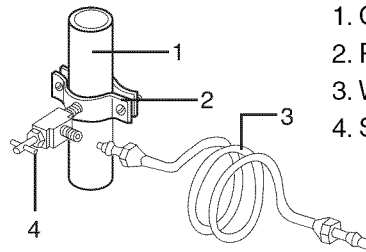

1. Cold Water line
2. Pipe Clamp.
3. Water Line Installation Kit
4. Shut Off Valve

INSTALLATION OF THE WATER DISPENSER LINE



Connect the water line to the refrigerator.

- 1) Slip the compression nut through the provided plastic tubing.
- 2) Tighten the compression nut onto 1/4" compression fitting.



NOTE Do not overtighten the compression nut.

- Using Copper Tubing
 - Slip the compression nut and ferrule on copper tubing as shown.
 - Using Plastic Tubing
 - Insert the molded end of the plastic tubing into the compression fitting.
- 3) Tighten the compression nut onto the compression fitting.
 - 4) Turn water on and check for any leakage.

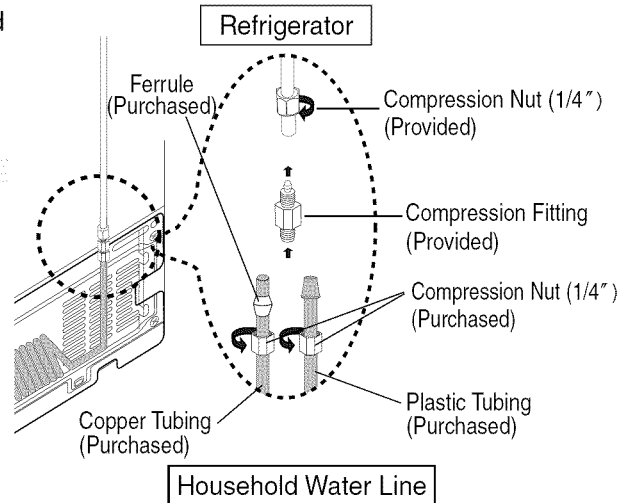

Water line must be connected to drinkable water only.
NOTE Cut off 1/4 inch of the provided plastic tubing squarely to prevent leaks when reconnect.



Install the water filter.

- 1) As shown, the fixed cap separates from the refrigerator by rotating it counterclockwise. Remove the water filter from the box and put a month indicator stick on the filter as shown.



Keep the cap(A) in a safe place for recapping, when you don't use the filter.

- 2) If the water filter was installed in March, put on the "SEP" sticker.
- 3) Remove the protective cap then position and insert the filter as shown.
- 4) Slowly turn the water filter clockwise 90° to align the indication mark on the cover, locking the filter in position. Do not overtighten.

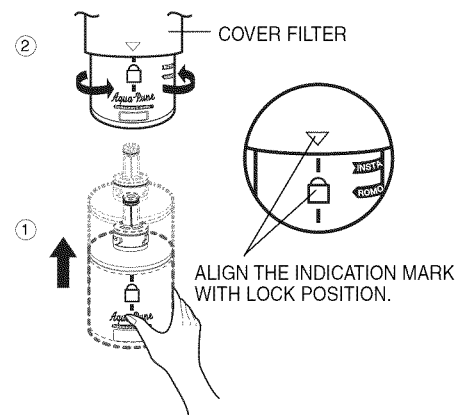
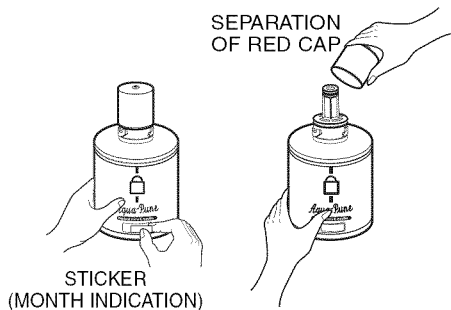
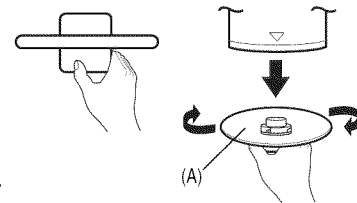

Please check that the indication line aligns with the lock position.

INSTALLATION OF THE WATER DISPENSER LINE



Remove any residual matter inside the water supply line after installing filter.

- 1) Turn on the main water supply & shut-off the valve of the water supply line.
- 2) Run water through the dispenser until the water runs clear (6~7 minutes). This will clean the water supply system and clear air from the lines.
- 3) Additional flushing may be required in some households.
- 4) Open the refrigerator door and check if water leaks around the water filter.

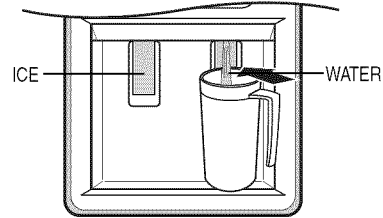

- NOTE**
- A newly-installed water filter cartridge may cause water to briefly spurt from the dispenser.
 - Before reinstalling the water filter, remove the wine shelf (RS267/RS269).



Check the amount of water supplied to the ice tray.

- 1) Lift up (①) and pull out (②) the ice maker bucket in the freezer.

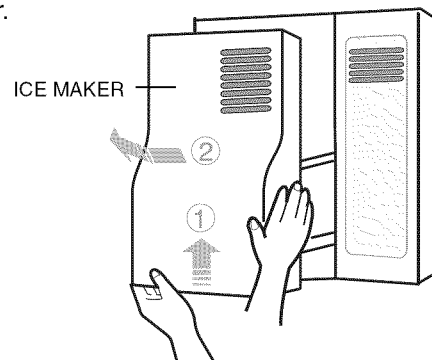

- 2) When you press the test button, the ice cube container is filled with water from the water supply tap. Check the amount of water (see the illustration below).
If the water level is too low, the ice cubes will be small. This is not a problem with the ice maker but of the water pressure in the pipe, and occurs frequently. When this problem occurs, contact a service person to check the amount of water supplied.

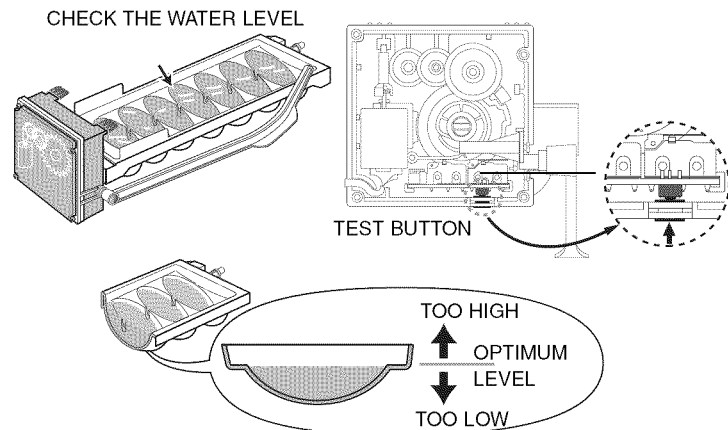

TROUBLESHOOTING

The refrigerator does not work at all or it does not chill sufficiently

- Check that the power plug is properly connected.
- Is the temperature control on the display panel set to the correct temperature? Try setting it to a lower temperature.
- Is the refrigerator in direct sunlight or located near a heat source?
- Is the back of the refrigerator too close to the wall?

The food in the refrigerator is frozen

- Is the temperature control on the display panel set to the correct temperature? Try setting it to a warmer temperature.
- Is the temperature in the room too low?
- Did you store food with a high water content in the coldest part of the refrigerator?

You hear unusual noise or sounds

- Check that the floor is leveled and stable.
- Is the back of the refrigerator too close to the wall?
- Was anything dropped behind or under the refrigerator?
- A “ticking” sound may be heard from inside the refrigerator, this is normal. This occurs because various accessories are contracted or expanded.

The front corners and sides of the cabinet are hot; condensation occurs.

- Anti-condensators are installed in the front corners of the refrigerator to prevent condensation.
- Condensation can occur when you leave the door open for a long time.

Ice is not dispensed

- Did you stop the ice making function?
- Is there any ice in the ice storage unit?
- Is the water line connected and the shut-off valve open?
- Is the freezer temperature too warm? (Set the temperature lower)
- Did you wait for 12 hours after installation of the water supply line before making ice?

You can hear water bubbling in the refrigerator

- The bubbling comes from the refrigerant circulating in the refrigerator and is normal.

There is a bad smell in the refrigerator

- Wrap strong smelling food so that it is airtight. Throw away any rotten food.

Frost forms on the walls of the freezer

- Is the air vent blocked?
- Allow sufficient space between the foods stored for efficient air circulation.
- Is the door closed properly?

No water is supplied

- Is the water line connected and the shut-off valve open?
- Is the water supply line crushed?
- Is the water tank frozen because the refrigerator temperature is too low? Select a warmer setting on the display panel.

SAMSUNG REFRIGERATOR (18 Cubic Feet and Larger Capacity)

LIMITED WARRANTY TO ORIGINAL PURCHASER

This SAMSUNG brand product, as supplied and distributed by Samsung Electronics America, Inc. (SAMSUNG) and delivered new, in the original carton to the original consumer purchaser, is warranted by SAMSUNG against manufacturing defects in materials and workmanship for a limited warranty period of:

One (1) Year Parts and Labor on Refrigerator
Five (5) Years Parts and Labor on Sealed Refrigeration System Only*
(*Compressor, evaporator, condenser, drier, connecting tubing)

This limited warranty begins on the original date of purchase, and is valid only on products purchased and used in the United States. To receive warranty service, the purchaser must contact SAMSUNG for problem determination and service procedures. Warranty service can only be performed by a SAMSUNG authorized service center. The original dated bill of sale must be presented upon request as proof of purchase to SAMSUNG or SAMSUNG's authorized service center.

SAMSUNG will repair or replace any part found to be defective, at our option and at no charge as stipulated herein, with new or reconditioned parts during the limited warranty period specified above. All replaced parts and products become the property of SAMSUNG and must be returned to SAMSUNG. Replacement parts and products assume the remaining original warranty, or ninety (90) days, whichever is longer.

In-home service will be provided during the warranty labor period subject to availability within the contiguous United States. In-home service is not available in all areas. To receive in-home service, the product must be unobstructed and accessible from floor level to service personnel. If during in-home service repair cannot be completed, it may be necessary to remove, repair and return the product. If in-home service is unavailable, SAMSUNG may elect, at our option, to provide for transportation of our choice to and from a SAMSUNG authorized service center. Otherwise, transportation to and from the SAMSUNG authorized service center is the responsibility of the purchaser.

This limited warranty covers manufacturing defects in materials and workmanship encountered in normal, noncommercial use of this product, and shall not apply to the following, including, but not limited to: damage which occurs in shipment; delivery and installation; applications and uses for which this product was not intended; altered product or serial numbers; cosmetic damage or exterior finish; accidents, abuse, neglect, fire, water, lightning or other acts of nature; use of products, equipment, systems, utilities, services, parts, supplies, accessories, applications, installations, repairs, external plumbing and leaks, external wiring, circuit breakers, fuses or connectors not supplied and authorized by SAMSUNG, or which damage this product or result in service problems; incorrect electrical line voltage, fluctuations and surges; customer adjustments and failure to follow operating instructions, cleaning, maintenance and environmental instructions that are covered and prescribed in the instruction book; loss of food due to spoilage; consumable items including filters and light bulbs.

THERE ARE NO EXPRESS WARRANTIES OTHER THAN THOSE LISTED AND DESCRIBED ABOVE, AND NO WARRANTIES WHETHER EXPRESS OR IMPLIED, INCLUDING, BUT NOT LIMITED TO, ANY IMPLIED WARRANTIES OF MERCHANTABILITY OR FITNESS FOR A PARTICULAR PURPOSE, SHALL APPLY AFTER THE EXPRESS WARRANTY PERIODS STATED ABOVE, AND NO OTHER EXPRESS WARRANTY OR GUARANTY GIVEN BY ANY PERSON, FIRM OR CORPORATION WITH RESPECT TO THIS PRODUCT SHALL BE BINDING ON SAMSUNG. SAMSUNG SHALL NOT BE LIABLE FOR LOSS OF REVENUE OR PROFITS, FAILURE TO REALIZE SAVINGS OR OTHER BENEFITS, OR ANY OTHER SPECIAL, INCIDENTAL OR CONSEQUENTIAL DAMAGES CAUSED BY THE USE, MISUSE OR INABILITY TO USE THIS PRODUCT, REGARDLESS OF THE LEGAL THEORY ON WHICH THE CLAIM IS BASED, AND EVEN IF SAMSUNG HAS BEEN ADVISED OF THE POSSIBILITY OF SUCH DAMAGES. NOR SHALL RECOVERY OF ANY KIND AGAINST SAMSUNG BE GREATER IN AMOUNT THAN THE PURCHASE PRICE OF THE PRODUCT SOLD BY SAMSUNG AND CAUSING THE ALLEGED DAMAGE. WITHOUT LIMITING THE FOREGOING, PURCHASER ASSUMES ALL RISK AND LIABILITY FOR LOSS, DAMAGE OR INJURY TO PURCHASER AND PURCHASER'S PROPERTY AND TO OTHERS AND THEIR PROPERTY ARISING OUT OF THE USE, MISUSE OR INABILITY TO USE THIS PRODUCT SOLD BY SAMSUNG NOT CAUSED DIRECTLY BY THE NEGLIGENCE OF SAMSUNG. THIS LIMITED WARRANTY SHALL NOT EXTEND TO ANYONE OTHER THAN THE ORIGINAL PURCHASER OF THIS PRODUCT, IS NONTRANSFERABLE AND STATES YOUR EXCLUSIVE REMEDY.

Some states do not allow limitations on how long an implied warranty lasts, or the exclusion or limitation of incidental or consequential damages, so the above limitations or exclusions may not apply to you. This warranty gives you specific legal rights, and you may also have other rights, which vary from state to state.

To obtain warranty service, please contact SAMSUNG at:

SAMSUNG CUSTOMER CARE CENTER
Samsung Electronics America, Inc.
105 Challenger Road Ridgefield Park NJ 07660-0511
1-800-SAMSUNG (1-800-726-7864) and www.SAMSUNG.com

061002

MEMO

SAMSUNG

If you have any questions or comments relating to Samsung products,
please contact the SAMSUNG customer care centre.

Samsung Electronics America, Inc.

105 Challenger Road Ridgefield Park, NJ 07660-0511

1-800-SAMSUNG (1-800-726-7864)

www.samsung.com

