

*INSTALLER: LEAVE THESE INSTRUCTIONS WITH THE APPLIANCE*

# **Electric Installation Manual**

## **30" WIDE FREE-STANDING RANGE**

**PLEASE KEEP THIS MANUAL FOR FUTURE REFERENCE**

*THE MANUAL IS INTENDED TO ASSIST IN THE INITIAL INSTALLATION AND ADJUSTMENTS OF THE RANGE.*

### **SPECIAL WARNING**

**ONLY QUALIFIED PERSONNEL SHOULD INSTALL OR SERVICE THIS RANGE.**

**READ "SAFETY INSTRUCTIONS" IN USE & CARE BOOK BEFORE USING RANGE.**

**IMPROPER INSTALLATION, ADJUSTMENT, ALTERATION, SERVICE, MAINTENANCE OR USE OF RANGE CAN RESULT IN SERIOUS INJURY OR PROPERTY DAMAGE.**

### **CLEARANCE DIMENSIONS**

For complete information in regard to installation of range, see figures 1 and 2 on page 2. For SAFETY CONSIDERATIONS, do not install a range in any combustible cabinetry which is not in accord with the installation clearances shown in figure 1 on page 2.

**CAUTION:** SOME CABINETS AND BUILDING MATERIALS ARE NOT DESIGNED TO WITHSTAND THE HEAT PRODUCED BY THE NORMAL SAFE OPERATION OF A LISTED APPLIANCE. DISCOLORATION OR DAMAGE, SUCH AS DELAMINATION, MAY OCCUR.

**YOUR RANGE MAY NOT BE EQUIPPED WITH SOME OF THE FEATURES REFERRED TO IN THIS MANUAL.**

## Precautions To Avoid Possible Exposure To Excessive Microwave Energy

- A. Do not attempt to operate this oven with the door open since open-door operation can result in harmful exposure to microwave energy. It is important not to defeat or tamper with the safety interlocks.
- B. Do not place any object between the oven front face and the door or allow soil or cleaner residue to accumulate on sealing surfaces.
- C. Do not operate the oven if it is damaged. It is particularly important that the oven door close properly and that there is no damage to the: (1) Door (bent), (2) hinges and latches (broken or loosened), (3) door seals and sealing surfaces.
- D. The oven should not be adjusted or repaired by anyone except properly qualified service personnel.

## Installation Drawings

**IMPORTANT – PLEASE KEEP FOR THE USE OF THE LOCAL ELECTRICAL INSPECTOR.**

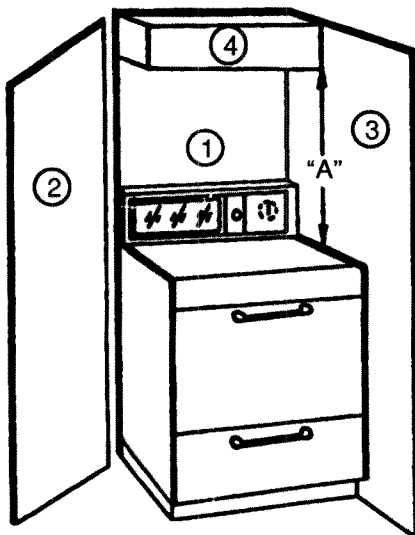


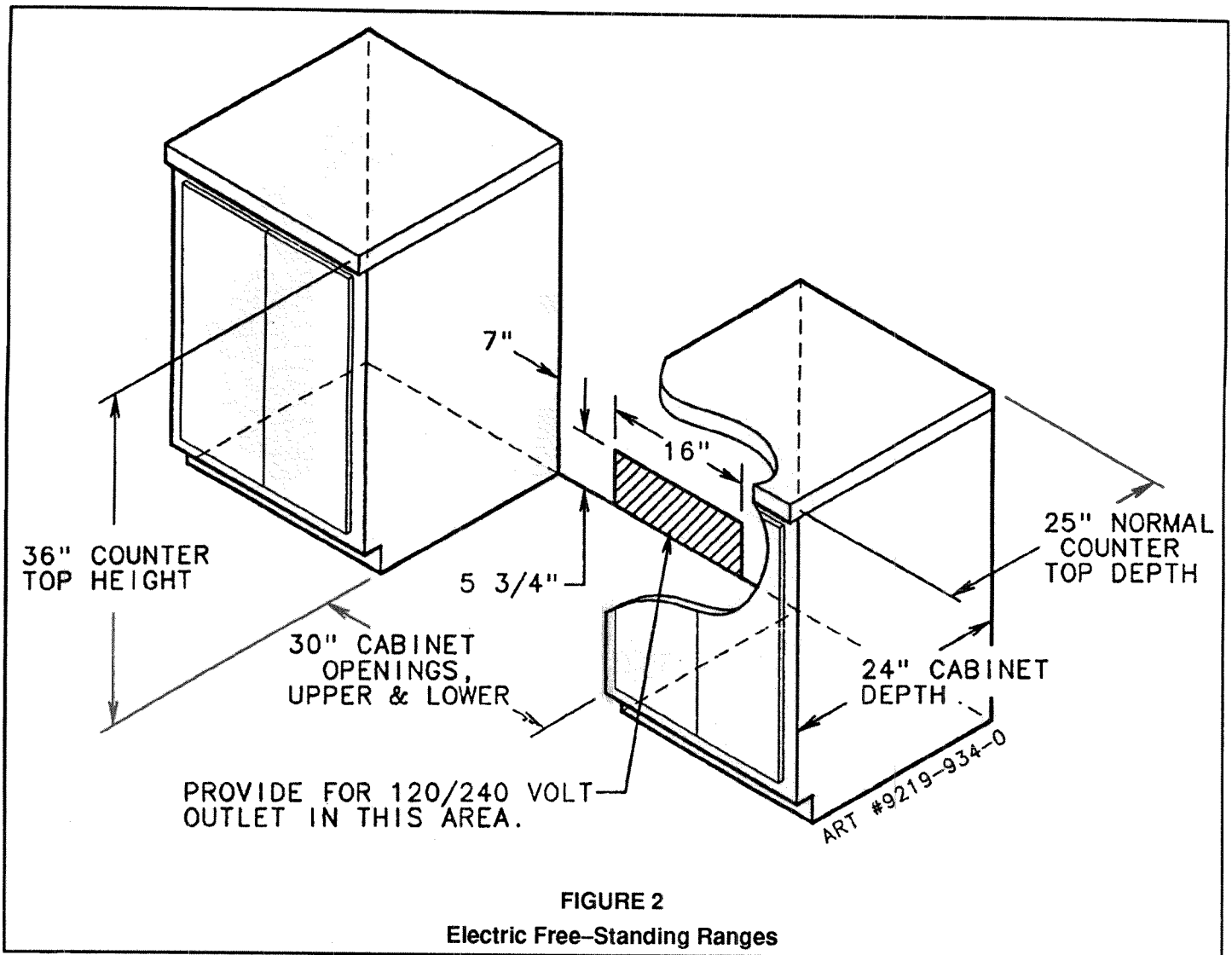
FIGURE 1

"A" = 30 inches minimum clearance between the top of the cooking surface and the bottom of an unprotected wood or metal cabinet, or "A" = 24 inches minimum when bottom of wood or metal cabinet is protected by not less than 1/4-inch thick flame-retardant millboard covered with not less than No. 28 MSG sheet steel, 0.015-inch thick stainless steel, 0.024-inch thick aluminum, or 0.020-inch thick copper.

To eliminate the risk of burns or fire by reaching over heated surface units, cabinet storage space located above the surface units should be avoided. If cabinet storage is to be provided, the risk can be reduced by installing a range hood that projects horizontally a minimum of 5 inches beyond the bottom of the cabinets.

- 1, 2, 3 – COMBUSTIBLE BUILDING WALLS.
- 4 – COMBUSTIBLE WALL CABINET.

A FREE-STANDING RANGE MAY BE INSTALLED ADJACENT TO (0" FROM) COMBUSTIBLE WALLS 1, 2 & 3.



## Mobile Homes

The installation of a range designed for mobile home installation must conform with the Manufactured Home Construction and Safety Standard, Title 24 CFR, Part 3280 (formerly the Federal Standard for Mobile Home Construction and Safety, Title 24 HUD, Part 280) or, when such standard is not applicable, the Standard for Manufactured Home Installations 1982 (Manufactured Home Sites, Communities and Set-Ups), ANSI A225.1-1984, or with local codes.

## Locating The Range

Place range where it will be well lighted. Do not set range over holes in the floor or other locations where it may be subject to strong drafts. Any opening in the wall behind the range and in the floor under the range should always be sealed. Make sure the flow of combustion or ventilation air is not obstructed.

# Anti-tip Device Installation Instructions

**WARNING:** A risk of range tip-over exists if the appliance is not installed in accordance with the installation instructions provided. The proper use of this device minimizes the risk of TIP-OVER. In using this device the consumer must still observe the safety precautions as stated in the USE and CARE MANUAL and avoid using the oven door and/or lower drawer as a step stool.

Installation instructions are provided for wood and cement installation in either floor or wall. Any other type of construction may require special installation techniques as deemed necessary to provide adequate fastening of the ANTI-TIP bracket to the floor or wall. The bracket may be installed to engage the left or right rear leveling leg.

## STEP 1 – Locating The Bracket (see figure 3)

### Installations with flush mount wall outlet

- Mark the floor or wall where either the right or left rear “EDGE” of the range is to be located.
- Place the BRACKET 15/16” from the marked “EDGE” toward center of opening and against the back wall as shown in figure 3.
- Use the bracket as a template and mark the required holes, as shown in figure 3, for the type of construction you will be using.

### Installations with alternate outlet locations (see figures 4 through 6.)

- Mark the floor or wall where either right or left rear “EDGE” of the range is to be located.
- Place the bracket 15/16” from the marked “EDGE” toward the center of opening and against the spacer as shown in figures 4 through 6, as applicable. (See figures 4 through 6 for information on appropriate spacer sizes. See figure 8 for information on securing of spacer.)
- Use the bracket as a template and mark the required holes, as shown in figure 4 through 6, for the type of construction you will be using.

## STEP 2 – Anti-Tip Bracket Installation

### A. Wood Construction:

- Floor: Locate the center of the two holes identified in figures 3 through 6, as applicable, as “holes for floor.” Drill a 1/8” pilot hole in the center of each hole (a nail or awl may be used if a drill is not available.) Secure the ANTI-TIP bracket to the floor with the two screws provided. Proceed to STEP 3.
- Wall: Locate the center of the two holes identified in figures 3 through 6, as applicable, as “holes for wall.” Drill an angled 1/8” pilot hole in the center of each hole as shown in figure 7 or 8 (a nail or awl may be used if a drill is not available.) Secure the ANTI-TIP bracket to the wall with the two screws provided as shown in figure 7 or 8. Proceed to STEP 3.

### B. Cement or Concrete Construction:

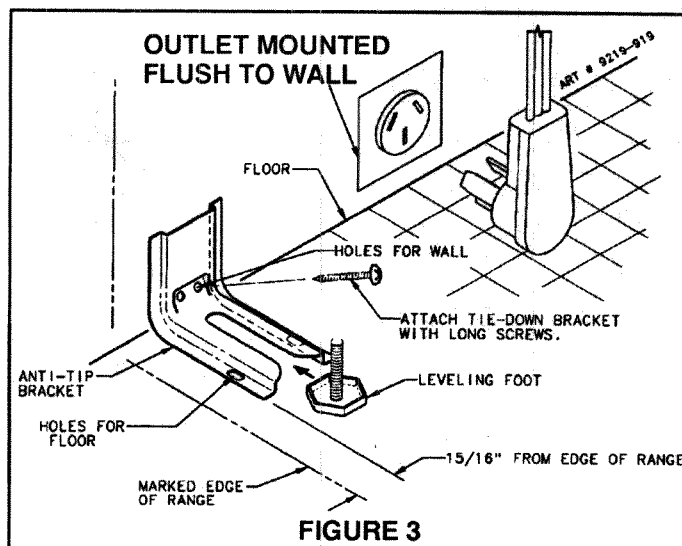
- Suitable screws for concrete construction can be obtained at a hardware store. Drill the required size hole for the screws obtained into the concrete at the center of the holes identified in figures 3 through 6, as applicable, as “holes for floor.” Secure the ANTI-TIP bracket to the floor. Proceed to STEP 3.

## STEP 3 – Range Installation

- Complete the installation of the range per the installation instructions provided with the product.
- Align the range to its designated location and slide it back into position. Make sure that the leveling foot is fully inserted into and secured by the ANTI-TIP bracket. Note: A minimum clearance of 1/4” is required between the range and the leveling foot that will engage the ANTI-TIP bracket, see figure 7 or 8.

**CAUTION:** Damage to the range may occur if range is moved or lifted by grasping the main top or backguard.

- All free-standing ranges with a glass top have a non-lift-up top. Coil tops are lift-up.
- For SAFETY CONSIDERATIONS as well as optimum performance adjust the range so that it is level. This may be checked by placing a spirit level or a large pan of water on the cooktop or the oven rack. If an adjustment is required pull the range forward, tip the range and rotate the leveling feet as required.
- To check the range for proper installation of the anti-tip bracket: Use a flashlight and look underneath the bottom of the range to see that one of the rear leveling legs is engaged in the bracket slot.
- Proceed with the remainder of the installation instructions provided with the range.



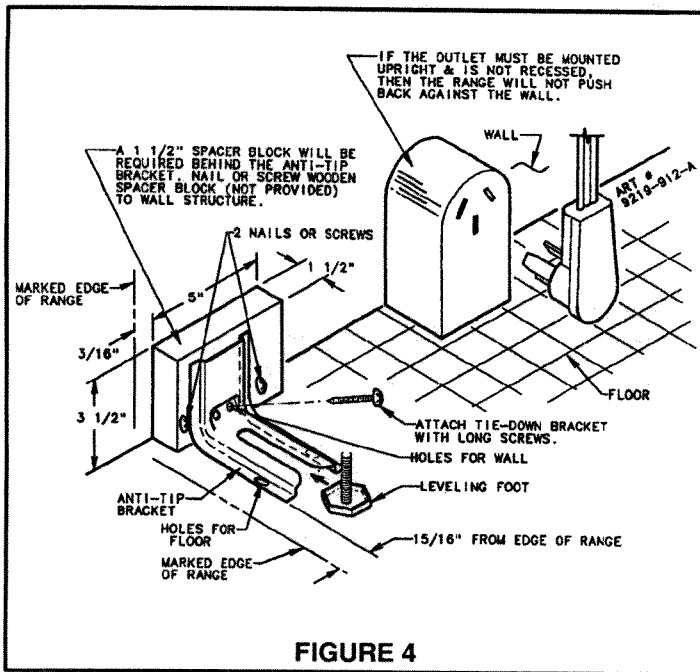


FIGURE 4

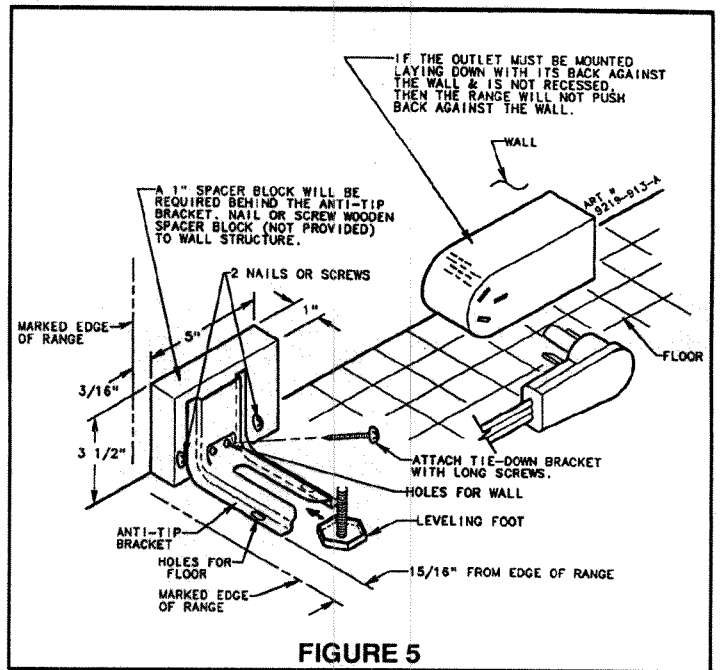


FIGURE 5

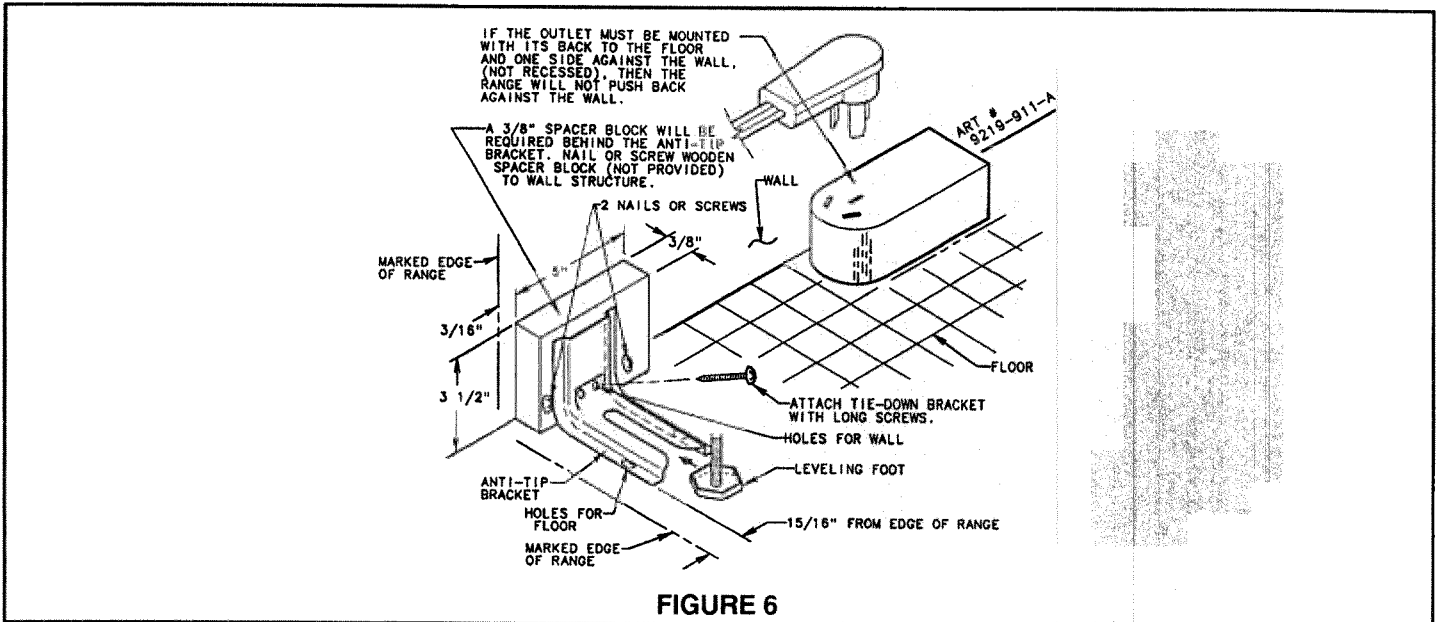


FIGURE 6

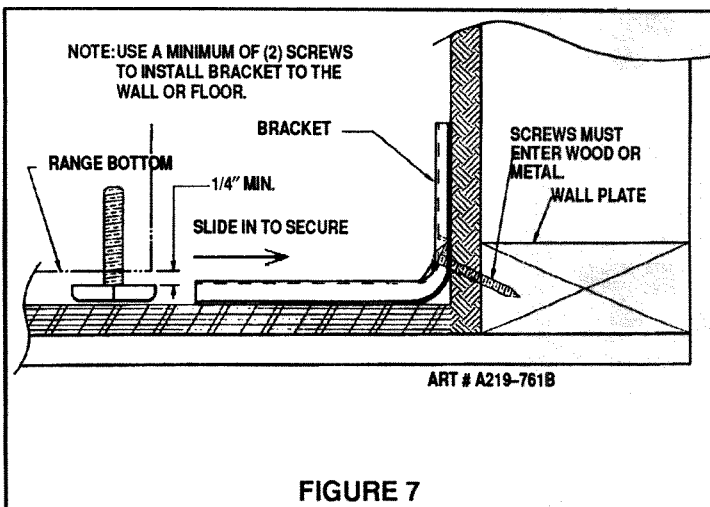


FIGURE 7

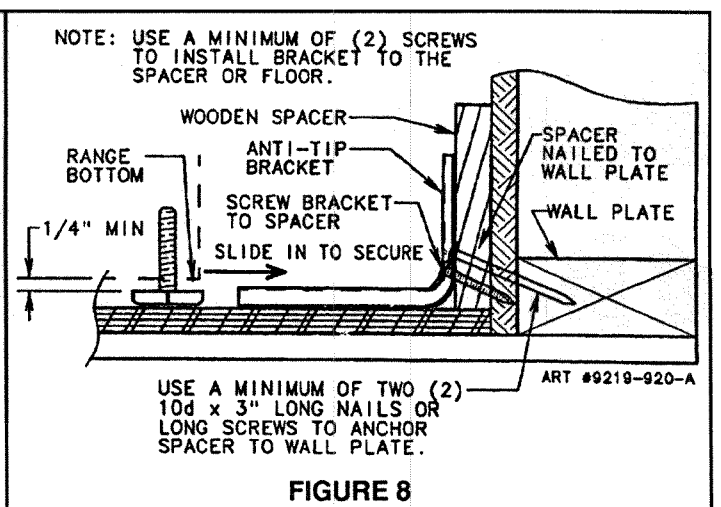


FIGURE 8

# Connecting The Range

## ELECTRIC SUPPLY

The range must be installed in accordance with Local and National Electric Code (NEC) ANSI/NFPA No. 70-1993. See rating plate on front of range for total connected kw rating.

## OUTSIDE WIRING

Your local utility company will tell you whether the present electric service to your home is adequate. It may be necessary to increase the size of the wiring to the house and service switch to take care of the electrical load demanded by the range. The kilowatt rating for the range is specified on the name plate on the range.

## HOUSE WIRING

Most local Building Regulations and Codes require that all electrical wiring be done by licensed electricians. All wiring should conform to Local and National Electrical Codes. This range requires a single phase three wire 120/240 volt, 60 Hz, AC circuit. Wiring codes require a separate circuit be run from the main entrance panel to the range and that it be equipped with separate disconnect switch and fuses, either in the main entrance panel or in a separate switch and fuse box. In some communities, a solid or flexible continuous armored conduit must be used from main entrance panel to the terminal box on the rear of the range. Others will permit the termination of the range circuit at a polarized three or four

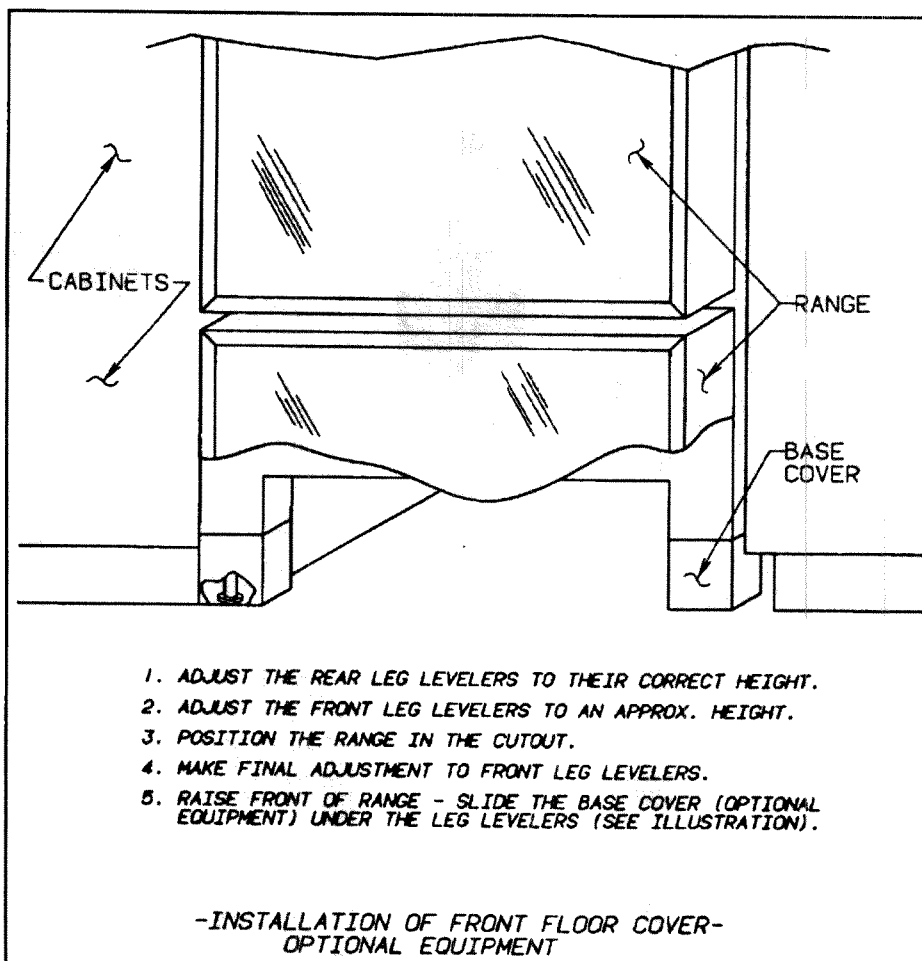
wire plug-in outlet placed at a convenient point near the back of the range. The range is then connected to this outlet through an approved service cord (pigtail) fastened securely to the terminal block with proper strain relief at the range and a three or four pronged plug at the opposite end.

## RANGE CONNECTIONS

On models using service cords (Pigtail) the front surface of the range outlet must be mounted flush to wall. See figures 10A and 10C.

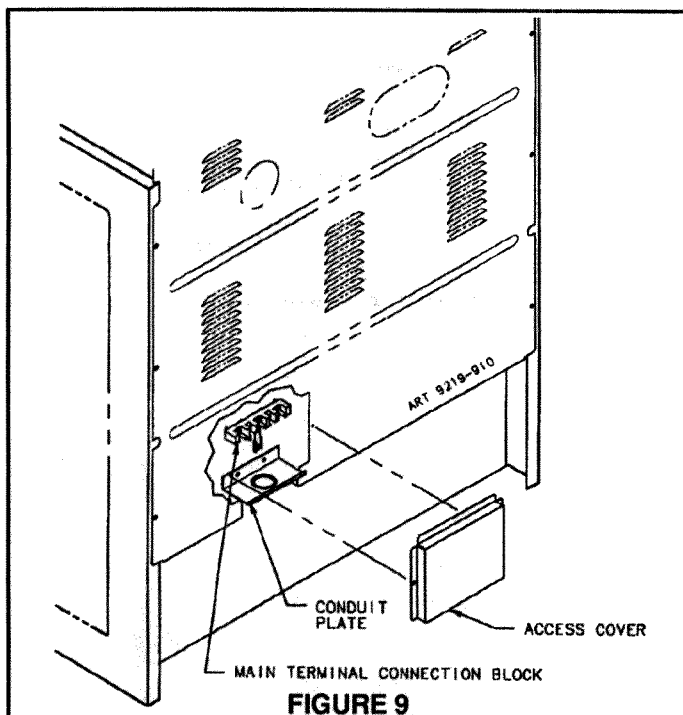
On models not provided with a service cord and models having a conduit, connection to the power supply is necessary. REMEMBER – mobile homes and some LOCAL CODES DO NOT PERMIT GROUNDING THROUGH NEUTRAL. Hence, 4-wire service MUST be provided for such installations. All others permit 3-wire service, use COPPER WIRE ONLY. Make connections as explained below and with reference to the appropriate illustration. (See figures 10A thru 10D). After installation, insure tightness of all electrical connections and replace all covers.

**NOTE:** For cord replacement – **ONLY** a power supply cord rated at 240 volts minimum, 40 amperes or 50 amperes power supply cord that is marked for use with nominal 1 3/8" (34.93 mm) diameter connection opening, with closed loop terminals and marked for use with ranges shall be used.



Remove terminal block access cover from range back. (See figure 9).

For service cord (pigtail) use, remove knockout ring from conduit plate. (See figures 10A and 10C).



### 3-WIRE SERVICE CORD INSTALLATION FIGURE 10A

1. Insure that the copper ground strap **IS CONNECTED** between the middle post of the main terminal connection block and the range chassis.
2. The middle wire of the service cord **MUST** connect to the neutral (middle) post of the main terminal connection block. The other two wires of the service cord connect to the outside posts of the main terminal connection block. Polarity is unimportant.
3. Position strain relief with flanges on top of conduit plate as shown and secure to service cord.

### 3-WIRE CONDUIT INSTALLATION FIGURE 10B

1. The range conduit must be routed and properly connected to an approved electrical junction box behind the range.
2. The red and black wires from the range conduit must respectively connect to the red and black service wires. An approved wire connector must be used.

3. Both the white wire and the uninsulated (bare) wire from the conduit should connect to the white service wire as shown. The bare wire is the range chassis ground.

### 4-WIRE SERVICE CORD INSTALLATION (MOBILE HOMES) FIGURE 10C

1. The copper ground strap connected between the neutral (middle) post of the main terminal block and the chassis **MUST** be removed and discarded. Keep the green ground screw. Only a 4 conductor cord should be used.
2. The green wire from the service cord must connect to the range chassis using the green ground screw.
3. The white wire of the service cord must connect to the neutral (middle) post of the main terminal block. The other two wires of the service cord connect to the red and black posts of the main terminal block, respectively.
4. Position the strain relief with flanges on top of conduit plate as shown and secure to service cord.

### 4-WIRE CONDUIT INSTALLATION (MOBILE HOMES) FIGURE 10D

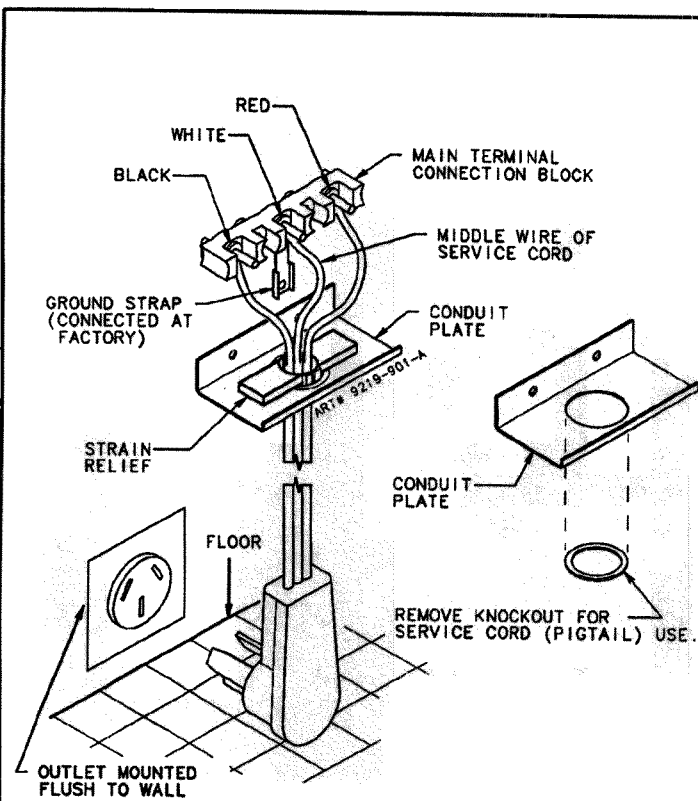
1. The range conduit must be routed and properly connected to an approved electrical junction box behind the range.
2. The red and black wires from the range conduit must respectively connect to the red and black service wires. An approved wire connector must be used.
3. The white wire from the conduit must be connected to the white service wire.
4. The uninsulated (bare) wire from the conduit must be connected either to a green or bare service wire.

### CONVERSION FROM 3-WIRE TO 4-WIRE SERVICE

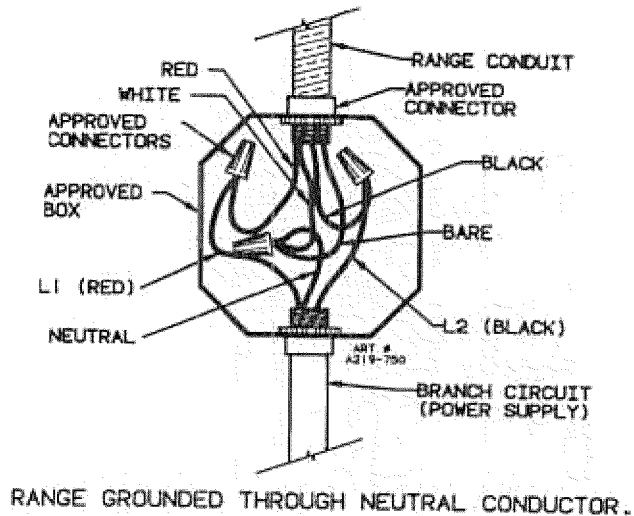
(Free-Standing Models Only With 3-Wire Service Cord Attached).

Disconnect range from power. Remove the access cover on back of range and remove the 3-wire service cord from the main terminal block. Follow instructions as outlined in figure 10C to connect the 4-wire service cord.

**NOTE:** Cord replacement – **ONLY** a power supply cord rated at 240 volts minimum, 40 amperes or 50 amperes power supply cord that is marked for use with nominal 1 3/8" (34.93 mm) diameter connection opening, with closed loop terminals and marked for use with ranges shall be used.

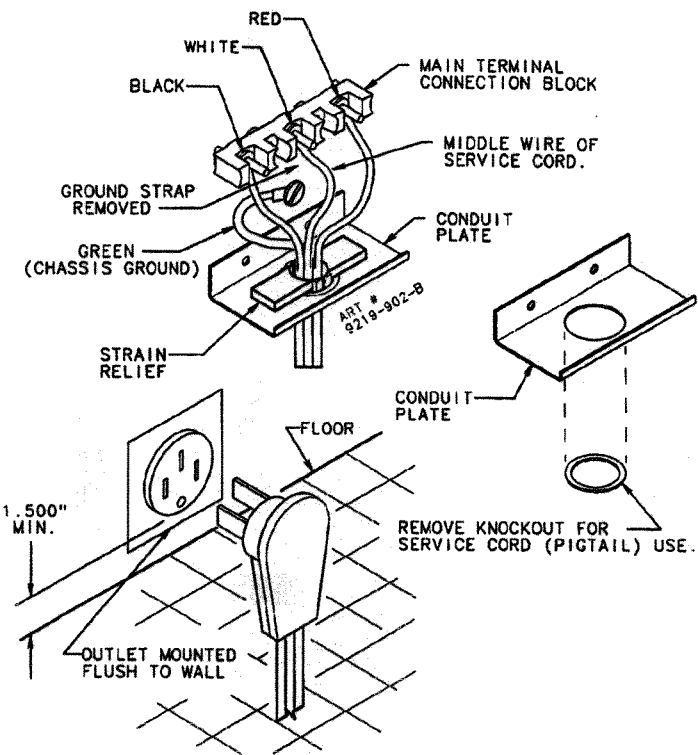


**FIGURE 10A**  
**NORMAL - 3 WIRE PLUG**

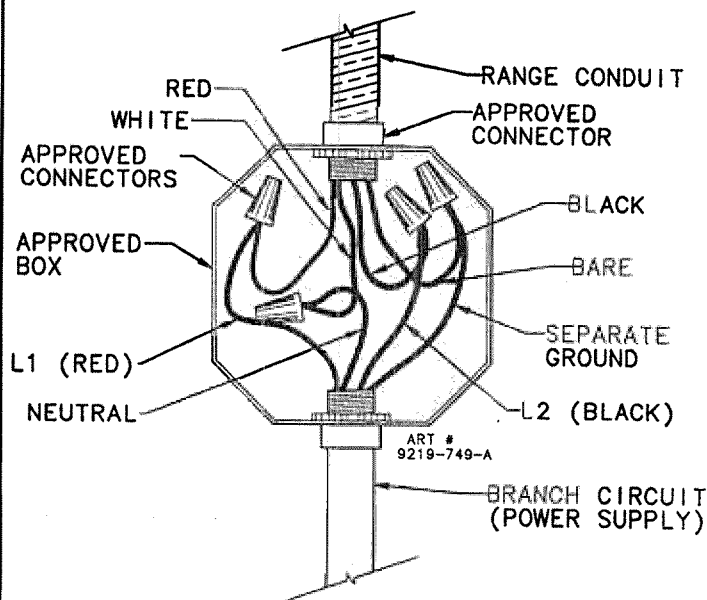


**RANGE GROUNDED THROUGH NEUTRAL CONDUCTOR.**

**FIGURE 10B**  
**NORMAL - 3 WIRE CONDUIT**



**FIGURE 10C**  
**MOBILE HOME - 4 WIRE PLUG**



**WIRING METHOD IF CODE DOES NOT PERMIT GROUNDING THROUGH NEUTRAL CONDUCTOR & ALSO REQUIRED IN MOBILE HOMES.**

**FIGURE 10D**  
**MOBILE HOME - 4 WIRE CONDUIT**