

MK-100 TILE SAW OWNER'S MANUAL PARTS LIST & OPERATING INSTRUCTIONS

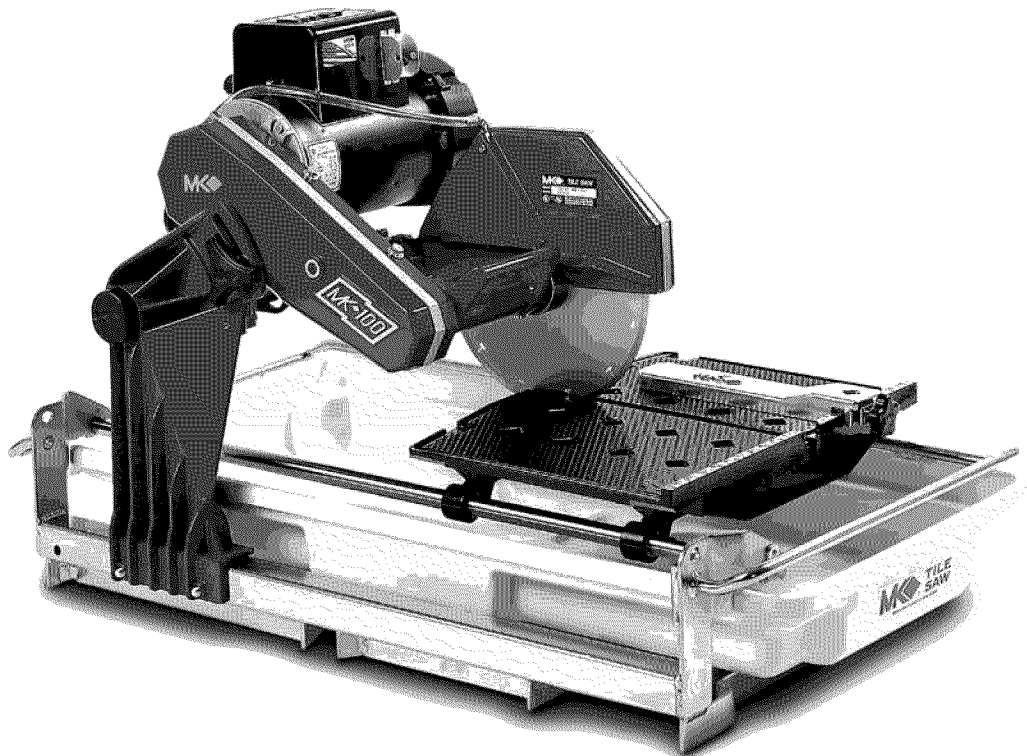

Revision 100	08.2011
Manual Part# 158192	

Caution: Read all safety and operating instructions before using this equipment. This parts list **MUST** accompany the equipment at all times.

INTRODUCTION

Congratulations on your purchase of a MK-100 Tile Saw. We are certain that you will be pleased with your purchase. MK Diamond takes pride in producing the finest construction power tools and diamond blades in the industry.

Operated correctly, your MK-100 Tile Saw should provide you with years of service. In order to help you, we have included this manual. This owners manual contains information necessary to operate and maintain your MK-100 Tile Saw safely and correctly. Please take the time to familiarize yourself with the MK-100 Tile Saw by reading and reviewing this manual.

Read and follow all safety, operating and maintenance instructions.

If you should have questions concerning your MK-100 Tile Saw, please feel free to call our friendly customer service department at: 800 421-5830

Regards,

MK Diamond

NOTE THIS INFORMATION FOR FUTURE USE:

MODEL NUMBER:	
SERIAL NUMBER:	
PURCHASE PLACE:	
PURCHASE DATE:	

NOTE: For your (1) one year warranty to be effective, complete the warranty card (including the Serial Number) and mail it in as soon as possible.

TABLE OF CONTENTS

SAFETY

Safety Messages	4
General Safety Precautions	4-6
California Proposition 65 Message	6
Hazard Symbols	7
Electrical Requirements	8-10
Safety Label Locations	11
Product Specifications	12

UNPACKING, TRANSPORT and ASSEMBLY

Unpacking	13
Contents	13
Transport	14
Stand	15
Assembly	16-17

SETUP, STARTUP, ADJUSTMENT, OPERATION and SHUTDOWN

Setup	18-20
Operation	20-23
Cutting Head Adjustment	24-26
Cleanup	27

MAINTENANCE AND TROUBLESHOOTING

Maintenance	28-33
Troubleshooting	34

EXPLODED VIEW AND PARTS LIST

Exploded View & Parts List	36-39
----------------------------	-------

ACCESSORIES ORDERING and RETURN INSTRUCTIONS

Theory of Diamond Blades	40
Accessories	41
Ordering Information	42
Return Material Policy	42
Packaging Instructions	42
Authorized Service Centers	42

Read and follow all safety, operating and maintenance instructions. Failure to read and follow these instructions could result in injury or death to you or others. Failure to read and follow these instructions could also result in damage and/or reduced equipment life.

SAFETY MESSAGES

A safety message alerts you to potential hazards that could hurt you or others. Each safety message is preceded by a safety alert symbol () and one of three words: **DANGER**, **WARNING**, or **CAUTION**.



DANGER You **WILL** be **KILLED** or **SERIOUSLY INJURED** if you do not follow directions.



WARNING You **CAN** be **KILLED** or **SERIOUSLY INJURED** if you do not follow directions.



CAUTION You **CAN** be **INJURED** if you do not follow directions. It may also be used to alert against unsafe practices.

DAMAGE PREVENTION AND INFORMATION MESSAGES

A Damage Prevention Message is to inform the user of important information and/or instructions that could lead to equipment or other property damage if not followed. Information Messages convey information that pertains to the equipment being used. Each message will be preceded by the word **NOTE**, as in the example below.

NOTE: Equipment and/or property damage may result if these instructions are not followed.

GENERAL SAFETY PRECAUTIONS AND HAZARD SYMBOLS

In order to prevent injury, the following safety precautions and symbols should be followed at all times!

SAFETY PRECAUTIONS



ALWAYS read this Owner's Manual before operating the machine.



ALWAYS keep the Blade Guards in place.



REMOVE ADJUSTING KEYS AND WRENCHES

Form a habit of checking to see that keys and adjusting wrenches are removed from the power tool before it is turned on.



KEEP WORK AREA CLEAN

Cluttered work areas and benches invite accidents.



DO NOT USE IN DANGEROUS PLACES

DO NOT use power tools in damp or wet locations nor expose them to rain. Always keep the work area well lighted.



KEEP CHILDREN AWAY

All visitors and children should be kept a safe distance from work area.

**MAKE THE WORKSHOP KID PROOF**

Make the workshop kid proof by using padlocks, master switches or by removing starter keys.

**DO NOT FORCE THE TOOL**

A power tool will do a job better and safer operating at the rate for which it was designed.

**USE THE RIGHT TOOL**

DO NOT force a tool or an attachment to do a job that it was not designed to do.

**USE THE PROPER EXTENSION CORD**

If using an extension cord make sure it is in good condition first. When using an extension cord, be sure to use one heavy enough to carry the current your product will draw. An undersized cord will cause a drop in line voltage that will result in a loss of power and overheating. Table on Page 10 shows the correct AWG size to use depending on cord length and nameplate ampere rating. If in doubt, use the next heavier gage. The smaller the gage number, the heavier the cord.

USE PROPER APPAREL

DO NOT wear loose clothing, gloves, neckties, rings, bracelets, or other jewelry that may be caught in moving parts. Non-slip footwear is recommended. Wear protective hair covering to contain long hair.



ALWAYS wear approved eye protection.



ALWAYS wear approved respiratory protection.

**SECURE WORK**

Clamps or a vise should be used to hold work whenever practical. Keeping your hands free to operate a power tool is safer.

**DO NOT OVERREACH**

Keep proper footing and balance at all times by not overreaching.

**MAINTAIN TOOLS WITH CARE**

Keep tools clean for the best and safest performance. Always follow maintenance instructions for lubricating, and when changing accessories.

**DISCONNECT TOOLS**

Power tools should always be disconnected before servicing or when changing accessories, such as blades, bits, cutters, and the like.



ALWAYS place the power **ON/OFF** switch in the **OFF** position when the saw is not in use.

**USE RECOMMENDED ACCESSORIES**

Consult the owner's manual for recommended accessories. Using improper accessories may increase the risk of personal or by-stander injury.

**NEVER STAND ON THE TOOL**

Serious injury could occur if a power tool is tipped, or if a cutting tool is unintentionally contacted.

**CHECK FOR DAMAGED PARTS**

Before using a power tool, check for damaged parts. A guard or any other part that is damaged should be carefully checked to determine if it would operate properly and perform its intended function. Always check moving parts for proper alignment or binding. Check for broken parts and mountings and all other conditions that may affect the operation of the power tool. A guard, or any damaged part, should be properly repaired or replaced.

**DIRECTION OF FEED**

ALWAYS feed work into a blade or cutter against the direction of rotation. A blade or cutter should always be installed such that rotation is in the direction of the arrow imprinted on the side of the blade or cutter.

**NEVER LEAVE A TOOL UNATTENDED**

TURN POWER OFF - Do not leave a tool until it comes to a complete stop. Always turn a power tool OFF when leaving the work area, or when a cut is finished.

CALIFORNIA PROPOSITION 65 MESSAGE**WARNING**

Some dust created by power sanding, sawing, grinding, drilling, and other construction activities contain chemicals known (to the State of California) to cause cancer, birth defects or other reproductive harm. Some examples of these chemicals are:

- Lead, from lead-based paints
- Crystalline silica, from bricks and cement and other masonry products
- Arsenic and chromium, from chemically treated lumber

For further information, consult the following sources:

<http://www.osha.gov/SLTC/silicacrystalline/index.html>

<http://www.cdc.gov/niosh/consilic.html>

<http://oehha.ca.gov/prop65/law/P65law72003.html>

<http://www.dir.ca.gov/Title8/sub4.html>

Your risk from these exposures varies depending on how often you do this type of work. To reduce your exposure to these chemicals, work in a well-ventilated area, and work with approved safety equipment, such as those dust masks that are specially designed to filter out microscopic particles.

HAZARD SYMBOLS

**ELECTRICAL SHOCK**

NEVER touch electrical wires or components while the motor is running. They can be sources of electrical shock which could cause severe injury or burns.

**ROTATING PARTS**

Keep hands, feet, hair, and clothing away from all moving parts to prevent injury. Never operate the motor with covers, shrouds, or guards removed.

**OVER SPEED**

NEVER tamper with the governor components or settings to increase the maximum speed. Severe personal injury and damage to the motor or equipment can result if operated at speeds above maximum.

**DO NOT EXPOSE TO RAIN**

DO NOT expose to rain or use in damp locations.

**WARNING**

Sawing and drilling generates dust. Excessive airborne particles may cause irritation to eyes, skin and respiratory tract. To avoid breathing impairment, always employ dust controls and protection suitable to the material being sawed or drilled; See OSHA (29 CFR Part 1910.1200). Diamond Blades improperly used are dangerous. Comply with American National Standards Institute Safety Code, B7.1 and, Occupational Safety and Health Act covering Speed, Safety Guards, Flanges, Mounting Procedures, General Operating Rules, Handling, Storage and General Machine Conditions

ELECTRICAL REQUIREMENTS AND GROUNDING INSTRUCTIONS

In order to prevent potential electrical shock and injury, the following electrical safety precautions and symbols should be followed at all times!



WARNING

In case of a malfunction or breakdown, grounding provides a path of least resistance for electric current to reduce the risk of electric shock. This tool is equipped with an electric cord having an equipment-grounding conductor and a grounding plug. The plug must be plugged into a matching outlet that is properly installed and grounded in accordance with all local codes and ordinances.

- Do not modify the plug provided – if it will not fit the outlet; have the proper outlet installed by a qualified electrician.
- Improper connections of the equipment-grounding conductor can result in a risk of electric shock. The equipment-grounding conductor is the insulated conductor that has an outer surface that is green, with or without yellow stripes. If repair or replacement of the electric cord or plug is necessary, do not connect the equipment-grounding conductor to a live terminal.
- Check with a qualified electrician or service personnel if the grounding instructions are not completely understood, or if in doubt as to whether the tool is properly grounded.
- Use only 3-wire extension cords that have 3-prong grounding plugs and 3-pole receptacles that accept the tool's plug.
- Repair or replace a damaged or worn cord immediately.



WARNING

This tool is intended for use on a circuit that has an outlet that looks like the one shown in Sketch A. The tool has a grounding plug that looks like the plug illustrated in Sketch A. A temporary adapter, which looks like the adapter illustrated in Sketches B and C, may be used to connect this plug to a 2-pole receptacle as shown in Sketch B, if a properly grounded outlet is not available. The temporary adapter should be used only until a properly grounded outlet can be installed by a qualified electrician. The green-colored rigid ear, lug, and the like, extending from the adapter must be connected to a permanent ground such as a properly grounded outlet box.

NOTE: Use of a temporary adapter is not permitted in Canada.

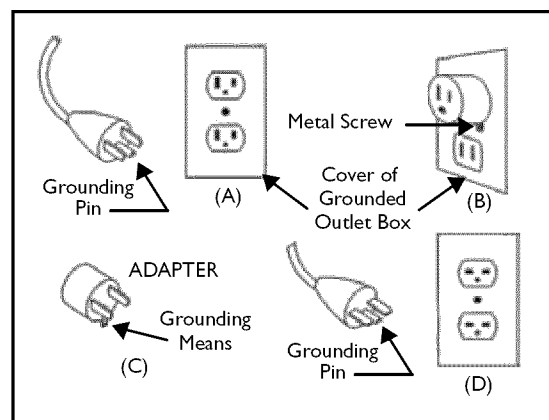

Circuit and Adapter Information

**WARNING**

To avoid the possibility of the appliance plug or receptacle getting wet, position the machine to one side of a wall mounted receptacle. This will prevent water from dripping onto the receptacle or plug. A “drip loop,” shown in the picture below, should be arranged by the user to properly position the power cord relative to the power source.

The “drip loop” is that part of the cord below the level of the receptacle, or the connector, if an extension cord is used. This method of positioning the cord prevents the travel of water along the power cord and coming in contact with the receptacle.

If the plug or receptacle gets wet, **DO NOT** unplug the cord. Disconnect the fuse or circuit breaker that supplies power to the tool. Then unplug and examine for presence of water in the receptacle.

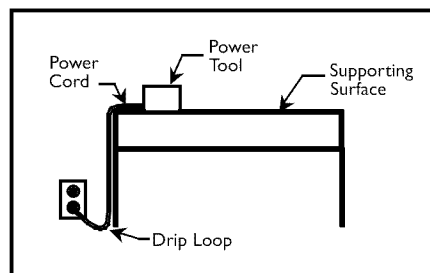

Drip Loop Information

**WARNING**

Use only extension cords that are intended for outdoor use. These extension cords are identified by a marking “Acceptable for use with outdoor appliances; store indoors while not in use.” Use only extension cords having an electrical rating not less than the rating of the product. Do not use damaged extension cords. Examine extension cords before using and replace if damaged. Do not abuse extension cords and do not yank on any cord to disconnect. Keep cords away from heat and sharp edges. Always disconnect the extension cord from the receptacle before disconnecting the product from the extension cord.

**WARNING**

To reduce the risk of electrocution, keep all connections dry and off the ground. Do not touch the plug with wet hands.

**WARNING**

Use of under sized extension cords result in low voltage to the motor that can result in motor burnout and premature failure. MK Diamond warns that equipment returned to us showing signs of being run in a low voltage condition, through the use of undersized extension cords will be repaired or replaced totally at the customer's expense. There will be no warranty claim.

To choose the proper extension cord,

- Locate the length of extension cord needed in the table below.
- Once the proper length is found, move down the column to obtain the correct AWG size required for that length of extension cord.

EXTENSION CORD MINIMUM GAGE FOR LENGTH				
VOLTS	TOTAL LENGTH OF CORD IN FEET			
	25 ft. AWG	50 ft. AWG	100 ft. AWG	150 ft. AWG
115v	14	12	Not Recommended	Not Recommended
230v	N/A	14	12	N/A

SAFETY LABEL LOCATIONS

Safety labels contain important safety information. Please read the information contained on each safety label. These labels are considered a permanent part of your saw. If a label comes off or becomes hard to read, contact MK Diamond or your dealer for a replacement.

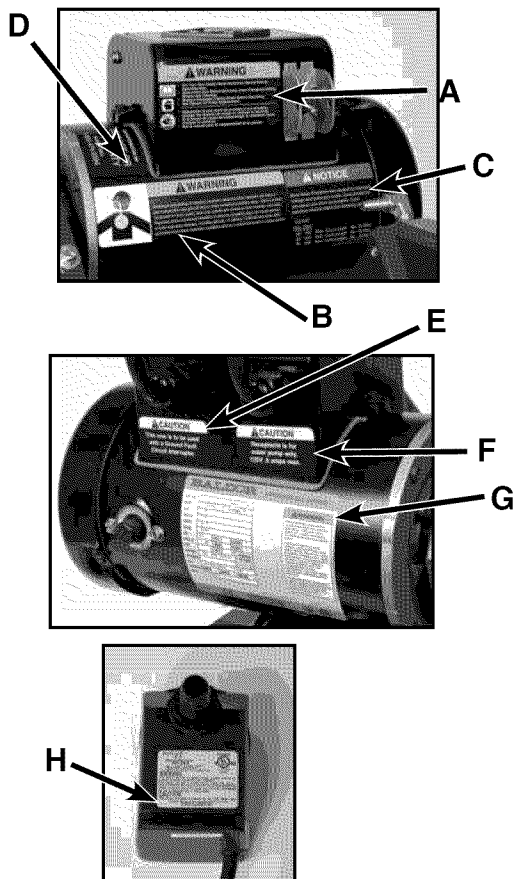

Label A



Label D

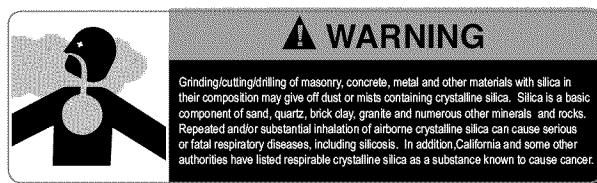

Label B

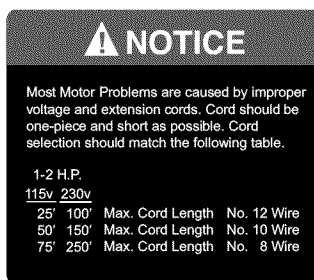

Label C

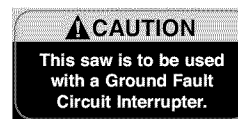

Label E

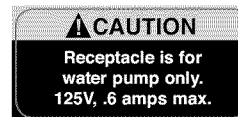

Label F

Tile Master Label Sheet Part#166012

Decal/Label	Location	Description
A	Motor-Side	Warning - Read and Follow Operating Instructions
B	Motor - Front	Warning - Silica Warning
C	Motor - Side	Notice - Receptacle is for Water Pump Only
D	Motor - Back	Service/ Warranty
E	Motor - Side	Caution - Use with GFCI only
F	Motor - Side	Caution - Receptacle for water pump
G	Motor - Side	Motor Specifications
H	Water Pump	Pump Specifications

TILE SAW SPECIFIC WARNINGS

! WARNING

- Wear eye protection.
- Use splash guard for every operation for which it can be used.
- Disconnect saw before servicing, when changing cutting blades, and cleaning.
- Replace damaged cutting blade before operating.

PRODUCT SPECIFICATIONS

The MK-100 is a versatile Tile Saw. Operated and used according to this manual, the MK-100 will provide years of dependable service.

GENERAL DESCRIPTION

The MK-100 Tile Saw is engineered as a tabletop or stand mounted wet tile saw. The saw includes a powerful 120V electric motor. The saw is capable of cutting tile up to twenty (20) inches in length, depth of cut 3".

MOTOR SPECIFICATIONS

Motor specifications for the MK-100 are listed in below.

Voltage	120V
Motor Only Amperage	14.5
Frequency	60Hz
RPM	3400 rpm
Horse Power	1.5 hp
Weight	96 lbs.

BLADE CAPACITY

The MK-100 uses a ten (10) inch (254 mm) diameter, wet cutting continuous rim, MK Diamond blade with a five-eighths (5/8) inch (15.875 mm) arbor.

TILE TYPES

The MK-100 can cut a variety of tile types including stone, masonry, and lapidary products.

NOTE: The MK-100 is not designed to cut plastic or metals.

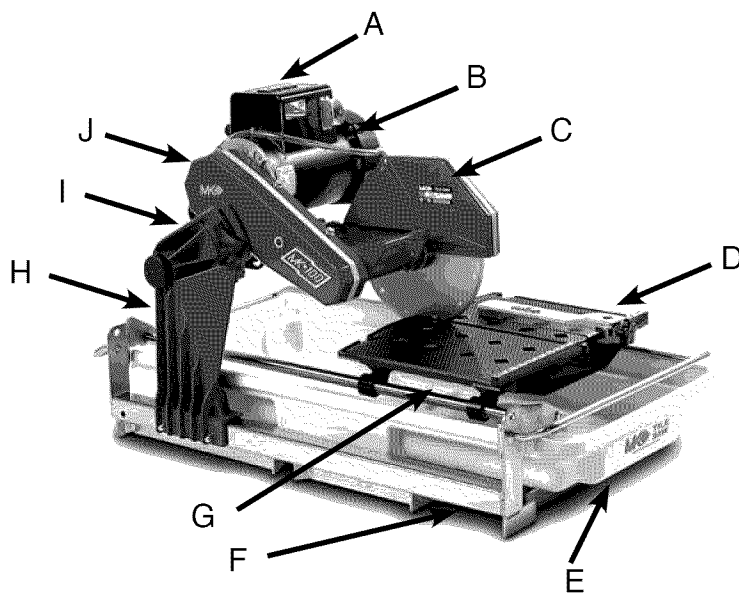

A	Motor
B	Water Pump Tube
C	Blade Guard
D	Cutting Table
E	Water Basin
F	Frame
G	Guide Bar
H	Post
I	Depth of Cut Adjustment Knob
J	Belt Guard

UNPACKING

Your MK-100 has been shipped from the factory thoroughly inspected. Only minimal assembly is required.

! CAUTION Use proper lifting techniques when lifting the MK-100.

If not done, remove the MK-100, Cutting Head and accessory box from the carton.

CONTENTS

In your container, you will find one (1) MK-100 frame and water basin, one (1) MK-100 cutting head, one (1) 10-inch wet cutting continuous rim diamond blade, one (1) adjustable cutting guide, one (1) electric water pump, one (1) 45° miter, one (1) splash guard, one (1) cooling transfer tube, one (1) flow adjusting clamp, one (1) blade wrench, one (1) drain plug, one (1) owner's manual, one (1) pump manual and one (1) warranty card.

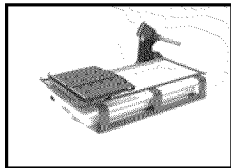

MK-100 Frame and Water Basin

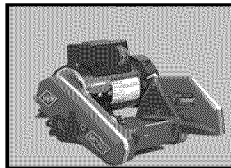

MK-100 Cutting Head

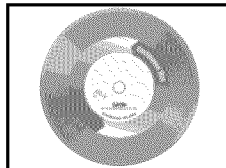

Diamond Blade

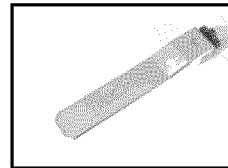

Adjustable Cutting Guide

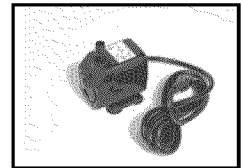

Electric Water Pump

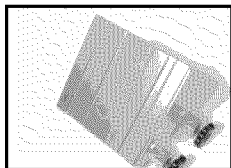

45° Miter

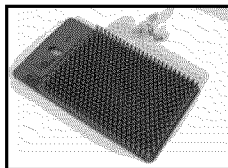

Splash Guard

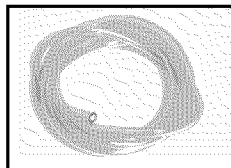

Cooling Transfer Tube



Flow Adjusting Clamp

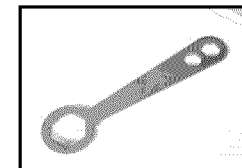

Blade Nut Wrench

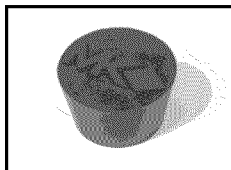

Drain Plug



Owner's Manual

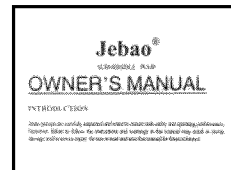

Pump Manual



Warranty Card

TRANSPORT

⚠ CAUTION

1. The MK-100 weighs approximately ninety-six (96) pounds; use care when transporting.
2. Never transport the MK-100 with water in the Water Pan.

The MK-100 is designed with a rigid frame and removable Cutting Head. Two people are required to transport the MK-100 with the Cutting Head installed. The Cutting Head must be removed first, if one person is transporting the saw (see Cutting Head Installation and Removal in the following section).

To lift the saw using two people, each person will grasp the front and back of the frame. To lift the saw using one person, remove the Cutting Head first, and then grasp the front and back of the frame. Transport the Cutting Head and the Frame separately.

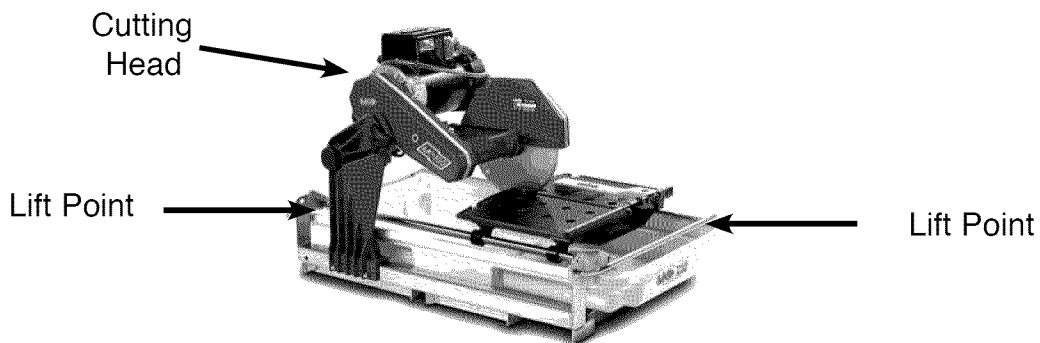

UNIVERSAL STAND

⚠ CAUTION

The MK-100 weighs ninety-six (96) pounds; follow the guidelines in the **TRANSPORT** section when placing it on the stand (MK Diamond Part# 151889).

NOTE: If using the Optional MK Diamond Stand, follow these steps

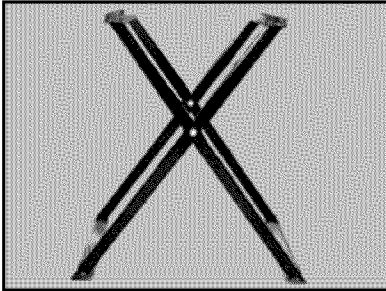

(A)
Open the Universal Stand
and place on flat surface.

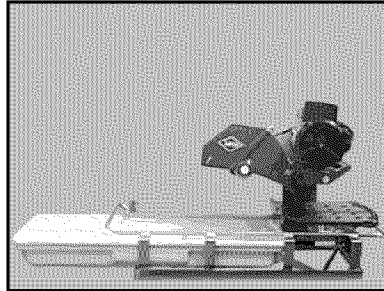

(B)
Remove Water Basin.

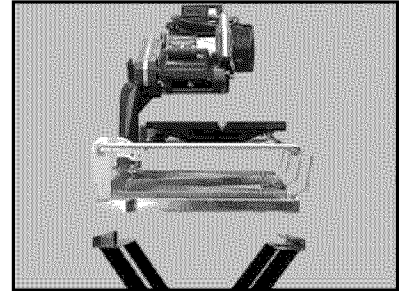

(C)
Orient the Saw to the Stand.

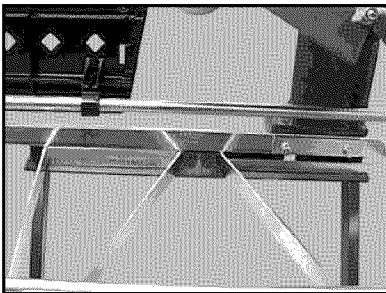

(D)
Seat Left (Post) Side of saw
onto stand between stand
Orientation Pin.

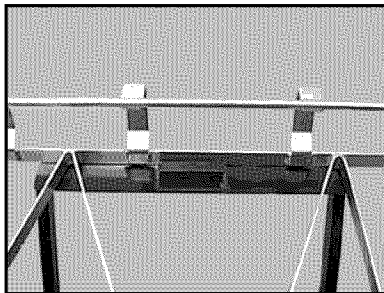

(E)
Seat Right Side of saw onto
stand between stand and
Register Angle.

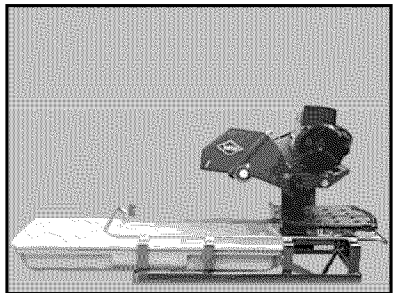

(F)
Reinstall the Water Basin.

ASSEMBLY

Follow the assembly instructions to prepare your MK-100 for operation.

CUTTING HEAD INSTALLATION

NOTE: If the Cutting Head is installed, go to the next step.

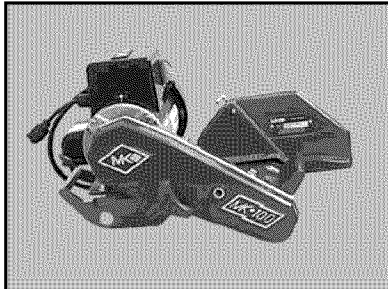

(A)
Remove Adjusting Knob.

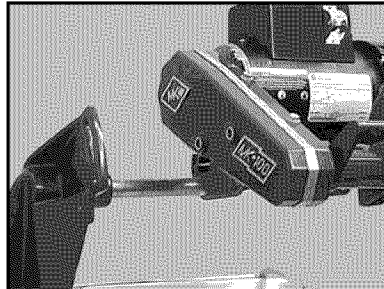

(B)
Align Cutting Head Rear Pivot Hole to the Post Pivot Shaft and slide onto shaft.

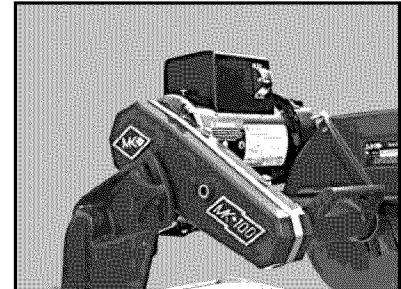

(C)
Install the Cutting Head onto the Post Pivot Shaft and install the Adjusting Knob.

DIAMOND BLADE INSTALLATION

NOTE: When installing the Retaining Nut, do not "cross-thread" and **DO NOT** over tighten the nut.

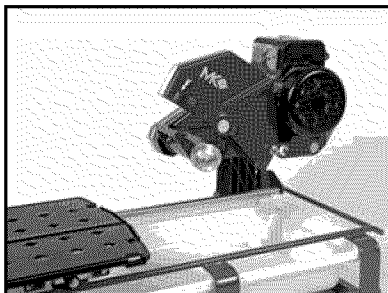

(A)
Position Movable Cutting Table to the front of the saw and raise the Blade Guard.

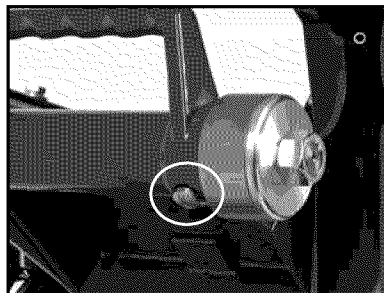

(B)
Locate the Shaft Lock button on the underside of the Cutting Head.

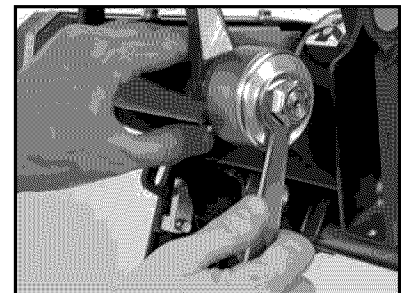

(C)
Depress and hold the Shaft Lock button and remove Retaining Nut and Outer Flange using the Blade Wrench.

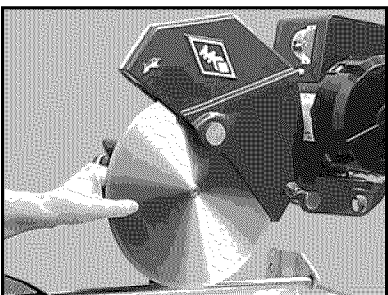

(D)
Install Diamond Blade onto Blade Shaft. Verify the Blade is seated on the Blade Shaft.

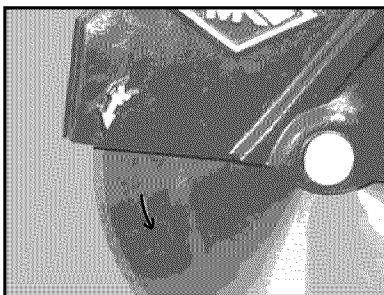

(E)
Check the directional arrow on the blade and direction of rotation is correct.



(F)
Install Outer Flange and Retaining Nut, depress and hold the Shaft Lock button and tighten nut.

ADJUSTABLE CUTTING GUIDE INSTALLATION

NOTE: The Adjustable Cutting Guide can be used on either side of the Diamond Blade.

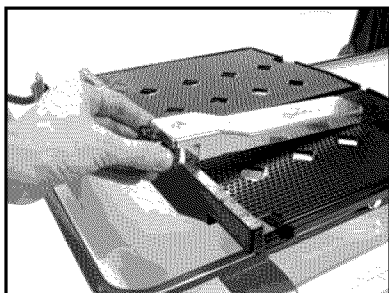

(A)

Loosen Adjustable Cutting Guide retaining thumbscrew and place it over the Movable Cutting Table Ruler/Stop.

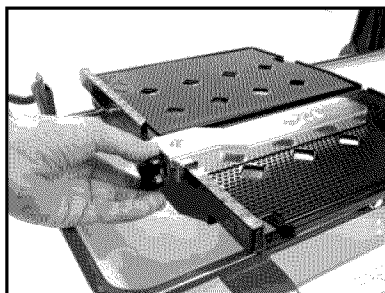

(B)

Place the Adjustable Cutting Guide onto the Movable Cutting Table Ruler/Stop and tighten the retaining thumbscrew.

SPLASH GUARD INSTALLATION

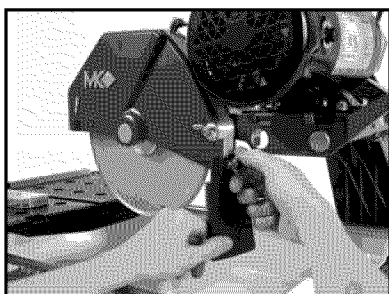

(A)

Install the retaining thumbscrew through the washer and Splash Guard then align to the hole found on back of the Blade Guard and tighten.

WATER PUMP PREPARATION

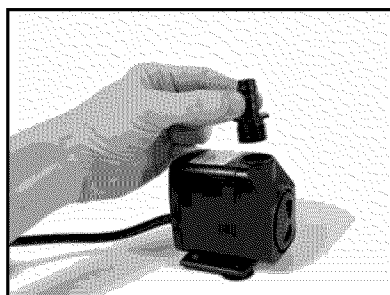

(A)

Install Water Pump Discharge Fitting.

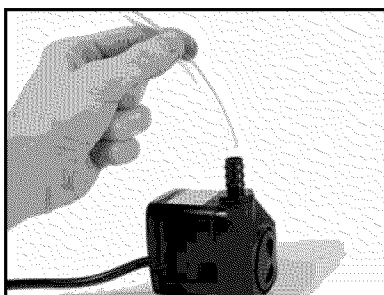

(B)

Press one end of the Cooling Transfer Tube into the Water Pump Discharge Fitting.

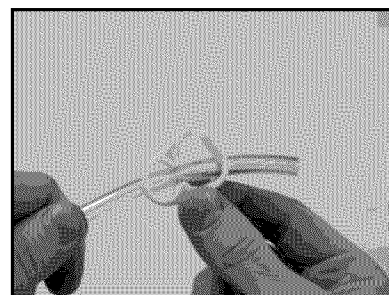

(C)

Slide Cooling Flow Adjusting clamp on to the Cooling Transfer Tube.

PRE-START INSPECTION

Prior to beginning work, a pre-start inspection of the saw should be performed.

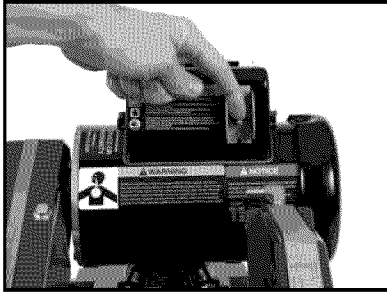

(A)
Ensure the ON/OFF Switch
is in the OFF position.

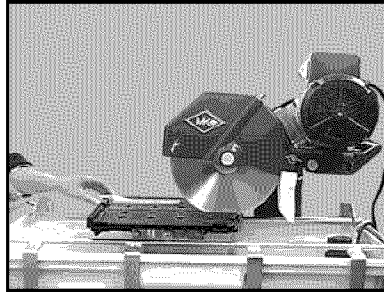

(B)
Verify the Movable Cutting
Table moves freely.

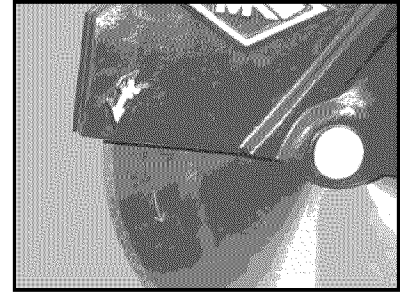

(C)
Inspect the Diamond Blade for
damage. Verify the blade is cor-
rect for the material being cut.

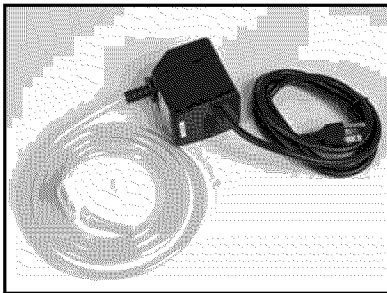

(D)
Inspection the Pump Assem-
bly for damage. Ensure the
cord is free of cracks or cuts.

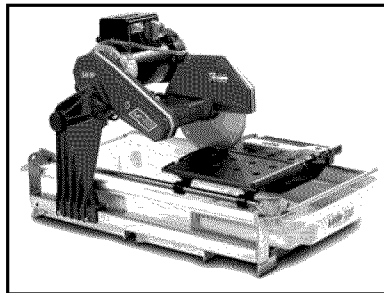

(E)
Inspect the MK-100 for
damage. Ensure the cord is
free of cracks or cuts.

CONNECTING WATER PUMP

⚠ WARNING To prevent the possibility of electrical shock, the MK-100 MUST be de-energized when connecting the Water Pump.
To prevent the possibility of electrical shock, use only MK Diamond qualified replacement parts.

NOTE: To prevent pump damage, the Water Pump must be disconnected from its power supply if cutting with a Dry Blade.

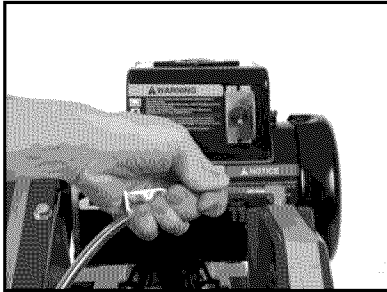

(A)
Connect the Cooling Transfer Tube to the inlet connection of the Blade Guard.

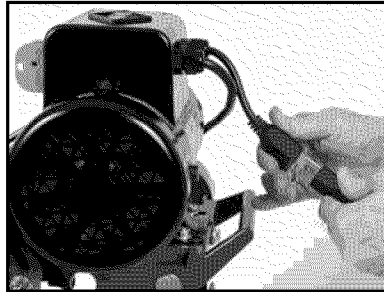

(B)
Connect the Water Pump power cord to the connection found on the back of the motor.

WATER PUMP SETUP FOR OPERATION

The Water Pump can be setup for operation in two ways, external water source or Re-circulation.

EXTERNAL WATER SOURCE

This is the preferred method of cooling.

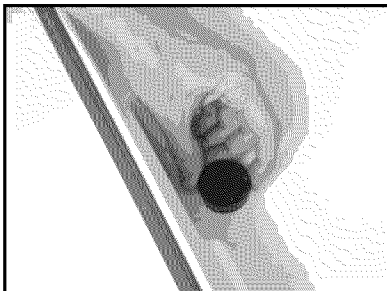

(A)
Remove the Drain Plug.
Place empty container under hole for water drainage.

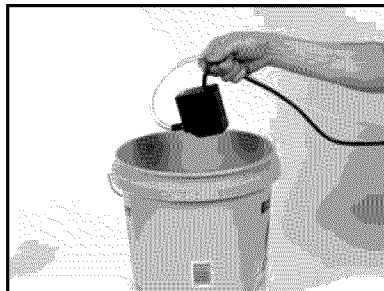

(B)
Place the Water Pump in an external container and fill until water completely covers the Water Pump suction.

RE-CIRCULATION

NOTE: When using the re-circulation method, the water should be changed often for longer pump life.

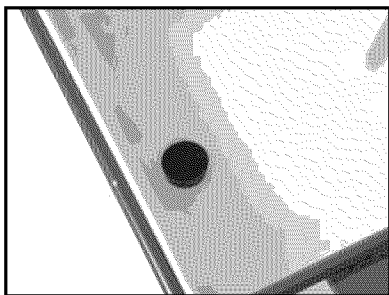

(A)

Ensure the Drain Plug is installed in the Water Basin.

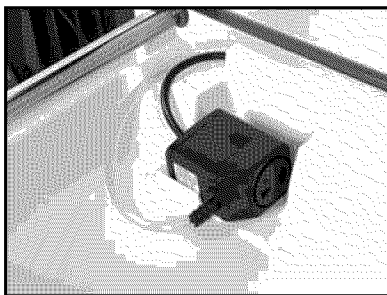

(B)

Place the Water Pump in the back of the Water Basin.

NOTE: Ensure the power cord and cooling tube exit the water basin under the top rail of the frame.

MK-100 SETUP FOR OPERATION



CAUTION

Before powering or starting, check for damage that could prevent this equipment from proper operation or performing its intended function. Check for binding and alignment of moving parts. Check for damaged, broken, or missing parts.

Verify the ON/OFF switch is in the OFF position.

Before connecting the MK-100 to a power supply, be sure the voltage, cycle and phase of the job site power source meet the requirements in the table below.

Voltage	120v
Cycle	60Hz
Phase	1-phase

If using an extension power cord, make sure the length and wire gauge correspond to the requirements listed in the Table on Page 10. An extension power cord that is too small in wire gauge (diameter), or too long in length, will cause the motor to overheat and could cause premature failure.

Use an approved Ground Fault Circuit Interrupter (GFCI).

Do not cover the motor vents as this could lead to motor overheating.

NOTE: In order to avoid breaker tripping, a 20 amp circuit breaker should be used.

PORTABLE GENERATOR

If using a portable generator to provide power, ensure the generator meets the following minimum requirements: 8Kw 120 Volts 20 Amps Single Phase

GROUND FAULT INTERRUPTER

Ground Fault Interrupters (GFCI) provide protection from the dangers of electrical hazards. Receptacles are available having built-in GFCI protection and may be used for this measure of safety. Otherwise a GFCI should be used.

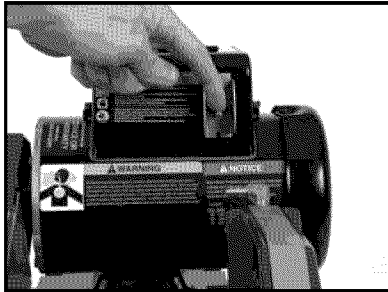

(A)
Ensure the ON/OFF Switch is in the OFF position.

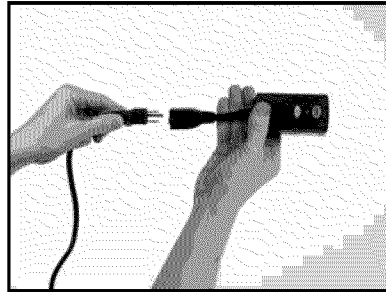

(B)
Plug MK-100 into GFCI.

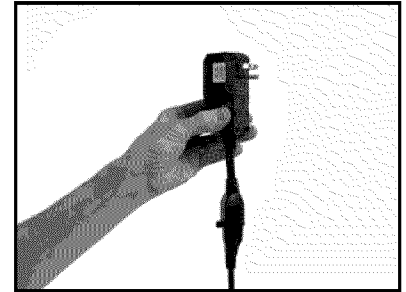

(C)
Plug the GFCI into the power source.



WARNING

If the plug or receptacle does get wet **DO NOT** plug/unplug the cord. Disconnect the fuse or circuit breaker that supplies power to the tool. Then unplug and examine for presence of water in the receptacle.

SET CUTTING DEPTH



CAUTION

When loosening the Cutting Head Adjusting Knob, the Cutting Head will pivot down unless held.

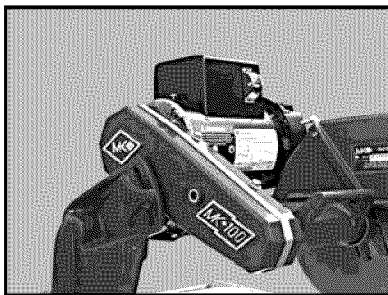

(A)
Loosen Cutting Head Knob and move Cutting Head down.

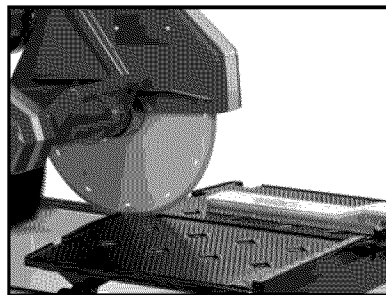

(B)
Set cutting depth approximately 1/4 to 1/2 inch below the surface of the Movable Cutting Table.

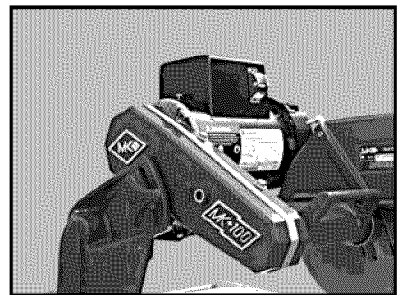

(C)
Ensure the Adjusting Knob is tight.

Cutting Straight Edges

CAUTION **DO NOT FORCE THE TOOL.** It will do the job better and safer at the rate for which it was designed.

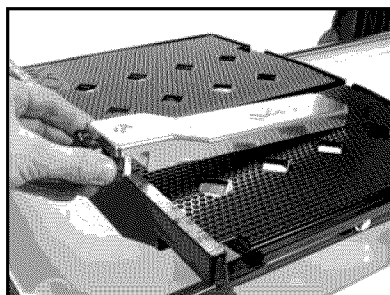

(A)

Loosen the Adjustable Cutting Guide retaining thumbscrew.

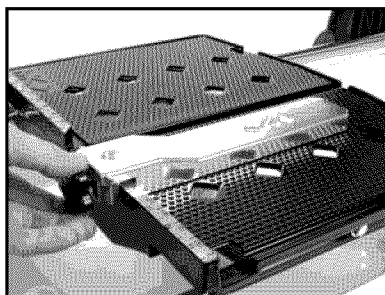

(B)

Position the Adjustable Cutting Guide to desired cut length indicated inside the diamond and tighten.

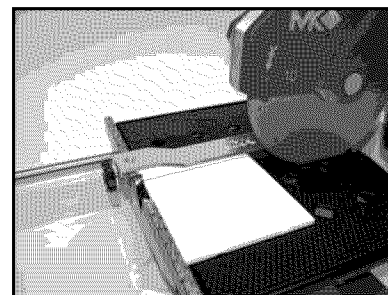

(C)

Place the tile against the Ruler/Stop and Cutting Guide. Turn the motor ON.

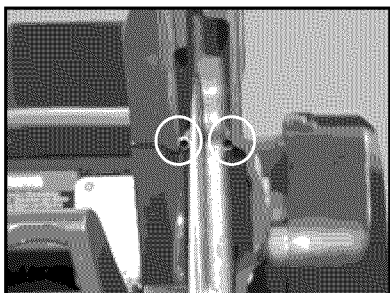

(D)

Verify proper cooling flow on both sides of the blade (See Maintenance Section to increase/decrease flow).

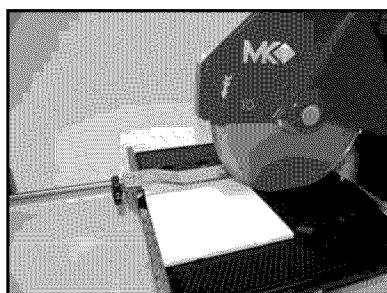

(E)

Perform the cut. Turn the motor OFF when work is complete.

Diagonal Cut

NOTE: To cut diagonals, the Dual 45° Flat Angle Guide (MK Diamond Part No. 134557-MK) should be used.

CAUTION **DO NOT FORCE THE TOOL.** It will do the job better and safer at the rate for which it was designed.

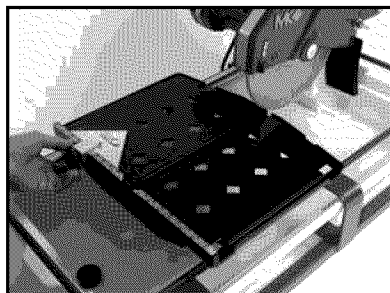

(A)

Position the Dual 45° Flat Angle Guide and tighten the retaining thumbscrew.

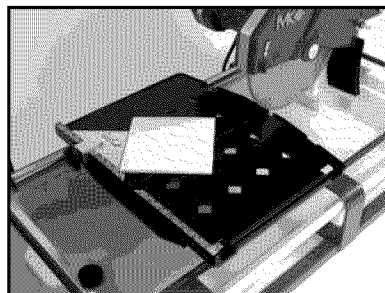

(B)

Position the tile against the Dual 45° Flat Angle Guide and the Ruler/Stop. Turn ON the motor.

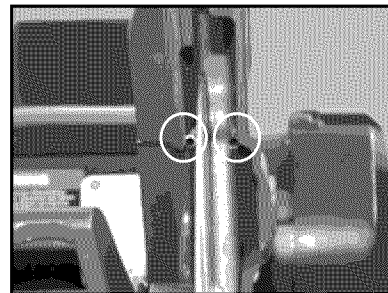

(C)

Verify proper cooling flow on both sides of the blade (See Maintenance Section to increase/decrease flow).

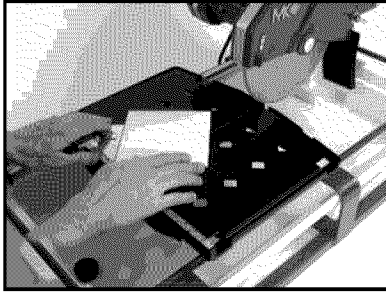

(D)

Perform the cut. Turn the motor OFF when work is complete.

45° Miter Cutting

CAUTION **DO NOT FORCE THE TOOL.** It will do the job better and safer at the rate for which it was designed.

NOTE: To cut 45° Miters, the 45° Bullnose Miter Guide should be used (MK Diamond Part # 134585-MK).

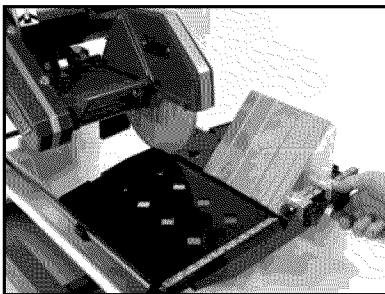

(A)

Position the 45° Bullnose Miter Guide and tighten the retaining thumbscrews.

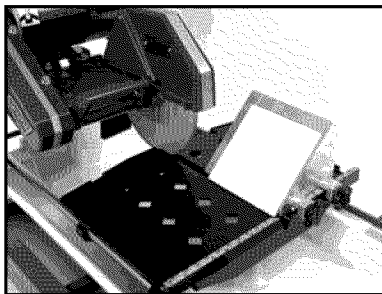

(B)

Position the tile on the 45° Bullnose Miter Guide and the Ruler/Stop. Turn ON the motor.

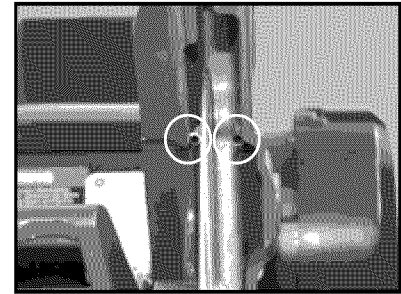

(C)

Verify proper cooling flow on both sides of the blade (See Maintenance Section to increase/decrease flow).

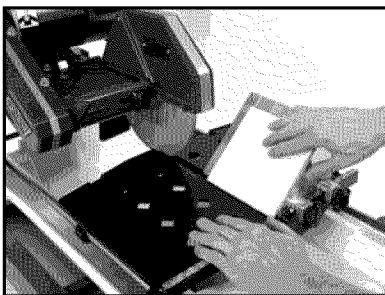

(D)

Perform the cut. Turn the motor OFF when work is complete.

Off-angle Cutting

NOTE: To cut angles other than 45° angles or Miter, a 90° Protractor (MK Diamond Part No. 134569-MK) should be used.

CAUTION **DO NOT FORCE THE TOOL.** It will do the job better and safer at the rate for which it was designed.

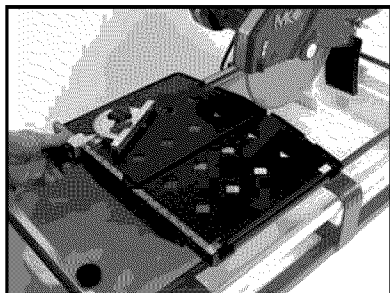

(A)

Place the 90° Protractor on the Ruler/Stop and tighten the retaining thumbscrew.

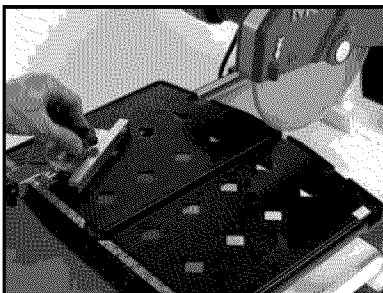

(B)

Set the desired angle and tighten the thumbscrew.



(C)

Position the tile against the 90° Protractor and the Ruler/Stop. Turn the motor ON.

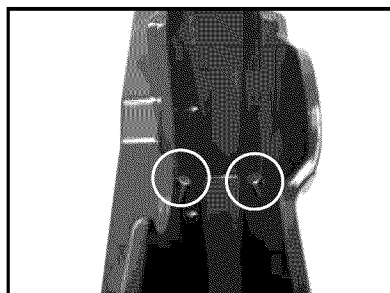

(D)

Verify proper cooling flow on both sides of the blade (See Maintenance Section to increase/decrease flow).



(E)

Perform the cut. Turn the motor OFF when work is complete.

Adjusting the Cutting Head

CAUTION The Cutting Head is heavy. Care must be used when changing the position of the Cutting Head.

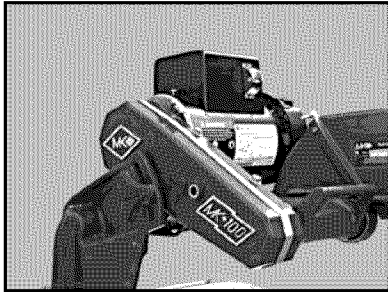

(A)
Remove the blade and then
Adjusting Knob.

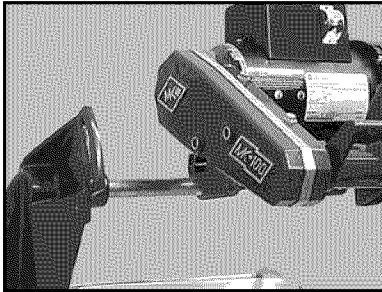

(B)
Remove the Cutting Head from
the rear pivot hole.



(C)
Install the Cutting Head onto
the front pivot hole.

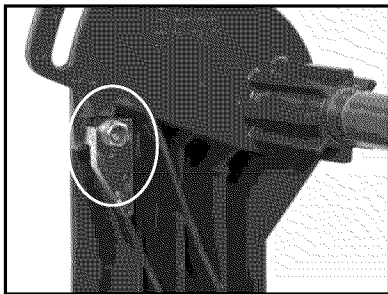

(D)
Move Cutting Head Stop to down
position.

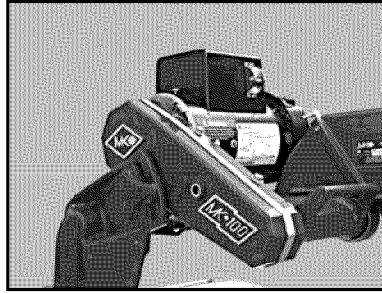

(E)
Install the Adjusting Knob.



(F)
Install Diamond Blade. Set
cutting depth approx. 1/4 to 1/2
inch below the surface of the
Movable Cutting Table.

NOTE: For small tiles (6" tile or smaller) the Cutting Head should be in the rear pivot hole and the Post should be in the forward post retaining hole. For large tiles and maximum cutting length, the Cutting Head should be in the front pivot hole and the Post should be in the rear post retaining hole.

NOTE: Move Cutting Head Stop in upward position when using rear pivot hole and in the down position when using front pivot hole.

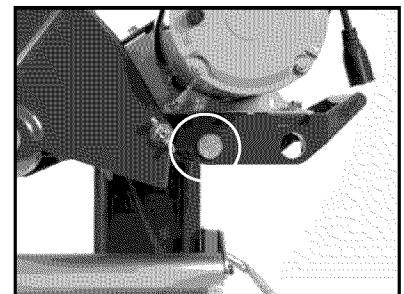

For maximum cutting length,
the Cutting Head should be
in the front pivot hole and the
post should be in the rear post
retaining hole.

Adjusting the Post for Maximum Cutting Length

CAUTION The Cutting Head and Post are heavy. Care must be used when changing the position of the Cutting Head.

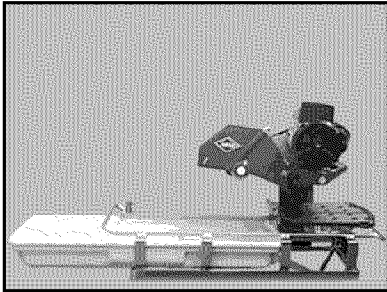

(A)
Remove Water Basin. Blade and Adjusting Knob.

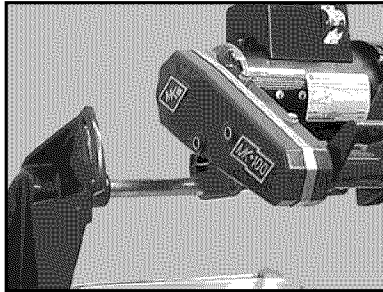

(B)
Remove the Cutting Head (Cutting Head Adjustment pg 25).

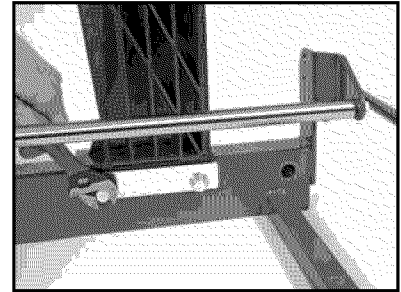

(C)
Loosen the Post Support Plate and Retaining Bolts.

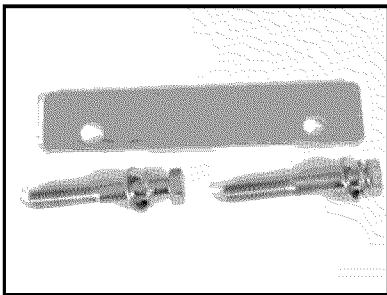

(D)
Remove the Post Support Plate and Retaining Bolts.

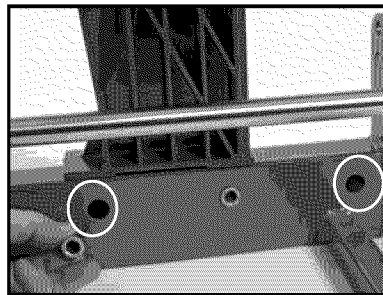

(E)
Remove Standoff, and insert in rear post retaining hole.

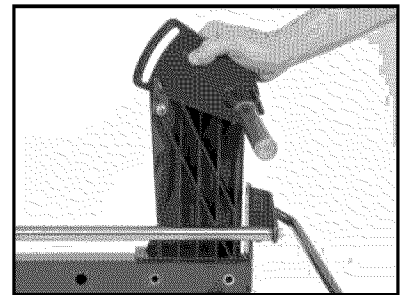

(F)
Relocate the Post to the rear Post retaining holes.

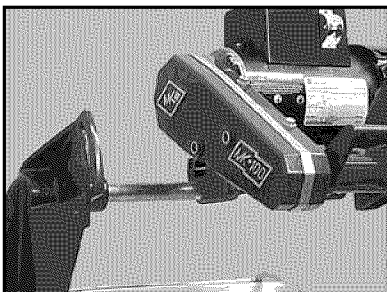

(G)
Install the Cutting Head in rear Pivot Hole (Cutting Head Adjustment pg 25).

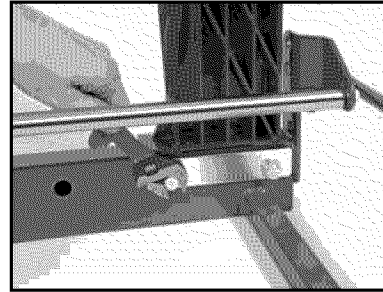

(H)
Install the Post Support and tighten Retaining Bolts.

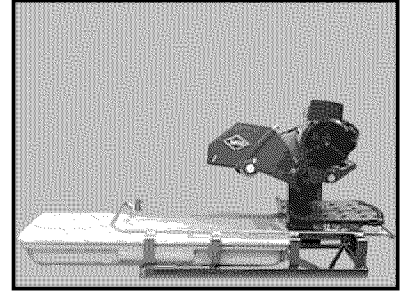

(I)
Install the Water Basin and blade.

CLEANUP

NOTE: If an external water source was used, steps A through C may be skipped.
Dispose of waste water in accordance with applicable Federal, State and Local laws.

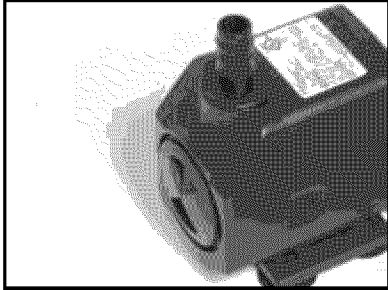

(A)
Clean the Water Pump suction of all debris

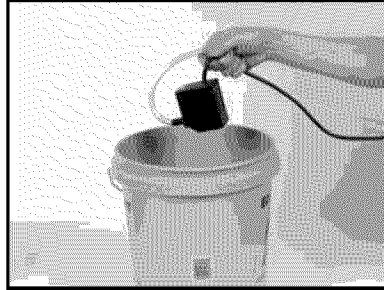

(B)
Place the Water Pump in an external container

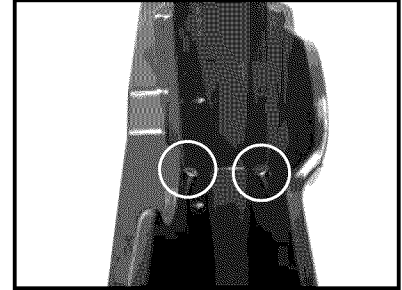

(C)
Run the MK-100 until clear water is seen at the blade cooling ports (Approx. 1 min.)

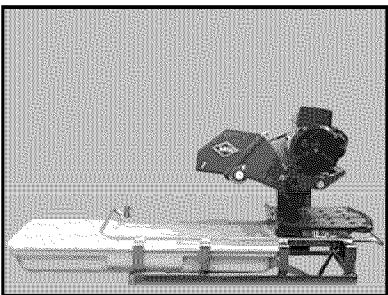

(D)
Remove the Water Basin and clean.

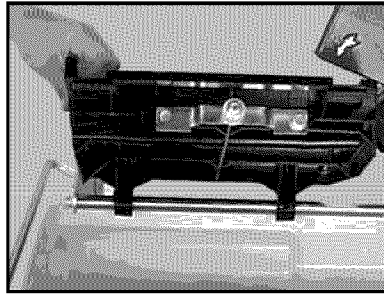

(E)
Clean the Movable Cutting Table Roller Wheel and Frame Support

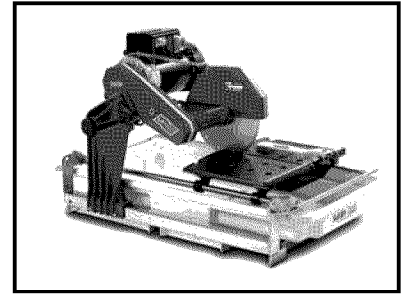

(F)
Clean the remainder of the MK-100

MAINTENANCE

Perform the following after initial purchase and operation of the MK-100.

Maintenance Following Use

To extend the life of the MK-100, the following procedure should be performed after each use. Lubricate all points listed below with light oils such as, 3 in 1, WD-40, etc.

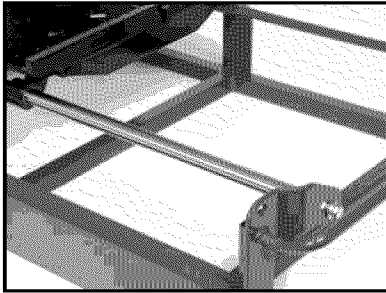

(A)
Lubricate the Guide Bar.

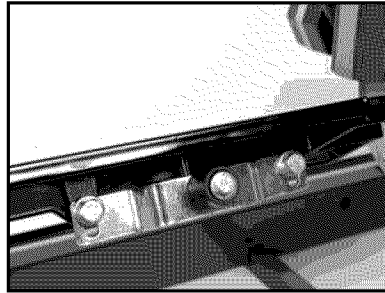

(B)
Lubricate the Roller Wheel
Assembly.

Monthly Maintenance

The following maintenance should be performed monthly.

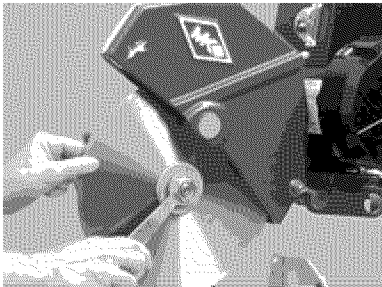

(A)
Remove the Diamond Blade.

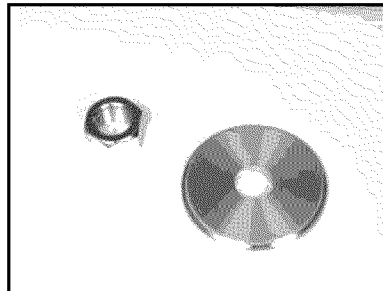

(B)
Clean and lubricate the Outer
Flange and Retaining-nut.

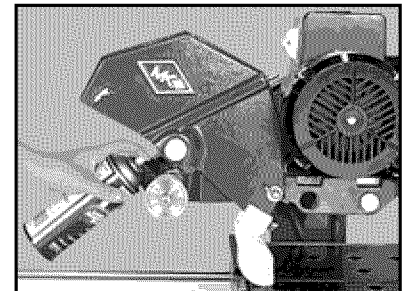

(C)
Lubricate the Arbor Shaft.

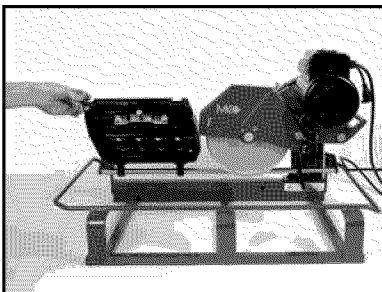

(D)
Verify the Roller Wheel As-
sembly is tight and in good
condition.

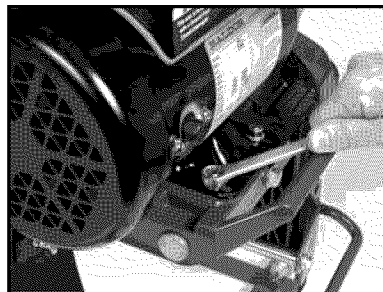

(E)
Verify all motor mounting
Bolts are tight.

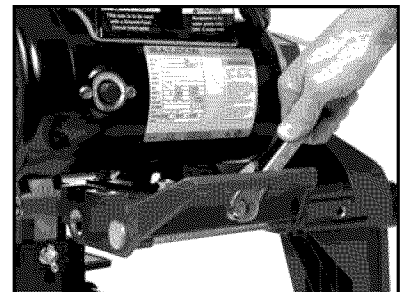

(F)
Verify the Motor Adjustment
Strap is tight.

Monthly Maintenance Cont.

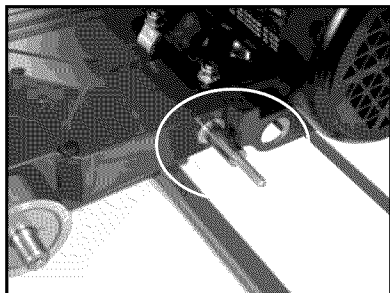

(G)
Remove the Blade Guard.
Lubricate the Blade Guard
Pivot Shaft.

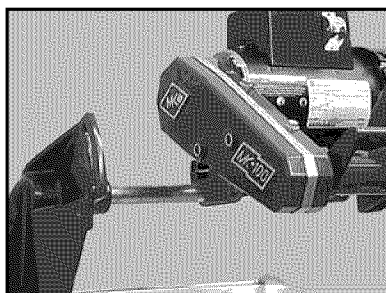

(H)
Remove the Cutting Head (Cut-
ting Head Adjustment pg 25).

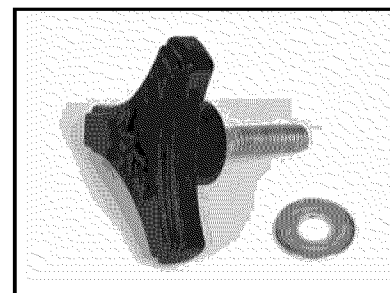

(I)
Lubricate the threads on the
Cutting Head Adjustment
Knob.

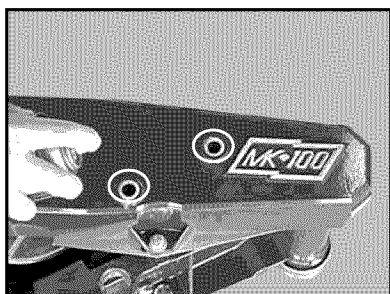

(J)
Lubricate the Cutting Head
Adjustment Knob retaining
holes.

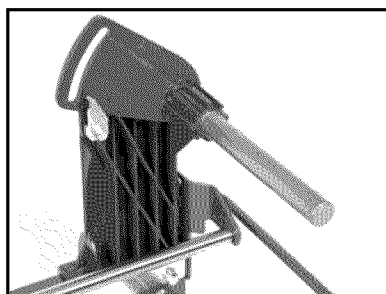

(K)
Lubricate the Cutting Head
Pivot Shaft.

Flow Adjustment

NOTE: If flow to the diamond blade requires adjustment, perform the following actions.

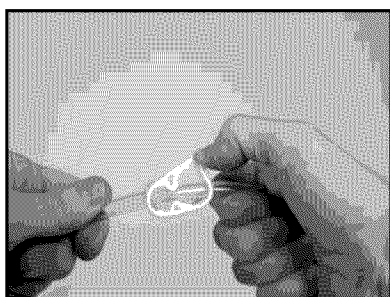

(A)
Increase cooling flow by
releasing the Flow Adjusting
Clamp.

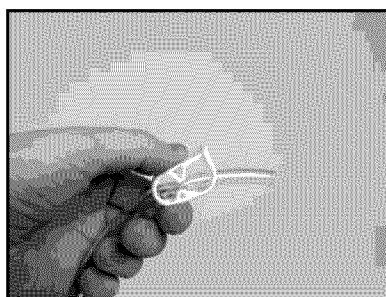

(B)
Reduce cooling flow by
pressing down on the Flow
Adjusting Clamp.

Blade Dressing

Like most cutting instruments, a diamond blade performs best when it is dressed. Over time and use, diamonds on the outer edge of the blade may become smoothed or "glazed" over. This will reduce grinding efficiency and may cause the blade to "wander" or bend giving the illusion of an alignment problem. When this occurs, the blade will need to be dressed. The diamond blade can be dressed using the MK Dressing Stick (MK Diamond part number 152972) and by following the steps below.

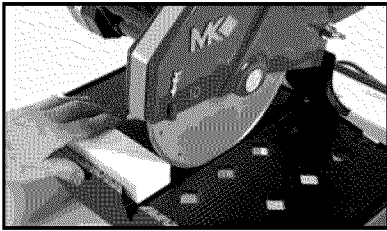

(A)

Cut the Dressing Stick 7 or 8 times to dress the Blade.

Diamond Blade Change-out

NOTE: When installing the Retaining Nut, **DO NOT** "cross-thread" and **DO NOT** over tighten the nut.

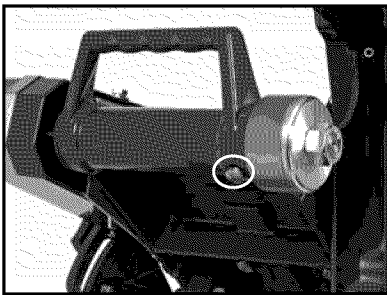

(A)

Locate the Shaft Lock, push button on the underside of the Cutting Head.

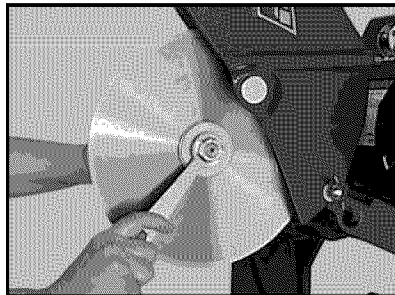

(B)

Remove Retaining Nut and Outer Flange, depress and hold the Shaft Lock hold button and loosen.

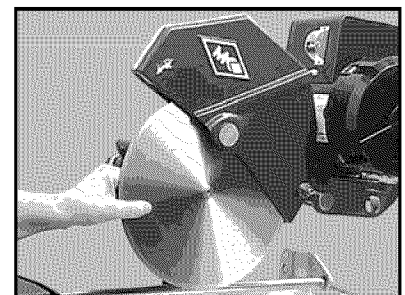

(C)

Remove the Diamond Blade.

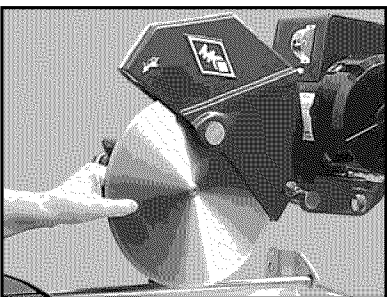

(D)

Install the new Diamond Blade onto Blade Shaft. Install Outer Flange and Retaining Nut.

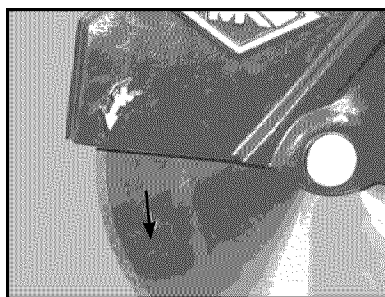

(E)

Verify the Blade is seated on the Blade Shaft and direction of rotation is correct.

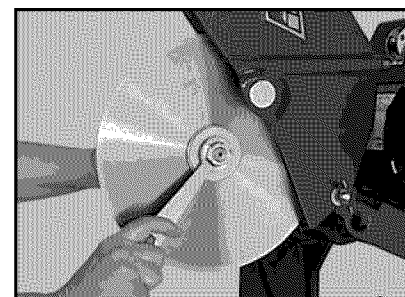

(F)

Depress and hold the Shaft Lock button and tighten Retaining Nut.

V-Belt Inspection, Adjustment and Replacement

The MK-100 is designed with power transmission Micro-V Belt. In order to ensure the MK-100 operates a peak efficiency, the Micro-V Belt should be inspected monthly, and changed if the Micro-V Belt shows damage and/or excessive wear.

NOTE: When a new belt is installed, it should be inspected and re-tensioned after the first forty-eight (48) hours of operation.

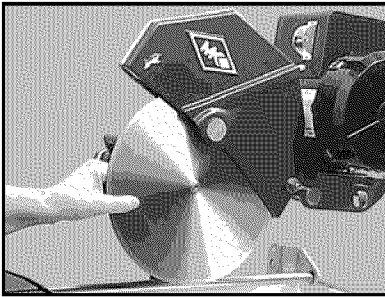

(A)
Remove the Diamond Blade.

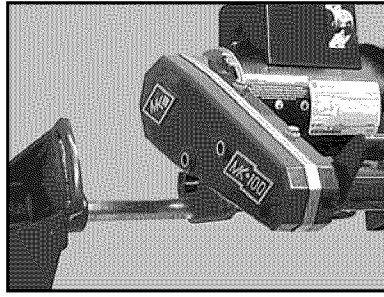

(B)
Remove the Cutting Head
(See Cutting Head Adjust-
ment Pg. 25).

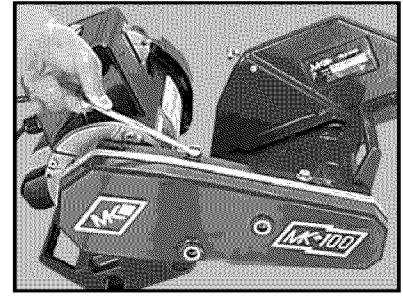

(C)
Remove the two top Belt Guard
Bolts.

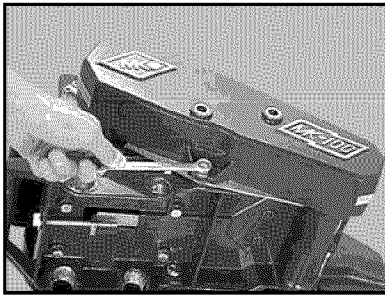

(D)
Remove Belt Guard bottom
bolt.

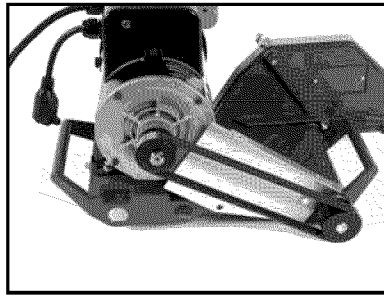

(E)
Inspect the Micro-V Belt for
cracks, fraying, separation and
wear. Go to step H if replace-
ment is required.

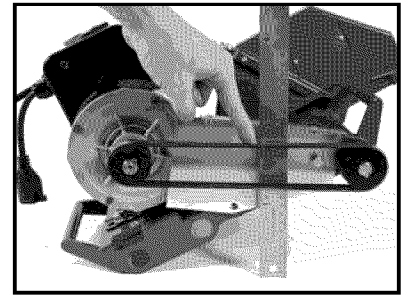

(F)
Check belt for proper tension. If
tension correct, go to step Q (proper
tension should be 1/8-inch
deflection).

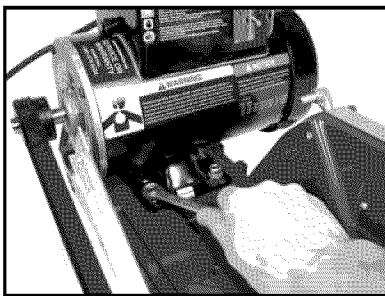

(G)
Loosen the two front motor
mounting bolts. If re-tension-
ing only, go to step N.



(H)
Loosen the two back motor
mounting bolts.

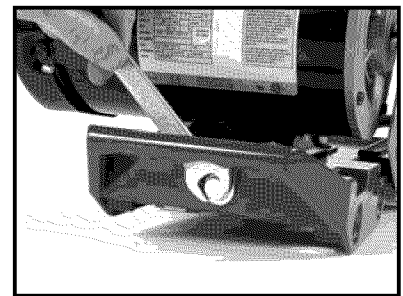

(I)
Loosen the Motor Adjustment Strap.

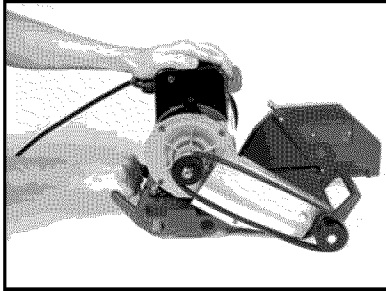

(J)

Push the motor toward the front of the Cutting Head to loosen the V-Belt.

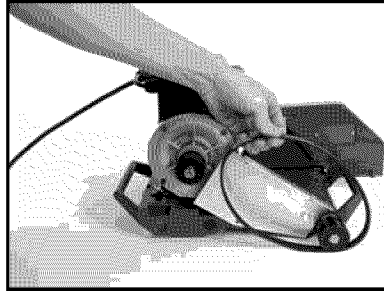

(K)

Remove the V-Belt.

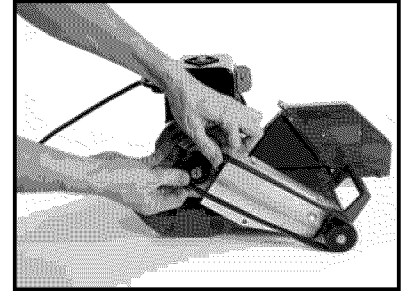

(L)

Install the new V-Belt (MK Diamond Part No. 158194).

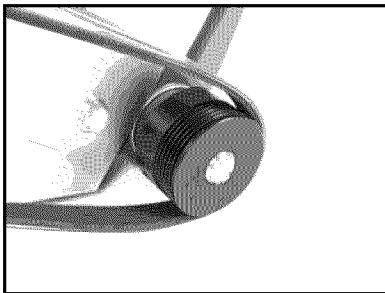

(M)

Verify the V-Belt is seated in the grooves of both pulleys.

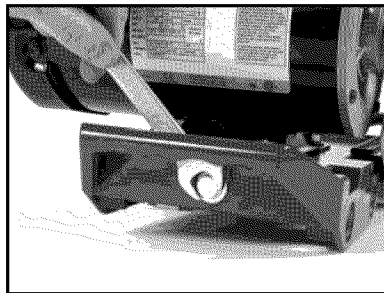

(N)

Tighten the Motor Adjustment Strap to remove slack.

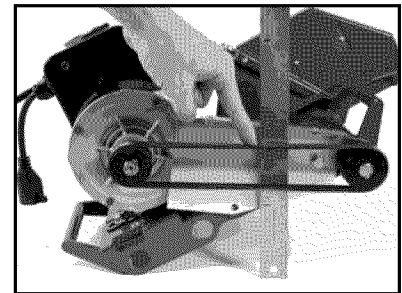

(O)

Check V-Belt tension (proper tension 1/8-inch) Repeat steps N and O until proper Micro-V Belt tension is achieved.

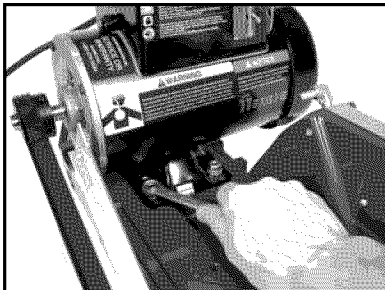

(P)

Tighten the four motor mounting bolts.

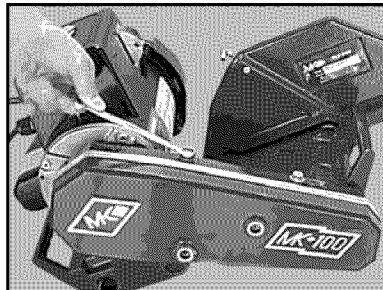

(Q)

Install the Belt Guard.

Cooling Flow

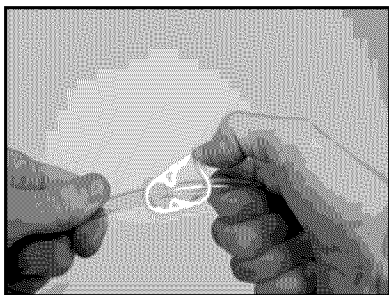

(A)
Check cooling flow Adjusting
Clamp open.

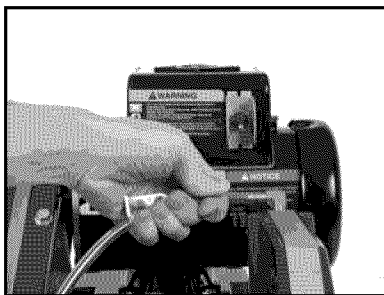

(B)
Remove the Cooling Transfer
Tube from the Blade Guard
inlet.

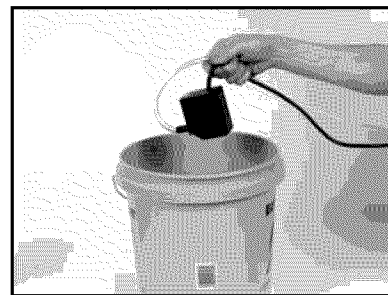

(C)
Place Pump into a bucket of
water and check flow.

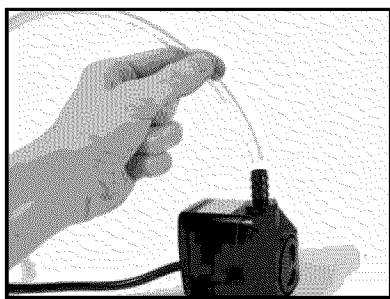

(D)
Remove the Cooling Transfer
Tube and check flow.

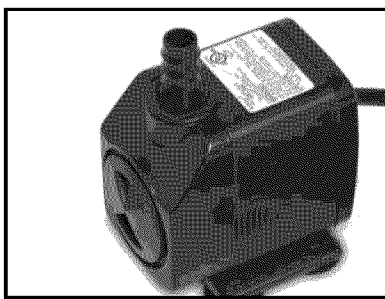

(E)
Inspect and clean pump. See
Pump Manual.

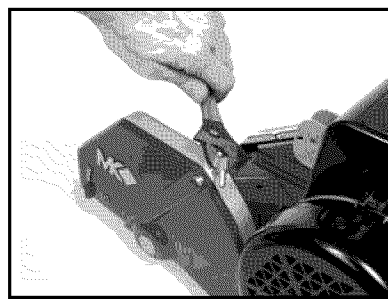

(F)
Remove the Blade Guard
Intake Fitting and check.

NOTE: "Rodding" cooling channels is performed by inserting a small wire rod through the cooling inlet on top of the Blade Guard and directing the rod out through each of the cooling flow tubes located on the underside of the Blade Guard. The cooling channels should be "rodded" until all ports are free of foreign debris.

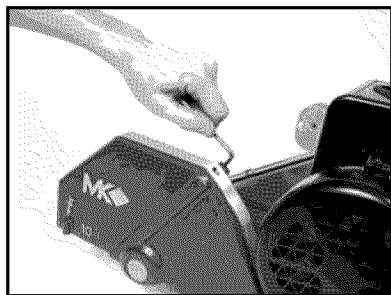

(G)
Remove the Cooling Chan-
nel cover screws.

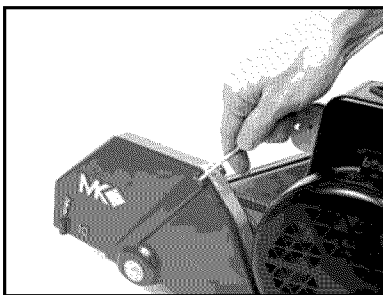

(H)
Rod Cooling Channels and
recheck flow.

Movable Cutting Table Does Not Move Correctly

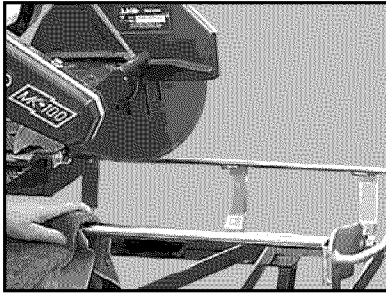

(A)

Check that the Guide Bar is clean - clean if dirty.

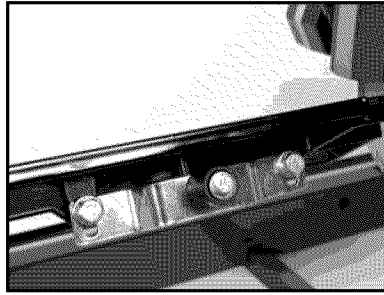

(B)

Check the Movable Cutting table Roller Wheels for wear, replace if necessary.

Blade will not cut properly

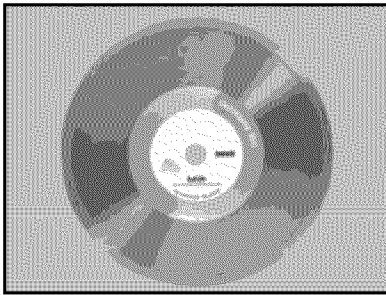

(A)

Check for smoothness or "Glazing" (See Blade Dressing Section)

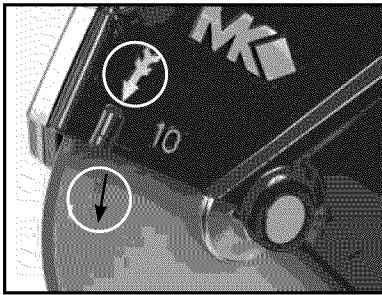

(B)

Check for proper blade rotation. Ensure arrow engraved on blade matches the directional arrow on Blade Guard.

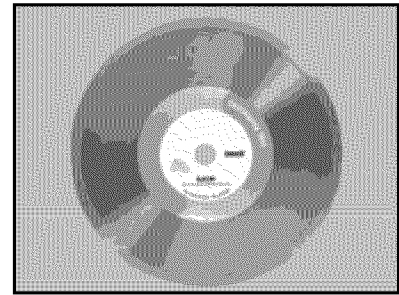

(C)

Ensure the Blade Core is not bent. Verify the blade is correct for the material being used.

Blade Stops Turning

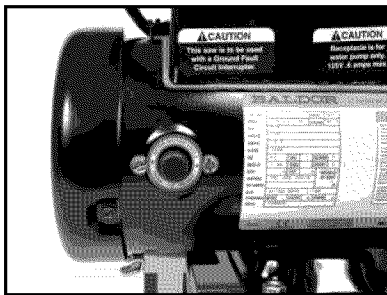

(A)

Allow motor to cool and depress motor Overload Reset Switch.

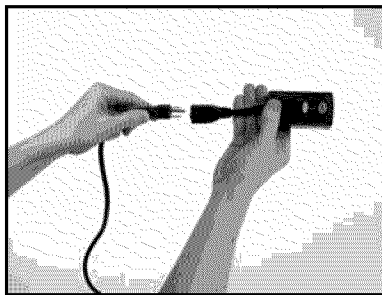

(B)

Verify all plugs fully installed. Check Ground Fault Circuit Interrupter.

NOTE: Verify circuit breaker at least 20 amps - if not, move to 20-amp circuit.
 Verify circuit breaker not tripped. If tripped, reset once.
 Check power source voltage is 120V - if not 120V, move to another circuit.

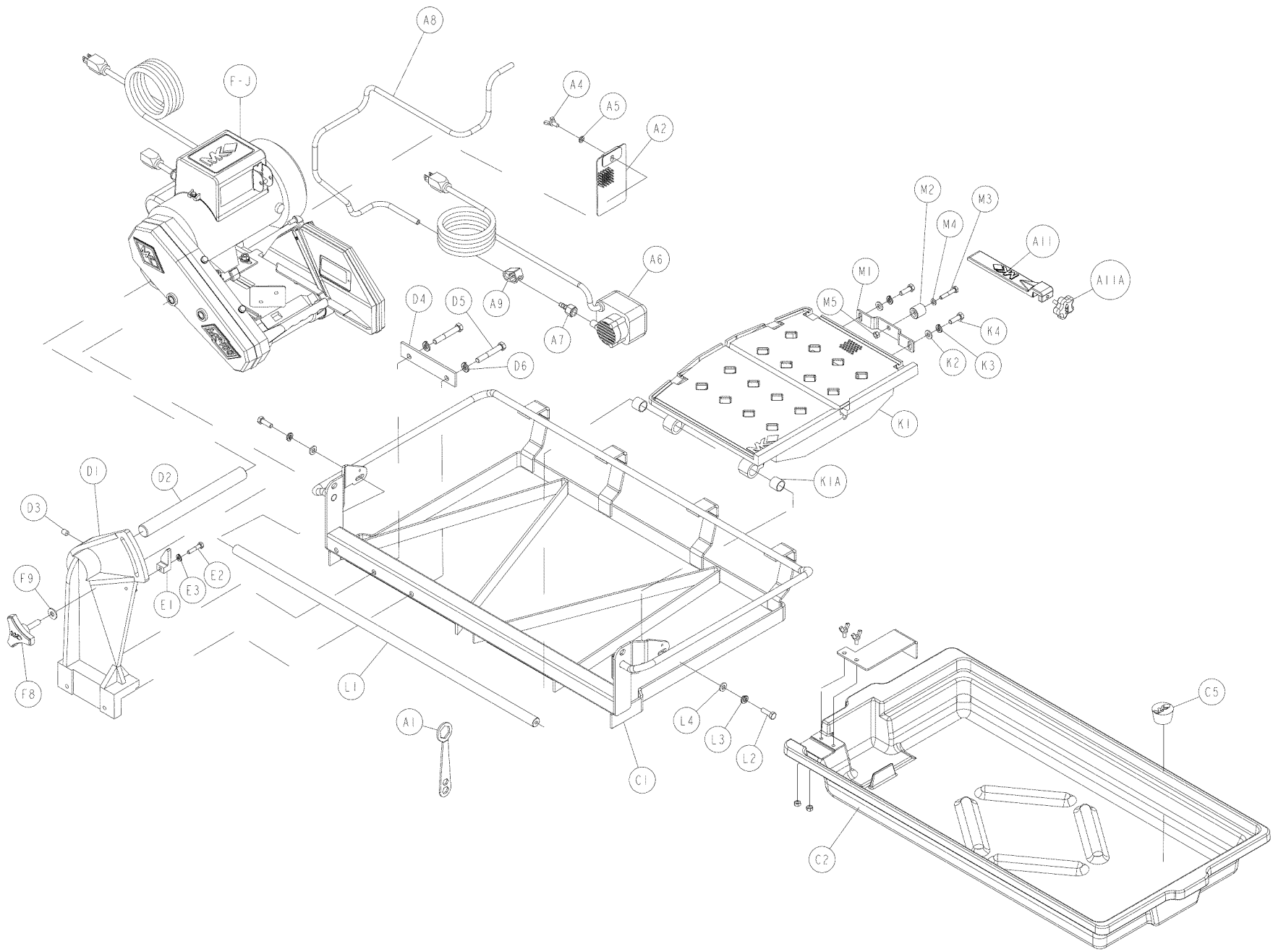

Item	Description	Qty	Part#
A	ACCESSORY PACK		N/A
A1	WRENCH, 15/16 CLOSED END	1	134684
A2	CURTAIN, SPLASH	1	160310
A3	BRACKET, SPLASH CURTAIN	1	152571
A4	WINGSCREW, 1/4 - 20 X 1/2	1	151888
A5	WASHER, 1/4 SAE FLAT	1	151915
A6	PUMP, 115V WATER	1	151271
A7	FITTING, PLASTIC, 1/4 FNPT X 1/4 BARB	1	128397
A8	HOSE, VINYL, 1/4 ID	2	132951
A9	CLAMP, FLOW, 1/4 - 1/2	1	154394
A10	OWNER'S MANUAL, WATER PUMP	1	155745
A11	RIP GUIDE	1	159751
A12	BLADE, MK-100, 10 X .060 X 5/8	1	154380
A13	OWNER'S MANUAL, MK-100	1	158192
A14	CARTON, ACCESSORY PACK, 101	1	153366
A15	FOAM, ACCESSORY PACK CARTON	1	154022
A16	CARD, MK WARRANTY REGISTRATION	1	155037
A17	LABEL, DO NOT RETURN	1	157063
B	CARTON		166621
B1	ASSEMBLY, CARTON, MK-100	1	160679
B2	COVER, CARTON, MK-100	1	160679-01
B3	TRAY, CARTON, MK-100	1	160679-02
B4	SUPPORT, CORNER, CARTON, MK-100	6	160679-03
B5	INSERT, CARTON, CUTTING HEAD	1	158542-1
B6	INSERT, CARTON, ACCESSORY PACK	1	158542-2
C-E	ASSEMBLY, FRAME		N/A
C1	FRAME, 101	1	153003
C2	PAN, PLASTIC, 101	1	150634
C3	PIN, 3/16 X 3/8 ROLL (NOT SHOWN)	2	151783
C4	PLATE, ADJUSTMENT OBSOLETE (NOT SHOWN)	2	151758
C5	PLUG, RUBBER DRAIN	1	159529
D	POST		N/A
D1	POST, DC, 101, MK RED	1	158438
D2	SHAFT, 10.63" PIVOT, 101	1	153254
D3	SCREW, 3/8 - 16 X 1/2 SCOKET HEAD SET	1	153710
D4	PLATE, SUPPORT	1	155671
D5	SCREW, 3/8 - 16 X 2-1/2	2	156030
D6	WASHER, 3/8 SPLIT LOCK	2	150925
D7	CASTING POST COVER, PLASTIC	1	160157
E	STOP, CUTTING HEAD		157728-MK
E1	STOP, 10" CUTTING HEAD	1	157728
E2	SCREW, 1/4 - 20 X 10 1/4 HEX HEAD CAP	1	157145
E3	WASHER, 1/4 SPLIT LOCK	1	152591
E4	SHEET, CUTTING HEAD STOP INSTRUCTION	1	157728-IS
F-J	ASSEMBLY, 115V CUTTING HEAD, MK-100	1	158225
F	BELT GUARD	1	N/A
F1	BELT GUARD, MK-100	1	158319-00
F2	BRACKET, INNER BELT GUARD	1	158611
F3	SCREW, 1/4 - 20 X 3/4 HEX HEAD CAP	3	152370
F4	SCREW, 1/4 - 20 X 1 HEX HEAD CAP	1	152676
F5	WASHER, 1/4 SPLIT LOCK	4	152591
F6	WASHER, 1/4 SAE FLAT	4	151915
F7	BELT, 260J6 MICRO-V	1	158194
F8	KNOB, 3/8 - 16 X 1.5 MK ADJUSTMENT	1	156770-2
F9	WASHER, 3/8 SAE FLAT	1	150923

Item	Description	Qty	Part#
G	BLADE GUARD		N/A
G1A	SCREW, HEX HEAD (NOT SHOWN)	1	162473
G1	BLADE GUARD, 110/115	1	162481
G2	ELBOW, 1/8 MNPT X 1/4 BARB 90° BRASS	1	154652
G3	TUBE, WATER	2	155389
G4	SCREW, 5/16 - 18 X 1/2 SOCKET HEAD SET	3	152607
G5	LABEL, TILE SAW SERIAL NUMBER	1	157249-01
H	SUBASSEMBLY, 115V CUTTING HEAD, MK-100	1	158191
H1	HEAD, 10" CUTTING	1	158224
H2	PIN, BLADE SHAFT LOCK	1	158220
H3	SPRING, BLADE GUARD LOCK	1	158201
H4	E-RING, 1/4 RETAINING	2	158202
H5	BEARING, 17MM X 40MM X 12MM BALL (6203 - 2NSSE)	2	137711
H6	SHAFT, BLADE 880/101/108-	1	158222
H7	FLANGE, 2 - 3/8 INNER	1	137737
H8	FLANGE, 2 - 3/8 OUTER	1	135830
H9	NUT, 5/8 18 HEX	1	135848
H10	PULLEY, 6J19 X 5/8 BORE	1	158199
H11	KEY, 3/6 X 3/16 X 1-1/8 WQUARE	1	150344
H12	SCREW, 5/16 - 18 X 3/8 SOCKET HEAD SET, CUP POINT	2	157083
H13	BUMPER, 1/2 DIA. RUBBER	1	152674
H14	SCREW, 5/16 -18 X 1 HEX HEAD CAP	4	151743
H15	WASHER, 5/16 SAE FLAT	4	151754
H16	WASHER, 5/16 SPLIT LOCK	4	151747
H17	NUT, 5/16 - 18 HEX	4	101196
H18	SCREW, 5/16 -18 X 2-1/2 HEX HEAD CAP, FULL THREAD	1	151748
H19	PIVOT, BLADE GUARD	1	153208
H20	WASHER, 3/8 SAE FLAT	2	150923
H21	WINGNUT, 5/16 - 18 NYLOCK	1	151746
H22	STRAP, MOTOR ADJUSTMENT	1	152673
H23	SCREW, 3/8 - 16 X 3 - 1/2 HEX HEAD FULL THREAD	1	153174
J	ASSEMBLY, 1/5HP/115V/60HZ GE MOTOR		N/A
J1	MOTOR, 1/5HP/115V/60HZ GE	1	168022
J2	CASTING, CONDUIT BOX	1	168969
J3	GASKET, CONDUIT BOX/MOTOR	1	158213
J4	SCREW, #12 X 5/8 INDENTEDHEX WASHER SLOTTED B	2	158335
J5	CORD, 14/3 SJTW X 5 - 15P X POWER	1	158205
J6	CORD, 18/3 SJTW X 5 - 15R PUMP	1	158253
J7	SWITCH, 20A DPST TOGGLE, W/QD TERMINALS	1	154310
J8	PLATE, TOGGLE SWITCH LOCKOUT	1	158211
J9	BOOT, TOGGLE SWITCH	1	154301
J10	PULLEY, 6J17 X 5/8 BORE	1	158214
J11	KEY, 3/16 X 3/16 X 1 - 1/8 SQUARE	1	150344
J12	SCREW, 5/16 - 18 X 3/8 SOCKET HEAD SET, CUP POINT	2	157083
J13	LABEL, WARNING, READ OWNER'S MANUAL, 1 - 3/4 X 3 - 3/8	1	155806
J14	LABEL, CAUTION, GFCI, 1 X 2 - 1/8	1	155678
J15	LABEL, CAUTION, 5 AMP MAX, 1 X 2 - 1/8	1	154822
J16	LABEL, MK SERVICE INFORM 2 1/8 X 1 - 13/16	1	155038
J17	SCREW, 10 - 32 X 1 SOCKET HEAD SET, CUP POINT	1	158254
J18	WASHER, #10 INTERNAL TOOTH LOCK	2	158336
J19	TIE, 12 X #10 CLAMP	1	158210
J20	SCREW, 10 - 32 X 1 SOCKET HEAD SET, CUP POINT	2	157083
J21	NUT, 10 - 32 HEX	2	156269
J22	WASHER, 1/2 INTERNAL TOOTH LOCK	1	158337
J23	CAPACITOR, RUN	1	160528
J24	CAPACITOR, START	1	164131
J25	SWITCH, OVERLOAD PROTECTION	1	168105

Item	Description	Qty	Part#
K-M	ASSEMBLY, TABLE		
K	TABLE		
K1	TABLE, 100	1	157660
K1A	BEARING, 3/4 ID MULTILUBE	2	152227
K2	WASHER, 5/16 SAE FLAT	2	151754
K3	WASHER, 5/16 SPLIT LOCK	2	151747
K4	SCREW, 5/16 - 18 X 1 HEX HEAD CAP	2	151743
L	GUIDE BAR		N/A
L1	BAR, 3/4 X 32 GUIDE, 101	1	134759
L2	SCREW, 5/16 - 18 X 1 HEX HEAD CAP	2	151743
L3	WASHER, 5/16 SPLIT LOCK	2	151747
L4	WASHER, 5/16 SAE FLAT	2	151754
M	ASSEMBLY, ROLLER WHEEL		151756
M1	BRACKET, ROLLER WHEEL	1	154021
M2	WHEEL, ROLLER	1	151799
M3	SCREW, 14/ - 20 X 1 - 1/2 HEX HEAD CAP	1	151914
M4	WASHER, 1/4 SAE FLAT	1	151915
M5	NUT, 1/4 - 20 HEX	1	151893

THEORY OF DIAMOND BLADES

Diamond blades do not really cut; they grind the material through friction. Diamond crystals, often visible at the leading edge and sides of the rim/segment, remove material by scratching out particles of hard, dense materials, or by knocking out larger particles of loosely bonded abrasive material. This process eventually cracks or fractures the diamond particle, breaking it down into smaller pieces. As a result, a diamond blade for cutting soft, abrasive material must have a hard metal matrix composition to resist this erosion long enough for the exposed diamonds to be properly utilized. Conversely, a blade for cutting a hard, non-abrasive material must have a soft bond to ensure that it will erode and expose the diamonds embedded in the matrix. These simple principles are the foundation of “controlled bond erosion”

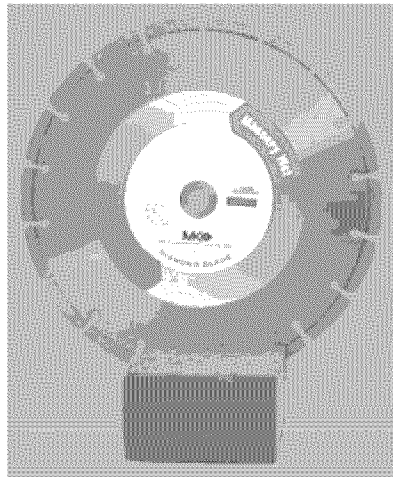

Types of Cutting







There are two basic types of cutting-Dry or Wet. The choice of which type of blade to use depends on:

- The requirements of the job
- The machine/tool utilizing the Diamond Blade
- The preference of the operator

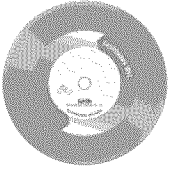
In the case of DRY cutting, the overwhelming popularity and quantity of hand-held saws and the flexible nature of MK Diamond blades to professionally handle most ceramic, masonry, stone and concrete materials, make the DRY cutting blade a very attractive tool. When using a DRY blade, the user must be aware of distinct operating practices to ensure optimum performance. DRY cutting blades require sufficient airflow about the blade to prevent overheating of the steel core. This is best accomplished by shallow, intermittent cuts of the material with periods of “free-spinning” (for several seconds) between each cut, to maximize the cooling process.

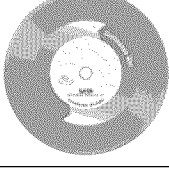
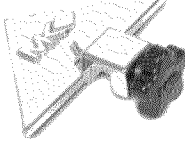
For WET cutting applications, MK has the exact blade to compliment both the material to be cut and the wet cutting machine to be used. During cutting operations, liberal amounts of water act as a coolant to support the cutting effectiveness and longevity of the WET blade. Additionally, using water adds to the overall safety of cutting operations by keeping the dust signature down.

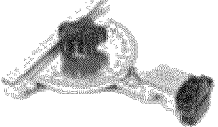
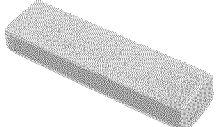
KNOW ALL YOU CAN ABOUT THE MATERIAL YOU WISH TO CUT

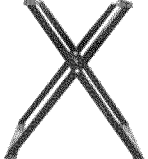
ITEM	NUMBER	DESCRIPTION	
1.	137166	MK-200, 10 x 5/8 Arbor Premium grade Diamond Blade for smooth, chip-free cutting on tile.	
2.	128074	MK-215, 10 x 5/8 Arbor Supreme grade diamond blade for hard materials	
3.	153252	MK-315, 10 x 5/8 Arbor Supreme super hi-rim diamond blade	
4.	134577-MK	Dual 45° Flat Angle Guide	
5.	153201-MK (large)	45° Bullnose Miter	
6.	134569-MK	90° Protractor	
7.	152792	Dressing Stone	
8.	152610	Ground Fault Circuit Interrupter	
9.	151889	Stand for 10" Tile Saw	

ORDERING INFORMATION

You may order MK Diamond products through your local MK Diamond distributor or, you may order direct from MK Diamond.

NOTE: There is a \$25.00 minimum order when ordering direct from MK Diamond. All purchases must be made using VISA, MasterCard or American Express.

When ordering direct from MK Diamond, please have the following information ready before calling:

- The Model Number of the saw
- The Serial Number of the saw
- Where the saw was purchased and when
- The Part Number for the part(s) being ordered
- The Part Description for the part(s) being ordered

All parts may be ordered by calling toll free to – (800) 421-5830 or (310) 539-5221 and asking for Customer Service. For technical questions, call – (800) 474-5594.

RETURN MATERIALS POLICY

To expedite the service relative to the return of a product purchased through MK Diamond, please observe the following:

NOTE: When returning all items, they must have been purchased within the previous twelve (12) months.

- Have the Model Number of the saw
- Have the Serial Number of the saw
- Have the location of where the saw was purchased
- Have the date when the saw was purchased
- Contact Customer Service for approval to return the item(s)
- Obtain a Returned Goods Number (RGA) authorizing the return
- Follow the packaging instructions in the following section
- Ensure your item(s) are prepaid to the destination

For returned items, call toll free to – (800) 421-5830 or (310) 539-5221 and ask for Customer Service. For technical questions, call – (800) 474-5594 or (310) 257-2845.

PACKAGING INSTRUCTIONS

- Remove the Blade guard and Support Angle Assembly
- Dry the saw before shipping
- When packing, include the following: MK-100, Diamond Blade, Blade guard and Support Angle Assembly and Adjustable Cutting Guide (Other Accessories are not required)
- Package the unit in its original container or one of comparable size (do not ship the unit partially exposed)
- Ensure all parts are secured in the packaging to prevent moving

AUTHORIZED SERVICE CENTERS

For quicker repair time, you may contact MK Diamond Customer Service, toll free, at (800) 421-5830 or (310) 539-5221 for the Authorized Service Center closest to you or visit our web site at www.mkdiamond.com. For technical questions, call – (800) 474-5594.

MK-100 TILE SAW
OWNER'S MANUAL & OPERATING INSTRUCTIONS



MK Diamond Products, Inc.

MK Diamond Products, Inc.
1315 Storm Parkway
Torrance, CA 90501

Toll-Free: (800) 421-5830
Phone: (310) 539-5221
Fax: (310) 539-5158
www.mkdiamond.com