

# Operator's Manual

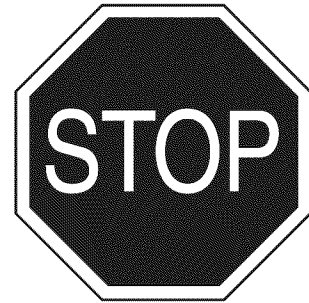

## CHIP-N-VAC

Model No's. 486.25013

DO NOT RETURN TO STORE  
For Missing Parts or Assembly  
Questions Call 1-866-576-8388

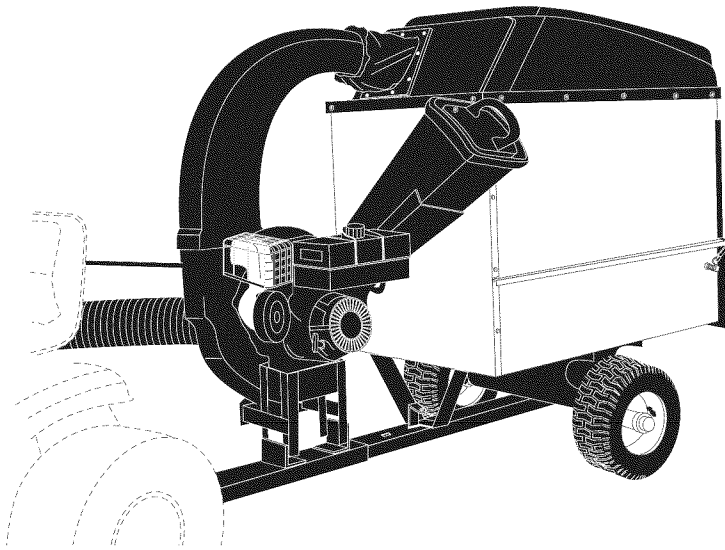

**IMPORTANT:** The engine is shipped without oil. Add oil before starting the engine.

**IMPORTANT:** The wheel bearings are not pre-lubricated.  
Fill the wheel hubs with grease after assembling the wheels to the axle.

### CAUTION:

Before using this product, read this manual and follow all Safety Rules and Operating Instructions.

- Safety
- Assembly
- Operation
- Maintenance
- Parts

Sears, Roebuck and Co., Hoffman Estates, IL 60179 U.S.A.  
[www.sears.com/craftsman](http://www.sears.com/craftsman)

# TABLE OF CONTENTS

WARRANTY .....	2	SERVICE AND ADJUSTMENTS .....	19
SAFETY RULES .....	3	STORAGE .....	19
FULL SIZE HARDWARE CHART .....	6	TROUBLESHOOTING .....	20
CARTON CONTENTS .....	7	REPAIR PARTS ILLUSTRATIONS .....	23,24,26
ASSEMBLY .....	8	REPAIR PARTS LISTS .....	23,25,26
OPERATION .....	16	SLOPE GUIDE .....	27
MAINTENANCE .....	18	PARTS ORDERING/SERVICE .....	Rear Cover

## WARRANTY

### CRAFTSMAN FULL WARRANTY

FOR ONE YEAR from the date of purchase, this product is warranted against defects in material or workmanship. A defective product will receive free in-home repair or replacement if repair is unavailable.

### WARRANTY SERVICE

For warranty coverage details to obtain free repair or replacement, call 1-800-659-5917 or visit the web site: [www.craftsman.com](http://www.craftsman.com)

All of the above warranty coverage is void if this riding equipment is ever used while providing commercial services or if rented to another person.

### **This warranty covers ONLY defects in material and workmanship. Warranty coverage does NOT include:**

- Expendable parts that can wear out from normal use within the warranty period, including but not limited to spark plugs, air cleaners, belts, and oil filters.
- Standard maintenance servicing, oil changes, or tune-ups.
- Tire replacement or repair caused by punctures from outside objects, such as nails, thorns, stumps, or glass.
- Tire or wheel replacement or repair resulting from normal wear, accident, or improper operation or maintenance.
- Repairs necessary because of operator abuse, including but not limited to damage caused impacting objects that bend the frame, axle assembly or crankshaft, or over-speeding the engine.
- Repairs necessary because of operator negligence, including but not limited to, electrical and mechanical damage caused by improper storage, failure to use the proper grade and amount of engine oil, failure to keep the product clear of flammable debris, or failure to maintain the equipment according to the instructions contained in the operator's manual.
- Engine (fuel system) cleaning or repairs caused by fuel determined to be contaminated or oxidized (stale). In general, fuel should be used within 30 days of its purchase date.
- Normal deterioration and wear of the exterior finishes, or product label replacement.

This warranty gives you specific legal rights, and you may also have other rights which vary from state to state.

Sears Brands Management Corporation, Hoffman Estates, IL 60179

<p>The model and serial numbers will be found on a decal attached to the engine base.</p> <p>You should record both the serial number and the date of purchase and keep in a safe place for future reference.</p>	<table style="width: 100%; border: none;"> <tr> <td style="width: 60%;">MODEL NUMBER:</td> <td style="width: 40%;">486.25013</td> </tr> <tr> <td>SERIAL NUMBER:</td> <td>_____</td> </tr> <tr> <td>DATE OF PURCHASE:</td> <td>_____</td> </tr> </table>	MODEL NUMBER:	486.25013	SERIAL NUMBER:	_____	DATE OF PURCHASE:	_____
MODEL NUMBER:	486.25013						
SERIAL NUMBER:	_____						
DATE OF PURCHASE:	_____						



## SAFETY



Any power equipment can cause injury if operated improperly or if the user does not understand how to operate the equipment. Exercise caution at all times, when using power equipment.

- Read and follow all instructions in this manual before attempting to assemble or operate this equipment. Failure to comply with these instructions may result in personal injury. Keep this manual in a safe place for future reference and for ordering replacement parts.
- Read this operating and service instruction manual carefully. Be thoroughly familiar with the controls and proper use of this power vacuum.
- Read the vehicle owners manual and vehicle safe operation rules before using this equipment.
- Never allow children under 16 to operate this Chipper Vac. Children 16 years and older should only operate under close parental supervision.
- Do not allow anyone to operate this equipment without proper instructions.
- Do not allow passengers to ride on this equipment or on the towing vehicle.
- Keep the area of operation clear of all persons, particularly small children. Also keep area clear of pets.
- Check fuel before starting engine. Do not fill fuel tank indoors, or when engine is running, or while engine is hot. Wipe off any spilled fuel before starting engine.
- Engine and muffler get hot. Do not touch! To avoid fire hazard, keep clean of debris and other accumulations.
- Never store Chipper Vac with fuel in tank. Allow engine to cool before storing in any enclosure.
- Do not change engine governor settings.
- Do not operate engine if air cleaner or cover is removed, except for adjustment. Removal of these parts could create a fire hazard.
- Before cleaning, repairing or inspecting, make certain all moving parts come to a complete stop. Disconnect spark plug wire and keep wire away from plug to prevent accidental starting. Keep throttle control lever in stop position.
- If the Chipper Vac should become blocked with debris at any point, shut engine off and wait until the impeller comes to a complete stop before attempting to remove the obstruction. Disconnect spark plug wire to prevent accidental starting.
- If the cutting mechanism strikes a foreign object, or if your Chipper Vac should start to vibrate abnormally, stop the engine immediately, disconnect the spark plug wire and move the wire away from the spark plug. Allow the machine to stop and take the following steps.
  - a. Inspect for damage.
  - b. Repair or replace any damaged parts.
  - c. Check for loose parts and tighten to assure continued safe operation.
- Check all bolts for tightness at frequent intervals to help insure safe operation.
- Check vinyl hard top boot frequently for wear. Replace if worn or damaged.
- Never operate Chipper Vac unless deck adapter, hose, hose adapter (nozzle), discharge chute (elbow), chipper chute and top cover are properly attached in their place.
- Do not remove top cover or attempt to empty contents of cart while engine is running.
- Never attempt to change hose adapter (nozzle) or to install remote hose attachment when engine is running.
- Keep all shields and guards (e.g. chipper chute, discharge chute (elbow) and hose adapter (nozzle) in place and securely attached.
- Keep hands, feet, face, long hair and clothing out of inlet and discharge area. There are ROTATING BLADES inside these openings.
- Always wear safety glasses or other suitable eye protection when operating or maintaining this equipment.
- Wear protective gloves when feeding material into the chipper chute. Avoid loose fitting clothing.
- Keep face and body clear of the chipper chute to avoid accidental bounce back of any material.
- When feeding material into this equipment, be extremely careful that pieces of metal, rocks, bottles, cans or other foreign objects are not included. Personal injury or damage to the machine could result.
- Do not stand behind cart in exhaust discharge area while engine is running.
- Do not operate this equipment while intoxicated or while taking drugs or medication that impairs the senses and reactions.
- When using this equipment, start with the vehicle transmission in first (low) gear and then gradually increase speed only as conditions permit.
- Operate this equipment at reduced speed on rough terrain, along creeks and ditches and on slopes to prevent tipping or loss of control. Do not drive too close to a creek or ditch.
- Vehicle braking and stability are affected by the addition of this equipment. Do not fill the Chipper Vac to its full capacity without checking the capability of the towing vehicle to safely pull and stop with the Chipper Vac attached.
- Before operating on any grade (hill) refer to the safety rules in the vehicle owner's manual concerning safe operation on slopes. Also refer to the SLOPE GUIDE on page 27 of this owner's manual. Do not operate on slopes in excess of 10 degrees. STAY OFF STEEP SLOPES.
- Follow the maintenance instructions outlined in this manual.



Look for this symbol to point out important safety precautions. It means — **Attention!! Become alert!! Your safety is involved.**



**DANGER:** This Chipper Vac was built to be operated according to the rules for safe operation in this manual. As with any type of power equipment, carelessness or error on the part of the operator can result in serious injury. This unit is capable of amputating fingers and hands and throwing objects. Failure to observe the following safety instructions could result in serious injury or death.

# **WARNING**

## **TO AVOID SERIOUS INJURY**

- Read Owner's Manual and all safety labels on machine before starting and using machine.
- Do Not remove top cover or attempt to empty contents of cart while engine is running.
- Do Not stand behind cart in exhaust discharge area while engine is running.
- Keep hands, feet, face, long hair and clothing out of chipper inlet, vac inlet, and discharge area. There are **ROTATING BLADES** inside these openings.
- Wear approved safety glasses and gloves. Avoid loose fitting clothes.
- Keep the area of operation clear of all persons, particularly small children and pets.
- Keep all shields and guards (e.g. upper chipper chute extension, discharge chute, nozzle assembly) in place and securely attached.
- Check discharge boot frequently for wear. Replace if worn or damaged.
- If unit becomes clogged or jammed, shut off engine right away. Do Not attempt to clear clog or jam with engine running.
- Muffler and engine get hot and can cause burns. Do Not Touch. To avoid a fire hazard, keep leaves, grass and other combustible debris off hot muffler and engine.
- Do Not attempt to remove or attach vac nozzle or optional Hose Kit with engine running.
- Do Not operate unit unless nozzle or optional Hose Kit is secured in place.
- Do Not fill gas tank while engine is running. Allow engine to cool at least 2 minutes before refueling.



## **DANGER**

**ROTATING CUTTING BLADES.  
KEEP HANDS AND FEET OUT  
OF OPENINGS WHILE MACHINE  
IS RUNNING.**



## **WARNING**

**MUFFLER & ADJACENT AREAS  
MAY EXCEED 150 ° F**



## **DANGER**

**HAZARDOUS ROTATING BLADES INSIDE. KEEP HANDS AWAY FROM ALL  
OPENINGS. DO NOT REMOVE OR ATTACH HOSE, HOSE ADAPTER, ELBOW OR  
OPTIONAL HOSE KIT WHEN ENGINE IS RUNNING!**



## **WARNING**

This unit is equipped with an internal combustion engine and should not be used on or near unimproved forest-covered, or grass-covered land unless the engine's exhaust system is equipped with a spark arrester meeting applicable local or state laws (if any). If a spark arrester is used, it should be maintained in effective working order by the operator.

In the State of California the above is required by law (Section 4442 of the California Public Resources Code). Other states may have similar laws. Federal laws apply on federal lands. A spark arrester muffler is available at your nearest engine authorized service center.

## ACCESSORIES AND ATTACHMENTS

These accessories were available when the unit was purchased. They are also available at most Sears retail outlets and service centers. Most Sears stores can order repair parts for you when you provide the model numbers of your tractor and Chipper Vac System.

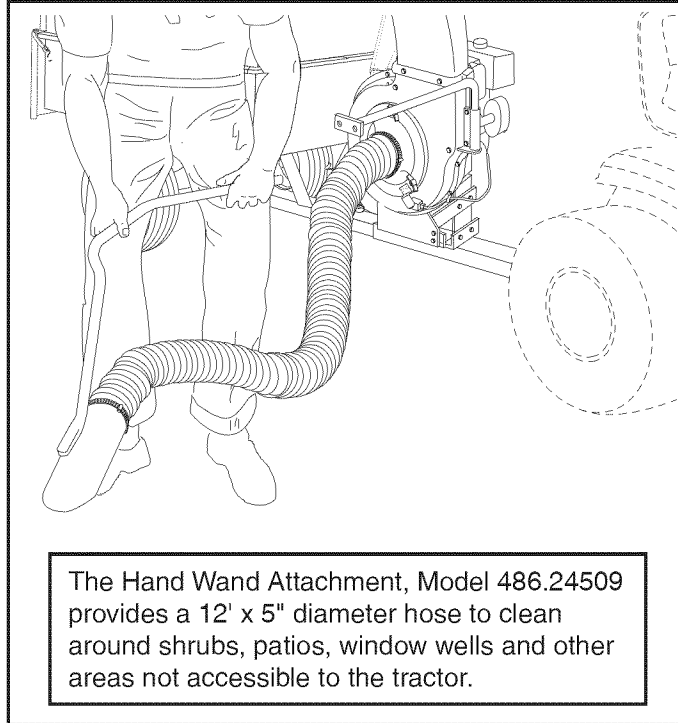

# HARDWARE PACKAGE CONTENTS

## SHOWN FULL SIZE

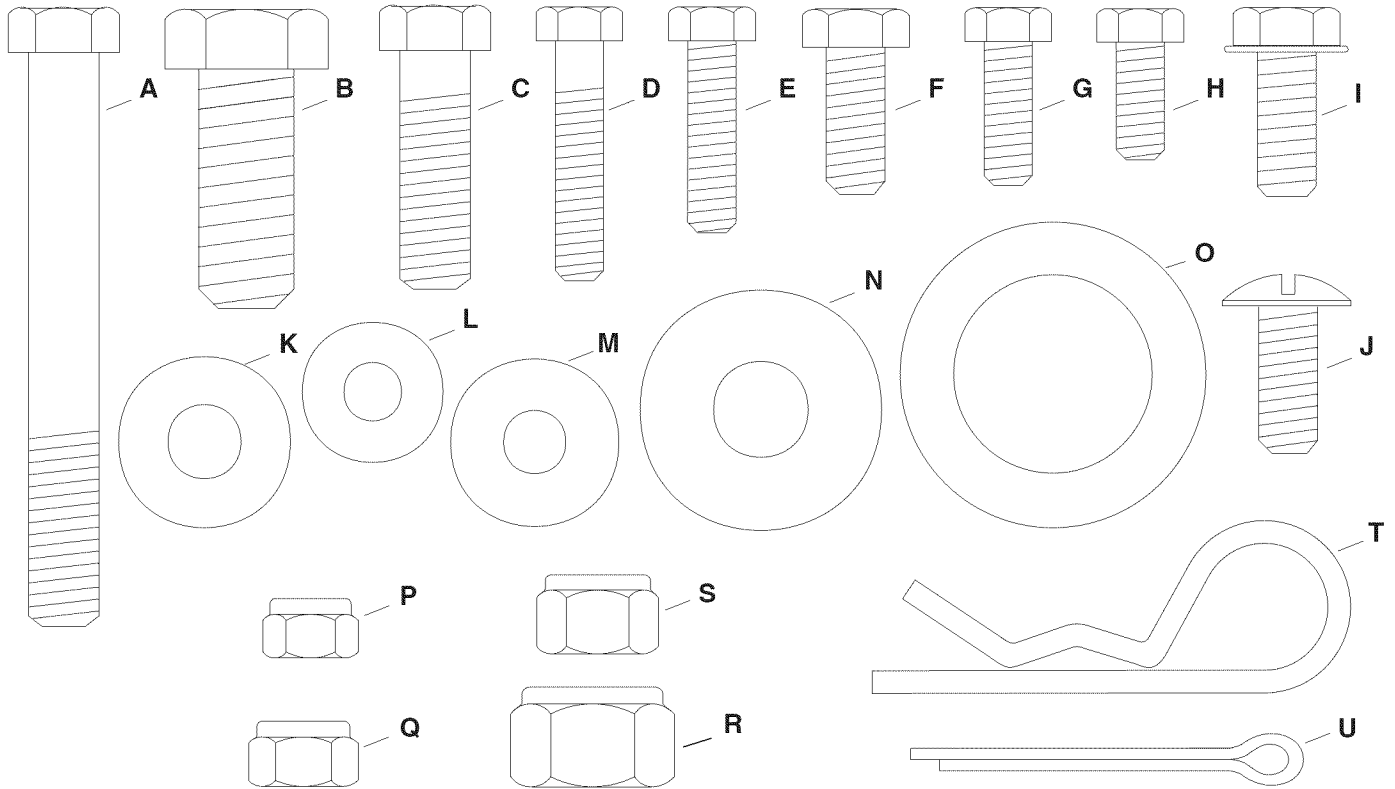

## NOT SHOWN FULL SIZE

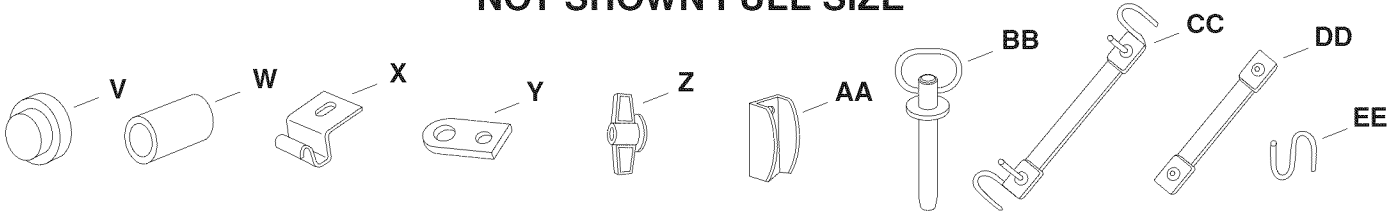

See page 14 for the Deck Adapter hardware package. (Contents not included here.)

REF.	PART NO.	QTY		DESCRIPTION	REF.	PART NO.	QTY		DESCRIPTION
		CART	VAC				CART	VAC	
A	43574	3	—	Hex Bolt, 3/8" x 3"	Q	47810	12	9	Nylock Nut, 5/16"
B	43351	—	1	Hex Bolt, 1/2" x 1-1/4"	R	712-3083	—	1	Nylock Nut, 1/2"
C	43087	2	—	Hex Bolt, 3/8" x 1-1/4"	S	HA21362	5	—	Nylock Nut, 3/8"
D	1509-90	—	5	Hex Bolt, 1/4" x 1-1/4"	T	43343	1	—	Hair Cotter Pin, 1/8"
E	43661	—	2	Hex Bolt, 1/4" x 1"	U	43093	2	—	Cotter Pin, 1/8" x 1-1/2"
F	43182	—	6	Hex Bolt, 5/16" x 3/4"	V	43014	2	—	Hub Cap
G	43012	—	14	Hex Bolt, 1/4" x 3/4"	W	44678	2	—	Spacer Tube
H	43866	9	20	Hex Bolt, 1/4" x 5/8"	X	23838	2	—	Door Support
I	47630	—	4	Hex Bolt, 5/16" x 3/4" Thd. Forming	Y	23540	—	1	Hitch Plate
J	43814	12	—	Truss Head Bolt, 5/16" x 3/4"	Z	712-0421	—	3	Knob
K	1543-69	—	6	Nylon Washer	AA	23789	—	2	Door Latch
L	43088	2	36	Flat Washer, 1/4"	BB	43884	1	—	Hitch Pin
M	43081	—	3	Flat Washer, 5/16"	CC	43790	—	1	Tarp Strap, 25"
N	43352	—	1	Flat Washer, 7/16"	DD	44850	—	4	Tarp Strap (Less Hooks)
O	43601	4	—	Flat Washer, 1"	EE	44849	—	4	"S" Hooks
P	47189	9	40	Nylock Nut, 1/4"					

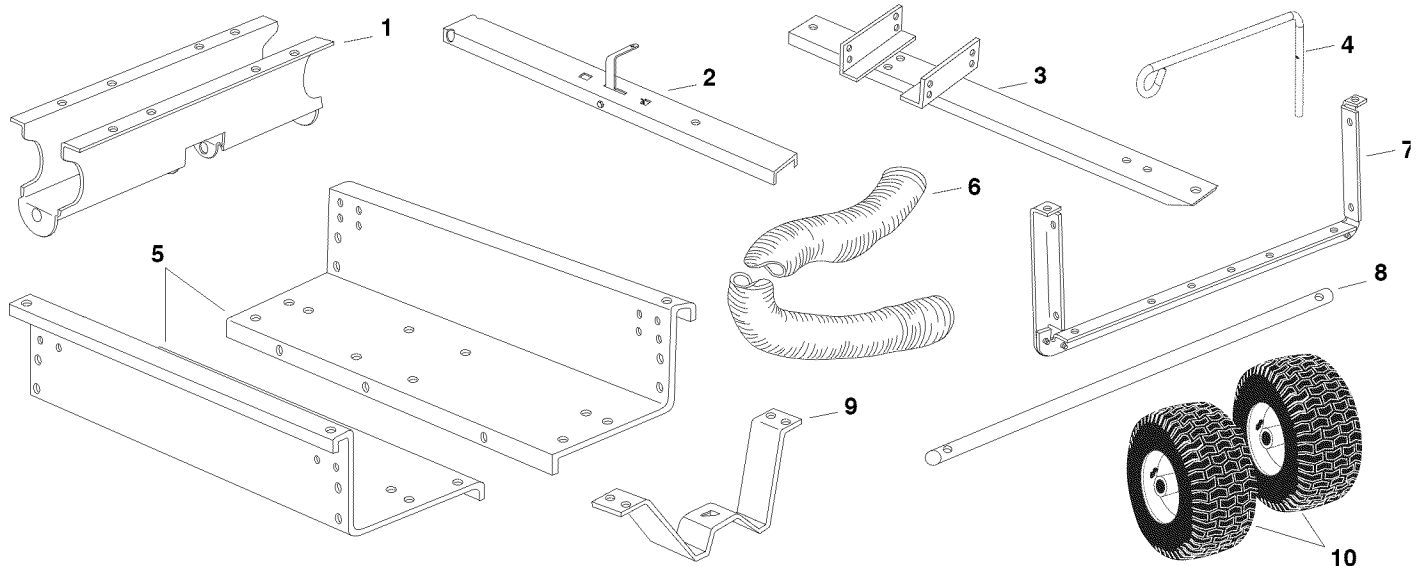

**CARTON CONTENTS (Cart Body Carton)**

REF.	PART NO.	QTY	DESCRIPTION	REF.	PART NO.	QTY	DESCRIPTION
1	23507	1	Wheel Support	6	41882	1	Hose
2	63917	1	Rear Tongue	7	62458	1	Tailgate Reinforcement Bracket
3	63155	1	Front Tongue	8	24897	1	Axle
4	49974	1	Hose Hanger Rod	9	24497	1	Latch Stand Bracket
5	23985	2	Cart Body	10	42159	2	Wheels

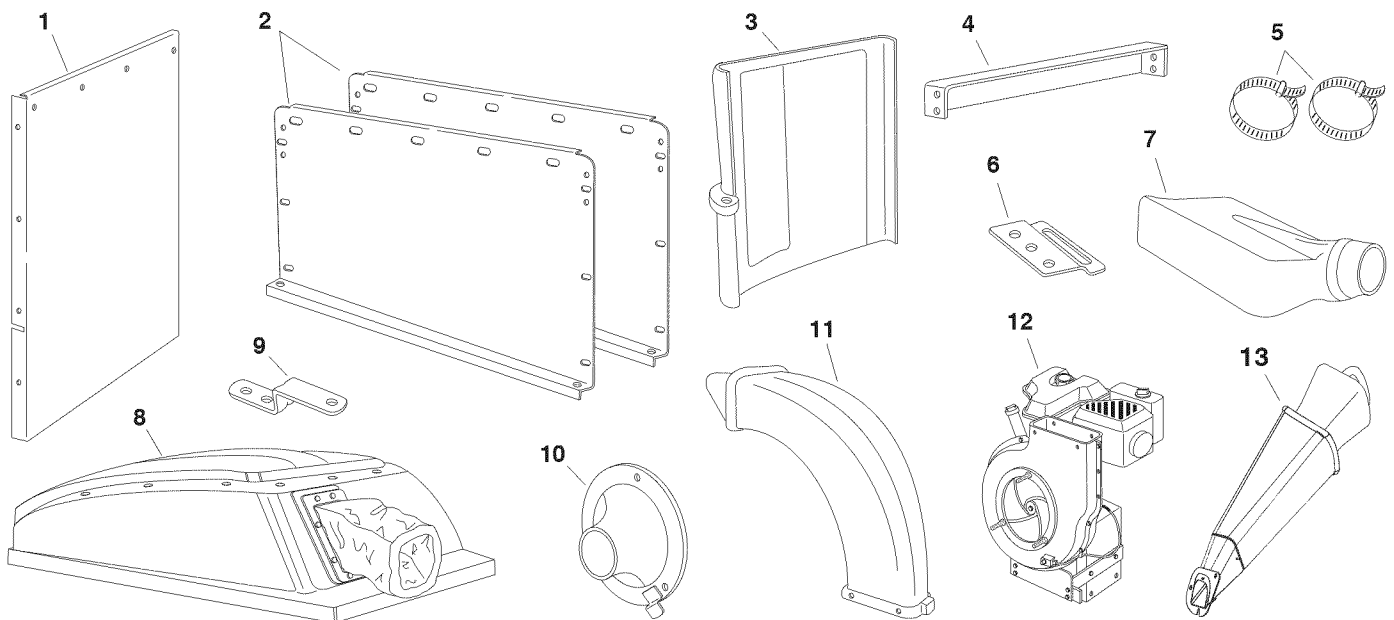

**CARTON CONTENTS (Mow-N-Vac Carton)**

REF.	QTY	DESCRIPTION	REF.	QTY	DESCRIPTION		
1	24679	1	Front Panel	8	64244	1	Poly Hard Top
2	24678	2	Side Panels	9	23475	1	Hitch Bracket
3	44790	1	Rear Door	10	43791	1	Hose Adapter (Nozzle)
4	23836	1	Cross Brace	11	46420	1	Elbow
5	43793	2	Hose Clamp	12	N/A	1	Engine w/Base Assembly
6	23560	1	Adapter Bracket	13	63376	1	Chipper Chute
7	43830	1	Deck Adapter	14	731-1617	1	Tamper Plug

# ASSEMBLY

This unit is shipped WITHOUT GASOLINE or OIL. After assembly, see separate engine manual for proper fuel and engine oil recommendations.

## TOOLS REQUIRED FOR ASSEMBLY

- (1) Screwdriver
- (1) Pliers
- (2) 7/16" Wrenches
- (2) 1/2" Wrench
- (2) 9/16" Wrenches
- (2) 3/4" Wrenches (only if figure 23 on page 12 is used)

## REMOVAL OF PARTS FROM CARTONS

- Remove the hardware packs and all loose parts from the cartons.
- Lay out and identify parts shown in carton contents.
- Lay out and identify parts in the hardware packs. Keep contents of each hardware package separate.

## ASSEMBLING THE CART BODY

- Place cart body halves upright on a smooth level surface such as a garage floor or a paved driveway. See figure 1.



**CAUTION:** Do not leave the cart unattended in upright position during assembly. A falling cart can cause personal injury! Pay close attention to the stability of the cart while it remains in an upright position. For best stability, assemble on a smooth level surface.

- Assemble cart body halves together using three 1/4" x 5/8" hex bolts and 1/4" nylock nuts as shown in figure 1. **Do not tighten yet.**

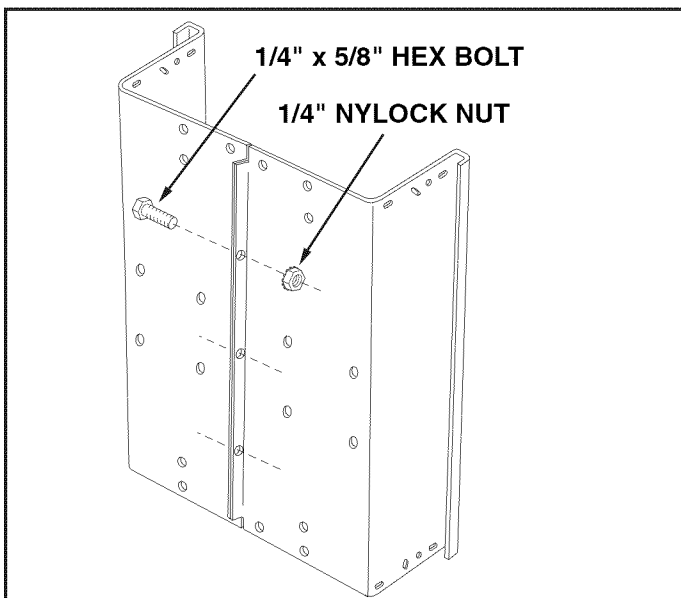

FIGURE 1

- Fit the tailgate reinforcement bracket over the end of the cart bed. Position the two door support brackets on the bottom of the reinforcement bracket as shown in figure 2. Fasten the reinforcement bracket and the door supports to the bottom of the cart using four 5/16" x 3/4" truss head bolts and 5/16" nylock nuts. **Do not tighten yet.** See figure 2.
- Fasten the tailgate reinforcement bracket to the sides of the cart body using four 1/4" x 5/8" hex bolts and 1/4" nylock nuts as shown in figure 2. **Do not tighten yet.**

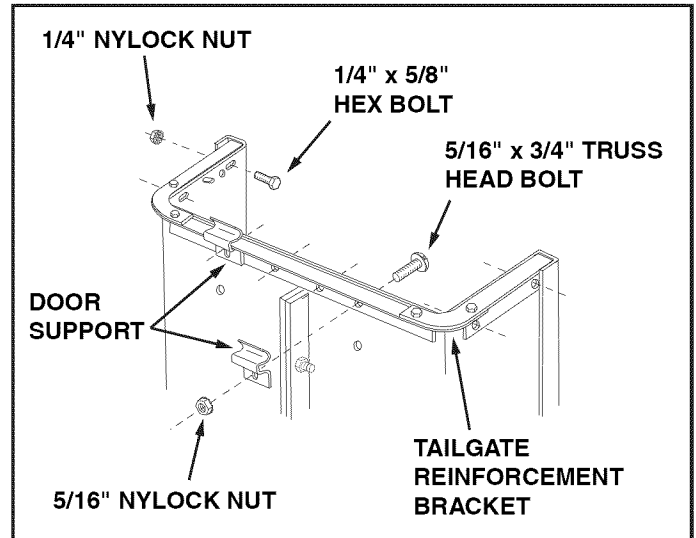

FIGURE 2

- Pull the cart body halves together. **Tighten** the four truss head bolts in figure 2. **Tighten** the four hex bolts in figure 2. **Tighten** the three hex bolts in figure 1, keeping the bottom aligned and pulled together.
- Carefully flip the cart end for end so that it rests on the tailgate reinforcement bracket. See figure 3.

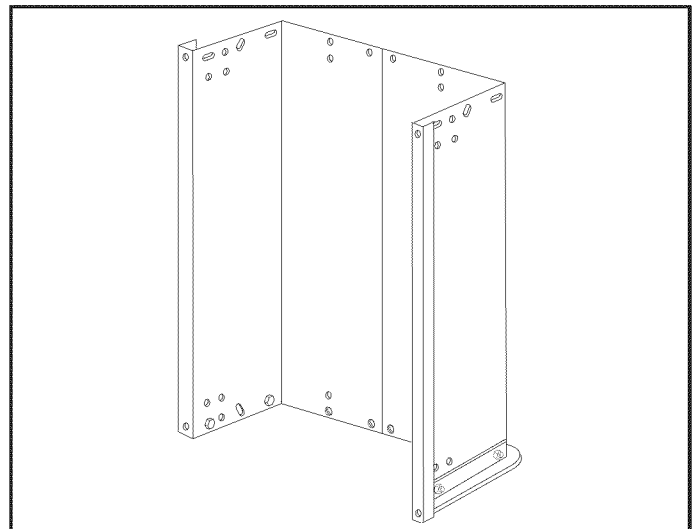

FIGURE 3



- Assemble the wheel support to the bottom of the cart using eight 5/16" x 3/4" truss head bolts and 5/16" nylock nuts as shown in figure 4. Heads of bolts go on the inside of cart. **Tighten.**

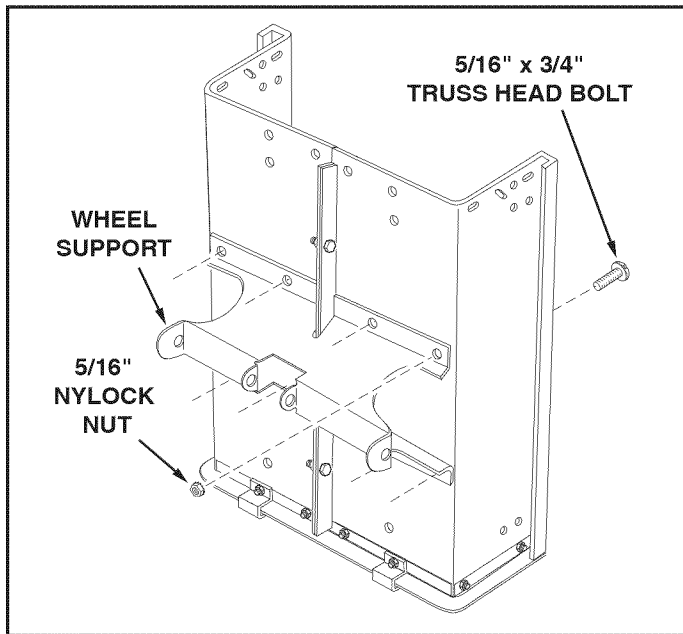

FIGURE 4

- To prevent accidental tipping during the following assembly procedures, lower the cart to rest upside down, with the wheel support facing up, as shown in figure 5.
- Align the latch stand bracket so that the tab is at the rear. Fasten the bracket to the rear set of holes at the front of the cart using two 1/4" x 5/8" hex bolts, 1/4" flat washers and 1/4" nylock nuts. Use the 1/4" flat washers as shims between the bracket and the cart bed. **Make finger tight.** See figure 5.

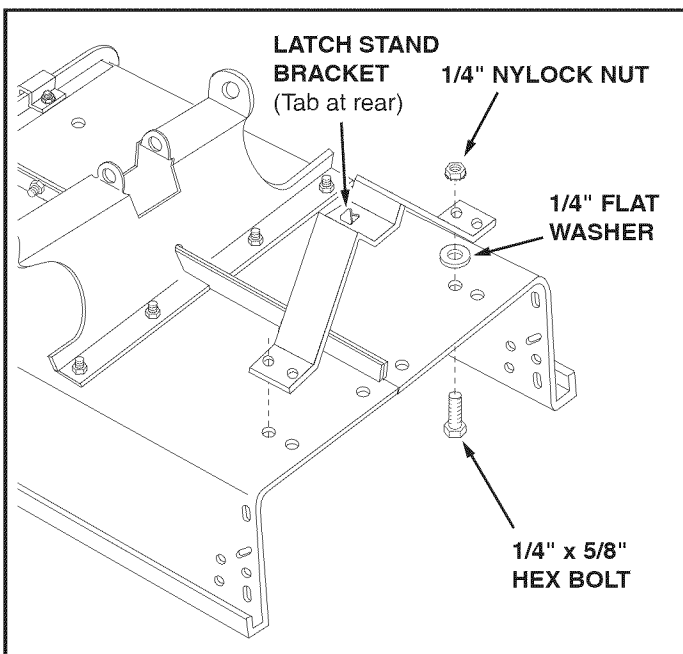

FIGURE 5

- Position the rear tongue on the wheel support and the latch stand bracket. Assemble the axle through the wheel support and the tongue. See figure 6.

**IMPORTANT:** Make sure the tongue is securely locked to the latch stand bracket by the latch lock lever.

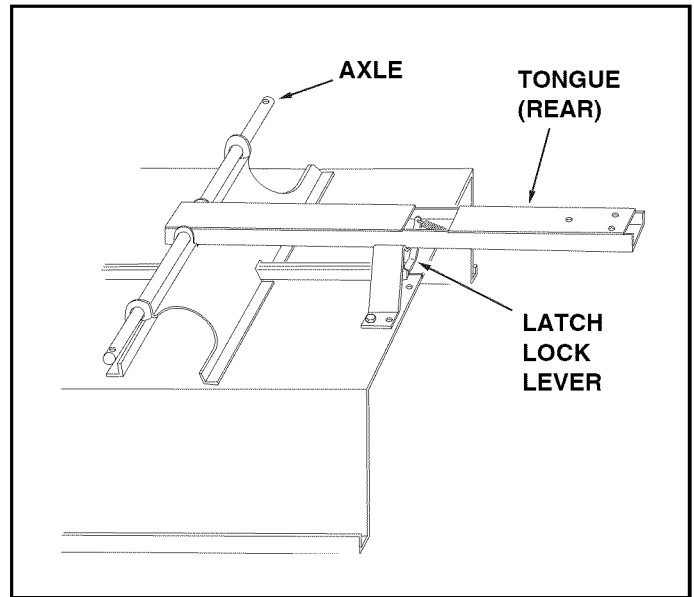

FIGURE 6

- Assemble a spacer tube, a 1" flat washer, a wheel (valve stem facing out), and another 1" flat washer onto the axle as shown in figure 7. Secure the wheel with a cotter pin, spreading the ends so that a hub cap can fit over the pin. Assemble the hub cap by pressing it onto the flat washer. Repeat on other end of axle.
- Pump grease into grease fittings on wheels until grease is forced out through ends of hubs.

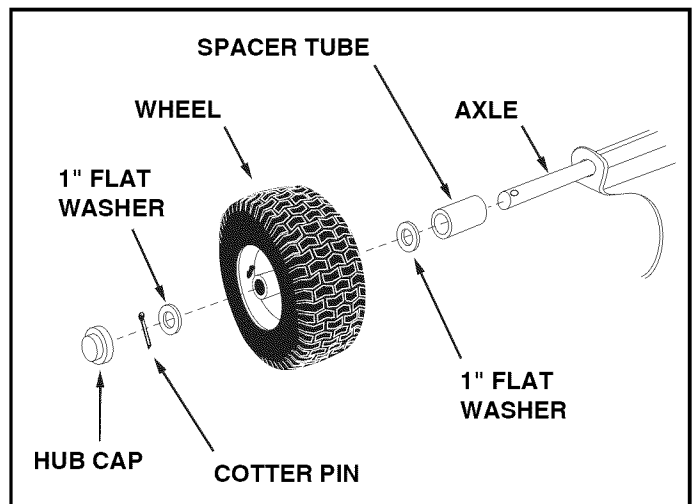

FIGURE 7

- Flip the cart over so that it rests on its wheels.
- Assemble the front tongue on top of the rear tongue using three 3/8" x 3" hex bolts and 3/8" nylock nuts. See figure 8.

**HINT:** For easier assembly, support the rear tongue with a block of wood.

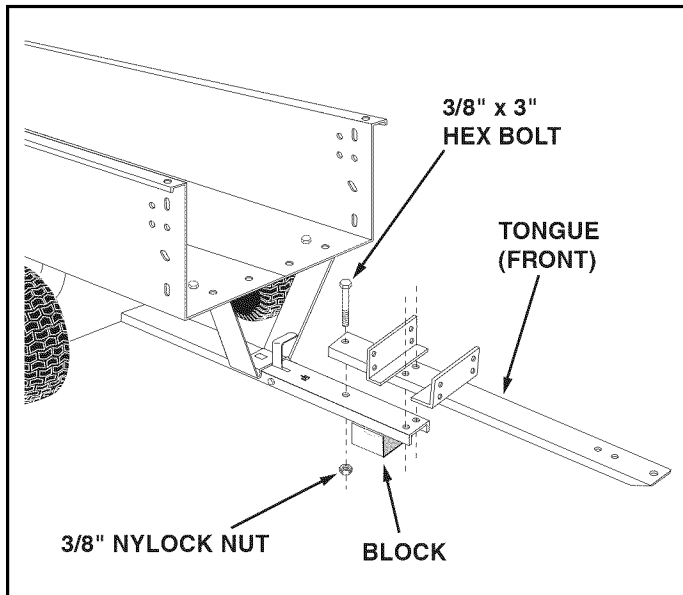

FIGURE 8

- Assemble the hitch bracket to the front tongue using two 3/8" x 1-1/4" hex bolts and 3/8" nylock nuts. **Tighten.** See figure 9.
- Secure the hitch pin to the hitch bracket and tongue with the hair cotter pin. See figure 9.

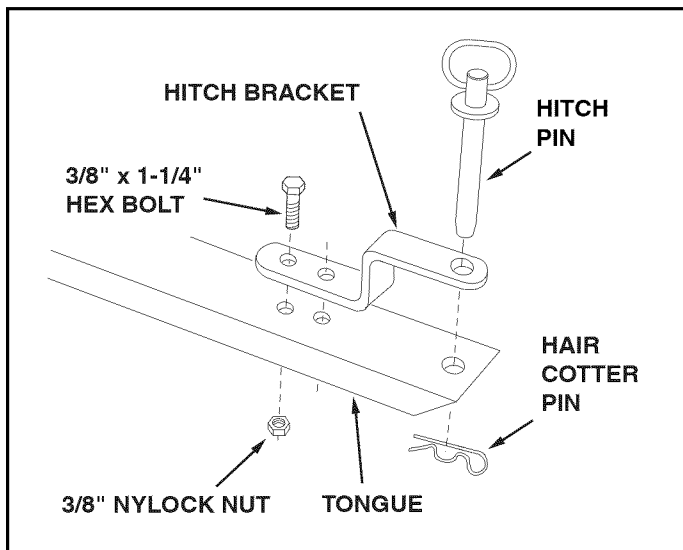

FIGURE 9

## ASSEMBLING VAC PARTS

- Release the latch lock lever and tilt the cart bed back. See figure 10.
- Assemble the front panel to the cart bed, sliding the bottom lip of the panel in between the cart bed and the latch stand bracket. Fasten the panel to the bottom and sides of the cart bed using six 1/4" x 5/8" hex bolts and 1/4" nylock nuts. **Tighten.** See figure 10.
- **Tighten** the two bolts that you assembled to the latch stand bracket in figure 5.

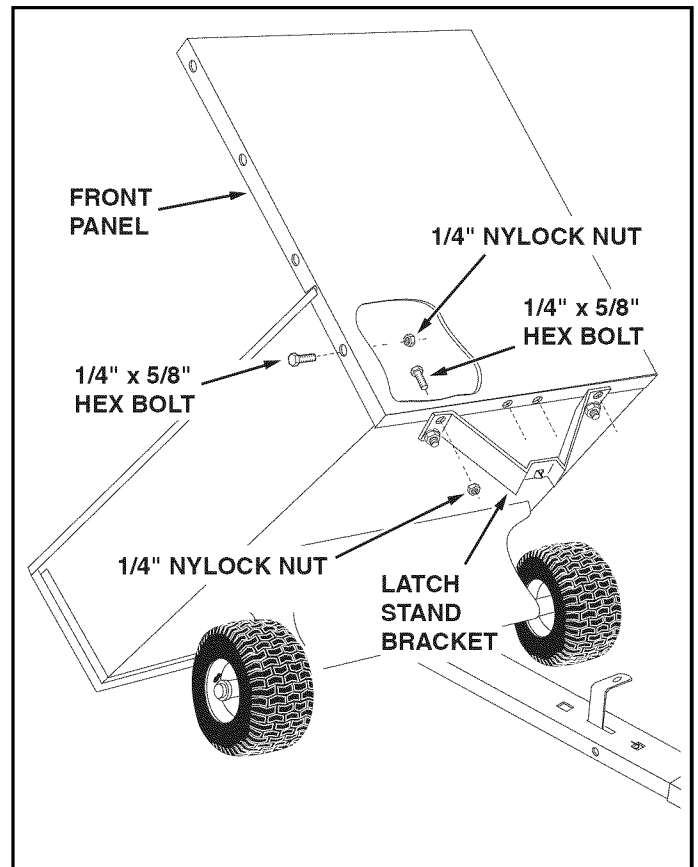

FIGURE 10

- Place a side panel on top of the cart bed flange, inside the lip of the front panel. Fasten the side panel to the front panel using three 1/4" x 5/8" hex bolts and 1/4" nylock nuts. Fasten the side panel to the cart bed flange using two 1/4" x 5/8" hex bolts, 1/4" flat washers and 1/4" nylock nuts. **Tighten**. See figure 11. Repeat on other side.

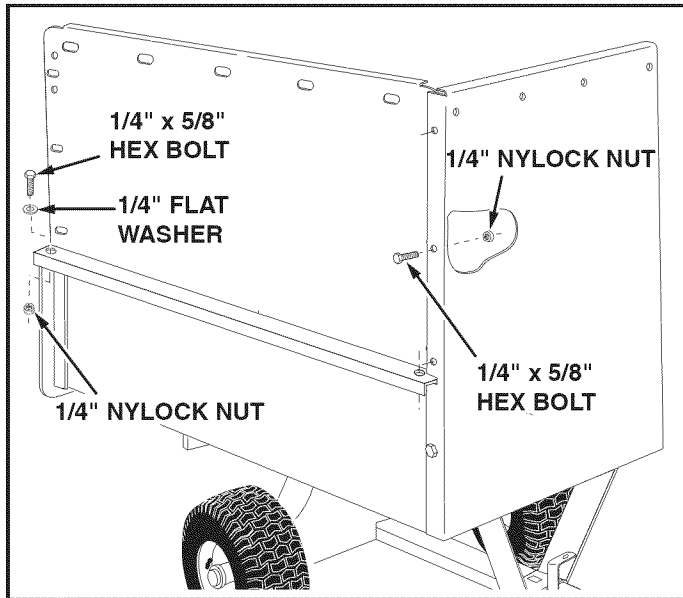

FIGURE 11

- Screw a 1/4" nylock nut onto a 1/4" x 1" hex bolt until it is about 1/4" from the bolt head. Insert the bolt into the hole shown in the side of the cart in figure 12. Fasten the bolt to the cart using a 1/4" nylock nut. **Tighten** so that the nut is one or two threads past the end of the bolt. Repeat on the other side.
- Assemble the cross brace to the top rear holes in the side panels using four 1/4" x 5/8" hex bolts and 1/4" nylock nuts. See figure 12.

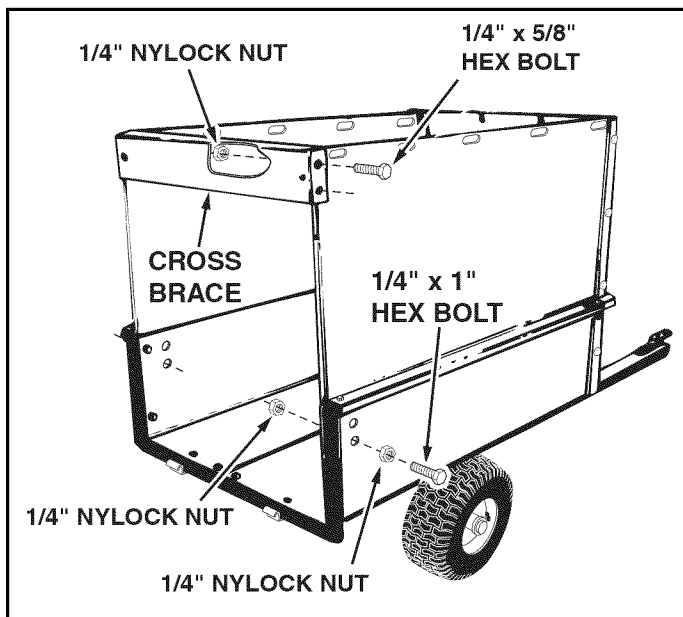

FIGURE 12

- Assemble a door latch at each end of the cross brace using a 5/16" x 3/4" hex bolt, a nylon washer and a 5/16" nylock nut. Place the nylon washer between the door latch and cross brace. **Tighten** so that latch is snug but will still rotate. See figure 13.

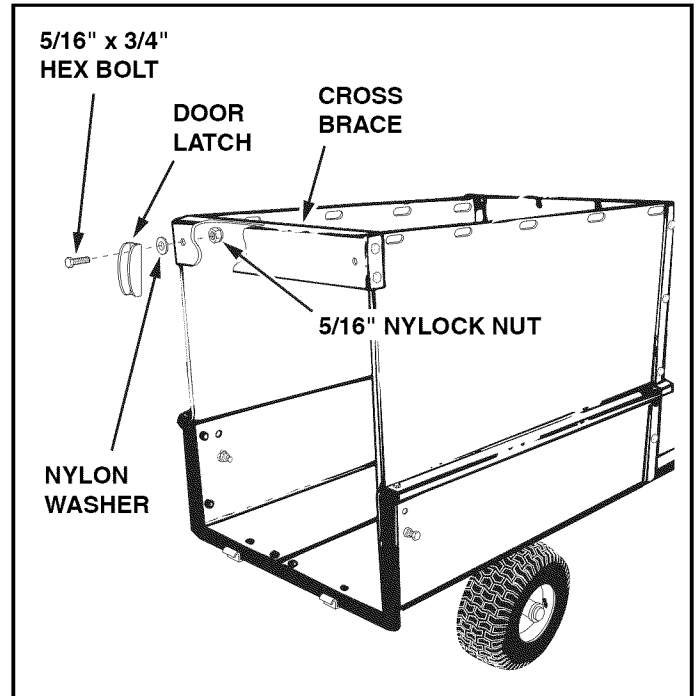

FIGURE 13

- Install the poly hard top using fourteen 1/4" x 3/4" hex bolts and 1/4" flat washers on the outside and fourteen 1/4" flat washers and 1/4" nylock nuts on the inside. **Tighten**. See figure 14.

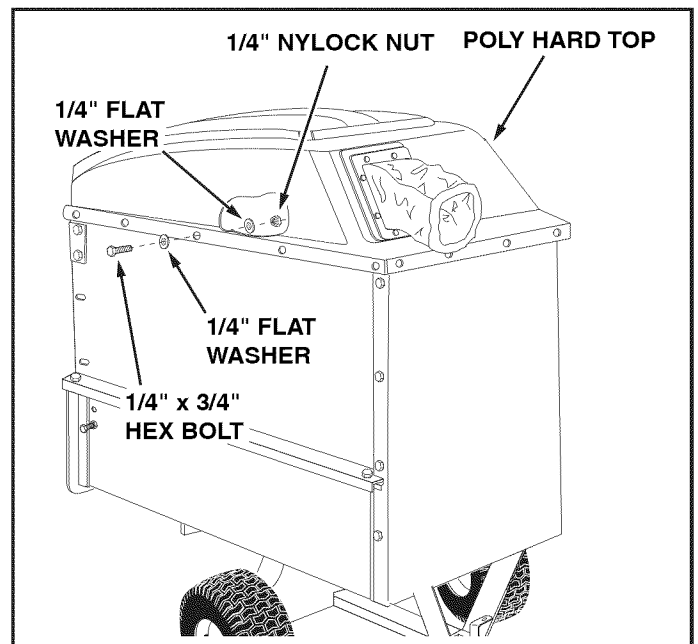

FIGURE 14

- Assemble a short tarp strap to rear door using one 1/4" x 1-1/4" hex bolt, two 1/4" flat washers and one 1/4" nylock nut. Assemble an "S" hook through loose end of strap. See figure 15. Repeat on other side of door.
- Assemble door to rear of cart by resting bottom of door on door supports and pushing top of door in against cross brace. Secure top of door using door latches on each side. See figure 15.
- Hook both the tarp straps onto the 1/4" x 1" hex bolts in the sides of the cart. See figure 15.

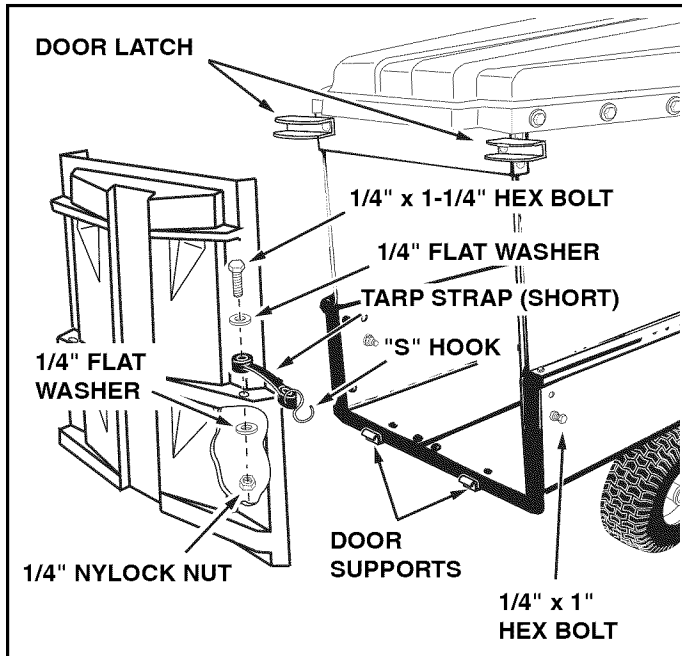

FIGURE 15

- Attach the engine/impeller housing assembly to the upper holes in the angles welded to the tongue. Use four 5/16" x 3/4" hex bolts and 5/16" nylock nuts. **Tighten.** See figure 16.

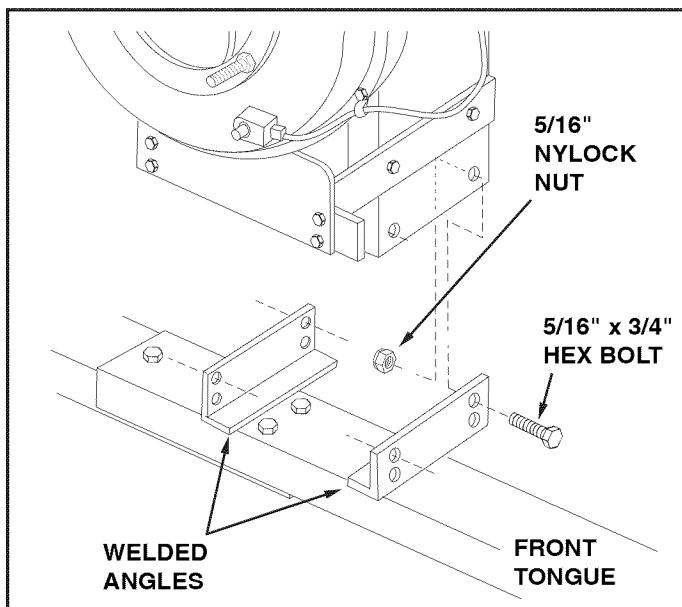

FIGURE 16

- Assemble the elbow to the impeller housing using four 5/16" x 3/4" thread forming hex bolts and four nylon washers. Push while turning to help start the bolts into the un-threaded holes. **Tighten.** See figure 17.
- To center the elbow with the opening in the hard top:
  - a. Push the vinyl boot back inside the opening.
  - b. Loosen by approximately 1/4 turn each, the four bolts that you assembled in figure 17.
  - c. Push against the elbow to center it with the sides of the opening.
  - d. **Retighten** the four bolts that you loosened.
- Pull the vinyl boot onto the end of the elbow.

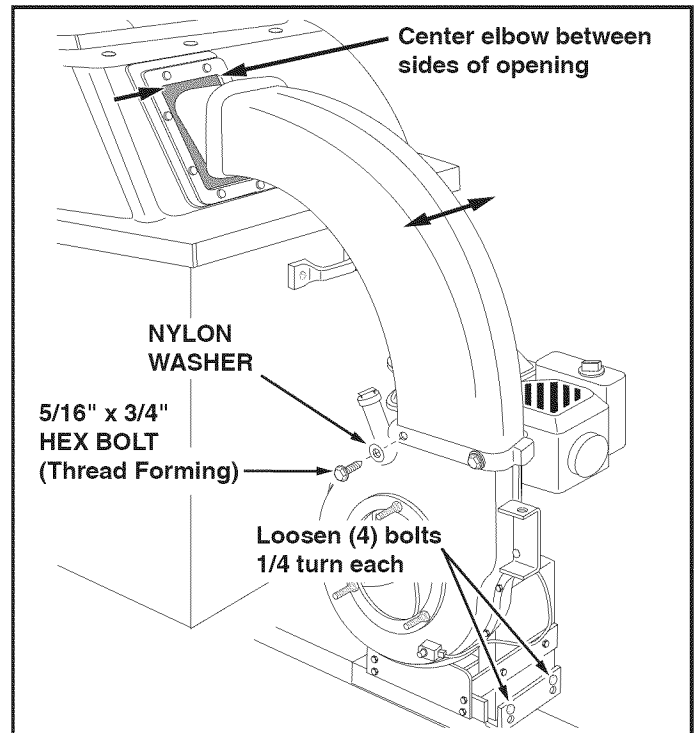

FIGURE 17

- Assemble the hose adapter (nozzle) to the front of the impeller housing and secure with the three knobs. Make sure that the switch actuator bracket contacts the switch on the housing. See figure 18.

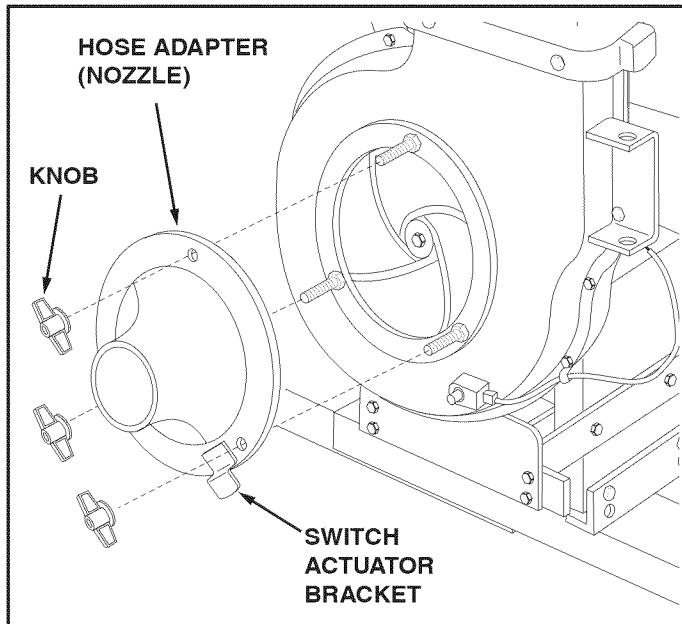

FIGURE 18

- Place a hose clamp onto one end of hose. Push hose onto hose adapter (nozzle). Tighten hose clamp onto hose and hose adapter. **Do not** collapse hose adapter when tightening clamp. See figure 19
- Place the hose hanger rod into the hose hanger bracket on the impeller housing assembly. See figure 19.
- Loop the 25" tarp strap under the hose. Hook to the hose hanger rod. See figure 19.

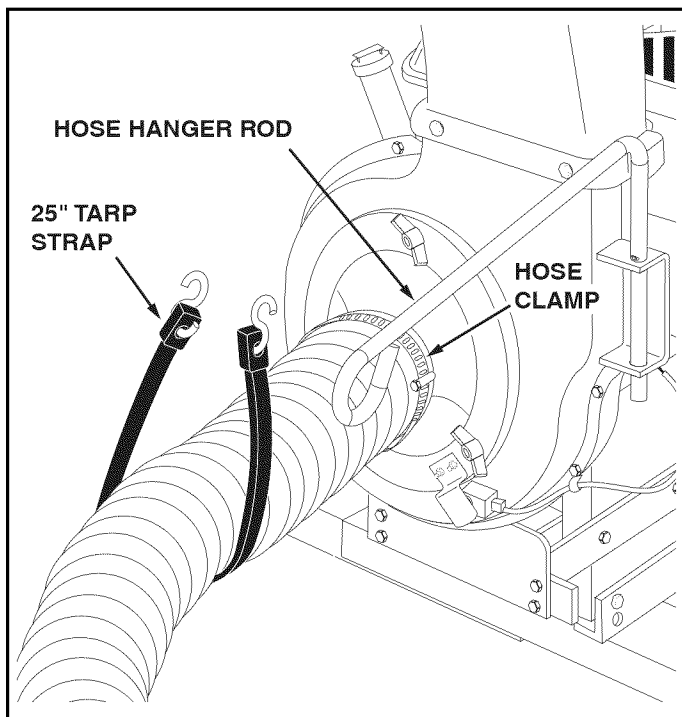

FIGURE 19

**HINT:** Tip the cart bed back for easier access in the next paragraph.

- Attach the chipper chute assembly to the weld bolts on the back side of the impeller housing using three 5/16" flat washers and 5/16" Nylock nuts. **Tighten.** See figure 20.
- Insert the tamper plug into the end of the chipper chute assembly.

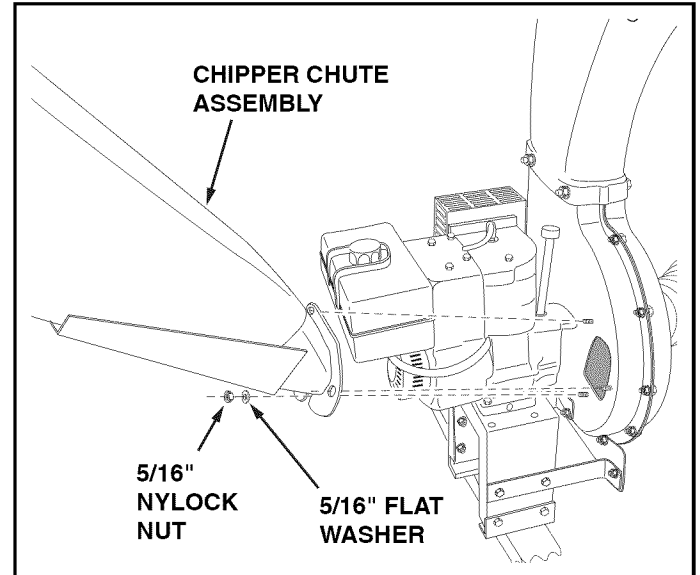

FIGURE 20

- Assemble the hitch plate to the tractor hitch if:
  - Your tractor has a square (straight) hitch frame, to help prevent binding.
  - Your tractor has a lightweight hitch frame that needs reinforcing for towing the Chip-N-Vac. Use a 1/2" x 1-1/4" hex bolt, a 7/16" flat washer and a 1/2" nylock nut. See figure 21.

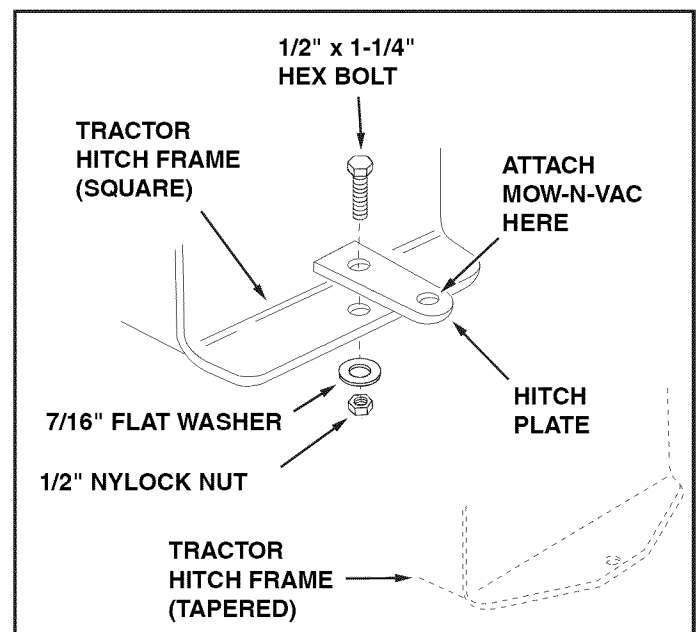

FIGURE 21



**BEFORE PROCEEDING**, look in the fold-out sheets included with this manual to find templates for Sears mower decks. If written instructions are printed on the template, follow those instructions instead of the instructions in this manual.

## ASSEMBLING THE DECK ADAPTER (#62468) TO THE MOWER DECK

**NOTE:** Not all of the parts in the deck adapter hardware package will be needed for your particular fit up.

### Contents of Hardware Pack for Deck Adapter:

REF.	PART NO.	QTY.	DESCRIPTION
A	43840	2	Hex Bolt, 5/16" x 1-1/4"
B	43661	4	Hex Bolt, 1/4" x 1"
C	43080	2	Carriage Bolt, 5/16" x 3/4"
D	47810	3	Nylock Nut, 5/16"
E	47189	5	Nylock Nut, 1/4"
F	43088	9	Flat Steel Washer, 1/4" Std.
G	43081	12	Flat Washer, 5/16" Std.
H	1543-69	5	Nylon Washer
I	23825	1	Mounting Strap
J	23826	1	Angle Bracket
K	23827	1	Mounting Bracket

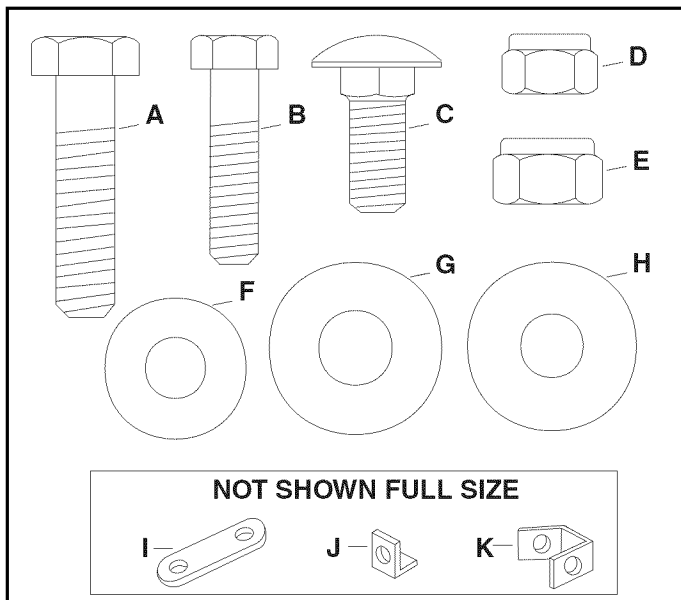

FIGURE 22- FULL SIZE

- Remove the mower discharge deflector from your mower deck. Save the deflector and hardware for remounting deflector.



**CAUTION:** Mower deflector must be replaced when Chip-N-Vac deck adapter is removed. Do Not operate mower unless adapter or deflector is in place and properly mounted.

- Identify your mower deck (see fold outs) and cut out the correct discharge opening template for your mower deck size. If there is no template for your deck size you can make your own template by marking around a piece of cardboard held against the edge of the discharge opening.
- Tape the template to the face of the adapter, locating template approximately 1/2" from front and 1/4" down from top of adapter. Keep as close to top as possible. See figure 23. Mark outline of template on face of adapter using white crayon, nail or scribe. Drill a starting hole inside the outline, then use a saber saw or key hole saw to cut out the opening. See figure 23.

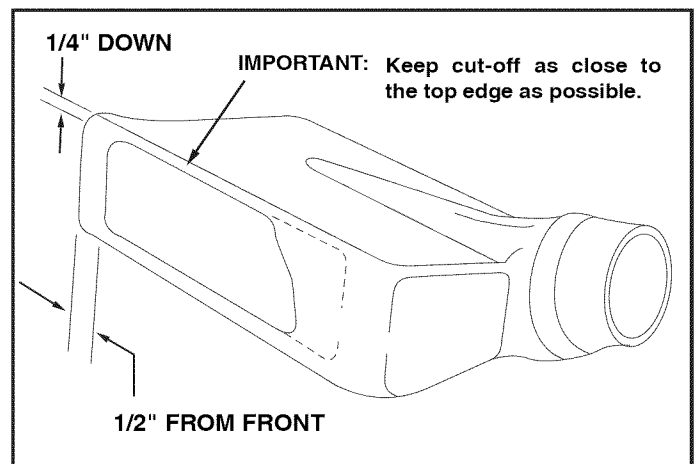

FIGURE 23

- Position the adapter over the deck opening, and check for fit of cutout as shown in figure 24. Trim cutout, if necessary, to allow tilting of adapter, keeping the fit as close as possible for best vacuum suction.

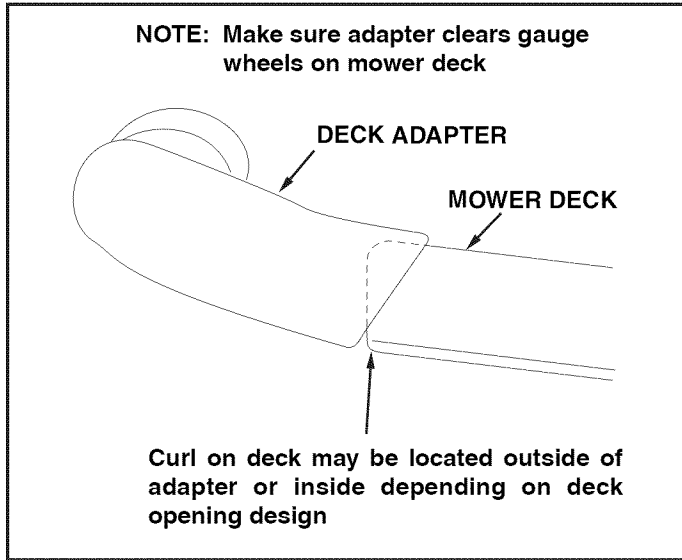

FIGURE 24

- Holding the adapter bracket and the deck adapter together, position the deck adapter on the mower deck. Keeping the edge of deck adapter as close as possible to the offset in the adapter bracket, see if the slot in the adapter bracket can be aligned with one or two of the deflector holes in your mower deck's discharge opening. If the bracket can not be located correctly using existing holes, it will be necessary to drill one or two 5/16" diameter holes in the deck. See figure 25.

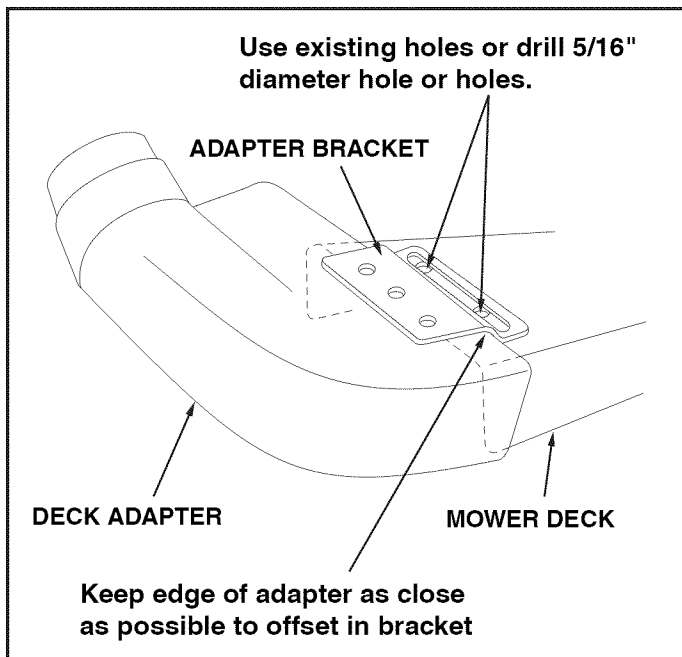

FIGURE 25

- Assemble the adapter bracket to the deck using two 5/16" x 1-1/4" hex bolts, 5/16" flat washers and 5/16" nylock nuts. See figure 26.

**NOTE:** It may be necessary to use extra 5/16" flat washers to shim under the bracket next to the deck surface. Ten extra washers have been furnished as shims. See figure 26.

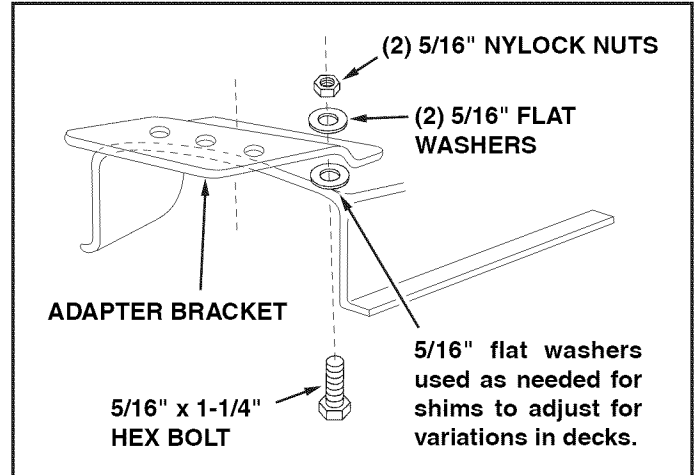

FIGURE 26

- With deck adapter positioned correctly over the discharge opening, use the adapter bracket as a template and drill three 9/32" diameter holes in the top of the deck adapter. See figure 27.
- Bolt deck adapter to bracket using three 1/4" x 1" bolts, nylon washers, 1/4" flat washers and 1/4" lock nuts. Nylon washers should be against the inside of the deck adapter. See figure 27.

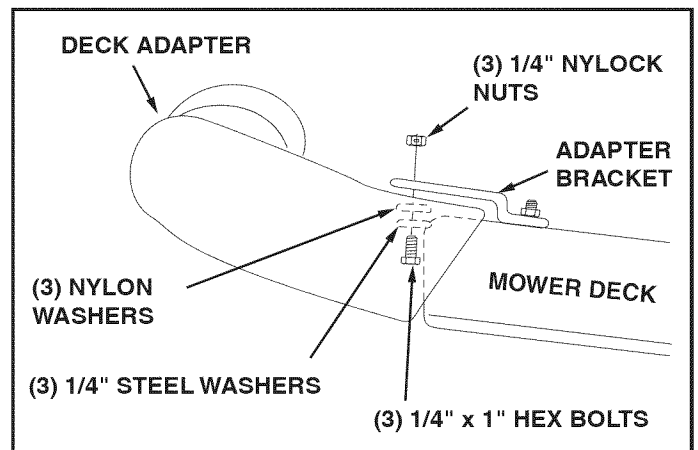

FIGURE 27

- Assemble end of hose and a hose clamp over the round opening of deck adapter and tighten clamp. **GO DIRECTLY TO THE OPERATION INSTRUCTIONS ON PAGE 16.**

# OPERATION

## BEFORE STARTING

- Your Chip-N-Vac engine is shipped without oil or gasoline. Service the Chip-N-Vac engine with oil and gas as instructed in the separate engine manual.
- Inspect the Chip-N-Vac to make sure all covers (rear door, vinyl boot, elbow, hose adapter, hose and deck adapter) are properly attached.
- Check tires for proper inflation (12 - 14 lbs).



**WARNING:** Never fill fuel tank indoors, or with the engine running, or while the engine is hot. Do not smoke while filling tank.

## HOW TO STOP YOUR CHIP-N-VAC

- To stop engine, move the throttle control lever to the OFF position.
- Disconnect spark plug wire from plug to prevent accidental starting while equipment is unattended or is being worked on.



**CAUTION:** The muffler and adjacent areas are **hot!**

## HOW TO START YOUR CHIP-N-VAC



**WARNING:** Never start or run the engine without all covers being properly attached to the blower housing and cart.

- Check oil and gas in Chip-N-Vac engine.
- Attach spark plug wire to spark plug.
- Move choke lever on engine to CHOKE position. (A warm engine may not require choking.)
- Move throttle control lever on engine to FAST position.
- Grasp starter handle and pull rope out slowly until engine reaches start of compression cycle (rope will pull slightly harder at this point). Let the rope rewind slowly.
- Pull rope with a rapid, continuous, full arm stroke. Keep a firm grip on starter handle. Let rope rewind slowly. Do not let starter handle snap back against starter.
- Repeat instructions in two preceding paragraphs until engine fires. When engine starts, move choke control gradually to RUN position.

## HOW TO USE YOUR CHIP-N-VAC



**CAUTION:** Vehicle braking and stability may be affected with the addition of an accessory or an attachment. Be aware of changing conditions on slopes.

- Inspect the Chip-N-Vac to make sure all covers (rear door, vinyl boot, elbow, chipper chute with tamper plug, hose adapter (nozzle), hose and deck adapter) are properly attached.
- Check tires for proper inflation (12 - 14 lbs).
- Check oil and gas in Chip-N-Vac engine.
- Begin operation at low speed, adjusting forward speed to match grass height and/or moisture condition to prevent clogging.
- Do not attempt to vacuum up any material other than vegetation found in a normal yard, such as light branches, leaves, twigs, etc.



**WARNING:** Should your Chip-N-Vac become clogged, shut off tractor and Chip-N-Vac engines. Before attempting to unclog, remove wire from spark plug to prevent accidental starting.

- To empty cart, shut off tractor engine and set brake.
- Shut off Chip-N-Vac engine.
- Remove rear door from cart.
- Release the latch holding cart down to the tongue by pulling up on the latch lever. See figure 28.
- Using a rake or suitable tool, pull the grass clippings and/or leaves out of cart.



**CAUTION:** To avoid possible injury, be sure that no one is near the cart before releasing the latch.

- After cart is emptied, secure cart to tongue with latch and reattach the rear door and the vinyl boot.

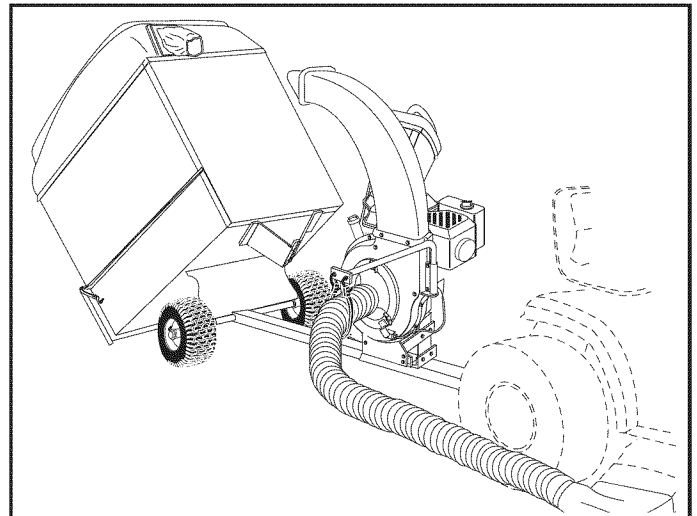

FIGURE 28



## USING THE CHIPPER CHUTE

- Material such as stalks or heavy branches up to 3" in diameter may be fed into the chipper chute as shown in figure 29.
- Be sure to wear eye protection and gloves when feeding material into the chipper chute.
- Use the tamper plug, not your hands, to force material down through the chipper chute.
- For best performance, it is important to keep the chipper blades sharp. If the composition of the material being discharged changes (becomes stringy, etc.) or if the rate of discharge slows down considerably, it is likely that the chipper blades are dull and need to be sharpened or replaced. Refer to the Service and Adjustments section, on page 29.



**WARNING:** Do not attempt to feed any material larger than 3" in diameter into the chipper chute. Personal injury or damage to the machine could result.



**DANGER:** Keep hands out of chipper chute. Rotating blades in impeller housing can cause serious injury. Use the tamper plug to help push material down into the chute.

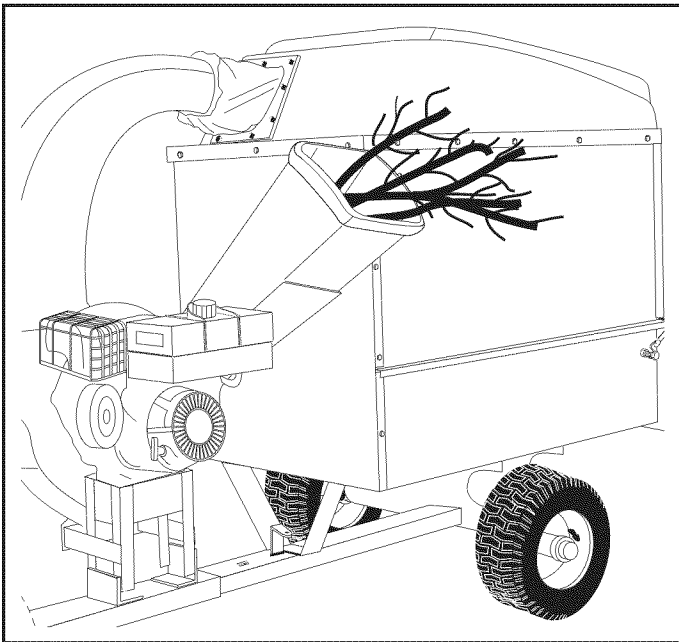

FIGURE 29

# MAINTENANCE

## CUSTOMER RESPONSIBILITIES

- Read and follow the maintenance schedule and the maintenance procedures listed in this section.

MAINTENANCE SCHEDULE Fill in dates as you complete regular service.	Service Dates											
	Before each use	After each use	Every season	Before storage								
Check for loose fasteners	X											
Check soft vinyl boot	X											
Check tire pressure	X											
Check engine oil level	X											
Lubricate			X									
Clean		X		X								
Maintain engine per instructions below and in engine manual.												

## BEFORE EACH USE

### CHECK FOR LOOSE FASTENERS

- Make a thorough visual check of the Chip-N- Vac for any bolts and nuts which may have loosened. Retighten any loose bolts and nuts.

### CHECK VINYL BOOT

- Check the soft vinyl boot (on front of hard top) for wear. Replace if worn or damaged.

### CHECK TIRE PRESSURE

- Check tire pressure regularly. Recommended tire pressure is 12-14 Lbs.

### CHECK ENGINE OIL LEVEL

- Check oil level before each use. Maintain engine oil as instructed in the separate engine manual.

## LUBRICATION

- At the beginning of each season, lubricate the latch, latch pivot bolt, and the axle where the hitch tongue pivots, with a light machine oil.
- At least once a season, grease or oil the wheel bearings. Use automotive wheel bearing type grease or 20 weight oil.



**WARNING:** Always stop engine and disconnect spark plug wire before cleaning, lubricating or before performing any repairs or maintenance.

## ENGINE MAINTENANCE

- Check **oil level** before each use. Maintain engine oil as instructed in the separate engine manual.
- Service **air cleaner** every 25 hours under normal conditions. Clean every few hours under extremely dusty conditions. Poor engine performance and flooding usually indicates that the air cleaner should be serviced. To service the air cleaner, refer to the separate engine manual.
- The **spark plug** should be cleaned and the gap reset once a season. Spark plug replacement is recommended at the start of each season. Check the engine manual for correct plug type and gap specifications.

## CLEANING

- Make sure the cart, the side and front panels and top are cleaned after each use. Grass clippings and leaves left in the cart will mildew and cause damage if not cleaned out.
- **Clean the engine** regularly with a cloth or brush. Keep the cooling fins on the engine housing clean to permit proper air circulation which is essential to engine performance and life. Be sure to remove all dirt and debris from muffler area.

## SERVICE AND ADJUSTMENTS

### SHARPENING OR REPLACING CHIPPER BLADES

- Disconnect the spark plug wire and move wire away from the spark plug.
- Remove the access plate by removing two hex lock nuts. See figure 30.
- Locate one of the chipper blades in the access plate opening by rotating the impeller assembly by hand. Remove the blade using a 3/16" allen wrench on the outside of the blade and a 1/2" wrench on the impeller assembly, inside the housing.
- Remove the other blade in the same manner.
- Replace or sharpen blades. If sharpening, make certain to remove an equal amount from each blade. Reassemble in reverse order.

**NOTE:** Make certain the blades are reassembled with the sharp edge facing upward, as viewed from the access plate opening.

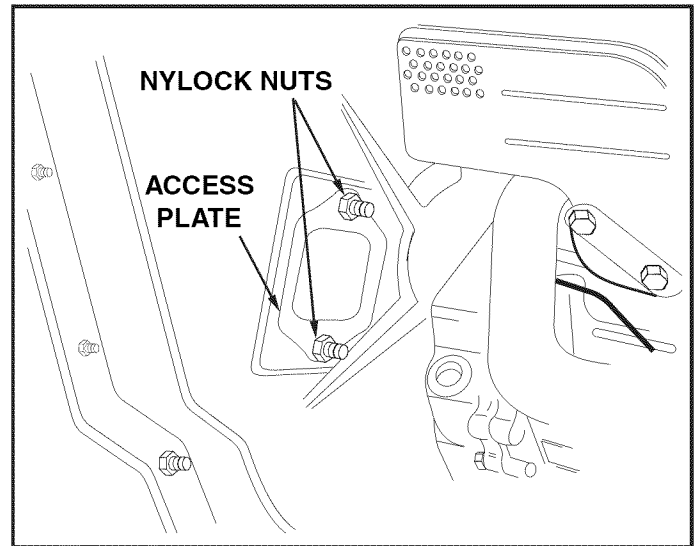

FIGURE 30

## STORAGE

- Clean the engine and the entire unit thoroughly.
- Refer to engine manual for correct engine storage instructions.
- If storing in an unventilated or metal storage shed, coat metal parts with light oil or silicone to prevent rust.
- Store unit in a clean, dry area.

## TROUBLESHOOTING

PROBLEM	POSSIBLE CAUSE(S)	CORRECTIVE ACTION
Engine fails to start	<ol style="list-style-type: none"> <li>1. Spark plug wire disconnected.</li> <li>2. Safety switch not contacted.</li> <li>3. Fuel tank empty, or stale fuel.</li> <li>4. Fuel shut-off valve closed (if so equipped).</li> <li>5. Faulty spark plug.</li> </ol>	<ol style="list-style-type: none"> <li>1. Connect wire to spark plug.</li> <li>2. Correctly install hose adapter nozzle.</li> <li>3. Fill tank with clean, fresh fuel.</li> <li>4. Open fuel shut-off valve.</li> <li>5. Clean, adjust gap or replace.</li> </ol>
Loss of power; operation erratic.	<ol style="list-style-type: none"> <li>1. Spark plug wire loose</li> <li>2. Unit running on CHOKE.</li> <li>3. Blocked fuel line or stale fuel.</li> <li>4. Water or dirt in fuel system.</li> <li>5. Carburetor out of adjustment.</li> <li>6. Dirty air cleaner.</li> </ol>	<ol style="list-style-type: none"> <li>1. Connect and tighten spark plug wire.</li> <li>2. Move choke lever to OFF position.</li> <li>3. Clean fuel line; fill tank with clean fresh gasoline.</li> <li>4. Disconnect fuel line at carburetor to drain fuel tank. Refill with fresh fuel.</li> <li>5. Adjust carburetor.*</li> <li>6. Service air cleaner.*</li> </ol>
Engine overheats	<ol style="list-style-type: none"> <li>1. Carburetor not adjusted properly.</li> <li>2. Engine oil level low.</li> </ol>	<ol style="list-style-type: none"> <li>1. Adjust carburetor.*</li> <li>2. Fill crankcase with proper oil.</li> </ol>
Too much vibration	Loose parts or damaged impeller.	Stop engine immediately and disconnect spark plug wire. Tighten all bolts and nuts. Make all necessary repairs. If vibration continues, have unit serviced by an authorized service dealer.
Unit does not discharge	<ol style="list-style-type: none"> <li>1. Discharge chute (elbow) clogged.</li> <li>2. Foreign object lodged in impeller.</li> <li>3. Chip-N-Vac cart is full.</li> </ol>	<ol style="list-style-type: none"> <li>1. Stop engine immediately and disconnect spark plug wire. Clean inside of housing and discharge chute (elbow).</li> <li>2. Stop engine immediately and disconnect spark plug wire. Remove lodged object.</li> <li>3. Empty cart.</li> </ol>
Rate of discharge when chipping slows considerably, or composition of discharged material changes.	Chipper blades dull.	Sharpen or replace chipper blades.

\*Refer to the engine manual packed with your unit.

NOTE: For repairs beyond the minor adjustments listed above, please contact your nearest authorized service dealer.

## NOTES

## NOTES

# PARTS

## REPAIR PARTS FOR MODEL 486.25013 CHIP-N-VAC IMPELLER HOUSING ASSEMBLY

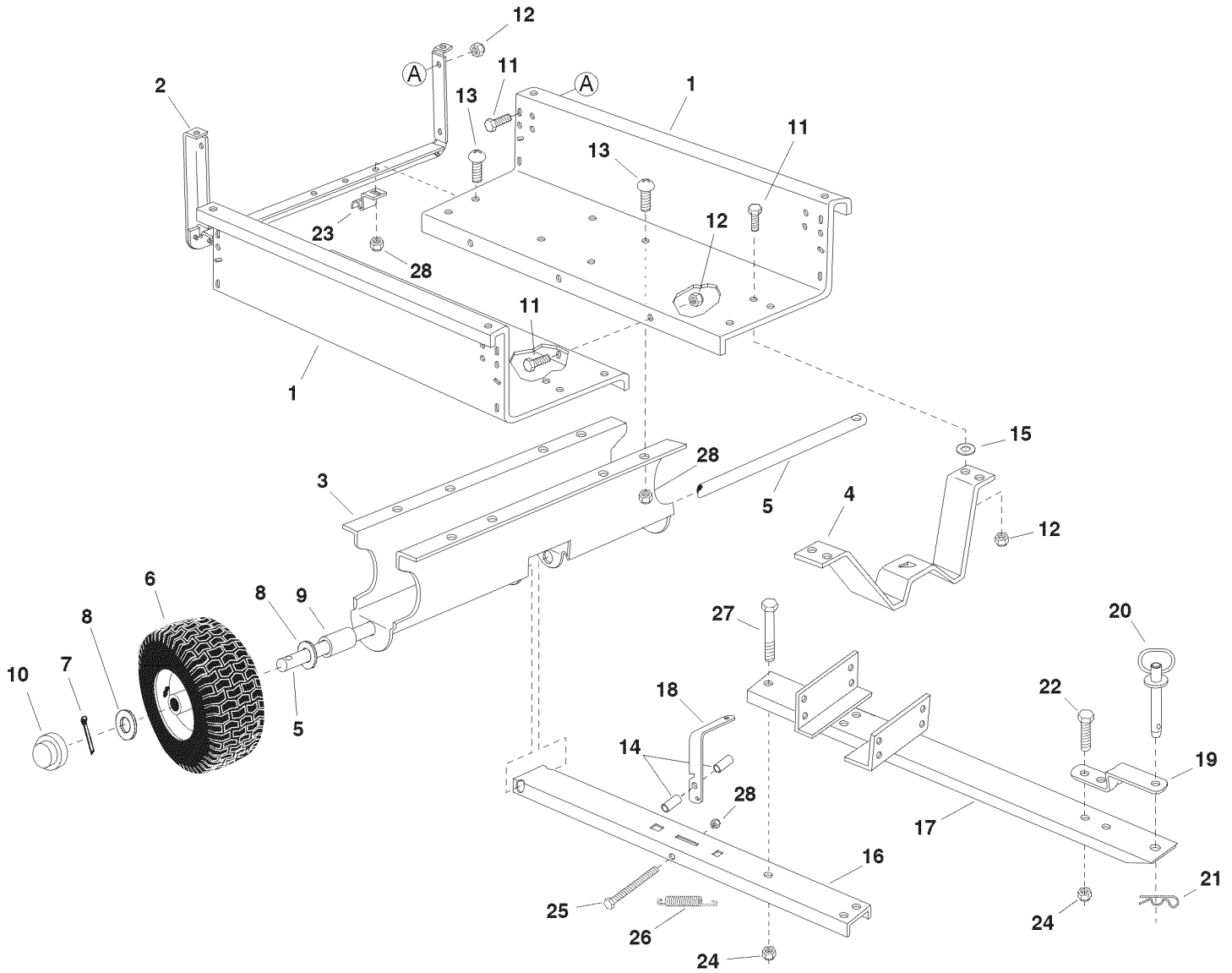

REF.	PART NO.	QTY.	DESCRIPTION	REF.	PART NO.	QTY.	DESCRIPTION
1	23985	2	Cart Body	15	43088	2	Washer, Flat 1/4"
2	62458	1	Tailgate Reinforcement Bracket	16	63917	1	Tongue Weldment Ass'y. (Rear)
3	23507	1	Wheel Support	17	63155	1	Tongue Weldment Ass'y. (Front)
4	24497	1	Latch Stand Bracket	18	24614	1	Latch Lock Lever
5	24897	1	Axle, Wheel 1" Dia.	19	23475	1	Hitch Bracket
6	42159	2	Wheel w/Tire, 15 x 6.00	20	43884	1	Hitch Pin
7	43093	2	Cotter Pin, 1/8" Dia. x 1-1/2"	21	43343	1	Pin, Hair Cotter 1/8"
8	43601	4	Washer, Flat 1"	22	43087	2	Hex Bolt, 3/8-16 x 1-1/4"
9	44678	2	Spacer Tube, 1-1/4" x 2" Lg.	23	23838	2	Door Support
10	43014	2	Hub Cap	24	HA21362	5	Nylock Nut, 3/8-16
11	43866	9	Hex Bolt, 1/4-20 x 5/8"	25	47407	1	Hex Bolt, 5/16-18 x 3-3/4"
12	47189	9	Nylock Nut, 1/4-20	26	47408	1	Spring, Extension
13	43814	12	Truss Hd. Bolt, 5/16-18 x 3/4"	27	43574	3	Hex Bolt, 3/8-16 x 3"
14	41076	2	Spacer	28	47810	13	Nylock Nut, 5/16-18

# REPAIR PARTS FOR MODEL 486.25013 CHIP-N-VAC IMPELLER HOUSING ASSEMBLY

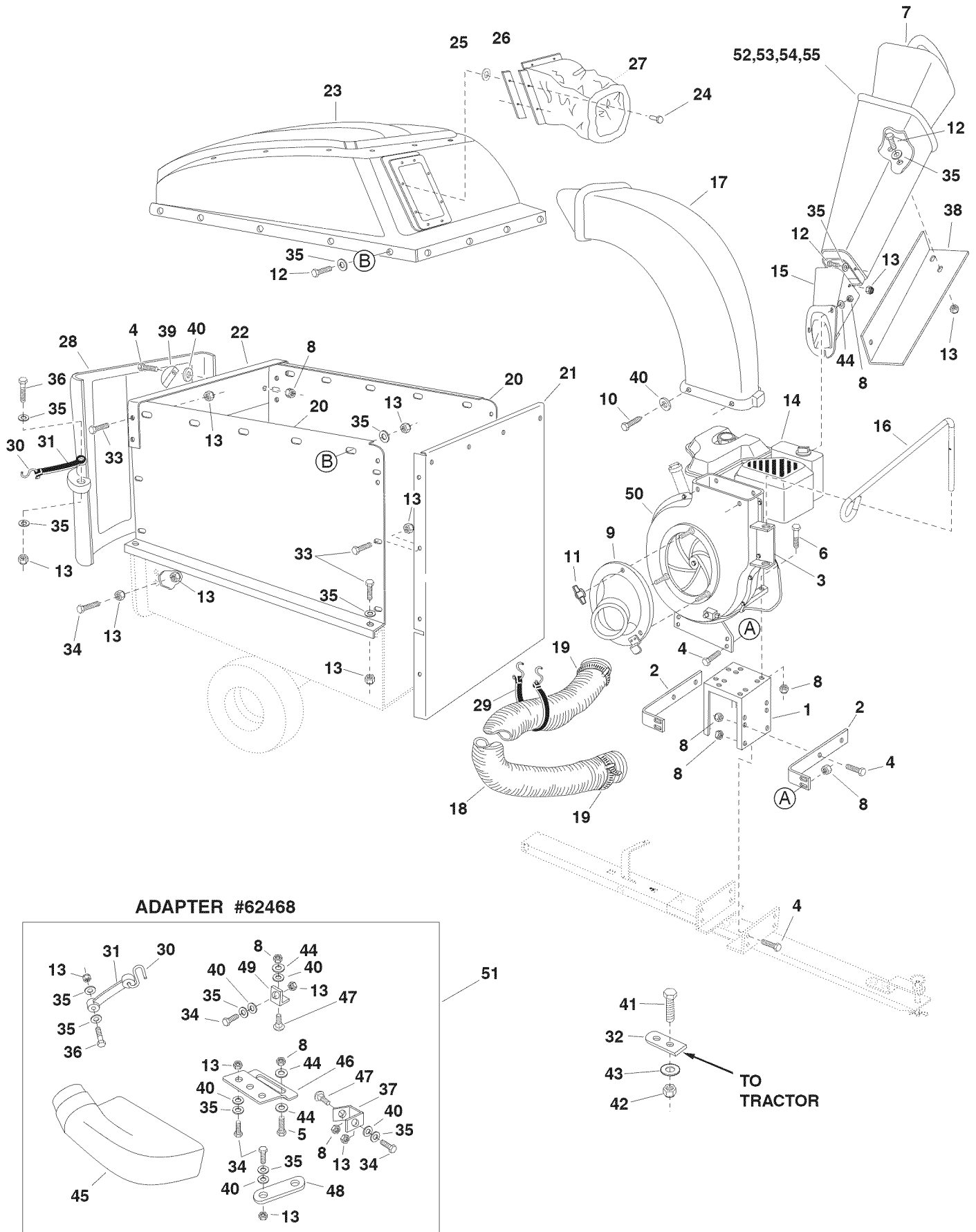





**REPAIR PARTS FOR MODEL 486.25013 CHIP-N-VAC  
IMPELLER HOUSING ASSEMBLY**

REF.	PART NO.	QTY.	DESCRIPTION	REF.	PART NO.	QTY.	DESCRIPTION
1	24080	1	Engine Base	30	44849	4	"S" Hook, #32
2	24078	2	Brace, Housing	31	44850	4	Strap, Tarp (Less Hooks)
3	24958	1	Hose Hanger Bracket	32	23540	1	Hitch Plate
4	43182	14	Bolt, Hex 5/16-18 x 3/4"	33	43866	20	Bolt, Hex 1/4-20 x 5/8"
5	43840	2	Bolt, Hex 5/16-18 x 1-1/4"	34	43661	6	Bolt, Hex 1/4-20 x 1"
6	43085	4	Bolt, Hex 5/16-18 x 1-1/2"	35	43088	47	Washer, 1/4" STD
7	731-1617	1	Tamper, Plug	36	1509-90	5	Bolt, Hex 1/4-20 x 1-1/4"
8	47810	24	Nut, Nylock 5/16-18	37	23827	1	Mounting Bracket
9	43791	1	Hose Adapter (Nozzle)	38	24098	1	Bracket, Chute Reinforcement
10	47630	4	Screw, Self Tap 5/16-18 x 3/4"	39	23789	2	Door Latch
11	712-0421	3	Knob (See Item #8, Page 24)	40	1543-69	9	Washer, Nylon 21/64"
12	43012	19	Bolt, Hex 1/4-20 x 3/4"	41	43351	1	Bolt, Hex 1/2-13 x 1-1/4"
13	47189	48	Nut, Nylock 1/4-20 Thd.	42	712-3083	1	Nut, Nylock 1/2-13
14	42462	1	Engine	43	43352	1	Washer, Flat 7/16"
15	681-0068	1	Chute Assembly	44	43081	15	Washer, 5/16" STD
16	49974	1	Hose Hanger Rod	45	43830	1	Adapter, Deck
17	46420	1	Elbow	46	23560	1	Bracket, Deck Adapter
18	41882	1	Hose (6" x 84")	47	43080	2	Bolt, Carr. 5/16" x 3/4"
19	43793	2	Hose Clamp 6"	48	23825	1	Mounting Strap
20	24678	2	Side Panel Cart Extension	49	23826	1	Angle Bracket
21	24679	1	Front Panel Cart Extension	50		1	Impeller Housing Assembly (See page 26)
22	23836	1	Cross Brace				
23	64244	1	Hard Top Assembly (Includes 24,25,26,27)	51	62468	1	Deck Adapter Kit (Includes parts in box on page 24)
24	43882	4	Rivet, 3/16"	52	63376	1	Chipper Chute Assembly (Upper)
25	43910	4	Washer, Flat 3/16"	53	735-0249	1	Flap, Chute (Included in item 52)
26	24798	4	Boot Mounting Strap	54	781-0633	1	Strap, Flap (Included in item 52)
27	48133	1	Vinyl Boot (Hardtop)	55	728-3001	3	Rivet, Pop 5/32"
28	44790	1	Poly Rear Door		42486	3	Owner's Manual
29	43790	1	Strap, Tarp 25"				

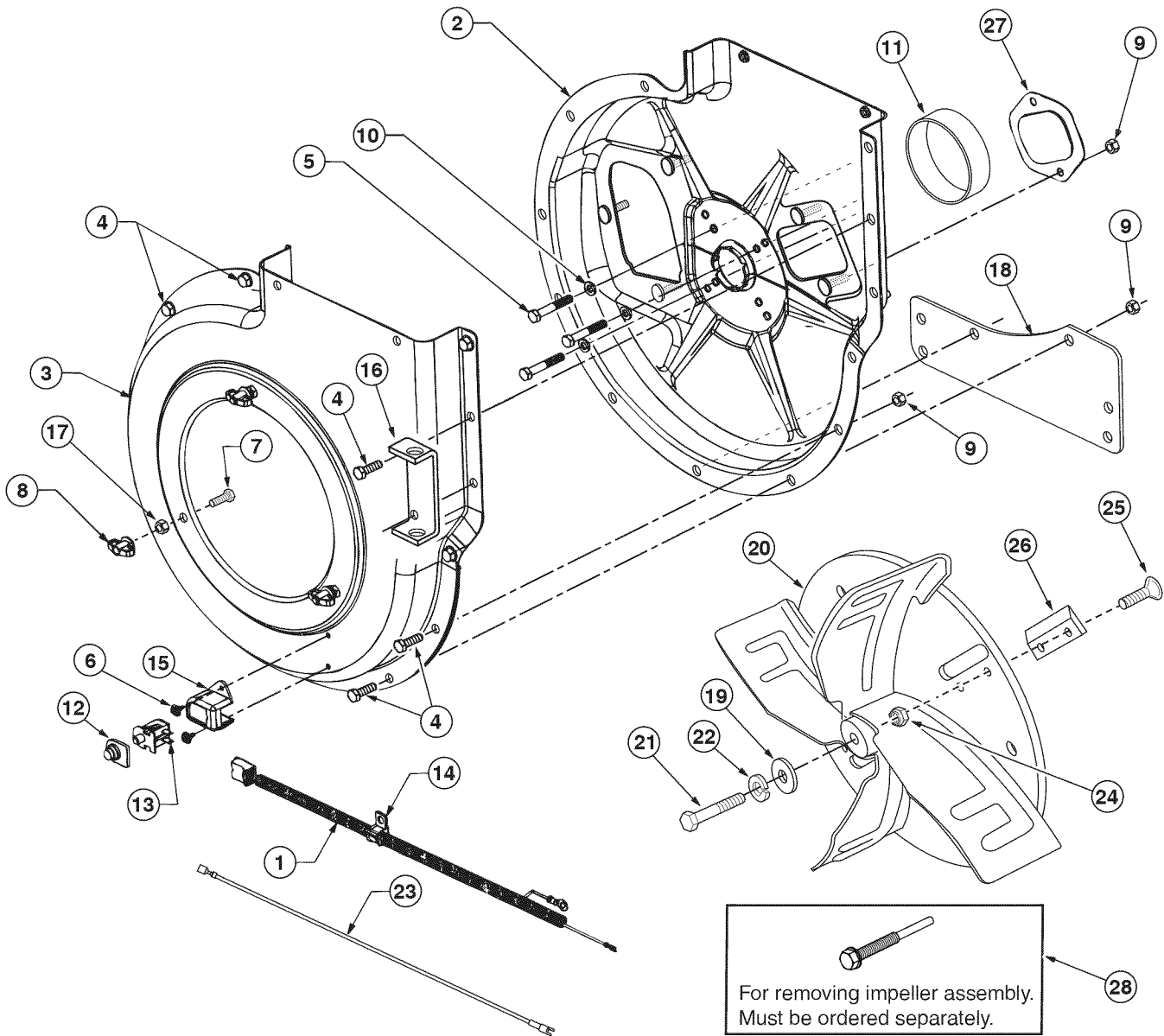
## REPAIR PARTS FOR MODEL 486.25013 CHIP-N-VAC IMPELLER HOUSING ASSEMBLY



  
 For removing impeller assembly.  
 Must be ordered separately.

REF.	PART NO.	QTY.	DESCRIPTION	REF.	PART NO.	QTY.	DESCRIPTION
1	629-0241A	1	Harness, Wire	15	731-1613	1	Cover, Switch
2	63993	1	Housing Ass'y. Inner	16	24958	1	Hose Hanger Bracket
3	24633	1	Housing Ass'y. Outer	17	46584	3	Hex Nut, Whizlock 5/16-18 Thd.
4	43182	12	Bolt, Hex 5/16-18 x 3/4"	18	24606	1	Spacer, Housing
5	710-0772	4	Bolt, Hex 5/16-24 x 2"	19	736-0247	1	Flat Washer, 13/32" x 1-1/4"
6	710-1268	2	Screw, Self Tap #10-16 x 3/8"	20	66791	1	Impeller Assembly
7	43063	3	Bolt, Hex 5/16-18 x 1"	21	710-1273	1	Bolt, Hex 3/8-24 x 2-3/4"
8	712-0421	3	Knob	22	43003	1	Lockwasher, 3/8"
9	47810	14	Nut, Hex Nylock 5/16-18	23	629-0923	1	Harness Adapter
10	43086	4	Washer, Lock 5/16" Spring Type	24	44738	4	Nut, Hex Lock 5/16-24 "Unitork"
11	719-0330B	1	Adapter, Mounting	25	710-1054	4	Screw, Flat Hd. 5/16-24 x 1"
12	725-1700	1	Cover, Switch	26	742-0544	2	Blade, Chipper
13	725-3166	1	Snap Mount Switch	27	781-0627	1	Cover, Chipper
14	726-0272	1	Clamp	28	42294	1	Impeller Service Tool

# SUGGESTED GUIDE FOR SIGHTING SLOPES FOR SAFE OPERATION OF TRACTOR WITH ATTACHMENT

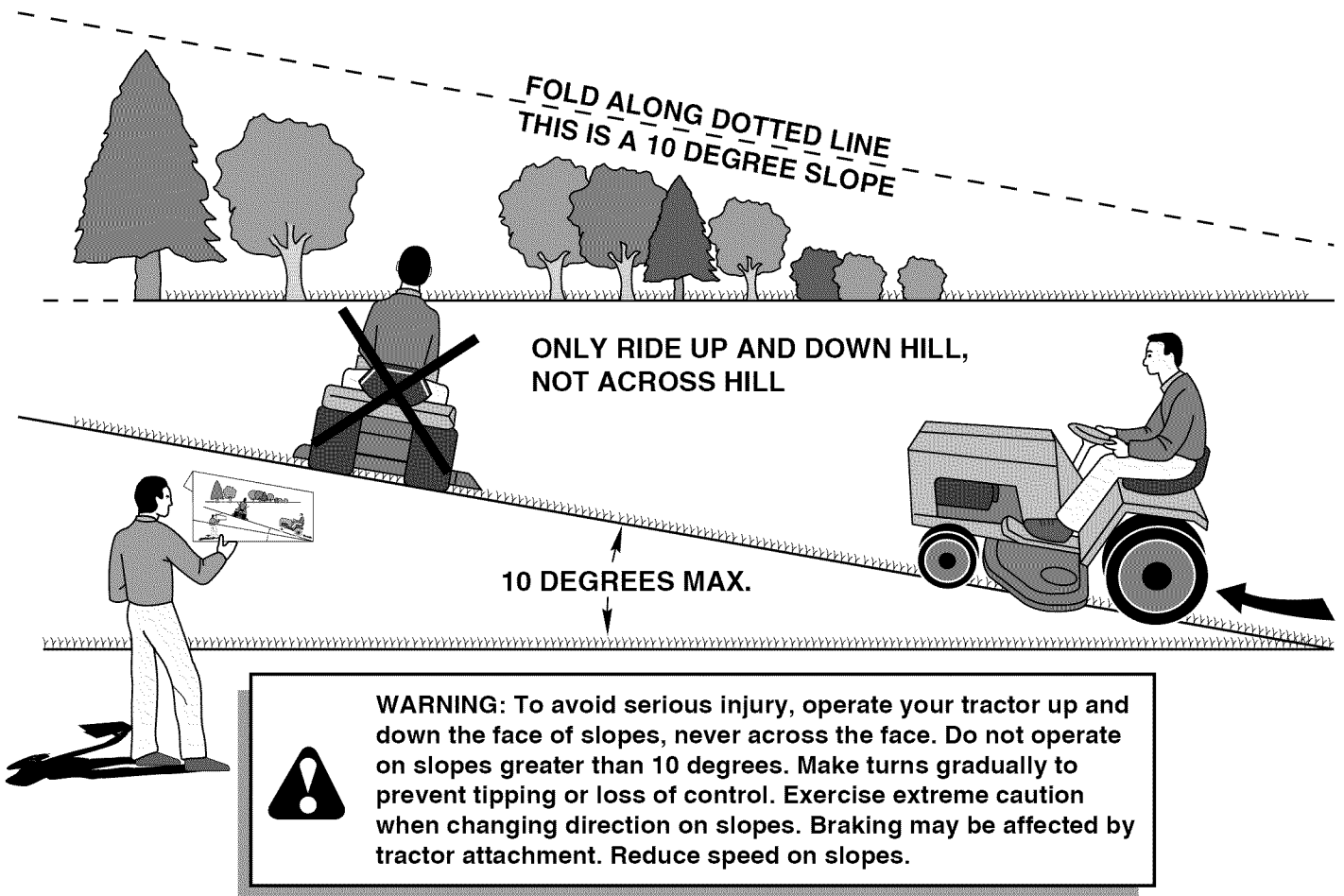

1. Fold this page along dotted line indicated above.
2. Hold page before you so that its left edge is vertically parallel to a tree trunk or other upright structure.
3. Sight across the fold in the direction of hill slope you want to measure.
4. Compare the angle of the fold with the slope of the hill.

**CRAFTSMAN®**

**Riding Equipment  
questions or problems?**

**Satisfaction with your purchase  
is our number one concern!**

**To troubleshoot problems,  
get answers to questions, order parts,  
or schedule repair service for your  
Riding Equipment, call the number below.**

**Para respuestas a preguntas o problemas,  
y ordenar piezas o pedir servicio para la  
reparación de su equipo, llame el número abajo.**

---

**1-800-659-5917**

**Craftsman Help Line**

---

**[www.craftsman.com](http://www.craftsman.com)**