

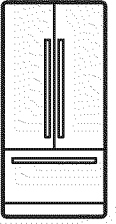

*Thinking of you*  
**Electrolux**



**EN** FREEZER / REFRIGERATOR  
**FR** RÉFRIGÉRATEUR / CONGÉLATEUR  
**ES** REFRIGERADOR CON CONGELADOR

**USE AND CARE GUIDE**  
**GUIDE D'UTILISATION ET D'ENTRETIEN**  
**GUIA DE USO Y CUIDADO**

## Please read and save this guide

Thank you for choosing Electrolux, our new premium brand in home appliances. This Use & Care Guide is part of our commitment to customer satisfaction and product quality throughout the service life of your new appliance.

## Keep a record for quick reference

Purchase date

Electrolux model number

Electrolux serial number



### NOTE

Registering your product with Electrolux enhances our ability to serve you. You can register online at [www.electroluxappliances.com](http://www.electroluxappliances.com) or by sending your Product Registration Card in the mail.

## Questions?

For toll-free telephone support in the U.S. and Canada:  
1-877-4ELECTROLUX (1-877-435-3287)

For online support and product information visit <http://www.electroluxappliances.com>

## Table of contents

<b>Finding Information</b> .....	2
<b>Safety</b> .....	3
<b>Feature Overview</b> .....	5
<b>Installation</b> .....	6
<b>Removing the Doors</b> .....	11
<b>Installing Door Handles</b> .....	13
<b>Connecting the Water Supply</b> .....	14
<b>Controls</b> .....	15
<b>Automatic Ice Maker</b> .....	17
<b>Storage Features</b> .....	18
<b>Storing Food and Saving Energy</b> .....	23
<b>Normal Operating Sounds &amp; Sights</b> .....	24
<b>Changing the Water and Air Filters</b> .....	25
<b>Care and Cleaning</b> .....	27
<b>Common Solutions for Concerns</b> .....	30
<b>Warranty</b> .....	34

## Installation Checklist

### Doors

- Handles are secure and tight
- Door seals completely to cabinet on all sides
- Freezer door is level across the top

### Leveling

- Refrigerator is level, side-to-side and tilted 1/4 inch (6 mm) front-to-back
- Toe grille is properly attached to refrigerator
- Cabinet is sitting solid on all corners

### Electrical Power

- House power turned on
- Refrigerator plugged in

### Ice Maker

- House water supply connected to refrigerator
- No water leaks present at all connections
- Ice maker is turned ON
- Ice operates correctly
- Front filter must be flush with filter housing (select models)

### Final Checks

- Shipping material removed
- Fresh food and freezer temperatures set

## Important safety instructions

### Safety Precautions

Do not attempt to install or operate your unit until you have read the safety precautions in this manual. Safety items throughout this manual are labeled with a Danger, Warning, or Caution based on the risk type.

### Definitions

 This is the safety alert symbol. It is used to alert you to potential personal injury hazards. Obey all safety messages that follow this symbol to avoid possible injury or death.

#### DANGER

DANGER indicates an imminently hazardous situation which, if not avoided, will result in death or serious injury.

#### WARNING

WARNING indicates a potentially hazardous situation which, if not avoided, could result in death or serious injury.

#### CAUTION

CAUTION indicates a potentially hazardous situation which, if not avoided, may result in minor or moderate injury.

#### IMPORTANT

Indicates installation, operation, or maintenance information which is important but not hazard-related.

### General Safety

#### WARNING

Please read all safety instructions before using your new refrigerator.

- Do not store or use gasoline or other flammable liquids near this or any other appliance. Read product labels for warnings regarding flammability and other hazards.
- Do not operate the refrigerator in the presence of explosive fumes.
- Avoid contact with any moving parts of the automatic ice maker.

- Remove all staples from the carton to avoid injury. Staples can also damage finishes if they come in contact with other appliances or furniture.

### Child Safety

Packing Materials:

- Packing cartons covered with rugs, bedspreads, plastic sheets, or stretch wrap may become airtight chambers and can quickly cause suffocation.
- Destroy or recycle the product's carton, plastic bags, and any other exterior wrapping material immediately after the refrigerator is unpacked. Children should never play with these items.

### Child Entrapment and Suffocation:

- These problems are not limited to the past. Whether junked, abandoned, or temporarily stored (even for a few hours), unattended refrigerators and freezers are dangerous. Please take the precautions listed below.

### Proper Disposal of Refrigerators/Freezers

We strongly encourage responsible appliance recycling/disposal methods. Check with your utility company or visit [www.energystar.gov/recycle](http://www.energystar.gov/recycle) for more information on recycling your old refrigerator.

Before you recycle or dispose of your old refrigerator/freezer:

- Remove the doors.
- Leave the shelves and baskets in place so children may not easily climb inside.
- Have refrigerant and compressor oil removed by a qualified service technician.

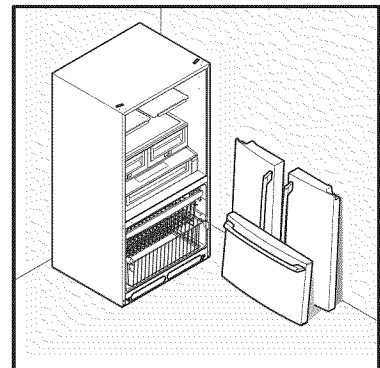

# 4 Safety

## Electrical information

### WARNING

You must follow these guidelines to ensure that your refrigerator's safety mechanisms are operating correctly.

- The refrigerator must be plugged into its own dedicated 115 Volt, 60 Hz, AC-only non-GFCI electric outlet. The power cord of the appliance is equipped with a three-prong grounding plug for your protection against electrical shock hazards. It must be plugged directly into a properly grounded three-prong receptacle. The receptacle must be installed in accordance with local codes and ordinances. Consult a qualified electrician. **Do not use an extension cord or adapter plug.**
- If the power cord is damaged, it should be replaced by the manufacturer, service technician, or a qualified person.
- Never unplug the refrigerator by pulling on the power cord. Always grip the plug firmly and pull straight out from the receptacle to prevent damaging the power cord.
- To avoid electrical shock, unplug the refrigerator before cleaning and before replacing a light bulb or LED light.
- Performance may be affected if the voltage varies by 10% or more. Operating the refrigerator with insufficient power can damage the compressor. Such damage is not covered under your warranty.
- Do not plug the unit into an outlet controlled by a wall switch or pull cord to prevent the refrigerator from being turned off accidentally.

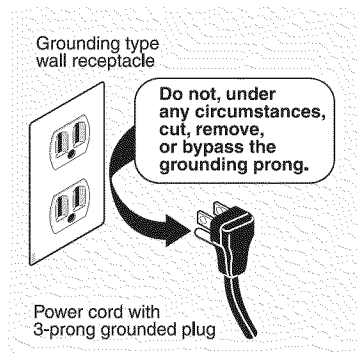

### IMPORTANT

To turn off power to your refrigerator, unplug the power cord from the wall outlet.

## Understanding features and terms

Your Electrolux refrigerator is designed for optimal convenience and storage flexibility. The illustration below is provided to assist you with familiarizing yourself with product features and terminology.



### NOTE

\*Features may vary according to model.  
Model is shown without freezer drawer cover.

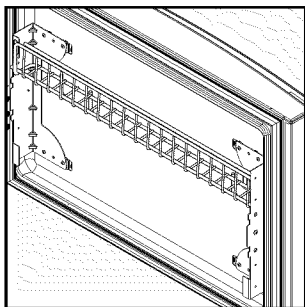
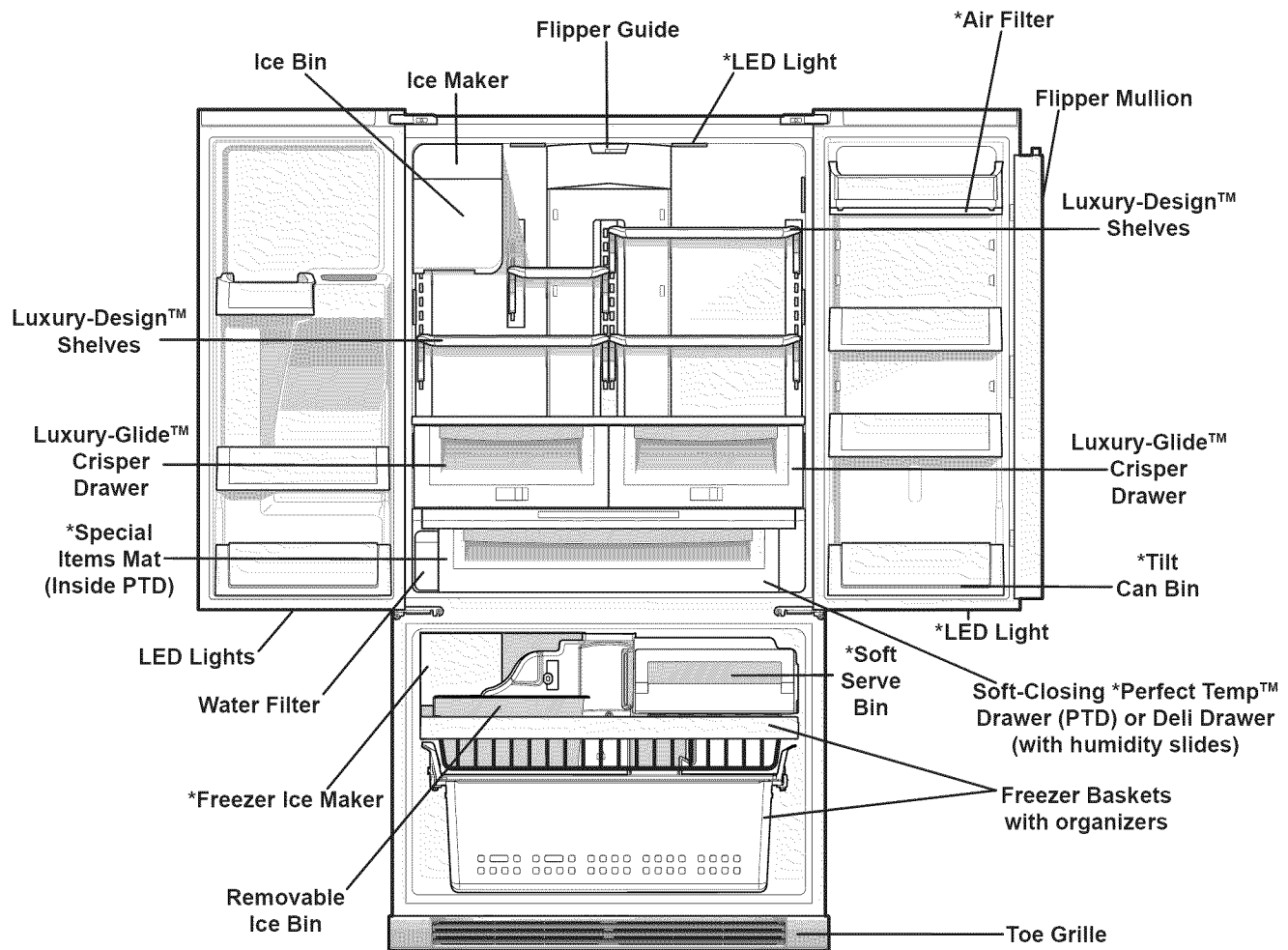

\*Wire Shelf (inside freezer drawer)



### IMPORTANT

Features not included with your refrigerator can be purchased at [www.electroluxappliances.com](http://www.electroluxappliances.com) or by calling 1-877-435-3287.

# 6 Installation

## Required Tools

You will need the following tools:

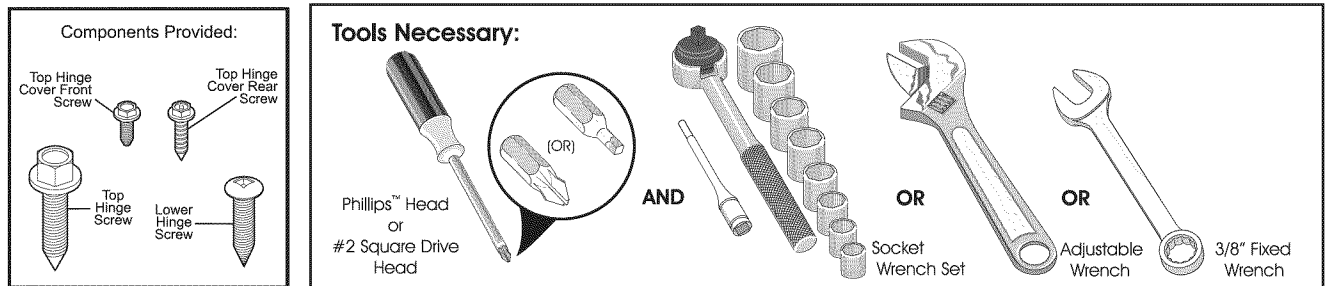

This Use & Care Guide provides general installation and operating instructions for your model. We recommend using a service or kitchen contracting professional to install your refrigerator. Use the refrigerator only as instructed in this Use & Care Guide. **Before starting the refrigerator, follow these important first steps.**

## Location

- Choose a place that is near a grounded, non-GFCI, electrical outlet. **Do Not** use an extension cord or an adapter plug.
- If possible, place the refrigerator out of direct sunlight and away from the range, dishwasher, or other heat sources.
- The refrigerator must be installed on a floor that is level and strong enough to support a fully loaded refrigerator.
- Consider water supply availability for models equipped with an automatic ice maker.

## CAUTION

**DO NOT** install the refrigerator where the temperature will drop below 55°F (13°C) or rise above 110°F (43°C). The compressor will not be able to maintain proper temperatures inside the refrigerator.

**DO NOT** block the toe grille on the lower front of your refrigerator. Sufficient air circulation is essential for the proper operation of your refrigerator.

## Installation

- Allow the following clearances for ease of installation, proper air circulation, and plumbing and electrical connections:

Sides & Top	3/8 inch (9.5 mm)
Back	1 inch (25.4 mm)

## NOTE

If your refrigerator is placed with the door hinge against a wall, you may have to allow additional space so the door can be opened wider.

## Door opening

## NOTE

The refrigerator doors are designed to shut by themselves within a 20 degree opening.

Your refrigerator should be positioned to allow easy access to a counter when removing food. For best use of refrigerator drawers and freezer baskets, the refrigerator should be in a position where both can be fully opened.

## Freezer Drawer Alignment (if necessary)

- 1 Check gasket seal around top, bottom, and sides of freezer drawer.
- 2 If gasket is not sealed, open drawer and slightly loosen four (4) drawer screws (two (2) on each side) to allow drawer to rotate.
- 3 Close drawer and recheck the seal on the gasket (A). Open the drawer grabbing by the sides in the center (B). Be careful not to rotate the drawer.

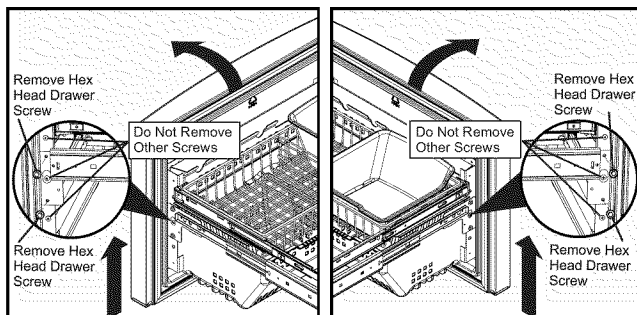

- 4 Tighten four (4) drawer screws.
- 5 Recheck gasket seal.

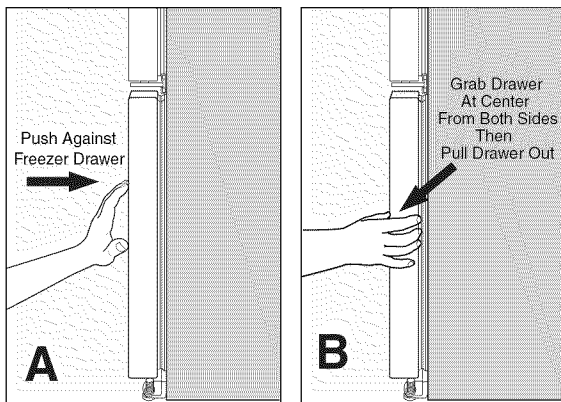

## Cabinet Leveling & Refrigerator Door Alignment (if necessary)

### Guidelines for final positioning of your refrigerator:

- All four corners of the cabinet must rest firmly on the floor.
- The sides should tilt  $\frac{1}{4}$  inch (6 mm) from front to back (to ensure that doors close and seal properly).
- Doors should align with each other and be level.

Most of these conditions can be met by raising or lowering the adjustable front rollers.

### To level the cabinet using the front rollers:

- 1 Slightly open freezer drawer. Lift the toe grille and gently pull forward (see illustration).
- 2 You can raise or lower each door. Use a  $\frac{3}{8}$  inch socket wrench to turn the adjustment screws (1 per side).

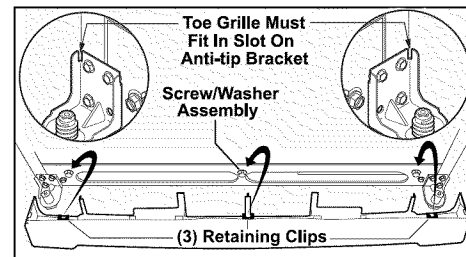

To raise: turn adjustment screw clockwise.

To lower: turn adjustment screw counterclockwise.

- 3 Ensure both doors are bind-free with their seals touching the cabinet on all four sides and that cabinet is stable.
- 4 After unit is leveled, lower anti-tip leg until it contacts the floor.

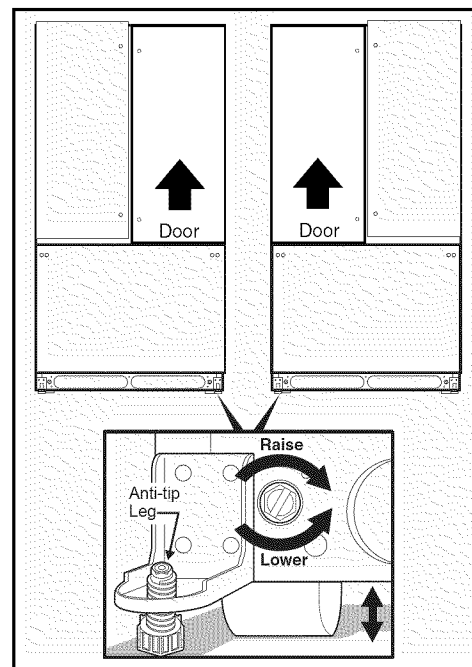

- 5 Install the toe grille by fitting into place.

# 8 Installation

## To adjust the door stop:

Door stop is adjustable between 85 to 145 degrees.

### NOTE

View shown is looking up at the bottom of the refrigerator door.

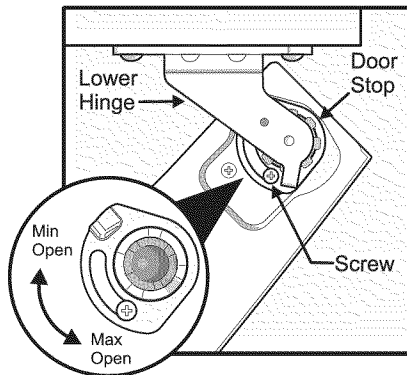

Adjustable Door Stop

- 1 Open door to provide access to screw.
- 2 Loosen screw.
- 3 Adjust door to desired location.

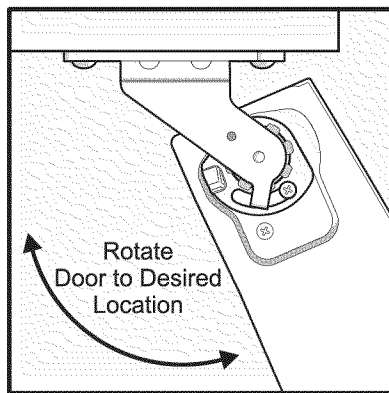

Adjusting Door

- 4 Rotate door stop until it makes contact with the lower hinge.

- 5 Retighten screw.

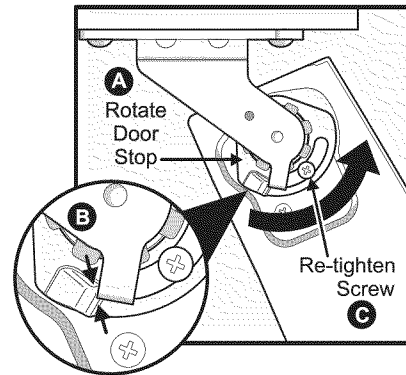

Retighten Screw

- 6 Ensure door stops in desired location before resuming normal use.

## To level the doors using the adjustable lower hinge (select models):

- 1 Remove all food items from door bins on door being adjusted.
- 2 Open doors to 90 degrees.
- 3 Loosen or remove screw.

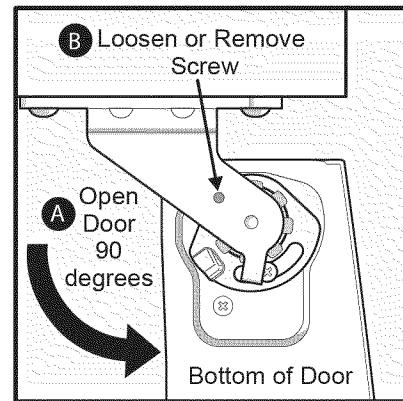

Loosen/Remove Screw (where applicable)

### NOTE

Adjustable hinge should only be used after doors have been leveled with rollers.



- Lift the door while adjusting the washer. To raise the door, rotate washer clockwise (when viewed from the bottom). To lower door, rotate washer counterclockwise (when viewed from the bottom).

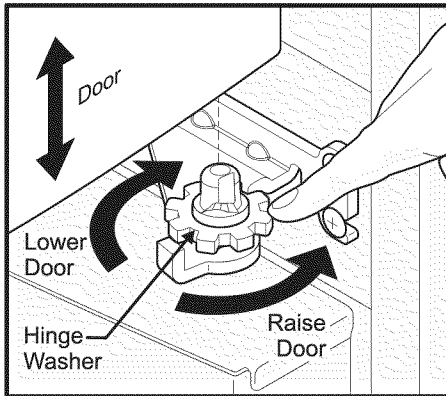

**Raising/Lowering Door**

- Retighten the screw, where applicable, ensuring it is between the spokes of the set washer. Screw will not be tight, just insert until it is flush with the hinge.

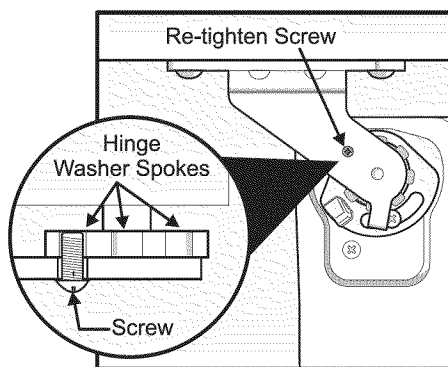

**Screw (where applicable)**

## NOTE

If after adjusting doors higher the door makes a popping/clicking sound, remove screw and replace with the longer one supplied in the handle package.

### To adjust the flipper mullion:

- Loosen the screw located on the flipper mullion hinge.

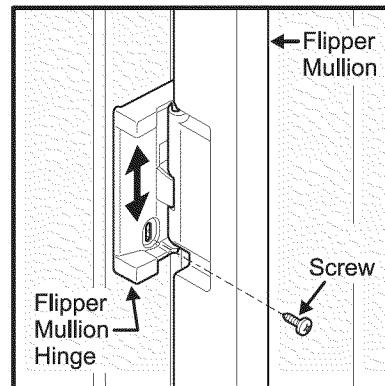

**Adjusting Flipper Mullion Screw**

- Adjust flipper mullion height. For proper connection with the flipper mullion guide, there should be a separation about the thickness of a coin (0.060 inches, or 1.5 mm) between the guide and flipper mullion.

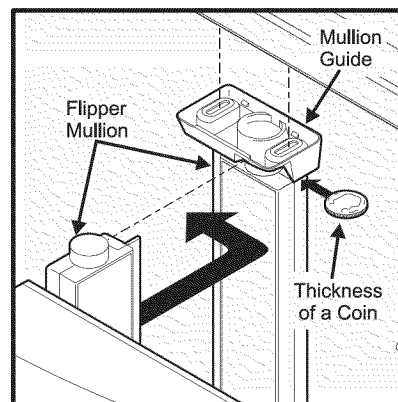

**Adjusting Flipper Mullion Height**

- Retighten screw.

# 10 Installation

## Installing Shelves

Your refrigerator was shipped with the shelf hanger and shelf locking clip installed in their shipping position. Below are the instructions to install the shelves in your desired locations.

- 1 Remove shelf from its locked position by pulling the slide mechanism toward you.

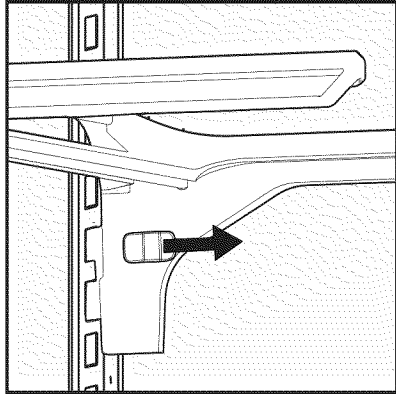

- 2 Lift the hanger directly upwards and pull toward you to remove it from the ladder.

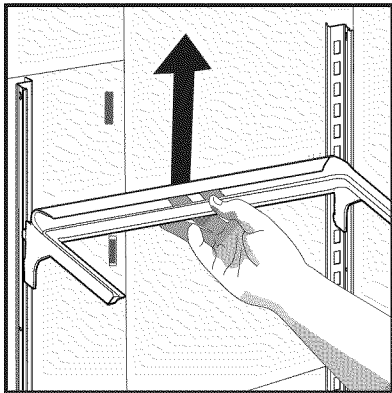

- 3 Place top hooks of the hanger into the desired slot, and lower straight down until lower hooks rest on the ladder.

### CAUTION

Shelves must be removed prior to moving the refrigerator.

- 4 Relock shelf by pushing the slide mechanism away from you.

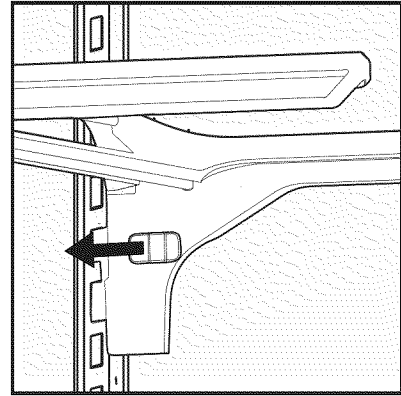

- 5 While holding shelf at a 45-degree angle with the gray handle facing you, push the shelf into the back of the hanger.

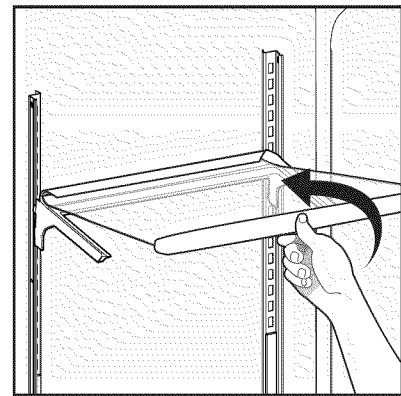

- 6 Gently set the shelf onto the hanger once the back is secured by the hanger.

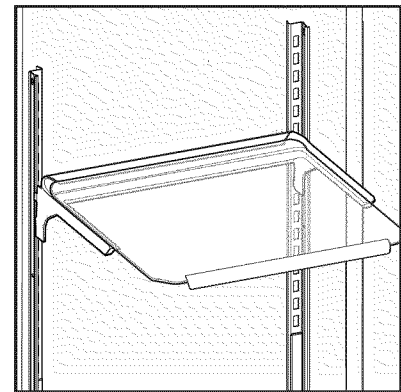

## Getting through narrow spaces

If your refrigerator will not fit through an entrance area, you can remove the doors. Check first by measuring the entrance.

### To prepare for removing the doors:

- 1 Make sure the electrical power cord is unplugged from the wall outlet.
- 2 Open the freezer drawer and remove the toe grille (see "Installation" section).
- 3 Remove any food from the door shelves and close the doors.

### To remove the refrigerator doors:

- 1 Trace lightly around the door's top hinges with a pencil. This makes reinstallation easier.

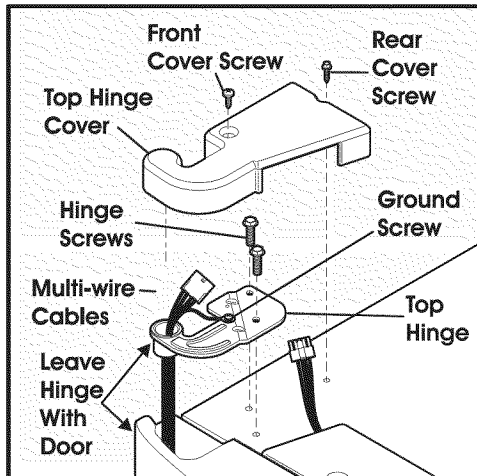

- 2 Disconnect the harness by grasping both sides of the connector firmly, depress the latch, and pull apart. Remove the two (2) screws from the top hinge. Lift the door off of the bottom hinge and set it aside.

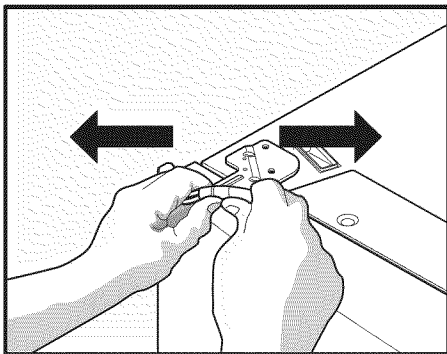

- 3 Unscrew the three (3) lower hinge screws and hinge if necessary.

To reinstall the right door, reverse the above steps.

### Lower Hinge Removal

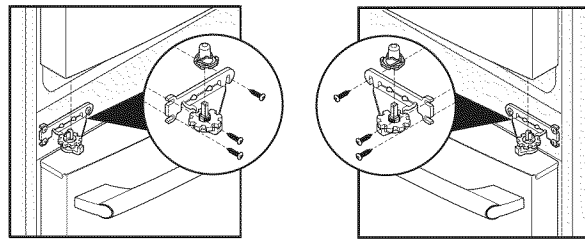

Once both doors are in place, ensure they are aligned with each other and level (please see the "Installation" section for more details), and replace the top hinge cover.

### **CAUTION**

Be sure doors are set aside in a secure position where they cannot fall and cause personal injury, or damage to the doors or handles.

### Removing Freezer Drawer

- 1 Open freezer drawer.
- 2 Remove drawer screws on right and left sides (two (2) screws on each side).

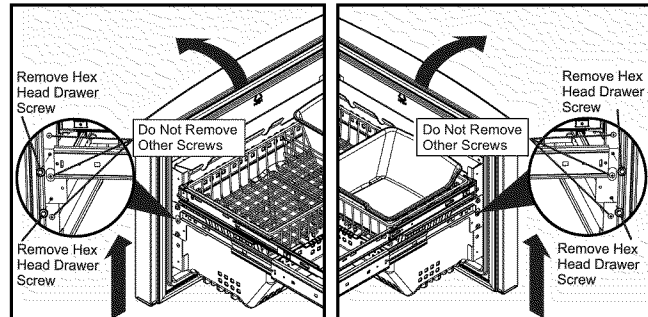

### **CAUTION**

Drawer is heavy. Use caution when lifting.

- 3 Lift drawer up and out to remove.

# 12 Removing the Doors

## Installing Freezer Drawer

- 1 With lower slides pulled out, hang drawer onto slide brackets ensuring pins on each side are fully inserted into slots on each side.

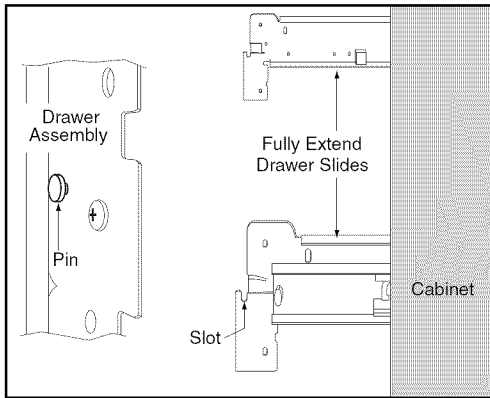

- 2 Reinstall four (4) drawer screws (two (2) per side), tighten down, and close drawer (C).

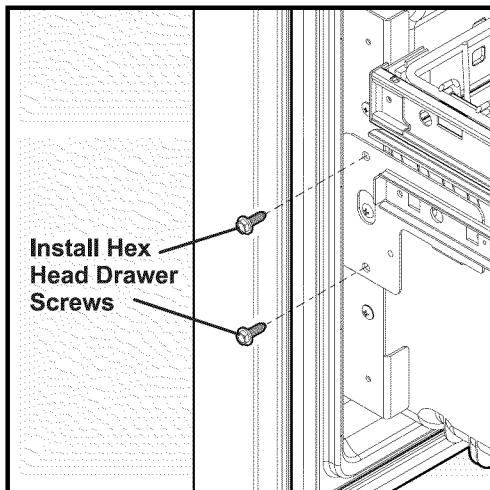

- 3 Check gasket seal around top, bottom, and sides of freezer drawer.
- 4 If gasket is not sealed, open drawer and slightly loosen four (4) drawer screws (two (2) on each side) to allow drawer to rotate.
- 5 Close drawer and recheck the seal on the gasket (A). Open the drawer grabbing by the sides in the center (B). Be careful not to rotate the drawer.

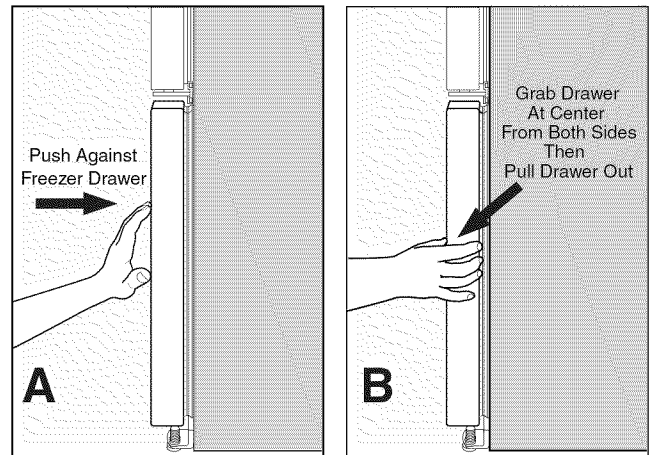

- 6 Tighten four (4) drawer screws.
- 7 Recheck gasket seal.
- 8 Install the toe grille by fitting into place.

## Door Handle Mounting Instructions

- 1 Remove handles from protective packaging.
- 2 Position fresh food handle end caps (A) over upper and lower pre-installed shoulder bolts (B) that are fastened into door, ensuring the holes for the set screws are facing towards the opposite door.
- 3 While holding handle firmly against door, fasten upper and lower Allen set screws (C) with supplied Allen wrench.
- 4 Repeat steps 2 and 3 to install opposite handle. Ensure the holes for the set screws are facing towards the first door.
- 5 Position freezer handle end caps over left and right pre-installed shoulder bolts that are fastened to the drawer, ensuring the holes for the set screws are facing down.
- 6 While holding handle firmly against drawer, fasten left and right Allen set screws (C) with supplied Allen wrench.

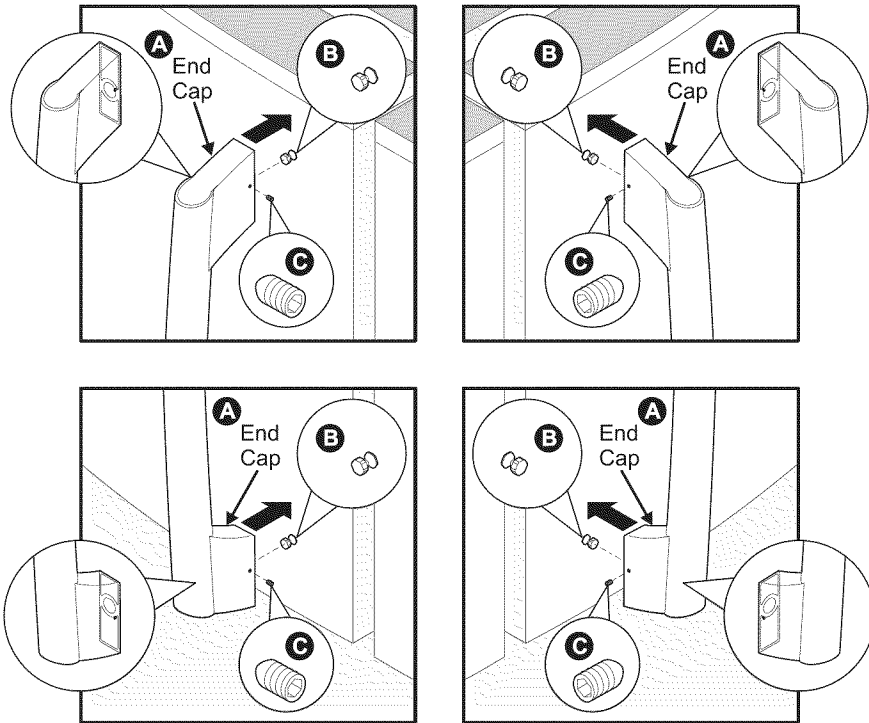

Mounting Refrigerator Handles

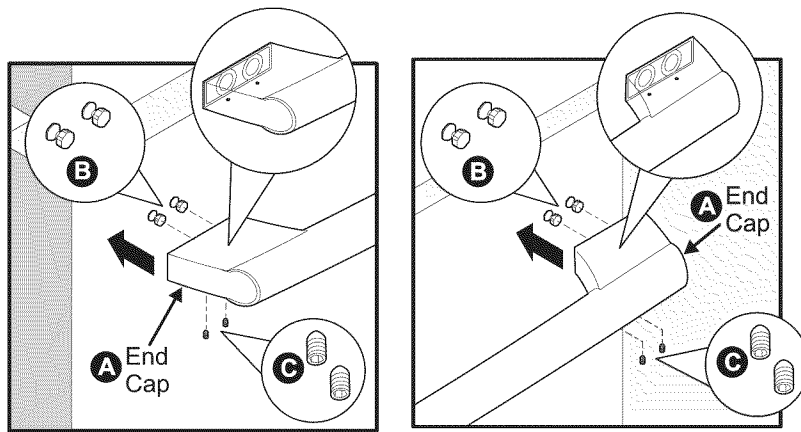

Mounting Freezer Handle

### NOTE

To ensure that handles are flush with doors/drawer, make sure that set screws are completely tightened.

# 14 Connecting the Water Supply

## WARNING

To avoid electric shock, which can cause death or severe personal injury, disconnect the refrigerator from electrical power before connecting a water supply line to the refrigerator.

## CAUTION

To Avoid Property Damage:

- Copper or Stainless Steel braided tubing is recommended for the water supply line. Water supply tubing made of ¼ inch plastic is not recommended to be used. Plastic tubing greatly increases the potential for water leaks, and the manufacturer will not be responsible for any damage if plastic tubing is used for the supply line.
- DO NOT install water supply tubing in areas where temperatures fall below freezing.
- Chemicals from a malfunctioning softener can damage the ice maker. If the ice maker is connected to soft water, ensure that the softener is maintained and working properly.

## IMPORTANT

Ensure that your water supply line connections comply with all local plumbing codes.

**Before installing the water supply line, you will need:**

- Basic Tools: adjustable wrench, flat-blade screwdriver, and Phillips™ screwdriver
- Access to a household cold water line with water pressure between 30 and 100 psi.
- A water supply line made of ¼ inch (6 mm) OD, copper or stainless steel tubing. To determine the length of tubing needed, measure the distance from the ice maker inlet valve at the back of the refrigerator to your cold water pipe. Then add approximately 7 feet (2.1 meters), so the refrigerator can be moved out for cleaning (as shown).
- A shutoff valve to connect the water supply line to your household water system. DO NOT use a self-piercing type shutoff valve.
- Do not reuse compression fitting or use thread seal tape.
- A compression nut and ferrule (sleeve) for connecting a copper water supply line to the ice maker inlet valve.

## NOTE

Check with your local building authority for recommendations on water lines and associated materials prior to installing your new refrigerator. Depending on your local/state building codes, Electrolux recommends for homes with existing valves its Smart Choice® water line kit 5305513409 (with a 6 ft. Stainless Steel Water Line) and for homes without an existing valve, Electrolux recommends its Smart Choice water® line kit 5305510264 (with a 20 ft. Copper Water Line with self-tapping saddle valve). Please refer to [www.electroluxappliances.com](http://www.electroluxappliances.com) for more information.

**To connect water supply line to ice maker inlet valve:**

1. Disconnect refrigerator from electric power source.
2. Place end of water supply line into sink or bucket. Turn ON water supply and flush supply line until water is clear. Turn OFF water supply at shutoff valve.
3. Remove plastic cap from water valve inlet and discard cap.
4. **If you use copper tubing** - Slide brass compression nut, then ferrule (sleeve) onto water supply line. Push water supply line into water valve inlet as far as it will go (¼ inch / 6 mm). Slide ferrule (sleeve) into valve inlet and finger tighten compression nut onto valve. Tighten another half turn with a wrench; DO NOT overtighten. See Figure 1.  
**If you use stainless steel tubing** - The nut and ferrule are already assembled on the tubing. Slide compression nut onto valve inlet and finger tighten compression nut onto valve. Tighten another half turn with a wrench; DO NOT overtighten. See Figure 2.
5. With steel clamp and screw, secure water supply line (copper tubing only) to rear panel of refrigerator as shown.
6. Coil excess water supply line (copper tubing only), about 2½ turns, behind refrigerator as shown and arrange coils so they do not vibrate or wear against any other surface.
7. Turn ON water supply at shutoff valve and tighten any connections that leak.
8. Reconnect refrigerator to electrical power source.
9. To turn ice maker on, lower wire signal arm (freezer ice maker) or set the ice maker's On/Off power switch to the "ON" position (fresh food ice maker).

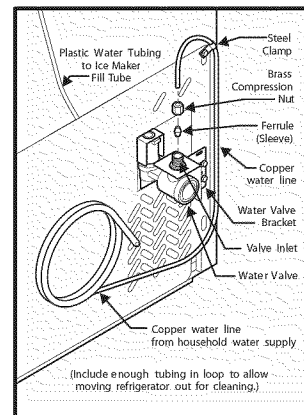

Figure 1

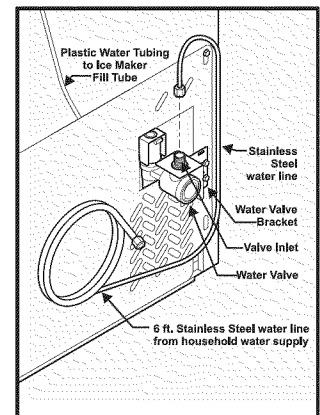
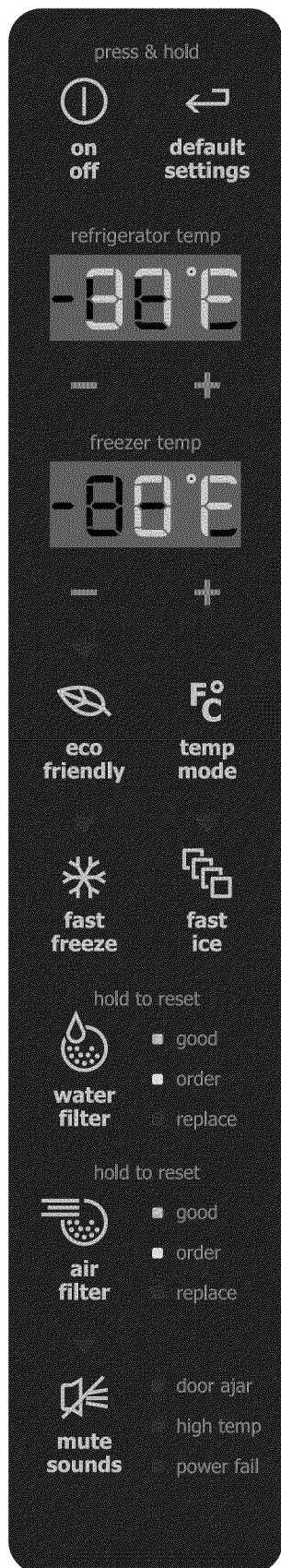

Figure 2



## IQ-Touch™

An indicator light will be illuminated above most active features.

Touch the icon to activate the options below.

### NOTE

\*Features may vary according to model.

- fast freeze** Activates a faster rate for freezing food.
- fast ice** Increases the production of ice
- water filter** Press and hold for three (3) seconds to reset after filter change.
- air filter** Filter condition status is always displayed when door is open. Press and hold for three (3) seconds to reset after filter change.
- temp mode** Touch to toggle display from Fahrenheit to Celsius.
- mute sounds** Tones emitted by each key press can be turned off based on user preference. The sounds are muted when the red indicator is lit. Warning signals will stay active.
- default settings** Resets all refrigerator settings such as temp, temp display and tones to their factory default settings.
- on off** Press and hold for three (3) seconds to turn off the cooling system to clean the refrigerator. It also turns off the ice maker. The temperature displays will read OFF.
- eco friendly** Keep this switch set on eco friendly (light on) for lowest energy usage. If moisture appears on the cabinet between the doors, pressing this button will turn the light off and enable an electric heater used to reduce moisture on the cabinet between the doors.
- \*vacation mode** Conserves energy by increasing the time between automatic defrost. This feature is automatically activated during long periods between door openings. Vacation mode is manually activated when the red indicator is lit.

### IMPORTANT

Pressing the **system on/off** icon does not turn off power to your refrigerator. You must unplug the power cord from the wall outlet.

#### Setting cooling temperatures

Press the + or – indicator to adjust the temperature to the desired setting.

The temperature display will begin to blink with the first touch. The display will time out after 10 seconds and return to the basic display.

#### Alarms

- Door Ajar** If the door has been left open for an extended period of time, an alarm will sound and the door ajar indicator will display on the bottom display of the control panel. The alarm is turned off by closing the door. The mute sounds key will blink to prompt the reset of any active alarms. Press this key to reset any system alarms.
- High Temp** In the event of a high temperature condition, the temperature display will blink and display **HI**. After 20 minutes, the alarm will sound and the **high temp** indicator will be red on the bottom of the control panel. The **mute sounds** icon will illuminate until pressed, acknowledging the alarm, at which time the highest temperature reached will be displayed and the refrigerator will resume normal operation. In case the high temp alarm is not acknowledged at the first alarm sound time out, when the door is first opened, the alarm sound will be repeated.
- Power Fail** In the event of a power failure, the **power fail** alert will be displayed and the temperature display will blink until the **mute sounds** icon is pressed, acknowledging the alarm. Other modes may be turned off until the alarm is acknowledged. The **power fail** alert is turned off and the refrigerator will resume normal operation. **The high temp alarm may also be illuminated until a safe operating range temperature has been reached.**

# 16 Controls

## IQ-Touch™ Sabbath Mode

The Sabbath Mode is a feature that disables portions of the refrigerator and its controls for IQ-Touch™, in accordance with observance of the weekly Sabbath and religious holidays within the Orthodox Jewish community.

Sabbath Mode is turned ON and OFF by pressing and holding the freezer temp “-” and the refrigerator temp “+” indicators for five (5) seconds. The display shows “Sb” while in Sabbath mode.

In the Sabbath Mode, the High Temp alarm is active for health reasons. If a high temperature alarm is activated during this time, for example due to a door left ajar, the alarm will sound intermittently for about two (2) minutes. The alarm will then silence on its own and a red high temperature icon will display. The high temp icon will continue to display, even if the door is closed, until the Sabbath mode is exited and the icon reset. The refrigerator will function normally once the door is closed, without any violation of the Sabbath/Holidays.



For further assistance, guidelines for proper usage and a complete list of models with the Sabbath feature, please visit the web at <http://www.star-k.org>.



### NOTE

While in Sabbath Mode, neither the lights nor the control panel will work until Sabbath Mode is deactivated.

Refrigerator stays in Sabbath Mode after power failure recovery. It must be deactivated with the buttons on the control panel.



### NOTE

During Sabbath Mode, the ice maker is turned off by main control board.

### Sabbath Mode and the Perfect Temp™ Drawer

The Perfect Temp™ Drawer should be turned off for the Sabbath/Holidays. Before putting the refrigerator into the Sabbath mode, turn the Perfect Temp™ Drawer off by pressing the drawer **on/off** button. The display will show **OFF** and the drawer will turn off. Then enter the Sabbath mode function on the main refrigerator display. See the **IQ-Touch Sabbath Mode** section. When in Sabbath mode, the display will not illuminate and the drawer will remain off. The drawer can still be used as a non-temp controlled drawer in this mode. When the refrigerator is taken out of Sabbath mode, the Perfect Temp™ Drawer will have to be turned back on.



### NOTE

If the Perfect Temp™ Drawer is not turned off prior to putting the unit into Sabbath Mode, it will continue to adjust itself to maintain the set point even if the display does not illuminate to show that it is still on.



## Ice maker operation & care

After the refrigerator is installed properly, the ice maker can produce ice within 24 hours. It can completely fill an ice bin in about three (3) days.

When using the ice maker for the first time and in order for the ice maker to work properly, it is necessary to clear air from water filter tubing. Once ice maker begins making ice, allow the bucket to fill completely, then discard the first TWO (2) FULL buckets of ice. It will take at least two (2) days to completely fill the bucket on regular ice making mode or 1 1/2 days on fast ice mode.

The ice maker produces approximately four (4) pounds of ice every 24 hours depending on usage conditions.

### ➔ IMPORTANT

Your ice maker is turned on at the factory so it can work as soon as you install your refrigerator. If you cannot connect a water supply, lift the ice maker's wire signal arm to turn it off. Otherwise, the ice maker's fill valve may make a loud chattering noise when it attempts to operate without water.

### Turning the ice maker on and off

Ice production is controlled by lifting/lowering the ice maker's **wire signal arm**. To gain access to the ice maker, pull the freezer drawer out. Lift the wire signal arm to turn the ice maker OFF and lower the wire signal arm to turn it ON.

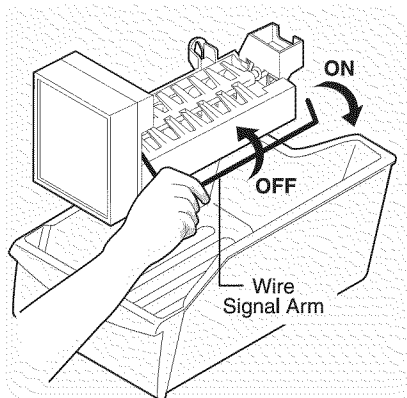

### Ice maker tips

- If your refrigerator is not connected to a water supply or the water supply is turned off, turn off the ice maker by lifting wire signal arm.

- The following sounds are normal when the ice maker is operating:
  - Motor running
  - Ice dropping into ice bin
  - Water valve opening or closing
  - Running water
- Ice cubes stored too long may develop an odd flavor. Empty the ice bin as explained below.

### Fast Ice Function

Your refrigerator is equipped with a Smart Fast Ice Function, that will, if activated at your user interface, allow an increase in ice production. You do not need to deactivate it, if not needed, your refrigerator will operate on normal conditions.

### ⚠ CAUTION

**If the water supply to your refrigerator is softened, be sure the softener is properly maintained. Chemicals from a water softener can damage the ice maker.**

### Cleaning the ice maker

Clean the ice maker and ice bin at regular intervals, especially prior to vacation or moving.

- 1 Turn off the ice maker.
- 2 Remove the ice bin.
- 3 Empty and carefully clean the ice bin with mild detergent. Do not use harsh or abrasive cleaners. Rinse with clean water.
- 4 Allow the ice bin to dry completely before replacing in the freezer.
- 5 Replace the ice bin. Turn the ice maker on.

Remove and empty the ice bin if:

- An extended power failure (one hour or longer) causes ice cubes in the ice bin to melt and freeze together.

Remove the ice bin and shake to loosen the cubes or clean as explained above.

### ⚠ CAUTION

**NEVER use an ice pick or similar sharp instrument to break up the ice. This could damage the ice bin.**

**To loosen stuck ice, use warm water. Before replacing the ice bin, make sure it is completely dry.**

# 18 Storage Features

## Shelf features



### CAUTION

To avoid injury from breakage, handle tempered glass shelves carefully.



### NOTE

Features may vary according to model.

### To change the position of a shelf:

- 1 Remove shelf from its locked position by pulling the slide mechanism toward you.

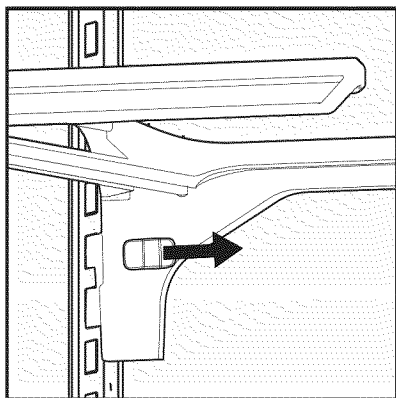

- 2 Lift the hanger directly upwards and pull toward you to remove it from the ladder.

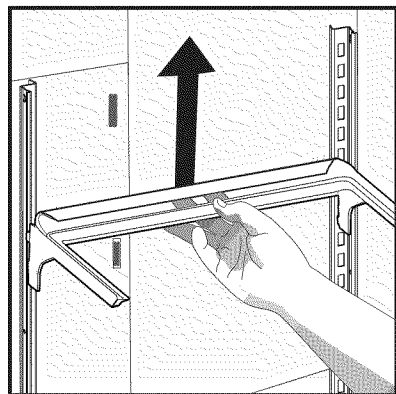

- 3 Place top hooks of the hanger into the desired slot, and lower straight down until lower hooks rest on the ladder.



### CAUTION

Shelves must be removed prior to moving the refrigerator.

- 4 Relock shelf by pushing the slide mechanism away from you.

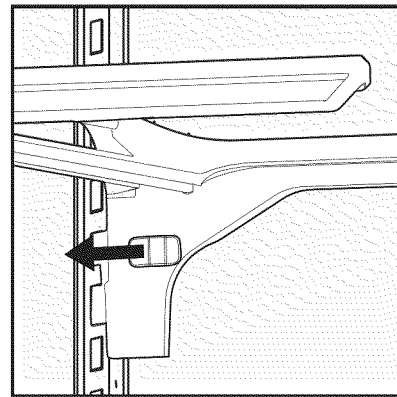

- 5 While holding shelf at a 45-degree angle with the gray handle facing you, push the shelf into the back of the hanger.

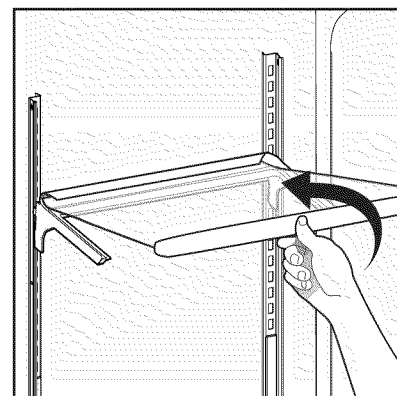

- 6 Gently set the shelf onto the hanger once the back is secured by the hanger.

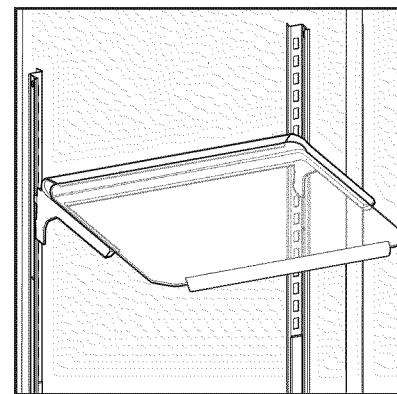

## Drawers

Your refrigerator includes a variety of storage drawers. These drawers are located in fixed positions at the bottom of the fresh food compartment.

### Luxury Glide™ Crispers

Crisper drawers are designed for storing fruits, vegetables, and other fresh produce. They feature a smooth-glide, ball-bearing and soft-close functionality so as not to bruise fruits and vegetables.

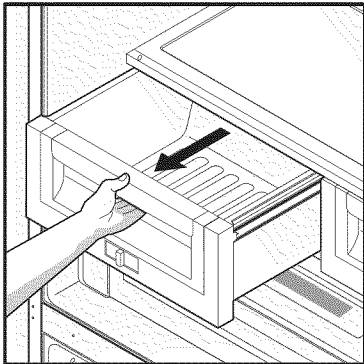

Opening Crisper Drawer

### Crisper humidity control

Crisper drawers include a sliding control for adjusting the humidity inside the crisper. Leafy vegetables keep best when stored with the Humidity Control set on Higher Humidity. Fresh fruits keep best when stored with the Humidity Control set on Lower Humidity.

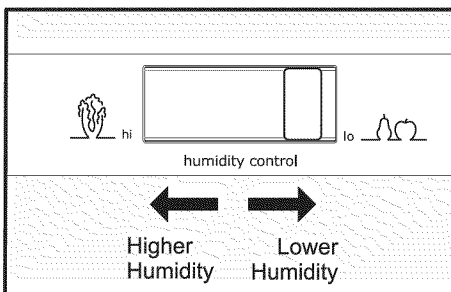

Adjusting Crisper Humidity  
(select models)

To remove the Crisper Drawer for cleaning:

- 1 Pull the drawer out until it stops.
- 2 Lift the front slightly and remove the drawer.

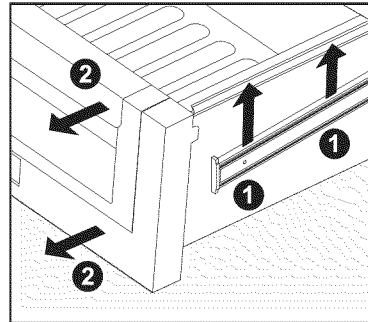

Removing Crisper Drawer

### Special item mat (select models)

The innovative design of the special item mat allows you to store four (4) bottles of wine or soft drink bottles, or any item that you want to prevent moving around.

### Cool Zone™ Drawer (select models)

Some models are equipped with a drawer for short-term storage of bulk items. This drawer includes sliding controls for adjusting the humidity inside.

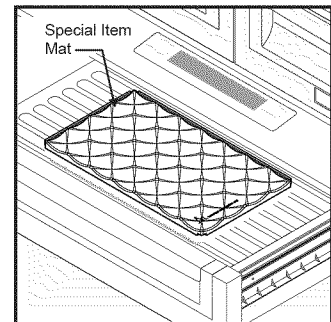

### NOTE

Any meat to be kept longer than two (2) days should be frozen. If you store fruits or vegetables in this drawer, set it to a higher humidity.

# 20 Storage Features

## Perfect Temp™ Drawer (select models)

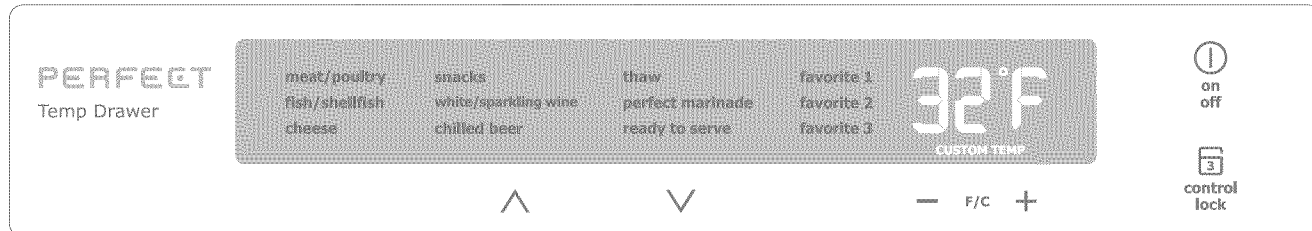

The Perfect Temp™ Drawer is designed to keep food items at a precise temperature whether cooler, warmer, or the same as the fresh food section of the refrigerator. This drawer features a smooth-glide, ball bearing system and soft-close functionality so as not to bruise your fruits and vegetables. The thaw setting holds a temperature for thawing frozen foods for 12 hours. At the end of that time, it then switches to the snacks setting to store the thawed food.

### To operate:

- 1 To turn on and off, press the drawer's **On/Off** button. The numeric display will show a temperature between **28°F and 42°F** when on and **OFF** when off.
- 2 Press **F/C** if you prefer to display Fahrenheit (F), or Celsius (C).
- 3 Press either the up ^ or down v scroll buttons to illuminate the desired item.
- 4 Once an option is selected, the drawer will adjust and maintain the temperature for the setting selected.
- 5 When turned off, the Perfect Temp™ Drawer functions as a standard deli drawer. The Perfect Temp™ Drawer is best used for packaged food products. Leafy vegetables and unpackaged fruits are best kept in one of the crisper drawers.
- 6 The three favorite selections provide flexibility to set and store personal temperature selections. The temperature is adjusted up by pressing the + or – buttons. The drawer will store the selected temperature setting until it is changed.
- 7 The control buttons can be locked to prevent accidental changes by pressing the **control lock** button for three (3) seconds. Deactivate by pressing for three (3) seconds again.

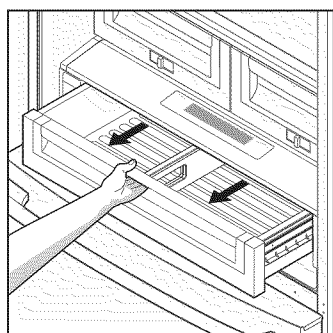

Opening the Drawer

### ▶ IMPORTANT

DO NOT clean the display area of the Perfect Temp™ Drawer with abrasive or caustic cleaners. Wipe clean with a moist sponge.

### ⚠ CAUTION

The Perfect Temp™ Drawer and cover can be removed for cleaning but the control unit, attached to the right side of the fridge, cannot be removed. Do not immerse the Perfect Temp™ Drawer cover in water or put it in a dishwasher. Clean with a damp cloth or sponge.

### To remove the Perfect Temp™ Drawer for cleaning:

- 1 Pull the drawer out until it stops.
- 2 Lift the front slightly and remove the drawer.

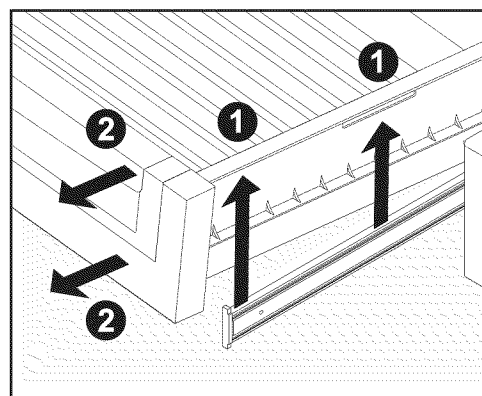

Removing the Drawer

### 🗨 NOTE

When the refrigerator is turned off by pressing the main IQ-Touch™ on/off button, the Perfect Temp™ Drawer will also be turned off. When the refrigerator is turned back on, the Perfect Temp™ Drawer will resume operations at the temp setting that was set before the refrigerator was turned off.

## Doors

### Storage bins

The doors to your fresh food compartment use a system of modular storage bins. All of these bins are removable for easy cleaning. Some of them have fixed positions, while others can be adjusted to your needs.

Door bins are ideal for storing jars, bottles, cans, and large drink containers. They also enable quick selection of frequently used items.

#### To change the position of an adjustable door bin:

- 1 Before adjusting a bin, remove all food.
- 2 Grip the bin firmly with both hands and lift it upward.
- 3 Remove the bin.
- 4 Place the bin just above desired position.
- 5 Lower the bin onto supports until locked in place.

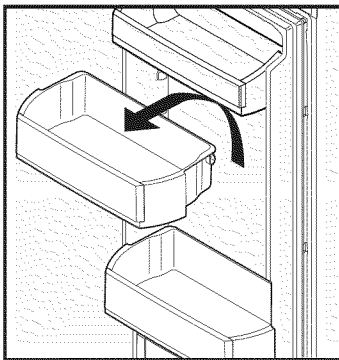

Adjustable Door Bin

## Accessories (varies by model)

### Tilt can bins

The can bins allow you to efficiently and securely store up to eight 12-ounce canned beverages.

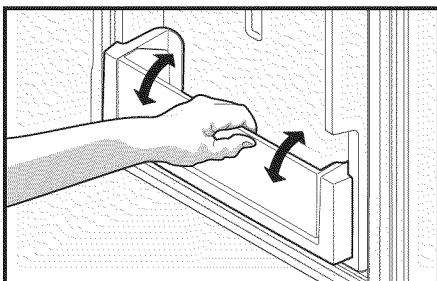

Tilt Can Bin

## Freezer Features (varies by model)

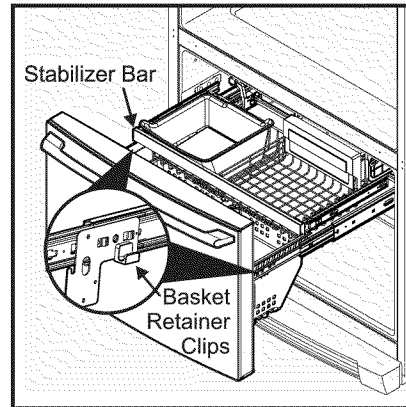

Two Freezer Baskets

#### To Remove Upper Basket

- 1 Remove all items from basket.
- 2 Remove basket by pulling basket out to its full extension and lift out.

To reinstall upper basket, position basket onto the retainer clips making sure the front of the basket rests in the retainer clips on the stabilizer bar.

#### NOTE

If basket is not resting on stabilizer bar retainer clips, the drawer will not close properly.

#### To Remove Lower Basket

- 1 Remove all items from basket.
- 2 Remove the basket by tilting it forward and lifting it from the retainer clips.

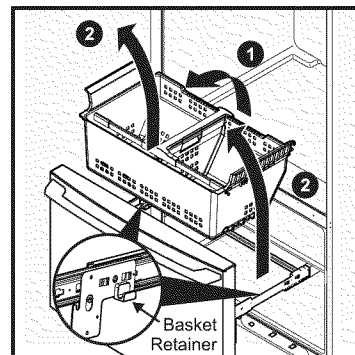

Removing Lower Basket

To reinstall lower basket, insert basket into retainer clips.

# 22 Storage Features

## Soft Serve Bin

The soft serve bin in the upper right corner is designed to maintain temperatures a few degrees above the freezer temperature. This is perfect for storing items that need a softer texture in order to easily serve, items such as ice cream.

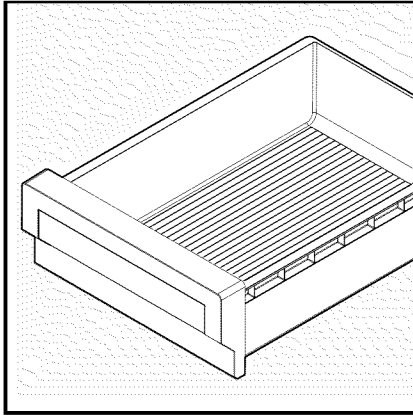

Squeeze handle and lift up in the center of the divider to move it side-to-side. (The divider cannot be removed.)

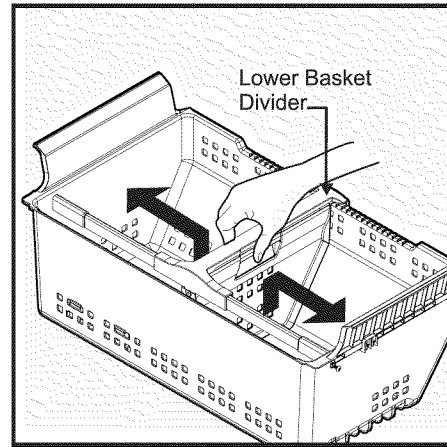

Plastic Lower Basket Divider

## Dividers Removal

Lift up on the front of the middle divider and pull out.

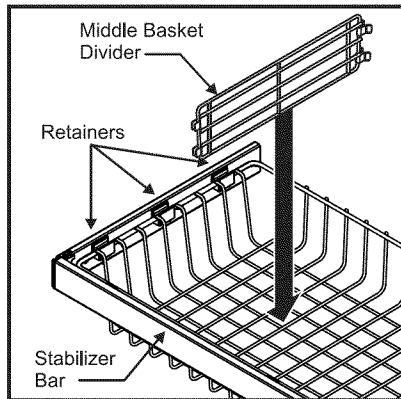

Wire Middle Basket Divider

## NOTE

Spill Guard Tray should be hand washed in warm water.

## Ideas for storing foods

### Fresh food storage

- Keep the fresh food compartment between 34° F and 40° F with an optimum temperature of 37° F.
- Avoid overcrowding the refrigerator shelves, which reduces air circulation and causes uneven cooling.

### Fruits and vegetables

- Store fruits and vegetables in crisper drawers, where trapped moisture helps preserve food quality for longer time periods.
- Wash items and remove excess water.
- Wrap any items that have strong odors or high moisture content.

### Meat

- Wrap raw meat and poultry separately and securely to prevent leaks and contamination of other foods or surfaces.
- Use the Cool Zone™ or Perfect Temp™ drawer and set to meat/poultry setting for short-term storage. Any meat to be kept longer than two (2) days should be frozen.

### Frozen food storage

- Keep the freezer compartment at 0° F or lower.
- A freezer operates most efficiently when it is at least  $\frac{2}{3}$  full.

### Packaging foods for freezing

- To minimize food dehydration and quality deterioration, use aluminum foil, freezer wrap, freezer bags, or airtight containers. Force as much air out of the packages as possible and seal them tightly. Trapped air can cause food to dry out, change color, and develop an off-flavor (freezer burn).
- Wrap fresh meats and poultry with suitable freezer wrap prior to freezing.
- Do not refreeze meat that has completely thawed.

### Loading the freezer

- Prior to grocery shopping, activate **fast freeze** so that on your return you can ensure your newly purchased food designated for the freezer will be preserved as quickly as possible.
- Activating **fast freeze** also will help your freezer more efficiently maintain the selected temperature after placing new purchases with pre-existing frozen foods.

- Avoid adding too much warm food to the freezer at one time. This overloads the freezer, slows the rate of freezing, and can raise the temperature of frozen foods.
- Leave a space between packages, so cold air can circulate freely, allowing food to freeze as quickly as possible.

## Ideas for saving energy

### Installation

- Locate the refrigerator in the coolest part of the room, out of direct sunlight, and away from heating ducts or registers.
- Do not place the refrigerator next to heat-producing appliances such as a range, oven, or dishwasher. If this is not possible, a section of cabinetry or an added layer of insulation between the two (2) appliances will help the refrigerator operate more efficiently.
- Level the refrigerator so that the doors close tightly.

### Temperature settings

- Refer to the **Controls** section for procedures on temperature settings.

### Food storage

- Avoid overcrowding the refrigerator or blocking cold air vents. Doing so causes the refrigerator to run longer and use more energy.
- Cover foods and wipe containers dry before placing them in the refrigerator. This cuts down on moisture build-up inside the unit.
- Organize the refrigerator to reduce door openings. Remove as many items as needed at one time and close the door as soon as possible.
- Do not place a hot container directly on a cold shelf. Remember, such an extreme temperature change may damage the glass.

# 24 Normal Operating Sounds

## Understanding the sounds you may hear

Your new, high-efficiency refrigerator may introduce unfamiliar sounds. These sounds normally indicate your refrigerator is operating correctly. Some surfaces on floors, walls, and kitchen cabinets may make these sounds more noticeable.

The following is a list of major components in your refrigerator and the sounds they can cause:

- A Evaporator** Refrigerant through the evaporator may create a boiling or gurgling sound.
- B Evaporator fan** You may hear air being forced through the refrigerator by the evaporator fan.
- C Defrost heater** During defrost cycles, water dripping onto the defrost heater may cause a hissing or sizzling sound. After defrosting, a popping sound may occur.
- D Automatic ice maker** When ice has been produced, you will hear ice cubes falling into the ice bin. Water valve activation may create sounds from its operation.
- E Electronic control & automatic defrost control** These parts can produce a snapping or clicking sound when turning the cooling system on and off.
- F Condenser fan** You may hear air being forced through the condenser.
- G Compressor** Modern, high-efficiency compressors run much faster than older models. The compressor may have a high-pitched hum or pulsating sound.
- H Water valve** Makes a buzzing sound each time it opens to fill the ice maker.
- I Drain pan** (not removable) You may hear water dripping into the drain pan during the defrost cycle.
- J Condenser** May create minimal sounds from forced air.
- K Motorized Perfect Temp™ drawer damper** May produce a light humming during operation.
- M Motorized damper** May produce a light humming during operation.
- N Perfect Temp™ drawer fan** Turns off when door opens or Perfect Temp™ drawer is turned off.

### NOTE

Energy efficient foam in your refrigerator is not a sound insulator.

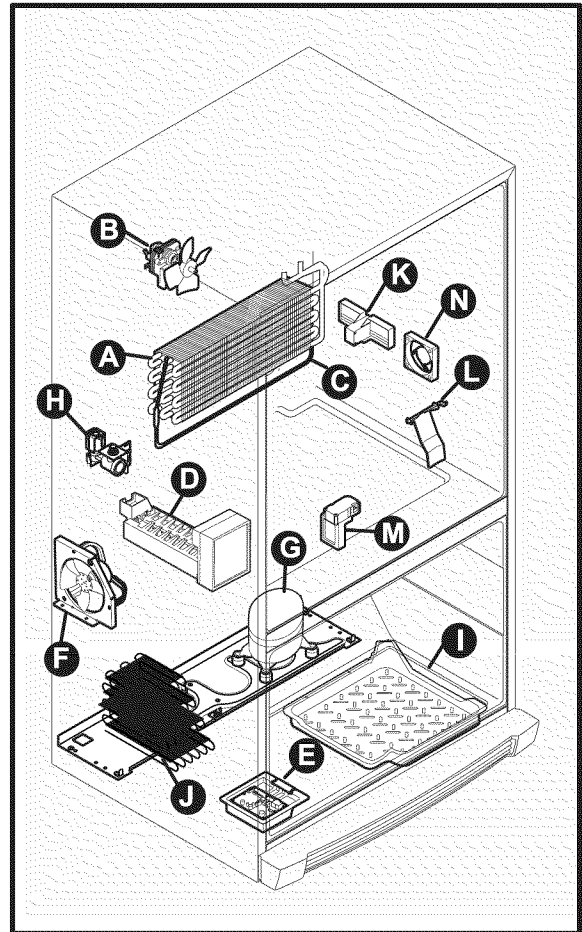



Your refrigerator is equipped with separate water and air filtering systems. The water filter system filters all the water used to produce ice. The air filter removes odors and impurities from the refrigerator compartment.

## NOTE

The control panel includes controls to monitor the status of your water and air filters. See the Controls section for more information.

## About your advanced water filter



The **PureAdvantage™** NGFC-2000 filter system is tested and certified by NSF International to NSF/ANSI Standards 42 and 53 for the reduction of claims specified on the performance data sheet.

Do not use with water that is microbiologically unsafe or of unknown quality without adequate disinfection before or after the system. Systems certified for cyst reduction may be used on disinfected waters that may contain filterable cysts.

- Rated Capacity - 240 gallons
- Rated service flow - .5 gallons per minute
- Maximum Rated Pressure - 100 pounds per square inch
- Recommended Minimum Operating Pressure: 30 pounds per square inch
- Operating Temp.: Min. 33°F, Max. 100°F

## Water filter

The water filter is located at the lower left side of the fresh food compartment.

## Replacing your **PureAdvantage™** water filter

In general, you should change the water filter every six (6) months to ensure the highest possible water quality. The **Water Filter Status** light on the Touch Panel prompts you to replace the filter after the 6 month time period has elapsed. The water filter status light on this model is not performance tested or certified by NSF.

If your refrigerator has not been used for a period of time (during moving for example), change the filter before reinstalling the refrigerator.

It is not necessary to turn the water supply off to change the filter. Be ready to wipe up any small amounts of water released during the filter replacement.

- 1 Push the filter release button above the cartridge to disconnect it.

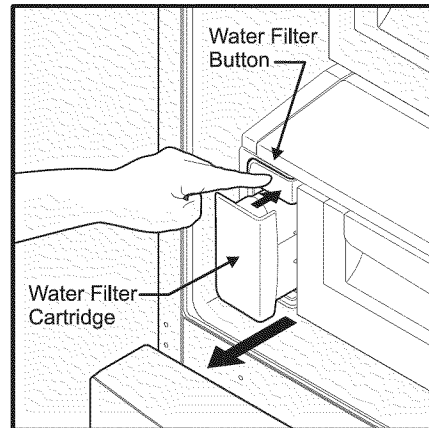

**Push Water Filter Button**

- 2 Slide the old water filter cartridge straight out of the housing and discard it.
- 3 Unpack the new filter cartridge and remove the two (2) protective caps covering the inlet and exit of the filter. Slide the filter gently into the housing until it stops against the snap-in connector at the back of the housing.

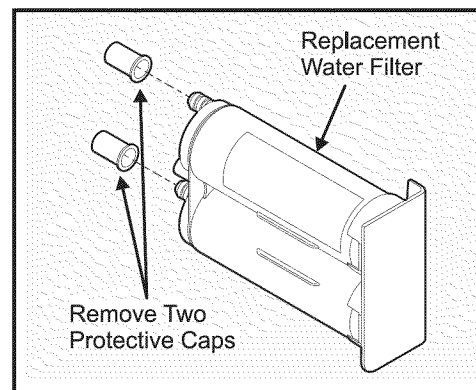

# 26 Changing the Water and Air Filters

- 4 Push firmly until the cartridge snaps into place (you should hear two clicks). When fully engaged, the front of the filter cartridge should be flush with the filter release button.

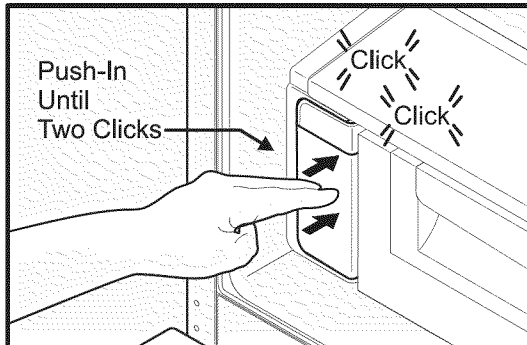

Reinstall Water Filter

- 5 Press and hold the **Filter Status** button on the control panel for three (3) seconds. When the display changes from **Replace** to **Good**, the status has been reset.
- 6 After replacing the water filter and in order for the ice maker to work properly, it is necessary to clear air from water filter tubing. Once ice maker begins making ice, allow the bucket to fill completely, then discard the first TWO (2) FULL buckets of ice. It will take at least two (2) days to completely fill the bucket on regular ice making mode or 1 1/2 days on fast ice mode.

## Air filter

The air filter is located under the utility bin.

### Replacing your *PureAdvantage*<sup>™</sup> air filter

To ensure optimal filtering of refrigerator odors, you should change the air filter every six (6) months (the filter status light on the Touch Panel prompts you to replace the filter after six (6) months).

- 1 Open the air filter door.
- 2 Remove the old filter and discard it.
- 3 Unpack the new filter and slide it into the housing.
- 4 To close the air filter door, push the top and bottom to lock the door closed.
- 5 Press and hold the **Air Filter Reset** button on the control panel for three (3) seconds. When the display changes from "**Replace**" to "**Good**," the status has been reset.
- 6 The **Air Filter Reset** will turn itself off after a few seconds.

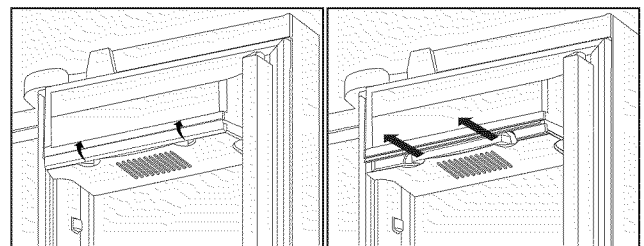

## Ordering replacement filters

Order new filters by calling 877-808-4195, online at [www.electroluxappliances.com](http://www.electroluxappliances.com), or through the dealer where you bought your refrigerator. You may want to consider ordering extra filters when you first install your refrigerator.

Water Filter FC-300 *PureAdvantage*<sup>™</sup>  
Replacement Cartridge #EWFO1

Air Filter Replacement cartridge, part  
#EAFCBF

## Protecting your investment

Keeping your refrigerator clean maintains its appearance and prevents odor build-up. Wipe up any spills immediately and clean the freezer and fresh food compartments at least twice a year.

### NOTE

Do not use abrasive cleaners such as window sprays, scouring cleansers, flammable fluids, cleaning waxes, concentrated detergents, bleaches, or cleansers containing petroleum products on plastic parts, interior doors, gaskets, or cabinet liners. Do not use paper towels, scouring pads, or other abrasive cleaning materials.

- Never use metallic scouring pads, brushes, abrasive cleaners, or strong alkaline solutions on any surface.
- Never use CHLORIDE or cleaners with bleach to clean stainless steel.
- Do not wash any removable parts in a dishwasher.
- Always unplug the electrical power cord from the wall outlet before cleaning.

### NOTE

If you set your temperature controls to turn off cooling, power to lights and other electrical components will continue until you unplug the power cord from the wall outlet.

- Remove adhesive labels by hand. Do not use razor blades or other sharp instruments which can scratch the appliance surface.
- Do not remove the serial plate. Removal of your serial plate voids your warranty.
- Before moving your refrigerator, raise the anti-tip brackets so the rollers will work correctly. This will prevent the floor from being damaged.

### CAUTION

- **Pull the refrigerator straight out to move it. Shifting it from side to side may damage flooring. Be careful not to move the refrigerator beyond the plumbing connections.**
- **Damp objects stick to cold metal surfaces. Do not touch refrigerated surfaces with wet or damp hands.**

### IMPORTANT

If you store or move your refrigerator in freezing temperatures, be sure to completely drain the water supply system. Failure to do so could result in water leaks when the refrigerator is put back into service. Contact a service representative to perform this operation.

Refer to the guide on the next page for details on caring and cleaning specific areas of your refrigerator.

# 28 Care and Cleaning

## Care and cleaning tips

Part	Cleaning Agents	Tips and Precautions
Interior & Door Liners	<ul style="list-style-type: none"><li>• Soap and water</li><li>• Baking soda and water</li></ul>	<ul style="list-style-type: none"><li>• Use 2 (2) tablespoons of baking soda in 1 (1) quart of warm water.</li><li>• Be sure to wring excess water out of sponge or cloth before cleaning around controls, light bulb or any electrical part.</li></ul>
Door Gaskets	<ul style="list-style-type: none"><li>• Soap and water</li></ul>	<ul style="list-style-type: none"><li>• Wipe gaskets with a clean soft cloth.</li></ul>
Drawers & Bins	<ul style="list-style-type: none"><li>• Soap and water</li></ul>	<ul style="list-style-type: none"><li>• Use a soft cloth to clean drawer runners and tracks.</li><li>• Do not wash any removable items (bins, drawers, etc.) in dishwasher.</li></ul>
Glass Shelves	<ul style="list-style-type: none"><li>• Soap and water</li><li>• Glass cleaner</li><li>• Mild liquid sprays</li></ul>	<ul style="list-style-type: none"><li>• Allow glass to warm to room temperature before immersing in warm water.</li></ul>
Toe Grille	<ul style="list-style-type: none"><li>• Soap and water</li><li>• Mild liquid sprays</li><li>• Vacuum</li></ul>	<ul style="list-style-type: none"><li>• Remove toe grille (see Installation Instructions).</li><li>• Vacuum both sides and wipe with sudsy cloth or sponge. Rinse and dry.</li></ul>
Exterior & Handles	<ul style="list-style-type: none"><li>• Soap and water</li><li>• Non abrasive glass cleaner</li></ul>	<ul style="list-style-type: none"><li>• Do not use commercial household cleaners containing ammonia, bleach or alcohol to clean handles.</li><li>• Use a soft cloth to clean smooth handles.</li><li>• Do not use a dry cloth to clean smooth doors.</li></ul>
Exterior & Handles (Stainless Steel Models Only)	<ul style="list-style-type: none"><li>• Soap and water</li><li>• Stainless steel cleaners</li></ul>	<ul style="list-style-type: none"><li>• <b>Never use CHLORIDE or cleaners with bleach to clean stainless steel.</b></li><li>• Clean stainless steel front and handles with non-abrasive soapy water and a dishcloth. Rinse with clean water and a soft cloth.</li><li>• Use a non-abrasive stainless steel cleaner. These cleaners can be purchased at most home improvement or major department stores. Always follow manufacturer's instruction. Do not use household cleaners containing ammonia or bleach.</li><li>• NOTE: Always clean, wipe and dry with grain to prevent scratching.</li><li>• Wash the rest of the cabinet with warm water and mild liquid detergent. Rinse well and wipe dry with a clean soft cloth.</li></ul>

## Vacation and moving tips

Occasion	Tips
Short Vacations	<ul style="list-style-type: none"><li>• Leave refrigerator operating during vacations of three (3) weeks or less.</li><li>• Use all perishable items from refrigerator compartment.</li><li>• Turn automatic ice maker off and empty ice bucket, even if you will only be gone a few days.</li></ul>
Long Vacations	<ul style="list-style-type: none"><li>• Remove all food and ice if you will be gone one (1) month or more.</li><li>• Turn the cooling system off (see <b>Controls</b> section for location of <b>On/Off</b> button) and disconnect power cord.</li><li>• Turn water supply valve to closed position.</li><li>• Clean interior thoroughly.</li><li>• Leave doors open to prevent odors and mold build-up. Block doors open if necessary.</li></ul>
Moving	<ul style="list-style-type: none"><li>• Remove all food and ice.</li><li>• If using a handcart, load from the side.</li><li>• Adjust rollers all the way up to protect them during sliding or moving.</li><li>• Pad cabinet to avoid scratching surface.</li></ul>

## Replacing LED Lights *(select models)*

Both the freezer and fresh food compartments of your refrigerator include LED lights. Always use Electrolux parts for replacement.

### To replace LED Lights:

- 1 Unplug your refrigerator's power cord.
- 2 Remove light cover by pushing up and out.
- 3 Hold the LED cover with one hand and pull the connector with the other hand while pressing the connector latch.
- 4 Replace LED light and snap in place assuring the light is facing in toward the unit (inside fresh food and freezer) or facing outward on bottom of fresh food doors.

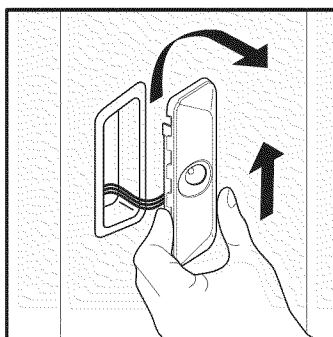

LED Light Removal

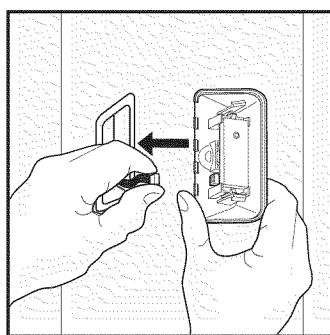

LED Light Harness Removal



### NOTE

LED lights are in series so if one is bad or unplugged, several lights may not light up.

## Ordering Replacement LED Lights

Order new LEDs by calling 877-808-4195, online at [www.electroluxappliances.com](http://www.electroluxappliances.com), or through the dealer where you bought the refrigerator. Here is the product number to request when ordering:

**LED Light, Part #241891102**

**Incandescent Lights (40-watt bulb),  
Part #5305514148**

# 30 Common Solutions for Concerns

## Before you call...

If you experience a concern with your refrigerator or notice a product behavior or condition that you do not understand, you can usually avoid a call to your service representative by referring to this section for an answer. Beginning with the following table, this information includes concerns, potential causes, and common solutions.

<b>Automatic Ice Maker</b>		
<b>Concern</b>	<b>Potential Cause</b>	<b>Common Solution</b>
Ice maker is not making any ice.	<ul style="list-style-type: none"> <li>Ice maker is turned off.</li> <li>Refrigerator is not connected to water line or water valve is not open.</li> <li>The water supply line is kinked.</li> <li>The water filter is not seated properly.</li> <li>The water filter may be clogged with foreign material.</li> <li>Saddle valve on cold water pipe is clogged or restricted by foreign material.</li> </ul>	<ul style="list-style-type: none"> <li>Lower the wire signal arm.</li> <li>Connect the unit to the household water supply and ensure the supply valve is open.</li> <li>Ensure that the supply line does not kink when the refrigerator is pushed into place against the wall.</li> <li>Remove and re-install the water filter. Be sure to push the filter firmly so that you hear it lock solidly into position.</li> <li>If water dispenses slowly or not at all, or if the filter is six (6) months old or older, it should be replaced.</li> <li>Turn off household water line valve. Remove valve. Ensure that valve is not a self-piercing saddle valve. Clean valve. Replace valve if necessary.</li> </ul>
Ice maker is not making enough ice.	<ul style="list-style-type: none"> <li>Ice maker is producing less ice than you expect.</li> <li>The water filter may be clogged with foreign material.</li> <li>The water supply line is kinked.</li> <li>Saddle valve on cold water pipe is clogged or restricted by foreign material.</li> </ul>	<ul style="list-style-type: none"> <li>The freezer ice maker will produce approximately 2.5 pounds of ice every 24 hours depending on usage conditions.</li> <li>If the filter is six (6) months old or older, it should be replaced.</li> <li>Ensure that the supply line does not kink when the refrigerator is pushed into place against the wall.</li> <li>Turn off household water line valve. Remove valve. Ensure that valve is not a self-piercing saddle valve. Clean valve. Replace valve if necessary.</li> </ul>
Ice maker will not stop making ice.	<ul style="list-style-type: none"> <li>Ice maker wire signal arm is being held down by some package in the freezer that has fallen against the ice maker.</li> </ul>	<ul style="list-style-type: none"> <li>Move the item and release wire signal arm. Remove any ice cubes that may have frozen together over the wire signal arm.</li> </ul>
Ice cubes are freezing together.	<ul style="list-style-type: none"> <li>Ice cubes are not being used frequently enough.</li> <li>Ice cubes are hollow (shells of ice with water inside). The hollow cubes break open in the bin and leak their water onto existing ice, which causes it to freeze together.</li> </ul>	<ul style="list-style-type: none"> <li>Remove ice container and discard ice. The ice maker will produce fresh supply. Ice should be used at least twice weekly to keep the cubes separated.</li> <li>This generally occurs when the ice maker does not get enough water. This is usually the result of a clogged water filter. Replace the water filter.</li> </ul>
<b>Light Is Not On</b>		
<b>Concern</b>	<b>Potential Cause</b>	<b>Common Solution</b>
Light is not on.	<ul style="list-style-type: none"> <li>LED light is damaged.</li> <li>No electric current is reaching refrigerator.</li> <li>Control system has disabled lights because one or both doors were left open too long.</li> </ul>	<ul style="list-style-type: none"> <li>See Replacing LED lights in Care and Cleaning section.</li> <li>See "Concern" section, "Refrigerator Operations".</li> <li>Close and reopen door(s) to enable lights.</li> </ul>
<b>Odors In Refrigerator</b>		
<b>Concern</b>	<b>Potential Cause</b>	<b>Common Solution</b>
Interior is dirty. Odors	<ul style="list-style-type: none"> <li>Interior needs to be cleaned.</li> <li>Food with strong odors is stored in refrigerator.</li> </ul>	<ul style="list-style-type: none"> <li>See Care &amp; Cleaning Tips.</li> <li>Cover food tightly. Air filter may need to be changed more frequently if foods with strong odors are routinely stored in refrigerator.</li> </ul>

<b>Opening/Closing Of Doors/Drawers</b>		
<b>Concern</b>	<b>Potential Cause</b>	<b>Common Solution</b>
Door(s) will not close.	<ul style="list-style-type: none"> <li>• Refrigerator is not level. It rocks on the floor when moved slightly.</li> <li>• An object has fallen from the baskets blocking the door from closing.</li> </ul>	<ul style="list-style-type: none"> <li>• Ensure floor is level and solid, and can adequately support the refrigerator. Contact a carpenter to correct a sagging or sloping floor.</li> <li>• Check for ice or food items blocking drawer.</li> </ul>
Drawers are difficult to move.	<ul style="list-style-type: none"> <li>• Food is touching shelf on top of drawer.</li> <li>• Drawer is overloaded.</li> </ul>	<ul style="list-style-type: none"> <li>• Keep less food in drawer.</li> <li>• Remove or redistribute food.</li> </ul>
<b>Refrigerator Operations</b>		
<b>Concern</b>	<b>Potential Cause</b>	<b>Common Solution</b>
Compressor does not run.	<ul style="list-style-type: none"> <li>• Cooling system is turned Off.</li> <li>• Refrigerator is in defrost cycle.</li> <li>• Plug at wall outlet is disconnected.</li> <li>• House fuse is blown or a tripped circuit breaker.</li> <li>• Power outage.</li> <li>• Electronic control system keeps the refrigerator at a constant temperature.</li> </ul>	<ul style="list-style-type: none"> <li>• Turn cooling system On. See Controls Section for location of cooling system <b>On/Off</b> button.</li> <li>• This is normal for a fully automatic defrost refrigerator. The defrost cycle occurs periodically, lasting about 30 minutes.</li> <li>• Ensure plug is tightly pushed into outlet.</li> <li>• Check/replace fuse with a 15 amp time-delay fuse. Reset circuit breaker.</li> <li>• Check house lights. Call local Electric Company.</li> <li>• This is normal. Refrigerator goes on and off to keep temperature constant.</li> </ul>
Refrigerator runs too much or too long.	<ul style="list-style-type: none"> <li>• Room or outside weather is hot.</li> <li>• Refrigerator has recently been disconnected for a period of time.</li> <li>• Automatic ice maker is operating.</li> <li>• Doors are opened too frequently or too long.</li> <li>• Refrigerator/freezer door may be slightly open.</li> <li>• Freezer control is set too cold (control found on side of left hand door).</li> <li>• Fresh food/freezer gasket is dirty, worn, cracked, or poorly fitted.</li> <li>• This model is provided with a high-efficiency, variable-speed compressor.</li> </ul>	<ul style="list-style-type: none"> <li>• It's normal for the refrigerator to work longer under these conditions.</li> <li>• It takes 8-12 hours for the refrigerator to cool down completely.</li> <li>• Ice maker operation causes refrigerator to run slightly more.</li> <li>• Warm air entering the refrigerator causes it to run more. Open doors less often.</li> <li>• Ensure refrigerator is level. Keep food and containers from blocking door. See Problem section, Opening/Closing of Doors/ Drawers.</li> <li>• Set freezer control to warmer setting until refrigerator temperature is satisfactory. Allow 24 hours for temperature to stabilize.</li> <li>• Clean or change gasket. Leaks in door seal will cause refrigerator to run longer in order to maintain desired temperatures.</li> <li>• It is normal for the compressor to run for long periods of time.</li> </ul>
Digital temperature displays are flashing.	<ul style="list-style-type: none"> <li>• Electronic control system has detected a performance problem.</li> </ul>	<ul style="list-style-type: none"> <li>• Call your Electrolux service representative, who can interpret any messages or number codes flashing on the digital displays.</li> </ul>

# 32 Common Solutions for Concerns

## *Temperatures Are Too Cold*

<b>Concern</b>	<b>Potential Cause</b>	<b>Common Solution</b>
Freezer temperature too cold. Refrigerator temperature is satisfactory.	<ul style="list-style-type: none"> <li>• Fast Freeze function is activated.</li> <li>• Freezer control is set too cold.</li> <li>• Ice maker is on.</li> <li>• Fast Ice function is activated.</li> </ul>	<ul style="list-style-type: none"> <li>• Deactivate Fast Freeze function.</li> <li>• Set freezer control to a warmer setting. Allow 24 hours for temperature to stabilize.</li> <li>• It is normal for the freezer compartment to over cool while automatic ice maker is on.</li> <li>• Deactivate Fast Ice function.</li> </ul>
Refrigerator temperature too cold. Freezer temperature is satisfactory.	<ul style="list-style-type: none"> <li>• Refrigerator control is set too cold.</li> </ul>	<ul style="list-style-type: none"> <li>• Set refrigerator control to a warmer setting. Allow 24 hours for temperature to stabilize.</li> </ul>
Food stored in drawers freezes.	<ul style="list-style-type: none"> <li>• Refrigerator control is set too cold.</li> </ul>	<ul style="list-style-type: none"> <li>• See solution above.</li> </ul>
Food stored in Meat Keeper freezes (select models).	<ul style="list-style-type: none"> <li>• Meat Keeper temperature control is set too cold.</li> </ul>	<ul style="list-style-type: none"> <li>• Adjust Meat Keeper temperature control to a warmer setting. Meat should be stored at a temperature just below the freezing point for maximum fresh storage time. It is normal for ice crystals to form due to the moisture content of meat.</li> </ul>

## *Temperatures Are Too Warm*

<b>Concern</b>	<b>Potential Cause</b>	<b>Common Solution</b>
Freezer/Refrigerator temperature is too warm.	<ul style="list-style-type: none"> <li>• Doors are opened too frequently or too long.</li> <li>• Door is slightly open.</li> </ul>	<ul style="list-style-type: none"> <li>• Warm air enters the refrigerator whenever the door is opened. Open the door less often.</li> <li>• See Problem section, Opening/Closing of Doors/Drawers.</li> </ul>
Freezer temperature is too warm. Refrigerator temperature is satisfactory.	<ul style="list-style-type: none"> <li>• Freezer control is set too warm.</li> </ul>	<ul style="list-style-type: none"> <li>• Set freezer control to a colder setting. Allow 24 hours for temperature to stabilize.</li> </ul>
Refrigerator temperature is too warm. Freezer temperature is satisfactory.	<ul style="list-style-type: none"> <li>• Refrigerator control is set too warm.</li> </ul>	<ul style="list-style-type: none"> <li>• Set refrigerator control to a colder setting. Allow 24 hours for temperature to stabilize.</li> </ul>
Temperature in the Cool Zone™ or Perfect Temp™ Drawer is too warm (select models).	<ul style="list-style-type: none"> <li>• Temperature control is set too warm.</li> </ul>	<ul style="list-style-type: none"> <li>• Adjust temperature control to a colder setting.</li> </ul>



<b>Water/Moisture/Frost Inside Refrigerator</b>		
<b>Concern</b>	<b>Potential Cause</b>	<b>Common Solution</b>
Moisture collects on inside of refrigerator walls.	<ul style="list-style-type: none"> <li>• Weather is hot and humid.</li> <li>• Door is slightly open.</li> <li>• Door is opened too often or too long.</li> <li>• Open containers.</li> </ul>	<ul style="list-style-type: none"> <li>• The rate of frost buildup and internal sweating increases.</li> <li>• See Problem section, Opening/Closing of Doors/Drawers.</li> <li>• Open door less often to allow internal temperature to stabilize.</li> <li>• Keep containers covered.</li> </ul>
Water collects on bottom side of drawer cover.	<ul style="list-style-type: none"> <li>• Vegetables contain and give off moisture.</li> </ul>	<ul style="list-style-type: none"> <li>• Moisture on the bottom side of the cover is not unusual.</li> <li>• Move humidity control (select models) to lower setting.</li> </ul>
Moisture collects in bottom of drawer.	<ul style="list-style-type: none"> <li>• Washed vegetables and fruit drain while in the drawer.</li> <li>• Fruits and vegetables are kept past their prime</li> </ul>	<ul style="list-style-type: none"> <li>• Dry items before putting them in the drawer. Water collecting in bottom of drawer is normal.</li> <li>• Routinely clean out old fruits and vegetables especially if they begin to break down.</li> </ul>
Moisture collects on outside of refrigerator or between doors.	<ul style="list-style-type: none"> <li>• Weather is humid.</li> <li>• Door is slightly open, causing cold air from inside refrigerator to meet warm air from outside.</li> </ul>	<ul style="list-style-type: none"> <li>• This is normal in humid weather. Press eco friendly icon to reduce exterior moisture on the cabinet between the doors. When humidity is lower, the moisture should disappear and the eco friendly icon can be pressed again to turn it off.</li> <li>• See Problem section, Opening/Closing of Doors/Drawers.</li> </ul>

## Major Appliance Warranty Information

Your appliance is covered by a one year limited warranty. For one year from your original date of purchase, Electrolux will repair or replace any parts of this appliance that prove to be defective in materials or workmanship when such appliance is installed, used, and maintained in accordance with the provided instructions. In addition, the cabinet liner and sealed refrigeration system (compressor, condenser, evaporator, dryer or tubing) of your appliance is covered by a two through five year limited warranty. During the 2nd through 5th years from your original date of purchase, Electrolux will repair or replace any parts in the cabinet liner and sealed refrigeration system which prove to be defective in materials or workmanship when such appliance is installed, used, and maintained in accordance with the provided instructions.

### Exclusions

This warranty does not cover the following:

1. Products with original serial numbers that have been removed, altered or cannot be readily determined.
2. Product that has been transferred from its original owner to another party or removed outside the USA or Canada.
3. Rust on the interior or exterior of the unit.
4. Products purchased "as-is" are not covered by this warranty.
5. Food loss due to any refrigerator or freezer failures.
6. Products used in a commercial setting.
7. Service calls which do not involve malfunction or defects in materials or workmanship, or for appliances not in ordinary household use or used other than in accordance with the provided instructions.
8. Service calls to correct the installation of your appliance or to instruct you how to use your appliance.
9. Expenses for making the appliance accessible for servicing, such as removal of trim, cupboards, shelves, etc., which are not a part of the appliance when it is shipped from the factory.
10. Service calls to repair or replace appliance light bulbs, air filters, water filters, other consumables, or knobs, handles, or other cosmetic parts.
11. Pickup and delivery costs; your appliance is designed to be repaired in the home.
12. Surcharges including, but not limited to, any after hour, weekend, or holiday service calls, tolls, ferry trip charges, or mileage expense for service calls to remote areas, including the state of Alaska.
13. Damages to the finish of appliance or home incurred during transportation or installation, including but not limited to floors, cabinets, walls, etc.
14. Damages caused by: services performed by unauthorized service companies; use of parts other than genuine Electrolux parts or parts obtained from persons other than authorized service companies; or external causes such as abuse, misuse, inadequate power supply, accidents, fires, or acts of God.

### DISCLAIMER OF IMPLIED WARRANTIES; LIMITATION OF REMEDIES

CUSTOMER'S SOLE AND EXCLUSIVE REMEDY UNDER THIS LIMITED WARRANTY SHALL BE REPAIR OR REPLACEMENT AS PROVIDED HEREIN. **CLAIMS BASED ON IMPLIED WARRANTIES, INCLUDING WARRANTIES OF MERCHANTABILITY OR FITNESS FOR A PARTICULAR PURPOSE, ARE LIMITED TO ONE YEAR OR THE SHORTEST PERIOD ALLOWED BY LAW, BUT NOT LESS THAN ONE YEAR.** ELECTROLUX SHALL NOT BE LIABLE FOR CONSEQUENTIAL OR INCIDENTAL DAMAGES SUCH AS PROPERTY DAMAGE AND INCIDENTAL EXPENSES RESULTING FROM ANY BREACH OF THIS WRITTEN LIMITED WARRANTY OR ANY IMPLIED WARRANTY. SOME STATES AND PROVINCES DO NOT ALLOW THE EXCLUSION OR LIMITATION OF INCIDENTAL OR CONSEQUENTIAL DAMAGES, OR LIMITATIONS ON THE DURATION OF IMPLIED WARRANTIES, SO THESE LIMITATIONS OR EXCLUSIONS MAY NOT APPLY TO YOU. THIS WRITTEN WARRANTY GIVES YOU SPECIFIC LEGAL RIGHTS. YOU MAY ALSO HAVE OTHER RIGHTS THAT VARY FROM STATE TO STATE.

### If You Need Service

Keep your receipt, delivery slip, or some other appropriate payment record to establish the warranty period should service be required. If service is performed, it is in your best interest to obtain and keep all receipts. Service under this warranty must be obtained by contacting Electrolux at the addresses or phone numbers below.

This warranty only applies in the USA, Puerto Rico and Canada. In the USA and Puerto Rico, your appliance is warranted by Electrolux Major Appliances North America, a division of Electrolux Home Products, Inc. In Canada, your appliance is warranted by Electrolux Canada Corp. Electrolux authorizes no person to change or add to any obligations under this warranty. Obligations for service and parts under this warranty must be performed by Electrolux or an authorized service company. Product features or specifications as described or illustrated are subject to change without notice.

#### USA

1-877-435-3287

Electrolux Major Appliances North America  
10200 David Taylor Drive  
Charlotte, NC 28262

#### Canada

1-800-265-8352

Electrolux Canada Corp.  
5855 Terry Fox Way  
Mississauga, Ontario, Canada L5V 3E4