

Installation Instructions

for Topload Washers

Inside.....

Washer Dimensions.....	2
Before You Start.....	2
Installation.....	3
Installer Checklist.....	Back Cover

Date Purchased _____
Model Number _____
Serial Number _____

Para bajar una copia de estas instrucciones en español, visite www.speedqueen.com.

Keep these instructions for future reference.

(If this machine changes ownership, this manual must accompany machine.)

Washer Dimensions

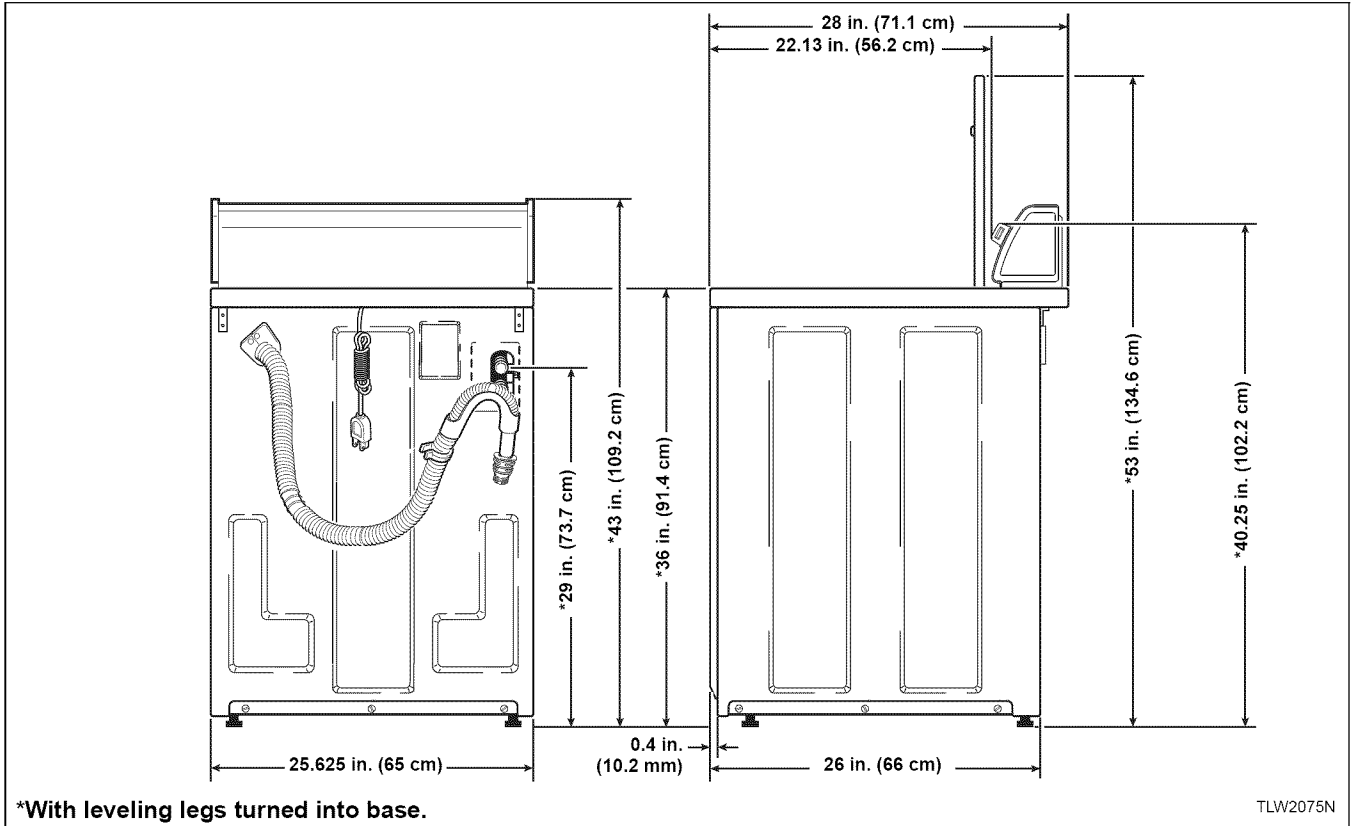

Figure 1

Before You Start

Supplies

For most installations, the basic supplies you will need are:

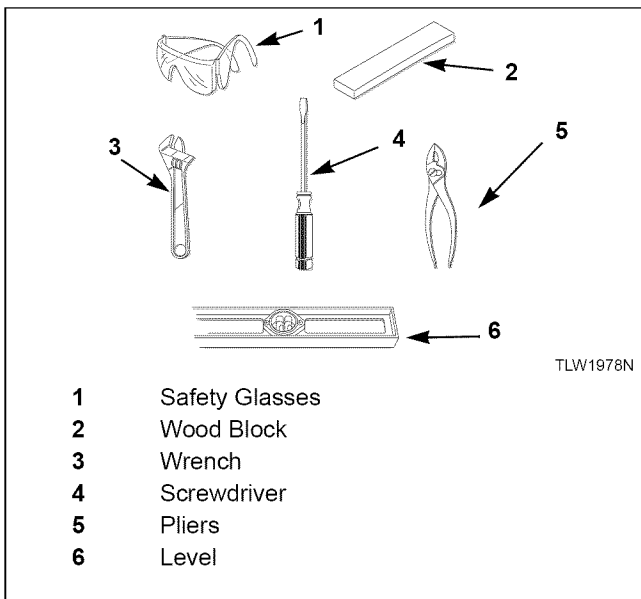

Figure 2

Parts Included

An accessories bag has been shipped inside your washer. It includes:

- Two fill hoses with washers and filter screens. Refer to step 3 of *Installation*.
- Four rubber feet. Refer to step 5 of *Installation*.
- Beaded strap. Refer to step 4 of *Installation*.
- Installation Instructions.
- User's Guide.
- Warranty Bond.

NOTE: If the washer is delivered on a cold day (below freezing), or is stored in an unheated room or area during the cold months, do not attempt to operate it until the washer has had a chance to warm up.

NOTE: Install dryer before washer. This allows room for attaching exhaust duct.

Installation

Step 1: Remove the Shipping Brace and Shipping Plug

Remove the shipping brace from under the lid.

The shipping plug will be released from the base of the washer when removing the cardboard base from the washer. Refer to *Figure 3*.

NOTE: Do not tilt washer to front or sides when moving.

Save the shipping brace and plug. They must be reinstalled whenever washer is moved or transported to a new location. This will prevent damage to the washer. Refer to the User's Guide for instructions on reinstalling the shipping materials.

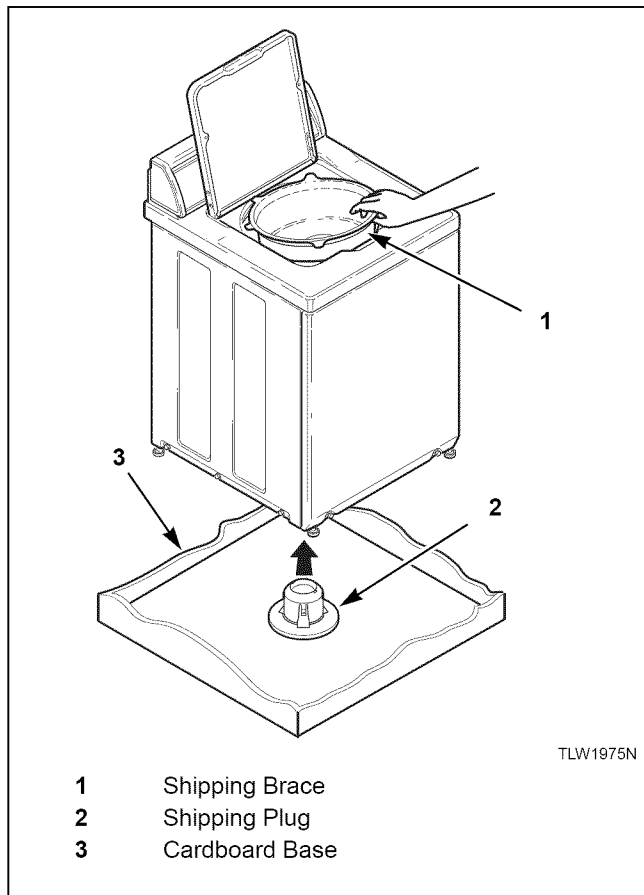

Figure 3

Step 2: Wipe Out Inside of Washtub

Prior to first wash, use an all purpose cleaner, or a detergent and water solution, and a damp cloth to remove shipping dust from inside of washtub.

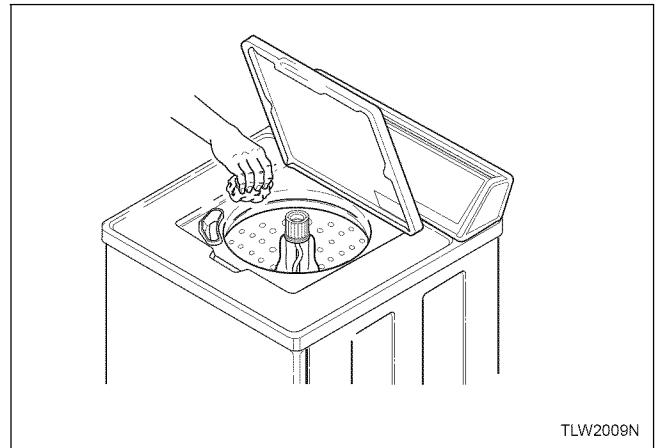



Figure 4

Step 3: Connect Fill Hoses

	WARNING
<p>Under certain conditions, hydrogen gas may be produced in a hot water system that has not been used for two weeks or more. HYDROGEN GAS IS EXPLOSIVE. If the hot water system has not been used for such a period and before using the washer, turn on all hot water faucets and let the water flow from each for several minutes. This will release any accumulated hydrogen gas. The gas is flammable. Do not smoke or use an open flame during this time.</p>	
<small>W029</small>	

Mixing Valve Flow Rates (Gallons per Minute)			
	Hot	Cold	Warm (40% Hot)
35 psi	2.4	4.5	7.15
55 psi	3.5	6.2	9.2

Table 1

Water Supply

Water supply faucets must fit standard 3/4 inch (19.1 mm) female garden hose couplings. **DO NOT USE SLIP-ON OR CLAMP-ON CONNECTIONS.**

Water supply faucets should be readily accessible to permit turning them off when washer is not being used.

Recommended cold water temperature is 50° to 75° Fahrenheit (10° to 24° Celsius). Recommended maximum hot water temperature is 125° Fahrenheit (51° Celsius). Warm water is a mixture of hot and cold water. Warm water temperature is dependent upon water temperature and pressure of both the hot and cold water supply lines.

	WARNING
<p>To prevent personal injury, avoid contact with inlet water temperatures higher than 125° Fahrenheit (51° Celsius) and hot surfaces.</p>	
<small>W748</small>	

Water pressure must be a minimum of 20 to a maximum of 120 pounds per square inch (138 to 827 kPa) static pressure measured at the faucet.

NOTE: Water pressure under 20 pounds per square inch (138 kPa) will cause an extended fill time in the washer.

Turn on the water faucets and flush the lines for approximately two minutes to remove any foreign material that could clog the screens in the water mixing valve.

NOTE: When installing in newly constructed or renovated buildings, it is very important to flush the lines since build-up may have occurred during construction.

Connecting Hoses

Remove the two plain rubber washers and two filter screens from the accessories bag. Install them into each end of the fill hoses as shown in *Figure 5*. The screen must be facing outward.

Screw hose couplings with the filter screens onto the water faucets until they are finger-tight. Then, using a pliers, screw approximately 1/4 turn. Use the red color-coded hose for the hot water connection and the blue color-coded hose for the cold water connection.

Screw hose couplings from other end of hoses onto the water mixing valve until they are finger-tight. Then, using a pliers, screw approximately 1/4 turn. Refer to *Figure 6*. Make sure the red color-coded hose from the hot water faucet goes to the water mixing valve marked “H” and the blue color-coded hose from the cold faucet goes to the valve marked “C”.

IMPORTANT: Do not cross thread or overtighten couplings. This will cause them to leak.

Turn water on and check for leaks. If leaks are found, turn off the water, unscrew hoses and reinstall them until there are no leaks.

IMPORTANT: Turn off water supply whenever there will be an extended period of non-use.

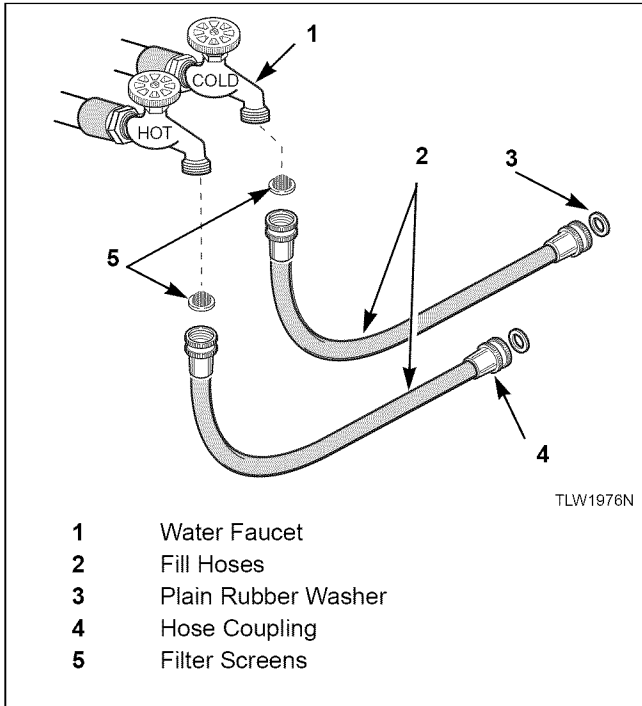

Figure 5

IMPORTANT: Hoses and other natural rubber parts deteriorate after extended use. Hoses may develop cracks, blisters or material wear from the temperature and constant high pressure they are subject to.

All hoses should be checked on a monthly basis for any visible signs of deterioration. Any hose showing the signs of deterioration listed above should be replaced immediately. All hoses should be replaced every five years.

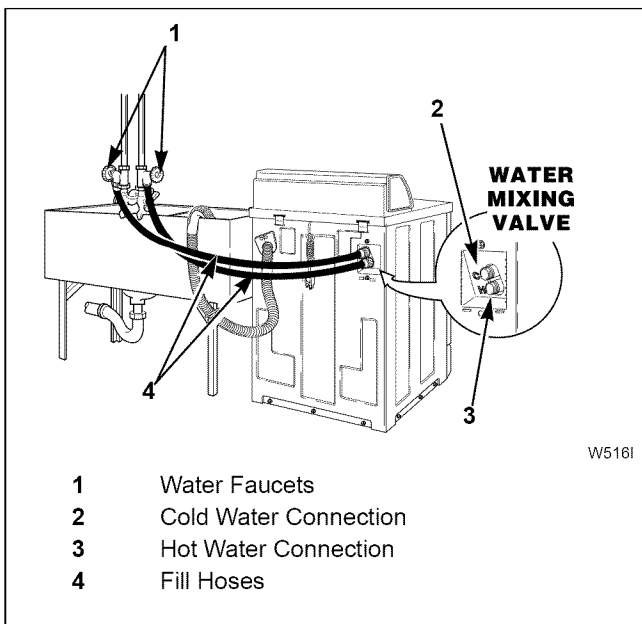

Figure 6

Step 4: Connect Drain Hose to Drain Receptacle

Remove the drain hose from its shipping position on the rear of the washer by unhooking the hose from the retainer clamp.

Install the drain hose into the drain receptacle (standpipe, wall or laundry tub) following the instructions below.

IMPORTANT: Drain receptacle must be capable of handling a minimum of 1-1/4 inch (32 cm) outside diameter drain hose.

Standpipe Installation:

Place the adapter into the standpipe.

The recommended height for the standpipe is 36 inches (91.44 cm). Standpipes higher than 4 feet (122 cm) are not recommended.

Remove the beaded strap from accessories bag and place around standpipe and drain hose, approximately 12 inches (30 cm) down from the top of pipe and tighten strap to hold hose to standpipe. Refer to *Figure 7*. This will prevent the drain hose from dislodging from drain receptacle during use.

IMPORTANT: To prevent siphoning, do not place any ribbed portion of the drain hose into the standpipe.

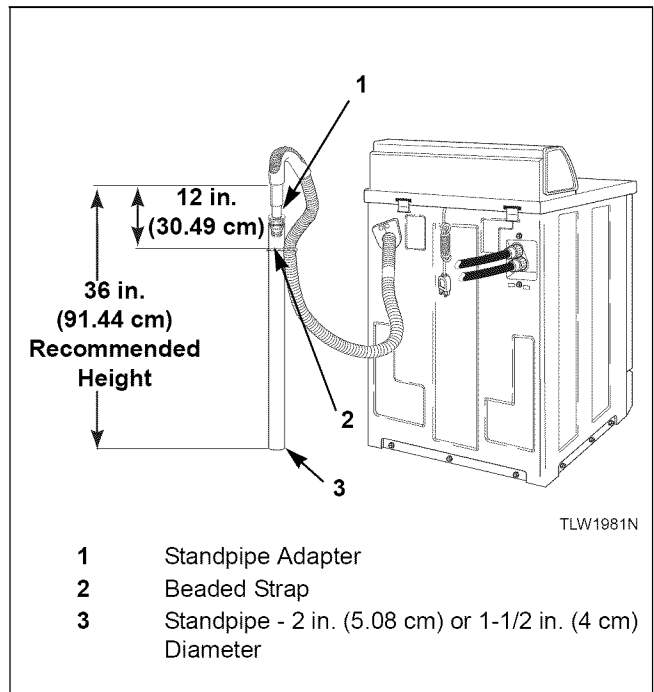

Figure 7

If standpipe is lower than 36 inches (91.44 cm), you must install No. 562P3 Siphon Break Kit. Refer to *Figure 8*. This kit is available (as optional equipment at extra cost) through an authorized dealer or parts distributor. Installation instructions are supplied with the kit.

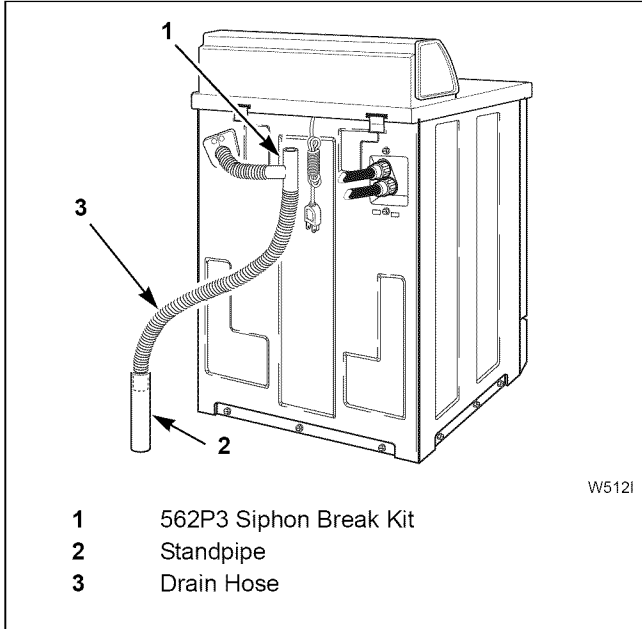

Figure 8

Laundry Tub Installation:

For this type of installation, the drain hose **MUST** be secured to the stationary tub to prevent hose from dislodging during use. Refer to *Figure 10*. Use the beaded strap (supplied in accessories bag) to secure hose.

We recommend leaving the standpipe adapter on the drain hose for this type of installation.

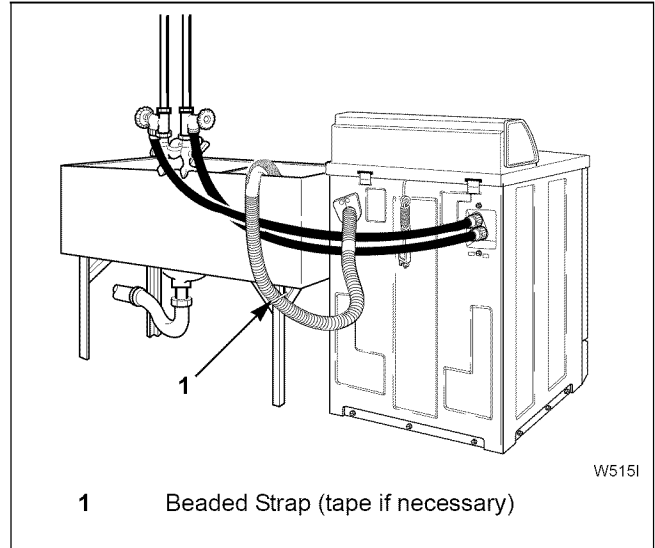

Figure 10

Wall Installation:

For installations of this type, the drain hose **MUST** be secured to one of the fill hoses using the beaded strap from accessories bag. Refer to *Figure 9*.

NOTE: End of drain hose must be below height of cabinet top.

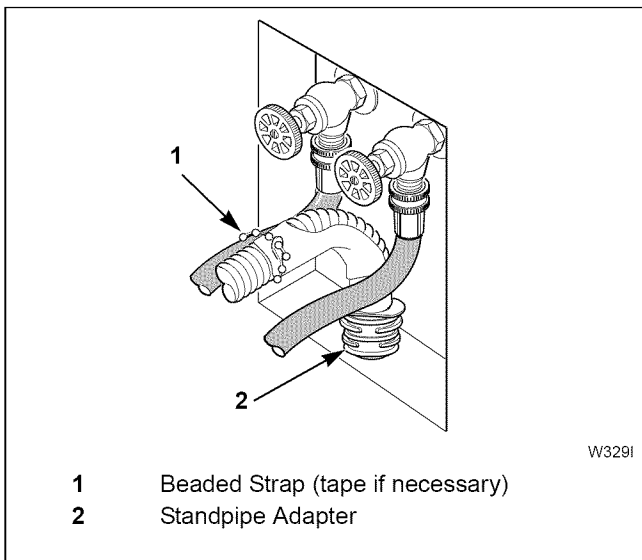

Figure 9

Step 5: Position and Level the Washer

Position washer so it has sufficient clearance for installation and servicing.

Place washer in position on a clean, dry and reasonably firm floor. Installing the washer on any type of carpeting is not recommended.

For easier access to leveling legs, prop up washer with a wooden block. Refer to *Figure 11*. Place rubber feet (supplied in accessories bag) on all four leveling legs. Refer to *Figure 12*.

Place a level on the cabinet top and check if the washer is level from side to side and front to back.

If washer is not level, tilt washer back to access the front leveling legs. Loosen the locknuts and adjust legs by screwing into or out of washer base.

Once adjusted, tilt the washer forward on front legs and lower back down into position to set the rear self-leveling legs.

Make sure that the washer does not rock. When washer is level and does not rock, tighten locknuts securely against bottom of washer base. If these locknuts are not tight, washer will not remain stationary during operation.

Improper installation or flexing of a weak floor will cause excessive vibration.

Do not slide washer across floor once the leveling legs have been extended. Legs and base could become damaged.

Verify that washer does not rock.

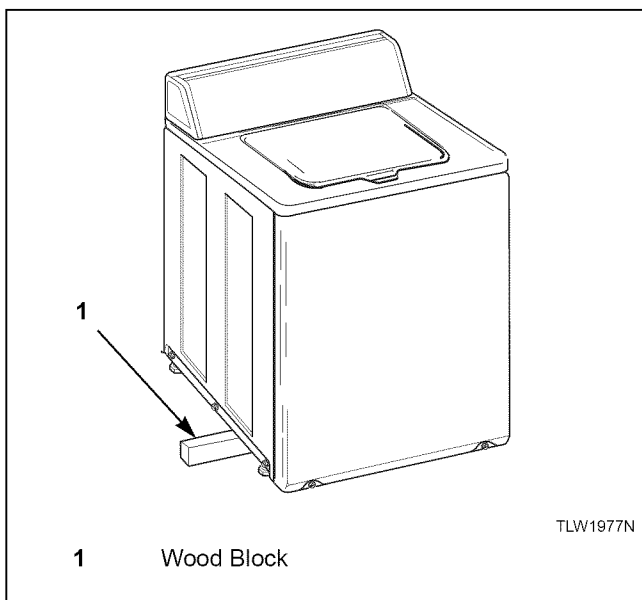

Figure 11

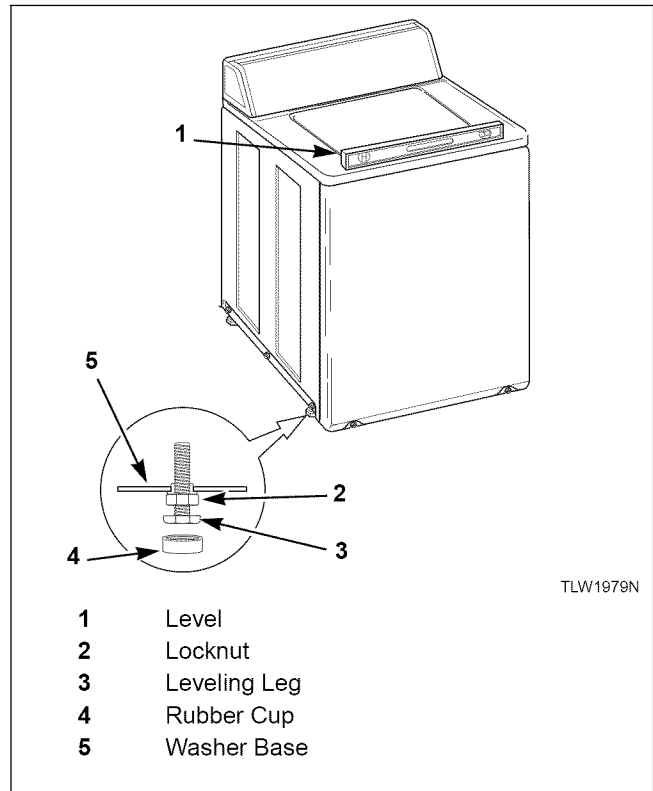

Figure 12

Step 6: Plug in the Washer

Washer requires 120 Volt, 60 Hertz electrical supply and comes equipped with a 3-Prong grounding plug. Refer to serial plate for specific electrical requirements.

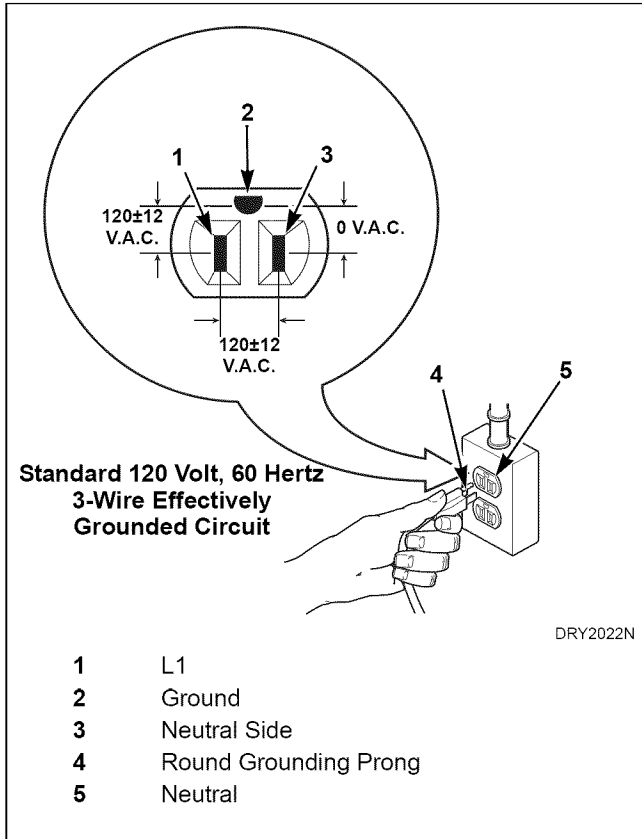

Figure 13

When plugging in the washer:

- DO NOT overload circuits.
- DO NOT use an extension cord.
- DO NOT use an adapter.
- DO NOT operate both a washer and gas dryer on the same circuit. Use separately fused 15 Amp circuits.

The washer is designed to be operated on a separate branch, polarized, three-wire, effectively grounded, 120 Volt, 60 Hertz, AC (alternating current) circuit protected by a **15 Amp fuse**, equivalent fusetron or circuit breaker.

The three-prong grounding plug on the power cord should be plugged directly into a polarized three-slot effectively grounded receptacle rated 110/120 Volts AC (alternating current) 15 Amps. Refer to *Figure 13* to determine correct polarity of the wall receptacle.

	WARNING
To reduce the risk of an electric shock or fire, DO NOT use an extension cord or an adapter to connect the washer to the electric power source.	
W082	

	WARNING
To reduce the risk of fire, electric shock, serious injury or death, all wiring and grounding MUST conform with the latest edition of the National Electrical Code, ANSI/NFPA No. 70, and such local regulations as might apply. It is the customer's responsibility to have the wiring, fuses and circuit breakers installed by a qualified electrician to make sure adequate electrical power is available to the washer.	
W518	

Grounding Information

The washer must be grounded. In the event of malfunction or breakdown, grounding will reduce the risk of electric shock by providing a path of least resistance for electric current.

The washer is equipped with a cord having an equipment-grounding conductor and a 3-prong grounding plug. The plug must be plugged into an appropriate outlet that is properly installed and grounded in accordance with all local codes and ordinances.

	WARNING
<p>Improper connection of the equipment-grounding conductor can result in a risk of electric shock. Check with a qualified electrician or service person if you are in doubt as to whether the washer is properly grounded.</p>	
<small>W216</small>	

Do not modify the plug provided with the washer - if it will not fit the outlet, have a proper outlet installed by a qualified electrician.

NOTE: Have a qualified electrician check the polarity of the wall receptacle. If a voltage reading is measured other than that in *Figure 13*, the qualified electrician should correct the problem.

	WARNING
<p>This unit is equipped with a three-prong (grounding) plug for your protection against shock hazard and should be plugged directly into a properly grounded three-prong receptacle. Do not cut or remove the grounding prong from this plug.</p>	
<small>W213</small>	

NOTE: The wiring diagram is located in the control hood.

Step 7: Add Water to the Washer

To prevent damage to pump, do not run washer before adding at least one quart water to the tub. If the washer is run before any water is added, the pump seal may overheat causing the pump to leak. Once installed, the water retained in the drain system from the previous cycle will provide sufficient cooling to prevent pump seal damage.

NOTE: The agitator should not be removed except for service. The washtub is designed to be self-cleaning.

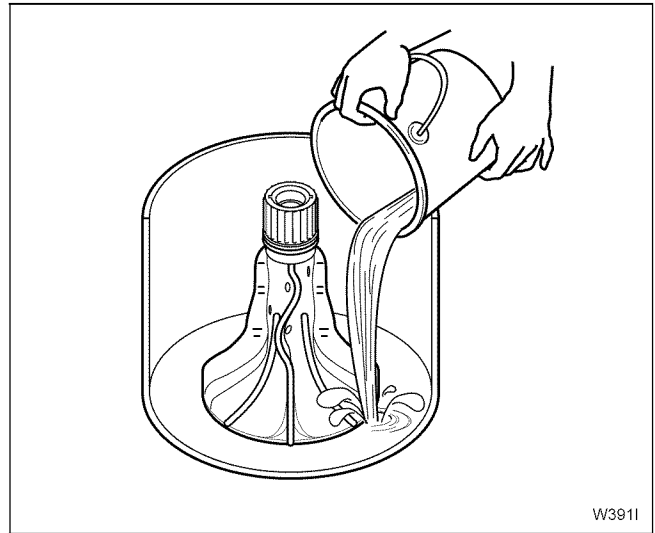

Figure 14

Step 8: Check Lid Switch

Washer should stop agitating and spinning when lid is opened.

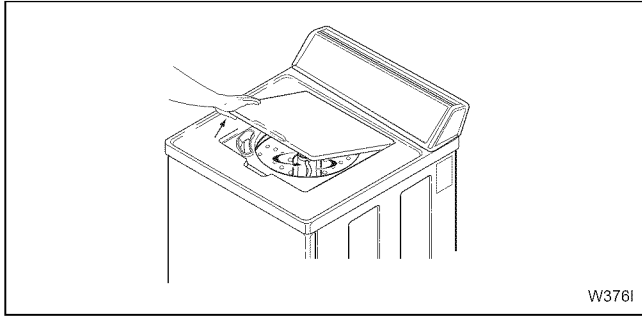

Figure 15

Step 9: Check Installation

Refer to *Installer Checklist* on the back cover of this manual and make sure that washer is installed correctly.

Run washer through one complete cycle to make sure it is operating properly.

Installer Checklist

Fast Track for Installing the Washer

(Refer to the manual for more detailed information)

1

- Remove the Shipping Brace and Shipping Plug.

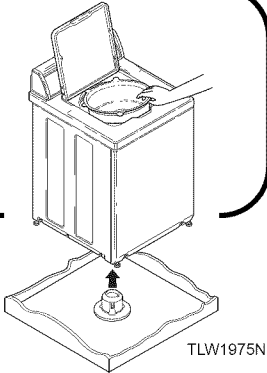

CHECK

TLW1975N

5

- Position and Level the Washer.

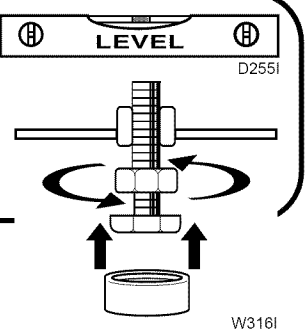

CHECK

D255I
W316I

2

- Wipe Out Inside of Washtub.

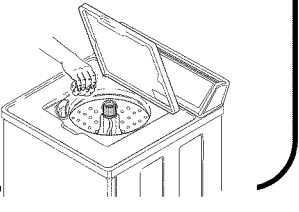

CHECK

TLW2009N

6

- Plug in the Washer.

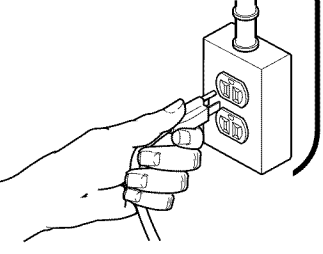

CHECK

D254I

3

- Connect Fill Hoses.

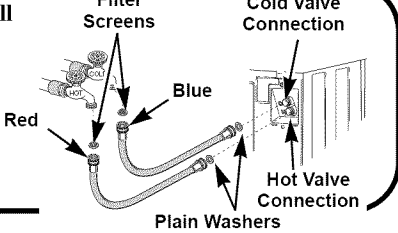

CHECK

TLW1988N

7

- Add Water to the Washer.

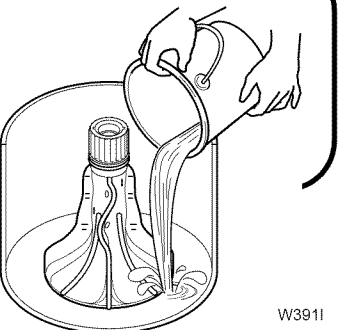

CHECK

W391I

4

- Connect Drain Hose to Drain Receptacle.

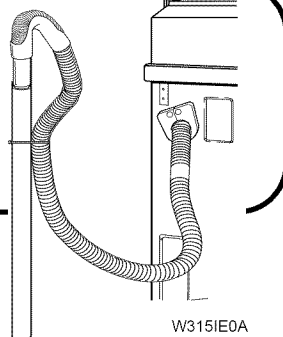

CHECK

W315IE0A

8

- Check Lid Switch.

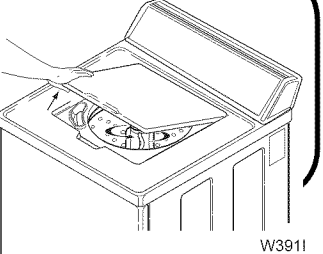

CHECK

W391I