

Installation Instructions

for Stacked Washers and Dryers



Inside.....

Dimensions.....	3
Before You Start.....	4
Installation.....	4
Installer Checklist	Back Cover

Date Purchased _____
Model Number _____
Serial Number _____

Para bajar una copia de estas instrucciones en español, visite www.speedqueen.com.

Keep these instructions for future reference.
(If this machine changes ownership, this manual must accompany machine.)



WARNING

FOR YOUR SAFETY, the information in this manual must be followed to minimize the risk of fire or explosion or to prevent property damage, personal injury or death.

W033

- Do not store or use gasoline or other flammable vapors and liquids in the vicinity of this or any other appliance.
- **WHAT TO DO IF YOU SMELL GAS:**
 - Do not try to light any appliance.
 - Do not touch any electrical switch; do not use any phone in your building.
 - Clear the room, building or area of all occupants.
 - Immediately call your gas supplier from a neighbor's phone. Follow the gas supplier's instructions.
 - If you cannot reach your gas supplier, call the fire department.
- Installation and service must be performed by a qualified installer, service agency or the gas supplier.

W052

- Installation of unit must be performed by a qualified installer.
- Install clothes dryer according to manufacturer's instructions and local codes.
- **DO NOT** install a clothes dryer with flexible plastic venting materials. If flexible metal (foil type) duct is installed, it must be of a specific type identified by the appliance manufacturer as suitable for use with clothes dryers. Refer to section on connecting exhaust system. Flexible venting materials are known to collapse, be easily crushed, and trap lint. These conditions will obstruct clothes dryer airflow and increase the risk of fire.

W729R1



WARNING

FOR YOUR SAFETY

Do not store or use gasoline or other flammable vapors and liquids in the vicinity of this or any other appliance.

W053

The following information applies to the state of Massachusetts, USA.

- This appliance can only be installed by a Massachusetts licensed plumber or gas fitter.
- This appliance must be installed with a 36 inch (91 cm) long flexible gas connector.
- A "T-Handle" type gas shut-off valve must be installed in the gas supply line to this appliance.
- This appliance must not be installed in a bedroom or bathroom.

© Copyright 2012, Alliance Laundry Systems LLC

All rights reserved. No part of the contents of this book may be reproduced or transmitted in any form or by any means without the expressed written consent of the publisher.

Dimensions

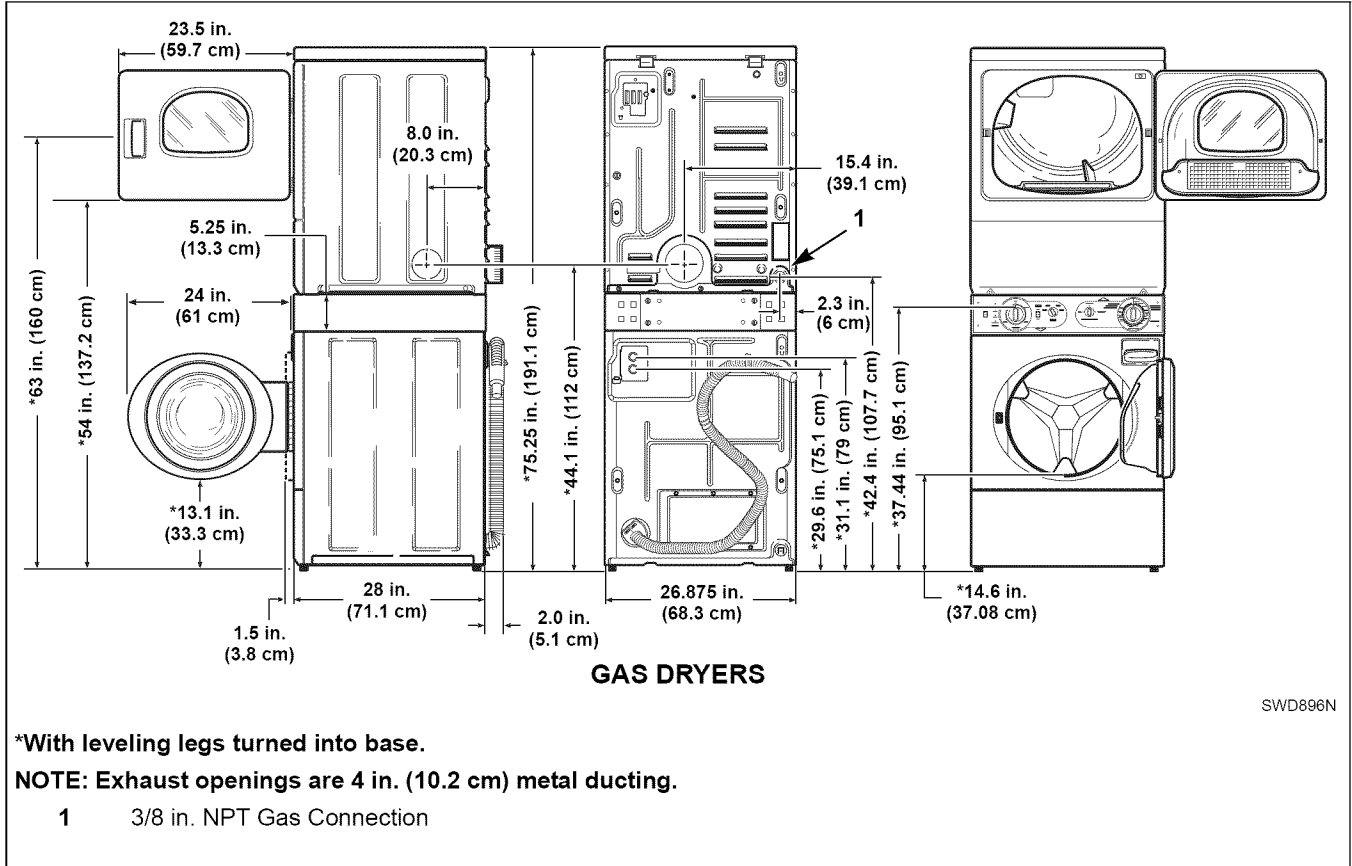
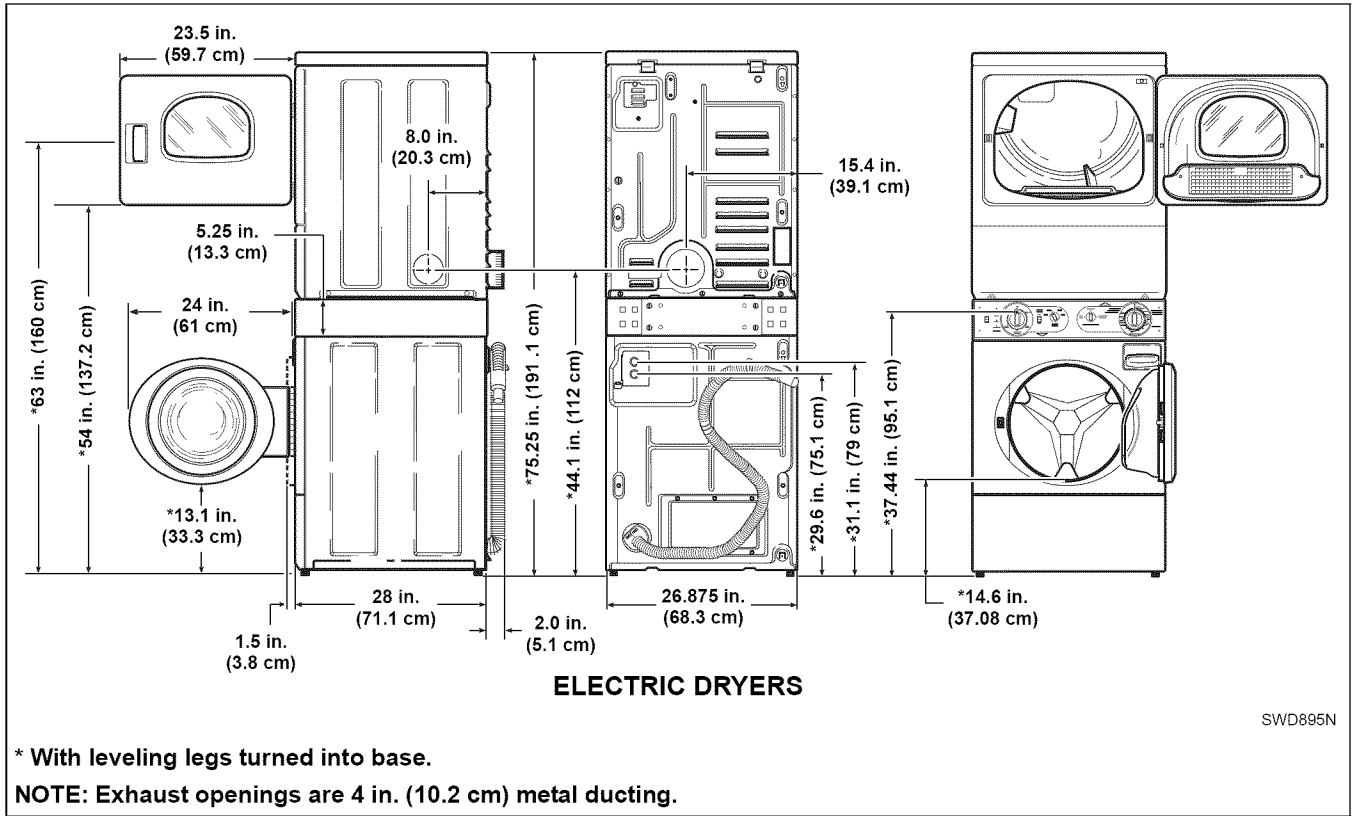

Before You Start

Supplies

For most installations, the basic supplies you will need are:

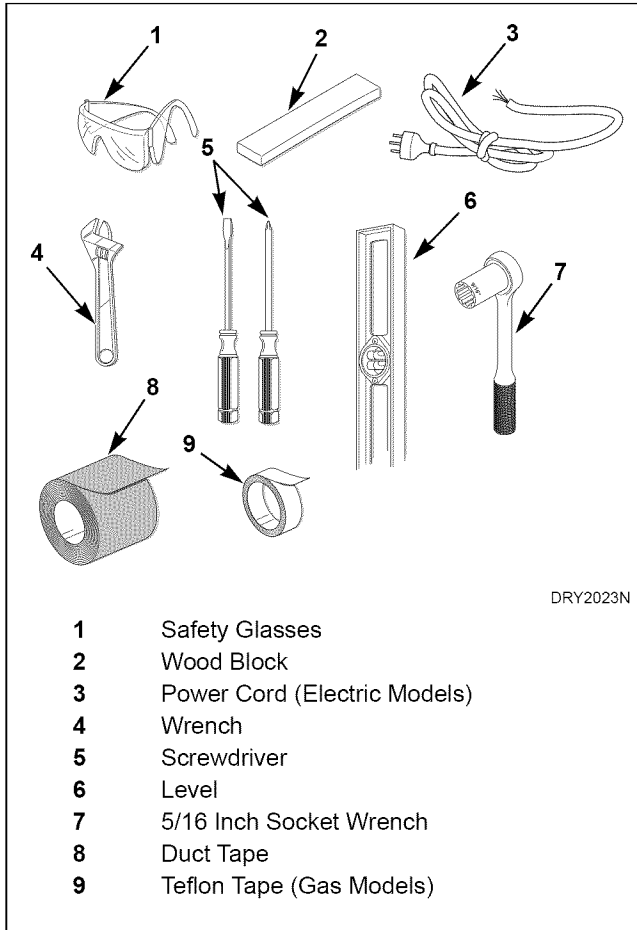

Figure 1

	WARNING
Any disassembly requiring the use of tools must be performed by a suitably qualified service person.	
W299	

Parts Included

An accessories bag has been shipped inside your unit. It includes:

- Installation Instructions
- Two User's Guide (one for washer and one for dryer)
- Warranty Bond
- Three screws (electric dryers only). Refer to *Connecting Power Cord* sections in Step 5 of *Installation*.
- Two fill hoses with washers and filter screens. Refer to Step 2 of *Installation*.
- Four rubber feet. Refer to Step 7 of *Installation*.
- Beaded strap. Refer to Step 3 of *Installation*.

NOTE: If the unit is delivered on a cold day (below freezing), or is stored in an unheated room or area during the cold months, do not attempt to operate it until the unit has had a chance to warm up.

NOTE: Some moisture in the wash drum is normal. Water is used during testing at the manufacturer.

Installation

Step 1: Position Unit Near Installation Area

Move unit as close to the desired area of installation as possible.

	WARNING
Washer and dryer are not designed to be operated as separated, side-by-side units.	
W187	

NOTE: For best performance and to minimize vibration or movement, install washer on a solid, sturdy and level floor. Some floors may need to be reinforced, especially on a second floor or over a basement. Do not install the washer on carpeting, soft tile, a platform or other weakly supported structures.

Step 2: Position and Level the Unit

Position unit so it has sufficient clearance for installation and servicing. Refer to *Figure 2*.

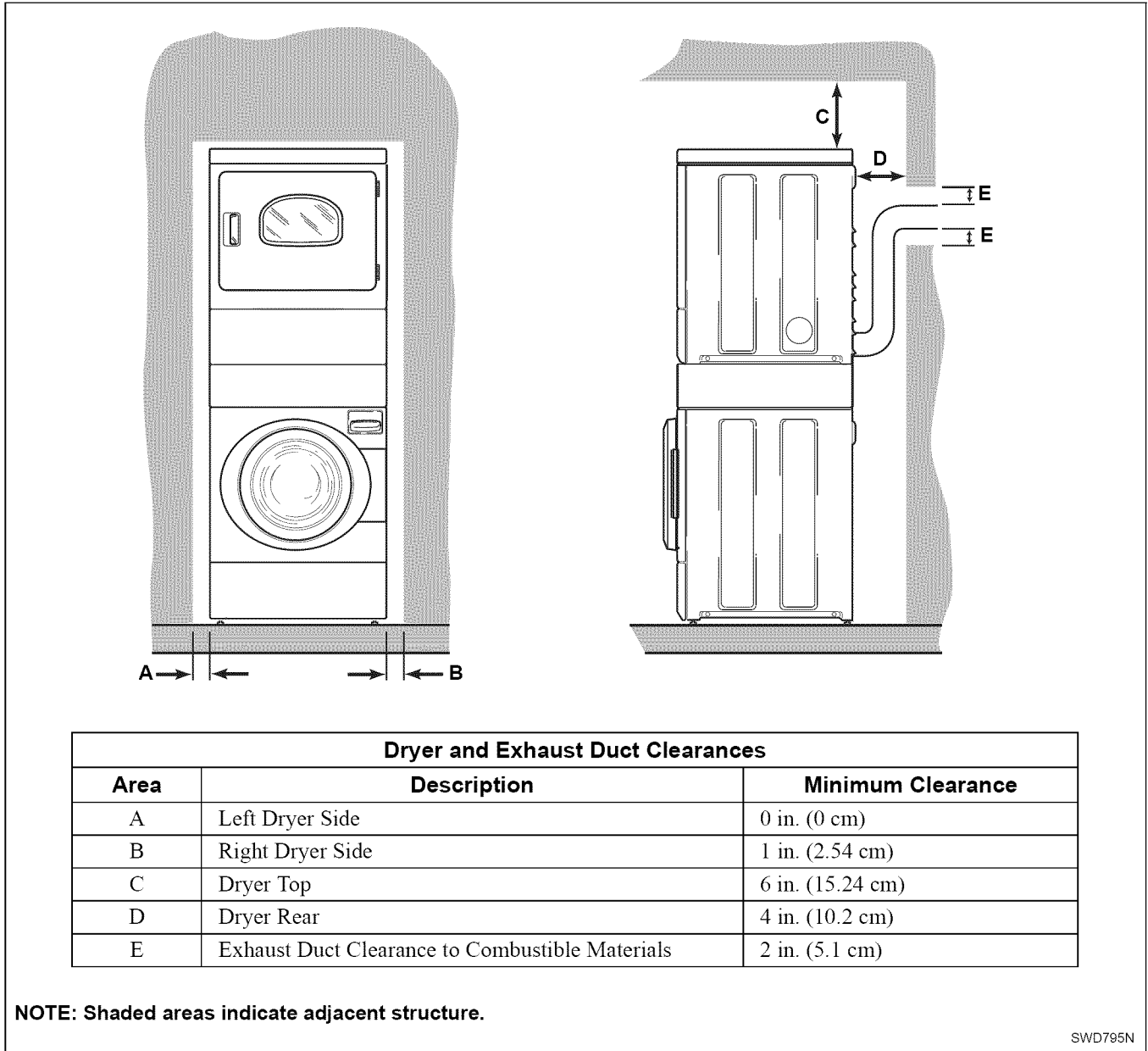

Figure 2

NOTE: Use of the dispenser drawer or unit doors as a handle in the transportation of the unit may cause damage to the dispenser or doors.

Place unit in position on a solid, sturdy and level floor. Installing the unit on any type of carpeting, soft tile, a platform or other weakly supported structures is not recommended.

Place a level on the cabinet top and check if the unit is level from side to side and front to back.

NOTE: Level must rest on raised portion of top panel. Refer to *Figure 3*.

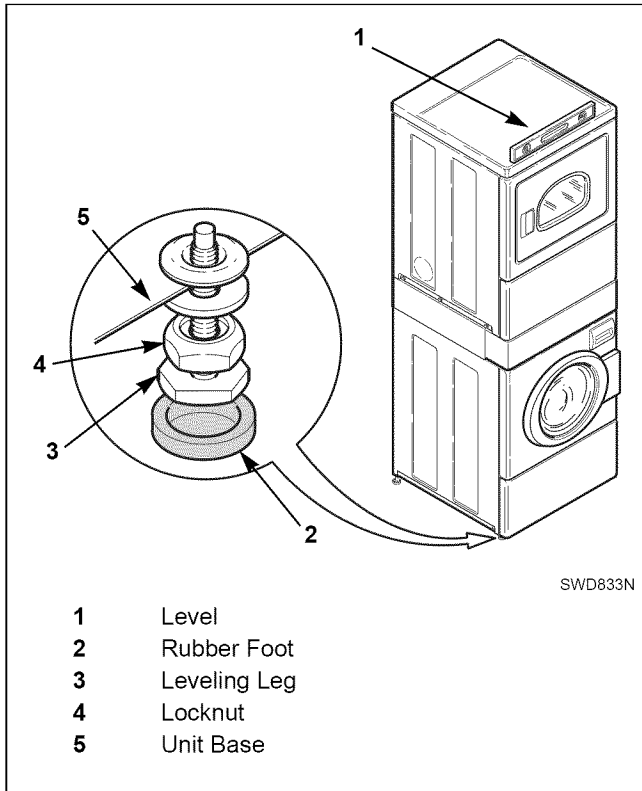

Figure 3

If unit is not level, tilt unit to access the front and rear leveling legs. For easier access to leveling legs, prop up unit with a wooden block. Refer to *Figure 4*. Loosen the locknuts and adjust legs by screwing into or out of unit base.

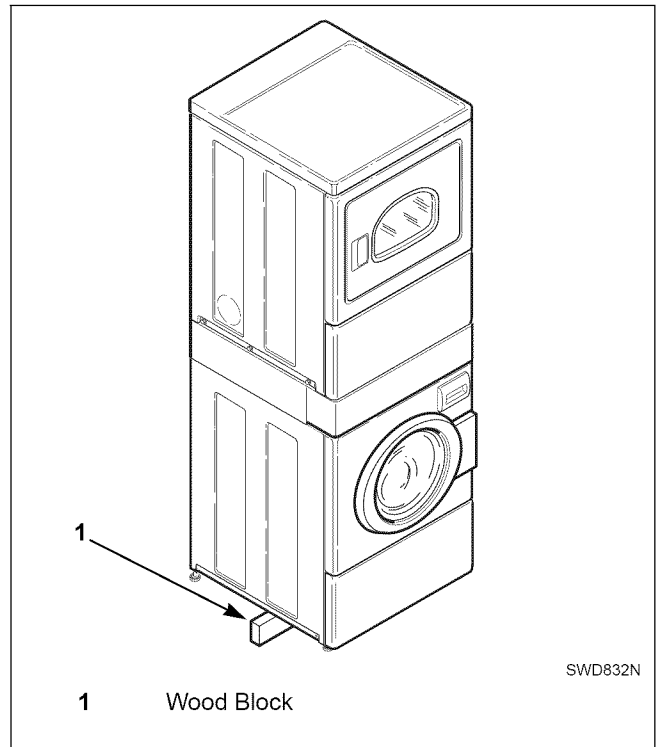

Figure 4

Make sure that the unit does not rock. When unit is level and does not rock, tighten locknuts securely against bottom of unit base. If these locknuts are not tight, unit will move out of position during operation.

Leveling legs can be adjusted from inside the unit with a 7/8 inch deep well socket. All four legs must rest firmly on the floor so the weight of the unit is evenly distributed. The unit must not rock and must be level from side-to-side and front-to-back.

NOTE: Do not slide unit across floor once the leveling legs have been extended. Legs and base could become damaged.

Place rubber feet (supplied in accessories bag) on all four leveling legs. Refer to *Figure 3*.

Verify that unit does not rock.

Step 3: Connect Fill Hoses

	WARNING
<p>Under certain conditions, hydrogen gas may be produced in a hot water system that has not been used for two weeks or more. HYDROGEN GAS IS EXPLOSIVE. If the hot water system has not been used for such a period and before using the washer, turn on all hot water faucets and let the water flow from each for several minutes. This will release any accumulated hydrogen gas. The gas is flammable. Do not smoke or use an open flame during this time.</p>	
W029	

Mixing Valve Flow Rates		
Pressure (psi)	HOT gallons per minute (liters per minute)	COLD gallons per minute (liters per minute)
20	1.6 (6)	2.5 (9.4)
40	2.2 (8.2)	3.4 (13)
60	2.6 (9.9)	3.8 (14.5)
100	2.5 (9.6)	4.2 (15.9)
120	2.6 (9.8)	4.2 (15.9)

Water Supply

Water supply faucets must fit standard 3/4 inch (19.1 mm) female garden hose couplings. **DO NOT USE SLIP-ON OR CLAMP-ON CONNECTIONS.**

Water supply faucets should be readily accessible to permit turning them off when washer is not being used.

Recommended cold water temperature is 60° to 80° Fahrenheit (16° to 27° Celsius). Recommended maximum hot water temperature is 125° Fahrenheit (51° Celsius). Warm water is a mixture of hot and cold water. Warm water temperature is dependent upon water temperature and pressure of both the hot and cold water supply lines.

	WARNING
<p>To prevent personal injury, avoid contact with inlet water temperatures higher than 125° Fahrenheit (51° Celsius) and hot surfaces.</p>	
W748	

Water pressure must be a minimum of 20 to a maximum of 120 pounds per square inch (138 to 827 kPa) static pressure measured at the faucet.

NOTE: Water pressure under 20 pounds per square inch (138 kPa) will cause an extended fill time in the washer and may not properly flush out the detergent dispenser.

Turn on the water faucets and flush the lines for approximately two minutes to remove any foreign material that could clog the screens in the water mixing valve.

NOTE: When installing in newly constructed or renovated buildings, it is very important to flush the lines since build-up may have occurred during construction.

Connecting Hoses

Remove the two plain rubber washers and two filter screens from the accessories bag. Install them into each end of the fill hoses as shown in *Figure 5*. The screen must be facing outward.

Screw hose couplings with the filter screens onto the water faucets until they are finger-tight. Then, using a pliers, screw approximately 1/4 turn. Use the red color-coded hose for the hot water connection and the blue color-coded hose for the cold water connection.

Screw hose couplings from other end of hoses onto the water mixing valve until they are finger-tight. Then, using a pliers, screw approximately 1/4 turn. Refer to *Figure 6*. Make sure the red color-coded hose from the hot water faucet goes to the water mixing valve marked “H” and the blue color-coded hose from the cold faucet goes to the valve marked “C”.

IMPORTANT: Do not cross thread or overtighten couplings. This will cause them to leak.

Turn water on and check for leaks. If leaks are found, turn off the water, unscrew hoses and reinstall them until there are no leaks.

IMPORTANT: Turn off water supply whenever there will be an extended period of non-use.

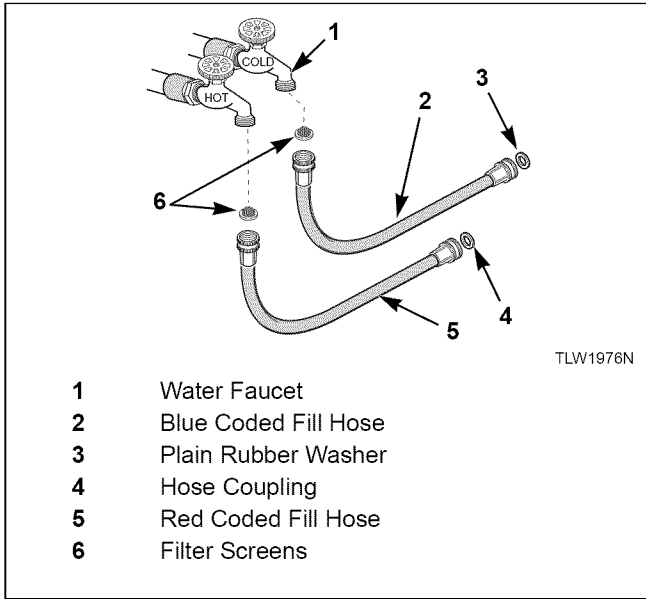

Figure 5

IMPORTANT: Hoses and other natural rubber parts deteriorate after extended use. Hoses may develop cracks, blisters or material wear from the temperature and constant high pressure they are subject to.

All hoses should be checked on a monthly basis for any visible signs of deterioration. Any hose showing the signs of deterioration listed above should be replaced immediately. All hoses should be replaced every five years.

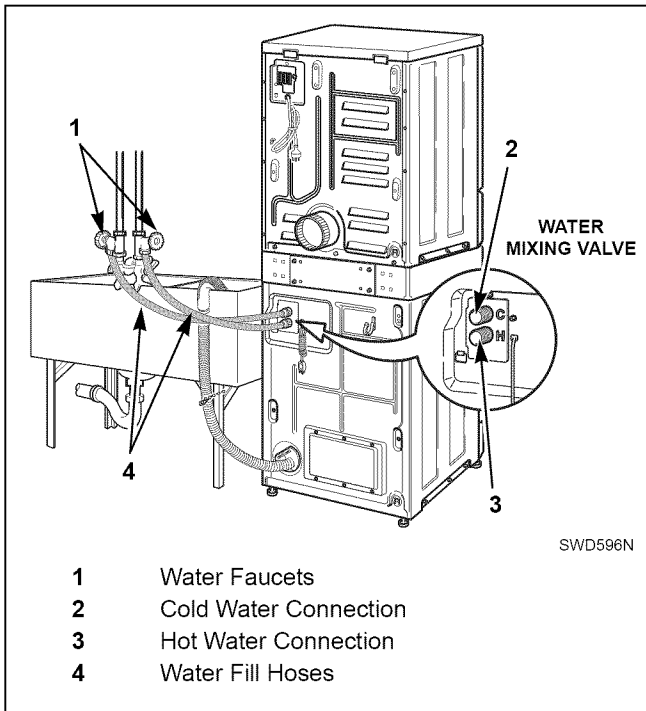

Figure 6

IMPORTANT: Turn off water supply faucets after check-out and demonstration. Owner should turn off water supply whenever there will be an extended period of non-use.

NOTE: Longer fill hoses are available (as optional equipment at extra cost) if the hoses supplied with the washer are not long enough for the installation. Order hoses as follows:

No. 20617 Fill Hose (8 feet) (2.44 m)

No. 20618 Fill Hose (10 feet) (3.05 m)

Risers

Risers (or air cushions) may have to be installed if the pipes knock or pound when flow of water stops. The risers are more efficient when installed as close as possible to the water supply faucets (refer to *Figure 7*).

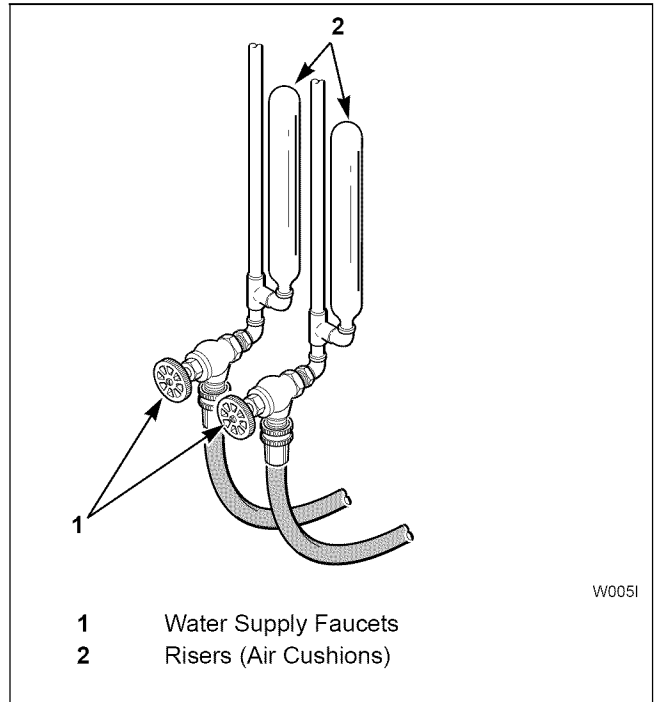

Figure 7

Step 4: Connect Drain Hose to Drain Receptacle

Remove the drain hose from its shipping position on the rear of the washer by unhooking the hose from the retainer clamp and by removing the shipping tape.

Install the drain hose into the drain receptacle (standpipe, wall or laundry tub) following the instructions below.

IMPORTANT: Drain receptacle must be capable of handling a minimum of 1-1/4 inch (32 cm) outside diameter drain hose.

Drain Flow Rate	
Drain Height	Flow Rate gallons per minute (liters per minute)
3 ft. (0.9 m)	8.19 (31)
5 ft. (1.5 m)	7.27 (27.5)
6 ft. (1.8 m)	6.31 (23.9)
7 ft. (2.1 m)	4.89 (18.5)
8 ft. (2.4 m)	2.79 (10.6)

Standpipe Installation:

Place the drain hose into the standpipe.

Remove the beaded strap from accessories bag and place around standpipe and drain hose and tighten strap to hold hose to standpipe. Refer to *Figure 8*. This will prevent the drain hose from dislodging from drain receptacle during use.

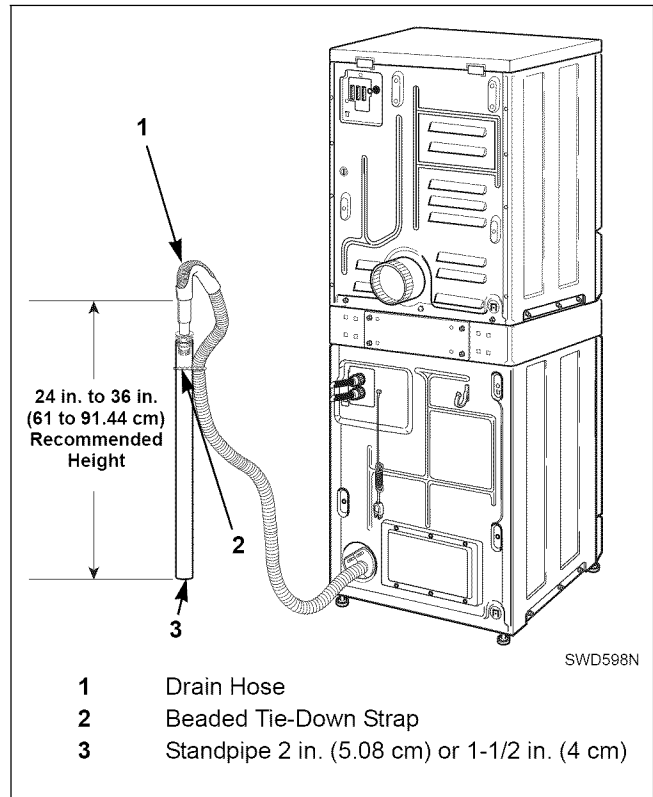

Figure 8

Wall Installation:

For installations of this type, the drain hose **MUST** be secured to one of the fill hoses using the beaded strap from accessories bag. Refer to *Figure 9*.

NOTE: End of drain hose must not be below 24 in. (61 cm).

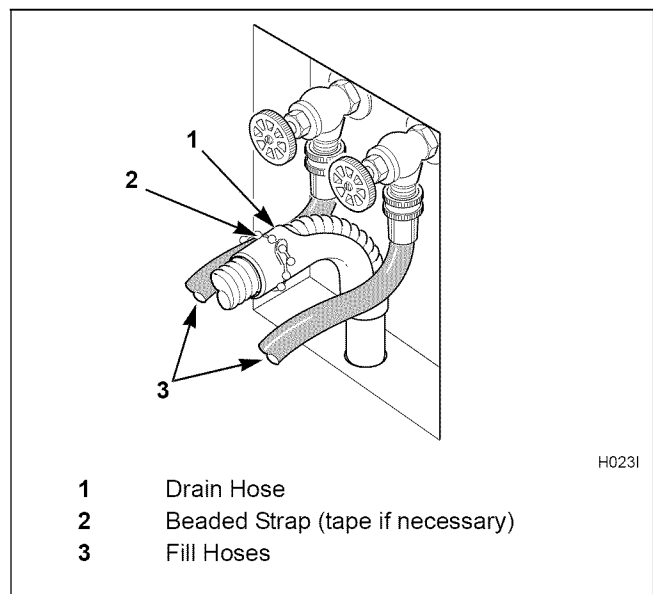

Figure 9

Laundry Tub Installation:

For this type of installation, the drain hose MUST be secured to the stationary tub to prevent hose from dislodging during use. Refer to *Figure 10*. Use the beaded strap (supplied in accessories bag) to secure hose.

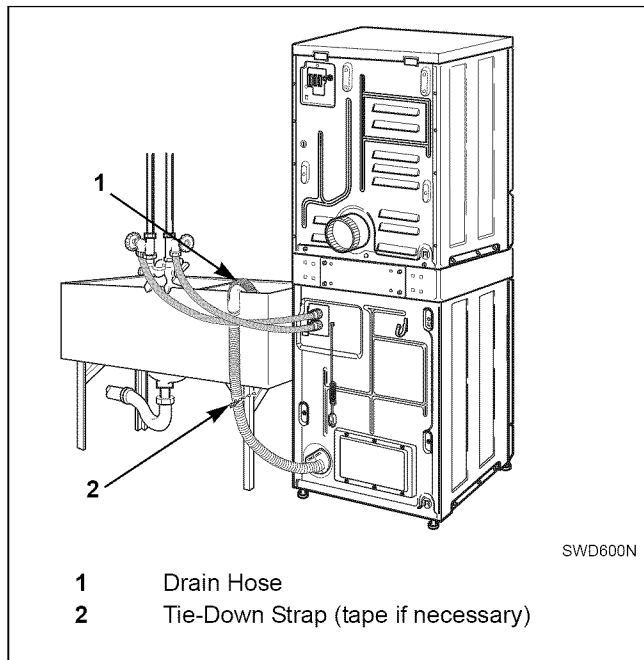

Figure 10

Step 5: (Gas Dryer Only) Connect Gas Supply Pipe



WARNING

To reduce the risk of gas leaks, fire or explosion:

- The dryer must be connected to the type of gas as shown on nameplate located in the door recess.
- Use a new flexible stainless steel connector.
- Use pipe joint compound insoluble in L.P. (Liquefied Petroleum) Gas, or Teflon tape, on all pipe threads.
- Purge air and sediment from gas supply line before connecting it to the dryer. Before tightening the connection, purge remaining air from gas line to dryer until odor of gas is detected. This step is required to prevent gas valve contamination.
- Do not use an open flame to check for gas leaks. Use a non-corrosive leak detection fluid.
- Any disassembly requiring the use of tools must be performed by a suitably qualified service person.

W316

1. Make certain your dryer is equipped for use with the type of gas in your laundry room. Dryer is equipped at the factory for **Natural Gas** with a 3/8 inch NPT gas connection.

NOTE: The gas service to a gas dryer must conform with the local codes and ordinances, or in the absence of local codes and ordinances, with the latest edition of the National Fuel Gas Code ANSI Z223.1/NFPA 54 or the CAN/CSA - B149.1 Natural Gas and Propane Installation Code.

Natural Gas, 1000 Btu/ft³ (37.3 MJ/m³) service must be supplied at minimum 5.0 inch water column pressure to maximum 10.5 inch water column pressure.

For proper operation at altitudes above 3000 feet (915 m) the natural gas valve spud orifice size must be reduced to ensure complete combustion. Refer to *Table 1*.

Natural Gas Altitude Adjustments					
Altitude		Orifice Size			Part No.
feet	m	No.	inches	mm	
3000	915	43	0.0890	2.26	503778
6000	1830	44	0.0860	2.18	58719
8000	2440	45	0.0820	2.08	503779
9000	2740	46	0.0810	2.06	503780
10,000	3050	47	0.0785	1.99	503781

Table 1

- Remove the shipping cap from the gas connection at the rear of the dryer. Make sure you do not damage the pipe threads when removing the cap.
- Connect to gas supply pipe.

NOTE: When connecting to a gas line, an equipment shut-off valve must be installed within 6 feet (1.8 m) of the dryer. An 1/8 in. NPT pipe plug must be installed as shown for checking inlet pressure. Refer to *Figure 11*.

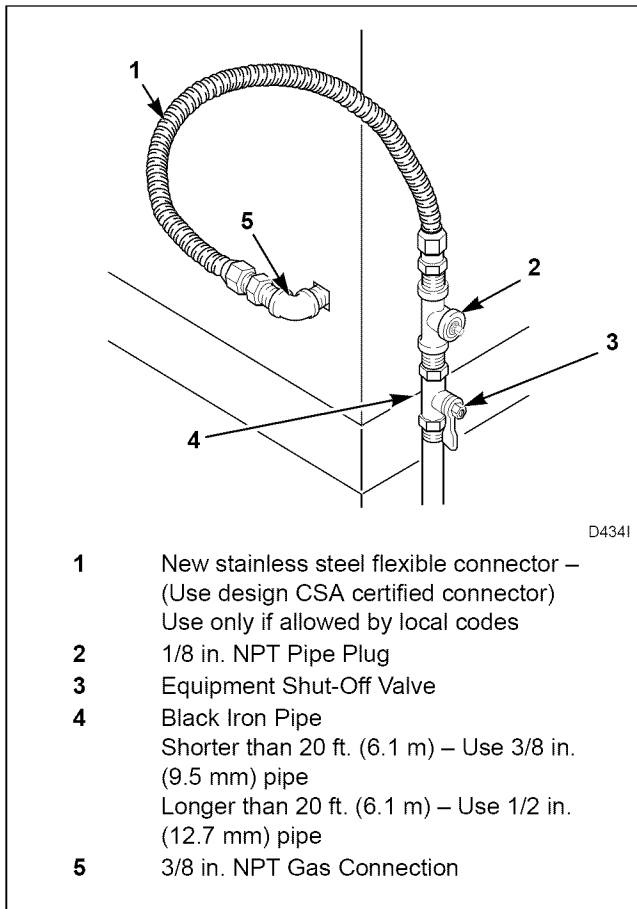

Figure 11

- Tighten all connections securely. Turn on gas and check all pipe connections (internal & external) for gas leaks with a non-corrosive leak detection fluid.

NOTE: The dryer and its appliance main gas valve must be disconnected from the gas supply piping system during any pressure testing of that system at test pressures in excess of 1/2 psi (3.45 kPa). Refer to *Step 12 (Check Heat Source)*.

L.P. (Liquefied Petroleum) Gas, 2500 Btu/ft³ (93.1 MJ/m³) service must be supplied at 10 ± 1.5 inch water column pressure.

For proper operation at altitudes above 3000 feet (915 m) the L.P. gas valve spud orifice size must be reduced to ensure complete combustion. Refer to *Table 2*.

L.P. Altitude Adjustments					
Altitude		Orifice Size			Part No.
feet	m	No.	inches	mm	
3000	915	55	0.0520	1.32	58755
8000	2440	56	0.0465	1.18	503786

Table 2

NOTE: DO NOT connect the dryer to L.P. Gas Service without converting the gas valve. Install L.P. Gas Conversion Kit 649P3, available at extra cost.

Step 6: (Electric Dryer Only) Connect Electrical Plug

Dryer requires 120/240 Volt or 120/208 Volt, 60 Hertz, 3 or 4 wire electrical supply. Refer to serial plate for specific electrical requirements.

NOTE: The wiring diagram is located behind the control panel, inside the control cabinet.

	WARNING
<p>To reduce the risk of fire, electric shock, serious injury or death, all wiring and grounding MUST conform with the latest edition of the National Electrical Code, ANSI/NFPA 70, or the Canadian Electrical Code, CSA C22.1, and such local regulations as might apply. It is the customer's responsibility to have the wiring and fuses installed by a qualified electrician to make sure adequate electrical power is available to the dryer.</p>	
W521	

Grounding Information

- This dryer must be connected to a grounded metal, permanent wiring system; or an equipment-grounding conductor must be run with the circuit conductors and connected to the equipment-grounding terminal or lead on the dryer.
- The dryer has its own terminal block that must be connected to a separate branch, 60 Hertz, single phase circuit, AC (alternating current) circuit, **fused at 30 Amperes** (the circuit must be fused on both sides of the line). **Electrical service for the dryer should be of maximum rated voltage (208 or 240 volt, depending on heating element) listed on the nameplate. Do not connect dryer to 110, 115, or 120 volt circuit.**
- Heating elements are available for field installation in dryers which are to be connected to electrical service of different voltage than that listed on nameplate, such as 208 Volt.

NOTE: Branch circuit wire size requirements to laundry room outlet are shown in *Table 3*.

Wire Length	Dryer
Less than 15 ft. (4.5 m)	Listed No. 10 AWG Copper wire only
Longer than 15 ft. (4.5 m)	Listed No. 8 AWG Copper wire only

Table 3

- The power cord connection between wall receptacle and dryer terminal block **IS NOT supplied with dryer**. Type of power cord and gauge of wire must conform to local codes.

Connecting Power Cord with Three-Wire Plug

NOTE: Four-wire cord is required for mobile homes or where codes do not permit grounding through neutral.

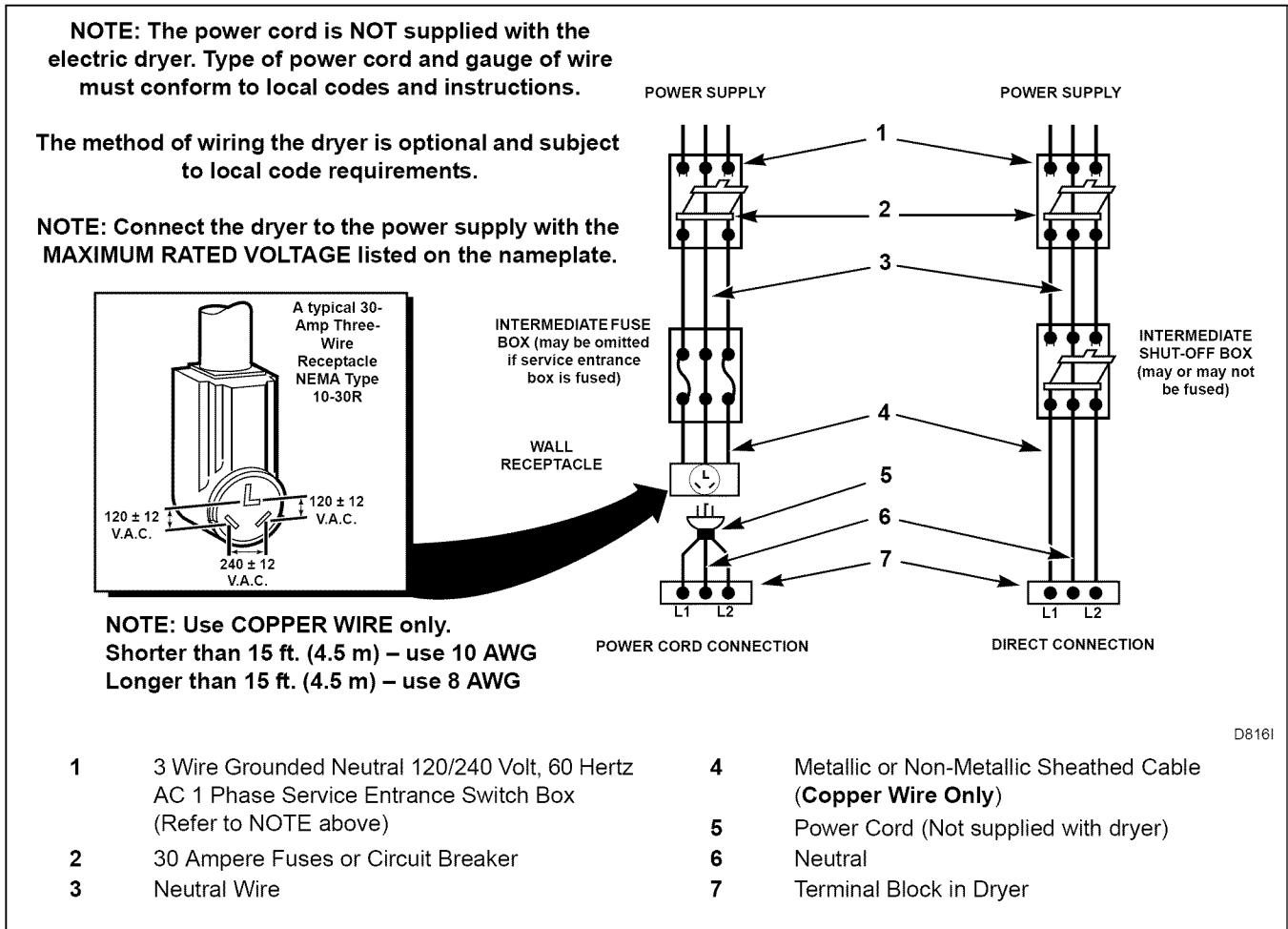

Figure 12

1. Disconnect power to dryer.
2. Remove access cover from rear of dryer.

3. Use a strain relief and insert end of power cord through power supply hole.

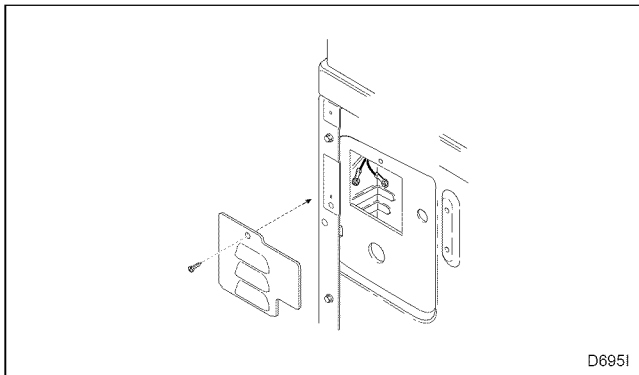

Figure 13

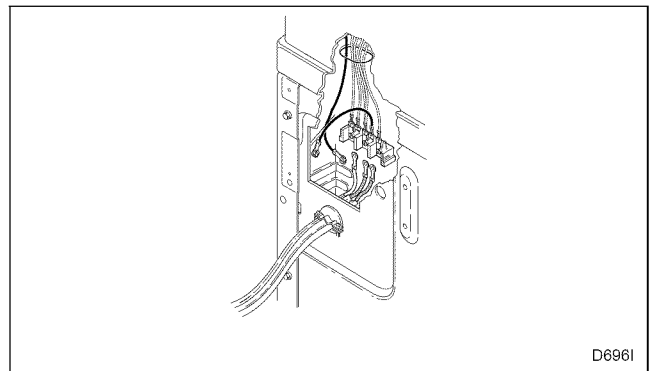

Figure 14

- Use the three screws from the accessories bag to attach the power cord wires to the terminal block. Refer to *Figure 15*.

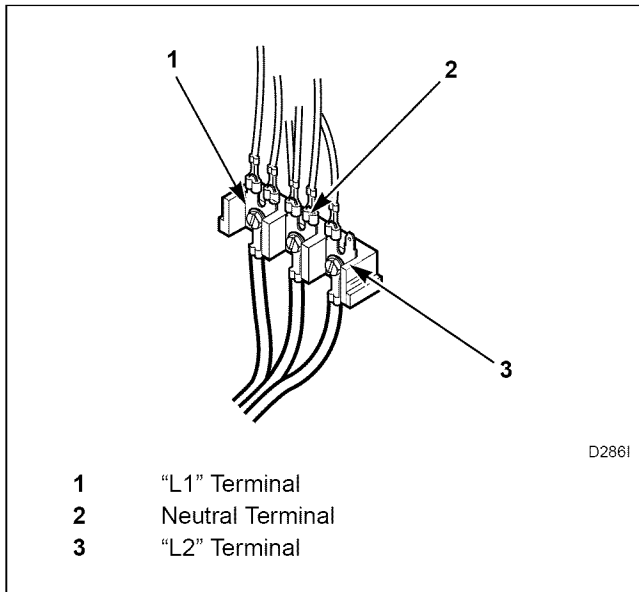

Figure 15

- Tighten all screws firmly.

IMPORTANT: Failure to tighten these screws firmly may result in wire failure at the terminal block.

- Secure the strain relief to the power cord, or wires, where they enter the dryer cabinet.
- Check the continuity of the ground connection before plugging the cord into an outlet. Use an acceptable indicating device connected to the center grounding pin of the plug and the green screw on the back of the cabinet.
- Reinstall access cover and screw.

Connecting Power Cord with Four-Wire Plug

NOTE: Four-wire cord is required for mobile homes or where codes do not permit grounding through neutral.

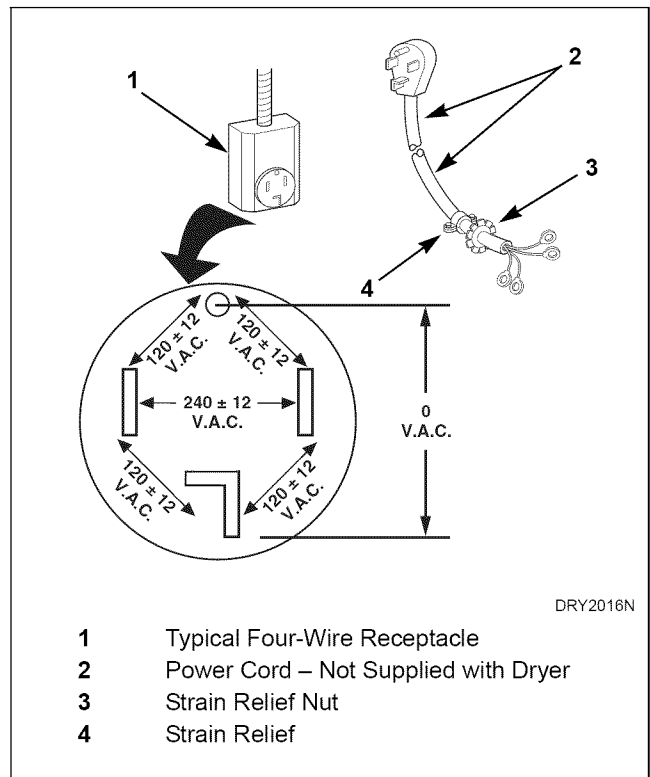

Figure 16

- Disconnect power to dryer.
- Remove access cover from rear of dryer.

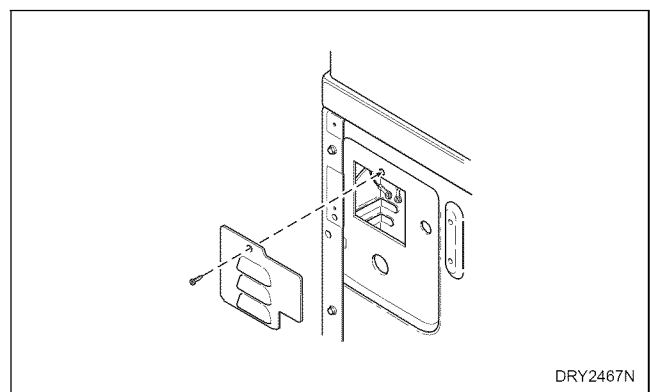

Figure 17

3. Remove ground screw from ground to neutral wire and save for use in Step 5. Ground to neutral wire will be attached to the neutral terminal in Step 6.

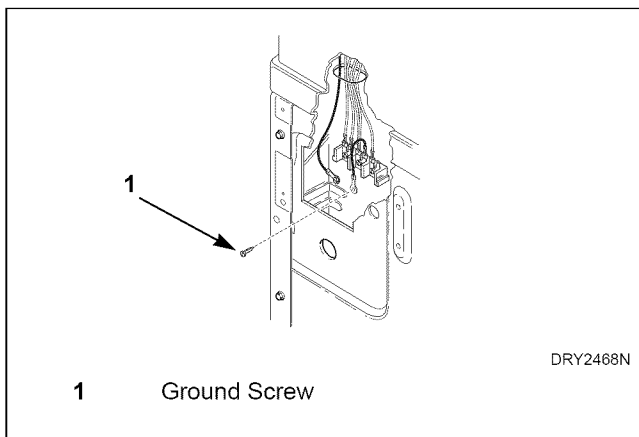

Figure 18

4. Use a strain relief and insert end of power cord through power supply hole.

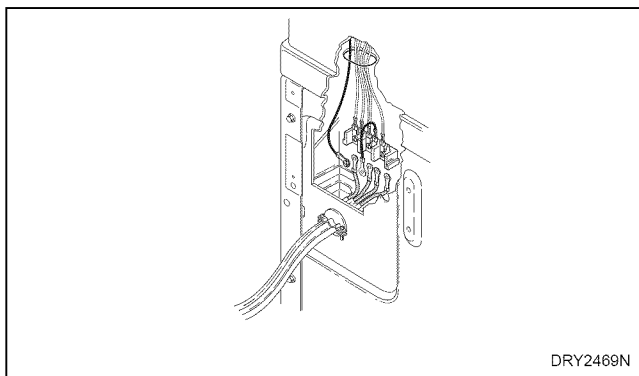

Figure 19

5. Attach power cord ground (green) wire to rear bulkhead using ground screw removed in Step 3.

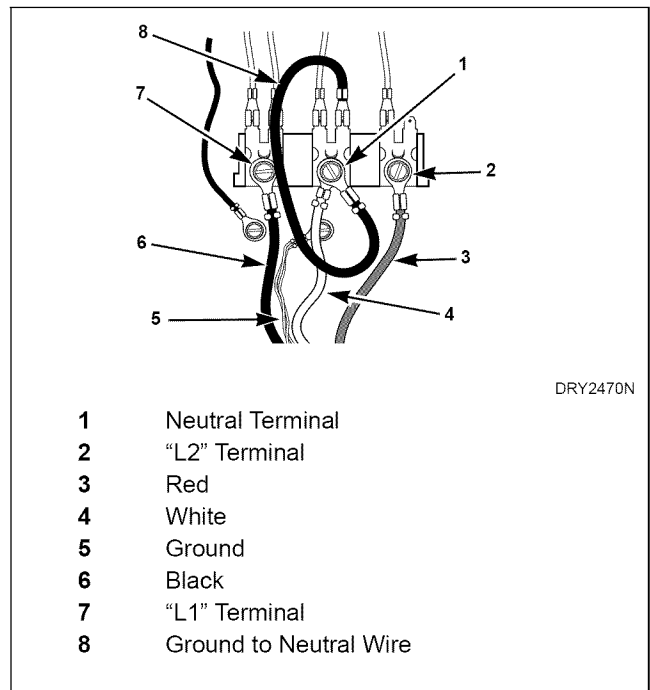

Figure 20

6. Use the three screws from the accessories bag to attach the remaining power cord wires to the terminal block as follows:
 - a. Red wire to "L1" terminal.
 - b. Black wire to "L2" terminal.
 - c. White wire to Neutral terminal.



NOTE: When installing the white wire, loop the free eyelet end of the ground to neutral wire (removed in Step 3) and attach along with the white wire to the neutral (center) terminal on the terminal block.

7. Tighten all screws firmly.

IMPORTANT: Failure to tighten these screws firmly may result in wire failure at the terminal block.

8. Secure the strain relief to the power cord, or wires, where they enter the dryer cabinet.
9. Check the continuity of the ground connection before plugging the cord into an outlet. Use an acceptable indicating device connected to the center grounding pin of the plug and the green screw on the back of the control cabinet.
10. Reinstall access cover and screw.

Step 7: Connect Dryer Exhaust System

	WARNING
<p>To reduce the risk of fire and combustion gas accumulation the dryer MUST be exhausted to the outdoors.</p> <p style="text-align: right;">W604</p>	
<p>To reduce the risk of fire and the accumulation of combustion gases, DO NOT exhaust dryer air into a window well, gas vent, chimney or enclosed, unventilated area, such as an attic, wall, ceiling, crawl space under a building or concealed space of a building.</p> <p style="text-align: right;">W045</p>	
	WARNING
<p>This gas appliance contains or produces a chemical or chemicals which can cause death or serious illness and which are known to the State of California to cause cancer, birth defects, or other reproductive harm. To reduce the risk from substances in the fuel or from fuel combustion, make sure this appliance is installed, operated, and maintained according to the instructions in this manual.</p> <p style="text-align: right;">W115</p>	
<p>To reduce the risk of fire, DO NOT use plastic or thin foil ducting to exhaust the dryer.</p> <p style="text-align: right;">W354</p>	

- DO NOT use plastic, thin foil or type B ducting. Rigid metal duct is recommended. Refer to *Figure 21*.

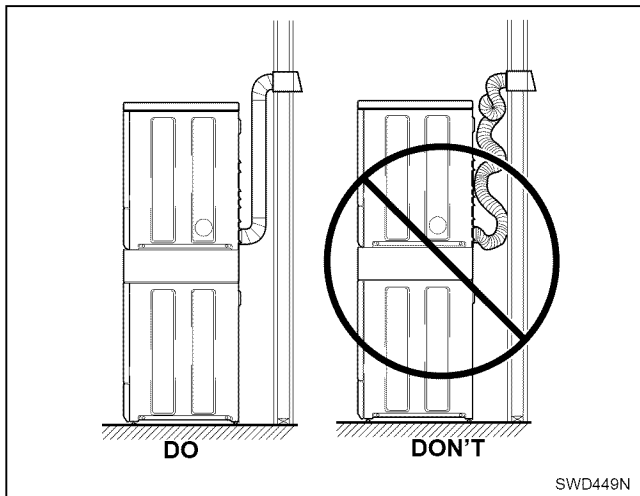

Figure 21

- Locate dryer so exhaust duct is as short as possible.
- Be certain old ducts are cleaned before installing your new dryer.
- Use 4 inch (102 mm) diameter rigid or flexible metal duct.
- The male end of each section of duct must point away from the dryer.
- Use as few elbows as possible.
- Use of duct tape or pop-rivets on all seams and joints is recommended, if allowed by local codes. DO NOT use sheet metal screws or fasteners on exhaust pipe joints which extend into the duct and catch lint.
- Ductwork that runs through unheated areas must be insulated to help reduce condensation and lint build-up on pipe walls.
- In mobile home installations, dryer exhaust duct must be secured to mobile home structure.
- Dryer exhaust duct **MUST NOT** terminate under mobile home.
- Dryer exhausts 220 cfm (measured at back of dryer).
- DO NOT install flexible duct in concealed spaces, such as a wall or ceiling.
- Static pressure in exhaust duct should not be greater than .6 inches water column (1.5 cm), measured with manometer placed on exhaust duct 2 feet (61 cm) from dryer (check with dryer running and no load).
- Exhausting dryer in hard-to-reach locations can be done by installing 521P3 Flexible Metal Vent Kit (available as optional equipment at extra cost).
- Sufficient make-up air must be supplied to replace the air exhausted by the dryer. The free area of any opening for outside air must be at least 40 in.² (260 cm²).
- **Failure to exhaust dryer properly will void warranty.**

NOTE: Venting materials are not supplied with the dryer (obtain locally).

IMPORTANT: DO NOT block the airflow at the bottom of the dryer's front panel with laundry, rugs, etc. Blockage will decrease airflow through the dryer, thus reducing the efficiency of the dryer.

Exhaust Direction

The dryer can be exhausted to the outdoors through the back, left, right or bottom of the dryer. **EXCEPTION: Gas dryers cannot be vented out the left side because of the burner housing.**

Dryer is shipped from factory ready for rear exhaust.

Exhausting the dryer through sides or bottom can be accomplished by installing a Directional Exhaust Kit, 528P3, available as optional equipment at extra cost.

Exhaust System

For best drying results, recommended maximum length of exhaust system is shown in *Table 4*.

To prevent backdraft when dryer is not in operation, outer end of exhaust pipe must have a weather hood with hinged dampers (obtain locally).

NOTE: Weather hood should be installed at least 12 inches (30.5 cm) above the ground. Larger clearances may be necessary for installations where heavy snowfall can occur.

Number of 90° Elbows	Weather Hood Type	
	Recommended	Use Only for Short Run installations
	 4 in. (10.2 cm)	 2-1/2 in. (6.35 cm)
	D673I	D802I
Maximum length of 4 in. (10.2 cm) diameter rigid metal duct.		
0	65 feet (19.8 m)	55 feet (16.8 m)
1	55 feet (16.8 m)	47 feet (14.3 m)
2	47 feet (14.3 m)	41 feet (12.5 m)
3	36 feet (11.0 m)	30 feet (9.1 m)
4	28 feet (8.5 m)	22 feet (6.7 m)
NOTE: Deduct 6 feet (1.8 m) for each additional elbow.		

Table 4

NOTE: The maximum length of a 4 in. (10.2 cm) diameter flexible metal duct must not exceed 7.87 ft. (2.4 m), as required to meet UL2158, clause 7.3.2A.

Step 8: Remove the Shock Sleeves and Shipping Brace

1. Remove panel.

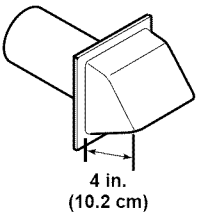
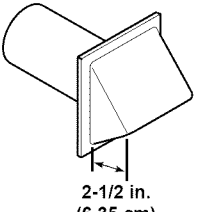
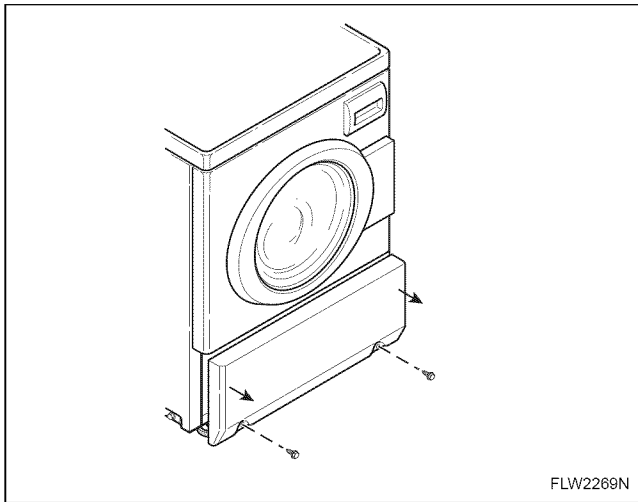

Figure 22

2. Remove brace. Five bolts secure brace to machine. For easier removal, remove in order shown.

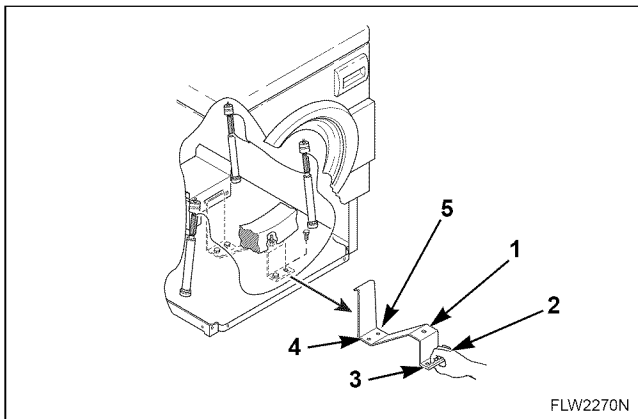

Figure 23

3. Remove shock sleeves.

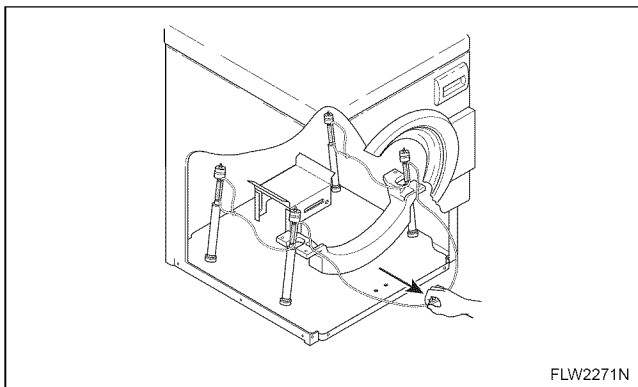

Figure 24

4. Replace panel.

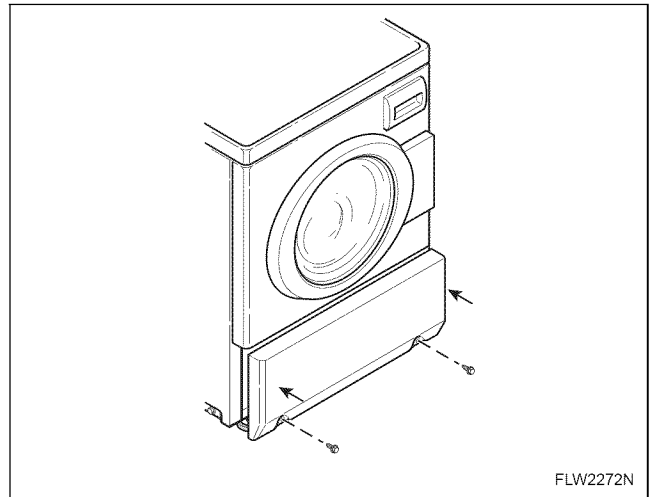

Figure 25

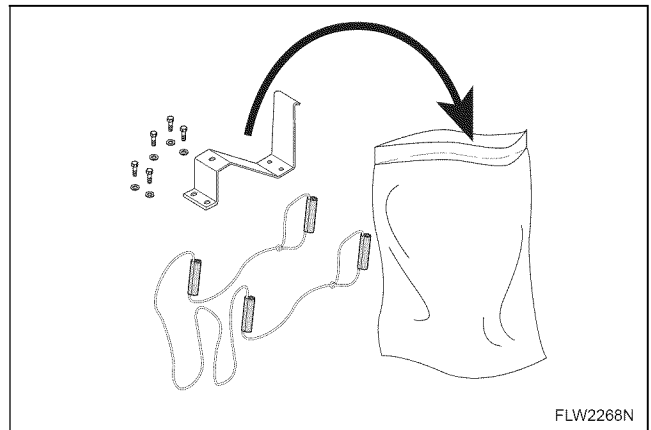

Figure 26

IMPORTANT: The shipping brace, bolts, lockwashers and shock sleeves should be saved and **MUST** be reinstalled whenever the unit is moved more than four feet. Do not lift or transport unit from front or without shipping materials installed. Refer to the User's Guide for proper instructions on reinstalling the shipping materials.

IMPORTANT: DO NOT tip washer more than 6 inches (152.4 mm) in any direction after shipping brace has been removed. Shock absorbers may separate and damage to washer may result. For leveling purposes, the washer may be tilted a maximum of 6 inches (152.4 mm) in any direction.

Step 9: Wipe Out Inside of Washer Drum and Dryer Drum

Before using the washer and dryer for the first time, use an all-purpose cleaner, or a detergent and water solution, and a damp cloth to remove shipping dust from inside the drums.

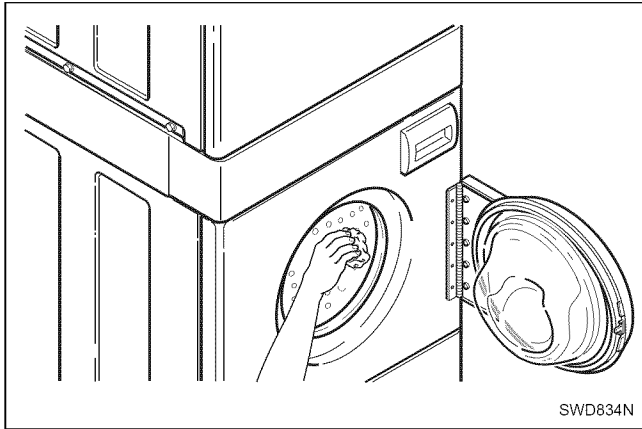

Figure 27

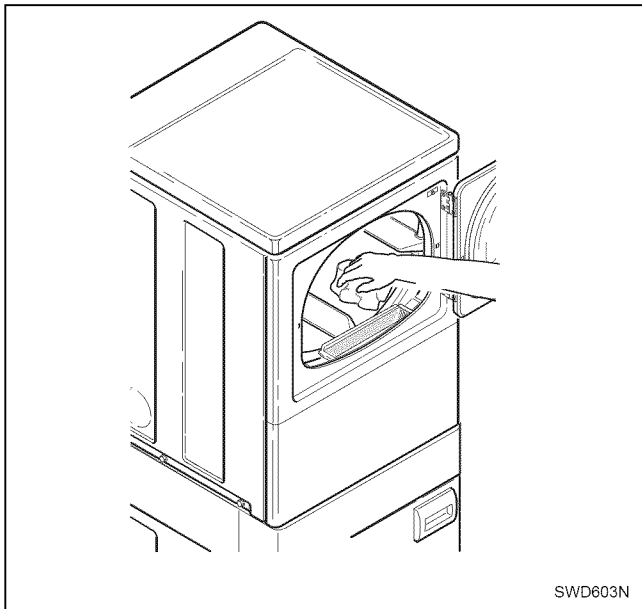

Figure 28

Step 10: Plug In the Washer and Dryer

Electric Dryer

Connect the dryer to an electrical power source. Refer to Step 4 for information on connecting power cord.

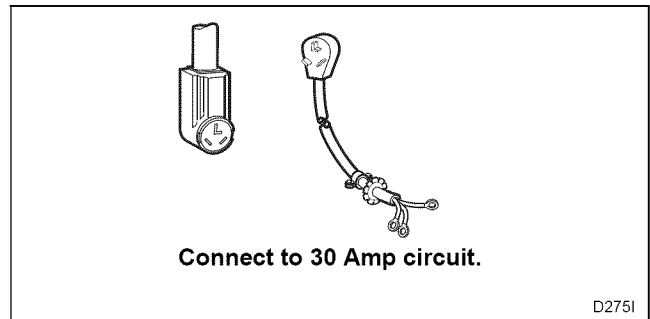

Figure 29

Gas Dryer

Dryer requires 120 Volt, 60 Hertz electrical supply and comes equipped with a 3-prong grounding plug. Refer to serial plate for specific electrical requirements.

NOTE: The wiring diagram is located behind the control panel, inside the control cabinet.

	WARNING
<p>To reduce the risk of fire, electric shock, serious injury or death, all wiring and grounding MUST conform with the latest edition of the National Electrical Code, ANSI/NFPA 70, or the Canadian Electrical Code, CSA C22.1, and such local regulations as might apply. It is the customer's responsibility to have the wiring and fuses installed by a qualified electrician to make sure adequate electrical power is available to the dryer.</p>	
W521	

When plugging in the dryer:

- Do not overload circuits.
- Do not use an adapter.
- Do not use an extension cord.
- Do not operate both a washer and gas dryer on the same circuit. Use separately fused 15 amp circuits.

The dryer is designed to be operated on a separate branch, polarized, three-wire, effectively grounded, 120 Volt, 60 Hertz, AC (alternating current) circuit protected by a **15 Ampere fuse**, equivalent fusetrone or circuit breaker.

The three-prong grounding plug on the power cord should be plugged directly into a polarized three-slot effectively grounded receptacle rated 120 Volts AC (alternating current) 15 Amps. Refer to *Figure 30* to determine correct polarity of the wall receptacle.

Grounding Information

The dryer must be grounded. In the event of malfunction or breakdown, grounding will reduce the risk of electric shock by providing a path of least resistance for electric current. The dryer is equipped with a cord having an equipment-grounding conductor and a 3 prong grounding plug. The three-prong grounding plug on the power cord should be plugged directly into a polarized three-slot effectively grounded receptacle rated 110/120 Volts AC (alternating current) 15 Amps.

	WARNING
<p>This dryer is equipped with a three-prong (grounding) plug for your protection against shock hazard and should be plugged directly into a properly grounded three-prong receptacle. Do not cut or remove the grounding prong from this plug.</p>	
<small>W036</small>	

	WARNING
<p>Improper connection of the equipment-grounding conductor can result in a risk of electric shock. Check with a qualified electrician or service person if you are in doubt as to whether the dryer is properly grounded.</p>	
<small>W038</small>	

Do not modify the plug provided with the dryer – if it will not fit the outlet, have a proper outlet installed by a qualified electrician.

NOTE: Have a qualified electrician check the polarity of the wall receptacle. If a voltage reading is measured other than that illustrated, the qualified electrician should correct the problem.

Do not operate other appliances on the same circuit when this appliance is operating.

	WARNING
<p>To reduce the risk of an electric shock or fire, DO NOT use an extension cord or an adapter to connect the dryer to the electrical power source.</p>	
<small>W037</small>	

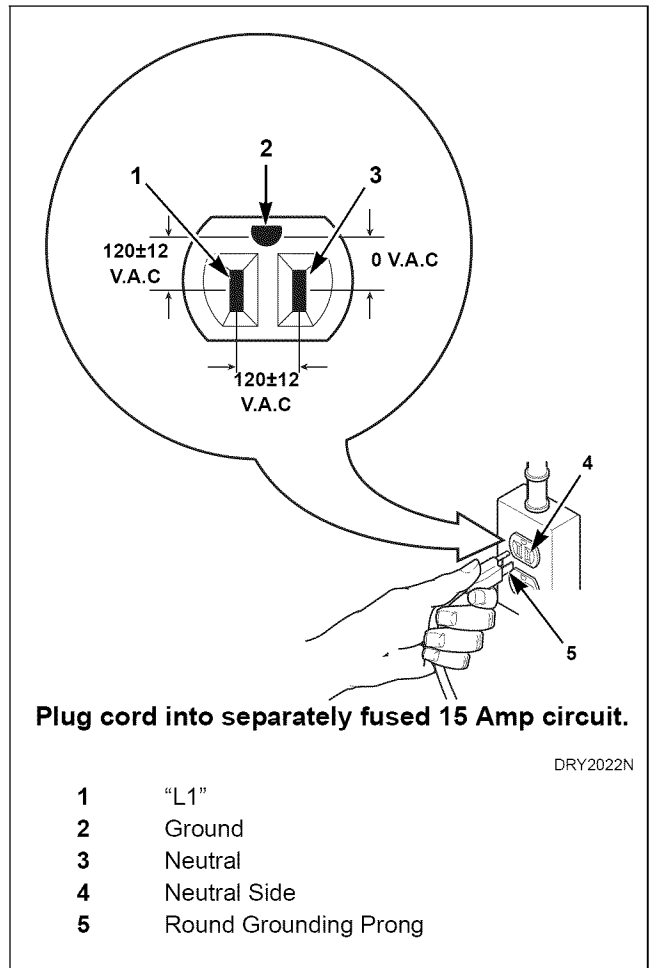

Figure 30

Washer

Washer requires 120 Volt, 60 Hertz electrical supply and comes equipped with a 3-prong grounding plug. Refer to serial plate for specific electrical requirements.

NOTE: The wiring diagram is located behind the control panel, inside the control cabinet.

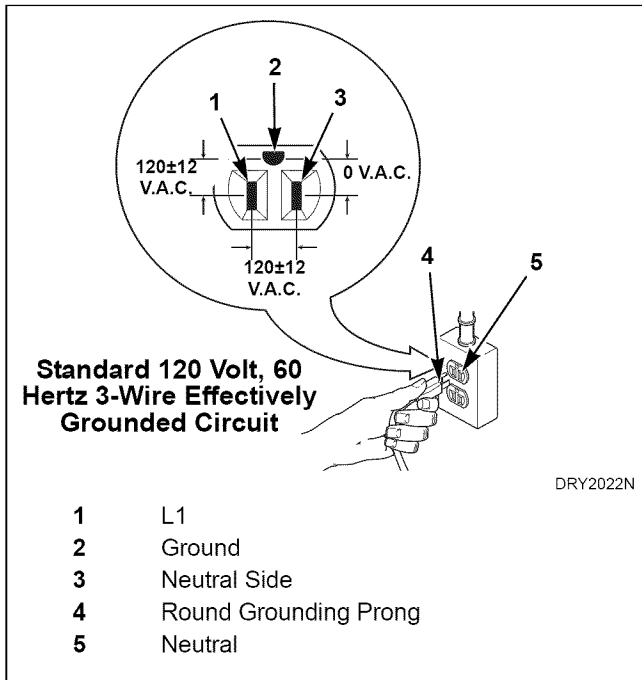

Figure 31

	WARNING
<p>To reduce the risk of fire, electric shock, serious injury or death, all wiring and grounding MUST conform with the latest edition of the National Electrical Code, ANSI/NFPA No. 70, and such local regulations as might apply. It is the customer's responsibility to have the wiring, fuses and circuit breakers installed by a qualified electrician to make sure adequate electrical power is available to the washer.</p>	
W518	

When plugging in the washer:

- DO NOT overload circuits.
- DO NOT use an extension cord.
- DO NOT use an adapter.
- DO NOT operate both a washer and gas dryer on the same circuit. Use separately fused 15 Amp circuits.

The washer is designed to be operated on a separate branch, polarized, three-wire, effectively grounded, 120 Volt, 60 Hertz, AC (alternating current) circuit protected by a **15 Amp fuse**, equivalent fusetrone or circuit breaker.

The three-prong grounding plug on the power cord should be plugged directly into a polarized three-slot effectively grounded receptacle rated 110/120 Volts AC (alternating current) 15 Amps. Refer to *Figure 31* to determine correct polarity of the wall receptacle.

	WARNING
<p>To reduce the risk of an electric shock or fire, DO NOT use an extension cord or an adapter to connect the washer to the electric power source.</p>	
W082	

Grounding Information

The washer must be grounded. In the event of malfunction or breakdown, grounding will reduce the risk of electric shock by providing a path of least resistance for electric current.

The washer is equipped with a cord having an equipment-grounding conductor and a 3-prong grounding plug. The plug must be plugged into an appropriate outlet that is properly installed and grounded in accordance with all local codes and ordinances.

	WARNING
Improper connection of the equipment-grounding conductor can result in a risk of electric shock. Check with a qualified electrician or service person if you are in doubt as to whether the washer is properly grounded.	
W216	

Do not modify the plug provided with the washer – if it will not fit the outlet, have a proper outlet installed by a qualified electrician.

NOTE: Have a qualified electrician check the polarity of the wall receptacle. If a voltage reading is measured other than that in *Figure 31*, the qualified electrician should correct the problem.

	WARNING
This unit is equipped with a three-prong (grounding) plug for your protection against shock hazard and should be plugged directly into a properly grounded three-prong receptacle. Do not cut or remove the grounding prong from this plug.	
W213	

Step 11: Recheck steps 1-10

Refer to *Installer Checklist* on the back cover of this manual and make sure that unit is installed correctly.

Run the washer with a test load to make sure it is operating properly and is properly leveled.

1. Put about six pounds of laundry (four bath towels and three jeans) into washer.
2. Close door.
3. Select a Spin Only cycle and press Start.
4. When washer spins at high speed, verify that it is stable.
5. If it is not, after cycle is complete, refer to Step 2 and readjust leveling legs.

Step 12: Check Heat Source

Electric Dryers

Close the loading door and start the dryer in a heat setting (refer to the Dryer User's Guide supplied with the unit). After the dryer has operated for three minutes, the exhaust air or exhaust pipe should be warm.

Gas Dryers

IMPORTANT: This operation is to be conducted by qualified personnel only.

To view the burner flame, remove the lower front panel of the dryer.

Close the loading door, start the dryer in a heat setting (refer to the Dryer User's Guide supplied with the unit); the unit will start, the igniter will glow red and the main burner will ignite.

IMPORTANT: If all air is not purged out of gas line, gas igniter may go off before gas is ignited. If this happens, after approximately two minutes igniter will again attempt gas ignition.

IMPORTANT: If igniter does not light, make sure gas is turned on.

After the dryer has operated for approximately five minutes, observe burner flame through lower front panel. Adjust the air shutter to obtain a soft, uniform blue flame. (A lazy, yellow-tipped flame indicates lack of air. A harsh, roaring, very blue flame indicates too much air.) Adjust the air shutter as follows:

1. Loosen the air shutter lock screw.
2. Turn the air shutter to the left to get a luminous yellow-tipped flame, then turn it back slowly to the right to obtain a steady, soft blue flame.
3. After the air shutter is adjusted for proper flame, tighten the air shutter lock screw securely.
4. Reinstall the lower front panel.



WARNING

For personal safety, lower front panel must be in place during normal operation.

W046

After the dryer has operated for approximately three minutes, exhaust air or exhaust pipe should be warm.

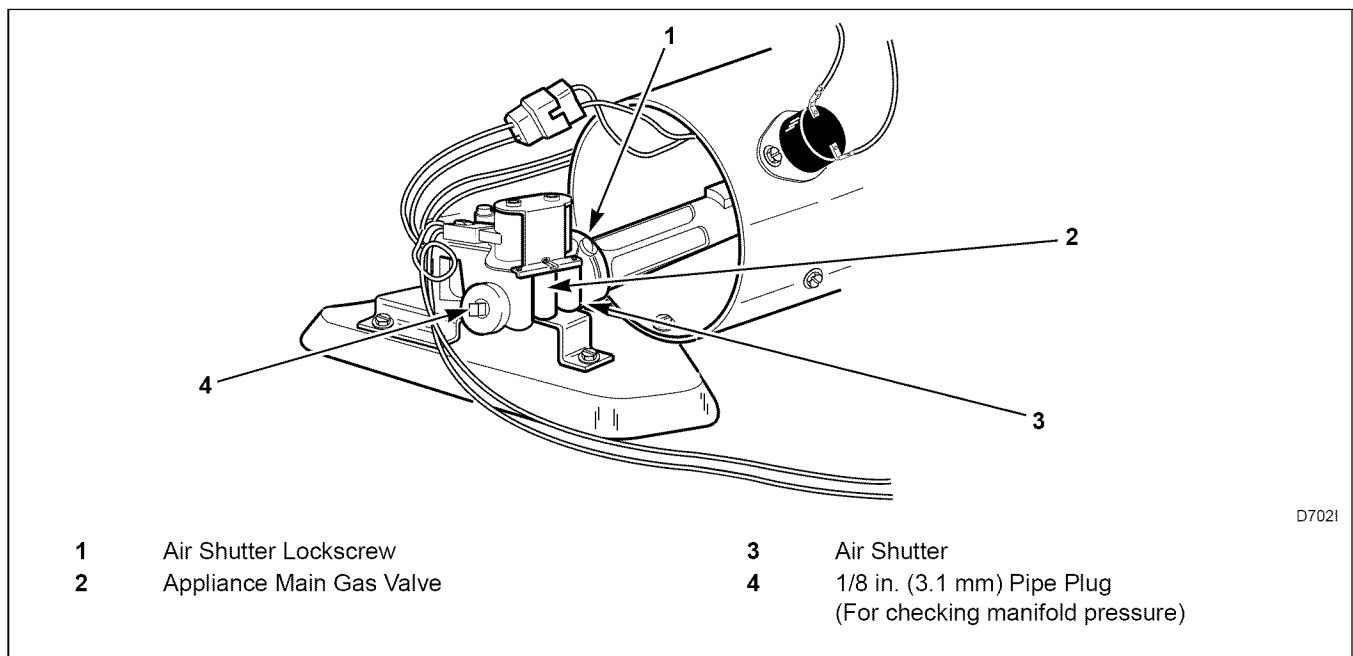

Figure 32

Installer Checklist

Fast Track for Installing the Unit

(Refer to the manual for more detailed information)

- 1** • Position Unit Near Installation Area.

CHECK

- 2** • Position and Level the Unit.

CHECK

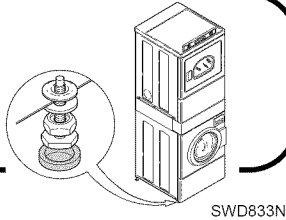

- 3** • Connect Fill Hoses.

CHECK

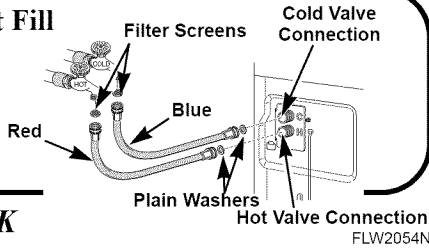

- 4** • Connect Drain Hose to Drain Receptacle.

CHECK

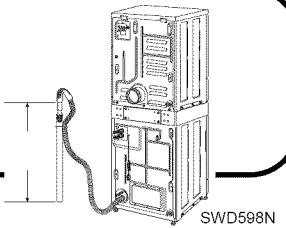

- 5 Gas Only**
- Connect Gas Supply Pipe.
 - Check for Gas Leaks.

CHECK

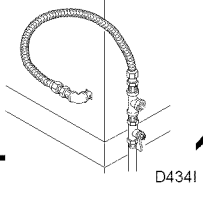

- 6 Electric Only**
- Connect Electrical Cords.

CHECK

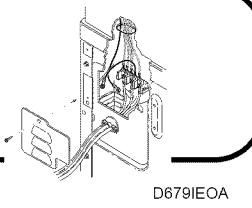

- 7** • Connect Dryer Exhaust System.

CHECK

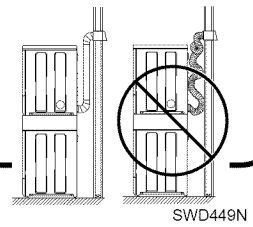

- 8 Washer Only**
- Remove the Shock Sleeves and Shipping Brace.

CHECK

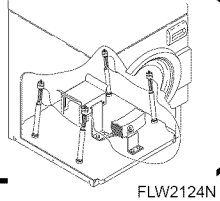

- 9** • Wipe Out Inside of Washer and Dryer.

CHECK

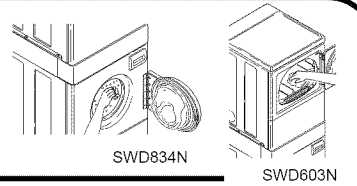

- 10** • Plug In Washer and Dryer.

CHECK



- 11** • Recheck Steps 1-10.

CHECK

- 12** • Check Heat Source.

CHECK

