

Operator's Manual

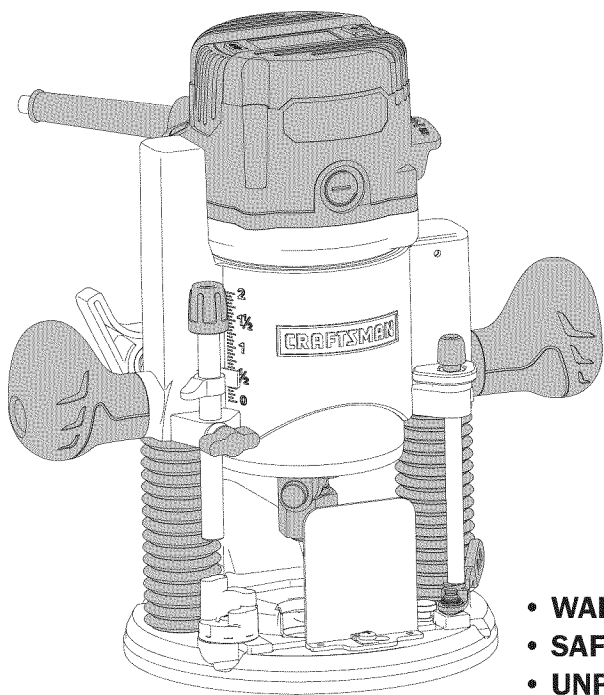

12.0 Amp, Variable Speed, 2 Peak HP Digital Plunge Base Router

Model No. 320.27669



⚠ WARNING: To reduce the risk of injury, the user must read and understand the Operator's manual before using this product.

- WARRANTY
- SAFETY
- UNPACKING
- DESCRIPTION
- OPERATION
- MAINTENANCE
- TROUBLESHOOTING
- ESPAÑOL

Sears Brands Management Corporation, Hoffman Estates, IL 60179 U.S.A.

www.craftsman.com

TABLE OF CONTENTS

Warranty	page 2
Safety Symbols	page 3-4
Safety Instructions	page 5-10
Unpacking	Page 10-11
Description	page 12-14
Operation	page 15-31
Maintenance	page 32-33
Troubleshooting	page 34-36
Exploded View and Part List	page 37-43
Sears Repair Parts Phone Number	Back Cover

CRAFTSMAN ONE YEAR LIMITED WARRANTY

FOR ONE YEAR from the date of purchase, this product is warranted against any defects in material or workmanship. With proof of purchase, defective product will be replaced free of charge.

For warranty coverage details to obtain free replacement, visit the web site: www.craftsman.com

This warranty is void if this product is ever used while providing commercial services or if rented to another person.

This warranty gives you specific legal rights, and you may also have other rights which vary from state to state.

Sears Brands Management Corporation, Hoffman Estates, IL 60179

 **WARNING:** Some dust created by using power tools contains chemicals known to the state of California to cause cancer and birth defects or other reproductive harm.

SAVE THESE INSTRUCTIONS!

READ ALL INSTRUCTIONS!

This router has many features for making its use more pleasant and enjoyable. Safety, performance, and dependability have been given top priority in the design of this product making it easy to maintain and operate.

SAFETY SYMBOLS

The purpose of safety symbols is to attract your attention to possible dangers. The safety symbols and the explanations with them deserve your careful attention and understanding. The symbol warnings do not, by themselves, eliminate any danger. The instructions and warnings they give are no substitutes for proper accident prevention measures.

▲ WARNING: Be sure to read and understand all safety instructions in this manual, including all safety alert symbols such as “**DANGER**,” “**WARNING**,” and “**CAUTION**,” before using this router. Failure to follow all instructions listed in this manual may result in electric shock, fire and/or serious personal injury.

SYMBOL SIGNAL MEANING

▲ SAFETY ALERT SYMBOL: Indicates **DANGER, WARNING, OR CAUTION**. May be used in conjunction with other symbols or pictographs

▲ DANGER: Indicates a hazardous situation which, if not avoided, will result in death or serious injury. This signal word is to be limited to the most extreme situations. Always follow the safety precautions to reduce the risk of fire, electric shock, and personal injury.

▲ WARNING: Indicates a hazardous situation which, if not avoided, could result in death or serious injury. Always follow the safety precautions to reduce the risk of fire, electric shock, and personal injury.

▲ CAUTION: Indicates a hazardous situation which, if not avoided, could result in minor or moderate injury. It may also be used without the safety alert symbol as an alternative to “NOTICE”² Always follow the safety precautions to reduce the risk of fire, electric shock, and personal injury.

NOTICE: “NOTICE” is the preferred signal word to address practices not related to personal injury. The safety alert symbol not be used with this signal word. As an alternative to “NOTICE”, the word “CAUTION” without the safety alert symbol may be used to indicate a message not related to personal injury.²

Damage Prevention and Information Messages

These inform the user of important information and/or instructions that could lead to equipment or other property damage if they are not followed. Each message is preceded by the word “NOTE,” as in the example below:

NOTE: Equipment and/or property damage may result if these instructions are not followed.

▲ WARNING: To ensure safety and reliability, all repairs should be performed at a Sears Parts & Repair Service Center.







▲ WARNING: The operation of any power tools can result in foreign objects being thrown into your eyes, which can result in severe eye damage. Before beginning power tool operation, always wear safety goggles or safety glasses with side shield and a full face shield when needed. We recommend a Wide Vision Safety Mask for use over eyeglasses or standard safety glasses with side shields. Always use eye protection which is

marked to comply with ANSI Z87.1

SAVE THESE INSTRUCTIONS

Some of the following symbols may be used on this tool. Please study them and learn their meaning. Proper interpretation of these symbols will allow you to operate the tool better and more safely.

SYMBOL	NAME	DESIGNATION/EXPLANATION
V	Volts	Voltage
A	Amperes	Current
Hz	Hertz	Frequency (cycles per second)
W	Watt	Power
min	Minutes	Time
	Alternating Current	Type of current
	Direct Current	Type or a characteristic of current
n_0	No Load Speed	Rotational speed, at no load
	Class II Construction	Double-insulated construction
.../min	Per Minute	Revolutions, strokes, surface speed, orbits, etc., per minute
	Wet Conditions Alert	Do not expose to rain or use in damp locations.
	Read The Operator's Manual	To reduce the risk of injury, user must read and understand operator's manual before using this product.
	Eye Protection	Always wear safety goggles or safety glasses with side shields and a full face shield when operating this product.
	Safety Alert	Precautions that involve your safety.
	No Hands Symbol	Failure to keep your hands away from the blade will result in serious personal injury.
	No Hands Symbol	Failure to keep your hands away from the blade will result in serious personal injury.
	No Hands Symbol	Failure to keep your hands away from the blade will result in serious personal injury.
	No Hands Symbol	Failure to keep your hands away from the blade will result in serious personal injury.
	Hot Surface	To reduce the risk of injury or damage, avoid contact with any hot surface.

SAFETY INSTRUCTIONS

GENERAL POWER TOOL SAFETY WARNINGS

⚠ WARNING: Read all safety warnings and instructions. Failure to follow the warnings and instructions may result in electric shock, fire and/or serious injury.

- **Know your power tool. Read the operator's manual carefully.** Learn the applications, as well as the specific potential hazards related to this tool. Following this rule will reduce the risk of electric shock, fire or serious injury.
- **Save these instructions.** Refer to them frequently and use them to instruct others who may use this tool. If someone borrows this tool, make sure they have these instructions also.
- **The term "power tool" in the warnings refers to your mains-operated (corded) power tool or battery-operated (cordless) power tool.**

WORK AREA SAFETY

- **Keep the work area clean and well lit.** Cluttered or dark areas invite accidents.
- **Do not operate power tools in explosive atmospheres, such as in the presence of flammable liquids, gases or dust.** Power tools create sparks which may ignite the dust or fumes.
- **Keep children and bystanders away while operating a power tool.** Distractions can cause you to lose control.

ELECTRICAL SAFETY

- **Power tool plugs must match the outlet. Never modify the plug in any way. Do not use any adapter plugs with earthed (grounded) power tools.** Unmodified plugs and matching outlets will reduce risk of electric shock
- **Avoid body contact with earthed or grounded surfaces such as pipes, radiators, ranges and refrigerators.** There is an increased risk of electric shock if your body is earthed or grounded.
- **Do not expose power tools to rain or wet conditions.** Water entering a power tool will increase the risk of electric shock.
- **Inspect the tool cords periodically and, if damaged, have them repaired at your nearest Sears Service Center.** Be aware of the cord location.
- **Do not abuse the cord. Never use the cord for carrying, pulling or unplugging the power tool. Keep the cord away from heat, oil, sharp edges or moving parts.** Damaged or entangled cords increase the risk of electric shock.
- **When operating a power tool outdoors, use an extension cord suitable for outdoor use.** Use of a cord suitable for outdoor use reduces the risk of electric shock.

- **If operating a power tool in a damp location is unavoidable, use a ground fault circuit interrupter (GFCI) protected supply.** Use of a GFCI reduces the risk of electric shock.

PERSONAL SAFETY

- **Stay alert, watch what you are doing and use common sense when operating a power tool. Do not use the tool while tired or under the influence of drugs, alcohol, or medication.** A moment of inattention while operating power tools may result in serious personal injury.
- **Know your power tool. Read the operator's manual carefully.** Learn the applications, as well as the specific potential hazards related to this tool. Following this rule will reduce the risk of electric shock, fire or serious injury.
- **Always wear safety glasses or eye shields when using this router.** Everyday eyeglasses have only impact-resistant lenses; they are not safety glasses.
- **Protect your lungs.** Wear a face mask or dust mask if the operation is dusty.
- **Protect your hearing.** Wear appropriate personal hearing protection during use. Under some conditions noise from this product may contribute to hearing loss.
- **All visitors and bystanders must** wear the same safety equipment that the operator of the router wears.
- **Prevent unintentional starting.** Ensure that the switch is in the OFF-position before connecting to a power source and/or battery, picking up or carrying the tool. Carrying power tools with your finger on the switch or energizing power tools that have the switch on invites accidents.
- **Remove any adjusting key or wrench before turning the power tool on.** A wrench or a key left attached to a rotating part of the power tool may result in personal injury.
- **Do not overreach. Keep proper footing and balance at all times.** This enables better control of the power tool in unexpected situations.
- **Dress properly. Do not wear loose clothing or jewelry. Keep your hair, clothing and gloves away from moving parts.** Loose clothes, jewelry or long hair can be caught in moving parts.
- **If devices are provided for the connection of dust extraction and collection facilities, ensure that these are connected and properly used.** Use of these devices can reduce dust-related hazards.

POWER TOOL USE AND CARE

- **Do not force the power tool. Use the correct power tool for your application.** The correct power tool will do the job better and more safely at the rate for which it was designed.

- **Do not use the power tool if the switch does not turn it on and off.** Any power tool that cannot be controlled with the switch is dangerous and must be repaired.
- **Always check the tool for damaged parts before use.** Before further use of the tool, a guard or other part that is damaged should be carefully checked to determine if it will operate properly and perform its intended function. Check for misalignment or binding of moving parts, breakage of parts, and any other condition that may affect the tool's operation. A guard or other part that is damaged should be properly repaired or replaced at a Sears Service Center.
- **Disconnect the plug from the power source and/or the battery from the power tool before making any adjustments, changing accessories, or storing power tools.** Such preventive safety measures reduce the risk of starting the power tool accidentally.
- **Store idle power tools out of the reach of children and do not allow persons unfamiliar with the power tool or these instructions to operate the power tool.** Power tools are dangerous in the hands of untrained users.
- **Maintain power tools. Check for misalignment or binding of moving parts, breakage of parts and any other condition that may affect the power tool operation. If damaged, have the power tool repaired before use.** Many accidents are caused by poorly maintained power tools.
- **Keep cutting tools sharp and clean.** Properly maintained cutting tools with sharp cutting edges are less likely to bind and are easier to control.
- **Use the power tool, accessories, tool bits, etc., in accordance with these instructions, taking into account the working conditions and the work to be performed.** Use of the power tool for operations different from those intended could result in a hazardous situation.

 **WARNING:** When using power tools, basic safety precautions should always be followed to reduce the risk of fire, electric shock, and personal injury.

 **WARNING:** The operation of any tool can result in foreign objects being propelled into your eyes, resulting in severe eye damage. When operating power tool, always wear safety goggles or safety glasses with side shields and a full face shield when needed.

 **WARNING:** If any parts are missing, do not operate the tool until the missing parts have been replaced. Doing so could result in serious personal injury.

SERVICE SAFETY

- **Have your power tool serviced by a qualified repair person using only identical replacement parts.** This will ensure that the safety of the power tool is maintained.

- **If any part of this router is missing or should break, bend,** or fail in any way; or should any electrical component fail to perform properly: shut off the power switch and remove the plug from the power source and have the missing, damaged, or failed parts replaced before resuming operation.
- **Tool service** must be performed only at a Sears Parts & Repair Service Center. Service or maintenance performed by unqualified personnel could result in a risk of injury.
- **Use only identical replacement parts** when servicing a tool. Follow the instructions in the maintenance section of this manual. Use of unauthorized parts or failure to follow maintenance instructions may create a risk of electric shock or injury.

SPECIFIC SAFETY RULES FOR ROUTER

- **Hold power tools by insulated gripping surfaces** when performing an operation where the cutting tool may contact hidden wiring or its own cord. Contact with a “live” wire will make exposed metal parts of the tool “live” and shock the operator.
- **Use clamps or another practical way to support and secure the workpiece to a stable platform.** Holding the work by hand or against your body leaves it unstable and may lead to loss of control.
- **Maintain a firm grip** on the router with both hands to resist starting torque.
- **Never attempt to use the router motor without first installing it in an approved fixed base.** Failure to heed this warning could result in personal injury and damage to the motor.
- **Make sure that the motor housing does not move up or down when clamped in the fixed base.** If the motor is not securely clamped into the base, injury could result and adjustments will not be accurate.
- **Do not hand-hold the router in an upside down or horizontal position.** The motor can separate from the base if not properly attached according to the instructions.
- **Tighten the collet/nut securely to prevent the cutter bit from slipping.** If the collet/nut is not securely tightened, the cutter bit may detach during use, causing serious personal injury.
- **Never tighten collet/nut without a cutter bit installed in the collet/nut.**
- **Never hold the piece being cut in your hands or across your legs.** It is important to support and clamp the workpiece properly in order to minimize body exposure, bit binding, or loss of control.
- **Always keep the chip shield clean and in place.**
- **Stay alert and clear the router cutter bit path of any obstructions before starting the motor.** Keep cutting area clear of all foreign objects while the motor is running.

- **Inspect and remove all nails from lumber before routing.**
- **Check to see that the cord will not “hang up” during routing operation.**
- **Make sure that the cutter bit is not in contact with the workpiece before the switch is turned on.** The bit must always be running at full speed before contacting the workpiece.
- **Keep hands clear** of the cutter bit when the motor is running to prevent personal injury.
- **Provide clearance under the workpiece** for the router cutter bit when through-cutting.
- **Keep cutting pressure constant.** Do not overload the motor.
- **Use only sharp cutter bits** that are not chipped or cracked. Blunt cutter bits will cause stalling and burn the workpiece.
- **Never use this router motor with a cutter bit larger than 3-1/2 inches in diameter.**
- **Always use cutter bits that are designed for this router. Never use cutter bits which are larger in diameter than the opening in the router sub-base.** Cutter bits that have cutter diameters larger than the opening could cause possible loss of control or create other hazardous condition that could cause serious personal injury.
- **The sub-base on this fixed base router has an opening of 1-1/4 inches.** To use cutter bits with a larger diameter, install and use a sub-base with a larger diameter opening (sold separately at Sears stores or other Craftsman outlets).
- **Do not use large router cutter bits for freehand routing.** Use of large cutter bits when freehand routing could cause loss of control or create hazardous conditions that could result in serious personal injury. If using a router table, large bits should be used for edging only.
- **Be sure that the cutter bit is centered in a template guide** (sold separately) prior to template guide applications to avoid personal injury or damage to finished work.
- **Do not remove more than 1/8 inch in a single pass.** Excessive depth of cut can result in loss of control that could result in personal injury.
- **After completing a cut, turn the motor OFF and let it come to complete stop before removing router from workpiece.**
- **Let the motor come to a complete stop before putting the router down.** Cutter bits coast after the power is turned off.
- **Only use router tables with on-board switch-controlled receptacles.** Failure to use router tables with all the appropriate safety features could result in serious personal injury.

- **Disconnect the tool from the power source** before making any adjustments or changing cutter bits.
- **If you are changing a bit immediately after use, be careful not to touch the collet/nut or cutter bit with your hands or fingers.** The heat buildup from cutting could cause severe burns. Always use the wrench provided.
- **Avoid “climb cutting;” see “OPERATION” section in this manual.** “Climb cutting” increases the chance for loss of control resulting in possible serious injury.

UNPACKING





⚠ WARNING: Your router should never be connected to the power source when you are assembling parts, making adjustments, installing or removing bits, cleaning, or when it is not in use. Disconnecting the router will prevent accidental starting, which could cause serious personal injury.

When unpacking the box, do not discard any packing materials until all of the contents are accounted for:

1. Carefully lift the router out of carton and place it on a stable, flat surface.
2. Open the carton to locate the following:
 - Vacuum port and 2 screws used to attach it to the base
 - Chip shield (already installed on router)
 - 1/4 inch .collets/nut (the 1/2 in. collet/nut is already installed on router)
 - Collet/nut wrench
 - Depth-Adjustment Wrench
 - Edge Guide
 - Manual
3. Inspect the items carefully to make sure that no breakage or damage has occurred during shipping. If any of the items mentioned is missing, (refer to “PARTS LIST” illustration), return the router to your nearest Sears store to have the router replaced.

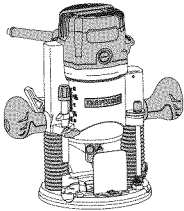
⚠ WARNING: If any part is broken or missing, do not attempt to assemble the router, plug in the power cord, or operate the router until the broken or missing part is replaced. Failure to do so could result in possible serious injury.

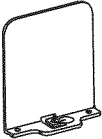
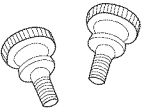
CARTON CONTENTS/LOOSE PARTS (Fig.1)

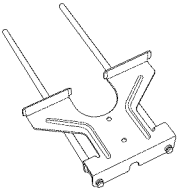
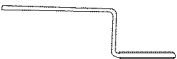
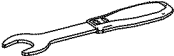
	Plunge Base and Digital Router motor with 1/2 inch Collet/ Nut
	Vacuum Port
	Chip shield (already installed on router)
	2 screws (for attaching vacuum port)
	1/4 inch Collet/Nut
	Edge guide
	Depth-adjustment wrench
	Collet/Nut wrench

DESCRIPTION

KNOW YOUR DIGITAL ROUTER (Fig. 2)

NOTE: Before attempting to use your router, familiarize yourself with all of the operating features and safety requirements.

Your plunge base router has a precision-built electric motor and it should only be connected to a 120-volt, 60-Hz AC only power supply (normal household current). Do not operate on direct current (DC). This large voltage drop will cause a loss of power and the motor will overheat. If the router does not operate when plugged into a correct 120-volt, 60-Hz AC only outlet, check the power supply. This router has an 8-ft., 2-wire power cord (no adapter needed).

Fig. 2

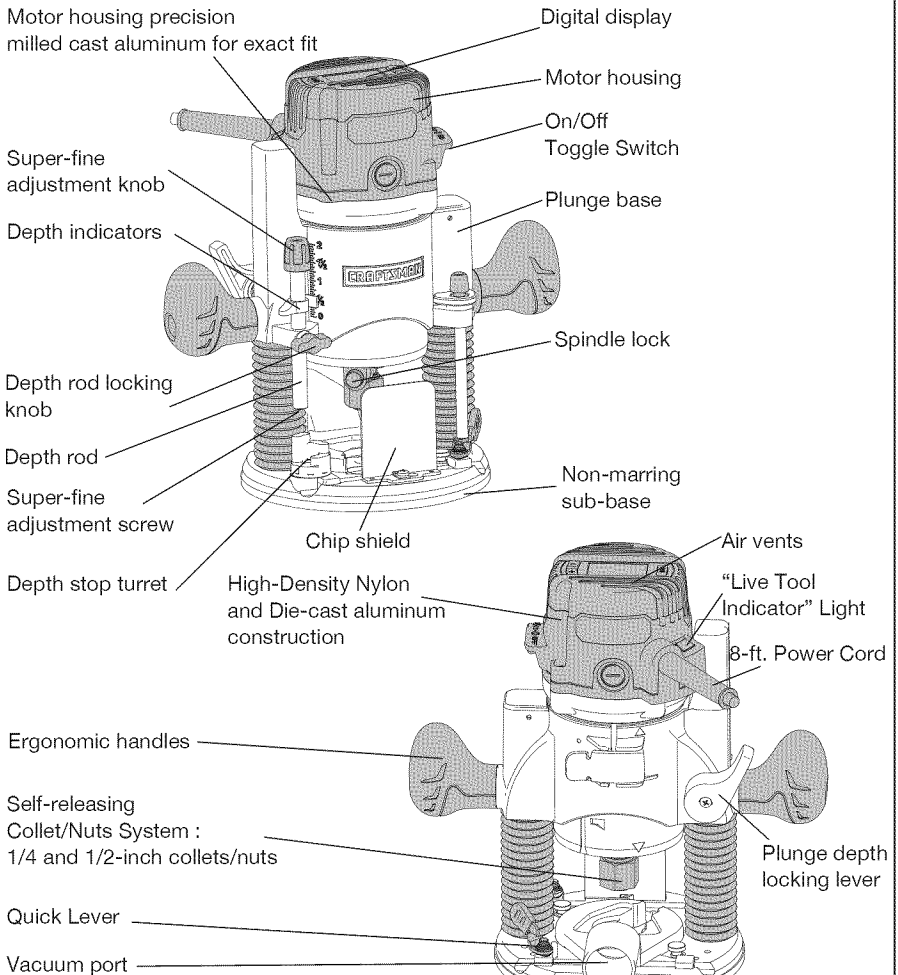

⚠ WARNING: Do not allow familiarity with the router to cause a lack of alertness. A fraction of a second of carelessness is enough to cause severe injury

PRODUCT SPECIFICATIONS	
Rating	12 .0Amps
No Load Speed	10000-25000 RPM
Peak HP	2
Input	120-volt, 60Hz AC
Collets/Nuts and Cutter bit Shank Diameters	1/4 in. and 1/2 in.
Plunge Base Diameter	6-11/16"
Sub Base Opening (Diameter for cutter bit use)	1-1/4 inches
Sub Base Thickness	0.23 inch (6mm)
Plunge Base Depth of Cut	2-1/8 inches (55mm)

⚠ WARNING: The safe use of this product requires an understanding of the information on the tool and in this operator's manual, as well as knowledge of the project you are attempting. Before use of this product, familiarize yourself with all operating features and safety rules.

This Plunge Router has the following features:

1. Powerful, **12.0 Amp soft start motor** develops **2 Peak HP** to handle most routing jobs.
2. **Electronic Feedback Circuitry** provides soft starts for longer motor life, and maintains constant speed under load to help produce a quality finish in all materials.
3. **Variable-Speed Motor** runs at **10,000 to 25,000 RPM** (no-load speed).
4. **Variable-Speed** allows matching proper speed to material and cutter bit size.
5. **Quick-clamp System** allows motor to be changed from fixed to plunge base without use of tools.
6. Plunge Base features **Fine and Micro Depth Rod Adjustments with Turret Stops** for precise set-ups and repetitive cutting.
7. Smooth **Plunge Action** lowers bit into workpiece at 90° for more accurate cutting.
8. Protective **Plunge Post Bellows** protect guideposts from woodchips, dust, and moisture.

9. **Spindle Lock** for easy 1 wrench bit changes. Includes 1/4 and 1/2 inch **Self-Releasing** Collets/Nuts for use with a wide variety of 1/4 in. and 1/2 in. router bits, sold separately.
10. 100% **Ball Bearings** for smooth, efficient operation and long life.
11. Base Features **Large Base Openings** and **Large Chip Shield**, combined with **3 LED Worklights** on motor to provide high visibility of bit and workpiece.
12. **Durable Non-marring Sub-base** glides smoothly over workpiece. The sub-base installed on this router has an opening of 1-1/4 inches. To use cutter bits with larger diameters, please disassembly vacuum port and use sub-bases with larger openings, sold separately at Sears stores or other Craftsman outlets.
13. **Motor Housing** constructed of **High Density Nylon** and **Precision Milled Cast Aluminum** for strength and exact fit into bases.
14. High-impact resistant **Motor Housing Top Cap** and Handles on Bases help protect tool from damage.
15. Conveniently located **ON/OFF toggle switch**, side mounted for added visibility, easy access.
16. **Vacuum Port** allows base to attach to 1-1/4 inches vac hose attachment, sold separately.
17. **Large 1" X1-1/2" LCD Screen** provides digital readings of motor speed and suggests bits selection
18. "**Live Tool Indicator**" light is green when router is plugged into a power source. Light is located on motor housing top cap next to power cord inlet.
19. **Replaceable Brushes** (sold separately) for dependable service.
20. Includes carry bag for easy carrying and storage.

OPERATION

NOTE: This tool is shipped completely assembled. To change the router motor from one base to another, install or remove cutter bits or add accessories such as vacuum ports for hook-up to vacs, see the following instructions.

SELECTING THE CUTTER BIT

This router comes with 1/4 in. and 1/2 in. collets/nuts that accept 1/4 inch and 1/2 inch shanks.

⚠ WARNING: The sub-base installed on this router has an opening of 1-1/4 inches. To use cutter bits with larger diameters, please disassembly vaccum port and use sub-bases with larger openings, sold separately at Sears stores or other Craftsman outlets.

⚠ WARNING: Always turn the motor off and unplug the router before making any adjustments or installing accessories. Failure to unplug the router could result in accidental starting, which can cause serious personal injury.

INSTALLING AND REMOVING THE CUTTER BIT

INSTALLING THE CUTTER BIT

1. Turn motor off and unplug from power source.
2. Remove motor housing from the plunge base.

NOTE: See the instructions for installing and removing on the motor housing from the plunge base.

3. Set the motor upside down on its top cap, with collet/nut pointing up.
4. Press the spindle-lock button to engage and lock the spindle shaft and collet/nut. (Fig. 3)
5. Place the wrench on the collet/nut and turn it counterclockwise to loosen the collet/nut slightly so it can accept cutter bit shank.
6. Insert the cutter bit shank into the collet/nut assembly as far as it will go, then back the shank out until the cutters are approximately 1/8 to 1/4 inch away from the face of the collet/nut. (Fig. 4, 4a)

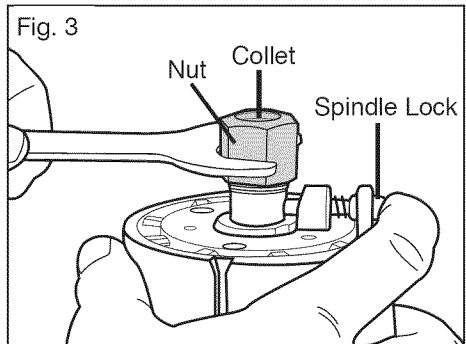

NOTE: To ensure proper gripping of the cutter bit shank and minimize run-out, the shank of the cutter bit must be inserted into the collet/nut at least 5/8 inch.

7. With the cutter bit inserted and spindle-lock button pressed in engaging shaft, place the wrench on collet/nut and turn clockwise until the collet/nut is firmly tightened on the cutter bit shank.

▲ WARNING: Tighten the collet/nut securely to prevent the cutter bit from slipping. If the collet/nut is not securely tightened, the cutter bit may detach during use, causing serious personal injury.

NOTE: To prevent damage to tool, do not tighten the collet/nut without a cutter bit installed.

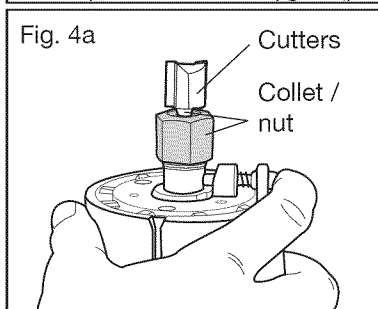
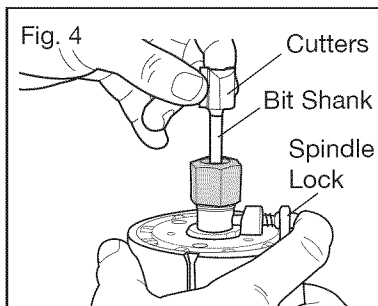

REMOVING THE CUTTER BIT

1. Turn the motor off and unplug the router from the power source.
2. Remove the motor from the fixed base.

NOTE: See the instructions for installing and removing the motor housing from the plunge base.

3. Set the motor upside down on its top cap, with collet/nut pointing up.
4. Press the spindle-lock button to engage and lock the spindle shaft and the collet/nut. (Fig. 3)
5. Place the wrench on the collet/nut and turn counterclockwise to loosen the collet/nut slightly.
6. Remove cutter bit shank.

NOTE: The collet/nut is self-releasing; it is necessary to strike the collet/nut to free the router cutting bit. If the cutter bit seems stuck after use, loosen the collet/nut a little more until it releases.

COLLET/NUT CARE

Before each use, inspect the collet/nut to make sure that it is clean and that it is gripping the cutter bit properly.

With the router cutter bit removed, turn the collet/nut counterclockwise (with spindle-lock engaged) until it is free from the motor's spindle shaft.

Blow the collet out with compressed air, and clean the tapered inside of the collet/nut with a tissue or a fine brush.

▲ WARNING: Always wear safety goggles or safety glasses with side shields during power tool operations, or when blowing dust. If operation is dusty, also wear a dust mask.

Always make sure that the cutter bit shank, collet/nut and motor spindle are clean and free of woodchips, dust, residue, grease and rust before installing a cutter bit or collet/nut.

Apply a slight amount of machine oil to the spindle shaft if it looks dry.

Replace a worn or damaged collet/nut immediately.

NOTE: The collet/nut is self-releasing; it is not necessary to strike the collet/nut to free the router cutter bit. If the cutter bit seems to be stuck after use, loosen the collet/nut a little more until it releases.

CUTTER BITS

Keep cutter bits clean and sharp only the inside of the cutting edge for faster, more accurate cutting results. Remove all accumulated pitch and gum from cutter bits after each use.

When sharpening cutter bits, sharpen only the inside of the cutting edge. Never grind the outside diameter. Be sure, when sharpening the end of a cutter bit, to grind so that the clearance angle the same as originally ground.

INSTALLING THE ROUTER MOTOR IN THE BASE (Fig. 5)

WARNING: Never use the router motor without installing it into either an approved fixed or plunge base. Failure to do so could result in serious personal injury and damage to motor.

▲ WARNING: Always turn the motor off and unplug the router from the power source before making any adjustments or installing accessories. Failure to turn the motor off and unplug the router could result in accidental starting, which can cause serious personal injury.

1. Turn the motor off and unplug the router from the power source.
2. Place the plunge base on a flat surface.
3. With the back of the plunge base facing you, open the motor clamp (A) and make sure the plunge action is in “UP” position, with the plunge lock lever (B) be locked down.
4. With the motor housing pin (C) aligned with the plunge base slot (D), lower the motor housing into the plunge base engaging the pin into the slot.

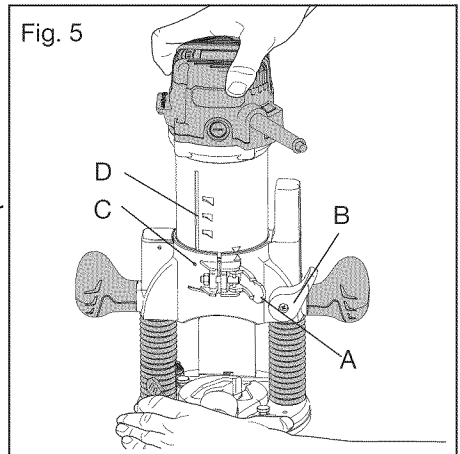

5. Slide the motor into the base as far as it will go.
6. Close the motor clamp securely.

NOTE: When making depth adjustments on the plunge base, the motor clamp should always be closed securely.

REMOVING THE MOTOR FROM THE BASE (Fig. 5)

▲ WARNING: Always turn the motor off and unplug the router from the power source before making any adjustments or installing accessories. Failure to turn the motor off and unplug the router could result in accidental starting, which can cause serious personal injury.

1. Turn the motor off and unplug the router from the power source.
2. Place the router (plunge base and motor housing) on a flat surface.
3. With the back of the plunge base facing you, open the motor clamp (A) and make sure plunge action is in “UP” position, with the plunge lock lever (B) locked down.
4. Lift the motor straight up out of the base, sliding the motor housing pin (C) free from the slot (D) in the plunge base.
5. Set the motor upside down on its top cap with the collet pointing up and remove the bit.

▲ WARNING: Always remove the cutter bits from the collet/nut when the router is not being used. Leaving bits installed could result in an accidents causing serious personal injury.

ADJUSTING THE DEPTH OF CUT

▲ WARNING: Your router should never be turned on or be connected to the power source when you are assembling parts, making adjustments, installing or removing collets/nuts and cutter bits, cleaning or when it is not in use. Disconnecting the router will prevent accidental starting, which could cause serious personal injury.

PLUNGING ACTION (Fig. 6)

The plunge base features simplify depth adjustment and allow the cutter bit to be accurately lowered into the workpiece for more precise set-ups.

To lower the cutter bit, release the plunge-lock lever by moving it “up” to the unlocked position.

Apply an even, downward pressure on the plunge action until the cutter bit reaches the desired depth, then move the plunge-lock lever “down” to the locked position.

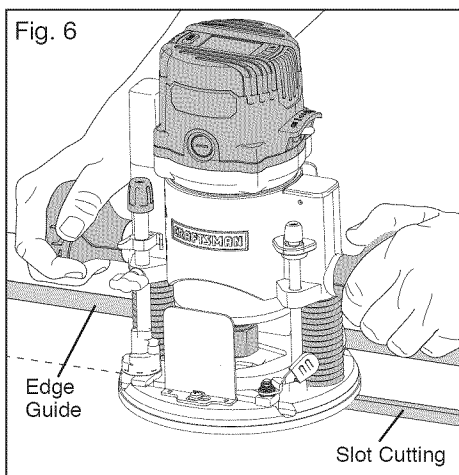

To raise the bit and the plunge action, unlock the plunge-lock lever. The plunge action will automatically retract from the workpiece and return to the raised position.

Always have the plunge action in the raised position and locked when the bit is not cutting in the workpiece.

DEPTH-STOP ROD AND DEPTH-STOP TURRET (Fig. 7)

The depth-stop rod and the depth-stop turret are used to control the plunge action cutting depth as follows:

1. Turn the motor off and unplug the router from the power source.
2. Place the router on a flat, level surface.
3. With the cutter bit already been installed, lower the plunge action until the cutter bit makes contact with the flat, level surface the router is sitting on. Lock the plunge depth locking lever (F). This position is zero - "0" from which further depth adjustments can be made.
4. To set a desired depth-of-cut, rotate depth-stop turret until the lowest step of the turret (A) is aligned directly under the depth-stop rod (B). Loosen the depth rod locking knob (C) and lower the depth-stop rod (B) until it contacts the lowest step on the turret (A).
5. Slide the clear plastic depth-indicator (D) until the red line on the indicator is lined up with zero- "0", marked in black on the bottom of the depth scale. (This is now the indicating point at which the bit makes contact with the workpiece).
6. To set a desired cutting depth, slide the depth-stop rod (B) up until the red line on the clear plastic depth-indicator points to your desired cutting depth on the depth scale (E). Secure the depth-stop rod (B) at this position by tightening the depth rod locking knob (C).
7. Unlock the plunge-depth-locking lever (F) to allow the bit to automatically retract to the up position.
8. The desired depth-of-cut may now be achieved by plunging the router down until the depth-stop rod (B) contacts the selected step on the depth-stop turret (A).

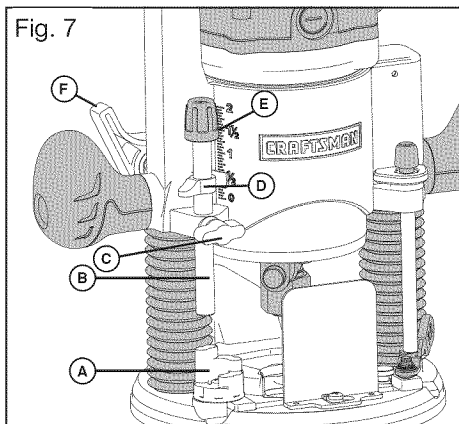

NOTE: When making depth adjustments on the plunge base, the motor clamp should always be closed securely.

Using the Depth-Stop Turret to Set Up Deep Cuts (Fig. 8)

NOTE: Making a single deep cut is never advisable. Smaller diameter cutting bits are easily broken by too much side thrust and torque. Larger cutting bits will cause a rough cut and be difficult to guide and control. For these reasons, do not exceed 1/8 in. depth of cut in a single pass.

To produce deep cuts, always make several progressively deeper cuts by starting with the highest step on the depth-stop turret, and, after each cut, rotate the turret to the next lower step until the lowest step is reached.

Each of the steps progresses by 1/4 inch increments. The 4 steps represent a total of “0” inch to 3/4-inch with a full 360° rotation of the turret. Repeat this process if necessary.

Micro-adjustments with the Depth-Stop Rod and Depth-Stop Turret (Fig. 8)

The depth-stop rod has a micro adjustment knob (A) that turns a screw (B) (inside the rod) either clockwise or counterclockwise to lower or raise the depth-stop rod on the turret (C) for micro-fine adjustments of the plunge depth.

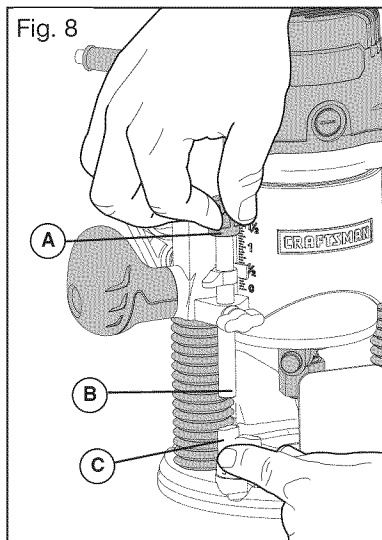

Each complete revolution of the Micro-adjustment knob adjusts the plunging depth by approximately 1/32 inch.

A reference indicator line is embossed into the depth-stop rod under the fine-adjustment knob to set a reference point of “0”.

When micro-adjust the plunge depth, always make sure that the micro-adjustment knob has been turned down (clockwise) several revolutions from the top before setting the depth-stop rod and depth-stop turret.

Always set your micro-adjustments with the plunge action locked in the raised, (or up) position.

To use the micro-adjustment knob after the depth rod and turret have been set, check the final depth setting and micro-adjust as follows:

- To micro-increase the plunge depth, raise the micro-adjustment screw by turning the knob counterclockwise the desired amount.
- To micro-reduce the plunge depth, lower the micro-adjustment screw by turning the knob clockwise the desired amount.

TOGGLE “ON/OFF” SWITCH (Fig. 9)

Your router motor is turned “ON” and “OFF” by the toggle switch located on the top cap of the motor housing.

The left side of the toggle switch hood (as you face it) is marked “I” for “On” and the right side (as you face it) is marked “O” for “Off”.

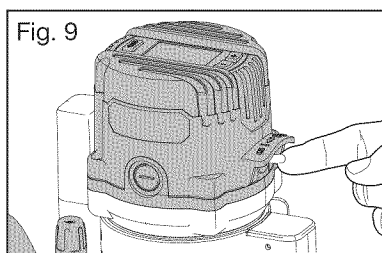

To turn the motor “ON”, Push the toggle switch to the left side marked “I”, or “On”

To turn the motor “OFF” Push the toggle switch to the right side marked “O”, or “Off”.

Always hold the router and the cutter bit away from the workpiece when turning the toggle switch

“On”. Only contact the workpiece with the router and cutter bit after the router has reached full speed. Only remove the router and cutter bit from the workpiece after turning the router motor “OFF”, and the cutter bit comes to a complete stop.

SOFT START FEATURE

Electronic feedback control minimizes torque twist, customary in larger router motors, by limiting the speed at which the motor starts. This increases the motor’s life.

LED WORKLIGHTS (Fig. 10)

Your router motor has 3 built-in worklights located around the collet/nut to provide high visibility of workpiece when cutting. These lights are always “On” when the toggle switch is in the “On” position.

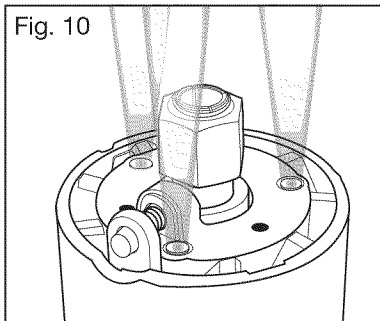

“LIVE TOOL INDICATOR” LIGHT (Fig. 11)

Your router also has a “live tool indicator” green light, located on the motor housing top cap where the power cord enters the motor housing. This green light is always on when router motor is plugged into power source.

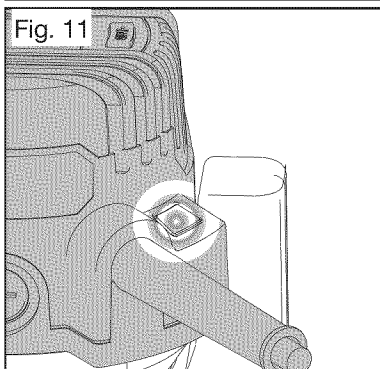

HEAVY-DUTY EDGE GUIDE (SOLD SEPARATELY)

The router comes with a heavy duty edge guide. This edge guide can be used as an aid in routing applications such as decorative edging, straight edge planing and trimming, grooving, dadoing and slotting.

To attach the edge guide to the fixed or plunge base, simply insert the edge guide rods into the edge-guide mounting slots either from left or the right.

Tighten the lever on left by turning it counterclockwise to secure the edge guide rod (Fig. 12). Tighten the lever on right by turning clockwise to secure the rod.

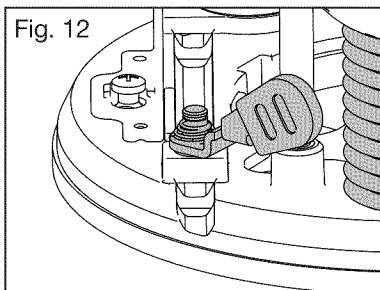

NOTE: If the inner screws wear down or require calibration:

- Pull the lever up and turn it clockwise and then push the lever down (Fig. 13).
- Turn the lever counterclockwise to secure the edge guide.

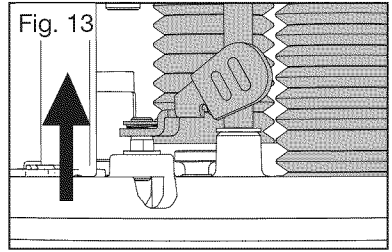

SETTING THE ROUTER (Fig. 14)

⚠ WARNING: When set the digital screen; make sure to turn the toggle on/off switch to the “Off” position. Failure to do so could result in accidental starting.

1. Place the router on a flat workplace; make sure the bit is not contacting the workpiece.
2. Turn the toggle on/off switch to the “Off” position.
3. Plug the digital router in power source, LCD screen reads the specifications of the router (Fig. 14).
4. Press the key “SET”, the type of bit begins flashing. Press “+” or “-” to choose the bit type needed.
5. Re-press “SET”, the size of bit begins flashing. Press “+” or “-” to choose the bit size needed.
6. Re-press “SET”, the material hardness of workpiece to be cut begins flashing. Press “+” or “-” to choose the material of workpiece to be cut.
7. Re-press “SET” again, exit the setting system.
8. The setting speed was displayed on digital screen.
9. Turn the toggle on/off switch to ON.
10. The motor will run per pre-setting speed.

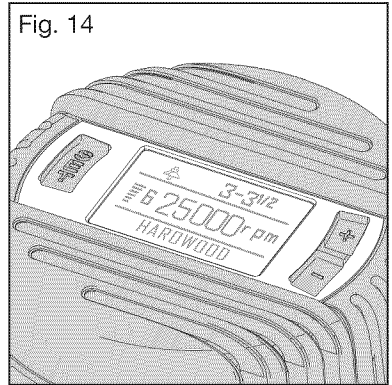

NOTE: If the operator wants to control the speed manually, Directly Press “+” or “-” to choose speed without pressing “SET” key.

NOTE: when the motor is running, “SET” key is useless. operator can only select “+” or “-” to change speed.

ELECTRONIC VARIABLE SPEED CONTROL (Fig. 15)

NOTE: The below chart and all the specifications appear on the display of the router are only for reference for your operation.

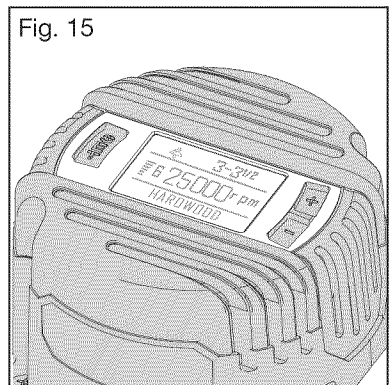







The electronic speed control feature allows motor speed to be matched to cutter size and material hardness for an improved finish and extended bit life.

Press “+” or “-” directly to choose the cutting speed according various materials of workpieces.

Your router motor top cap has a “Variable Speed Selection Chart” located above the “ON/OFF” toggle switch, to help you determine the correct speed for the cutter bit being used.

▲ WARNING: Before operating your router follow all safety instructions in this manual. Failure to do so could result in serious personal injury.

NOTE: Choose the applicable cutting speed according the bit diameter and the material being cut.

Bit Size Materials Hardness							
	0-1”	1.25-2”	2.25-2.5”	3-3.5”			
Plastic	6	4	3	2			
Softwood	6	4	2	1			
Hardwood	5	3	2	1			

Reduce the speed when using extra large bits (1-in more in cutting diameter) or heavy cutting bits. Changing the routers rate of feed can also improve the quality of the cut.

DIAL SETTING	RPM	APPLICATION
1	10,000/11500	Non-ferrous metal, hardwoods, larger diameter cutter bits
2	13,000/14500	
3	16,000/17500	
4	19,000/20500	Softwoods, plastics, countertops, smaller diameter cutter bits
5	22,000/23500	
6	25,000	

The speed charts above indicate the relationship between the speed setting and the cutting application. Exact settings are determined through operator experience and preference, and also by recommendations by manufacturers of cutter bits.

ELECTRONIC FEEDBACK CIRCUITRY

The router electronic feedback circuitry monitors and adjusts power to maintain the desired speed for consistent performance and control, providing constant speed under load for a high-quality finish in all materials.

PLACING THE ROUTER ONTO THE WORKPIECE AND STARTING THE CUT

▲ WARNING: Before operating the router follow all safety instructions in this manual. Failure to do so could result in serious personal injury.

NOTE: Making test cuts is essential with most routing applications. Even with careful set-ups you won't know exactly how the cut will go until you try it out. A test cut will give a feel for the set-up, the router's speed, the depth of cut, and how the cutter bit reacts to the workpiece.

Much of routing is a trial-and-error process of making various adjustments, followed by test cuts as you become familiar with all of your router's operational abilities. To avoid ruining good material, make your test cuts on scrap materials.

How you place your router onto a workpiece (starting the cut) with a plunge base depends on the type of routing you are going to produce: edge routing or internal routing, as discussed on the following pages.

For ease of operation and to maintain proper control, your router has two handles, one on each side of the router base. When operating the router, always hold it firmly with both hands (Fig. 16).

▲ WARNING: Always be alert and watch what you are doing. Never operate the router when you are fatigued.

EDGE ROUTING (Fig. 17)

1. With the depth-of-cut set, place the router on the edge of the workpiece, making sure that the cutter does not contact the workpiece.
2. Clamp an edge guide (or a board or a metal straightedge) in place to help guide the router base.
3. Turn the router "On," and allow the router motor to reach the selected speed.
4. To begin the cut, gradually feed the cutter bit into the edge of the workpiece.

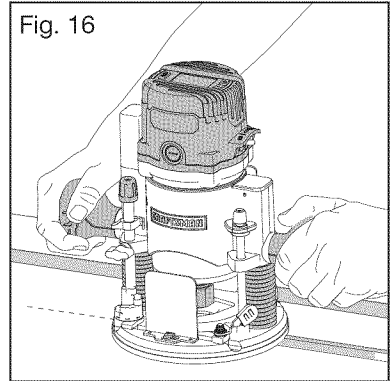
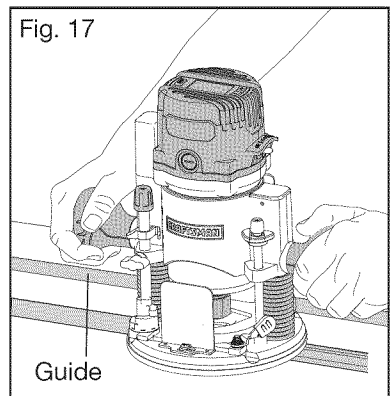

Fig. 17



- When the cut is complete, turn router motor “Off” and allow the cutter bit come to a complete stop before removing it from the workpiece.
- Unplug the router from the power source, place the router on a worktable, and inspect the finished cut in the workpiece.

▲ WARNING: Always securely clamp your workpiece and keep a firm grip on the router base with both hands at all times. Failure to do so could result in loss of control, causing possibly serious personal injury.

▲ WARNING: Removing the cutter bit from the workpiece while it is still rotating could damage the workpiece and result in loss of control, causing serious personal injury.

INTERNAL ROUTING WITH THE PLUNGE BASE (Fig. 18)

- With the depth-of-cut set, and the plunge action locked in the raised (Up) position, turn the router motor “ON” and allow the router motor to reach the selected speed (see Fig. 18).
- To begin your cut, unlock the plunge-lock lever and gently lower the plunge action evenly into the workpiece.
- When the desired depth-of-cut is achieved, lock the plunge-lock lever and proceed to make the cut.
- When the cut is completed, turn the router motor “OFF” and allow the cutting bit come to a complete stop.
- When the cutting bit has come to a complete stop, unlock the plunge lock lever (Up) and the plunge action will automatically retract the cutting bit from the workpiece.

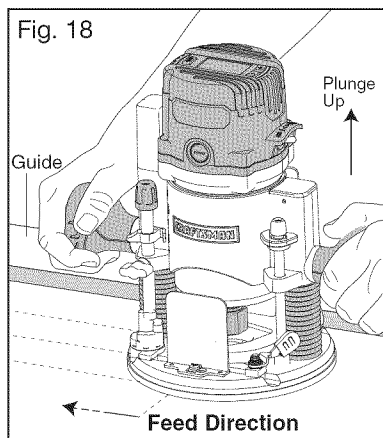

▲ WARNING: Removing the cutter bit from the workpiece while it is still rotating could damage the workpiece and result in loss of control, causing serious personal injury.

- Unplug the router from power source, place the router on the worktable, and inspect the finished cut in the workpiece.

▲ WARNING: Always securely clamp the workpiece in place, and keep a firm grip on the router base with both hands at all times. Failure to do so could result in loss of control, causing serious personal injury.

NOTE: Making test cuts is essential with most routing applications. A test cut will give a feel for the set-up, the router’s speed, the depth of cut, and how the cutting bit reacts to the workpiece.

EDGING WITH A PILOT BIT (Figs. 19 and 19a)

The arbor-type bits with pilots are excellent for edge shaping of any workpiece edge that is straight, or is curved at a curvature as great or greater than the radius of the bit to be used. The pilot prevents the bit from making an excessively deep cut, and holding the pilot firmly in contact with the workpiece edge throughout prevents the cut from becoming too shallow.

Whenever the workpiece thickness, together with the desired depth of cut (as adjusted by router depth setting) are such that only the top part of the edge is to be shaped (leaving at least a 1/16 inch. thick uncut portion at the bottom), the pilot can ride against the uncut portion, which serves to guide it (Fig. 19).

If the workpiece is too thin or if the bit is set so low that there will be no uncut edge against which to ride the pilot, an extra board must be placed under the workpiece to act as a guide (Fig. 19a). This "guide" board must have exactly the same contour - straight or curved - as the workpiece edge. If it is positioned so that its edge is flush with the workpiece edge, the bit will make a full cut (in as far as the bit radius). On the other hand, if the guide is positioned as shown in Fig. 19a (out from the workpiece edge), the bit will make less than a full cut - which will alter the shape of the finished edge.

NOTE: The size (diameter) of the pilot that is used determines the maximum cut width that can be made with the pilot against the workpiece edge (the small pilot exposes all of the bit; the large one reduces this amount by 1/16 inch). Any of the piloted cutter bits can be used without a pilot for edge shaping with guides.

⚠ WARNING: Always securely clamp your workpiece and keep a firm grip on the router base with both hands at all times. Failure to do so could result in loss of control causing possible serious personal injury.

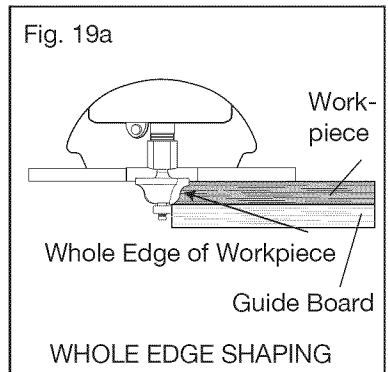
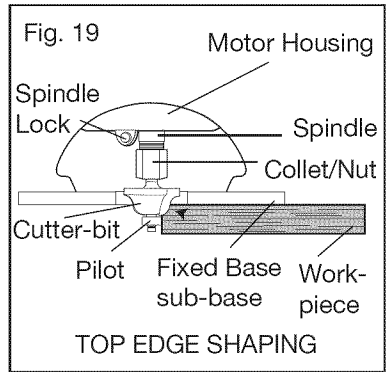

FEEDING THE ROUTER (Fig. 20)

The secrets to professional routing are a careful set-up for the cut, selecting the proper depth of cut, knowing how the cutter bit reacts in your workpiece, and the rate and direction of feed of the router.

DIRECTION OF FEED-- EXTERNAL CUTS

The cutter bit rotates clockwise. Feeding the bit from left to right

will cause the bit to pull the router towards the workpiece (see Fig. 20). If the router is fed in the opposite direction (right to left), the rotating force of the cutter bit will tend to throw the bit away from the workpiece. This is called "Climb-Cutting." "Climb-Cutting" may cause loss of control, possibly resulting in personal injury. When "Climb-Cutting" is required (e.g., backing around a corner), exercise extreme caution to maintain control of the router.

The high speed of the cutter bit during a proper feeding operation (left to right), results in very little kickback under normal conditions. However, if the cutter bit strikes a knot, an area of hard grain, or a foreign object, "Kickback" may result. Kickback may damage your workpiece and could cause you to lose control of the router, possibly causing personal injury. Kickback is always in the opposite direction of the clockwise cutter bit rotation, or counterclockwise.

To guard against and help prevent Kickback, plan your set-up and direction of feed so that you're always keeping the sharp edges of the cutter bit biting straight into uncut wood.

Always inspect your workpiece for knots, hard grain, and foreign objects.

⚠ WARNING: Kickback causes the power tool to jerk back toward the user, causing possible loss of control and serious injury. Always take precautions against kickback as described in the operator's manual.

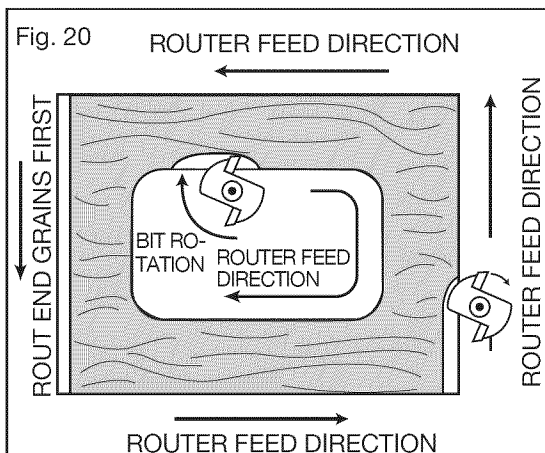

DIRECTION OF FEED - INTERNAL CUTS (Figs. 21 and 21a)

When making an internal cut, such as a groove, dado, or slot, always have the guide you are using with the router (edge guide, straight edge, board guide), on the right-hand side of the router as you make the cut. (Fig. 21)

When the guide is positioned on the right hand side of the router, the router travel should be from left to right and “counterclockwise” around curves (see Fig. 21). This counterclockwise action around the curve could cause “Climb cutting”. Always be alert and exercise extreme caution to maintain control of the router when making this type of cut around curves.

When the guide is positioned as shown in Fig. 21a, the router travel should be from left to right and clockwise around curves.

If there is a choice, the set-up in Fig. 21 is easier to use, but there is the possibility of “Climb Cutting” around curves. In either case, Fig. 21 or Fig. 21a, the sideways thrust of the router cutting is always against the guide, as is proper.

⚠ WARNING: Always securely clamp the workpiece in place, and keep a firm grip on the router base with both hands at all times. Failure to do so could result in loss of control causing possible serious personal injury.

RATE OF FEED (Figs. 22 and 22a)

The proper rate of feed depends on several factors: the hardness and moisture content of the workpiece, the depth of cut, and the cutting diameter of the bit. When cutting shallow grooves in soft woods such as pine, you may use a faster rate of feed. When making deep cuts in hardwoods such as oak, you should use a slower rate of feed.

FEEDING TOO QUICKLY (Fig. 22)

Clean and smooth cuts can only be achieved when the cutter bit is rotating at a relatively high speed, taking very small bites, producing tiny, clean-cut chips.

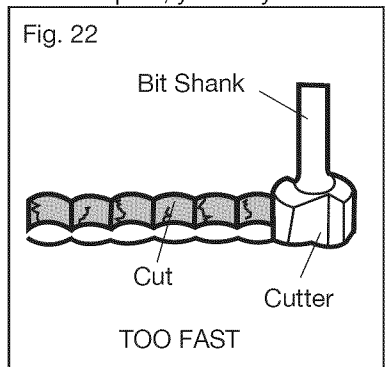
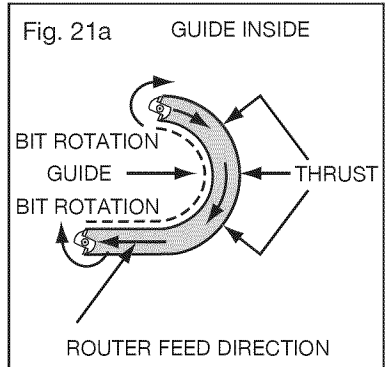
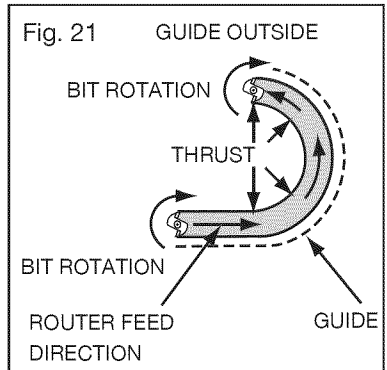

Forcing the feed of the cutter bit forward too quickly slows the rotational speed of the cutter bit, and the bit takes bigger bites as it rotates. Bigger bites cause bigger chips and a rough finish. This forcing action can also cause the router motor to overheat.

Under extreme force-feeding conditions, the speed can become so slow and the bites become so large that chips become partially cut off, causing splintering and gouging of the workpiece.

The router will make clean, smooth cuts if allowed to run freely without the overload of forced feeding. You can detect forced feeding by the sound of the motor. Its usual high-pitched whine will sound lower and stronger as it loses speed. Holding the router against the workpiece will also be strained and harder to do.

FEEDING TOO SLOWLY (Fig. 22a)

When you feed the cutter bit too slowly, the rotating cutter bit does not cut into new wood rapidly enough to take a bite. Instead, it scrapes away sawdust-like particles. This scraping produces heat, which can glaze, burn, and mar the cut in the workpiece and, in extreme cases, overheat the cutter bit.

When the cutter bit is scraping instead of cutting, the router is more difficult to control as you feed it.

With almost no load on the motor, the cutter bit has a tendency to bounce off the sides of the cut in the workpiece, producing a cut with a rippled finish instead of clean straight sides.

CHIP SHIELD (Fig. 23)

▲ WARNING: Always wear eye protection. The chip shields are not intended as safety guards.

The chip shield help keep dust and chips away from the operator, they will not stop objects larger than woodchips thrown from the bit.

The chip shield on the plunge base is held in position by a screw. To remove the chip shield from the plunge base, simply loosen the screw and take the chip shield off of the base (Fig. 23)

▲ WARNING: The chip shield helps keep dust and chips away from the operator; they will not stop objects larger than woodchips thrown from the bit.

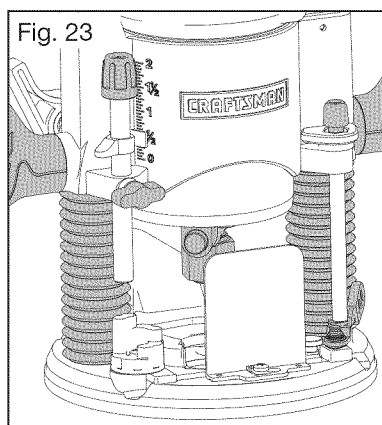
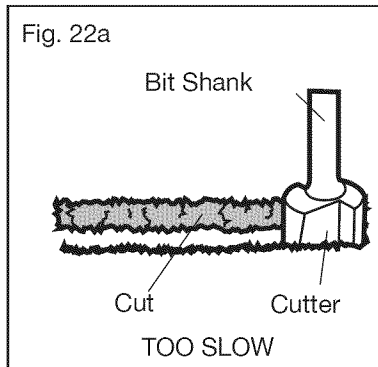

⚠ WARNING: Always have the chip shield in place on the base when operating the router.

⚠ WARNING: Always turn the router motor off and unplug router from power source before making any adjustments or installing accessories. Failure to turn the motor off and unplug the router could result in accidental starting which can cause serious personal injury.

DUST COLLECTION WITH VACUUM PORT (Fig. 24)

Vacuum port is sized to accept a 1-1/4 in. vac hose adapter, sold separately.

To attach the adapter onto the plunge base, position and secure it to the back of the base with the two screws (included), as shown in Fig. 24

The vacuum port can also be installed with the hose outlet facing the front of the plunge base by removing the chip shield and attaching the adapter at the front of the base.

⚠ WARNING: Always turn the router motor off and unplug router from power source before making any adjustments or installing accessories. Failure to turn motor off and unplug router could result in accidental starting which can cause serious personal injury.

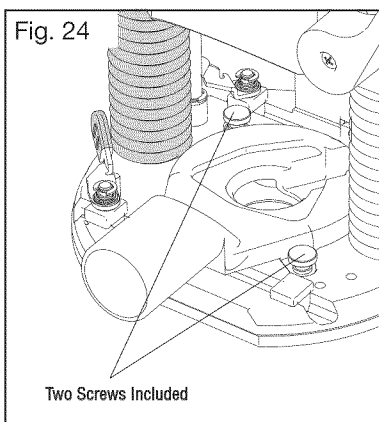

Fig. 24

Two Screws Included

TO ADJUST DEPTH WITH DEPTH-ADJUSTMENT WRENCH (Figs. 25, 26)

NOTE: The Depth-Adjustment Wrench supplied is used to adjust the depth when the router is fixed to the router table (Model No. 320. 28180), sold separately. (Fig. 25)

⚠ WARNING: Always read and follow all directions for mounting the router to a router table and for use of the router table.

⚠ WARNING: Always turn the router motor off and unplug the router from the power source before making any adjustments or installing accessories. Failure to turn router motor off and unplug the router could result in accidental starting, which can cause serious personal injury.

⚠ WARNING: Only use router tables with proper guarding for the cutting bit and with "on-board," switch-controlled receptacles. Failure to use router tables with appropriate safety features could result in serious personal injury.

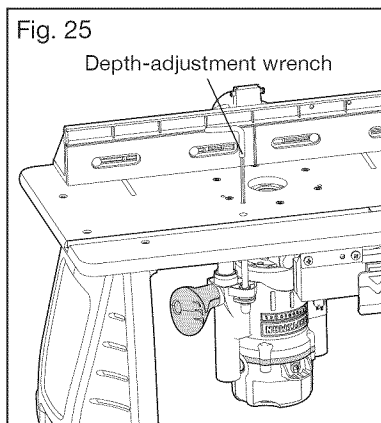
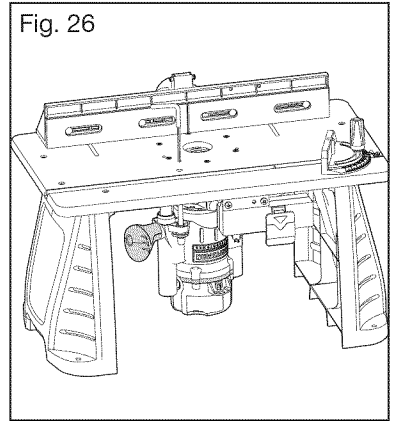

Fig. 25

Depth-adjustment wrench

When using the plunge base to attach the router to the router table, the bit depth can be adjusted by turning the depth rod clockwise or counterclockwise with the wrench supplied (Fig. 26).

1. Turn off the router.
2. Lock the plunge depth locking lever.
3. Insert the wrench into the adjusting hole on the tabletop. Turn the depth rod on the router clockwise with the wrench to move the collet/nut up or counterclockwise to move the collet/nut down.
4. When the desired depth of cut is set, tighten the clamping lever. The precise depth of cut can be measured with a ruler



MAINTENANCE

⚠ WARNING: To ensure safety and reliability, all repairs should be performed by a qualified service technician at a Sears Service Center.

GENERAL

Only the parts shown on the parts list are intended for repair or replacement by the customer. All other parts represent an important part of the double-insulation system and should be serviced only by a qualified Craftsman service technician.

⚠ WARNING: For your safety, always turn off the switch and unplug the router motor from the power source before performing any maintenance or cleaning.

It has been found that electric tools are subject to accelerated wear and possible premature failure when they are used to work on fiberglass boats and sports cars, wallboard, spackling compounds or plaster. The chips and grindings from these materials are highly abrasive to electrical tool parts, such as bearings, brushes, commutators, etc. Consequently, it is not recommended that this tool be used for extended work on any fiberglass material, wallboard, spackling compound, or plaster. During any use on these materials, it is extremely important that the tool is cleaned frequently by blowing with an air jet.

⚠ WARNING: Always wear safety goggles or safety glasses with side shields during power tool operations, or when blowing dust. If operation is dusty, also wear a dust mask.

ROUTINE MAINTENANCE

⚠ WARNING: Do not at any time allow brake fluids, gasoline; petroleum-based products, penetrating oils, etc. come in contact with plastic parts. Chemicals can damage, weaken, or destroy plastic, which may result in serious personal injury.

1. When work has been completed, clean the tool to allow smooth functioning of the tool over time.
2. Use clean, damp cloths to wipe the tool.
3. Check the state of all electrical cables.
4. Keep the motor air openings free from oil, grease, and sawdust or woodchips, and store the tool in a dry place.
5. Be certain that all moving parts are well lubricated, particularly after lengthy exposure to damp and/or dirty conditions.

⚠ WARNING: For your safety, always turn off the switch and unplug the router motor from the power source before performing any maintenance or cleaning.

Refer to “Collet/Nut Care and Cutter bits” for cleaning care.

REPLACEMENT OF CARBON BRUSHES (Fig. 27)

Replacement brush sets are available through Sears Parts and Repair Centers.

1. Unplug the router motor before inspecting or replacing brushes.
2. Replace both carbon brushes when either has less than 1/4 in. length of carbon remaining, or if the spring or wire is damaged or burned.
3. Using a slotted screwdriver, remove the black, plastic cap on each side of the router motor (Fig. 27) and carefully withdraw the spring-loaded brush assemblies. Keep brushes clean and sliding freely in their guide channels.

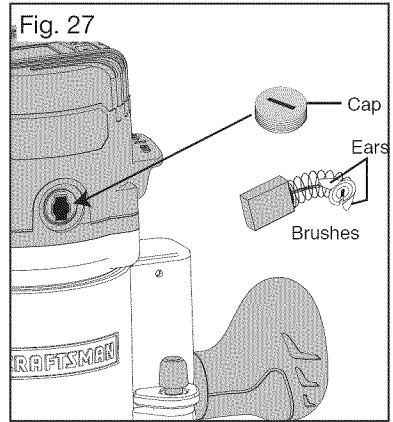

NOTE: To reinstall the same brushes, make sure that the brushes go back in the same way they came out. This will avoid the need for a break-in period.

4. Insert new brush assemblies into the guide channels with the carbon part going in first, being certain to fit the two metal “ears” into their slots in the channel (Fig. 27).
5. Remember to replace both end caps after inspecting or servicing brushes. Tighten the caps snugly, but do not over-tighten. The router should be allowed to “run in” (run at no load without a cutter bit) for 5 minutes before use, to seat the new brushes properly.

⚠ WARNING: For your safety, always turn off the switch and unplug the router motor from the power source before performing any maintenance or cleaning.

LUBRICATION

All of the bearings in this tool are lubricated with a sufficient amount of high-grade lubricant for the life of the tool under normal operating conditions. Therefore, no further lubrication is required.

TROUBLESHOOTING

PROBLEM	CAUSE	SOLUTION
The router does not work	Plug is not plugged into the power source.	Plug the cord into the power source.
	Switch is in "OFF" position.	Pull the switch to "ON" position.
	The carbon brushes have worn out completely.	Remove the carbon brush caps, and replace the old brushes with new ones.
The surface of the workpiece is not smooth after cutting	The bit is dull.	Change to a sharp bit.
	Routing at an inappropriate bit speed	Select an appropriate bit speed.
Bit can not be installed	Bit size is inappropriate for the collet/nut	Use only 1/4 in. diameter bits with the 1/4 in. collet; use only 1/2 in. diameter bits with the 1/2 in. collet.

















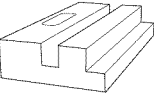

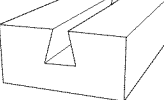

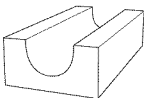

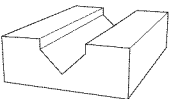

ACCESSORIES CONT



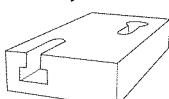
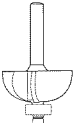
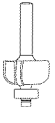

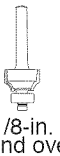



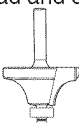

⚠ WARNING: The use of attachments or accessories that are not recommended for this tool might be dangerous and could result in serious injury. Sears and other Craftsman outlets offer a large selection of Craftsman router accessories designed for specific routing applications.

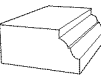
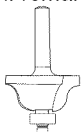
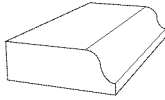
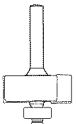
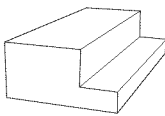
There is a large selection of Craftsman Router Cutting bits available in High-Speed Steel or Carbide Tipped High-Speed Steel for all your routing needs.

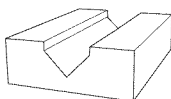
In addition to a wide variety of router bits, Sears also offers accessories such as: Router tables, various template sets, universal router fence with lock knobs (64181), 11 pc. bushing set (64180) and clear sub-base sets; 6pc. fixed base (64182) 6 pc. plunge base (64183).

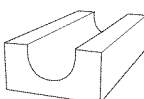
⚠ WARNING: Only use router tables with proper guarding for the cutting bit and with "on-board" switch controlled receptacles. Failure to use router tables with appropriate safety features could result in serious personal injury.

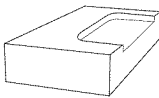
<p>1/8-in. straight</p>  <p>5/16-in. straight</p>  <p>3/8-in. straight</p>  <p>1/2-in. straight</p>  <p>1/4-in. straight</p>  <p>3/4-in. straight</p> 	<p>straight</p> 
<p>3/8-in. dove tail</p>  <p>1/2-in. dove tail</p> 	<p>dovetail</p> 
<p>1/2-in. round nose</p> 	<p>round nose</p> 
<p>1/2-in. 90 d v groove</p> 	<p>v groove</p> 
<p>1/2 x 1-in. flush trim</p>  <p>1/2-in. flush trim</p>  <p>3/8x1/2-in. flush trim</p>  <p>1/4-in. flush trim</p> 	<p>flush trim</p> 
<p>3/8-in. keyhole</p> 	<p>keyhole</p> 
<p>1/2-in. cove</p>  <p>1/4-in. cove</p> 	<p>cove</p> 
<p>3/8-in. round over</p>  <p>1/8-in. round over</p>  <p>1/4-in. round over</p>  <p>1/2-in. round over</p> 	<p>round over</p> 

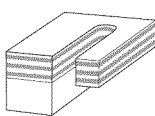
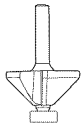
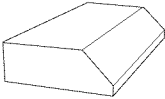
<p>1/2-in. bead and cove</p>  <p>1/16-in. classic cove with bead</p> 	 <p>bead cove</p>  <p>classic cove & bead</p>
<p>1/4-in. roman ogee</p> 	<p>Roman ogee</p> 
<p>3/8-in. rabbeting</p> 	<p>rabbeting</p> 
<p>1/4-in. veining</p> 	<p>veining</p> 
<p>1/2-in. core box</p> 	<p>core box</p> 
<p>1/2-in. mortising</p> 	<p>mortising</p> 
<p>1/4-in. panel pilot</p> 	<p>panel pilot</p> 
<p>1-3/8-in. 45° chamfer</p> 	<p>chamfer</p> 

PARTS LIST

12.0 amp digital plunge base router Model No. 320.27669. The Model Number will be found on the Nameplate attached to the motor unit . Always mention the Model Number when ordering parts for this tool.

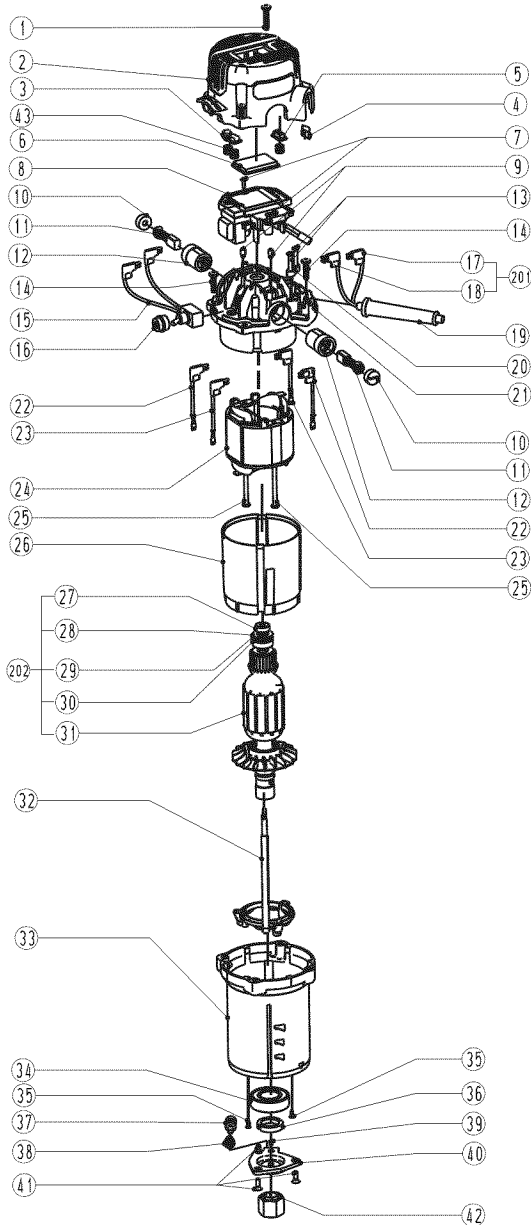

PARTS LIST

12.0 amp digital plunge base router Model No. 320.27669. The Model Number will be found on the Nameplate attached to the motor unit . Always mention the Model Number when ordering parts for this tool.

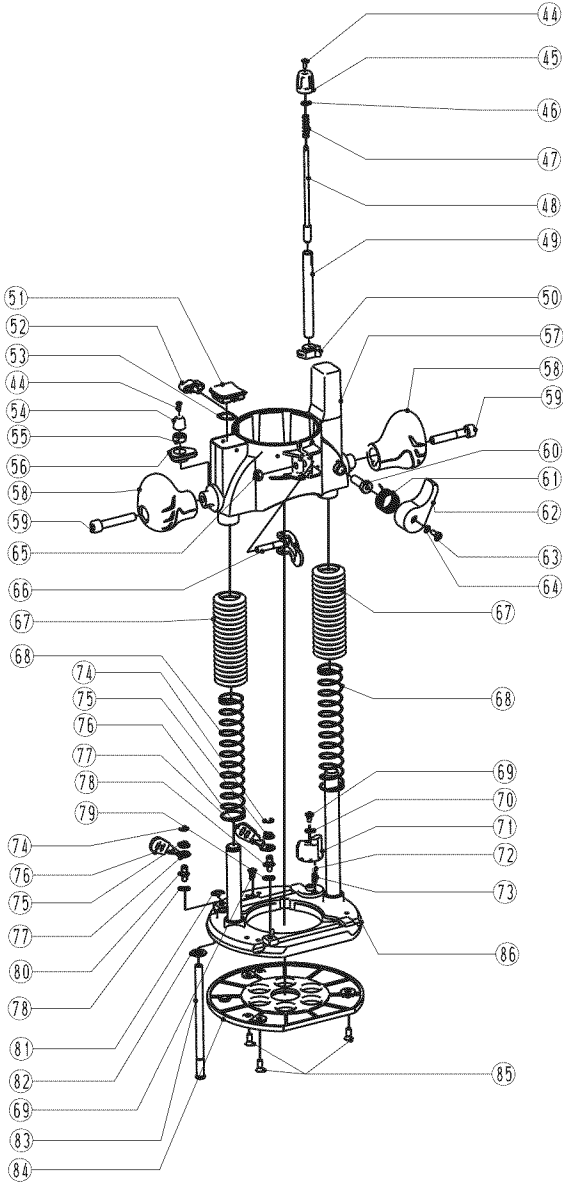

PARTS LIST

12.0 amp digital plunge base router Model No. 320.27669. The Model Number will be found on the Nameplate attached to the motor unit . Always mention the Model Number when ordering parts for this tool.

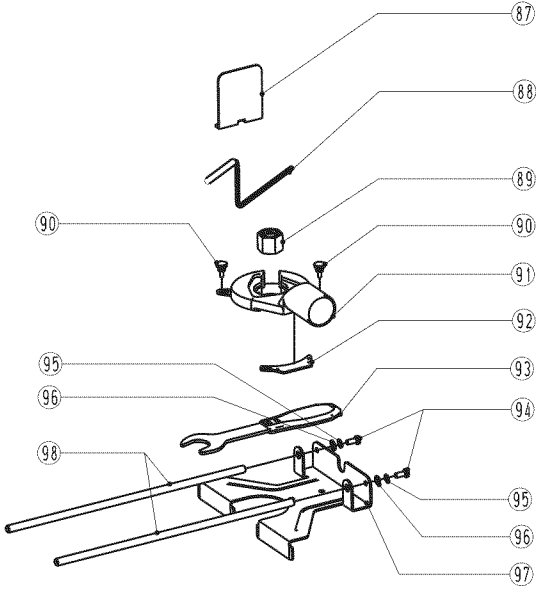

EXPLOSIVE DRAWING

No	Part No	Part Name	QTY
1	5610220000	Screw	2
2	3321132000	Rear Cover	1
3	3125682000	Adjusting Knob	1
4	3121518000	Transparent Cap	1
5	3125683000	Knob	1
6	3125686000	Window display	1
7	5610017000	Tapping Screw	2
8	4890638000	Speed Adjustor	1
9	5620017000	Screw	2
10	3120537000	Brush Cover	2
11	4960019000	Carbon Brush Assy	2
12	2800005000	Brush Holder Assy	2
13	5610106000	Tapping Screw	2
14	5610059000	Screw	2
15	2823115000	Switch Assy	1
16	3122851000	Seal Ring	1
201	4810002000	Power Cord Assy	1
17	4930008000	Sleeve	2
18	4930038000	Receptacle	2
19	3121064000	Cord Guard	1
20	3122798000	Cord Anchorage	1
21	3125685000	Middle Housing	1
22	2822038000	Inner Wire Assy	2
23	2822039000	Inner Wire Assy	2
24	2740118000	Stator	1
25	5610049000	Tapping Screw	2
26	3125687000	Fan Baffle	1
202	2823114000	Rotor Set	1
27	3402387000	Magnet Ring	1

No	Part No	Part Name	QTY
28	3700249000	Washer	1
29	3121049000	Rubber Spring	1
30	5700008000	Ball Bearing	1
31	2750184000	Rotor	1
32	2823021000	LED Holder Assy	1
33	3421186000	Motor Housing	1
34	5700056000	Ball Bearing	1
35	5610076000	Tapping Screw	2
36	5630179000	Nut	1
37	3551635000	Spindle Lock	1
38	3660174000	Stop Spring	1
39	5620061000	Screw	1
40	3421190000	Spindle Lock Cover	1
41	5620069000	Screw	3
42	2823121000	Collet Assembly	1
43	3660512000	Compression Spring	3
44	5620032000	Screw	2
45	3123435000	Adjusting Knob	1
46	5650014000	Plain Washer	1
47	3660313000	Spring	1
48	3550083000	Depth Adjusting Bolt	1
49	3550913000	Depth Stop Bar	1
50	3121634000	Depth Indicator	1
51	3121639000	Cover	1
52	3402338000	Lock Bolt	1
53	5660018000	Circlips	1
54	3123498000	Cap	1
55	5630016000	Nut	1
56	3123497000	Cover	1
57	2823123000	Plunge Frame	1

No	Part No	Part Name	QTY
58	3121635000	Handle	2
59	5620024000	Screw	2
60	5640045000	Bolt	1
61	3660254000	Torsion Spring	1
62	3420398000	Plunge Lock Lever	1
63	5620040000	Screw	1
64	5650007000	Spring Washer	1
65	5630015000	Nut	1
66	2823122000	Lever Assy	1
67	3123581000	Bollows Seal	2
68	3660166000	Spring	2
69	5620103000	Screw	2
70	3700078000	Wave Washer	1
71	3420387000	Turntable	1
72	5700046000	Steel Ball	1
73	3660030000	Spring	1
74	5660005000	"E" Ring	2
75	3660498000	Spring	2
76	3126054000	Handle Sleeve	2
77	3705047000	Lever	2
78	5620466000	Screw	1
79	5650407000	Wave Washer	2
80	5620467000	Screw	1
81	5660319000	"E" Ring	1
82	5650023000	Washer	1
83	3550929000	Bolt	1
84	3122923000	Base Plate	1
85	5620074000	Screw	3
86	2823112000	Mounting Assy	1
87	3123344000	Chip Shield	1

No	Part No	Part Name	QTY
88	3402220000	Depth Adjusting Lever	1
89	2823125000	Collet Assembly	1
90	5620353000	Screw	2
91	3123454000	Vaccum Adapter	1
92	3123500000	Support Plate	1
93	3402471000	Wrench	1
94	5620050000	Screw	2
95	5650015000	Spring Washer	2
96	5650013000	Washer	2
97	3703925000	Fence	1
98	3550588000	Guiding Rod	2

Get it fixed, at your home or ours!

Your Home

For troubleshooting, product manuals and expert advice:



www.managemylife.com

For repair – **in your home** – of **all** major brand appliances, lawn and garden equipment, or heating and cooling systems, **no matter who made it, no matter who sold it!**

For the replacement parts, accessories and owner's manuals that you need to do-it-yourself.

For Sears professional installation of home appliances and items like garage door openers and water heaters.

1-800-4-MY-HOME®

(1-800-469-4663)

www.sears.com

Call anytime, day or night

(U.S.A. and Canada)

www.sears.ca

Our Home

For repair of carry-in items like vacuums, lawn equipment, and electronics, call anytime for the location of the nearest

Sears Parts & Repair Service Center

1-800-488-1222 (U.S.A.)

www.sears.com

1-800-469-4663 (Canada)

www.sears.ca

To purchase a protection agreement on a product serviced by Sears:

1-800-827-6655 (U.S.A.)

1-800-361-6665 (Canada)

Para pedir servicio de reparación a domicilio, y para ordenar piezas:

1-888-SU-HOGAR®

(1-888-784-6427)

www.sears.com

Au Canada pour service en français:

1-800-LE-FOYER^{MC}

(1-800-533-6937)

www.sears.ca

Sears

® Registered Trademark / TM Trademark of KCD IP, LLC in the United States, or Sears Brands, LLC in other countries

© Marca Registrada / TM Marca de Fábrica de KCD IP, LLC en Estados Unidos, o Sears Brands, LLC in otros países

^{MC} Marque de commerce / ^{MD} Marque déposée de Sears Brands, LLC