

**50ZP  
10 SEER  
Single Packaged Air Conditioner  
3–5 Nominal Tons (Sizes 036–060)**



**UNIT SHIPPED DRY, CHARGE WITH R-22  
REFRIGERANT BEFORE START-UP**

# Installation Instructions

**NOTE:** Read the entire instruction manual before starting the installation.

## TABLE OF CONTENTS

|  | PAGE  |
|--|-------|
| SAFETY CONSIDERATIONS .....  | 1     |
| General .....  | 2     |
| RECEIVING AND INSTALLATION .....   | 5-9   |
| Check Equipment .....  | 5     |
| Identify Unit .....  | 5     |
| Inspect Shipment .....   | 5     |
| Provide Unit Support .....   | 5     |
| Slab Mount .....   | 5     |
| Provide Clearances .....   | 5     |
| Place Unit .....   | 5     |
| Select and Install Ductwork .....  | 5     |
| Install Flanges for Ductwork Connections (50ZP060 only) .                    | 5     |
| Converting Horizontal Discharge Units to Downflow (Vertical) Discharge ..... | 6     |
| Charging Unit .....  | 6     |
| Provide for Condensate Disposal .....  | 6     |
| Install Electrical Connections .....   | 8     |
| High Voltage Connections .....   | 8     |
| Routing Power Leads into Unit .....  | 8     |
| Connecting Ground Lead to Unit Ground .....                                  | 8     |
| Routing Control Power Wires .....  | 8     |
| Special Procedures for 208-V Operation .....                                 | 9     |
| PRE-START-UP .....   | 9     |
| START-UP .....   | 10-11 |
| MAINTENANCE .....  | 11-13 |
| TROUBLESHOOTING .....  | 13    |
| START-UP CHECKLIST .....   | 13    |

**NOTE:** TO INSTALLER - Before the installation , READ THESE INSTRUCTIONS CAREFULLY AND COMPLETELY. Also, make sure the User's Manual is left with the unit after installation.

## SAFETY CONSIDERATIONS

Improper installation adjustment, alteration, service, maintenance, or use can cause explosion, fire, electrical shock, or other conditions which may cause death, personal injury, or property damage. Consult a qualified installer, service agency, or your distributor or branch for information or assistance. The qualified installer or agency must use factory-authorized kits or accessories when modifying this product Refer to the individual instructions packaged with the kits or accessories when installing.

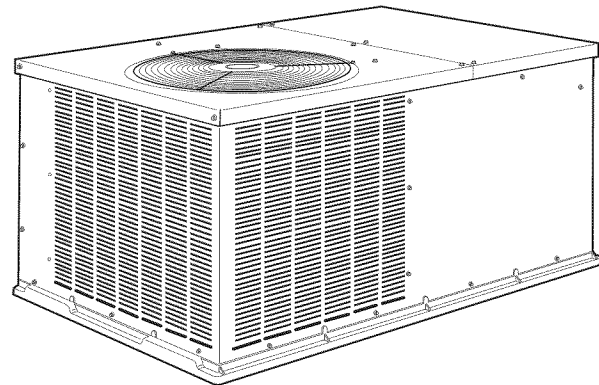

C00001

**Fig. 1 - 50ZP (Size 036 Shown)**

Follow all safety codes. Wear safety glasses, protective clothing, and work gloves. Use quenching cloth for brazing operations. Have a fire extinguisher available. Read these instructions thoroughly and follow all warnings or cautions included in literature and attached to the unit. Consult local building codes, the current editions of the National Electrical Code (NEC) NFPA 70.

In Canada refer to the current editions of the Canadian Electrical Code CSA C22.1.

Recognize safety information. This is the safety-alert symbol . When you see this symbol on the unit and in instructions or manuals, be alert to the potential for personal injury. Understand these signal words; DANGER, WARNING, and CAUTION. These words are used with the safety-alert symbol. DANGER identifies the most serious hazards which **will** result in severe personal injury or death. WARNING signifies hazards which **could** result in personal injury or death. CAUTION is used to identify unsafe practices which **may** result in minor personal injury or product and property damage. NOTE is used to highlight suggestions which **will** result in enhanced installation, reliability, or operation.

## **WARNING**

### **ELECTRICAL SHOCK HAZARD**

Failure to follow this warning could result in personal injury or death.

Before installing or servicing system, always turn off main power to system and install lockout tag. There may be more than one disconnect switch.

**50ZP**

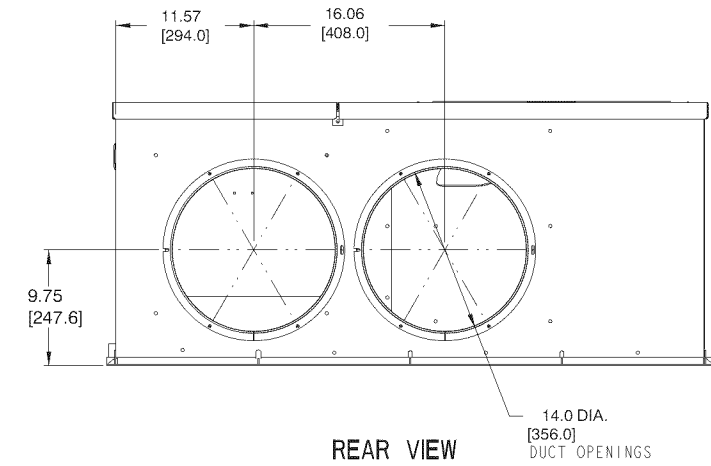

**REQUIRED CLEARANCE TO COMBUSTIBLE MATL.**

|                           | INCHES [mm] |
|---------------------------|-------------|
| TOP OF UNIT .....         | 0           |
| DUCT SIDE OF UNIT .....   | 0           |
| SIDE OPPOSITE DUCTS ..... | 0           |
| BOTTOM OF UNIT .....      | 0           |

**NEC. REQUIRED CLEARANCES.**

|  | INCHES [mm]    |
|--|----------------|
| BETWEEN UNITS, POWER ENTRY SIDE .....  | 42.00 [1066.8] |
| UNIT AND UNGROUNDED SURFACES, POWER ENTRY SIDE .....                                 | 36.00 [914.0]  |
| UNIT AND BLOCK OR CONCRETE WALLS AND OTHER GROUNDED SURFACES, POWER ENTRY SIDE ..... | 42.00 [1066.8] |

**REQUIRED CLEARANCE FOR OPERATION AND SERVICING**

|                                  | INCHES [mm]    |
|----------------------------------|----------------|
| CONDENSER COIL ACCESS SIDE ..... | 30.00 [762.0]  |
| POWER ENTRY SIDE .....           | 30.00 [762.0]  |
| (EXCEPT FOR NEC REQUIREMENTS)    |                |
| UNIT TOP .....                   | 48.00 [1219.2] |
| SIDE OPPOSITE DUCTS .....        | 30.00 [762.0]  |

**LEGEND**

NEC – National Electrical Code

**NOTES:**

- Clearances must be maintained to prevent recirculation of air from outdoor-fan discharge, with the exception of the condenser coil (36.00 in [914.0 mm]). A removable fence or barricade requires no clearance.
- Dimensions are in inches. Dimensions in [ ] are in millimeters.

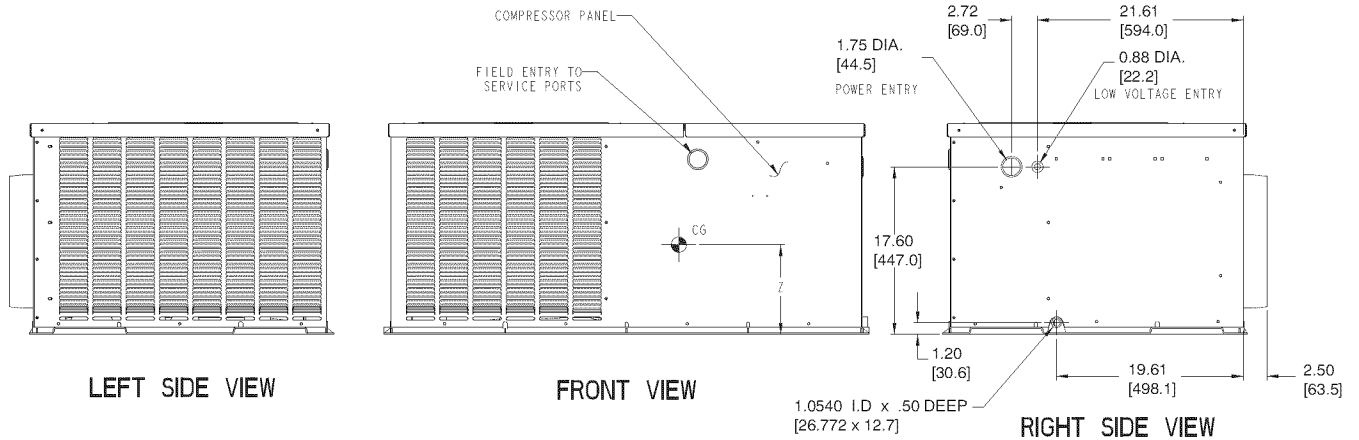
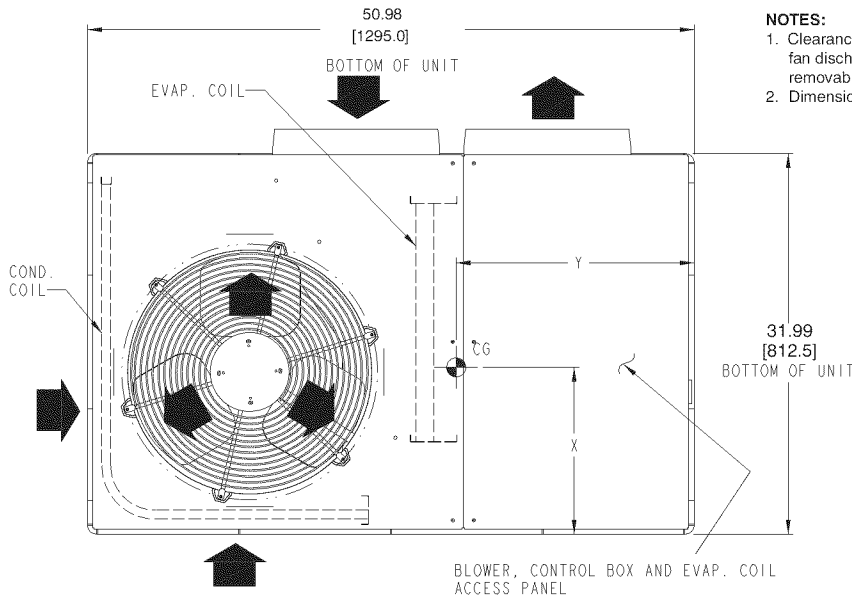

**Fig. 2 - Base Unit Dimensions, 50ZP036**

C00002

| UNIT    | ELECTRICAL CHARACTERISTICS | UNIT WEIGHT |     | CENTER OF GRAVITY IN. (MM) |                  |                 |
|---------|----------------------------|-------------|-----|----------------------------|------------------|-----------------|
|         |                            | lb          | kg  | X                          | Y                | Z               |
| 50ZP036 | 208/230-1-60, 208/230-3-60 | 234         | 106 | 355.6<br>(14.00)           | 508.0<br>(20.00) | 241.3<br>(9.50) |

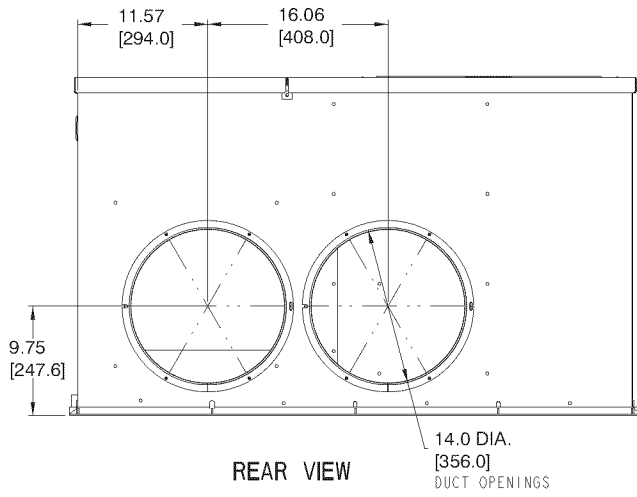

**REQUIRED CLEARANCE TO COMBUSTIBLE MATL.**

|                          | INCHES [mm] |
|--------------------------|-------------|
| TOP OF UNIT.....         | 0           |
| DUCT SIDE OF UNIT.....   | 0           |
| SIDE OPPOSITE DUCTS..... | 0           |
| BOTTOM OF UNIT.....      | 0           |

**NEC. REQUIRED CLEARANCES.**

|   | INCHES [mm]    |
|---|----------------|
| BETWEEN UNITS, POWER ENTRY SIDE.....  | 42.00 [1066.8] |
| UNIT AND UNGROUNDED SURFACES, POWER ENTRY SIDE.....                                 | 36.00 [914.0]  |
| UNIT AND BLOCK OR CONCRETE WALLS AND OTHER GROUNDED SURFACES, POWER ENTRY SIDE..... | 42.00 [1066.8] |

**REQUIRED CLEARANCE FOR OPERATION AND SERVICING**

|  | INCHES [mm]    |
|--|----------------|
| CONDENSER COIL ACCESS SIDE.....                        | 30.00 [762.0]  |
| POWER ENTRY SIDE.....<br>(EXCEPT FOR NEC REQUIREMENTS) | 30.00 [762.0]  |
| UNIT TOP.....  | 48.00 [1219.2] |
| SIDE OPPOSITE DUCTS.....                               | 30.00 [762.0]  |

**LEGEND**

NEC – National Electrical Code

**NOTES:**

- Clearances must be maintained to prevent recirculation of air from outdoor-fan discharge, with the exception of the condenser coil (36.00 in [914.0 mm]). A removable fence or barricade requires no clearance.
- Dimensions are in inches. Dimensions in [ ] are in millimeters.

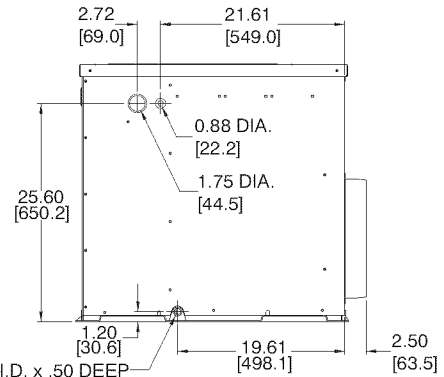
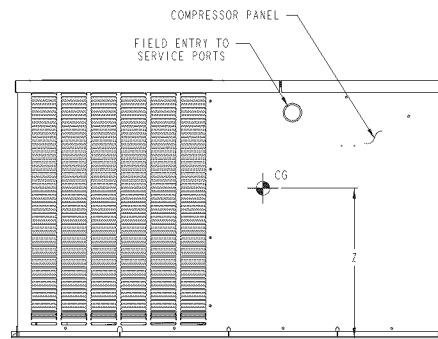
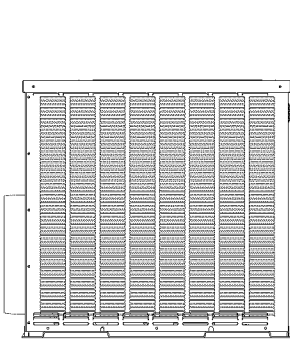
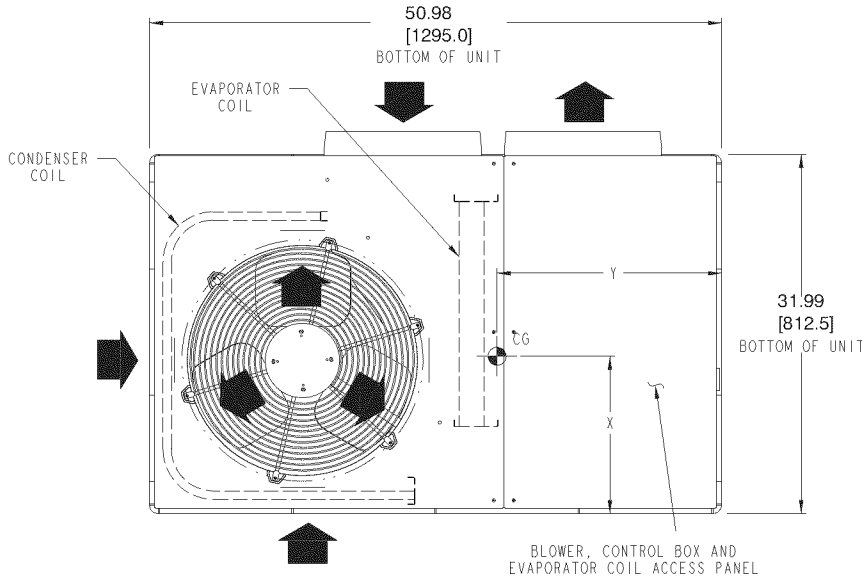

**Fig. 3 - Base Unit Dimensions, 50ZP048**

C00003

| UNIT    | ELECTRICAL CHARACTERISTICS | UNIT WEIGHT |     | CENTER OF GRAVITY IN. (MM) |                  |                  |
|---------|----------------------------|-------------|-----|----------------------------|------------------|------------------|
|         |                            | lb          | kg  | X                          | Y                | Z                |
| 50ZP048 | 208/230-1-60, 208/230-3-60 | 308         | 140 | 355.6<br>(14.00)           | 508.0<br>(20.00) | 304.8<br>(12.00) |

**50ZP**

DIMENSIONS IN [ ] ARE IN mm

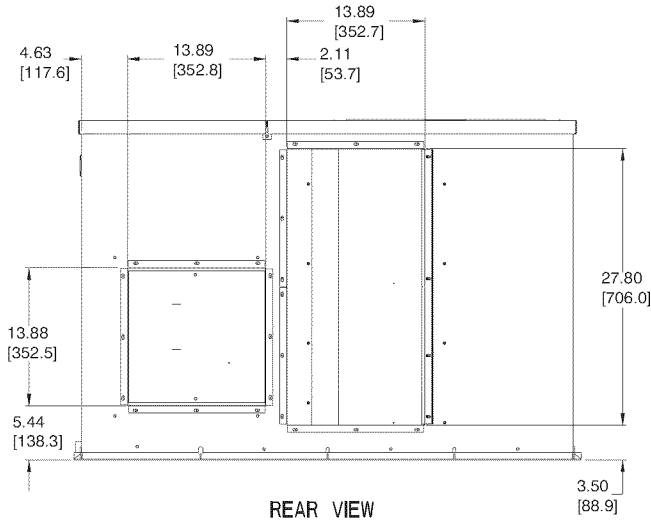

**REQUIRED CLEARANCE TO COMBUSTIBLE MATL.**

|                           | INCHES [mm] |
|---------------------------|-------------|
| TOP OF UNIT .....         | 0           |
| DUCT SIDE OF UNIT .....   | 0           |
| SIDE OPPOSITE DUCTS ..... | 0           |
| BOTTOM OF UNIT .....      | 0           |

**NEC. REQUIRED CLEARANCES.**

|  | INCHES [mm]    |
|--|----------------|
| BETWEEN UNITS, POWER ENTRY SIDE .....  | 42.00 [1066.8] |
| UNIT AND UNGROUNDED SURFACES, POWER ENTRY SIDE .....                                 | 36.00 [914.0]  |
| UNIT AND BLOCK OR CONCRETE WALLS AND OTHER GROUNDED SURFACES, POWER ENTRY SIDE ..... | 42.00 [1066.8] |

**REQUIRED CLEARANCE FOR OPERATION AND SERVICING**

|                                  | INCHES [mm]    |
|----------------------------------|----------------|
| CONDENSER COIL ACCESS SIDE ..... | 30.00 [762.0]  |
| POWER ENTRY SIDE .....           | 30.00 [762.0]  |
| (EXCEPT FOR NEC REQUIREMENTS)    |                |
| UNIT TOP .....                   | 48.00 [1219.2] |
| SIDE OPPOSITE DUCTS .....        | 30.00 [762.0]  |

**LEGEND**

NEC – National Electrical Code

**NOTES:**

- Clearances must be maintained to prevent recirculation of air from outdoor-fan discharge, with the exception of the condenser coil (36.00 in [914.0 mm]). A removable fence or barricade requires no clearance.
- Dimensions are in inches. Dimensions in [ ] are in millimeters.

**50ZP**

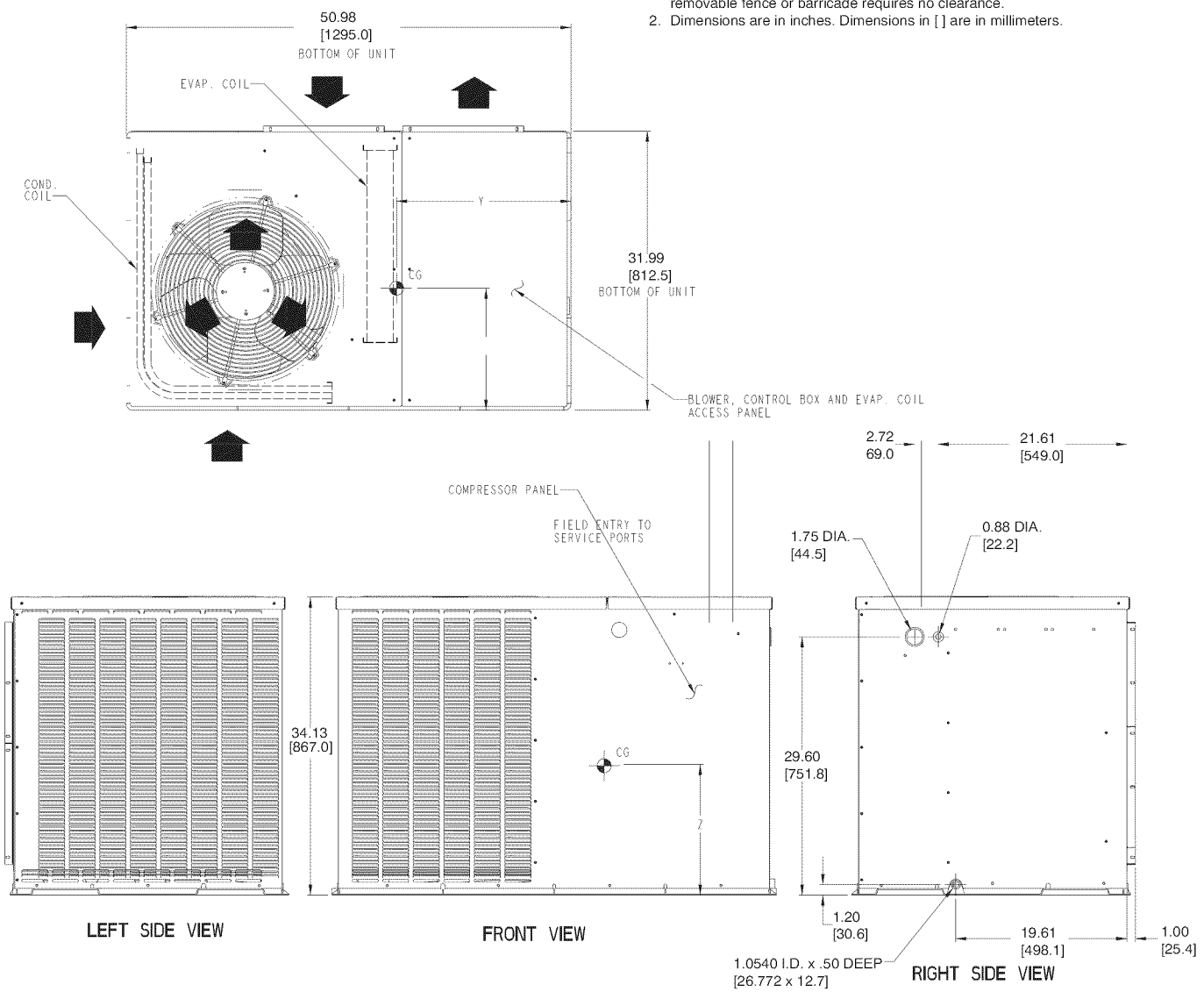

**Fig. 4 - Base Unit Dimensions, 50ZP060**

C00004

| UNIT    | ELECTRICAL CHARACTERISTICS | UNIT WEIGHT |     | CENTER OF GRAVITY IN. (MM) |                  |                  |
|---------|----------------------------|-------------|-----|----------------------------|------------------|------------------|
|         |                            | lb          | kg  | X                          | Y                | Z                |
| 50ZP060 | 208/230-1-60, 208/230-3-60 | 344         | 156 | 355.6<br>(14.00)           | 508.0<br>(20.00) | 355.6<br>(14.00) |



## CAUTION

### CUT HAZARD

Failure to follow this caution may result in personal injury. Sheet metal parts may have sharp edges or burrs. Use care and wear appropriate clothing.

These instructions cover minimum requirements and conform to existing national standards and safety codes. In some instances, these instructions exceed certain local codes and ordinances, especially those that may not have kept up with changing residential construction practices. We require these instructions as a minimum for a safe installation.

**GENERAL** — 50ZP cooling units are fully self-contained and designed for outdoor installation. See Fig. 1. As shown in Fig. 2-4, units are shipped in a horizontal-discharge configuration for installation on a ground-level slab. All units can be field-converted to downflow discharge configurations for rooftop applications with a field-supplied plenum

## RECEIVING AND INSTALLATION

### Step 1 — Check Equipment

**IDENTIFY UNIT** — The unit model number and serial number are stamped on the unit identification plate. Check this information against shipping papers.

**INSPECT SHIPMENT** — Inspect for shipping damage while unit is still on shipping pallet. If unit appears to be damaged or is torn loose from its securing points, have it examined by transportation inspectors before removal. Forward claim papers directly to transportation company. Manufacturer is not responsible for any damage incurred in transit.

Check all items against shipping list. Immediately notify the nearest Carrier Air Conditioning office if any item is missing.

To prevent loss or damage, leave all parts in original packages until installation.

### Step 2 — Provide Unit Support

**SLAB MOUNT** — Place the unit on a rigid, level surface, suitable to support the unit weight. The flat surface should extend approximately 2-in. (51 mm) beyond the unit casing on the 2 sides. The duct connection side and condensate drain connection sides should be flush with the edge of the flat surface. A concrete pad or a suitable fiberglass mounting pad is recommended.

A 6-in. (152 mm) wide gravel apron should be used around the flat surface to prevent airflow blockage by grass or shrubs. Do not secure the unit to the flat surface except where required by local codes.

The unit should be level to within 1/4 in. (6 mm). This is necessary for the unit drain to function properly.

### Step 3 — Provide Clearances

The required minimum service clearances and clearances to combustibles are shown in Fig. 2-4. Adequate ventilation and condenser air must be provided.

The condenser fan pulls air through the condenser coil and discharges it through the fan on the top cover. Be sure that the fan discharge does not recirculate to the condenser coil. Do not locate the unit in either a corner or under an overhead obstruction. The minimum clearance under a partial overhang (such as a normal house overhang) is 48 in. (1219 mm) above the unit top. The maximum horizontal extension of a partial overhang must not exceed 48 in. (1219 mm).

Do not place the unit where water, ice, or snow from an overhang or roof will damage or flood the unit. The unit may be installed on wood flooring or on Class A, B, or C roof covering materials.

### Step 4 — Place Unit

Unit can be moved with the handholds provided in the unit basepan. Refer to Table 1 for operating weights. Use extreme caution to prevent damage when moving the unit. Unit must remain in an upright position during all moving operations. The unit must be level for proper condensate drainage; the ground-level pad must be level before setting the unit in place. When a field-fabricated support is used, be sure that the support is level and that it properly supports the unit.

### Step 5 — Select and Install Ductwork

The design and installation of the duct system must be in accordance with:

- the standards of the NFPA (National Fire Protection Association) for installation of nonresidence-type air conditioning and ventilating systems;
- NFPA90A or residence-type, NFPA90B; and/or local codes and residence-type, NFPA 90B;
- and/or local codes and ordinances.

Select and size ductwork, supply-air registers and return-air grilles according to ASHRAE (American Society of Heating, Refrigeration, and Air Conditioning Engineers) recommendations.

Use the duct flanges provided on the supply- and return-air openings on the side of the unit. See Fig. 2-4 for connection sizes and locations. The 14-in. (356 mm) round duct collars (size 036-048 units) are shipped inside the unit attached to the indoor blower. They are field-installed and must be removed from the indoor cavity prior to start-up, even if they are not used for installation.

**INSTALL FLANGES FOR DUCTWORK CONNECTIONS (50ZP060 ONLY)** — The 50ZP060 units are shipped with flanges which must be field-installed on the unit.

To install unit flanges:

1. Five pieces of flange are shipped on the return-air opening of the unit. Remove the flanges from the shipping position. See Fig. 5. Screws are field-supplied.
2. One piece of flange is used as it is shipped (straight). Bend the other 4 pieces at right angles.
3. Install the straight flange on the right side of the return-air opening in holes provided. See Fig. 6. Flanges should stick out from unit to allow for connection of ductwork.
4. Install 2 hand-formed flanges onto return air opening in holes provided to form a rectangle around the return air opening.
5. Install remaining 2 hand-formed flanges around discharge air opening in holes provided.
6. Ductwork can now be attached to flanges.

When designing and installing ductwork, consider the following:



## CAUTION

### UNIT DAMAGE HAZARD

Failure to follow this caution may result in damage to unit components.

When connecting ductwork to units, do not drill deeper than 3/4 in. (19.1 mm) in shaded area shown in Fig. 7 or coil may be damaged.

• All units should have field-supplied filters installed in the return-air side of the unit. Recommended sizes for filters are shown in Table 1.

• Avoid abrupt duct size increases and reductions. Abrupt change in duct size adversely affects air performance. Use flexible connectors between ductwork and unit to prevent transmission of vibration. Use suitable gaskets to ensure weathertight and airtight seal.

- Size ductwork for cooling air quantity (CFM).
- Insulate and weatherproof all external ductwork. Insulate and cover with a vapor barrier all ductwork passing through conditioned spaces. Follow latest Sheet Metal and Air Conditioning Contractors National Association (SMACNA) and Air Conditioning Contractors Association (ACCA) minimum installation standards for residential heating and air conditioning systems.
- Secure all ducts to building structure. Flash, weatherproof, and vibration-isolate duct openings in wall or roof according to good construction practices.

Fig. 8 shows a typical duct system with 50ZP unit installed.

50ZP

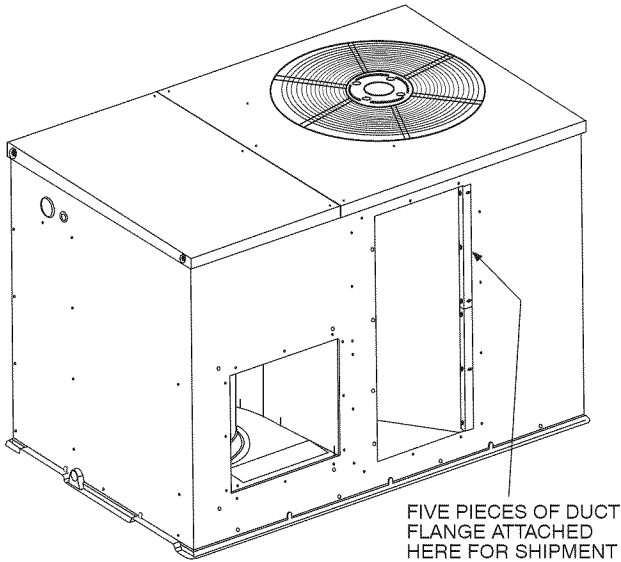

FIVE PIECES OF DUCT FLANGE ATTACHED HERE FOR SHIPMENT

C00005

Fig. 5 - Shipping Location of Duct Flanges (Size 060 Only)

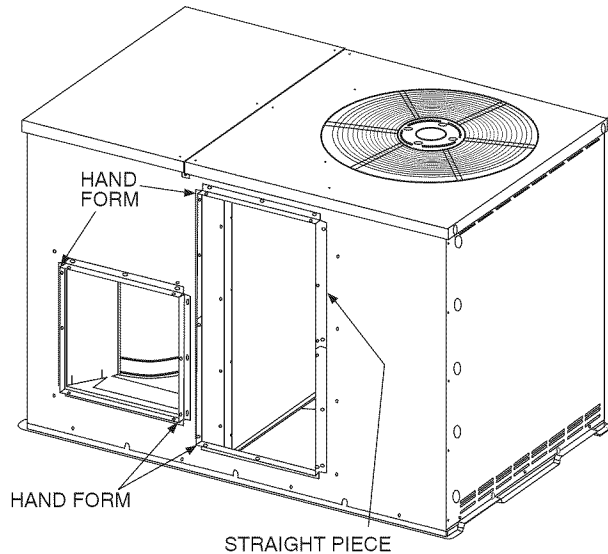

C00006

Fig. 6 - Flanges Installed on 50ZP060 Units

## Converting Horizontal Discharge Units to Downflow (Vertical) Discharge

### ⚠ WARNING

#### ELECTRICAL SHOCK HAZARD

Failure to follow this warning could result in personal injury or death.

Before performing service or maintenance operations on the system, turn off main power to unit and install lockout tag. There may be more than one disconnect switch.

Units are dedicated side supply products. They are not convertible to vertical air supply. A field-supplied plenum must be used to convert to vertical air discharge.

#### Step 6 — Charging Unit

Unit is shipped with a nitrogen holding charge only. Slowly release nitrogen charge from unit using service gages and using a vacuum pump evacuate unit to 500 microns or lower. To locate charging ports, remove top panel which provides access to control box and blower. Charging ports are located under top panel. Charge unit by weight using an electronic scale. R-22 charge quantity can be found in table 1 and on unit rating plate. Do not over charge.

#### Step 7 — Provide for Condensate Disposal

**NOTE:** Be sure that condensate-water disposal methods comply with local codes, restrictions, and practices.

Unit removes condensate through a 1-3/64 -in. (26.6 mm) ID hole which is located at the end of the unit. See Fig. 2-4 for location of condensate connection.

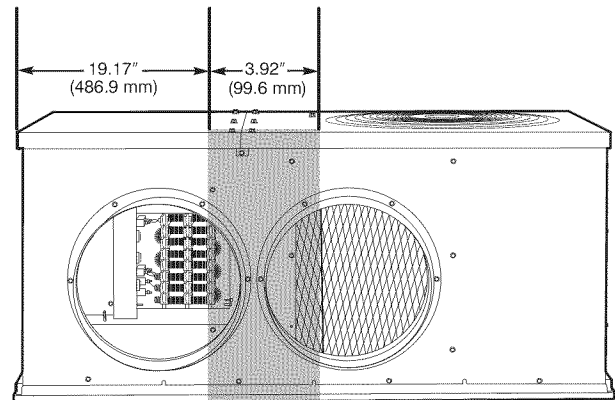

C00007

Fig. 7 - Area Not to Be Drilled More Than 3/4-in.

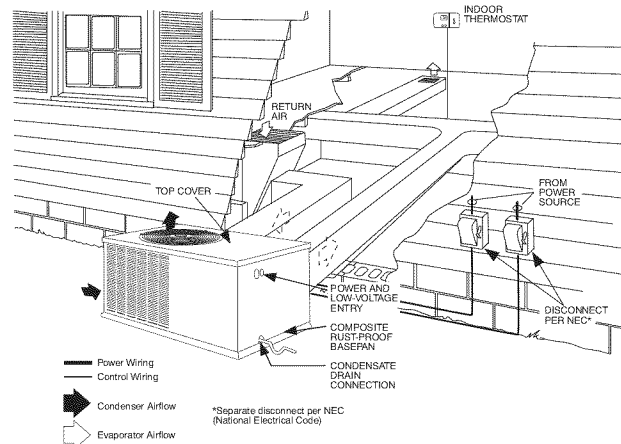

A10018

Fig. 8 - Typical Installation

**Table 1 – Physical Data**

| UNIT 50ZP   | 036                               | 048       | 060           |
|---|-----------------------------------|-----------|---------------|
| <b>SHIPPING WEIGHT (lbs)</b>                        | 278                               | 352       | 388           |
| <b>(kg)</b>   | 126                               | 160       | 176           |
| <b>COMPRESSOR TYPE</b>                              | Reciprocating                     | Scroll    | Reciprocating |
| <b>REFRIGERANT</b>                                  | R-22                              |           |               |
| <b>Charge (lb)</b>                                  | 4.2                               | 5.5       | 6.9           |
| <b>(kg)</b>   | 1.9                               | 2.5       | 3.1           |
| <b>REFRIGERANT METERING DEVICE</b>                  | Acutrol™ Device                   | Piston    |               |
| <b>CONDENSER COIL</b>                               | Copper Tubes, Aluminum Plate Fins |           |               |
| <b>Rows...Fins/in.</b>                              | 2...17                            | 2...17    | 2...17        |
| <b>Face Area (sq ft)</b>                            | 6.2                               | 8.6       | 10.7          |
| <b>CONDENSER-FAN MOTOR CFM</b>                      | 2000                              | 2600      | 2800          |
| <b>Nominal Rpm</b>                                  | 1100                              | 1100      | 1100          |
| <b>Motor Hp</b>                                     | 1/4                               | 1/4       | 1/4           |
| <b>Diameter (in.)</b>                               | 20                                | 20        | 20            |
| <b>(mm)</b>   | 508                               | 508       | 508           |
| <b>EVAPORATOR COIL</b>                              | Copper Tubes, Aluminum Plate Fins |           |               |
| <b>Rows...Fins/in.</b>                              | 3...15                            | 3...15    | 4...15        |
| <b>Face Area (sq ft)</b>                            | 3.1                               | 4.3       | 4.9           |
| <b>EVAPORATOR FAN MOTOR Blower Motor Size (in.)</b> | Direct Drive                      |           |               |
| <b>(mm)</b>   | 10x8                              | 10x9      | 10x10         |
| <b>Nominal CFM</b>                                  | 254 x 203                         | 254 x 229 | 254 x 254     |
| <b>Rpm Range</b>                                    | 1200                              | 1650      | 1700          |
| <b>Number of Speeds</b>                             | 800-1050                          | 1000-1100 | 950-1100      |
| <b>Factory Speed Setting</b>                        | 3                                 | 2         | 3             |
| <b>Motor Hp</b>                                     | Low                               | Low       | Low           |
|   | 1/2                               | 3/4       | 1             |
| <b>CONNECTING DUCT SIZES</b>                        | Round                             |           | Square        |
| <b>Supply Air (in.)</b>                             | 14                                |           | 13.9 x 13.9   |
| <b>(mm)</b>   | 356                               |           | 353 x 353     |
| <b>Return Air (in.)</b>                             | 14                                |           | 13.9 x 27.8   |
| <b>(mm)</b>   | 356                               |           | 353 x 706     |
| <b>FIELD-SUPPLIED RETURN-AIR FILTER†</b>            |                                   |           |               |
| <b>Throwaway (in.)</b>                              | 24 x 24                           | 24 x 30   |               |
| <b>(mm)</b>   | 610 x 610                         | 610 x 762 |               |

†Required filter sizes shown are based on the AHRI (Air Conditioning, Heating and Refrigeration Institute) rated airflow at a velocity of 300 ft/min for throwaway type or 450 ft/min for high capacity type. Recommended filters are 1–in. (25 mm) thick.

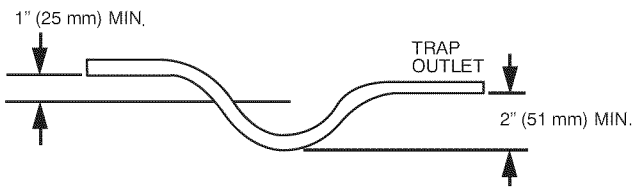

**Condensate Trap (Using Tubing)**

A08001

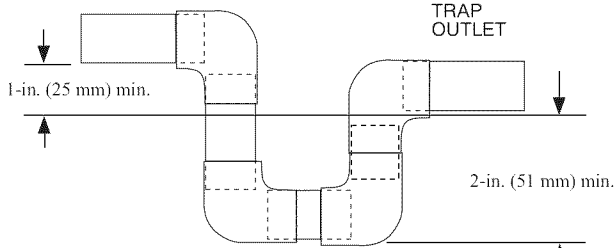

**Condensate Trap (Using PVC Piping)**  
**Fig. 9 - Condensate Trap**

A09052

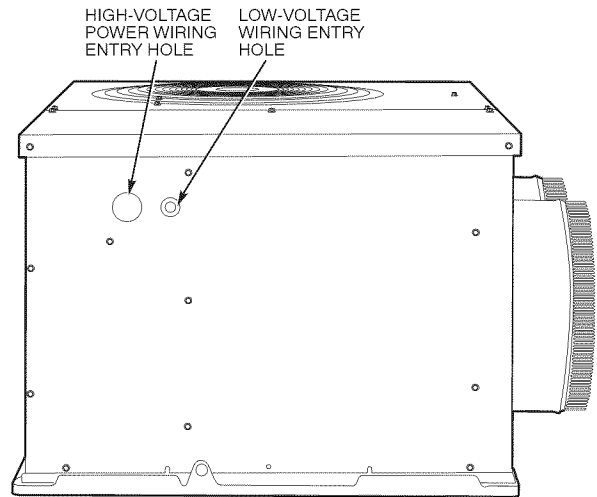

**Fig. 10 - Unit Electrical Connection Entry Holes**

C00010

**50ZP**

Condensate water can be drained directly onto the roof in rooftop installations (where permitted) or onto a gravel apron in ground level installations. Install a field-supplied condensate trap at end of condensate connection to ensure proper drainage. Make sure that the outlet of the trap is at least 1 in. (25 mm) lower than the drain-pan condensate connection to prevent the pan from overflowing. See Fig. 9. Prime the trap with water. When using a gravel apron, make sure it slopes away from the unit.

If the installation requires draining the condensate water away from the unit, install a 2-in. (51 mm) trap using a 3/4 -in. OD tubing or pipe. See Fig. 9. Make sure that the outlet of the trap is at least 1 in. (25 mm) lower than the unit drain-pan condensate connection to prevent the pan from overflowing. Prime the trap with water. Connect a drain tube using a minimum of 3/4 -in. PVC, 3/4 -in. CPVC, or 3/4 -in. copper pipe (all field supplied). Do not undersize the tube. Pitch the drain tube downward at a slope of at least 1 in. (25 mm) for every 10 ft (3 m) of horizontal run. Be sure to check the drain tube for leaks. Prime trap at the beginning of the cooling season start-up. Allowable glues for condensate trap connection are: Standard ABS, CPVC, or PVC cement.

## Step 8 — Install Electrical Connections

### ⚠ WARNING

#### ELECTRICAL SHOCK HAZARD

Failure to follow this warning could result in personal injury or death.

The unit cabinet must have an uninterrupted, unbroken electrical ground to minimize the possibility of personal injury if an electrical fault should occur. This ground may consist of an electrical wire connected to the unit ground screw in the control compartment, or conduit approved for electrical ground when installed in accordance with NEC, ANSI/NFPA 70 American National Standards Institute/National Fire Protection Association (latest edition) (in Canada, Canadian Electrical Code CSA C22.1) and local electrical codes.

### ⚠ CAUTION

#### UNIT COMPONENT DAMAGE HAZARD

Failure to follow this caution may result in damage to the unit being installed.

1. Make all electrical connections in accordance with NEC ANSI/NFPA 70 (latest edition) and local electrical codes governing such wiring. In Canada, all electrical connections must be in accordance with CSA standard C22.1 Canadian Electrical Code Part 1 and applicable local codes. Refer to unit wiring diagram.
2. Use only copper conductor for connections between field-supplied electrical disconnect switch and unit. **DO NOT USE ALUMINUM WIRE.**
3. Be sure that high-voltage power to unit is within operating voltage range indicated on unit rating plate. On 3-phase units, ensure phases are balanced within 2 percent. Consult local power company for correction of improper voltage and/or phase imbalance.
4. Do not damage internal components when drilling through any panel to mount electrical hardware, conduit, etc.

**HIGH-VOLTAGE CONNECTIONS** — The unit must have a separate electrical service with a field-supplied, waterproof disconnect switch mounted at, or within sight from the unit. Refer

to the unit rating plate for maximum fuse/circuit breaker size and minimum circuit amps (ampacity) for wire sizing.

The field-supplied disconnect may be mounted on the unit over the high-voltage inlet hole. See Fig. 2-4.

Operation of unit on improper line voltage constitutes abuse and may cause unit damage that could affect warranty.

**ROUTING POWER LEADS INTO UNIT** — Use only copper wire between disconnect and unit. The high-voltage leads should be in a conduit until they enter the unit; conduit termination at the unit must be watertight. Run the high-voltage leads through the hole on the control box side of the unit (see Fig. 10 for location). When the leads are inside the unit, run leads to the control box (Fig. 11). For single-phase units, connect leads to the black and yellow wires; for 3-phase units, connect the leads to the black, yellow, and blue wires (see Fig. 12).

**CONNECTING GROUND LEAD TO UNIT GROUND** — Refer to Fig. 11 and 12. Connect the ground lead to the chassis using the unit ground lug in the control box.

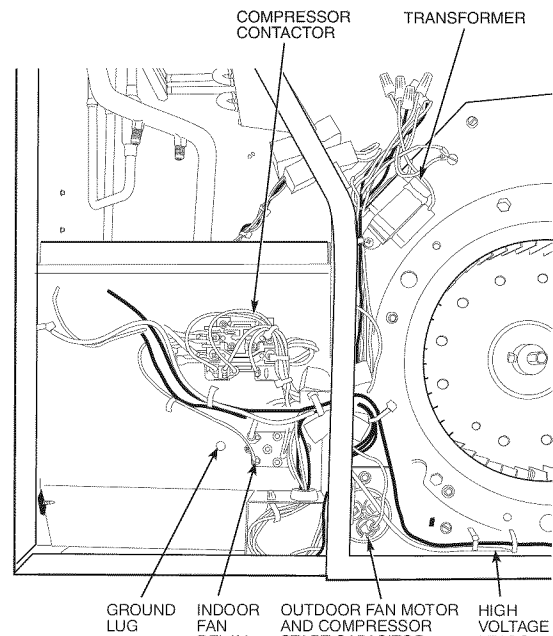

Fig. 11 - Control Box Wiring

A10019

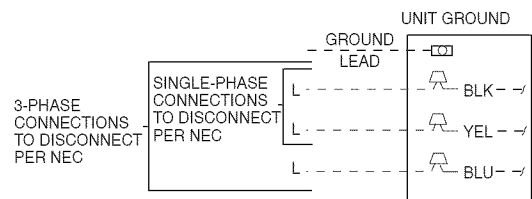

Fig. 12 - Line Power Connections

C00012

**ROUTING CONTROL POWER WIRES** — Form a drip-loop with the thermostat leads before routing them into the unit. Route the thermostat leads through grommeted hole provided in unit (see Fig. 10) into unit control box. Connect thermostat leads to unit control power leads as shown in Fig. 13.

Route thermostat wires through grommet providing a drip-loop at the panel. Connect low-voltage leads to the thermostat as shown in Fig. 13.

The unit transformer supplies 24-v power for complete system. Transformer is factory wired for 230-v operation. If supply voltage is 208 v, rewire transformer primary as described in the Special Procedures for 208-v Operation section below.



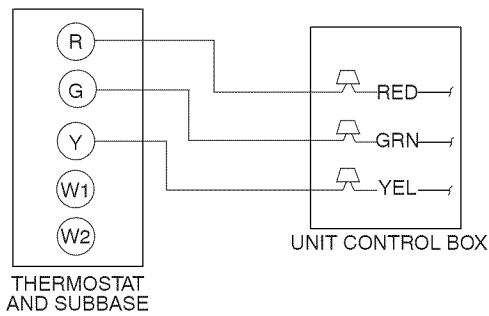

**Fig. 13 - Control Connections**

C00013

**SPECIAL PROCEDURES FOR 208-V OPERATION**

**⚠ WARNING**

**ELECTRICAL SHOCK HAZARD**

Failure to follow this warning could result in personal injury or death.

Before performing service or maintenance operations on the system, turn off main power to unit and install lockout tag. There may be more than one disconnect switch.

1. Remove wrenut from connection of ORG wire to BLK wire. Disconnect the ORG transformer-primary lead from the BLK wire. Save wrenut. See unit wiring label.
2. Remove the wrenut from the terminal on the end of the RED transformer-primary lead.
3. Save the wrenut.
4. Connect the RED lead to the BLK wire from which the ORG lead was disconnected. Insulate with wrenut from Step 1.
5. Using the wrenut removed from the RED lead, insulate the loose terminal on the ORG lead.
6. Wrap the wrenuts with electrical tape so that the metal terminals cannot be seen.

Indoor blower-motor speeds may need to be changed for 208-v operation. Refer to Indoor Airflow and Airflow Adjustments section.

**PRE-START-UP**

**⚠ WARNING**

**FIRE, EXPLOSION, ELECTRICAL SHOCK HAZARD**

Failure to follow this warning could result in personal injury or death and/or property damage.

1. Follow recognized safety practices and wear protective goggles when checking or servicing refrigerant system.
2. Relieve and recover all refrigerant from system before touching or disturbing anything inside terminal box if refrigerant leak is suspected around compressor terminals.
3. Never attempt to repair soldered connection while refrigerant system is under pressure.
4. Do not use torch to remove any component. System contains oil and refrigerant under pressure.
5. To remove a component, wear protective goggles and proceed as follows:
  - a. Shut off electrical power to unit and install lockout tag.
  - b. Relieve and reclaim all refrigerant from system using both high- and low-pressure ports.
  - c. Cut component connecting tubing with tubing cutter and remove component from unit.
  - d. Carefully unsweat remaining tubing stubs when necessary. Oil can ignite when exposed to flame.

**502P**

Use the Start-Up Checklist supplied at the end of this book and proceed as follows to inspect and prepare the unit for initial start-up:

1. Remove all access panels.
2. Read and follow instructions on all DANGER, WARNING, CAUTION, and INFORMATION labels attached to, or shipped with, unit. Make the following inspections:
  - a. Inspect for shipping and handling damages such as broken lines, loose parts, disconnected wires, etc.
  - b. Inspect for oil at all refrigerant tubing connections and on unit base. Detecting oil generally indicates a refrigerant leak. Leak-test all refrigerant tubing connections using electronic leak detector, or liquid-soap solution. If a refrigerant leak is detected, see following Check for Refrigerant Leaks section.
  - c. Inspect all field- and factory-wiring connections. Be sure that connections are completed and tight.
  - d. Inspect coil fins. If damaged during shipping and handling, carefully straighten fins with a fin comb.
3. Verify the following conditions:
  - a. Make sure that outdoor-fan blade is correctly positioned in fan orifice. Top edge of blade should be 3.125 in. (79.4 mm) down from condenser outlet grille. See Condenser Fan section.
  - b. Make sure that air filter is in place.
  - c. Make sure that condensate drain pan and trap are filled with water to ensure proper drainage.
  - d. Make sure that all tools and miscellaneous loose parts have been removed.

## START-UP

Use the Start-Up Checklist supplied at the end of this book, and proceed as follows:

### Step 1 — Check for Refrigerant Leaks

LOCATE AND REPAIR REFRIGERANT LEAKS AND CHARGE THE UNIT AS FOLLOWS:

1. Using both high- and low-pressure ports, locate leaks and reclaim remaining refrigerant to relieve system pressure.
2. Repair leak following accepted practices.

**NOTE:** Install a filter drier whenever the system has been opened for repair.

3. Check system for leaks using an approved method.
4. Evacuate refrigerant system and reclaim refrigerant if no additional leaks are found.
5. Charge unit with R-22 refrigerant, using a volumetric-charging cylinder or accurate scale. Refer to unit rating plate for required charge. Be sure to add extra refrigerant to compensate for internal volume of field-installed filter drier.

### Step 2 — Start-Up Cooling Section and Make Adjustments

CHECKING COOLING CONTROL OPERATION — Start and check the unit for proper cooling control operation as follows:

1. Place room thermostat SYSTEM switch in OFF position. Observe that blower motor starts when FAN switch is placed in ON position and shuts down when FAN switch is placed in AUTO position.
2. Place SYSTEM switch in COOL position and FAN switch in AUTO position. Set cooling control below room temperature. Observe that compressor, condenser fan, and evaporator blower motors start. Observe that cooling cycle shuts down when control setting is satisfied.
3. When using an automatic changeover room thermostat, place both SYSTEM and FAN switches in AUTO positions. Observe that unit operates in Cooling mode when temperature control is set to “call for cooling” (below room temperature).

### Step 3 — Refrigerant Charge

Amount of refrigerant charge is listed on unit nameplate (also refer to Table 1). Refer to Carrier Refrigerant Service Techniques Manual, Refrigerants section.

Unit panels must be in place when unit is operating during charging procedure.

**NO CHARGE** — Use standard evacuating techniques. After evacuating system, weigh in the specified amount of refrigerant (refer to Table 1).

**LOW CHARGE COOLING** — Use Cooling Charging Charts, Fig. 14-16. Vary refrigerant until the conditions of the appropriate chart are met. Note that charging charts are different from the type normally used. Charts are based on charging the units to the correct superheat for the various operating conditions. Accurate pressure gage and temperature sensing device are required.

To measure suction pressure, perform the following:

1. Connect the pressure gage to the service port on the suction line.
2. Mount the temperature sensing device on the suction line and insulate it so that outdoor ambient temperature does not affect the reading. Indoor-air cfm must be within the normal operating range of the unit.

### TO USE COOLING CHARGING CHARTS

1. Take the outdoor ambient temperature and read the suction pressure gage.
2. Refer to appropriate chart to determine what the suction temperature should be.
3. If suction temperature is high, add refrigerant. If suction temperature is low, carefully recover some of the charge.
4. Recheck the suction pressure as charge is adjusted.

**EXAMPLE:** (Fig. 14)

Outdoor Temperature .....85°F (29°C)

Suction Pressure .....80 psig

Suction Temperature should be .....70°F (21°C)

(Suction Temperature may vary  $\pm 5^\circ\text{F}$  [2.8°C])

If Chargemaster® charging device is used, temperature and pressure readings must be accomplished using the charging chart.

### Step 4 — Indoor Airflow and Airflow Adjustments

**NOTE:** For cooling operation, the recommended airflow is 350 to 450 CFM for each 12,000 Btuh of rated cooling capacity.

Table 2 shows dry coil air delivery for horizontal discharge units. Tables 3-4 show pressure drops.

**NOTE:** Be sure that all supply- and return-air grilles are open, free from obstructions, and adjusted properly.

## ⚠ WARNING

### ELECTRICAL SHOCK HAZARD

Failure to follow this warning could result in personal injury or death.

Disconnect electrical power to the unit and install lockout tag before changing blower speed. There may be more than one disconnect switch.

Airflow can be changed by changing the lead connections of the blower motor.

Units 50ZP036,048, and 060 blower motors are factory wired for low speed operation.

**FOR 208/230-V** — The motor leads are color-coded as follows:

| 3-SPEED             | 2-SPEED            |
|---------------------|--------------------|
| black = high speed  | black = high speed |
| blue = medium speed |                    |
| red = low speed     | red = low speed    |

To change the speed of the blower motor (BM), remove the fan motor speed leg lead from the indoor (evaporator) fan relay (IFR) and replace with lead for desired blower motor speed. Insulate the removed lead to avoid contact with chassis parts.

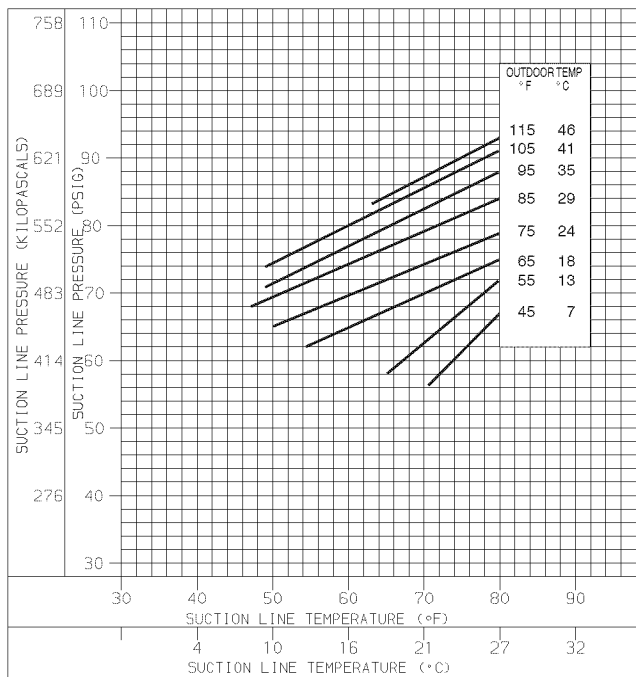

C00017

Fig. 14 - Cooling Charging Chart, 50ZP036 Units

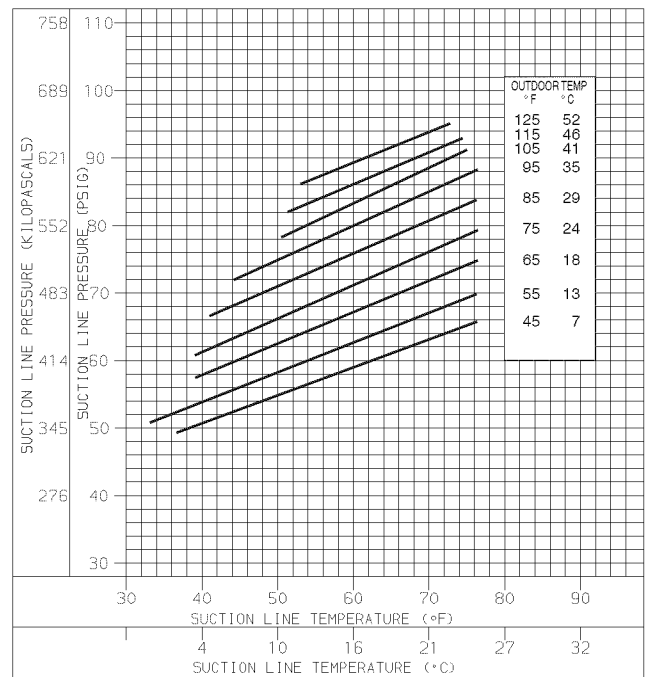

C00020

Fig. 16 - Cooling Charging Chart, 50ZP060 Units

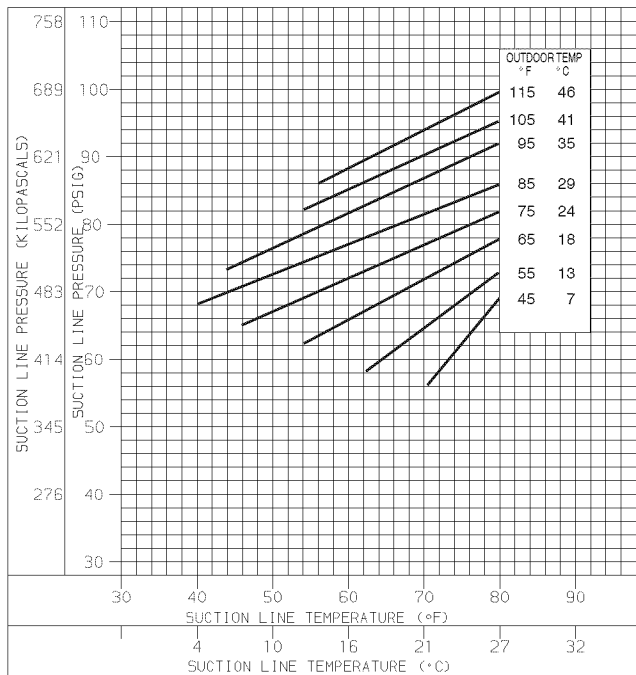

C00019

Fig. 15 - Cooling Charging Chart, 50ZP048 Units

### Step 5 — Unit Controls

All compressors have the following internal-protection controls.

**HIGH-PRESSURE RELIEF VALVE** — This valve opens when the pressure differential between the low and high side becomes excessive.

**COMPRESSOR OVERLOAD** — This overload interrupts power to the compressor when either the current or internal temperature become excessive, and automatically resets when the internal temperature drops to a safe level. This overload may require up to 60 minutes (or longer) to reset; therefore, if the internal overload is suspected of being open, disconnect the electrical power to the unit and check the circuit through the overload with an ohmmeter or continuity tester.

### Step 6 — Sequence of Operation

**FAN OPERATION** — The FAN switch on the thermostat controls indoor fan operation. When the FAN switch is placed in the ON position, the IFR (indoor-fan relay) is energized through the G terminal on the thermostat. The normally-open contacts close, which then provide power to the indoor (evaporator) fan motor (IFM). The IFM will run continuously when the FAN switch is set to ON.

When the FAN switch is set to AUTO, the thermostat deenergizes the IFR (provided there is not a call for cooling). The contacts open and the IFM is deenergized. The IFM will be energized only when there is a call for cooling.

**NOTE:** Units are equipped with a time-delay relay. The indoor fan remains on for 30 seconds after G or Y is deenergized.

**COOLING** — On a call for cooling, the compressor contactor (C) and the IFR are energized through the Y and G terminals of the thermostat. On units with a compressor time-delay relay, there is a 5-minute ( $\pm 45$  sec) delay between compressor starts. Energizing the compressor contactor supplies power to the compressor and the outdoor (condenser) fan motor (OFM). Energizing the IFR provides power to the IFM.

When the need for cooling has been satisfied, the OFM, compressor, and IFM (FAN on AUTO) are deenergized. If the unit is equipped with a 30-second delay, the indoor fan will remain energized for 30 seconds after the compressor is deenergized (030 and 060 units only).

### MAINTENANCE

To ensure continuing high performance, and to reduce the possibility of premature equipment failure, periodic maintenance must be performed on this equipment. This cooling unit should be inspected at least once each year by a qualified service person. To troubleshoot cooling of units, refer to Troubleshooting chart in back of book.

**NOTE:** TO EQUIPMENT OWNER: Consult your local dealer about the availability of a maintenance contract.

## ⚠ WARNING

### PERSONAL INJURY AND UNIT DAMAGE HAZARD

Failure to follow this warning could result in personal injury or death and possible unit component damage.

The ability to properly perform maintenance on this equipment requires certain expertise, mechanical skills, tools and equipment. If you do not possess these, do not attempt to perform any maintenance on this equipment, other than those procedures recommended in the Owner's Manual.

The minimum maintenance requirements for this equipment are as follows:

1. Inspect air filter(s) each month. Clean or replace when necessary.
2. Inspect indoor coil, outdoor coil, drain pan, and condensate drain each cooling season for cleanliness. Clean when necessary.
3. Inspect blower motor and wheel for cleanliness each cooling season. Clean when necessary.
4. Check electrical connections for tightness and controls for proper operation each cooling season. Service when necessary.
5. Check the drain channel in the top cover periodically for blockage (leaves, insects). Clean as needed.

## ⚠ WARNING

### ELECTRICAL SHOCK HAZARD

Failure to follow these warnings could result in personal injury or death:

1. Turn off electrical power and install lockout tag to the unit before performing any maintenance or service on this unit. There may be more than one disconnect switch.
2. Use extreme caution when removing panels and parts.
3. Never place anything combustible either on or in contact with the unit.

### Step 1 — Air Filter

**IMPORTANT:** Never operate the unit without a suitable air filter in the return-air duct system. Always replace the filter with the same dimensional size and type as originally installed. See Table 1 for recommended filter sizes.

Inspect air filter(s) at least once each month and replace (throwaway-type) or clean (cleanable-type) at least twice during each cooling season or whenever the filters become clogged with dust and lint.

Replace filters with the same dimensional size and type as originally provided, when necessary.

### Step 2 — Unit Top Removal (Condenser-Coil Side)

**NOTE:** When performing maintenance or service procedures that require removal of the unit top, be sure to perform all of the routine maintenance procedures that require top removal, including coil inspection and cleaning, and condensate drain pan inspection and cleaning.

## ⚠ WARNING

### ELECTRICAL SHOCK HAZARD

Failure to follow this warning could result in personal injury or death.

Disconnect electrical power, and install lockout tag to the unit before removing top. There may be more than one disconnect switch.

Only qualified service personnel should perform maintenance and service procedures that require unit top removal.

Refer to the following top removal procedures:

1. Remove 7 screws on unit top cover surface. (Save all screws.)
2. Remove 2 screws on unit top cover flange. (Save all screws.)
3. Lift top from unit carefully. Set top on edge and make sure that top is supported by unit side that is opposite duct (or plenum) side.
4. Carefully replace and secure unit top to unit, using screws removed in Steps 1 and 2, when maintenance and/or service procedures are completed.

### Step 3 — Evaporator Blower and Motor

For longer life, operating economy, and continuing efficiency, clean accumulated dirt and grease from the blower wheel and motor annually.

## ⚠ WARNING

### ELECTRICAL SHOCK HAZARD

Failure to follow this warning could result in personal injury or death.

Disconnect electrical power, and install lockout tag to the unit before cleaning and lubricating the blower motor and wheel. There may be more than one disconnect switch.

To clean the blower wheel:

1. Access the blower assembly as follows:
  - a. Remove top access panel.
  - b. Remove 3 screws that hold blower orifice ring to blower housing. Save screws.
  - c. Loosen setscrew(s) which secure wheel to motor shaft.
2. Remove and clean blower wheel as follows:
  - a. Lift wheel from housing. When handling and/or cleaning blower wheel, be sure not to disturb balance weights (clips) on blower wheel vanes.
  - b. Remove caked-on dirt from wheel and housing with a brush. Remove lint and/or dirt accumulations from wheel and housing with vacuum cleaner, using a soft brush attachment. Remove grease and oil with a mild solvent.
  - c. Reassemble blower into housing. Place upper orifice ring on blower to judge location of the blower wheel. Blower wheel should be approximately 0.2-in. (5 mm) below bottom of orifice ring when centered correctly. Be sure setscrews are tightened on motor and are not on round part of shaft.
  - d. Set upper orifice ring in place with 3 screws removed in step 1.
  - e. Replace top access panel.

## Step 4 — Condenser Coil, Evaporator Coil, and Condensate Drain Pan

Inspect the condenser coil, evaporator coil, and condensate drain pan at least once each year. Proper inspection and cleaning requires the removal of the unit top. See Unit Top Removal section above.

The coils are easily cleaned when dry; therefore, inspect and clean the coils either before or after each cooling season. Remove all obstructions (including weeds and shrubs) that interfere with the airflow through the condenser coil. Straighten bent fins with a fin comb. If coated with dirt or lint, clean the coils with a vacuum cleaner, using a soft brush attachment. Be careful not to bend the fins. If coated with oil or grease, clean the coils with a mild detergent-and-water solution. Rinse coils with clear water, using a garden hose. Be careful not to splash water on motors, insulation, wiring, or air filter(s). For best results, spray condenser-coil fins from inside to outside the unit. On units with an outer and inner condenser coil, be sure to clean between the coils. Be sure to flush all dirt and debris from the unit base.

Inspect the drain pan and condensate drain line when inspecting the coils. Clean the drain pan and condensate drain by removing all foreign matter from the pan. Flush the pan and drain tube with clear water. Do not splash water on the insulation, motor, wiring, or air filter(s). If the drain tube is restricted, clear it with a “plumbers snake” or similar probe device. Ensure that the auxiliary drain port above the drain tube is also clear.

## Step 5 — Condenser Fan



### CAUTION

#### UNIT OPERATION HAZARD

Failure to follow this caution may result in damage to unit components.

Keep the condenser fan free from all obstructions to ensure proper cooling operation. Never place articles on top of unit.

1. Shut off unit power supply.
2. Remove condenser-fan assembly (grille, motor, motor cover, and fan) by removing screws and flipping assembly onto unit top cover.
3. Loosen fan hub setscrews.
4. Adjust fan height as shown in Fig. 17.
5. Tighten setscrews.
6. Replace condenser-fan assembly.

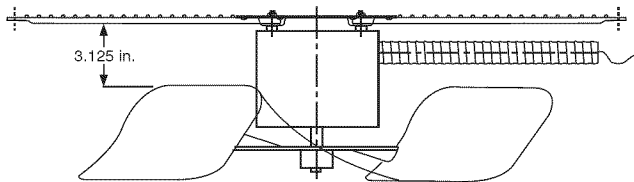

Fig. 17 - Condenser-Fan Adjustment

C00021

## Step 6 — Electrical Controls and Wiring

Inspect and check the electrical controls and wiring annually. Be sure to turn off the electrical power to the unit.

Remove the top panel to locate all the electrical controls and wiring. Check all electrical connections for tightness. Tighten all screw connections. If any smoky or burned connections are noticed, disassemble the connection, clean all the parts, restrip the wire end and reassemble the connection properly and securely.

After inspecting the electrical controls and wiring, replace all the panels. Start the unit, and observe at least one complete cooling cycle to ensure proper operation. If discrepancies are observed in operating cycle, or if a suspected malfunction has occurred, check each electrical component with the proper electrical instrumentation. Refer to the unit wiring label when making these checkouts.

**NOTE:** Refer to the Sequence of Operation section, as an aid in determining proper control operation.

## Step 7 — Refrigerant Circuit

Inspect all refrigerant tubing connections and the unit base for oil accumulations annually. Detecting oil generally indicates a refrigerant leak.

If oil is detected or if low cooling performance is suspected, leak-test all refrigerant tubing using an electronic leak-detector, or liquid-soap solution. If a refrigerant leak is detected, refer to Check for Refrigerant Leaks section.

If no refrigerant leaks are found and low cooling performance is suspected, refer to Refrigerant Charge section.

## Step 8 — Evaporator Airflow

The cooling airflow does not require checking unless improper performance is suspected. If a problem exists, be sure that all supply- and return-air grilles are open and free from obstructions, and that the air filter is clean. When necessary, refer to Indoor Airflow and Airflow Adjustments section to check the system airflow.

## Step 9 — Metering Devices

The 036 size uses fixed orifices located in the inlet header to the evaporator coil. The 048 and 060 use a single piston located in the brass body connected to the feeder tubes.

## Step 10 — Liquid Line Strainer

The liquid line strainer (to protect metering device) is made of wire mesh and is located in the liquid line on the inlet side of the metering device.

## TROUBLESHOOTING

Refer to the Troubleshooting Chart (Table 5) for troubleshooting information.

## START-UP CHECKLIST

Use the Start-Up Checklist at the back of this manual.

**Table 2 – Dry Coil Air Delivery\* Horizontal Discharge (Deduct 10% for 208 Volt Operation)**

| Unit | Motor Speed | Air Delivery | External Static Pressure (IN. W.C.) |      |      |      |      |      |      |      |      |     |
|------|-------------|--------------|-------------------------------------|------|------|------|------|------|------|------|------|-----|
|      |             |              | 0.1                                 | 0.2  | 0.3  | 0.4  | 0.5  | 0.6  | 0.7  | 0.8  | 0.9  |     |
| 036  | Low         | Watts        | 450                                 | 435  | 420  | 400  | 380  | 335  | 326  | 311  | -    |     |
|      |             | Cfm          | 1231                                | 1218 | 1204 | 1120 | 1008 | 950  | 863  | 751  | -    |     |
|      | Med         | Watts        | 470                                 | 450  | 445  | 410  | 388  | 359  | 338  | 321  | -    |     |
|      |             | Cfm          | 1302                                | 1264 | 1205 | 1163 | 1081 | 940  | 873  | 783  | -    |     |
|      | High        | Watts        | 660                                 | 635  | 610  | 575  | 540  | 505  | 485  | 460  | -    |     |
|      |             | Cfm          | 1700                                | 1660 | 1581 | 1450 | 1297 | 1190 | 1095 | 999  | -    |     |
| 048  | Low         | Watts        | -                                   | -    | 801  | 760  | 730  | 688  | 650  | 600  | 570  |     |
|      |             | Cfm          | -                                   | -    | 1898 | 1841 | 1757 | 1682 | 1564 | 1429 | 1365 |     |
|      | High        | Watts        | -                                   | -    | 870  | 842  | 818  | 782  | 696  | 632  | 628  |     |
|      |             | Cfm          | -                                   | -    | 2000 | 1903 | 1799 | 1718 | 1625 | 1446 | 1333 |     |
|      | 060         | Low          | Watts                               | 890  | 850  | 810  | 790  | 735  | 680  | 580  | 480  | 422 |
|      |             |              | Cfm                                 | 1834 | 1820 | 1791 | 1762 | 1703 | 1640 | 1415 | 1159 | 950 |
| Med  |             | Watts        | 1040                                | 1018 | 1000 | 950  | 890  | 835  | 790  | 650  | 580  |     |
|      |             | Cfm          | 2230                                | 2102 | 2025 | 1960 | 1901 | 1855 | 1752 | 1468 | 1121 |     |
| High |             | Watts        | 1073                                | 1038 | 1001 | 958  | 896  | 840  | 800  | 691  | 575  |     |
|      |             | Cfm          | 2230                                | 2202 | 2160 | 2122 | 2052 | 1926 | 1791 | 1588 | 1202 |     |

\* Air delivery values are based on operating voltage of 230 v dry coil, without filter. Deduct wet coil, filter pressure drops to obtain external static pressure available for ducting. See Tables 3–4.

**NOTES:**

1. Do not operate the unit at a cooling airflow that is less than 350 cfm for each 12,000 Btuh of rated cooling capacity. Evaporator coil frosting may occur at airflows below this point.
2. Dashes indicate portions of the table that are beyond the blower motor capacity or are not recommended.

**Table 3 – Wet Coil Pressure Drop**

| UNIT SIZE 50ZP | AIRFLOW (CFM) | PRESSURE DROP (IN. W.C.) |
|----------------|---------------|--------------------------|
| 036            | 1000          | 0.07                     |
|                | 1200          | 0.09                     |
|                | 1400          | 0.11                     |
|                | 1600          | 0.12                     |
| 048            | 1400          | 0.07                     |
|                | 1600          | 0.08                     |
|                | 1800          | 0.09                     |
| 060            | 1700          | 0.07                     |
|                | 1800          | 0.08                     |
|                | 2100          | 0.09                     |
|                | 2300          | 0.10                     |

**Table 4 – Filter Pressure Drop (IN. W.C.)**

| UNIT SIZE 50ZP | FILTER SIZE IN. (mm)   | CFM  |      |      |      |      |
|----------------|------------------------|------|------|------|------|------|
|                |                        | 1000 | 1100 | 1200 | 1300 | 1400 |
| 036            | 24 x 24<br>(610 x 610) | 0.09 | 0.09 | 0.10 | 0.11 | 0.12 |
| 048, 060       | 24 x 30<br>(610 x 762) | -    | -    | -    | 0.08 | 0.09 |

| UNIT SIZE 50ZP | FILTER SIZE IN. (mm)   | CFM  |      |      |      |      |      |      |      |      |
|----------------|------------------------|------|------|------|------|------|------|------|------|------|
|                |                        | 1500 | 1600 | 1700 | 1800 | 1900 | 2000 | 2100 | 2200 | 2300 |
| 036            | 24 x 24<br>(610 x 610) | 0.14 | 0.15 | -    | -    | -    | -    | -    | -    | -    |
| 048, 060       | 24 x 30<br>(610 x 762) | 0.10 | 0.11 | 0.12 | 0.13 | 0.14 | 0.15 | 0.16 | 0.17 | 0.18 |

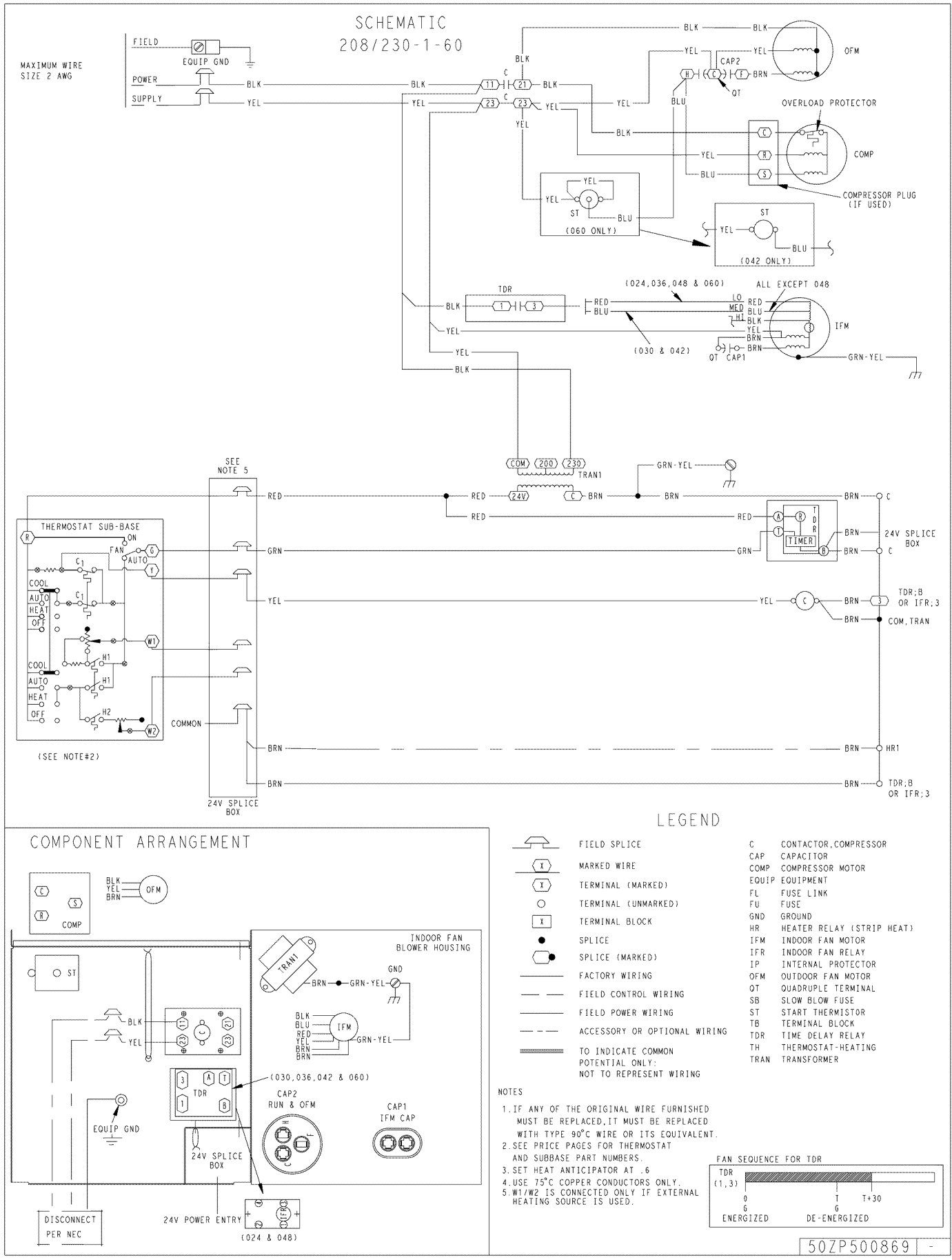

Fig. 18 - 50ZP 208/230-1 Wiring Diagram

50ZP

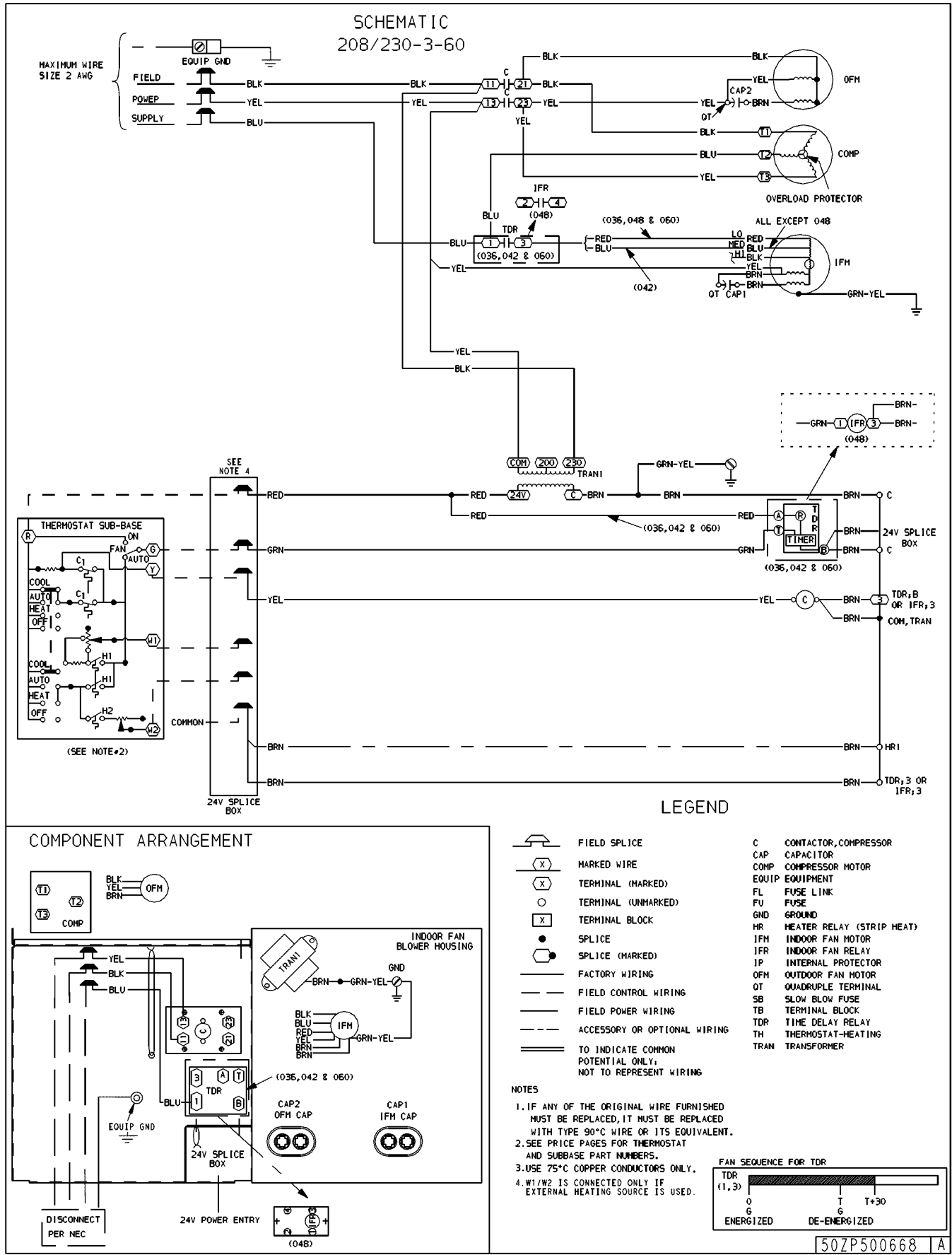

Fig. 19 - 50ZP 208/230-3 Wiring Diagram

A11578



**Table 5 – Troubleshooting Chart**

| <b>SYMPTOM</b>  | <b>CAUSE</b>  | <b>REMEDY</b>  |
|---|---|--|
| <b>Compressor and outdoor fan will not start</b>                                | Power failure   | Call power company   |
|   | Fuse blown or circuit breaker tripped   | Replace fuse or reset circuit breaker  |
|   | Defective contactor, transformer, control relay, or high-pressure, or low-pressure switch | Replace component  |
|   | Insufficient line voltage   | Determine cause and correct  |
|   | Incorrect or faulty wiring  | Check wiring diagram and rewire correctly  |
|   | Thermostat setting too low/too high   | Reset thermostat setting   |
| <b>Compressor will not start but condenser fan runs</b>                         | Faulty wiring or circuit<br>Loose connections in compressor                               | Check wiring and repair or replace   |
|   | Compressor motor burned out, seized, or internal overload open                            | Determine cause<br>Replace compressor  |
|   | Defective run capacitor, overload, or PTC (positive temperature coefficient) thermistor   | Determine cause and replace  |
|   | One leg of 3-phase power dead   | Replace fuse or reset circuit breaker<br>Determine cause                               |
|   | Low input voltage   | Determine cause and correct  |
| <b>Compressor cycles (other than normally satisfying) cooling/heating calls</b> | Refrigerant overcharge or undercharge   | Recover refrigerant, evacuate system, and recharge to capacities shown on rating plate |
|   | Defective compressor  | Replace and determine cause  |
|   | Insufficient line voltage   | Determine cause and correct  |
|   | Blocked outdoor coil  | Determine cause and correct  |
|   | Defective run/start capacitor, overload or start relay                                    | Determine cause and replace  |
|   | Faulty outdoor fan motor or capacitor   | Replace  |
|   | Restriction in refrigerant system   | Locate restriction and remove  |
| <b>Compressor operates continuously</b>   | Dirty air filter  | Replace filter   |
|   | Unit undersized for load  | Decrease load or increase unit size  |
|   | Thermostat temperature set too low  | Reset thermostat setting   |
|   | Low refrigerant charge  | Locate leak, repair, and recharge  |
|   | Air in system   | Recover refrigerant, evacuate system, and recharge                                     |
|   | Outdoor coil dirty or restricted  | Clean coil or remove restriction   |
| <b>Excessive head pressure</b>  | Dirty air filter  | Replace filter   |
|   | Dirty indoor or outdoor coil  | Clean coil   |
|   | Refrigerant overcharged   | Recover excess refrigerant   |
|   | Air in system   | Recover refrigerant, evacuate system, and recharge                                     |
|   | Indoor or outdoor air restricted or air short-cycling                                     | Determine cause and correct  |
| <b>Head pressure too low</b>  | Low refrigerant charge  | Check for leaks, repair and recharge   |
|   | Restriction in liquid tube  | Remove restriction   |
| <b>Excessive suction pressure</b>   | Refrigerant overcharged   | Recover excess refrigerant   |
| <b>Suction pressure too low</b>   | Dirty air filter  | Replace filter   |
|   | Low refrigerant charge  | Check for leaks, repair and recharge   |
|   | Metering device or low side restricted  | Remove source of restriction   |
|   | Insufficient coil airflow   | Check filter—replace if necessary  |
|   | Temperature too low in conditioned area   | Reset thermostat setting   |
|   | Outdoor ambient below 55°F (13°C)   | Install low-ambient kit  |
|   | Filter drier restricted   | Replace  |

**50ZP**

# START-UP CHECKLIST (REMOVE AND STORE IN JOB FILE)

## I. PRELIMINARY INFORMATION

Model No .....  
Serial No .....  
Date .....  
Technician .....  
Customer Information(Name/Address) .....

## II. PRE-START-UP

- Verify that all packing materials have been removed from unit.
- Verify that condensate connection is installed per installation instructions.
- Check all electrical connections and terminals for tightness.
- Check wire proximity to refrigerant tubes and sheet metal edges.
- Check that indoor (indoor) air filter is clean and in place.
- Verify that unit installation is level.
- Check fan wheel propeller for location in housing and setscrew tightness.

## III. START-UP

Supply Voltage: L1-L2 \_\_\_\_\_ L2-L3 \_\_\_\_\_ L3-L1 \_\_\_\_\_  
Compressor Amps: L1(C) \_\_\_\_\_ L2(S) \_\_\_\_\_ L3(R) \_\_\_\_\_  
Indoor Fan Amps: \_\_\_\_\_ Outdoor Fan Amps: \_\_\_\_\_

### TEMPERATURE-Cooling Mode

Outdoor Air Temperature: \_\_\_\_\_ DB \_\_\_\_\_ WB  
Return-Air Temperature: \_\_\_\_\_ DB \_\_\_\_\_ WB  
Cooling Supply Air: \_\_\_\_\_ DB \_\_\_\_\_ WB

### PRESSURES-Cooling Mode

Refrigerant Suction \_\_\_\_\_ psig  
Suction Line Temp\* \_\_\_\_\_  
Refrigerant Discharge \_\_\_\_\_ psig  
Discharge Temp† \_\_\_\_\_

\*Measured at suction inlet to compressor  
†Measured at liquid line leaving outdoor coil

50ZP