

WEIDER[®] PRO 256

www.weiderfitness.com

Sears Model No. 831.15999.3
Kmart Model No. WEBE0939.3

Serial No. _____

Write the serial number in the space above for reference.

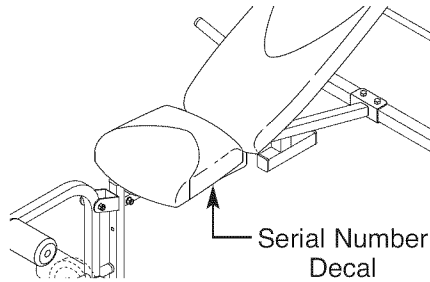

USER'S MANUAL

QUESTIONS?

If you have questions, or if parts are missing, **DO NOT CONTACT THE STORE**; please contact Customer Care.

IMPORTANT: Please register this product (see the limited warranty on the back cover of this manual) before contacting Customer Care.

SEARS CUSTOMERS:
1-800-4-MY-HOME[®]
(1-800-469-4663)

KMART CUSTOMERS:
1-877-992-5999
Mon.–Fri., 6 a.m.–6 p.m. MT
Sat. 8 a.m.–4 p.m. MT

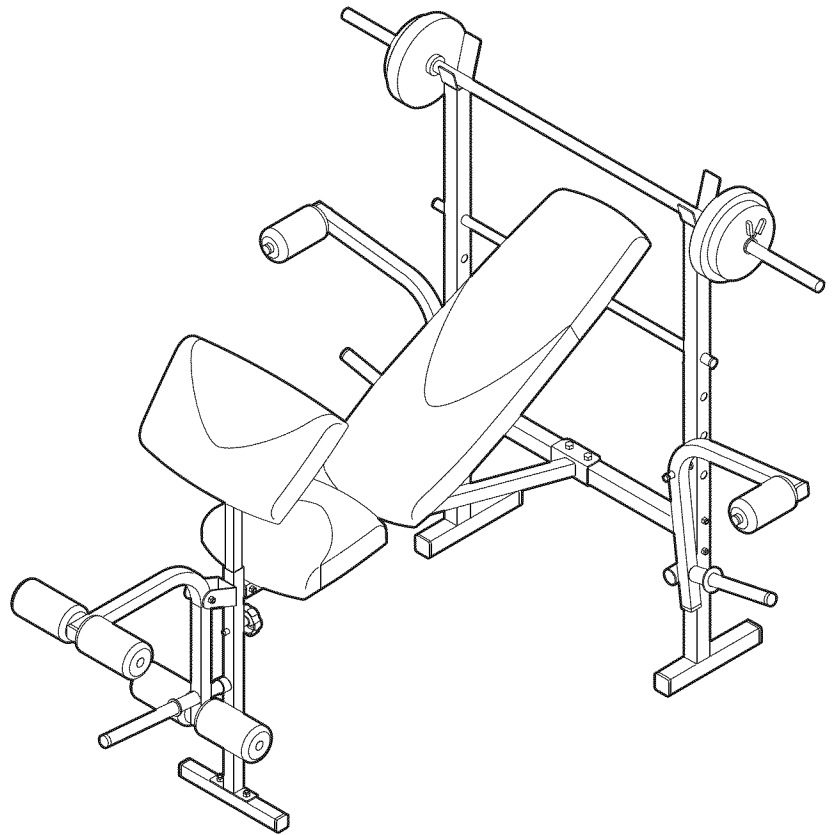

▲ CAUTION

Read all precautions and instructions in this manual before using this equipment. Keep this manual for future reference.



TABLE OF CONTENTS

WARNING DECAL PLACEMENT2

IMPORTANT PRECAUTIONS3

BEFORE YOU BEGIN4

PART IDENTIFICATION CHART5

ASSEMBLY6

ADJUSTMENT10

EXERCISE GUIDELINES12

PART LIST14

EXPLODED DRAWING15

ORDERING REPLACEMENT PARTSBack Cover

LIMITED WARRANTYBack Cover

WARNING DECAL PLACEMENT

This drawing shows the location(s) of the warning decal(s). If a decal is missing or illegible, call the telephone number on the front cover of this manual and request a free replacement decal. Apply the decal in the location shown. Note: The decal(s) may not be shown at actual size.

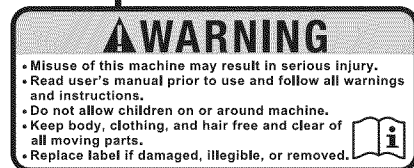
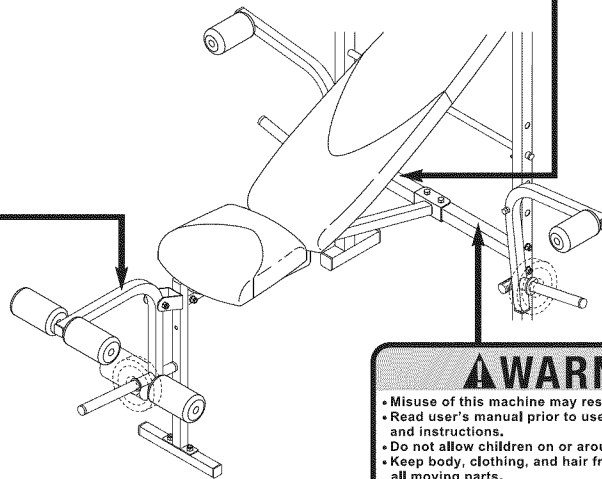

IMPORTANT PRECAUTIONS

⚠ WARNING: To reduce the risk of serious injury, read all important precautions and instructions in this manual and all warnings on your weight bench before using your weight bench. ICON assumes no responsibility for personal injury or property damage sustained by or through the use of this product.

1. Before beginning any exercise program, consult your physician. This is especially important for persons over age 35 or persons with pre-existing health problems.
2. Use the weight bench only as described in this manual.
3. It is the responsibility of the owner to ensure that all users of the weight bench are adequately informed of all precautions.
4. The weight bench is intended for home use only. Do not use the weight bench in any commercial, rental, or institutional setting.
5. Keep the weight bench indoors, away from moisture and dust. Do not put the weight bench in a garage or covered patio, or near water.
6. Place the weight bench on a level surface, with enough clearance around the weight bench to mount, dismount, and use the weight bench. To protect the floor or carpet from damage, place a mat under the weight bench.
7. Inspect and properly tighten all parts regularly. Replace any worn parts immediately.
8. Keep children under age 12 and pets away from the weight bench at all times.
9. Keep hands and feet away from moving parts.
10. Always wear athletic shoes for foot protection while using the weight bench.
11. The weight bench is designed to support a maximum user weight of 300 lbs. (136 kg), and a maximum total weight of 380 lbs. (172 kg). Do not place more than 80 lbs. (36 kg), including a barbell and weights, on the weight rests. Do not place more than 30 lbs. (14 kg) on each fly arm. Do not place more than 50 lbs. (23 kg) on the leg lever.
12. Do not use a barbell that is longer than five ft. (1.5 m) with the weight bench.
13. Always place the same amount of weight on both ends of the barbell. While adding or removing weights, always keep some weight on both ends of the barbell to prevent the barbell from tipping. Always secure weights with the spring collars.
14. Before using the leg lever, place the barbell with the same amount of weight on the weight rests to balance the bench.
15. Before using the backrest in an inclined position or a level position, make sure that the backrest support is inserted fully into the uprights and that it is turned to the locked position.
16. Over exercising may result in serious injury or death. If you feel faint or if you experience pain while exercising, stop immediately and cool down.

BEFORE YOU BEGIN

Thank you for selecting the WEIDER® PRO 256 weight bench. The versatile PRO 256 weight bench is designed to develop every major muscle group of the body. Whether your goal is to have a shapely figure, dramatic muscle size and strength, or a healthier cardiovascular system, the weight bench will help you to achieve the specific results you want.

For your benefit, read this manual carefully before using the weight bench. If you have questions after

reading this manual, please see the front cover of this manual. To help us assist you, note the product model number and serial number before contacting us. The model number and the location of the serial number decal are shown on the front cover of this manual.

Before reading further, please review the drawing below and familiarize yourself with the labeled parts.

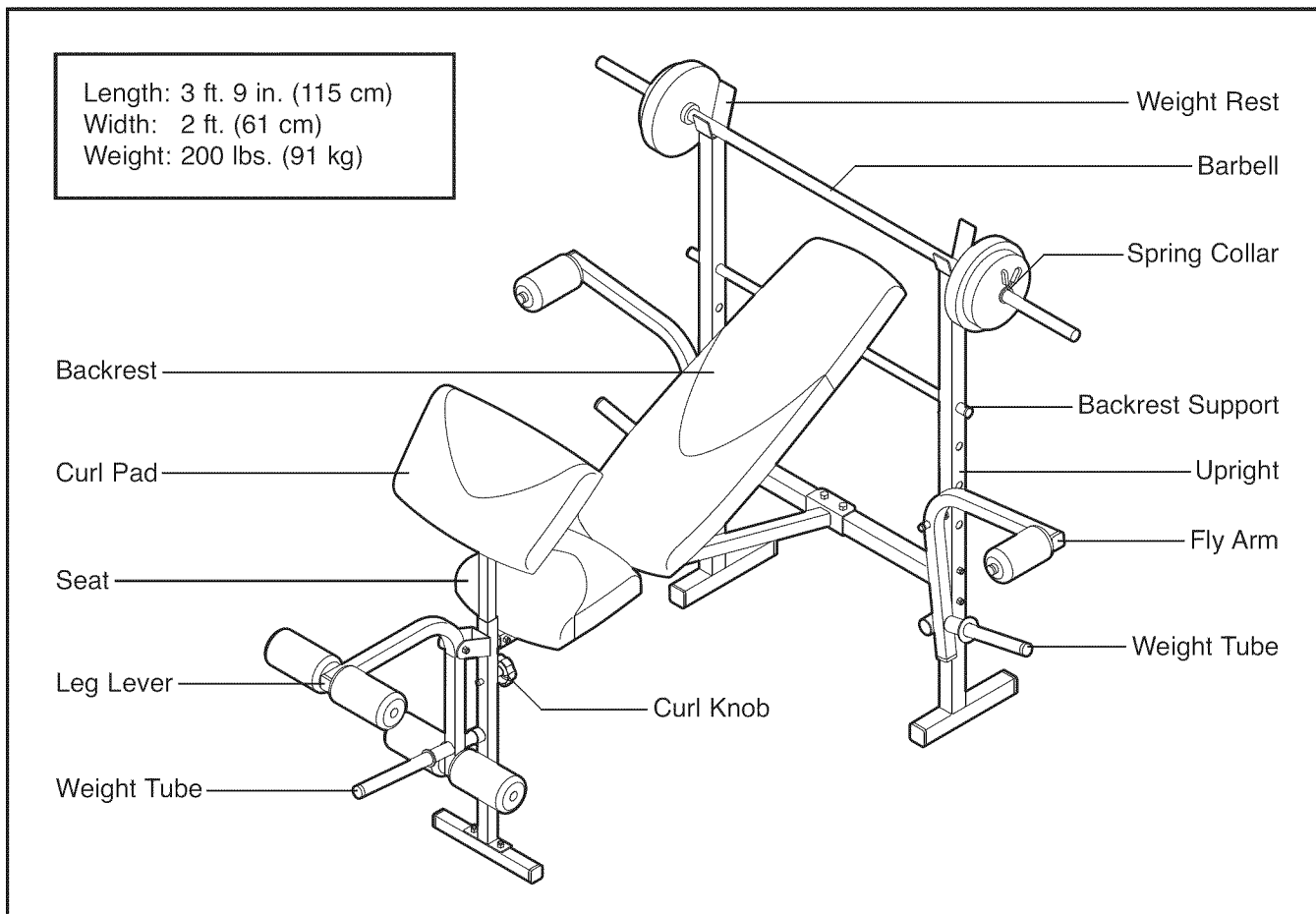

PART IDENTIFICATION CHART

See the drawings below to identify the small parts needed for assembly. The number in parentheses below each drawing is the key number of the part, from the PART LIST near the end of this manual. **Note: If a part is not in the hardware kit, check to see if it has been preassembled. To avoid damaging parts, do not use power tools for assembly.**

M10 x 137mm Bolt (36)

M10 x 120mm Bolt (19)

M10 x 63mm Bolt (32)

M8 Locknut (17)

M6 Washer (26)

M8 x 55mm Bolt (18)

M10 Locknut (33)

M8 Washer (16)

M8 x 43mm Bolt (39)

M8 x 42mm Carriage Bolt (37)

M10 Washer (34)

M6 x 38mm Screw (30)

M6 x 16mm Screw (29)

ASSEMBLY

To make assembly easier, carefully read the following assembly tips:

- Assembly requires two persons.
- Because of its weight and size, the weight bench should be assembled in the location where it will be used. Make sure that there is enough clearance to walk around the weight bench as you assemble it.
- Place all parts in a cleared area and remove the packing materials until you complete all assembly steps.

- For help identifying small parts, see page 5.
- The included grease and the following tools (not included) may be required for assembly:

Two adjustable wrenches 

One hammer 

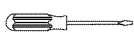
One standard screwdriver 

One Phillips screwdriver 

Assembly may be easier if you have your own set of wrenches.

1. Orient the Crossbar (3) so that the warning decals are on top.

Attach the Crossbar (3) to one of the Uprights (1) with two M8 x 55mm Bolts (18), two M8 Washers (16), and two M8 Locknuts (17); **do not tighten the Locknuts yet.**

Attach the Crossbar (3) to the other Upright (1) in the same way.

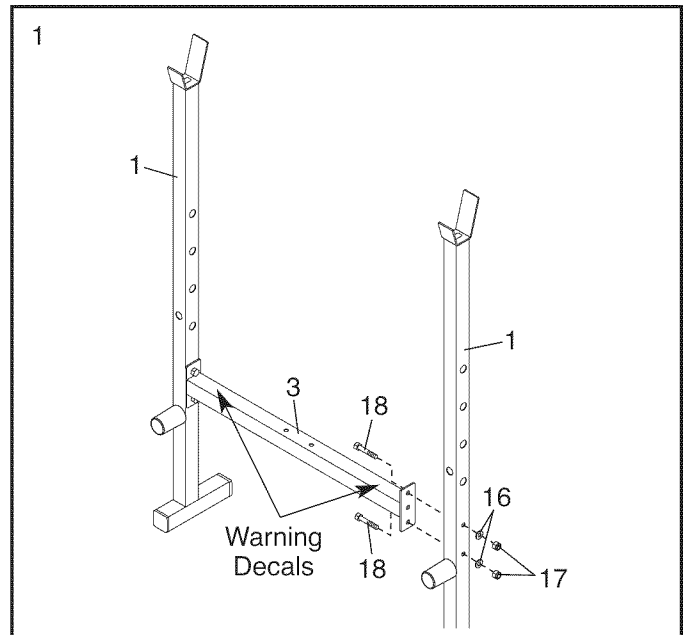

2. Orient the Stabilizer (13) so that the indented holes are facing the floor.

Attach the Stabilizer (13) to the Front Leg (8) with two M8 x 42mm Carriage Bolts (37) and two M8 Locknuts (17); **do not tighten the Locknuts yet.**

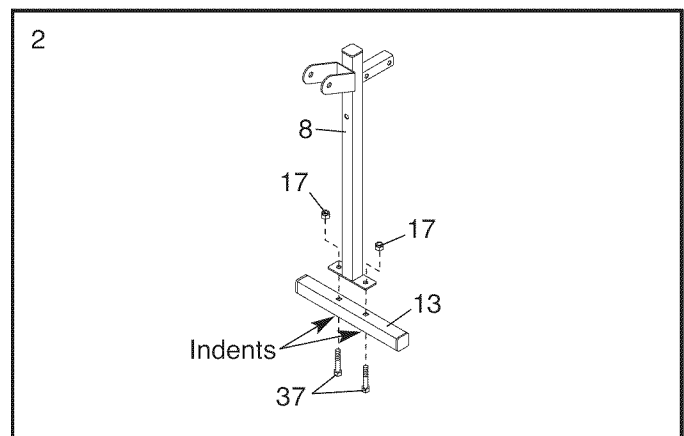

- Attach the Front Leg (8) to the Frame (2) with two M8 x 43mm Bolts (39), four M8 Washers (16), and two M8 Locknuts (17); **do not tighten the Locknuts yet.**

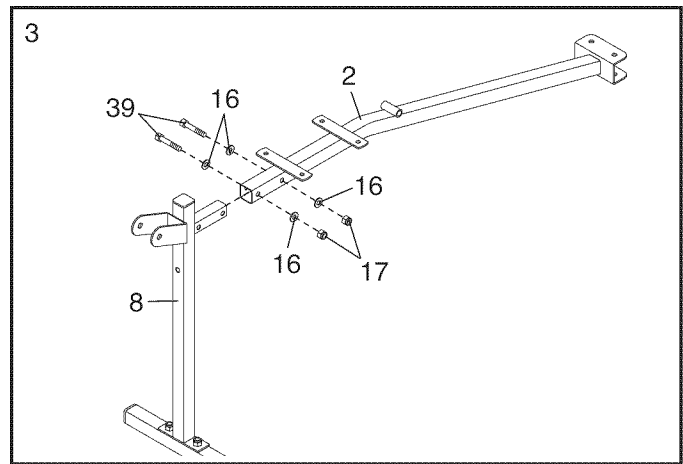

- Attach the Frame (2) to the Crossbar (3) with two M8 x 55mm Bolts (18) and two M8 Locknuts (17); **do not tighten the Locknuts yet.**

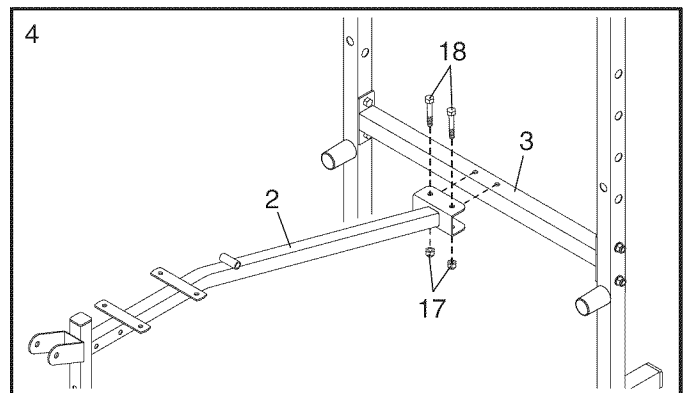

- Apply some of the included grease to an M10 x 63mm Bolt (32).

Attach the Leg Lever (4) to the Front Leg (8) with the M10 x 63mm Bolt (32) and an M10 Locknut (33). **Do not overtighten the Locknut; the Leg Lever must pivot easily.**

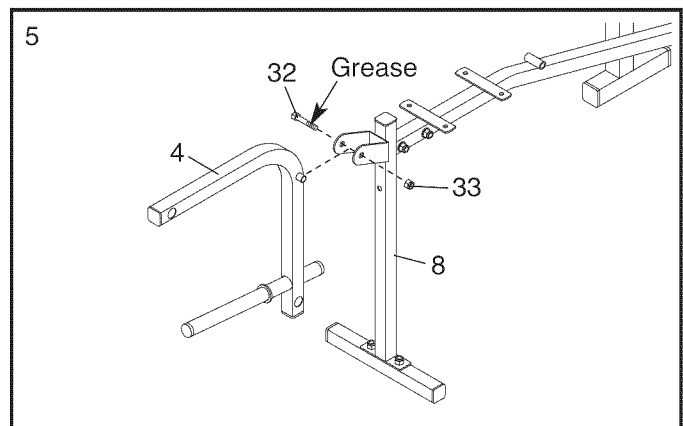

- Insert a Long Pad Tube (10) into a hole in the Leg Lever (4). Slide two Foam Pads (23) onto the Long Pad Tube.

Attach the other Long Pad Tube (10) and two Foam Pads (23) in the same way.

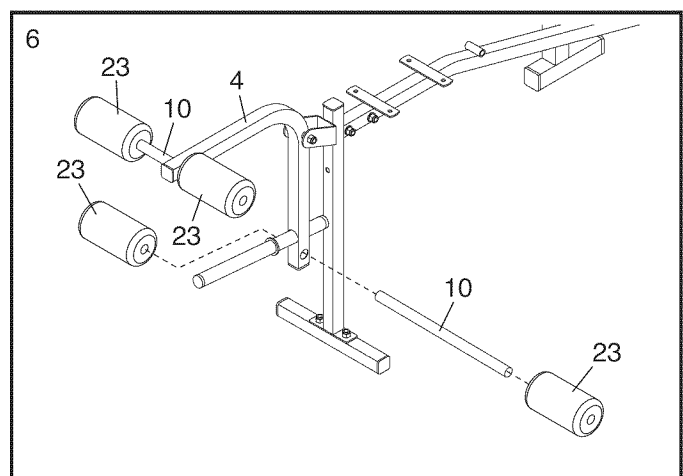

7. Orient the Backrest Tubes (5) and the Backrest (6) as shown.

Attach the Backrest Tubes (5) to the Backrest (6) with four M6 x 38mm Screws (30) and four M6 Washers (26); **do not tighten the Screws yet.**

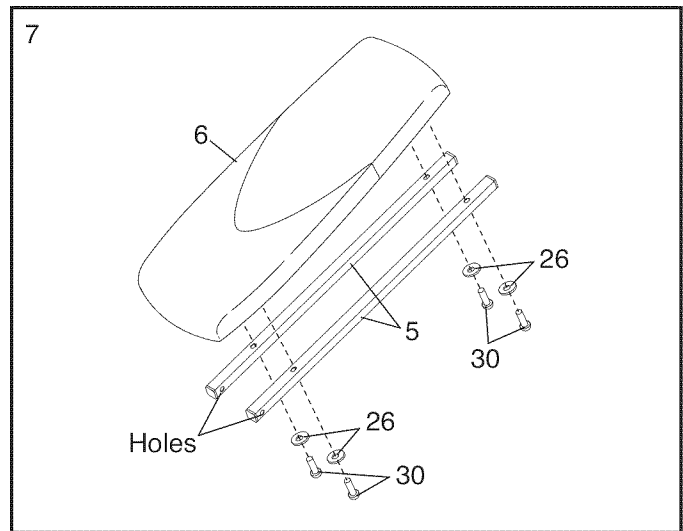

8. Insert the Backrest Support (7) into a set of holes in the Uprights (1). Rotate the Backrest Support to the locked position, with the locking pin wrapped around the left Upright.

Apply grease to an M10 x 137mm Bolt (36).

Attach the Backrest Tubes (5) to the welded tube on the Frame (2) with the M10 x 137mm Bolt (36), two M10 Washers (34), and an M10 Locknut (33). **Do not overtighten the Locknut; the Backrest Tubes must pivot easily.**

See steps 1–4. Tighten the M8 Locknuts (17).
See step 7. Tighten the M6 x 38mm Screws (30).

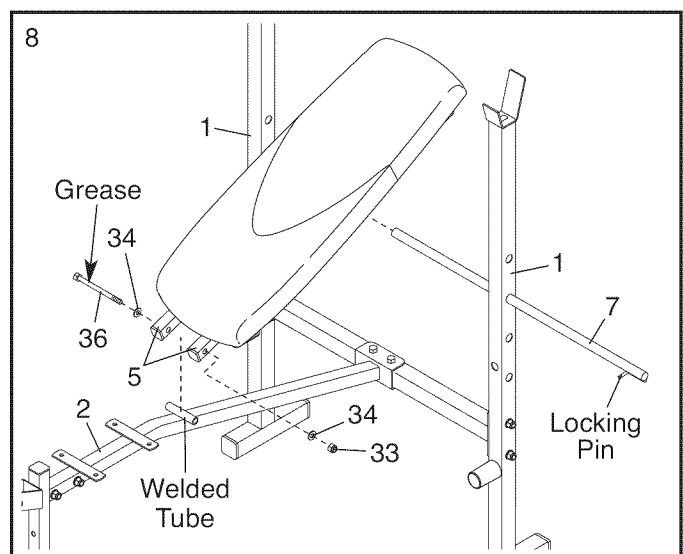

9. Attach the Seat (11) to the Frame (2) with four M6 x 16mm Screws (29).

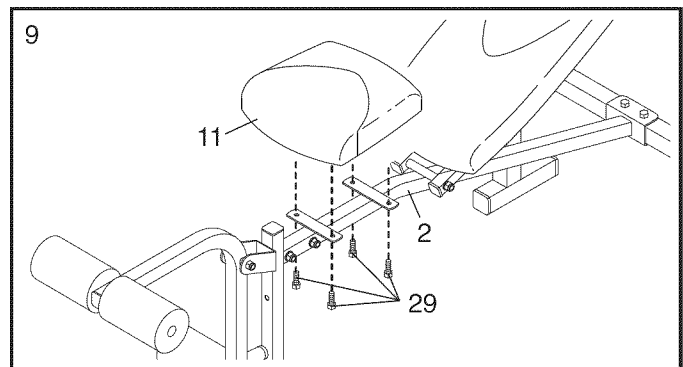

10. Slide a Weight Stop (28) onto the weight tube on a Fly Arm (25).

Slide a Weight Stop (not shown) onto the other Fly Arm (not shown) in the same way.

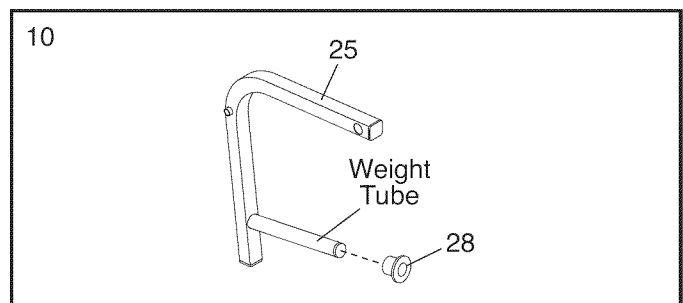

11. Attach a Fly Arm (25) to an Upright (1) with an M10 x 120mm Bolt (19) and an M10 Locknut (33). **Make sure that the Fly Arm is resting against the outer side of the Fly Arm Stop (15).** Do not overtighten the Locknut; the Fly Arm must pivot easily.

Attach the other Fly Arm (25) in the same way.

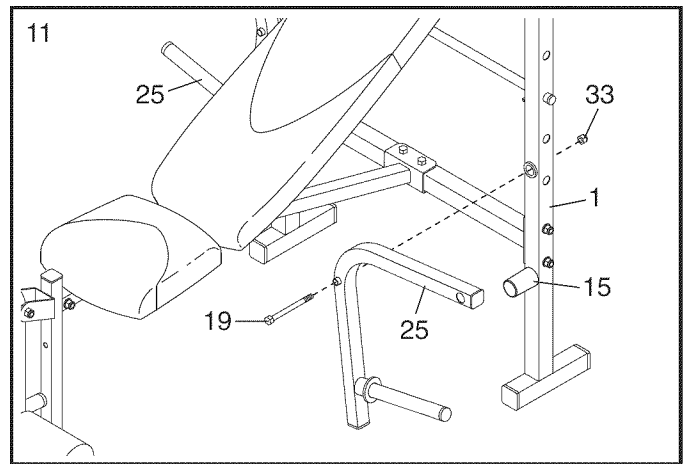

12. Insert a Short Pad Tube (12) into one of the Fly Arms (25) from the side shown. Next, slide a Foam Pad (23) onto the Short Pad Tube.

Repeat this step on the other side of the weight bench.

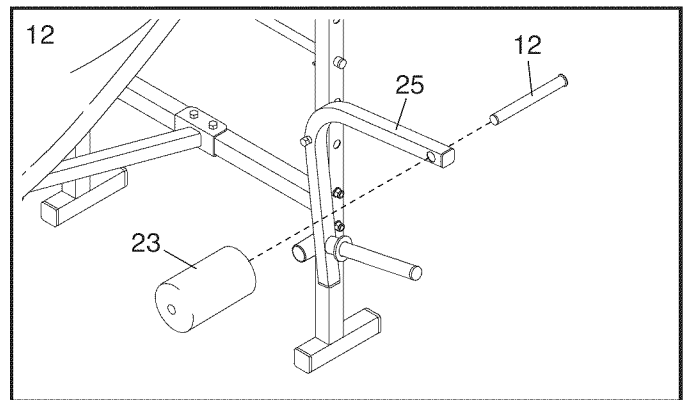

13. Attach the Curl Pad (43) to the Curl Post (27) with two M6 x 16mm Screws (29).

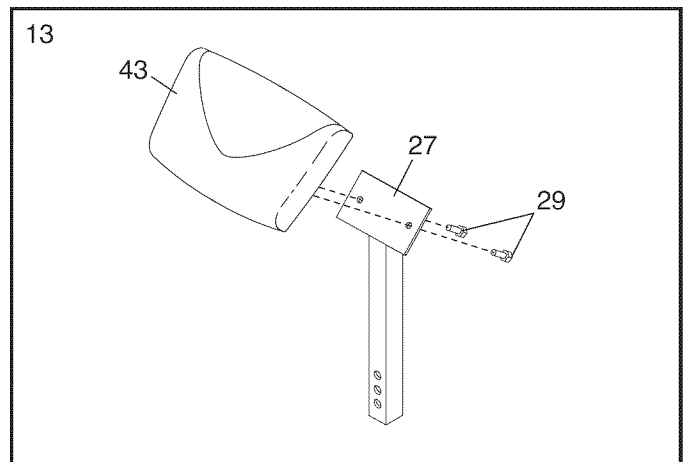

14. **Make sure that all parts are properly tightened before the weight bench is used.** Note: Some hardware may be left over after assembly is completed. The use of all remaining parts will be explained in ADJUSTMENT, beginning on page 10.

ADJUSTMENT

The steps below explain how the weight bench can be adjusted. See the accompanying exercise guide to see the correct form for several exercises.

Make sure all parts are properly tightened each time the weight bench is used. Replace any worn parts immediately. The weight bench can be cleaned with a damp cloth and a mild, non-abrasive detergent; **do not use solvents.**

ADJUSTING THE BACKREST

The Backrest (6) can be used in a declined position, a level position, or any of three inclined positions. To use the Backrest in a declined position, remove the Backrest Support (7) and lay the Backrest on the Crossbar (3).

To use the Backrest (6) in a level position or an inclined position, insert the Backrest Support (7) into a set of holes in the Uprights (1). Rotate the Backrest Support to the locked position, with the locking pin wrapped around the left Upright. Rest the Backrest on the Backrest Support.

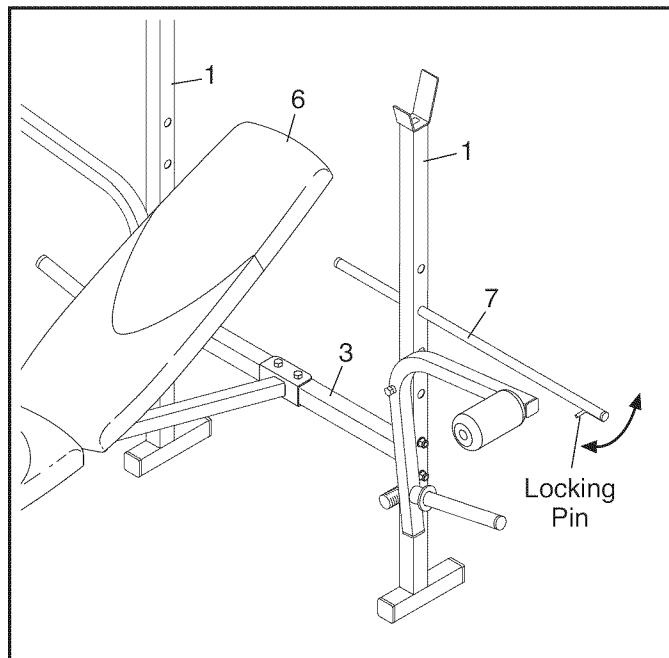

ATTACHING WEIGHTS TO THE LEG LEVER OR THE FLY ARMS

To use the Leg Lever (4), slide the desired weights onto the weight tube on the Leg Lever.

To use the Fly Arms (25), make sure there is a Weight Stop (28) on each weight tube. Then, slide the desired weights onto the weight tubes.

⚠ WARNING: When using the Leg Lever (4), place a barbell with the same amount of weight on the weight rests to balance the bench. Do not place more than 50 lbs. (23 kg) on the Leg Lever. Do not place more than 30 lbs. (14 kg) on each Fly Arm (25).

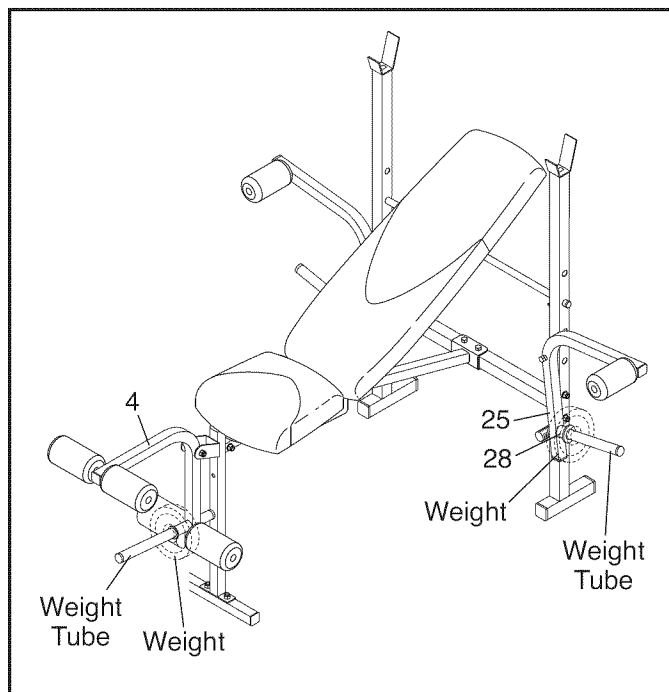

ATTACHING WEIGHTS TO THE BARBELL

Slide the same amount of Weight (38, 41) onto both ends of the Barbell (40). Slide the two Spring Collars (42) against the Weights, and tighten them fully.

⚠ WARNING: Always secure Weights (38, 41) on the Barbell (40) with the Spring Collars (42). Never use the Barbell with more than 100 lbs. (45 kg).

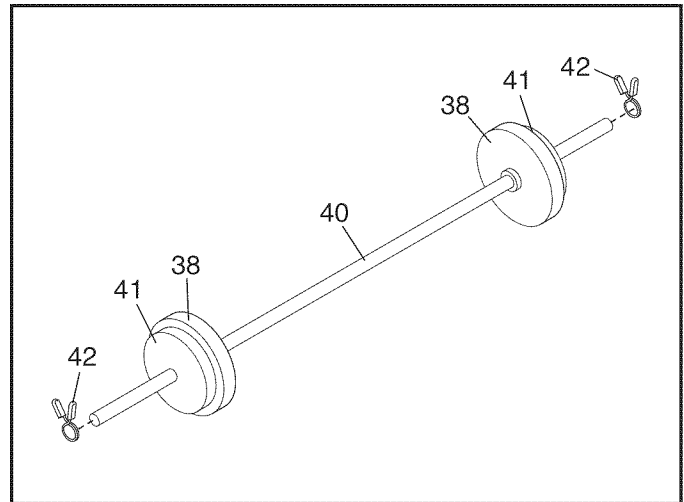

ATTACHING THE CURL PAD

For some exercises, the Curl Pad (43) must be attached to the weight bench. First, remove the 30mm Square Inner Cap (22) from the Front Leg (8). Next, insert the Curl Post (27) into the Front Leg, and align an adjustment hole in the Curl Post with the adjustment hole in the Front Leg. Then, secure the Curl Post with the Curl Knob (31).

When the Curl Pad (43) is not being used, store it away from the weight bench, and insert the 30mm Square Inner Cap (22) into the Front Leg (8).

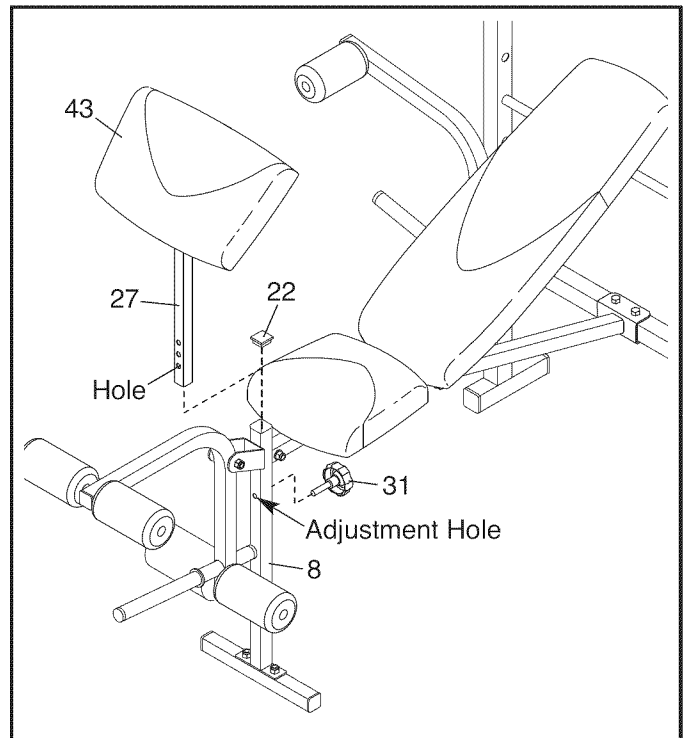

EXERCISE GUIDELINES

FOUR TYPES OF STRENGTH WORKOUTS

Note: A “repetition” is one complete cycle of an exercise, such as one sit-up. A “set” is a series of repetitions.

Muscle Building—Work your muscles near their maximum capacity and progressively increase the intensity of your exercise. Adjust the intensity level of an individual exercise as follows:

- Change the amount of resistance used.
- Change the number of repetitions or sets performed.

Use your own judgment to determine the amount of resistance that is right for you. Begin with 3 sets of 8 repetitions for each exercise you perform. Rest for 3 minutes after each set. When you can complete 3 sets of 12 repetitions without difficulty, increase the amount of resistance.

Toning—Tone your muscles by working them to a moderate percentage of their capacity. Select a moderate amount of resistance and increase the number of repetitions in each set. Complete as many sets of 15 to 20 repetitions as possible without discomfort. Rest for 1 minute after each set. Work your muscles by completing more sets rather than by using high amounts of resistance.

Weight Loss—To lose weight, use a low amount of resistance and increase the number of repetitions in each set. Exercise for 20 to 30 minutes, resting for a maximum of 30 seconds between sets.

Cross Training—Combine strength training and aerobic exercise by following this type of program:

- Strength training workouts on Monday, Wednesday, and Friday.
- 20 to 30 minutes of aerobic exercise on Tuesday and Thursday.
- One full day of rest each week to give your body time to regenerate.

WORKOUT GUIDELINES

Familiarize yourself with the equipment and learn the proper form for each exercise. Use your own judgment to determine the appropriate length of time for each

workout, and the numbers of repetitions and sets to complete. Progress at your own pace and be sensitive to your body’s signals. Follow each workout with at least one day of rest.

Warming Up—Start with 5 to 10 minutes of stretching and light exercise. A warm-up increases your body temperature, heart rate, and circulation in preparation for exercise.

Working Out—Include 6 to 10 different exercises in each workout. Select exercises for every major muscle group, emphasizing areas that you want to develop. To give balance and variety to your workouts, vary the exercises from workout to workout.

Cooling Down—Finish with 5 to 10 minutes of stretching. Stretching increases the flexibility of your muscles and helps to prevent post-exercise problems.

EXERCISE FORM

Move through the full range of motion for each exercise and move only the appropriate parts of the body. Perform the repetitions in each set smoothly and without pausing. The exertion stage of each repetition should last about half as long as the return stage. Exhale during the exertion stage of each repetition and inhale during the return stroke. Never hold your breath.

Rest for a short period of time after each set:

- Muscle Building—Rest for three minutes after each set.
- Toning—Rest for one minute after each set.
- Weight Loss—Rest for 30 seconds after each set.

STAYING MOTIVATED

For motivation, keep a record of each workout. Write the date, the exercises performed, the resistance used, and the numbers of sets and repetitions completed. Record your weight and key body measurements once a month. To achieve good results, make exercise a regular and enjoyable part of your life.

EXERCISE LOG

Make copies of this page, and use the copies to schedule and record your strength and aerobic workouts. Scheduling and recording your workouts will help you to make exercise a regular and enjoyable part of your life.

Strength

Date:

____ / ____ / ____

Exercise	Lbs.	Sets	Reps	Exercise	Lbs.	Sets	Reps
1.				6.			
2.				7.			
3.				8.			
4.				9.			
5.				10.			

Aerobic

Date:

____ / ____ / ____

Exercise	Time	Distance	Speed

Strength

Date:

____ / ____ / ____

Exercise	Lbs.	Sets	Reps	Exercise	Lbs.	Sets	Reps
1.				6.			
2.				7.			
3.				8.			
4.				9.			
5.				10.			

Aerobic

Date:

____ / ____ / ____

Exercise	Time	Distance	Speed

Strength

Date:

____ / ____ / ____

Exercise	Lbs.	Sets	Reps	Exercise	Lbs.	Sets	Reps
1.				6.			
2.				7.			
3.				8.			
4.				9.			
5.				10.			

Aerobic

Date:

____ / ____ / ____

Exercise	Time	Distance	Speed

PART LIST

Sears Model No. 831.15999.3; Kmart Model No. WEBE0939.3 R0811A

Key No.	Qty.	Description	Key No.	Qty.	Description
1	2	Upright	24	5	25mm Round Inner Cap
2	1	Frame	25	2	Fly Arm
3	1	Crossbar	26	4	M6 Washer
4	1	Leg Lever	27	1	Curl Post
5	2	Backrest Tube	28	2	Weight Stop
6	1	Backrest	29	6	M6 x 16mm Screw
7	1	Backrest Support	30	4	M6 x 38mm Screw
8	1	Front Leg	31	1	Curl Knob
9	8	19mm Round Inner Cap	32	1	M10 x 63mm Bolt
10	2	Long Pad Tube	33	4	M10 Locknut
11	1	Seat	34	2	M10 Washer
12	2	Short Pad Tube	35	4	25mm Square Inner Cap
13	1	Stabilizer	36	1	M10 x 137mm Bolt
14	4	Plastic Bushing	37	2	M8 x 42mm Carriage Bolt
15	2	Fly Arm Stop	38	4	15-lb. Weight
16	8	M8 Washer	39	2	M8 x 43mm Bolt
17	10	M8 Locknut	40	1	Barbell
18	6	M8 x 55mm Bolt	41	2	10-lb. Weight
19	2	M10 x 120mm Bolt	42	2	Spring Collar
20	1	25mm Round Angled Cap	43	1	Curl Pad
21	4	38mm Square Inner Cap	*	–	User's Manual
22	9	30mm Square Inner Cap	*	–	Exercise Guide
23	6	Foam Pad	*	–	Grease Packet

Note: Specifications are subject to change without notice. For information about ordering replacement parts, see the back cover of this manual. *These parts are not illustrated.

EXPLODED DRAWING

Sears Model No. 831.15999.3; Kmart Model No. WEBE0939.3

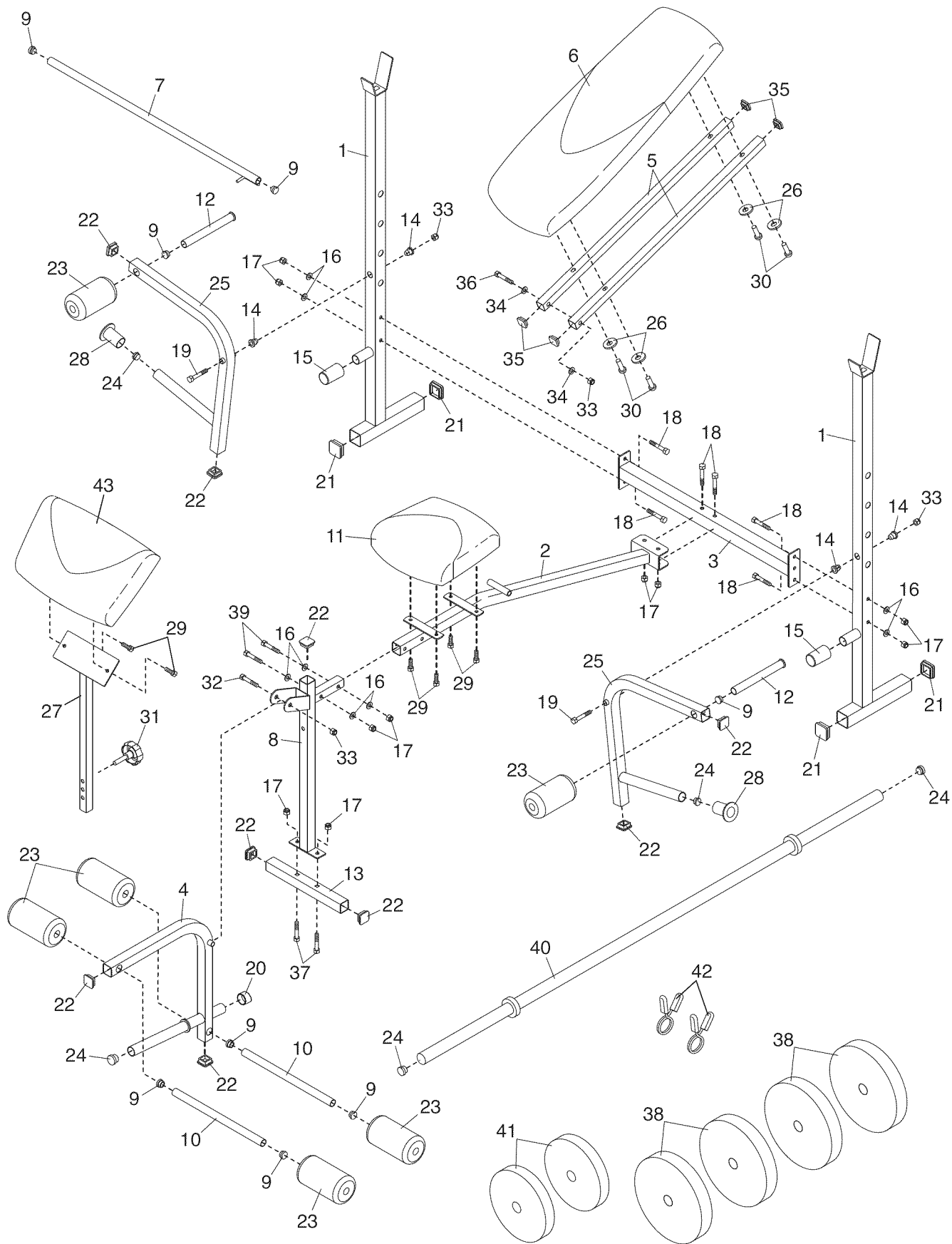

R0811A

ORDERING REPLACEMENT PARTS

To order replacement parts, please see the front cover of this manual. To help us assist you, be prepared to provide the following information when contacting us:

- the model number and serial number of the product (see the front cover of this manual)
- the name of the product (see the front cover of this manual)
- the key number and description of the replacement part(s) (see the PART LIST and the EXPLODED DRAWING near the end of this manual)

LIMITED WARRANTY

IMPORTANT: You must register this product within 30 days of the purchase date to avoid added fees for service needed under warranty. Go to www.weiderservice.com/registration.

ICON Health & Fitness, Inc. (ICON) warrants this product to be free from defects in workmanship and material, under normal use and service conditions. Parts and labor are warranted for ninety (90) days from the date of purchase.

This warranty extends only to the original purchaser (customer). ICON's obligation under this warranty is limited to repairing or replacing, at ICON's option, the product through one of its authorized service centers. All repairs for which warranty claims are made must be preauthorized by ICON. If the product is shipped to a service center, freight charges to and from the service center will be the customer's responsibility. If replacement parts are shipped while the product is under warranty, the customer will be responsible for a minimal handling charge. For in-home service, the customer will be responsible for a minimal trip charge. This warranty does not extend to freight damage to the product. This warranty will automatically be voided if the product is used as a store display model, if the product is purchased or transported outside the USA, if all instructions in this manual are not followed, if the product is abused or improperly or abnormally used, or if the product is used for commercial or rental purposes. No other warranty beyond that specifically set forth above is authorized by ICON.

ICON is not responsible or liable for indirect, special, or consequential damages arising out of or in connection with the use or performance of the product; damages with respect to any economic loss, loss of property, loss of revenues or profits, loss of enjoyment or use, or costs of removal or installation; or other consequential damages of any kind. Some states do not allow the exclusion or limitation of incidental or consequential damages. Accordingly, the above limitation may not apply to the customer.

The warranty extended hereunder is in lieu of any and all other warranties, and any implied warranties of merchantability or fitness for a particular purpose are limited in their scope and duration to the terms set forth herein. Some states do not allow limitations on how long an implied warranty lasts. Accordingly, the above limitation may not apply to the customer.

This warranty provides specific legal rights; the customer may have other rights that vary from state to state.

ICON Health & Fitness, Inc., 1500 S. 1000 W., Logan, UT 84321-9813