

INSTALLATION INSTRUCTIONS

30" (76.2 CM) FREESTANDING GAS RANGES

Table of Contents

RANGE SAFETY	2
INSTALLATION REQUIREMENTS.....	4
Tools and Parts.....	4
Location Requirements.....	4
Electrical Requirements.....	6
Gas Supply Requirements.....	6
INSTALLATION INSTRUCTIONS.....	8
Unpack Range	8
Install Anti-Tip Bracket	8
Make Gas Connection.....	9
Verify Anti-Tip Bracket Location.....	10
Level Range	11
Electronic Ignition System.....	11
Replace Oven Racks and Warming Drawer.....	12
Storage Drawer.....	13
Complete Installation	13
GAS CONVERSIONS	14
LP Gas Conversion.....	14
Natural Gas Conversion.....	16
ANTI-TIP BRACKET TEMPLATE	19

IMPORTANT:

Save for local inspector's use.

Installer: Leave installation instructions with the homeowner.

Homeowner: Keep installation instructions for future reference.

RANGE SAFETY

Your safety and the safety of others are very important.

We have provided many important safety messages in this manual and on your appliance. Always read and obey all safety messages.



This is the safety alert symbol.

This symbol alerts you to potential hazards that can kill or hurt you and others.

All safety messages will follow the safety alert symbol and either the word "DANGER" or "WARNING."

These words mean:

⚠ DANGER

You can be killed or seriously injured if you don't immediately follow instructions.

⚠ WARNING

You can be killed or seriously injured if you don't follow instructions.

All safety messages will tell you what the potential hazard is, tell you how to reduce the chance of injury, and tell you what can happen if the instructions are not followed.

WARNING: If the information in this manual is not followed exactly, a fire or explosion may result causing property damage, personal injury or death.

- Do not store or use gasoline or other flammable vapors and liquids in the vicinity of this or any other appliance.
- **WHAT TO DO IF YOU SMELL GAS:**
 - Do not try to light any appliance.
 - Do not touch any electrical switch.
 - Do not use any phone in your building.
 - Immediately call your gas supplier from a neighbor's phone. Follow the gas supplier's instructions.
 - If you cannot reach your gas supplier, call the fire department.
- Installation and service must be performed by a qualified installer, service agency or the gas supplier.

WARNING: Gas leaks cannot always be detected by smell.

Gas suppliers recommend that you use a gas detector approved by UL or CSA.

For more information, contact your gas supplier.

If a gas leak is detected, follow the "What to do if you smell gas" instructions.

In the State of Massachusetts, the following installation instructions apply:

- Installations and repairs must be performed by a qualified or licensed contractor, plumber, or gasfitter qualified or licensed by the State of Massachusetts.
- If using a ball valve, it shall be a T-handle type.
- A flexible gas connector, when used, must not exceed 3 feet.



⚠ WARNING

Tip Over Hazard

A child or adult can tip the range and be killed.

Connect anti-tip bracket to rear range foot.

Reconnect the anti-tip bracket, if the range is moved.

Failure to follow these instructions can result in death or serious burns to children and adults.

INSTALLATION REQUIREMENTS

Tools and Parts

Gather the required tools and parts before starting installation. Read and follow the instructions provided with any tools listed here.

Tools needed

- Tape measure
- Flat-blade screwdriver
- Phillips screwdriver
- Level
- Hand or electric drill
- Hammer
- Wrench or pliers
- Pipe wrench
- $\frac{15}{16}$ " combination wrench
- $\frac{1}{4}$ " drive ratchet
- $\frac{3}{8}$ " nut driver
- $\frac{1}{8}$ " (3.2 mm) drill bit (for wood floors)
- Marker or pencil
- Pipe-joint compound resistant to LP gas
- $\frac{3}{16}$ " (4.8 mm) carbide-tipped masonry drill bit (for concrete/ceramic floors)
- Noncorrosive leak-detection solution

For LP/Natural Gas Conversions

- $\frac{1}{2}$ " combination wrench
- $\frac{5}{8}$ " combination wrench
- 7 mm ($\frac{9}{32}$ ") nut driver
- Quadrex®† or Phillips screwdriver
- Masking tape

Parts supplied

Check that all parts are included.

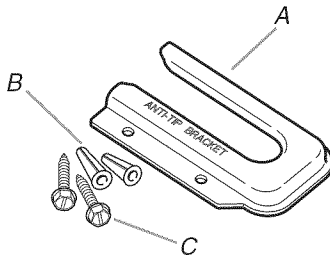

A. Anti-tip bracket
B. Plastic anchors (2)
C. #10 x $\frac{1}{2}$ " screws (2)

- Anti-tip bracket must be securely mounted to subfloor. Thickness of flooring may require longer screws to anchor bracket to subfloor. Longer screws are available from your local hardware store.

Parts needed

Check local codes and consult gas supplier. Check existing gas supply and electrical supply. See "Electrical Requirements" and "Gas Supply Requirements" sections.

Location Requirements

IMPORTANT: Observe all governing codes and ordinances. Do not obstruct flow of combustion and ventilation air.

- It is the installer's responsibility to comply with installation clearances specified on the model/serial rating plate. The model/serial rating plate is located on the oven frame behind the top left side of the oven door.
- The range should be located for convenient use in the kitchen.
- Recessed installations must provide complete enclosure of the sides and rear of the range.
- All openings in the wall or floor where range is to be installed must be sealed.
- Do not seal the range to the side cabinets.
- Cabinet opening dimensions that are shown must be used. Given dimensions are minimum clearances.
- The floor anti-tip bracket must be installed. To install the anti-tip bracket shipped with the range, see "Install Anti-Tip Bracket" section.
- Grounded electrical supply is required. See "Electrical Requirements" section.
- Proper gas supply connection must be available. See "Gas Supply Requirements" section.
- Contact a qualified floor covering installer to check that the floor covering can withstand at least 200°F (93°C).
- Use an insulated pad or $\frac{1}{4}$ " (0.64 cm) plywood under range if installing range over carpeting.

IMPORTANT: To avoid damage to your cabinets, check with your builder or cabinet supplier to make sure that the materials used will not discolor, delaminate or sustain other damage. This oven has been designed in accordance with the requirements of UL and CSA International and complies with the maximum allowable wood cabinet temperatures of 194°F (90°C).

Mobile Home - Additional Installation Requirements

The installation of this range must conform to the Manufactured Home Construction and Safety Standard, Title 24 CFR, Part 3280 (formerly the Federal Standard for Mobile Home Construction and Safety, Title 24, HUD Part 280). When such standard is not applicable, use the Standard for Manufactured Home Installations, ANSI A225.1/NFPA 501A or with local codes.

In Canada, the installation of this range must conform with the current standards CAN/CSA-A240-latest edition, or with local codes.

Mobile home installations require:

- When this range is installed in a mobile home, it must be secured to the floor during transit. Any method of securing the range is adequate as long as it conforms to the standards listed above.

Product Dimensions

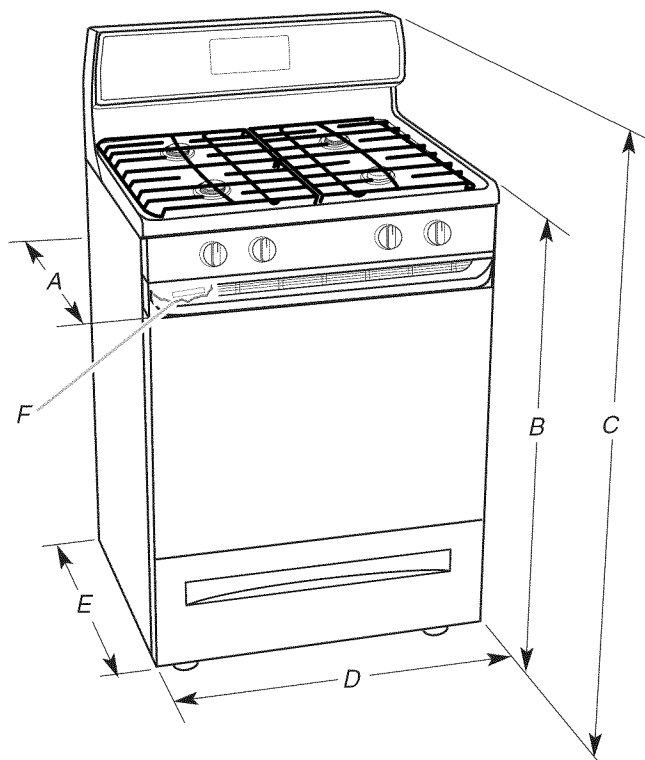

- A. 27¹⁷/₃₂" (69.9 cm) max. depth with handle
- B. 36" (91.4 cm) cooktop height (max.) with leveling legs screwed all the way in*
- C. 46⁷/₈" (119.1 cm) overall height (max.) with leveling legs screwed all the way in*
- D. 29⁷/₈" (75.9 cm) width
- E. 25" (63.5 cm)
- F. Model/serial rating plate (located on the oven frame behind the top left side of the oven door)

*Range can be raised approximately 1" (2.5 cm) by adjusting the leveling legs.

Cabinet Dimensions

Cabinet opening dimensions shown are for 25" (64.0 cm) countertop depth, 24" (61.0 cm) base cabinet depth and 36" (91.4 cm) countertop height.

IMPORTANT: If installing a range hood or microwave hood combination above the range, follow the range hood or microwave hood combination installation instructions for dimensional clearances above the cooktop surface.

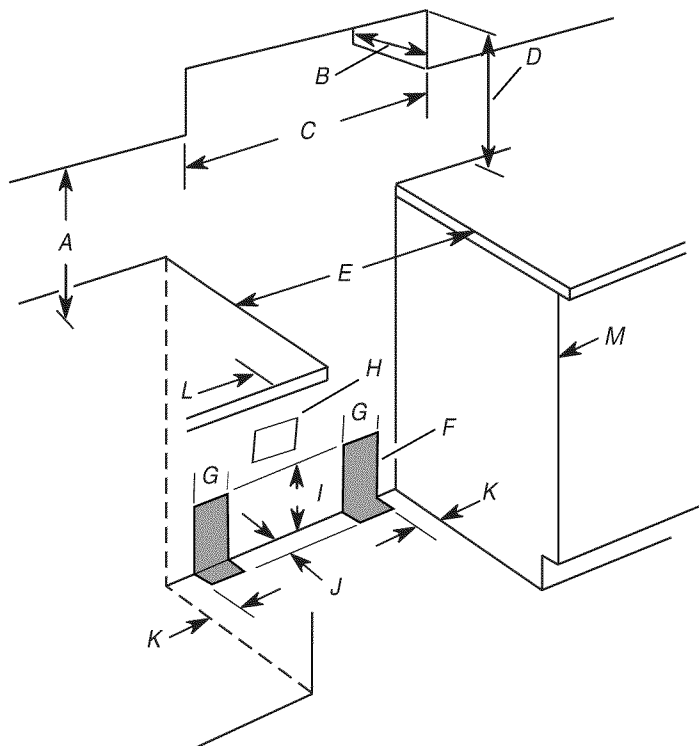

- A. 18" (45.7 cm) upper side cabinet to countertop
- B. 13" (33 cm) max. upper cabinet depth
- C. 30" (76.2 cm) min. opening width
- D. For minimum clearance to top of cooktop, see NOTE*.
- E. 30¹/₈" (76.5 cm) min. opening width
- F. This shaded area recommended for installation of rigid gas pipe.
- G. 8" (20.3 cm)
- H. Grounded outlet
- I. 1.7" (43.2 cm)
- J. 2" (5.1 cm)
- K. 4¹/₂" (11.4 cm)
- L. 2" (5.1 cm) min. clearance from both sides of range to side wall or other combustible material.

*NOTE: 24" (61.0 cm) minimum when bottom of wood or metal cabinet is covered by not less than 1/4" (0.64 cm) flame retardant millboard covered with not less than No. 28 MSG sheet steel, 0.015" (0.4 mm) stainless steel, 0.024" (0.6 mm) aluminum or 0.020" (0.5 mm) copper.

30" (76.2 cm) minimum clearance between the top of the cooking platform and the bottom of an uncovered wood or metal cabinet.

Electrical Requirements

⚠ WARNING



Electrical Shock Hazard

Plug into a grounded 3 prong outlet.

Do not remove ground prong.

Do not use an adapter.

Do not use an extension cord.

Failure to follow these instructions can result in death, fire, or electrical shock.

IMPORTANT: The range must be electrically grounded in accordance with local codes and ordinances, or in the absence of local codes, with the National Electrical Code, ANSI/NFPA 70 or Canadian Electrical Code, CSA C22.1.

This range is equipped with an electronic ignition system that will not operate if plugged into an outlet that is not properly polarized. If codes permit and a separate ground wire is used, it is recommended that a qualified electrical installer determine that the ground path is adequate.

A copy of the above code standards can be obtained from:

National Fire Protection Association
One Batterymarch Park
Quincy, MA 02269
CSA International
8501 East Pleasant Valley Road
Cleveland, OH 44131-5575

- A 120 volt, 60 Hz., AC only, 15-amp fused, electrical circuit is required. A time-delay fuse or circuit breaker is also recommended. It is recommended that a separate circuit serving only this range be provided.
- Electronic ignition systems operate within wide voltage limits, but proper grounding and polarity are necessary. Check that the outlet provides 120-volt power and is correctly grounded.
- This gas range is not required to be plugged into a GFCI (Ground-Fault Circuit Interrupter) outlet. It is recommended that you not plug an electric spark ignition gas range or any other major appliance into a GFCI wall outlet as it will cause the GFCI to trip during normal cycling.
- Performance of this range will not be affected if operated on a GFCI-protected circuit. However, occasional nuisance tripping of the GFCI breaker is possible due to the normal operating nature of electronic gas ranges.
- The wiring diagram is located on the back of the range in a clear plastic bag.

NOTE: The metal chassis of the range must be grounded in order for the control panel to work. If the metal chassis of the range is not grounded, no keypads will operate. Check with a qualified electrician if you are in doubt as to whether the metal chassis of the range is grounded.

Gas Supply Requirements

⚠ WARNING



Explosion Hazard

Use a new CSA International approved gas supply line.

Install a shut-off valve.

Securely tighten all gas connections.

If connected to LP, have a qualified person make sure gas pressure does not exceed 14" (36 cm) water column.

Examples of a qualified person include:

licensed heating personnel,
authorized gas company personnel, and
authorized service personnel.

Failure to do so can result in death, explosion, or fire.

Observe all governing codes and ordinances.

IMPORTANT: This installation must conform with all local codes and ordinances. In the absence of local codes, installation must conform with American National Standard, National Fuel Gas Code ANSI Z223.1 - latest edition or CAN/CGA B149 - latest edition.

IMPORTANT: Leak testing of the range must be conducted according to the manufacturer's instructions.

Type of Gas

Natural gas:

This range is design-certified by CSA International for use with Natural gas or, after proper conversion, for use with LP gas.

- This range is factory set for use with Natural gas. See "Gas Conversions" section. The model/serial rating plate located on the oven frame behind the top left side of the oven door has information on the types of gas that can be used. If the types of gas listed do not include the type of gas available, check with the local gas supplier.

LP gas conversion:

Conversion must be done by a qualified service technician.

No attempt shall be made to convert the appliance from the gas specified on the model/serial rating plate for use with a different gas without consulting the serving gas supplier. See "Gas Conversions" section.

Gas Supply Line

- Provide a gas supply line of 3/4" (1.9 cm) rigid pipe to the range location. A smaller size pipe on longer runs may result in insufficient gas supply. With LP gas, piping or tubing size can be 1/2" (1.3 cm) minimum. Usually, LP gas suppliers determine the size and materials used in the system.

NOTE: Pipe-joint compounds that resist the action of LP gas must be used. Do not use TEFLON^{®†} tape.

†TEFLON is a registered trademark of E.I. Du Pont De Nemours and Company.

Flexible metal appliance connector:

- If local codes permit, a new CSA design-certified, 4 to 5 ft (122 to 152.4 cm) long, 1/2" (1.3 cm) or 3/4" (1.9 cm) I.D., flexible metal appliance connector may be used for connecting range to the gas supply line.

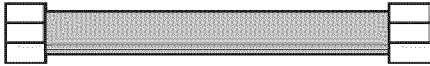

- A 1/2" (1.3 cm) male pipe thread is needed for connection to the female pipe threads of the inlet to the appliance pressure regulator.
- Do not kink or damage the flexible metal tubing when moving the range.

Rigid pipe connection:

The rigid pipe connection requires a combination of pipe fittings to obtain an in-line connection to the range. The rigid pipe must be level with the range connection. All strains must be removed from the supply and fuel lines so range will be level and in line.

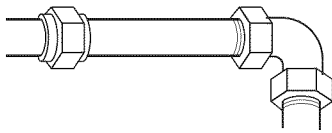

- Must include a shutoff valve:
The supply line must be equipped with a manual shutoff valve. This valve should be located in the same room but external to the range opening, such as an adjacent cabinet. It should be in a location that allows ease of opening and closing. Do not block access to shutoff valve. The valve is for turning on or shutting off gas to the range.

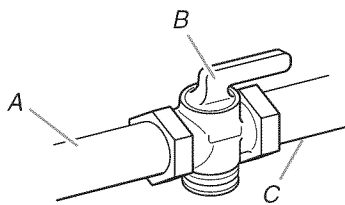

A. Gas supply line
B. Shutoff valve "open" position
C. To range

Gas Pressure Regulator

The gas pressure regulator supplied with this range must be used. The inlet pressure to the regulator should be as follows for proper operation:

Natural gas:

Minimum pressure: 5" WCP

Maximum pressure: 14" WCP

LP gas:

Minimum pressure: 11" WCP

Maximum pressure: 14" WCP

Contact local gas supplier if you are not sure about the inlet pressure.

Burner Input Requirements

Input ratings shown on the model/serial rating plate are for elevations up to 2,000 ft (609.6 m).

For elevations above 2,000 ft (609.6 m), ratings are reduced at a rate of 4% for each 1,000 ft (304.8 m) above sea level (not applicable for Canada).

Gas Supply Pressure Testing

Gas supply pressure for testing regulator must be at least 1" water column pressure above the manifold pressure shown on the model/serial rating plate.

Line pressure testing above 1/2 psi gauge (14" WCP)

The range and its individual shutoff valve must be disconnected from the gas supply piping system during any pressure testing of that system at test pressures in excess of 1/2 psi (3.5 kPa).

Line pressure testing at 1/2 psi gauge (14" WCP) or lower

The range must be isolated from the gas supply piping system by closing its individual manual shutoff valve during any pressure testing of the gas supply piping system at test pressures equal to or less than 1/2 psi (3.5 kPa).

INSTALLATION INSTRUCTIONS

Unpack Range

⚠️ WARNING

Excessive Weight Hazard

Use two or more people to move and install range.
Failure to do so can result in back or other injury.

1. Remove shipping materials, tape and film from range.
2. Remove oven racks and parts package from inside oven.
3. Do not remove the shipping base at this time.

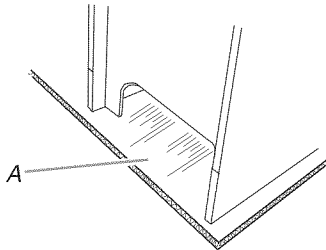

A. Shipping base

4. On Ranges Equipped with Storage Drawers:

Remove the storage drawer. See the "Storage Drawer" section. Use a 1/4" drive ratchet to lower the rear leveling legs one-half turn. Use a wrench or pliers to lower front leveling legs one-half turn.

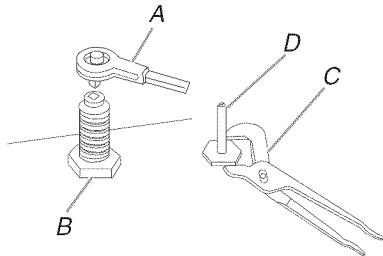

A. 1/4" drive ratchet
B. Rear leveling leg
C. Wrench or pliers
D. Front leveling leg

On Ranges Equipped with Warming Drawers:

On ranges equipped with a warming drawer, the rear legs cannot be accessed by removing the warming drawer. It will be necessary to adjust the rear legs from outside the range. Use wrench or pliers to lower the front and rear leveling legs one-half turn.

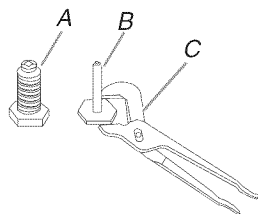

A. Rear leveling leg
B. Front leveling leg
C. Wrench or pliers

Install Anti-Tip Bracket

⚠️ WARNING

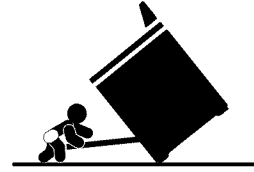

Tip Over Hazard

A child or adult can tip the range and be killed.

Connect anti-tip bracket to rear range foot.

Reconnect the anti-tip bracket, if the range is moved.

Failure to follow these instructions can result in death or serious burns to children and adults.

Contact a qualified floor covering installer for the best procedure for drilling mounting holes through your type of floor covering.

Before moving range, slide range onto shipping base, cardboard or hardboard.

1. Remove template from the anti-tip bracket kit (found inside the oven cavity) or from the back of this manual.
2. Place template on the floor in cabinet opening so that the left edge is against cabinet and top edge is against rear wall, molding or cabinet.
3. Tape template into place.
4. If countertop is not flush with cabinet opening edge, align template with overhang.

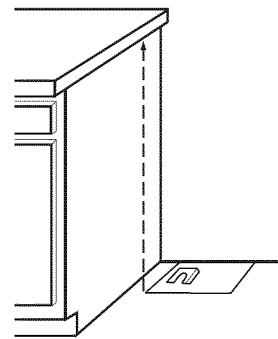

If cabinet opening is wider than that specified in the "Location Requirements" section, adjust template so range will be centered in cabinet opening.

- To mount anti-tip bracket to wood floor, drill two 1/8" (3.2 mm) holes at the positions marked on the bracket template. Remove template from floor.

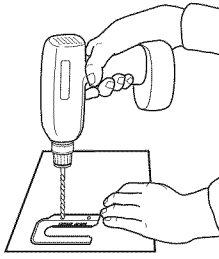

To mount anti-tip bracket to concrete or ceramic floor, use a 3/16" (4.8 mm) masonry drill bit to drill 2 holes at the positions marked on the bracket template. Remove template from floor. Tap plastic anchors into holes with a hammer.

- Align anti-tip bracket holes with holes in floor. Fasten anti-tip bracket with screws provided.

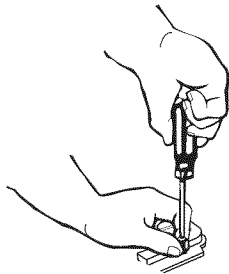

Depending on the thickness of your flooring, longer screws may be necessary to anchor the bracket to the subfloor. Longer screws are available from your local hardware store.

- Move range close enough to opening to allow for final electrical connection. Remove shipping base, cardboard or hardboard from under range.
- Move range into its final location making sure rear leveling leg slides into anti-tip bracket.

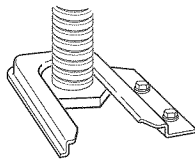

- If installing the range in a mobile home, you must secure the range to the floor. Any method of securing the range is adequate as long as it conforms to the standards in the "Location Requirements" section.
- Continue installing your range using the following installation instructions.

Make Gas Connection

⚠ WARNING



Explosion Hazard

Use a new CSA International approved gas supply line.

Install a shut-off valve.

Securely tighten all gas connections.

If connected to LP, have a qualified person make sure gas pressure does not exceed 14" (36 cm) water column.

Examples of a qualified person include:

**licensed heating personnel,
authorized gas company personnel, and
authorized service personnel.**

Failure to do so can result in death, explosion, or fire.

Typical rigid pipe connection

A combination of pipe fittings must be used to connect the range to the existing gas line. Your connections may be different, according to the supply line type, size and location.

- Apply pipe-joint compound made for use with LP gas to all pipe thread connections.
- Using a pipe wrench to tighten, connect the gas supply to the range.

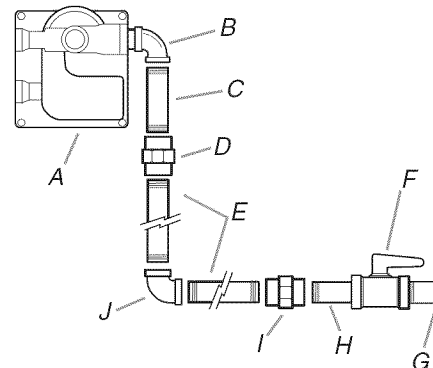

A. Gas pressure regulator

B. 90° elbow (must have 1/2" male pipe thread)

C. Nipple

D. Union

E. Black iron pipe

F. Manual gas shutoff valve

G. 1/2" or 3/4" gas pipe

H. Nipple

I. Union

J. 90° elbow

Typical flexible connection

- Apply pipe-joint compound made for use with LP gas to the smaller thread ends of the flexible connector adapters (see B and G in the following illustration).
- Attach one adapter to the gas pressure regulator and the other adapter to the gas shutoff valve. Tighten both adapters.

- Use a $\frac{15}{16}$ " combination wrench and channel lock pliers to attach the flexible connector to the adapters. Check that connector is not kinked.

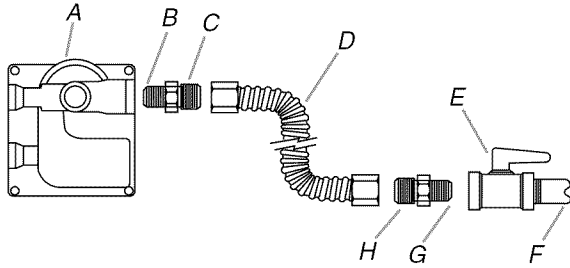

- | | |
|---|--|
| A. Gas pressure regulator | E. Manual gas shutoff valve |
| B. Use pipe-joint compound. | F. $\frac{1}{2}$ " or $\frac{3}{4}$ " gas pipe |
| C. Adapter (must have $\frac{1}{2}$ " male pipe thread) | G. Use pipe-joint compound. |
| D. Flexible connector | H. Adapter |

Complete Connection

- Check that the gas pressure regulator shutoff valve is in the "on" position.

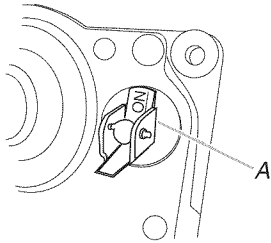

A. Gas pressure regulator shutoff valve

- Open the manual shutoff valve in the gas supply line. The valve is open when the handle is parallel to the gas pipe.

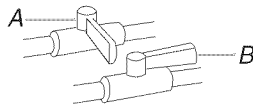

A. Closed valve
B. Open valve

- Test all connections by brushing on an approved noncorrosive leak-detection solution. If bubbles appear, a leak is indicated. Correct any leak found.
- Remove cooktop burner caps and grates from parts package. Burner caps should be level when properly positioned. If burner caps are not properly positioned, surface burners will not light. Place burner grates over burners and caps.

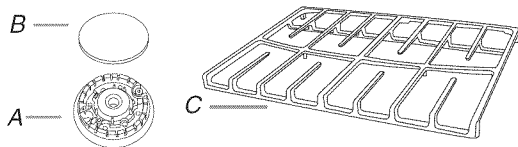

A. Burner base
B. Burner cap
C. Burner grate

WARNING



Electrical Shock Hazard

- Plug into a grounded 3 prong outlet.
- Do not remove ground prong.
- Do not use an adapter.
- Do not use an extension cord.
- Failure to follow these instructions can result in death, fire, or electrical shock.

- Plug into a grounded 3 prong outlet.

Verify Anti-Tip Bracket Location

- On models with a storage drawer, remove the storage drawer. See "Storage Drawer" section.
On models with a warming drawer, the rear leg cannot be seen by removing the warming drawer. It will be necessary to view the rear foot from outside the range.

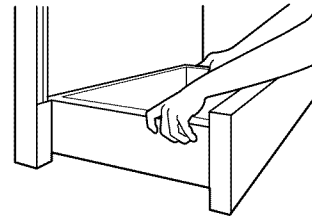

- To check that the anti-tip bracket is installed, use a flashlight and look underneath the bottom of the range.
 - Look for the anti-tip bracket securely attached to floor.
 - Slide range back so rear range foot is under anti-tip bracket.

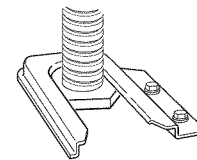

Level Range

1. Place a rack in oven.
2. Place level on rack and check levelness of range, first side to side; then front to back.

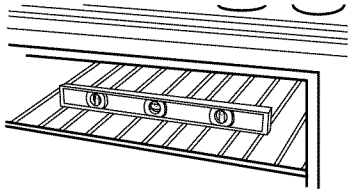

3. If range is not level, pull range forward until rear leveling leg is removed from the anti-tip bracket.

On Ranges Equipped with Storage Drawers:

Use a ¼" drive ratchet, wrench or pliers to adjust leveling legs up or down until the range is level. Push range back into position. Check that rear leveling leg is engaged in the anti-tip bracket.

On Ranges Equipped with Warming Drawers:

Use a wrench or pliers to adjust leveling legs up or down until the range is level. Push range back into position. Check that rear leveling leg is engaged in the anti-tip bracket.

NOTE: Range must be level for satisfactory baking performance.

Electronic Ignition System

Initial lighting and gas flame adjustments

Cooktop and oven burners use electronic igniters in place of standing pilots. When the cooktop control knob is turned to the "LITE" position, the system creates a spark to light the burner. This sparking continues, as long as the control knob is turned to "LITE."

When the oven control is turned to the desired setting, sparking occurs and ignites the gas.

Check Operation of Cooktop Burners

Standard Surface Burners

Push in and turn each control knob to the "LITE" position.

The flame should light within 4 seconds. The first time a burner is lit, it may take longer than 4 seconds to light because of air in the gas line.

If burners do not light properly:

- Turn cooktop control knob to the "OFF" position.
- Check that the range is plugged in. Check that the circuit breaker has not tripped or the household fuse has not blown.
- Check that the gas shutoff valves are set to the "open" position.
- Check that burner caps are properly positioned on burner bases.

Repeat start-up. If a burner does not light at this point, turn the control knobs to "Off" and contact your dealer or authorized service company for assistance.

Adjust Flame Height

Adjust the height of top burner flames. The cooktop "low" burner flame should be a steady blue flame approximately ¼" (0.64 cm) high.

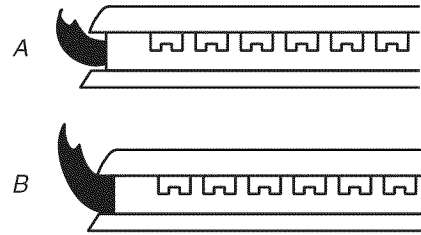

A. Low flame
B. High flame

To adjust standard burner:

The flame can be adjusted using the adjustment screw in the center of the valve stem. The valve stem is located directly underneath the control knob.

If the "low" flame needs to be adjusted:

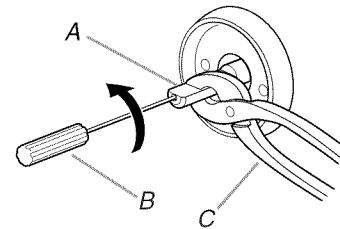

A. Control knob stem
B. Screwdriver
C. Pliers

1. Light 1 burner and turn to lowest setting.
2. Remove the control knob.
Hold the knob stem with a pair of pliers. Use a small flat-blade screwdriver to turn the screw located in the center of the control knob stem until the flame is the proper size.
3. Replace the control knob.
4. Test the flame by turning the control from "LO" to "HI," checking the flame at each setting.
5. Repeat above steps for each burner.

Check Operation of Oven Bake Burner

1. Remove the oven rack.
2. To remove the oven bottom: Remove 2 screws at the rear of the oven bottom. Lift the rear of the oven bottom up and back until the front of the panel is away from the front frame. Remove from oven and place on a covered surface.

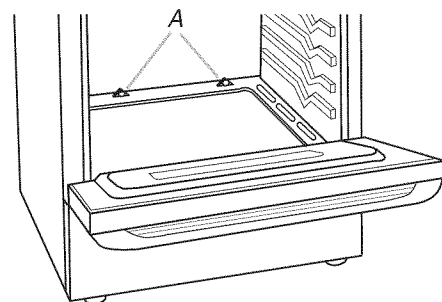

A. Screws

- You can check the burner flame by removing the flame spreader or by using a mirror.

Remove flame spreader:

Remove 2 screws from the front tabs of the flame spreader. Lift front of the flame spreader and pull forward to remove tabs from rear of oven.

Using a mirror:

Insert a mirror to one side of the burner. Look into the mirror to check flame.

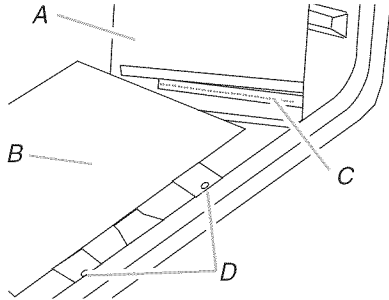

A. Mirror
B. Flame spreader
C. Flame reflection
D. 2 screws

- Press the BAKE pad.
- Press the START pad.

The oven bake burner should light within 8 seconds. Under certain conditions, it may take the burner up to 50 to 60 seconds to light.

Electronic igniters are used to light the bake and broil burners.

Refer to the Use and Care Guide for proper operation of the oven controls.

Adjust Oven Bake Burner Flame (if needed)

- On models with a warming drawer, remove access cover plate (1 screw) located at the back of the warming drawer compartment.
- Check the oven bake burner for proper flame. This flame should have a 1/2" (1.3 cm) long inner cone of bluish-green, with an outer mantle of dark blue, and should be clean and soft in character. No yellow tips, blowing or lifting of flame should occur.
- If the oven bake flame needs to be adjusted, locate the air shutter near the center rear of the range. Loosen the locking screw and rotate the air shutter until the proper flame appears. Tighten locking screw.

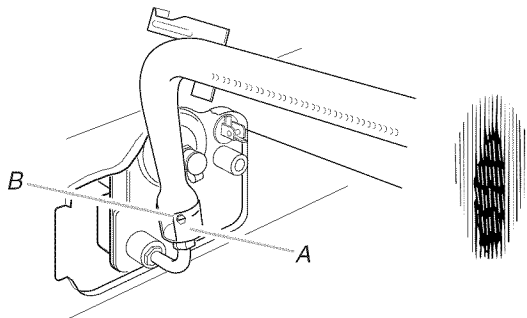

A. Air shutter
B. Locking screw

- Press CANCEL/OFF when finished.
- Reinstall flame spreader and oven bake burner cover.

Check Operation of Oven Broil Burner

- Close the oven door.
- Press the BROIL pad.
- Press the START pad.

The oven burner should light within 8 seconds. Under certain conditions, it may take the burner up to 50 to 60 seconds to light. Refer to the Use and Care Guide for proper operation of the oven controls.

Adjust Oven Broil Burner Flame (if needed)

Look through oven window to check broil burner for proper flame. This flame should have a 1/2" (1.3 cm) long inner cone of bluish-green, with an outer mantle of dark blue, and should be clean and soft in character. No yellow tips, blowing or lifting of flame should be present.

If flame needs to be adjusted:

- Loosen the lock screw on the air shutter located at the rear of the broil burner.
- Adjust the air shutter as needed.
- Tighten lock screw.

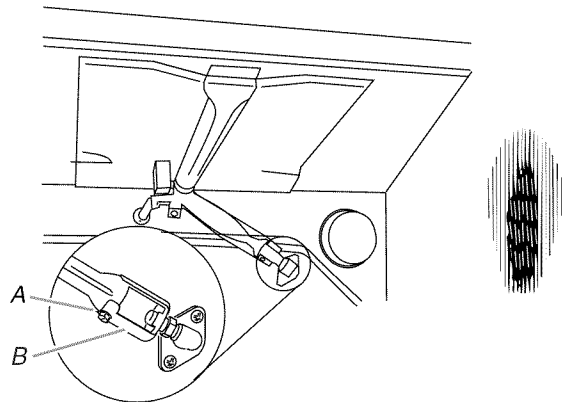

A. Lock screw
B. Air shutter

- Press CANCEL/OFF when finished.

Replace Oven Racks and Warming Drawer

Replace oven racks in oven cavity. Replace warming drawer.

To Replace Warming Drawer:

- Insert warming drawer into slide rails on sides of drawer opening.
- Lift front of drawer slightly and push firmly to close drawer.

Storage Drawer

The storage drawer can be removed. Before removing, check that the storage drawer is cool and empty. A flat-blade screwdriver will be needed for removal.

To Remove:

1. Pull the storage drawer forward to the drawer stop. Push the drawer back approximately 1" (2.5 cm).
It will be necessary to disengage the storage drawer one side at a time.
2. Insert a flat-blade screwdriver through the opening in the side of the storage drawer, placing the screwdriver tip on the outside of the drawer clip.

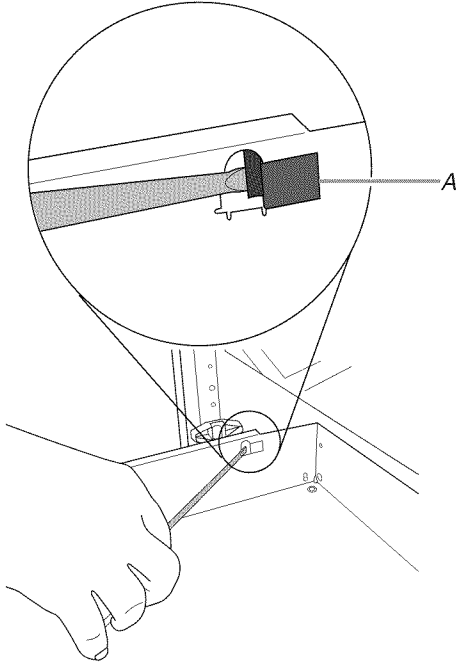

A. Drawer clip

3. Depress the drawer clip by pressing the screwdriver handle toward the side of the storage drawer.

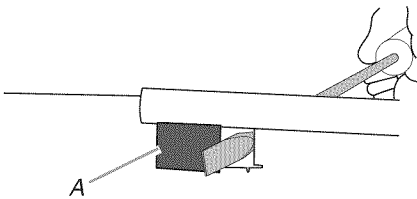

A. Drawer clip - view from outside of storage drawer

4. Gently pull forward on the storage drawer until the depressed clip clears the drawer glide.
5. Repeat steps 2-4 for the other side of the storage drawer.
6. Lift up the back of the storage drawer and remove.

To Replace:

1. Lift up the back of the storage drawer and place it inside the range in its fully forward position.
2. Lift up the front of the storage drawer to a level position.
3. Slowly push the storage drawer into the range until the drawer side rails engage with the gap in the drawer glides.

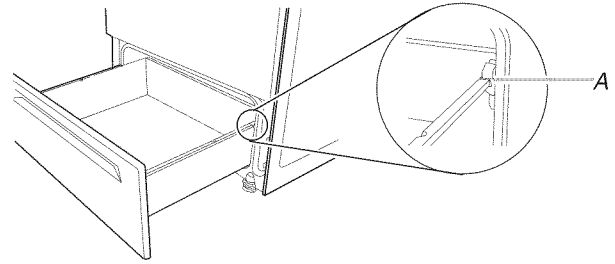

A. Engage drawer glide.

4. Once the storage drawer is fully engaged on both sides, slide the drawer back into the closed position.
5. **NOTE:** When you are removing and replacing the storage drawer, a slight push may be needed to move the drawer stop notch past the drawer glides.

Complete Installation

1. Check that all parts are now installed. If there is an extra part, go back through the steps to see which step was skipped.
2. Check that you have all of your tools.
3. Dispose of/recycle all packaging materials.
4. Check that the range is level. See "Level Range."
5. Use a mild solution of liquid household cleaner and warm water to remove waxy residue caused by shipping material. Dry thoroughly with a soft cloth. For more information, see the "Range Care" section of the Use and Care Guide.
6. Read the Use and Care Guide.
7. Turn on surface burners and oven. See the Use and Care Guide for specific instruction on range operation.

If range does not operate, check the following:

- Household fuse is intact and tight, or circuit breaker has not tripped.
 - Range is plugged into a grounded 3 prong outlet.
 - Electrical supply is connected.
 - See "Troubleshooting" in the Use and Care Guide.
8. When the range has been on for 5 minutes, check for heat. If the range is cold, turn off the range and check that the gas supply line shutoff valve is open.
 - If the gas supply line shutoff valve is closed, open it, then repeat the 5-minute test as outlined above.
 - If the gas supply line shutoff valve is open, press the CANCEL button on the oven control panel and contact a qualified technician.

If you need Assistance or Service:

Please reference the "Assistance or Service" section of the Use and Care Guide or contact the dealer from whom you purchased your range.

GAS CONVERSIONS

Gas conversions from Natural gas to LP gas or from LP gas to Natural gas must be done by a qualified installer.

⚠ WARNING



Explosion Hazard

Use a new CSA International approved gas supply line.

Install a shut-off valve.

Securely tighten all gas connections.

If connected to LP, have a qualified person make sure gas pressure does not exceed 14" (36 cm) water column.

Examples of a qualified person include:

licensed heating personnel,
authorized gas company personnel, and
authorized service personnel.

Failure to do so can result in death, explosion, or fire.

LP Gas Conversion

⚠ WARNING



Tip Over Hazard

A child or adult can tip the range and be killed.

Connect anti-tip bracket to rear range foot.

Reconnect the anti-tip bracket, if the range is moved.

Failure to follow these instructions can result in death or serious burns to children and adults.

1. Turn the manual shutoff valve to the closed position.

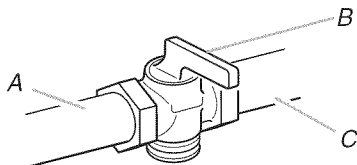

A. To range
B. Manual shutoff valve "closed" position
C. Gas supply line

2. Unplug range or disconnect power.

To Convert Gas Pressure Regulator

1. Remove storage drawer or warming drawer. See "Replace Oven Racks and Warming Drawer" section.
2. Locate gas pressure regulator at rear of storage or warming drawer compartment.

NOTE: On models with a warming drawer, an access cover must be removed to access the gas pressure regulator.

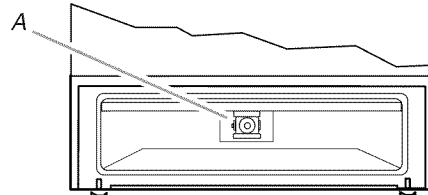

A. Gas pressure regulator

IMPORTANT: Do not remove the gas pressure regulator.

3. Remove plastic cover from gas pressure regulator cap.
4. Turn gas pressure regulator cap counterclockwise with a $\frac{5}{8}$ " combination wrench to remove.

NOTE: Do not remove the spring beneath the cap.

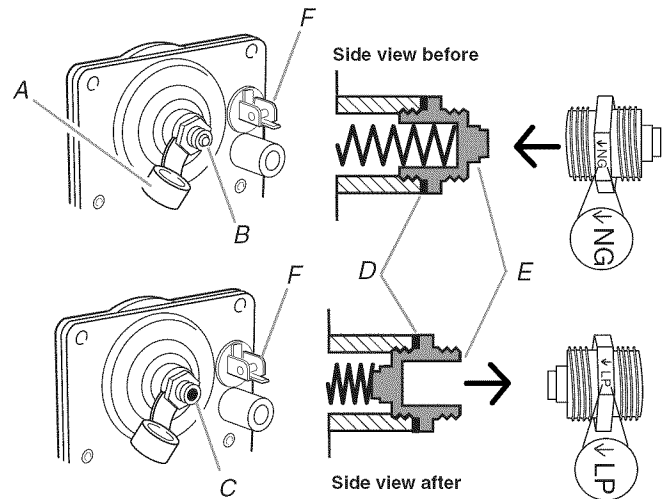

A. Plastic cover
B. Gas pressure regulator cap with solid end facing out
C. Gas pressure regulator cap with hollow end facing out
D. Washer
E. Gas pressure regulator cap
F. Gas regulator shutoff valve (shown in the "open" position)

5. Turn over the gas pressure regulator cap and reinstall on regulator so that the hollow end faces out and the marking "<- LP" is facing the direction shown in the above drawing.
6. Replace plastic cover over gas pressure regulator cap.

To Convert Surface Burners

1. Remove burner cap.
2. Using a Phillips screwdriver, remove the burner base.

NOTE: Reinstall one of the screws through the range cooktop to hold the orifice spud holder in place while removing and replacing the orifice spuds.

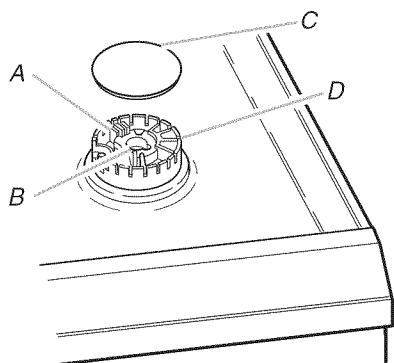

A. Igniter electrode
B. Gas tube opening
C. Burner cap
D. Burner base

3. Apply masking tape to the end of a 7 mm ($\frac{9}{32}$ ") nut driver to help hold the gas orifice spud in the nut driver while changing it. Press nut driver down onto the gas orifice spud and remove by turning it counterclockwise and lifting out. Set gas orifice spud aside.

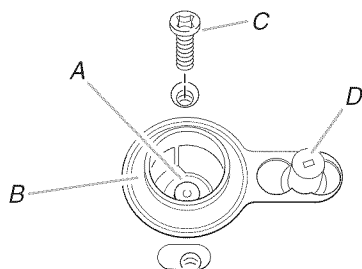

A. Orifice spud
B. Orifice spud holder
C. Screw
D. Spark electrode

4. Remove the cardboard orifice spud holder located on the back of the range near the gas inlet. Gas orifice spuds are stamped with a number, marked with 1 color dot, and have a groove in the hex area. Replace the Natural gas orifice spud with the correct LP gas orifice spud.

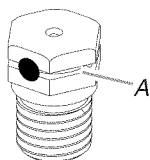

A. LP groove

Refer to the following chart for correct LP gas orifice spud placement.

LP Gas Orifice Spud Chart for Surface Burners

Burner Rating	Color	Size	ID Number
14,000 BTU	Yellow/Orange	1.07 mm	L107
11,000 BTU	Yellow/Brown	0.99 mm	L99
8,000 BTU	Yellow/Black	0.85 mm	L85
5,000 BTU	Yellow/White	0.70 mm	L70

NOTE: Refer to the Model Number and Serial Number Plate located on the oven frame behind the top left side of the oven door for proper sizing of spuds for each burner location.

5. Place Natural gas orifice spuds in the cardboard orifice spud holder.
6. Replace the burner base using both screws.
7. Replace burner cap.
8. Repeat steps 1-7 for the remaining burners.

To Convert Oven Bake Burner

1. Remove oven racks.
2. Use a $\frac{1}{2}$ " combination wrench to turn the orifice hood down snug onto pin (about 2 to $2\frac{1}{2}$ turns).

IMPORTANT: Do not overtighten.

The oven bake burner flame cannot be properly adjusted if this conversion is not made. See "Adjust Oven Bake Burner Flame" in the "Electronic Ignition System" section.

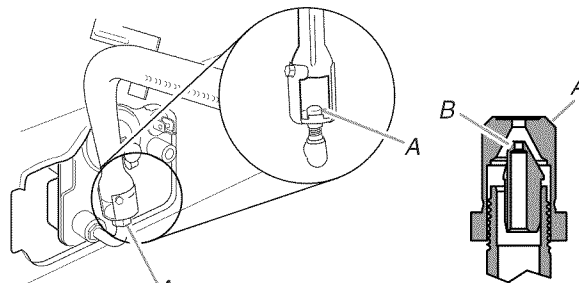

A. Orifice hood
B. Pin

To Convert Oven Broil Burner

Use a $\frac{1}{2}$ " combination wrench to turn the orifice hood down snug onto the pin (about 2 to $2\frac{1}{2}$ turns).

IMPORTANT: Do not overtighten.

The oven broil burner flame cannot be properly adjusted if this conversion is not made. See "Adjust Oven Broil Burner Flame" in the "Electronic Ignition System" section.

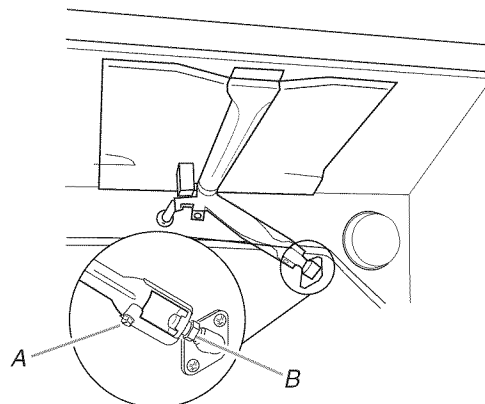

A. Lock screw
B. Orifice hood

Complete Installation

1. Refer to the "Make Gas Connection" section for properly connecting the range to the gas supply.
2. Refer to the "Electronic Ignition System" section for proper burner ignition, operation, and burner flame adjustments.

IMPORTANT: You may have to adjust the "LO" setting for each cooktop burner.

Checking for proper cooktop, bake and broil burner flame is very important. The small inner cone should have a very distinct blue flame $\frac{1}{4}$ " (0.64 cm) to $\frac{1}{2}$ " (1.3 cm) long. The outer cone is not as distinct as the inner cone. LP gas flames have a slightly yellow tip.

3. Refer to "Complete Installation" in the "Installation Instructions" section of this manual to complete this procedure.

Natural Gas Conversion

! WARNING



Tip Over Hazard

A child or adult can tip the range and be killed.

Connect anti-tip bracket to rear range foot.

Reconnect the anti-tip bracket, if the range is moved.

Failure to follow these instructions can result in death or serious burns to children and adults.

1. Turn the manual shutoff valve to the closed position.

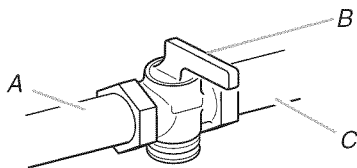

A. To range

B. Manual shutoff valve "closed" position

C. Gas supply line

2. Unplug range or disconnect power.

To Convert Gas Pressure Regulator

1. Remove storage drawer or warming drawer. See "Replace Oven Racks and Warming Drawer" section.
2. Locate gas pressure regulator at rear of storage or warming drawer compartment.

NOTE: On models with a warming drawer, an access cover must be removed to access the gas pressure regulator.

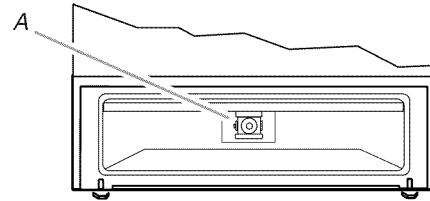

A. Gas pressure regulator

IMPORTANT: Do not remove the gas pressure regulator.

3. Remove plastic cover from gas pressure regulator cap.
4. Turn gas pressure regulator cap counterclockwise with a $\frac{3}{8}$ " combination wrench to remove.

NOTE: Do not remove the spring beneath the cap.

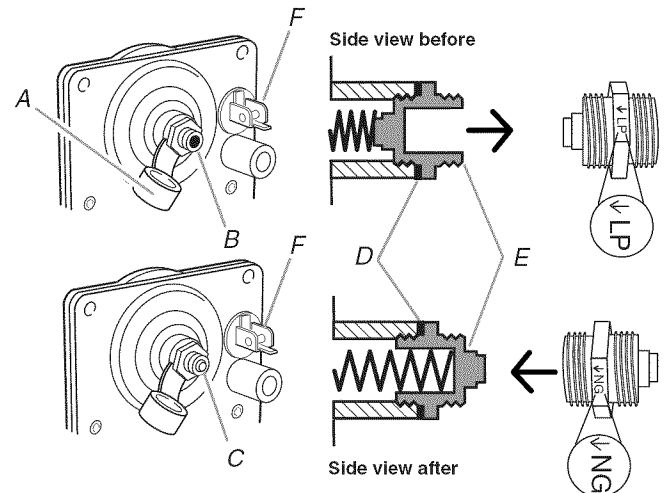

A. Plastic cover

B. Gas pressure regulator cap with hollow end facing out

C. Gas pressure regulator cap with solid end facing out

D. Washer

E. Gas pressure regulator cap

F. Gas regulator shutoff valve (shown in the "open" position)

5. Turn over the gas pressure regulator cap and reinstall on regulator so that the solid end faces out and the marking "<- NG" is facing the direction shown in the above drawing.
6. Replace plastic cover over gas pressure regulator cap.

To Convert Surface Burners

1. Remove burner cap.
2. Using a Phillips or Quadrex® screwdriver, remove the burner base.

NOTE: Reinstall one of the screws through the range cooktop to hold the orifice spud holder in place while removing and replacing the orifice spuds.

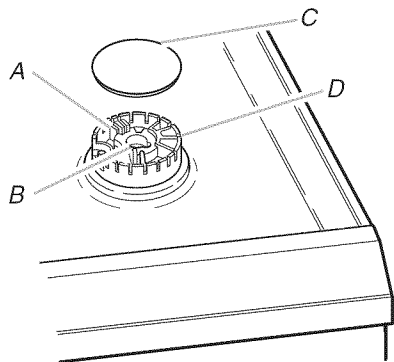

A. Igniter electrode
B. Gas tube opening
C. Burner cap
D. Burner base

3. Apply masking tape to the end of a 7 mm ($\frac{9}{32}$ ") nut driver to help hold the gas orifice spud in the nut driver while changing it. Press nut driver down onto the gas orifice spud and remove by turning it counterclockwise and lifting out. Set gas orifice spud aside.

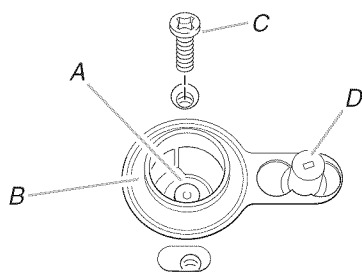

A. Orifice spud
B. Orifice spud holder
C. Screw
D. Spark electrode

4. Gas orifice spuds are stamped with a number on the side. Replace the LP gas orifice spud with the correct Natural gas orifice spud.

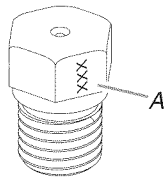

A. Stamped number

Refer to the following chart for the correct Natural gas orifice spud placement.

Natural Gas Orifice Spud Chart

Burner Rating	Color	Size	ID Number
17,000 BTU	Red/Magenta	2.10 mm	N210
15,500 BTU	Red/Black	2.00 mm	N200
14,200 BTU	Red/Orange	1.90 mm	N190
13,000/13,500 BTU	Red/Blue	1.85 mm	N185
12,000/12,500 BTU	Red/Yellow	1.80 mm	N180
9,500 BTU	Red/Brown	1.55 mm	N155
8,000 BTU	Red/White	1.40 mm	N140
5,000 BTU	Red/Brass	1.10 mm	N110

NOTE: Refer to the Model Number and Serial Number Plate located on the oven frame behind the top left side of the oven door for proper sizing of spuds for each burner location.

5. Place LP gas orifice spuds in plastic parts bag for future use and keep with package containing literature.
6. Replace the burner base using both screws.
7. Replace burner cap.
8. Repeat steps 1-7 for the remaining burners.

To Convert Oven Bake Burner

1. Remove oven racks.
2. Use a $\frac{1}{2}$ " combination wrench to loosen the orifice hood away from the pin (about 2 to 2½ turns). The oven bake burner flame cannot be properly adjusted if this conversion is not made. See "Adjust Oven Bake Burner Flame" in the "Electronic Ignition System" section.

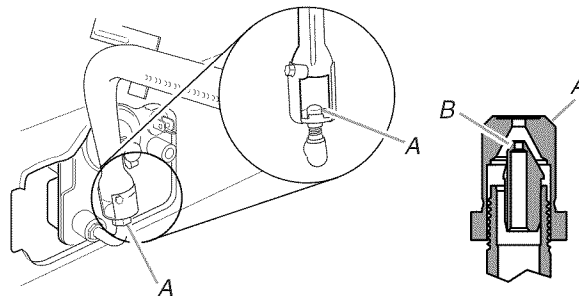

A. Orifice hood
B. Pin

To Convert Oven Broil Burner

Use a ½" combination wrench to loosen the orifice hood away from the pin (about 2 to 2½ turns). The oven broil burner flame cannot be properly adjusted if this conversion is not made. See "Adjust Oven Broil Burner Flame" in the "Electronic Ignition System" section.

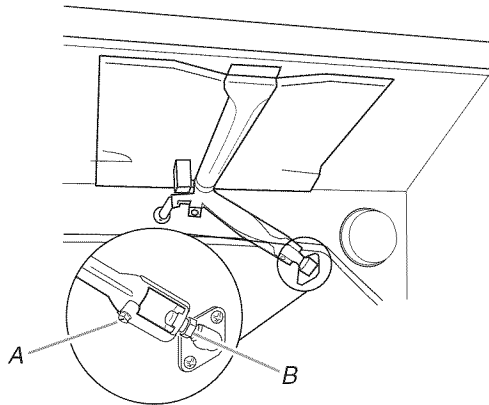

A. Lock screw
B. Orifice hood

Complete Installation

1. Refer to the "Make Gas Connection" section for properly connecting the range to the gas supply.
2. Refer to the "Electronic Ignition System" section for proper burner ignition, operation, and burner flame adjustments.
IMPORTANT: You may have to adjust the "LO" setting for each cooktop burner.
Checking for proper cooktop, bake and broil burner flame is very important. Natural gas flames do not have yellow tips.
3. Refer to "Complete Installation" in the "Installation Instructions" section of this manual to complete this procedure.

ANTI-TIP BRACKET TEMPLATE

Cut on dotted lines and place the left edge against the left side cabinet and the top edge against the rear wall.

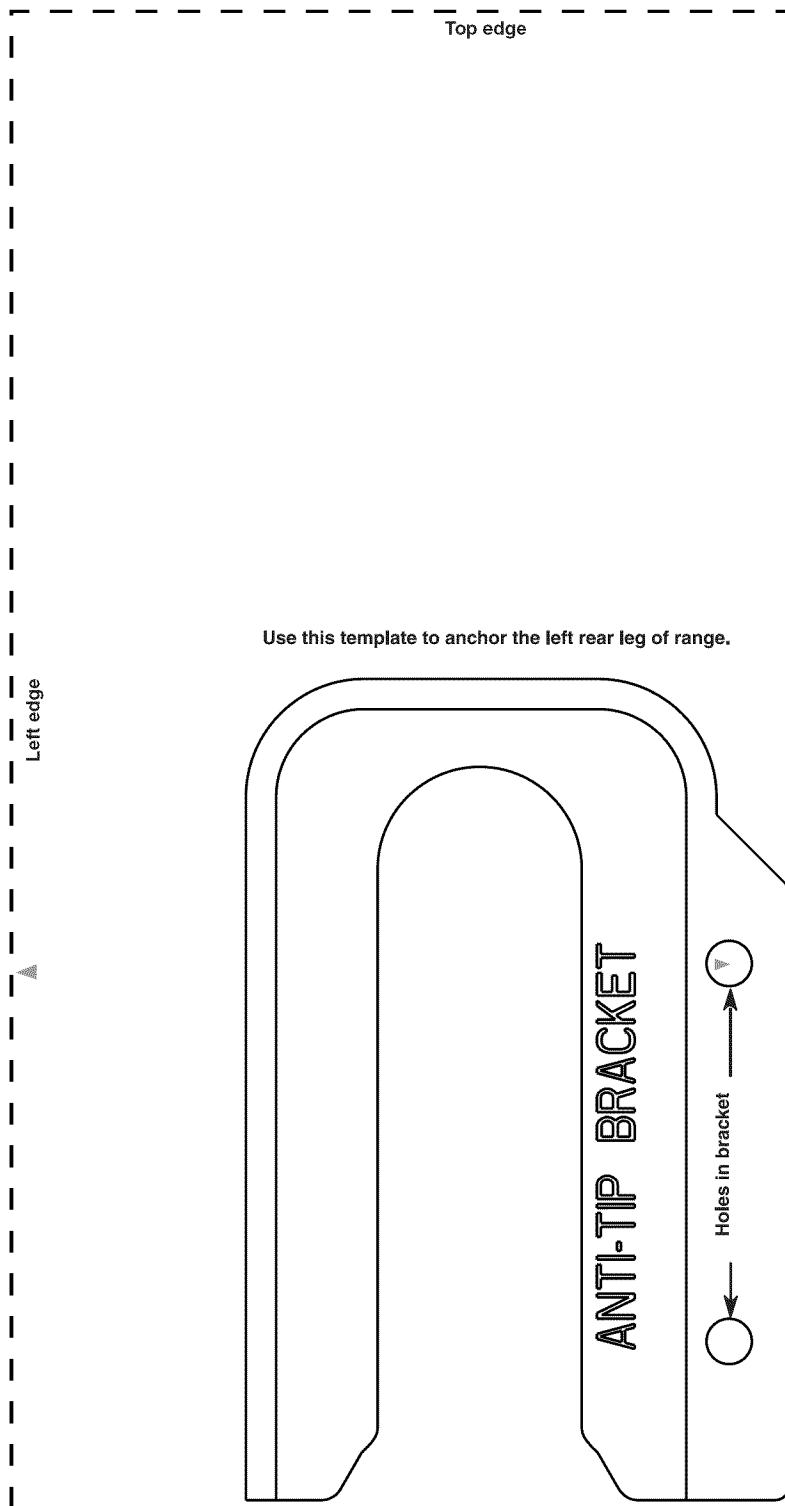

Use this template to anchor the left rear leg of range.

