

Home Theater Package
Pack Numérique Home Cinéma

YHT-494

***(HTR-3063 + NS-BR300 +
NS-B285 + NS-SW280)***

Owner's Manual
Mode d'emploi

IMPORTANT SAFETY INSTRUCTIONS

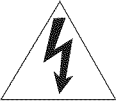

CAUTION

RISK OF ELECTRIC SHOCK

DO NOT OPEN

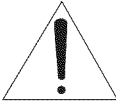

CAUTION: TO REDUCE THE RISK OF ELECTRIC SHOCK, DO NOT REMOVE COVER (OR BACK). NO USER-SERVICEABLE PARTS INSIDE. REFER SERVICING TO QUALIFIED SERVICE PERSONNEL.

• Explanation of Graphical Symbols

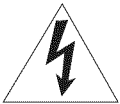

The lightning flash with arrowhead symbol, within an equilateral triangle, is intended to alert you to the presence of uninsulated "dangerous voltage" within the product's enclosure that may be of sufficient magnitude to constitute a risk of electric shock to persons.

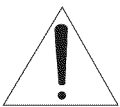

The exclamation point within an equilateral triangle is intended to alert you to the presence of important operating and maintenance (servicing) instructions in the literature accompanying the appliance.

IMPORTANT

Please record the serial number of this unit in the space below.

MODEL:

Serial No.:

The serial number is located on the rear of the unit. Retain this Owner's Manual in a safe place for future reference.

1. Read these instructions.
2. Keep these instructions.
3. Heed all warnings.
4. Follow all instructions.
5. Do not use this apparatus near water.
6. Clean only with dry cloth.
7. Do not block any ventilation openings. Install in accordance with the manufacturer's instructions.
8. Do not install near any heat sources such as radiators, heat registers, stoves, or other apparatus (including amplifiers) that produce heat.
9. Do not defeat the safety purpose of the polarized or grounding-type plug. A polarized plug has two blades with one wider than the other. A grounding type plug has two blades and a third grounding prong. The wide blade or the third prong are provided for your safety. If the provided plug does not fit into your outlet, consult an electrician for replacement of the obsolete outlet.
10. Protect the power cord from being walked on or pinched particularly at plugs, convenience receptacles, and the point where they exit from the apparatus.
11. Only use attachments/accessories specified by the manufacturer.
12. Use only with the cart, stand, tripod, bracket, or table specified by the manufacturer, or sold with the apparatus. When a cart is used, use caution when moving the cart/apparatus combination to avoid injury from tip-over. 
13. Unplug this apparatus during lightning storms or when unused for long periods of time.
14. Refer all servicing to qualified service personnel. Servicing is required when the apparatus has been damaged in any way, such as power-supply cord or plug is damaged, liquid has been spilled or objects have fallen into the apparatus, the apparatus has been exposed to rain or moisture, does not operate normally, or has been dropped.

FCC INFORMATION (for US customers)

1 IMPORTANT NOTICE: DO NOT MODIFY THIS UNIT!

This product, when installed as indicated in the instructions contained in this manual, meets FCC requirements. Modifications not expressly approved by Yamaha may void your authority, granted by the FCC, to use the product.

2 IMPORTANT: When connecting this product to accessories and/or another product use only high quality shielded cables. Cable/s supplied with this product **MUST** be used. Follow all installation instructions. Failure to follow instructions could void your FCC authorization to use this product in the USA.

3 NOTE: This product has been tested and found to comply with the requirements listed in FCC Regulations, Part 15 for Class "B" digital devices. Compliance with these requirements provides a reasonable level of assurance that your use of this product in a residential environment will not result in harmful interference with other electronic devices. This equipment generates/uses radio frequencies and, if not installed and used according to the instructions found in the users manual, may cause interference harmful to the operation of other electronic devices.

Compliance with FCC regulations does not guarantee that interference will not occur in all installations. If this product is found to be the source of interference, which can be determined by turning the unit "OFF" and "ON", please try to eliminate the problem by using one of the following measures:

Relocate either this product or the device that is being affected by the interference.

Utilize power outlets that are on different branch (circuit breaker or fuse) circuits or install AC line filter/s.

In the case of radio or TV interference, relocate/reorient the antenna. If the antenna lead-in is 300 ohm ribbon lead, change the lead-in to coaxial type cable.

If these corrective measures do not produce satisfactory results, please contact the local retailer authorized to distribute this type of product. If you can not locate the appropriate retailer, please contact Yamaha Electronics Corp., U.S.A. 6660 Orangethorpe Ave., Buena Park, CA 90620.

The above statements apply **ONLY** to those products distributed by Yamaha Corporation of America or its subsidiaries.

Precautions

Please read the following operating precautions before use. Yamaha will not be held responsible for any damage and/or injury caused by not following the cautions below.

1. To assure the finest performance, please read this manual carefully. Keep it in a safe place for future reference.
2. Install the speakers in a cool, dry, clean place – away from windows, sources of heat, sources of excessive vibration, dust, moisture or cold. Avoid sources of electrical humming (e.g., transformers and motors). To prevent fire or electric shock, do not expose the speakers to rain or water.
3. To prevent the enclosure from warping or discoloring, do not expose the speakers to direct sunlight or excessive humidity.
4. Avoid installing the speakers where foreign objects may fall onto them and/or where they may be exposed to liquid dripping or splashing.
5. Do not place the following objects on top of the speakers:
 - Other components, as they might damage or discolor the surface of the speakers.
 - Burning objects (e.g., candles), as they might cause fire, damage to the speakers or personal injury.
 - Containers of liquid, as they might spill and cause electric shock to the user or damage to the speakers.
6. Do not place the speakers where they are liable to be knocked over or struck by falling objects. Stable placement will also ensure better sound performance.
7. Placing the speakers on the same shelf or rack as the turntable can result in feedback.
8. Any time you note distortion, reduce the volume control on your amplifier to lower setting. Never allow your amplifier to be driven into “clipping”. Otherwise, the speakers may be damaged.
9. When using an amplifier with a rated output power higher than the nominal input power of the speakers, care should be taken not to exceed the maximum input of the speakers.
10. Do not attempt to clean the speakers with chemical solvents as this might damage the finish. Use a clean, dry cloth.
11. Do not attempt to modify or fix the speakers. Contact qualified Yamaha service personnel when service is needed. The cabinet should never be opened for any reason.
12. Be sure to read the “Troubleshooting” section regarding common operating errors before concluding that the speakers are faulty.
13. **Secure placement or installation is the owner’s responsibility. Yamaha is not liable for accidents caused by improper placement or installation of speakers.**

For NS-SW280

WARNING

TO REDUCE THE RISK OF FIRE OR ELECTRIC SHOCK, DO NOT EXPOSE THIS APPLIANCE TO RAIN OR MOISTURE.

1. Do not operate this unit upside down. It may overheat, possibly causing damage.
2. Do not use excessive force on switches, controls or connection wires. When moving this unit, first disconnect the power plug and the wires connected to other equipment. Never pull the wires themselves.
3. Never put a hand or a foreign object into the port located on the right side of this unit. When moving this unit, do not hold the port, as it might cause personal injury and/or damage to this unit.
4. Since this unit has a built-in power amplifier, heat radiates from the rear panel. Place the unit away from walls, allowing at least 20 cm (8") of space above, behind and on both sides of the unit to prevent fire or damage. Furthermore, do not position the unit with the rear panel facing down on the floor or other surfaces.
5. When using a humidifier, be sure to avoid condensation inside this unit by allowing enough space around the unit and avoiding excess humidification. Condensation might cause fire, damage to the unit, and/or electric shock.
6. Do not cover the rear panel of this unit with a newspaper, tablecloth, curtain, etc. to avoid obstructing heat radiation. If the temperature inside the unit rises, it may cause fire, damage to the unit, or personal injury.
7. Do not plug this unit into a wall outlet until all connections are complete.
8. The voltage to be used must match that specified on the rear panel. Using this unit with a voltage higher than specified is dangerous and may cause fire, damage to the unit, and/or personal injury. Yamaha is not responsible for damage resulting from use of this unit with a voltage other than specified.
9. Super-bass sound reproduced by this unit may cause a turntable to generate audio feedback. In this case, move the unit away from the turntable.
10. This unit may be damaged if certain sounds are continuously output at high volume level. For example, if 20 Hz–50 Hz sine waves from a test disc or bass sounds from an electronic instrument, etc. are continuously output, or if a turntable stylus touches the surface of a disc, reduce the volume level to prevent the unit from being damaged.
11. If you hear distorted noise (i.e., unnatural, intermittent “rapping” or “hammering” sounds) from this unit, reduce the volume level. Extremely loud movie soundtrack low frequency, bass-heavy sounds, or similarly loud popular music passages can damage this unit.
12. Vibration generated by super-bass sound may distort images on a TV. In this case, move the unit away from the TV set.
13. When disconnecting the power cord from the wall outlet, grasp the plug; do not pull the cord.
14. When you plan not to use this unit for a long period of time (i.e. vacation, etc.), disconnect the AC power plug from the wall outlet.
15. Install this unit near the wall outlet and where the AC power plug can be reached easily.

This unit is not disconnected from the AC power source as long as it is connected to the wall outlet, even if this unit itself is turned off. In this state, this unit is designed to consume a very small quantity of power.

FOR CANADIAN CUSTOMERS

To prevent electric shock, match wide blade of plug to wide slot and fully insert.

This Class B digital apparatus complies with Canadian ICES-003.

We Want You Listening For A Lifetime



Yamaha and the Electronic Industries Association's Consumer Electronics Group want you to get the most out of your equipment by playing it at a safe level. One that lets the sound come through loud and clear without annoying blaring or distortion – and, most importantly, without affecting your sensitive hearing. Since hearing damage from loud sounds is often undetectable until it is too late, Yamaha and the Electronic Industries Association's Consumer Electronics Group recommend you to avoid prolonged exposure from excessive volume levels.

Contents

Package contents.....	1	Using the subwoofer.....	6
Positioning the speakers	1	Wall-mounting the speakers	7
Connecting the speakers and antennas	2	Troubleshooting	8
Connecting AV components	4	Specifications	8

Thank you for choosing the Yamaha YHT-494 Home Theater Package.

The Yamaha YHT-494 Home Theater Package includes everything you need to add great sound to your home theater. By following the instructions in this manual, you'll have your home theater set up in no time and be enjoying music and movies like never before. See also the AV Receiver's owner's manual for full instructions and precautions for AV Receiver.

Package contents

Make sure the package contains the following items.

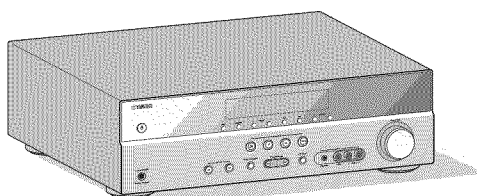

AV Receiver (HTR-3063)*
* See the AV Receiver's owner's manual for a list of the items supplied with the AV Receiver.

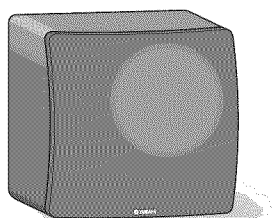

Subwoofer (NS-SW280)

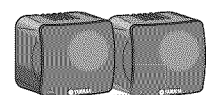

Surround speakers (NS-B285)

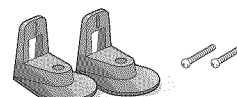

Stands and screws for surround speakers (NS-B285)

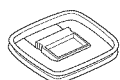

AM antenna



FM antenna



Front/center speaker (NS-BR300)

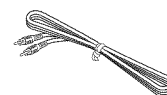

Subwoofer cable 5 m (16 ft.) x1

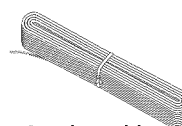

Speaker cable 25 m (82 ft.) x1

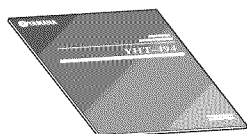

Owner's manual



Stands and screws for front/center speaker (NS-BR300)



Non-skid pads for front/center speaker (NS-BR300)



Mounting template for front/center speaker (NS-BR300)

Note

- Only the items required to complete the installation explained in this manual are shown here.

Positioning the speakers

Before you connect the speakers, place each speaker in its respective location. Speaker positioning is very important as it affects the overall sound quality of the system. Place the speakers in locations that will optimize the sound quality at your listening position. Refer to the illustration.

The position of the subwoofer is not as critical as the position of the other speakers because sub-bass sounds are not very directional.

Notes

- Placing the speakers too close to a CRT-type TV may impair the picture color or cause a buzzing noise. In this case, move the speakers at least 20 cm (8") away from the TV. This is not an issue with LCD and plasma TVs.
- See page 7 for information on wall-mounting the speakers.

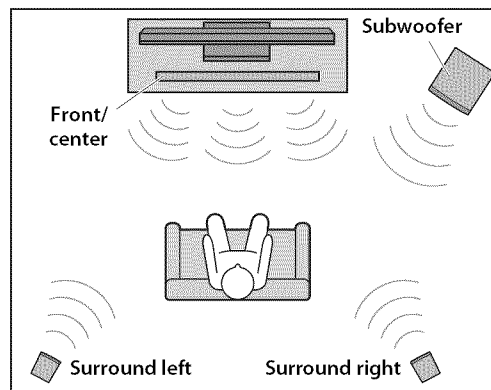

Connecting the speakers and antennas

1 Preparing the cables and speakers

Once you've positioned the speakers, you'll need to cut the 25-meter (82 ft.) speaker cable to make three cables for connecting the front/center speaker and two cables for the surround speakers.

- 1 Cut the included speaker cable to suitable lengths for the front/center speaker and surround speakers. You need five cables.
- 2 Remove about 10 mm (3/8") of insulation from the end of each speaker cable.
- 3 Twist the bare wires tightly.

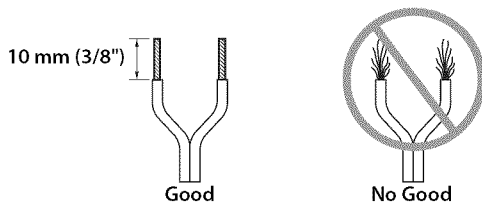

Notes

- Make the speaker cables as short as possible. Do not bundle or roll up excess cable.
- Twist the bare wires tightly so the individual strands are not splayed.
- Be careful not to injure yourself while preparing the speaker cables.

- 4 Connect the speaker cables to the front/center speaker (NS-BR300) and surround speakers (NS-B285).

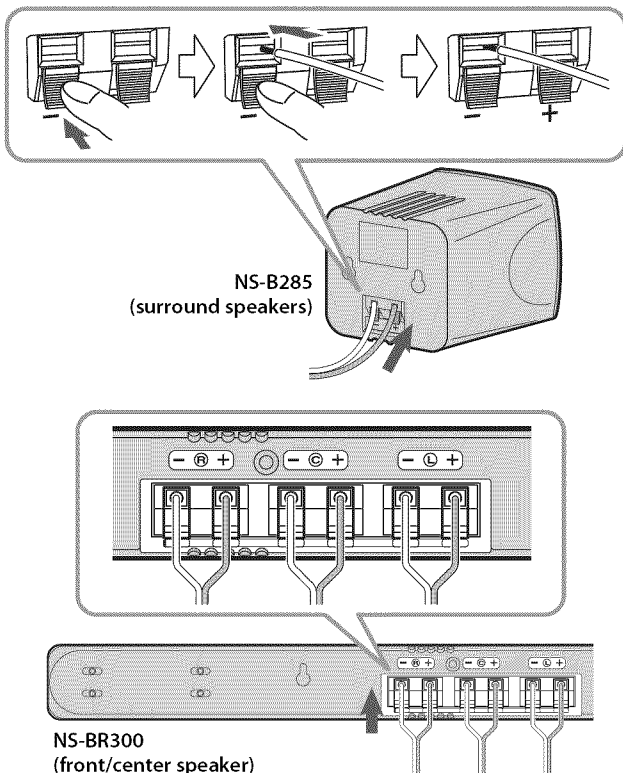

Attaching the speaker stands

Surround speakers (NS-B285)

Attach the included speaker stands with screws when placing the surround speakers on a flat surface, as shown below.

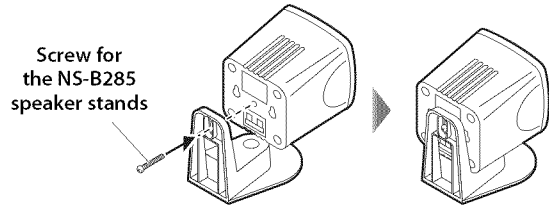

Front/center speaker (NS-BR300)

If you place the front/center speaker (NS-BR300) at the base of your TV, attach the included stands. If you use it without the stands, affix the included non-skid pads.

Attaching the stands

On the rear of the front/center speaker (NS-BR300), there are four screw holes at each end for attaching the stands at a suitable height and width for your TV.

Note

Make sure the front/center speaker does not obstruct the remote control sensor on the front of your TV.

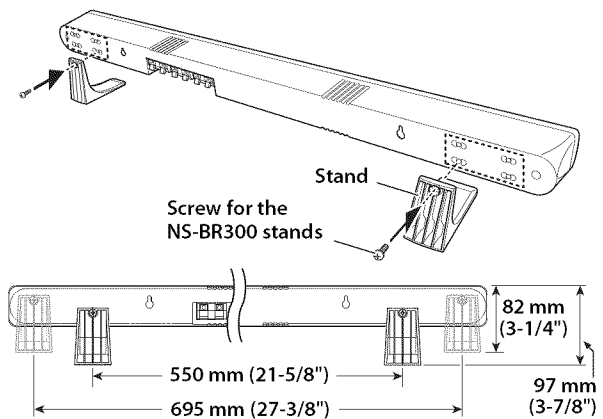

Affixing the non-skid pads

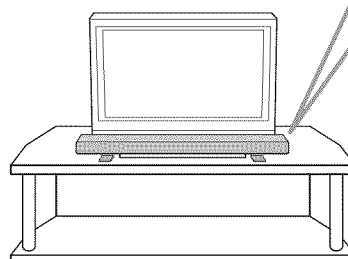
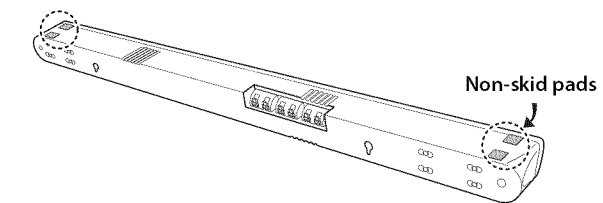

Caution: Disconnect all components from AC outlets before proceeding.

2 Connecting the front/center speaker (NS-BR300)

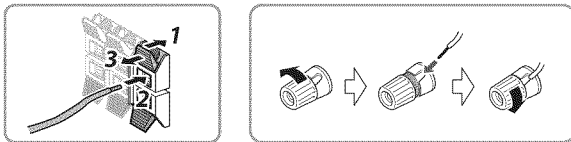
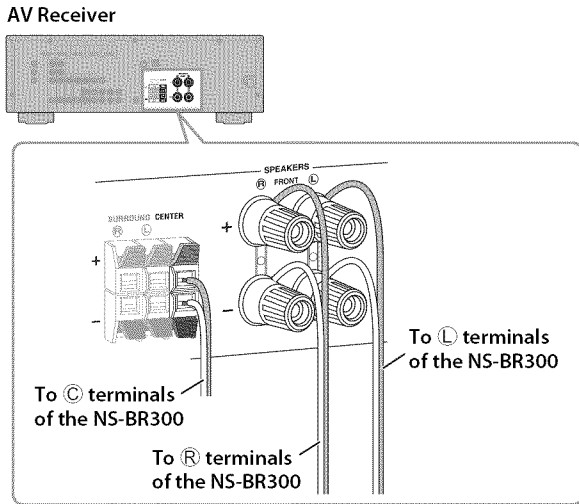

Connect the NS-BR300 speaker cables to the AV Receiver. Make sure you connect the speaker with the correct polarity: positive (+) terminals to positive (+) terminals, and negative (-) terminals to negative (-) terminals.

3 Connecting the surround speakers (NS-B285)

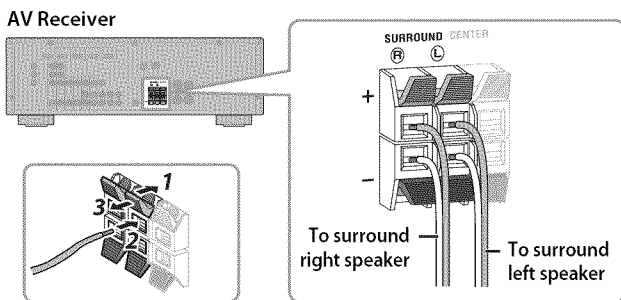

Connect the surround speaker cables to the AV Receiver. Make sure you connect the speakers with the correct polarity: positive (+) terminals to positive (+) terminals, and negative (-) terminals to negative (-) terminals.

4 Connecting the subwoofer (NS-SW280)

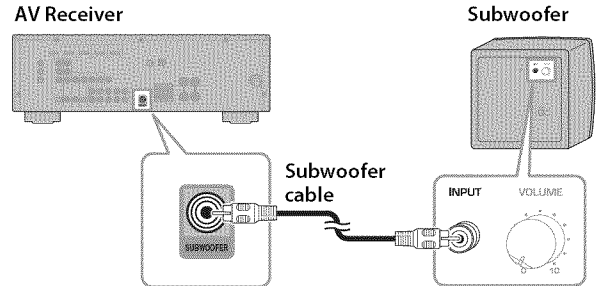

Use the included subwoofer cable to connect the subwoofer's INPUT jack to the AV Receiver's SUBWOOFER jack. See "Using the subwoofer" on page 6 for more information about the subwoofer and its operation.

5 Connecting the antennas

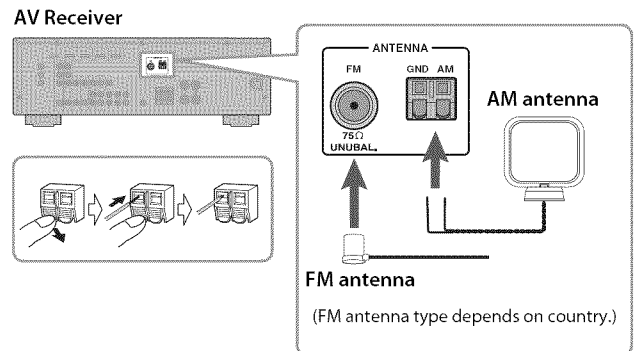

Connect the AM loop antenna and indoor FM antenna to the AV Receiver, as shown. See the AV Receiver's owner's manual for more information about connecting antennas.

Connecting AV components

Caution: Disconnect all components from AC outlets before proceeding.

1 Connecting HDMI-capable components

If your TV and DVD player or satellite/cable set-top box have HDMI jacks, you can connect them via the AV Receiver. Using HDMI cables (not included), connect the AV Receiver's HDMI OUT jack to an HDMI input on your TV, and connect your DVD player and satellite/cable set-top box to the AV Receiver's HDMI 1 (BD/DVD) and HDMI 2 jacks, respectively, as shown.

Refer to the AV Receiver's owner's manuals for more information about HDMI.

■ Connecting your TV

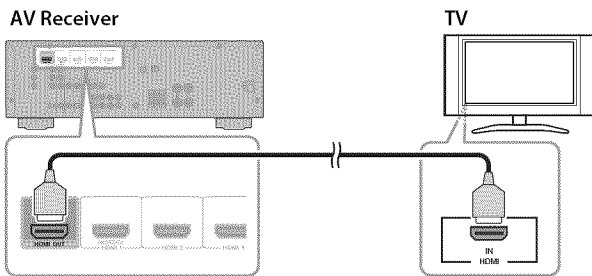

■ Connecting your DVD player

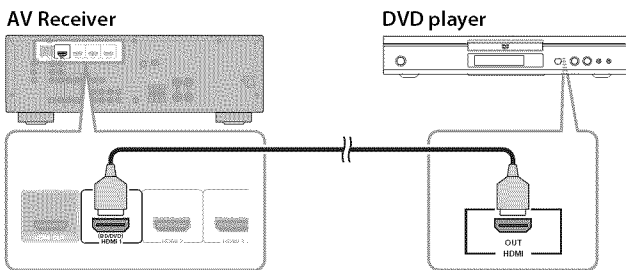

■ Connecting your satellite/cable set-top box

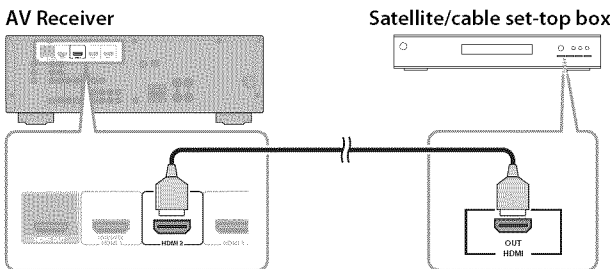

2 Connecting your TV for audio output

You can listen to TV audio through the AV Receiver and speakers by connecting an audio output on your TV to an audio input on the AV Receiver with, for example, an optical digital audio cable (not included), as shown.

To listen to TV audio, select the appropriate input source on the AV Receiver.

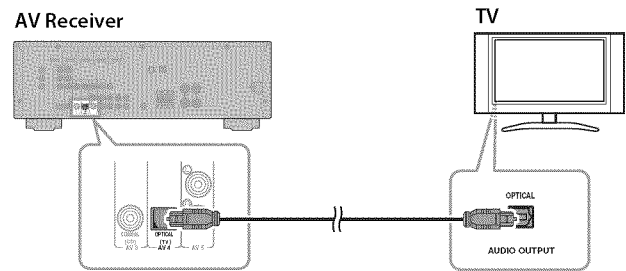

3 Connecting your DVR/VCR

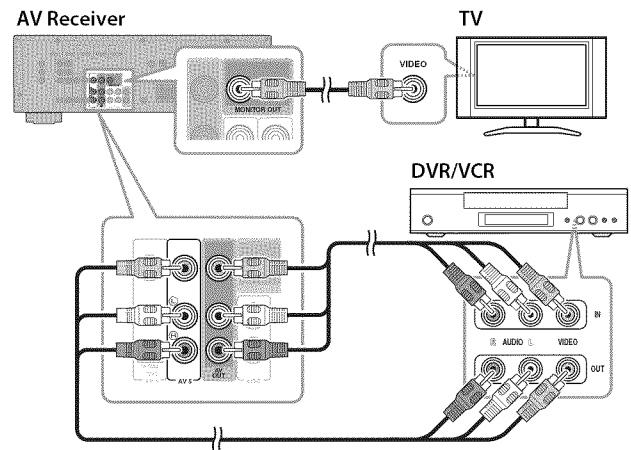

Use a video pin cable (not included) to connect the AV Receiver's MONITOR OUT jack to a composite video input on your TV, as shown.

Use AV pin cables (not included) to connect your DVR (digital video recorder) or VCR to the AV Receiver's AV 5 and AV OUT jacks, as shown.

4 Connecting your CD player

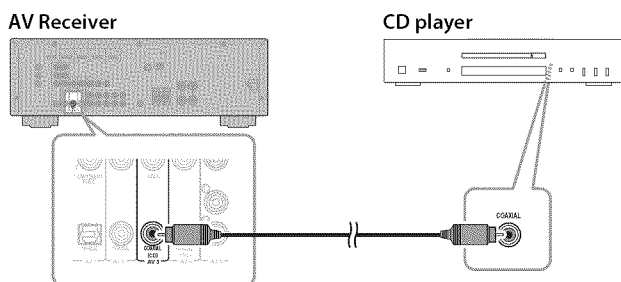

Use an audio pin cable (not included) to connect your CD player to the AV Receiver's AV 3 COAXIAL(CD) jack, as shown.

■ Almost Finished

- Connect the AV Receiver, subwoofer, and your other AV components to suitable AC outlets.
- Turn on the AV Receiver first, then the subwoofer and your other AV components.
- Install the batteries in the AV Receiver's remote control.
- The optimum crossover frequency setting on the AV Receiver is 160 Hz.
- See the relevant owner's manuals for full operating instructions.



Time to enjoy your Yamaha Home Theater Package!

Now, relax and enjoy the great sound of your Yamaha Home Theater Package.

5 Connecting your portable music player

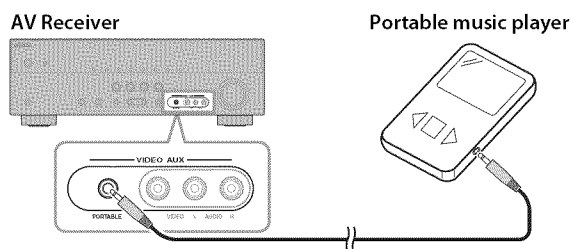

Use a 3.5 mm stereo mini plug cable (not included) to connect your portable music player to the AV Receiver's PORTABLE jack (on the front panel), as shown.

If your AV Receiver has a DOCK jack (U.S.A. and Canada models), you can connect a Yamaha Universal Dock for iPod, such as the YDS-12, or a Yamaha Bluetooth Wireless Audio Receiver, such as the YBA-10 (both sold separately). See the AV Receiver's Owner's Manual for more information.

Using the subwoofer

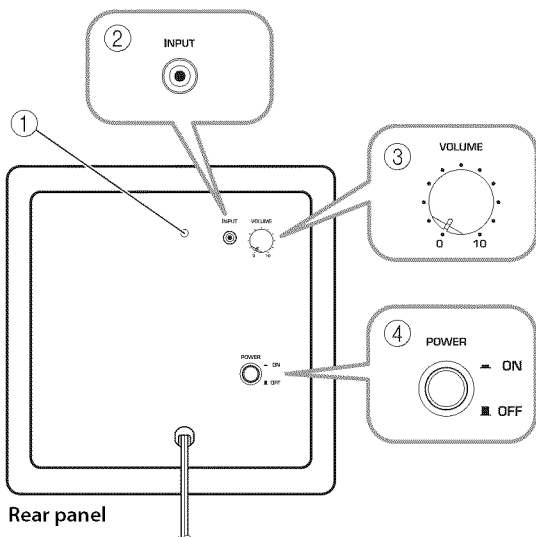

① Power indicator

Lights up when the POWER switch is set to ON; goes off when the POWER switch is set to OFF.

② INPUT jack

Input jack for connecting the line-level subwoofer output on your amplifier.

③ VOLUME control

Adjusts the volume of the subwoofer. Turn it clockwise to increase the volume; counterclockwise to decrease the volume.

④ POWER switch

Set this to ON to turn on the subwoofer. Set it to OFF to turn off the subwoofer.

Setting the subwoofer volume

The very first time you use the subwoofer, you need to set the volume balance between the subwoofer and the front speakers as follows.

1 Turn on your other AV components.

2 Set the subwoofer's VOLUME control to minimum (0).

3 Set the subwoofer's POWER switch to ON.

The power indicator on the rear panel lights up.

4 Play an audio source that contains low-frequency bass sounds. Set the amplifier's volume control to a suitable level.

5 Turn the subwoofer's VOLUME control up gradually until you achieve a good balance between the subwoofer and the other speakers.

Notes

- Once the subwoofer volume has been set, you can leave the subwoofer's VOLUME control set as it is and use your amplifier's volume control to adjust the volume of the entire system.
- If you replace the front/center speaker (NS-BR300) with other speakers, you will need to re-adjust the subwoofer's volume.
- The frequency characteristics graphs below show how the subwoofer and front speakers work together to provide a full-range sound.

Frequency characteristics

The following graph shows the frequency characteristics of the subwoofer (NS-SW280).

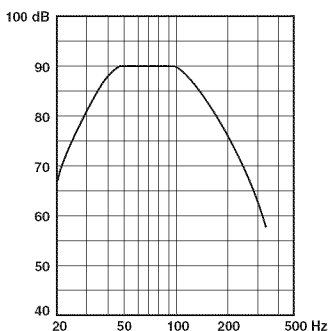

The following graph shows the combined frequency characteristics of the subwoofer (NS-SW280) and front/center speaker (NS-BR300), and surround speaker (NS-B285).

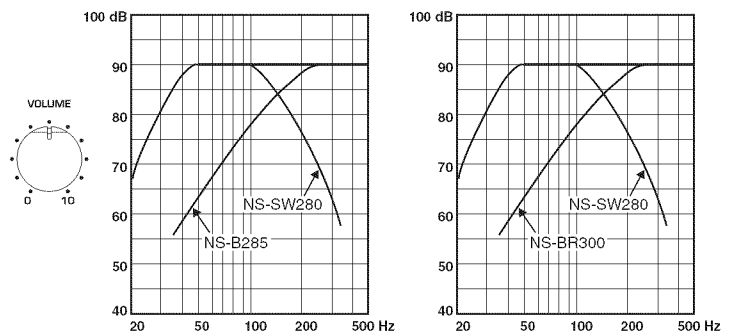

Wall-mounting the speakers

You can mount the speakers on the wall as follows.

Unless you are very competent at DIY, do not wall-mount the speaker yourself. Ask your dealer or a qualified contractor to do the installation for you. Incorrect installation may cause the speaker to fall, causing damage or injury.

• Surround speakers (NS-B285)

- 1** Install screws into a solid wall or wall support, as shown below. Use 3.5 to 4 mm (1/8") diameter self-tapping screws.
- 2** Hang each speaker by its keyhole slots onto the protruding screws.

Note

- Make sure the shaft of the screw is seated in the narrow part of the keyhole slot. Otherwise, the speaker may fall.

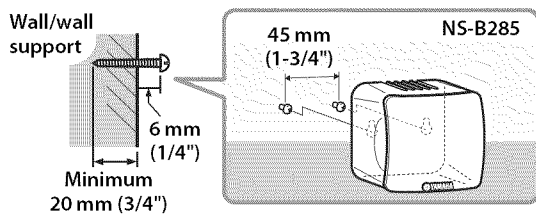

• Front/center speaker (NS-BR300)

- 1** Use tape or thumbtacks to affix the supplied mounting template to the wall, and use a pencil or other tool to mark the hole positions on the wall.

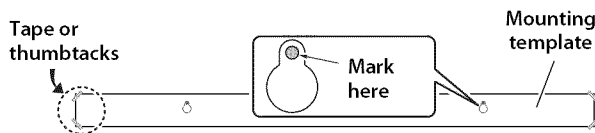

- 2** Remove the template, and then install screws, as shown below. Use 3.5 to 4 mm (1/8") diameter self-tapping screws.

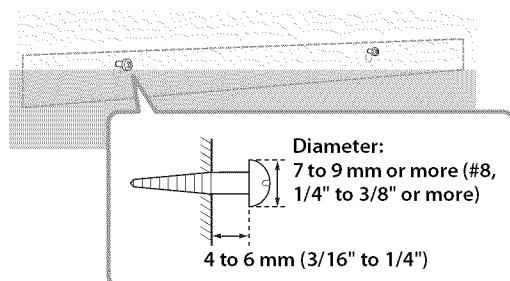

- 3** Hang the speaker by its keyhole slots onto the protruding screws.

Note

- Make sure the shaft of each screw is seated in the narrow part of each keyhole slot. Otherwise, the speaker may fall.

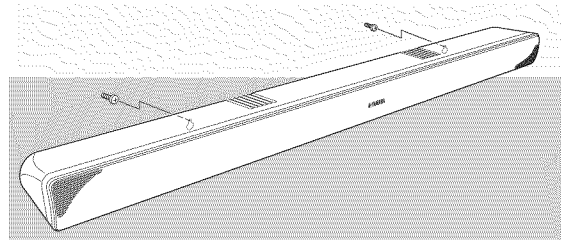

Cautions

- The front/center speaker (NS-BR300) weighs 1.5 kg (3 lbs.). The surround speakers (NS-B285) weigh 0.45 kg (1 lbs.). Do not mount the speakers on thin plywood or on walls with a soft surface material. Otherwise, the screws may pull out of the surface and the speakers may fall, causing damage or injury.
- Do not affix the speakers to walls by using nails, adhesives, or unsuitable hardware. Long-term use and vibration may cause the speakers to fall.
- To prevent tripping accidents, secure loose speaker cables to walls, floors, etc., using suitable fasteners.
- Mount the speakers at positions on the walls where people are unlikely to bump their heads.
- Attach the speakers to a rack or wall. Do not attach the speakers to walls made of weak materials, such as plaster or veneered woods. Doing so may cause the speakers to fall.
- Use commercially available screws that can support the weight of the speakers.
- Only use the screws specified for attaching the speakers. Using fasteners other than those specified, such as short screws, nails, or double-sided tape, may cause the speakers to fall.
- When connecting the speakers, secure the speaker cables so that they do not hang loose. If your foot or hand accidentally gets caught on a loose speaker cable, the speaker may fall, causing damage or injury.
- After installing each speaker, check that it's fixed securely. Yamaha accepts no responsibility whatsoever for accidents due to improper installation.

Troubleshooting

If this product doesn't work as expected, look for a possible cause below. If the issue you are experiencing is not listed, or you cannot resolve it after reading through these instructions, disconnect the power cable and contact an authorized Yamaha dealer or service center.

Issue	Possible cause	Remedy
There's no sound.	The speaker cables are not connected properly.	Make sure the speaker cables are connected properly.
The sound is very quiet.	The speaker cables are not connected properly.	Make sure the speaker cables are connected properly: L (left) to L, R (right) to R, "+" to "+" and "-" to "-".

■ Subwoofer (NS-SW280)

Issue	Possible cause	Remedy
The POWER switch is set to ON but the subwoofer doesn't work.	The power cable is not connected properly.	Set the POWER switch to OFF, then make sure the power cable is connected properly.
There's no sound.	The VOLUME control is set to 0.	Turn up the VOLUME control.
	The subwoofer cable is not connected properly.	Make sure the subwoofer cable is connected properly.
The subwoofer is too quiet.	The source material doesn't contain much bass.	Try playing source material that contains more bass.
	Bass sounds are being cancelled out by standing waves.	Reposition the subwoofer, or break up parallel wall surfaces by placing bookshelves or other large objects along the wall.

Specifications

■ Surround speakers (NS-B285)

Type..... Full-range acoustic-suspension non-magnetic shielding type
 Driver..... 6.5 cm (2-1/2") cone speaker
 Nominal input power 30 W
 Maximum input power 80 W
 Impedance 6 Ω
 Frequency response..... 110 Hz–40 kHz
 Sensitivity 81 dB/2.83 V, 1 m
 Dimensions (W × H × D)
 90 × 90 × 109 mm (3-1/2" × 3-1/2" × 4-1/4")
 (without stand)
 90 × 120 × 123 mm (3-1/2" × 4-3/4" × 4-7/8")
 (with stand)
 Weight..... 0.45 kg (1 lbs.) (without stand)

■ Front/center speaker (NS-BR300)

Type..... Full-range acoustic-suspension non-magnetic shielding type
 Driver..... 4 × 10 cm (1-1/2 × 4 in) cone speaker × 3
 Frequency response..... 150 Hz to 20 kHz
 Impedance 6 Ω
 Dimensions (W × H × D)
 NS-BR300 800 × 50 × 70 mm (31-1/2" × 2" × 2-3/4")
 Stand..... 45 × 70 × 88 mm (1-3/4" × 2-3/4" × 3-1/2")
 Weight..... 1.5 kg (3 lbs.)

■ Subwoofer (NS-SW280)

Type Advanced Yamaha Active Servo Technology
 Driver..... 16 cm (6-1/2") cone woofer non-magnetic shielding type
 Output power..... 50 W (100 Hz, 5 Ω, 10% T.H.D.)
 Dynamic power 100 W, 5 Ω
 Input impedance..... INPUT (1P RCA pin jack): 10 kΩ
 Frequency response 30 Hz–160 Hz
 Input sensitivity..... INPUT (1P RCA pin jack): 80 mV (50 Hz, 50 W/5 Ω)
 Power supply
 U.S.A. and Canada models AC 120 V, 60 Hz
 Australia model..... AC 240 V, 50 Hz
 U.K. and Europe models AC 230 V, 50 Hz
 Dimensions (W × H × D) 262 × 264 × 316 mm
 (10-3/8" × 10-3/8" × 12-1/2")
 Weight..... 6.9 kg (15.2 lbs.)

Specifications are subject to change without notice.