



**Heavy Duty Power Equipment**

# Owner's Manual

This manual contains important safety instructions for gasoline generator models: *4550Pro, 5650, 6500, 6500EL, 7550EL Pro* that should be followed during installation and maintenance of the generator and batteries

READ SAFETY WARNINGS AND OPERATING INSTRUCTIONS CAREFULLY, SAVE THESE INSTRUCTIONS.

### Contents:

1. Tools and Accessories
2. DEK Product Lines
3. Missing Parts Request Form
4. Warnings
5. Warnings and Specifications
6. Component Identification
7. Wheel Kit Assembly & Commissioning the Battery
8. Commissioning the Battery
9. Controls
10. Operating the Generator
11. Operating the Generator
12. Maintenance
13. Maintenance
14. Transporting and Storage
15. Troubleshooting
16. Warranty and Service

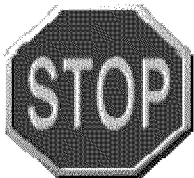
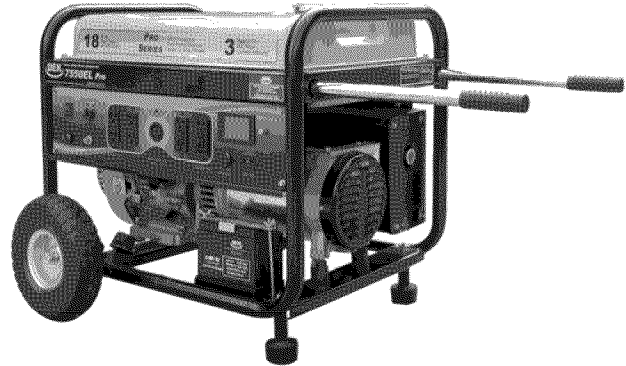

**DO NOT RETURN THIS GENERATOR  
TO THE STORE!**

**HAVE QUESTIONS OR NEED HELP?**  
call 24 hrs / 7-days a week help-line: [1] 919-550-3259  
or go to [www.DEKPowerUSA.com](http://www.DEKPowerUSA.com)

**Have the following information ready when you call us:**

Date of Purchase: \_\_\_\_\_

Location of Purchase: \_\_\_\_\_

Serial #: \_\_\_\_\_

**For your convenience, DEK offers a complete range of generator accessories. Please ask your local retailer for more details or call [1] 919-550-3221.**

**Universal Generator Cover:**

Heavy duty nylon cover fits over most models of 4000W to 7500W generators. A flexible handle bar flap accommodates most common handle bar designs. The cover keeps water, ice, snow, dust and dirt from damaging your generator when it is in storage. It can also be used as a rain cover to protect the generator when stored outdoors. The cover cannot be used while the generator is in operation. The generator should be allowed to cool down for approximately 15 minutes after being shut down, prior to placing the cover over the generator.

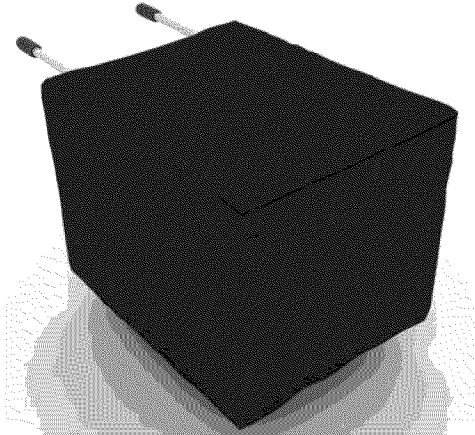

**SAE 10W30 Motor Oil:**

A premium high performance formulation designed for high RPM small gasoline engines such as those used on generators. This oil provides excellent protection against viscosity and thermal breakdown that often happens under the prolonged severe duty experienced by generator engines. Use of this oil formulation is highly encouraged by the manufacturer. Frequent oil changes with high quality motor oil will prolong the life of your DEK generator.



**Adapters:**

Converts 240V twist lock (L14-30) to six (6) 120V outlets. Lighted ends show when power is on. Ideal for use in combination with a 240V extension cord. Can handle up to 30 Amps (7200 Watts).

**Extension Cords:**

240V, 10/4, heavy duty extension cords with L14-30 connectors at each end. Lighted end shows when power is on. ***Ideal for use in combination with the 240V to 120V adapter, eliminating up to six 120V extension cords. This cord reduces harmful voltage drops experienced when using most 120V extension cords.*** Available in 25' lengths and can be combined to reach the desired length.

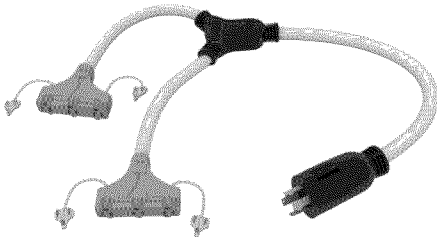

**Fuel Stabilizer:**

Use of DEK's fuel stabilizer keeps your gasoline fresh for up to 12 months. Gasoline breaks down in 60 days, potentially causing damage to your engine. DEK recommends storing your generator with the fuel tank full and with fuel stabilizer added. This protects the engine and fuel system from the effects of humidity and ensures your generator is ready for use at all times.



Other fine products offered by **DEK** Heavy Duty Power Equipment

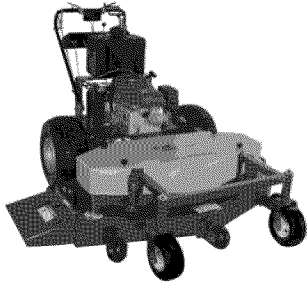

Commercial Lawn Mowers

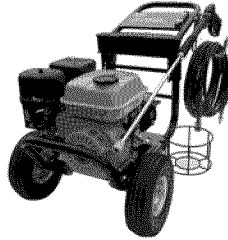

Heavy Duty Pressure Washers

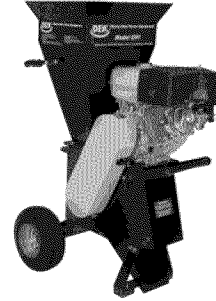

Rental Grade Chipper Shredders

**For more information or where to purchase DEK outdoor power equipment, visit us at: [www.DEKPowerUSA.com](http://www.DEKPowerUSA.com)**

### Missing Parts Request Form

Please indicate the part that you are missing:

- Hardware bag
- Wheel Kit
- Other \_\_\_\_\_

\_\_\_\_\_  
Name

\_\_\_\_\_  
Address

Date of purchase \_\_\_\_\_

\_\_\_\_\_

Model #:

- 4550Pro
- 5650
- 6500 or 6500EL
- 755EL Pro

\_\_\_\_\_  
Phone

\_\_\_\_\_  
Email

Serial #: \_\_\_\_\_

Comments:

**IMPORTANT: Please include your receipt. Without a receipt, your order will be delayed. You may also email us at: [customerservice@gxioutdoorpower.com](mailto:customerservice@gxioutdoorpower.com) or fax at 919-550-3277. If emailing, please scan in your proof of purchase.**

This owner's manual is considered a permanent part of the generator and should remain with the generator if resold. The information and specifications included in this publication were in effect at the time of approval for printing.

GXi Outdoor Power, LLC, exclusive marketer of DEK Heavy Duty Power Equipment, reserves the right to discontinue or change specifications or design at any time without notice and without incurring any obligation whatever. No part of this publication may be reproduced without written permission.

**EMISSION CONTROL SYSTEM INFORMATION**

The U.S. and California Clean Air Acts

EPA and California regulations require all manufacturers to furnish written instructions describing the operation and maintenance of emission control systems. The following instructions and procedures must be followed in order to keep the emissions from your DEK engine within the emission standards. Maintenance, replacement, or repair of the emission control devices and systems may be performed by any engine repair establishment or individual, using parts that are "certified" to EPA standards.

**SAFETY LABEL LOCATIONS**

These labels warn you of potential hazards that can cause serious injury. Read them carefully. If a label comes off or becomes hard to read, contact your DEK generator dealer for a replacement.

**SAFETY INFORMATION**

DEK generators are designed to give safe and dependable service if operated according to instructions. Read and understand this owner's manual before operating your generator.

**OPERATOR RESPONSIBILITY**

Know how to stop the generator quickly in case of emergency. Understand the use of all generator controls, output receptacles, and connections. Be sure that anyone who operates the generator receives proper instruction. Do not let children operate the generator.

 **WARNING**

**The engine exhaust from this product contains chemicals known to the State of California to cause cancer, birth defects or other reproductive harm.**

 **DANGER**

**Fire and Burn Hazards**

The exhaust system gets hot enough to ignite some materials.

- Keep the generator at least 3 feet (1 meter) away from buildings and other equipment during operation.
- Do not enclose the generator in any structure.
- Do not smoke when refueling.
- Keep flammable materials away from the generator.
- The muffler becomes very hot during operation and remains hot for a while after stopping the engine. Be careful not to touch the muffler while it is hot.
- Let the engine cool before storing the generator indoors.
- Refuel in a well ventilated area with the engine stopped.
- Fuel vapors are extremely flammable and may ignite after the engine has started. Make sure that any spilled fuel has been wiped up before starting the generator.

**Connections to a Building Electrical System**

Connections for standby power to a building electrical system must be made by a qualified electrician. The connection must isolate the generator power from utility power, and must comply with all applicable laws and electrical codes. A transfer switch, which isolates generator power from utility power, is available through any of GXi's authorized dealers of DEK generators.

 **WARNING**

**Generator must be installed by a qualified electrician and connected to transfer equipment as a separately derived system in accordance with the National Electrical Code, NFPA 70. The generator shall be connected through transfer equipment that switches all conductors other than the equipment grounding conductor. The frame of the generator shall be connected to an approved grounding electrode.**

**Improper connections to a building electrical system can allow electrical current from the generator to backfeed into the utility lines. Such backfeed may electrocute utility company workers or others who contact the lines during a power outage, and the generator may explode, burn, or cause fires when utility power is restored.**

**Ground System**

DEK portable generators have a system ground that connects generator frame components to the ground terminals in the AC output receptacles. The system ground is not connected to the AC neutral wire. If the generator is tested by a receptacle tester, it will not show the same ground circuit condition as for a home receptacle where the ground and neutral are connected.

**Special Requirements**

There may be Federal or State Occupational Safety and Health Administration (OSHA) regulations, local codes, or ordinances that apply to the intended use of the generator. Please consult a qualified electrician, electrical inspector, or the local agency having jurisdiction.

 **DANGER**

**CARBON MONOXIDE GAS**

**Exhaust contains poisonous carbon monoxide, a colorless and odorless gas. Breathing exhaust can cause loss of consciousness and may lead to death. To keep exhaust gas from accumulating, use in an area with adequate ventilation. DO NOT use this generator in a garage, basement, crawlspace, enclosed shed, or any other area that does not have adequate ventilation. DO NOT use this generator near ventilation ducts or open windows that may allow exhaust gasses to enter your home or business. ONLY operate this generator outdoors.**

 **DANGER**

**Electrocution Hazard**

- **Keep the generator dry.**
- **DO NOT use the generator in wet conditions, rain or snow, or near a pool or sprinkler system**
- **DO NOT use when your hands are wet**

**NEVER START OR STOP THE ENGINE WITH DEVICES CONNECTED TO THE GENERATOR.**

**AC Applications**

Before connecting an appliance or power cord to the generator:

1. Make sure that appliances are in good working order. Faulty appliances or power cords can create a potential for electrical shock. If an appliance begins to operate abnormally, becomes sluggish or stops suddenly, turn it off immediately.
2. Disconnect the appliance, and determine whether the problem is the appliance, or if the rated load capacity of the generator has been exceeded.
3. Make sure that the electrical rating of the tool or appliance does not exceed that of the generator. Never exceed the maximum power rating of the generator. Power levels between rated and maximum may be used for no more than 30 minutes.

**Substantial overloading will open the circuit breaker. Exceeding the time limit for maximum power operation or slightly overloading the generator may not switch the circuit breaker or circuit protector OFF, but will shorten the service life of the generator.**

Limit operation requiring maximum power to 30 minutes. For continuous operation (longer than 30 minutes), do not exceed 80% of the rated power balanced equally on the A&B sides of the Alternator.

The total power requirements (VA) of all appliances connected must be considered. Appliance and power tool manufacturers usually list rating information near the model number or serial number.

 **WARNING**

**Failure to properly follow maintenance instructions and precautions can cause serious injuries or death. Always follow the inspection and maintenance recommendations and schedules in this owner's manual.**

**Safety Precautions:**

Make sure the engine is off before you begin any maintenance or repairs. This will eliminate several potential hazards:

- **Carbon monoxide poisoning from engine exhaust.**  
Be sure there is adequate ventilation whenever you operate the engine.
- **Burns from hot parts.**  
Let the engine and exhaust system cool before touching.
- **Injury from moving parts.**  
Do not run the engine unless instructed to do so.

In the State of California a spark arrestor is required by law. Other states may have similar laws. Federal laws apply on all federal lands. If you equip the muffler with a spark arrestor, it must be maintained in effective working order. See page 11.

**Rapid retraction of the recoil starter cord can pull the starter cord back faster than you can let go. When starting the engine, pull the cord slowly until resistance is felt then pull rapidly to avoid kickback.**

 **DANGER**

**Changing the speed of the generator by adjusting the governor can cause damage to the generator, devices attached to the generator, and may result in bodily injury. Do not adjust or tamper with the engine speed setting.**

**Product Specifications**

Generator	4550 Pro	5650	6500, 6500EL	7550EL Pro
Rated frequency	60 Hz	60 Hz	60 Hz	60 Hz
Rated voltage	120V / 240V / 12V	120V / 240V / 12V	120V / 240V / 12V	120V / 240V / 12V
Rated output power	4.55 kW (Max.)	5.65 kW (Max.)	6.5 kW (Max.)	7.55 kW (Max)
AC output (Max.)	18.95A	23.5A	27.1A	31.5A
DC output	12V, 8.3A	12V, 8.3A	12V, 8.3A	12V, 8.3A
Engine type	OHV 4-Stroke	OHV 4-Stroke	OHV 4-Stroke	OHV 4-Stroke
displacement	270 cc	401 cc	401 cc	401 cc
Compression ratio	8.2:1	8.0:1	8.0:1	8.0:1
Rated rotation speed	3600 RPM	3600 RPM	3600 RPM	3600 RPM
Rated power	10 Hp	11 Hp	13 Hp	14 Hp
Starting system	Recoil	Recoil	Recoil and optional electric starter (EL)	Recoil and electric starter
Rotation direction	Counter clockwise	Counter clockwise	Counter clockwise	Counter clockwise
Fuel type	Unleaded gasoline	Unleaded gasoline	Unleaded gasoline	Unleaded gasoline
Low oil alert	Yes	Yes	Yes	Yes
Fuel tank size	12.6 gallons	5.94 gallons	5.94 gallons	12.6 gallons
Integrated voltmeter	Yes	Yes	Yes	Yes

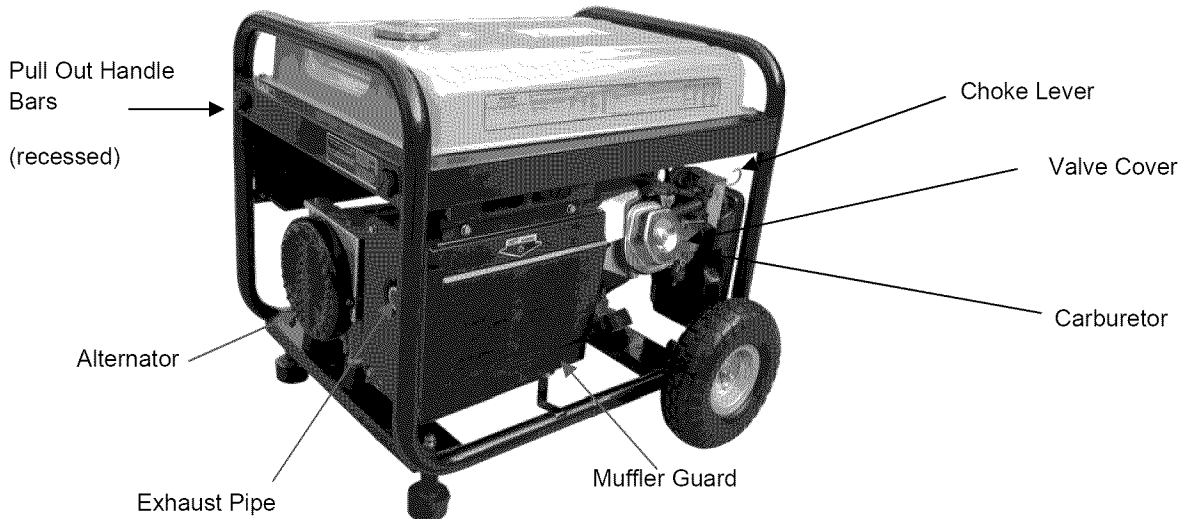
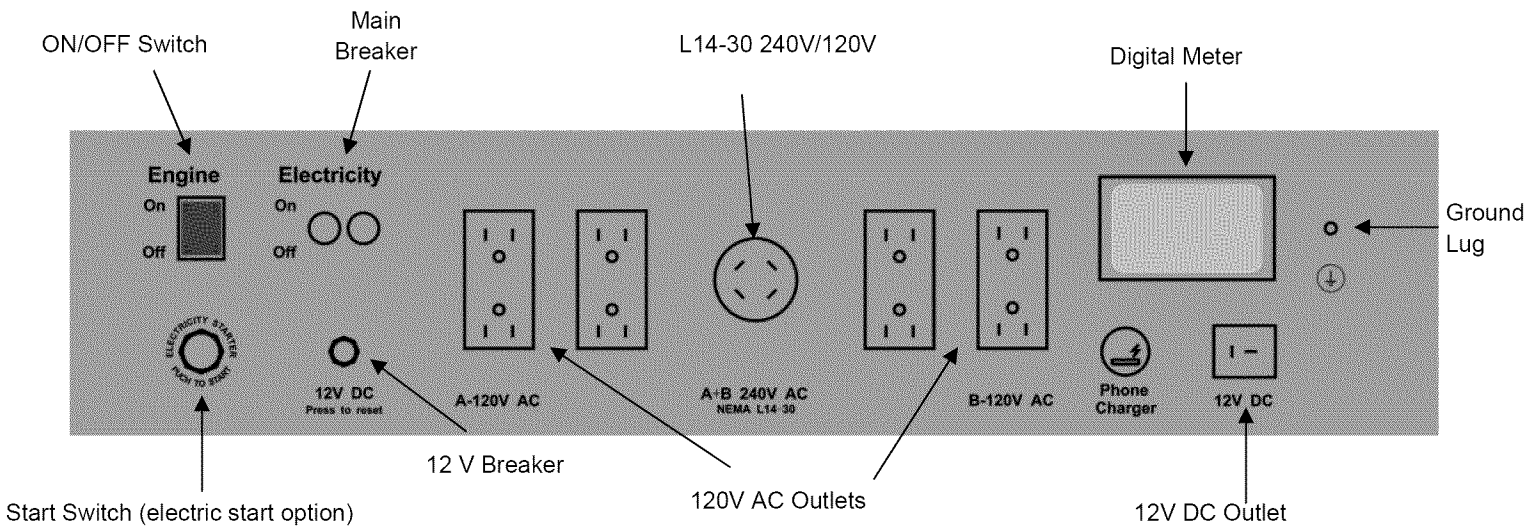
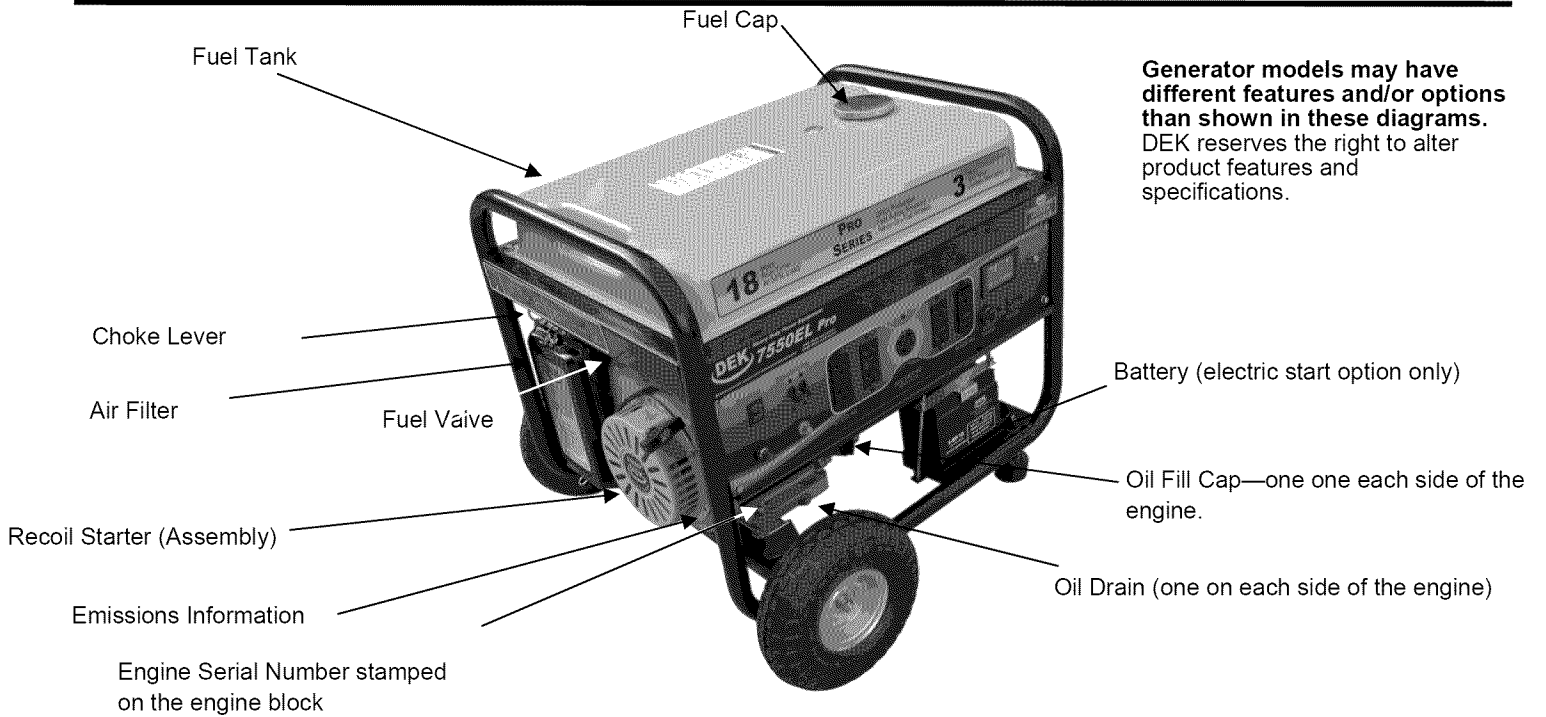

**Required Tools (not supplied)**

1. Adjustable wrench or a socket wrench with a 8 mm socket.

**Approximate assembly time is 5 minutes.**

**Supplied with your generator:**

1. Two(2) foot assemblies with two (2) 8 mm nuts.
2. Two (2) wheel axle assemblies.

Two pre-assembled, retractable, handle bars, one on each side of the generator frame. Twist to lock / unlock. Pull or push to extend / retract.

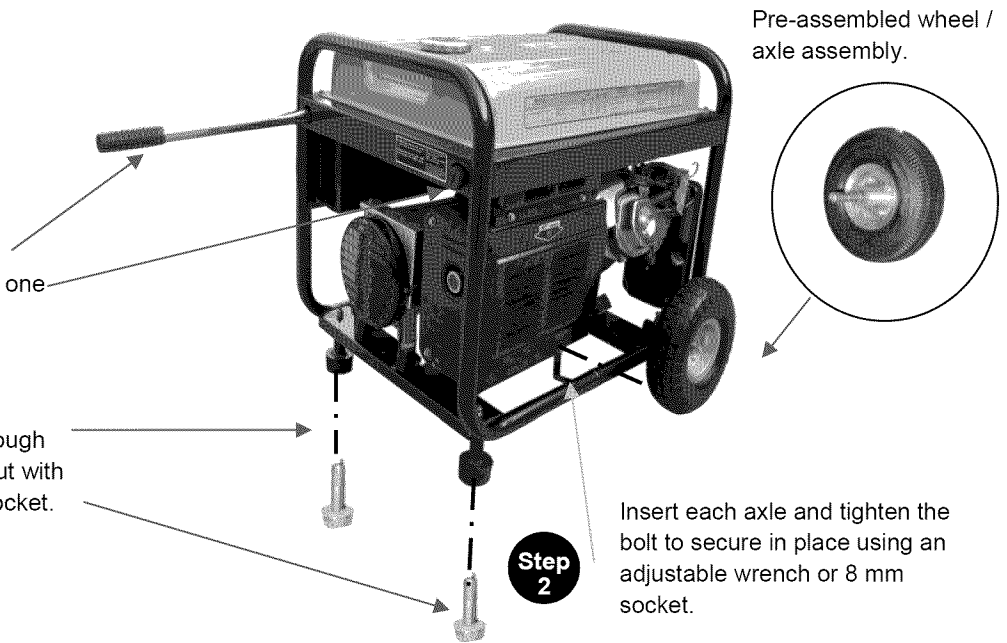

**Step 1**

Insert each foot assembly through holes in the frame. Tighten nut with adjustable wrench or 8 mm socket.

**Step 2**

Insert each axle and tighten the bolt to secure in place using an adjustable wrench or 8 mm socket.

**Additional equipment required to safely operate this generator:**

1. Gas can.
2. Unleaded gasoline.
3. SAE 10W30 & 14HP oil (a little more than 1 quart for DEK 11hp, 13hp and 14hp engines, a little less than 1 quart is required for DEK's smaller engines).
4. An oil fill funnel.
5. Gasoline fuel stabilizer (for storing your generator). 120V and/or 240V extension cords.
6. An adjustable wrench or a 12mm socket for oil changes.

**Note:** A spark arrestor was supplied with your generator and must be installed for use within the State of California. See supplemental instructions.

**Commissioning the Battery**

The battery is an optional feature. The battery is used to start a generator equipped with an electric starter. Not all generators are sold with batteries. Please verify with your retailer if you believe the battery is missing.



**WARNING**

Lead acid storage batteries contain sulfuric acid which can cause serious injuries. The battery also gives off explosive gases. Keep sparks, flames and cigarettes away. Provide adequate ventilation when charging or using batteries. Battery posts, terminals and related accessories contain lead and lead compounds. Avoid spills of electrolyte and wash hands thoroughly after handling.

Use gloves and safety glasses when handling and installing lead acid batteries.

If you get electrolyte in your eyes, flush your eyes with clean water for 15 minutes and seek medical attention. Keep out of reach of children.

**Battery Maintenance:**

Routine maintenance is essential to keep the battery in good condition and maximize its service life.

1. Keep the terminals and connections free from corrosion and coat with petroleum jelly or grease to reduce corrosion from occurring.
2. If the generator sits idle for more than two (2) months, it is best to recharge the battery to ensure it is fully charged when you need it and to increase battery life.

**FOR YOUR SAFETY AND CONVENIENCE, THE BATTERY WAS SHIPPED SEALED AND PRE-CHARGED.**

**The battery is ready to be connected to the generator.**

**To connect the battery, use an adjustable wrench or 8 mm socket to secure the black wire to the positive terminal and the negative terminal.**

**DC Terminals**

Some generators are shipped with optional DC battery charging cables, have a standard 12V DC receptacle, and have a 12V cigarette lighter style outlet.

The battery must be connected to the generator DC terminals with the proper polarity (battery positive to generator red terminal and battery negative to the generator black terminal).

**WARNING**

**Do not use the 12V DC and the AC receptacles at the same time.**

**Connecting the battery cables:**

1. Before connecting the battery charging cables to a battery that is installed in a vehicle, disconnect the vehicle ground battery cable from the battery negative ( - ) terminal.
2. Connect the other end of the positive ( + ) battery cable to the generator positive ( + ) terminal.
3. Connect the positive ( + ) battery cable to the battery positive ( + ) terminal.
4. Connect the negative ( - ) battery cable to the battery negative ( - ) terminal.
5. Connect the other end of the negative ( - ) battery cable to the generator negative ( - ) terminal.
6. Start the generator.

**CAUTION: Do not start the vehicle while the battery charging cable is connected and the generator is running. The vehicle or the generator may be damaged.**

**Disconnecting the battery cables:**

1. Stop the engine.
2. Disconnect the negative ( - ) battery cable from the generator negative ( - ) terminal.
3. Disconnect the other end of the negative ( - ) battery cable from the battery negative ( - ) terminal.
4. Disconnect the positive ( + ) battery cable from the generator positive ( + ) terminal.
5. Disconnect the other end of the positive ( + ) battery cable from the battery positive ( + ) terminal.
6. Reconnect the vehicle ground battery cable to the battery negative ( - ) terminal.



**WARNING**

The engine was shipped without engine oil. **DO NOT START THE ENGINE WITHOUT FILLING THE ENGINE WITH OIL.** Use SAE 10W-30 for normal conditions and SAE 5W-30 when the ambient temperature is below 32° F.

**Choke Rod**

The choke is used to provide an enriched fuel mixture when starting a cold engine. It can be opened and closed by operating the choke rod manually. Pull the rod out toward CLOSED to enrich the mixture for cold starting. Open once the engine is running.

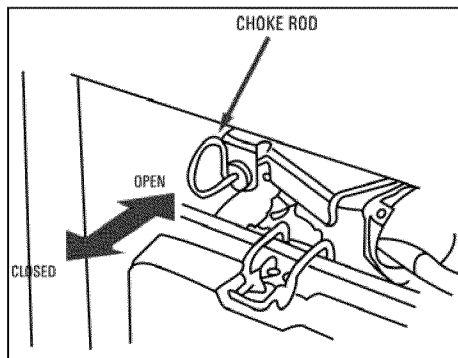

**Fuel Valve Lever**

The fuel valve is located between the fuel tank and carburetor. When the valve lever is in the ON position, fuel is allowed to flow from the fuel tank to the carburetor. Be sure to return the fuel valve lever to the OFF position after stopping the engine.

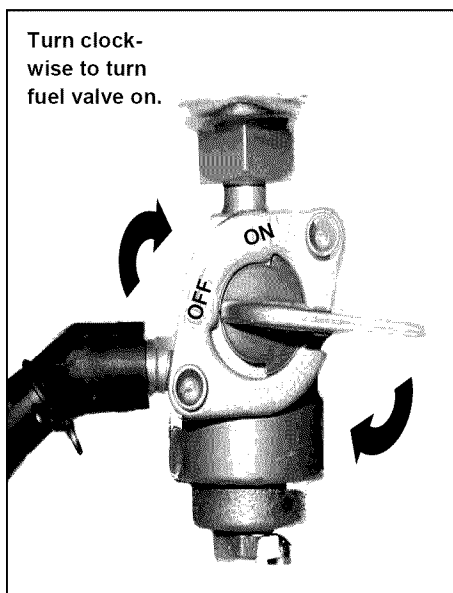

**Engine Switch**

To start and stop the engine.

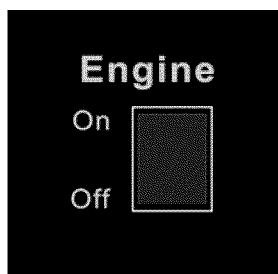

Engine ON / OFF Switch

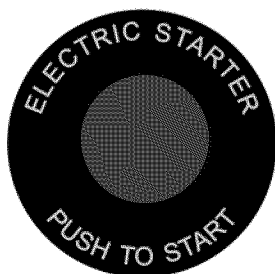

Electric Starter Switch (optional feature)

**Recoil Starter**

To start the engine, pull the starter grip lightly until resistance is felt, then pull briskly.

**NOTICE:**  
Do not allow the starter grip to snap back against the engine. Return it gently to prevent damage to the starter.

The recoil starter is used to start the engine if the generator is not equipped with a 12 volt battery to operate the starter motor, or if the battery does not contain adequate charge to operate the starter motor.

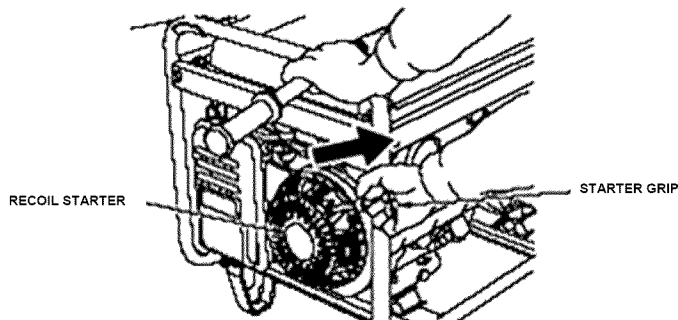

**Oil Alert System**

The Oil Alert system is designed to prevent engine damage caused by an insufficient amount of oil in the crankcase. Before the oil level in the crankcase can fall below a safe limit, the Oil Alert system will automatically stop the engine (the engine switch will remain in the ON position). The Oil Alert system should not take the place of checking the oil level before each use. If the engine stops and will not restart, check the engine oil level (see page 14) before troubleshooting in other areas.

**Ground Terminal**

The generator ground terminal is connected to the frame of the generator, the metal non-current-carrying parts of the generator, and the ground terminals of each receptacle.



**WARNING**

Before using the ground terminal, consult a qualified electrician, electrical inspector or local agency having jurisdiction for local codes or ordinances that apply to the intended use of the generator.

**NOTE: SYSTEM GROUND IS NOT CONNECTED TO THE AC NEUTRAL ON THIS GENERATOR. CONSULT AN ELECTRICIAN WHEN CONNECTING THIS GENERATOR TO YOUR HOME OR BUSINESS ELECTRICAL PANEL TO ENSURE GROUNDING MEETS THE LOCAL ELECTRICAL CODE**

**⚠ DANGER**

**CARBON MONOXIDE GAS**

**CARBON MONOXIDE** Using a generator indoors **CAN KILL YOU IN MINUTES.**

Generator exhaust contains carbon monoxide (CO). This is a poison you cannot see or smell. If you can smell the generator exhaust, you are breathing CO. But even if you cannot smell the exhaust, you could be breathing CO.

**NEVER** use a generator inside homes, garages, crawl-spaces, or other partly enclosed areas. Deadly levels of carbon monoxide can build up in these areas. Using a fan or opening windows and doors does **NOT** supply enough fresh air.

**ONLY** use a generator outside and far away from windows, doors, and vents. These openings can pull in generator exhaust.

Even when you use a generator correctly, CO may leak into the home. **ALWAYS** use a battery-powered or battery-backup CO alarm in the home.

If you start to feel sick, dizzy, or weak after the generator has been running, move to fresh air **RIGHT AWAY**. See a doctor. You could have carbon monoxide poison.”

**⚠ WARNING**

For power outages, permanently installed stationary generators are better suited for providing backup power to the home. Even a properly connected portable generator can become overloaded. This may result in overheating or stressing the generator components, possibly leading to a generator failure.

**Step 1.**

Ensure all electrical loads are removed from the generator. Disconnect all the extension cords and ensure the main breaker is in the OFF position. Remove all flammable materials and debris from the area. Make sure the generator is level.

**Step 2.**

Check the oil level by removing the oil fill cap.

- Put the generator on a level surface with the engine stopped.
- Remove the oil filler cap.
- Check the oil level. If the oil level is low, fill it until the oil is overflowing. It will take approximately 1.1 - 1.5 quarts of oil.

If additional oil is need, SAE 10W-30 engine oil is recommended for most general purpose applications. In cold weather climate, use SAE 5W-30.

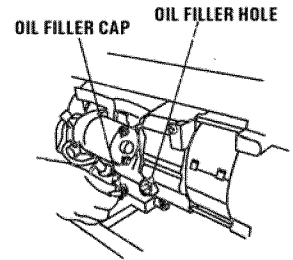
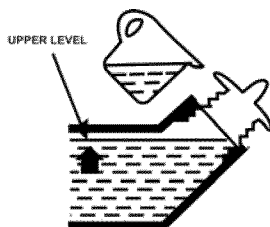

**Step 3.**

Make sure there is fuel in the gasoline tank. Look at the fuel level indicated by removing the fuel cap to inspect the contents of the fuel tank. The fuel filter can also be inspected once the fuel cap is removed. Ensure the fuel filter is clean of dirt and debris. Tightly secure the fuel cap after your inspection is complete.

**Fuel can damage paint and plastic.** Be careful not to spill fuel when filling your fuel tank. Damage caused by spilling fuel is not covered under warranty. Use unleaded gasoline with a pump octane rating of 86 or higher. This engine is certified to operate on unleaded gasoline. Unleaded gasoline produces fewer engine and spark plug deposits and extends exhaust system life. Never use stale or contaminated gasoline or an oil/gasoline mixture. Avoid getting dirt or water in the fuel tank.

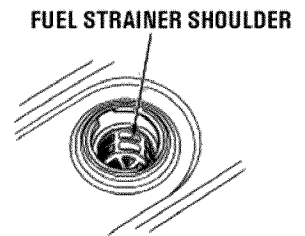

**⚠ WARNING**

**Ethanol warning**  
**This portable generator is not for use with gasoline/ethanol blends with over 15% ethanol.**

**DO NOT overfill the tank. Leave a 1 inch air gap in the tank. Gasoline is highly flammable and explosive. You can be burned or seriously injured when refueling.**

- **Stop engine and keep heat, sparks, and flame away.**
- **Refuel only outdoors.**
- **Wipe up spills immediately.**

**Step 4.**

Set the fuel valve lever to the ON position by rotating it clockwise.

**Step 5.**

Pull the choke lever to the CLOSED position. See page 7 for a diagram of the choke lever.

**Step 6.**

Turn the generator ON/OFF switch to the "ON" position.

**Step 7.**

Start the engine

1. If you have an electric starter, press the electric starter switch to the START position, hold it there for 5 seconds and let it come to rest in the ON position once the engine has started.
2. If you are using the recoil starter, pull slightly on the cord until you feel some pressure. Once you feel the back-pressure building, rapidly pull the cord.

**Step 8.**

Once the generator is running, push the choke lever into the OPEN position.

**Step 9.**

Let the generator warm up for approximately 3 minutes before applying any electrical loads.

**Step 10.**

Apply loads to the generator one at a time, allowing the generator to stabilize after you add each incremental load. Add the loads with the largest surge power requirement first. This would include refrigerators, air-conditioners, large motors, and pumps. Add smaller loads once the generator has stabilized with the larger loads.

**ALWAYS UNPLUG APPLIANCES AND REMOVE ALL ELECTRICAL LOADS BEFORE REFUELING. THEN FOLLOW STEPS 2 - 10.**



Connecting a load larger than this generator's power rating may damage the circuit breakers, alternator and sensitive appliances.

Continuously loading this generator above 80% of its maximum output power will shorten the life of the generator.

Balance the load evenly between the A and B outlets to maximize the output power.

Appliances with electric motors require an **additional 150% power when they are starting up** (indicated by an \* and in bold in the chart below).

**To determine maximum load that you may safely connect to this generator:**

1. Calculate the maximum continuous power required by adding up the running power of each appliance. The total running power of your appliances cannot exceed the maximum output power of this generator.
2. Calculate the surge power by:
  - i) Adding up the running power of each appliance with an \* and in **bold** below.
  - ii) Multiplying the total by 1.5.
  - iii) Adding this to the total running power calculated in step 1 above.

The surge power requirements of your appliances cannot exceed the surge power rating of this generator.

**Typical Residential Loads**

<b>Appliance</b>	<b>Running Power</b>
Light bulbs (each)	75 Watts
Stove element (each)	1000 Watts
Microwave	1500 Watts
Coffee maker	700 Watts
Television	750 Watts
VCR	250 Watts
Computer & monitor	800 Watts
Space heater	1500 Watts
Washing machine	1000 Watts
NG clothes dryer	750 Watts
Electric clothes dryer	5500 Watts
Dishwasher	1850 Watts
Water heater	5000 Watts
Electric furnace	5000 Watts
Toaster	1200 Watts
<b>Box fan*</b>	<b>750 Watts</b>
<b>Window A/C - 8000 BTU*</b>	<b>2400 Watts</b>
<b>Central A/C (per ton)*</b>	<b>2800 Watts</b>
<b>Furnace blower*</b>	<b>850 Watts</b>
<b>2 hp well pump*</b>	<b>2000 Watts</b>
<b>Refrigerator*</b>	<b>1000 Watts</b>
<b>Freezer*</b>	<b>1000 Watts</b>

**STOPPING THE GENERATOR**

**In an emergency:**

To stop the engine in an emergency, move the engine switch to the OFF position and turn the fuel valve OFF.

**In normal use:**

1. Turn the AC circuit breaker to the OFF position (if applicable).
2. Disconnect all loads and extension cords.
3. Allow the engine to run with no load for 3 minutes.
4. Turn the engine switch to the OFF position.
5. Turn the fuel valve lever to the OFF position.
6. Allow the generator to cool off before touching any engine or alternator components. It may take as long as 30 minutes before the generator is cool enough to touch safely.

**MAINTENANCE**

**The Importance of Maintenance**

Good maintenance is essential for safe, economical, and trouble-free operation. It will also help reduce air pollution.

To help you properly care for your generator, the following pages include a maintenance schedule, routine inspection procedures, and simple maintenance procedures using basic hand tools. Other service tasks that are more difficult, or require special tools, are best handled by professionals and are normally performed by a DEK technician or other qualified mechanic.

The maintenance schedule applies to normal operating conditions. If you operate your generator under severe conditions, such as sustained high-load or high-temperature operation, or use it in unusually wet or dusty conditions, consult your servicing dealer for recommendations applicable to your individual needs and use.

**Maintenance, replacement, or repair of the emission control devices and systems may be performed by any engine repair establishment or individual, using parts that are "certified" to EPA standards.**

**Maintenance Schedule**

Item	Before each use	20hrs or every 3 month	50 hrs or every 3 months	100 hrs or every 6 months	300 hrs or every 1 year
Engine oil (Check)	X				
Engine Oil (Change)		X			
Air Cleaner (Check)	X				
Air Cleaner Wash			X		
Fuel filter Cup (Clean)				X	
Spark Plug (Clean)				X	
Spark Plug (Change)					X
Optional Spark Arrestor (Clean)			X		
Valve Clearance (Adjust)					X*
Fuel Tank and Filter (Clean)				X*	
Fuel Tube (Check)	Every 2 yrs (replace if necessary)*				
Combustion Chamber (Clean)	After every 250 hrs*				

\* Should be performed by an authorized DEK dealer.

**Replacement Parts**

The emission control systems on your DEK engine were designed, built, and certified to conform with EPA and California emission regulations. We recommend the use of genuine DEK parts whenever you have maintenance done. These original-design replacement parts are manufactured to the same standards as the original parts, so you can be confident of their performance. The use of replacement parts that are not of the original design and quality may impair the effectiveness of your emission control system.

A manufacturer of an aftermarket part assumes the responsibility that the part will not adversely affect emission performance. The manufacturer or rebuilder of the part must certify that use of the part will not result in a failure of the engine to comply with emission regulations.

**Engine Oil Change**

Drain the oil while the engine is warm to assure rapid and complete draining.

1. Remove the drain plug and sealing washer, remove the oil filler cap, and drain the oil.
2. Reinstall the drain plug and sealing washer. Tighten the plug securely.
3. Refill with the recommended oil (SAE 10W-30 ) and check the oil level.

Dispose of used motor oil in a manner that is compatible with the environment. Do not throw it in the trash, pour it on the ground, or down a drain.

**Air Cleaner Service**

A dirty air cleaner will restrict air flow to the carburetor. To prevent carburetor malfunction, service the air cleaner regularly. Service more frequently when operating the generator in extremely dusty areas.

**NOTICE:**

Never run the generator without the air filter. Rapid engine wear will result.

1. Unsnap the air cleaner cover clips, remove the air cleaner cover, and remove the element.
2. Wash the air cleaner element in a solution of household detergent and warm water, then rinse thoroughly, or wash in nonflammable or high flashpoint solvent. Allow the air cleaner element to dry thoroughly.
3. Soak the air cleaner element in clean engine oil and squeeze out the excess oil. The engine will smoke during initial startup if too much oil is left in the air cleaner element.
4. Reinstall the air cleaner element and the cover.

**Fuel Filter Cleaning**

The fuel filter cup / screen prevents dirt which may be in the fuel from entering the carburetor. The fuel filter should be inspected and cleaned on a regular basis. For best results, clean the filter with gasoline and a toothbrush or blow the debris out of the filter with air pressure.

**Spark Plug Service**

In order to service the spark plug, you will need a spark plug wrench. Recommended spark plugs: BPR5ES (NGK) and W16EPR-U (DENSO). To ensure proper engine operation, the spark plug must be properly gapped and free of deposits.

**If the engine has been running, the muffler will be very hot. Be careful not to touch the muffler.**

1. Remove the spark plug cap.
2. Clean any dirt from around the spark plug base.
3. Use a spark plug wrench to remove the spark plug.

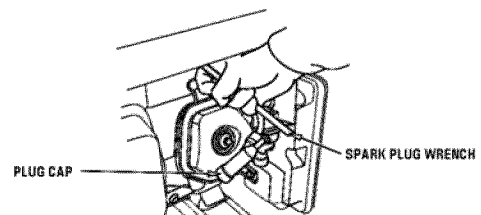

4. Visually inspect the spark plug. Discard it if the insulator is cracked, chipped or fouled.
5. Measure the plug gap with a feeler gauge. Correct as necessary by carefully bending the side electrode. The gap should be: 0.028 0.031 in (0.70 0.80 mm)

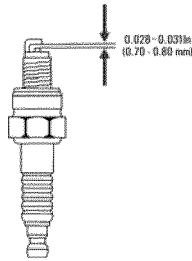

6. Check that the spark plug washer is in good condition, and thread the spark plug in by hand to prevent cross-threading.
7. After the spark plug is seated, tighten with a spark plug wrench to compress the washer.

If installing a new spark plug, tighten 1/2 turn after the spark plug seats to compress the washer. If reinstalling a used spark plug, tighten 1/8 1/4 turn after the spark plug seats to compress the washer.

**NOTICE:**

The spark plug must be securely tightened. An improperly tightened spark plug can become very hot and could damage the engine. Use only the recommended spark plugs or equivalent.

**Optional Spark Arrestor Maintenance**

If the generator has been running, the muffler will be very hot. Allow it to cool before proceeding. **The spark arrester must be serviced every 50 hours to keep it functioning as designed.**

Clean the spark arrester as follows:

1. Loosen the screw by the exhaust port of the muffler and remove the spark arrester.
2. Use a brush to remove carbon deposits from the spark arrester screen. Inspect the screen for breaks or tears and replace it if necessary.
3. Install the spark arrester in the reverse order of removal.

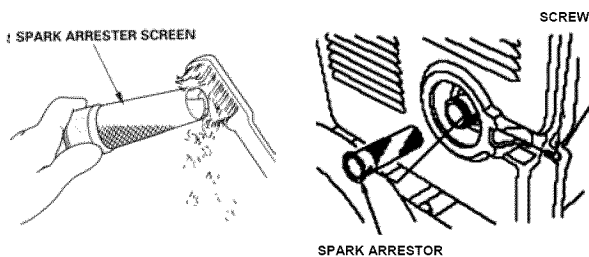

**Optional Starter Motor Fuse Replacement**

If the fuse is blown, the starter motor won't operate. Turn the engine switch to the OFF position. Remove the fuse holder cover and replace the fuse. The specified fuse is 10A.

**NOTICE:**

Never use a fuse with a different rating from that specified. Serious damage to the electrical system or fire may result.

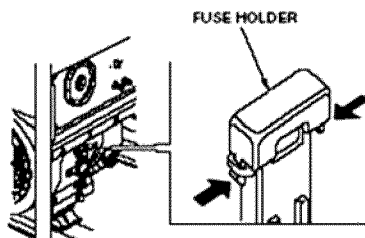

**TRANSPORTING**

When transporting the generator, turn the engine switch and the fuel valve OFF. Keep the generator level to prevent fuel spillage. Fuel vapor or spilled fuel may ignite.

Take care not to drop or strike the generator when transporting. Do not place heavy objects on the generator. When transporting the generator by loading it on to a vehicle, secure to the generator frame as shown.



**Contact with a hot engine or exhaust system can cause serious burns or fires. Let the engine cool before transporting or storing the generator.**

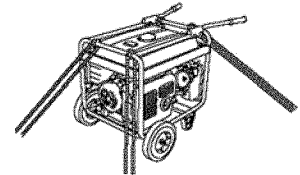

**STORING**

Before storing the unit for an extended period:

1. Be sure the storage area is free of excessive humidity and dust.
2. Service according to the table below:

STORAGE TIME	Recommended Service Procedure to prevent hard starting:
1 to 2 months	Fill with fresh gasoline and add gasoline conditioner*.
2 months to 1 year	Fill with fresh gasoline and add gasoline conditioner*.
1 year or longer	Fill with fresh gasoline and add gasoline conditioner*. Drain the carburetor float bowl. Remove the spark plug. Put a tablespoon of engine oil into the cylinder. Turn the engine slowly with the recoil starter to distribute the oil. Reinstall the spark plug. Change the engine oil. After removal from storage, drain the stored gasoline into a suitable con-
* Use gasoline conditioners that are formulated to extend storage life. Contact your authorized DEK generator dealer for conditioner recommendations.	

**Storage Preparation**

1. Drain the carburetor by loosening the drain screw. Drain the gasoline into a suitable container. Place 4 ounces of fuel stabilizer in the fuel tank.
2. Change the engine oil (page 10).
3. Remove the spark plug, and pour about a tablespoon of clean engine oil into the cylinder. Turn the engine several revolutions slowly with the recoil starter to distribute the oil, then reinstall the spark plug.
4. Slowly pull the starter grip until resistance is felt. At this point, the piston is coming up on its compression stroke and both the intake and exhaust valves are closed. Storing the engine in this position will help to protect it from internal corrosion.



**Gasoline is extremely flammable and is explosive under certain conditions. Perform this task in a well-ventilated area with the engine stopped. Do not smoke or allow flames or sparks in the area during this procedure.**

**Symptom:** No spark, engine not catching, engine won't start

Potential Causes	Check / solution	Recommendation
Fuel valve off/out of fuel	Fill tank/turn fuel valve on	
Spark arrestor clogged	Remove, clean and replace.	
Choke is open	Close choke by pulling choke wire out. Open choke after starting	
Vacuum check valve has failed	Replace check valve	Call DEK for parts/service
On/Off switch broken	Use fuel shut-off as ON/OFF switch until switch is replaced.	Call DEK for parts/service
Oil level too low	The engine shuts down when oil level low	
Oil switch	Verify oil switch/sensor is functioning . The oil switch is the gold, brass colored box about 3 inches to the left of the oil fill cap. Dis-connect oil switch by disconnecting black lead out of finger connection. If the engine starts, then switch/sensor is faulty or the oil level is too low, if engine still does not start, then switch/sensor is probably ok to reassemble	Call DEK for parts/service
Recoil is broken	If ratchets are broken they will not spin the engine.	Call DEK for parts/service
Fuel filter is dirty	Contaminates will clog filter, not allowing fuel to get to engine. Clean or replace fuel filter.	
Fuel is contaminated	Contaminates in fuel will not allow combustion at the specified pressure and temperate and blocks filters	
Spark plug boot off/loose	Press spark plug boot firmly on spark plug.	Call DEK for parts/service
Ignition coil failure		Call DEK for parts/service
Spark plug fouled or failed	Remove spark plug, clean or replace	Call DEK for parts/service
Carburator clogged	Clean with fresh fuel	Call DEK for parts/service

**Symptom:** Recoil is hard to pull or not retracting

Potential Causes	Check / solution	Recommendation
Spark arrestor	Remove, clean and replace.	
Recoil rubbing on dented housing		Call DEK for parts/service
Alternator bearing failed	Alternator bearing needs to be replaced. Send to service.	Call DEK for parts/service
Camshaft detent has failed		Call DEK for parts/service
Head valve timing is off		Call DEK for parts/service

**Symptom:** Engine starts, but then shuts off before 10 seconds

Potential Causes	Check / solution	Recommendation
Remove/Clean spark arrestor	Remove, clean and replace.	
Oil level too low	The engine shuts down when the oil level is low. Check the owners manual for oil capacity	
Fuel valve off/out of fuel	Fill tank/turn fuel valve on	
Spark plug fouled or failed	Remove spark plug, clean or replace	Call DEK for parts/service
Vacuum check valve has failed	Replace check valve, call DEK for replacement procedure.	Call DEK for parts/service

**Symptom:** Choke wire broke

Potential Causes	Check / solution	Recommendation
Choke broke	Choke should be closed while starting. Pull black choke counter-clockwise and hold in place with wire. Release after starting.	Call DEK for parts/service

**Symptom:** Engine runs: rough/vibrating/oscillating

Potential Causes	Check / solution	Recommendation
Remove/Clean spark arrestor	Remove, clean and replace.	
The choke is not open	Push choke lever in.	
Over loading generator	Disconnect some appliances	
Air filter is dirty	Clean air filter	
Fuel filter is clogged	Contaminates will clog filter, not allowing fuel to get to engine. Clean filter	
Fuel is contaminated	Contaminates in fuel will not allow combustion at the specified pressure and temperate	
Vacuum check valve has failed	Replace check valve.	Call DEK for parts/service
Head valve timing is off	Send to service	Call DEK for parts/service

**Symptom:** Engine runs, but boggs down under load

Potential Causes	Check / solution	Recommendation
Remove/Clean spark arrestor	Remove, clean and replace.	
Choke is open	Push choke lever in	
Over loading generator	Disconnect some appliances / devices	
Air filter is dirty	Clean air filter	
Fuel filter is clogged	Contaminates will clog filter, not allowing fuel to get to engine	

**Symptom:** Engine runs, Volt meter shows 120 VAC, but no power to outlets

Potential Causes	Check / solution	Recommendation
Bad extension cord/power strip	Try different / shorter extension cord or a different power strip	
Push button breaker tripped	Disconnect all loads and push reset button.	
GFCI tripped	Disconnect all loads. Push the red reset button very deep/firmly	
GFCI failed	Replace GFCI with any GFCI or household outlet	Call DEK for parts/service

<b>Symptom:</b> Engine runs and volt meter shows 240VAC and 120VAC, but no power goes to connected devices		
<b>Potential Causes</b>	<b>Check / solution</b>	<b>Recommendation</b>
Bad extension cord/power strip	Try different / shorter extension cord or a different power strip	
Device failed	Try a different light bulb or device	
Push button breaker tripped	Push button breaker tripped	
GFCI tripped	Push the red reset button very deep/firmly	
GFCI failed	Replace GFCI with any GFCI or household outlet	Call DEK for parts/service
Broken wire		Call DEK for parts/service
Toggle switch failed		Call DEK for parts/service

<b>Symptom:</b> Engine runs, volt meter shows 120VAC in 120V mode, but 120VAC or 0VAC in 240V mode		
<b>Potential Causes</b>	<b>Check / solution</b>	<b>Recommendation</b>
Circuit breaker failed		Call DEK for parts/service
Toggle switch failed		Call DEK for parts/service
Alternator phase has failed		Call DEK for parts/service
Broken wire		Call DEK for parts/service

<b>Symptom:</b> Voltage too high/low		
<b>Potential Causes</b>	<b>Check / solution</b>	<b>Recommendation</b>
Spark arrestor	Remove, clean and replace.	
Voltage not measured correctly	Voltage must be measured between hot and neutral, not hot and ground, the ground is isolated	
Speed screw bent		Call DEK for parts/service

<b>Symptom:</b> Voltage is 120 VAC on 1 phase but too high/low on other phase		
<b>Potential Causes</b>	<b>Check / solution</b>	<b>Recommendation</b>
Alternator phase has failed		Call DEK for parts/service

<b>Symptom:</b> Engine oil leaking		
<b>Potential Causes</b>	<b>Check / solution</b>	<b>Recommendation</b>
Oil leaking from crankcase gas-ket	Tighten crankcase bolts	
Oil leaking from shaft	Oil seals failed	Call DEK for parts/service

<b>Symptom:</b> Oil leaking from Valve head cover		
<b>Potential Causes</b>	<b>Check / solution</b>	<b>Recommendation</b>
Bolt not tight	Tighten bolts	

<b>Symptom:</b> Fuel leak at tank shut-off		
<b>Potential Causes</b>	<b>Check / solution</b>	<b>Recommendation</b>
Shut-off valve loose	Tighten nut on shut-off valve/replace shut-off valve	Call DEK for parts/service

<b>Symptom:</b> Fuel leaking out of carburator		
<b>Potential Causes</b>	<b>Check / solution</b>	<b>Recommendation</b>
Fuel drain screw loose	Tighten fuel drain screw	
Carburator float seat not seating	Flush with clean fuel	

<b>Symptom:</b> Cannot turn engine with recoil		
<b>Potential Causes</b>	<b>Check / solution</b>	<b>Recommendation</b>
Recoil ratchets have broken		Call DEK for parts/service
Recoil is crushed in		Call DEK for parts/service
Alternator bearing has failed		Call DEK for parts/service
Head valve timing is off		Call DEK for parts/service

<b>Symptom:</b> Fuel gauge leaks		
<b>Potential Causes</b>	<b>Check / solution</b>	<b>Recommendation</b>
Replace fuel gauge gasket		Call DEK for parts/service

PRODUCTS COVERED BY THIS WARRANTY:	LENGTH OF WARRANTY:*		
	(FROM THE DATE OF ORIGINAL RETAIL PURCHASE)		
	NONCOMMERCIAL/ NON-RENTAL	COMMERCIAL	RENTAL
Engine	36 months / 300 hours	12 months / 300 hours	3 months / 300 hours
Battery	3 months	3 months	3 months
Alternator	36 months / 300 hours	12 months / 300 hours	3 months / 300 hours
Electrical and Frame Components	24 months / 300 hours	12 months / 300 hours	3 months / 300 hours
Emission Controls	36 months	36 months	36 months

\*LENGTH OF WARRANTY: All warranty coverage expires when the operating hours exceed 300 hours.

**TO QUALIFY FOR THIS WARRANTY:**

The product must be purchased in the United States from a dealer authorized by GXi Outdoor Power, LLC to sell those products. This warranty applies to first retail purchaser / owner during the applicable warranty time period. **SAVE YOUR PROOF OF PURCHASE RECEIPT.**

**WHAT DEK POWER EQUIPMENT WILL REPAIR OR REPLACE UNDER WARRANTY:**

DEK will repair or replace, at its option, any part that is proven to be defective in material or workmanship under normal use during the applicable warranty time period subject to the exclusions stated herein. This warranty is void if the owner fails to follow the prescribed maintenance and operating procedures described in this manual. This specifically refers to ensuring routine oil changes are made, that fuel stabilizer is used for long-term storage, that the generator is not overloaded, and that the generator loads are distributed evenly between the A and B outlets. Dirty carburetors, spark plugs, air filters, fuel filters, and freight or handling damage are not covered under warranty.

DEK has the right to recover warranty administration costs from the owner if the root cause of the malfunction was found to be other than defective material or workmanship. In particular, this warranty does not cover: contaminants in the fuel or oil; damage caused by not following the prescribed warnings and operating practices; failure to follow proper maintenance and storage procedures; and physical damage due to shipping or handling or storage. Damage to the generator that occurs as a result of connecting a DEK generator to household wiring without the use of a UL approved transfer switch device that is connected to the home or business and grounded as per applicable local electrical codes, is not covered by this warranty.

Warranty repairs will be made without charge for parts and labor for the first year. After the first year, this limited warranty covers the costs of replacement parts only.

Anything replaced under warranty becomes the property of DEK. Parts replaced under warranty will be considered as part of the original product and any warranty on those parts will expire coincident with the original product warranty.

**TO OBTAIN WARRANTY SERVICE:**

You must take the DEK Power Equipment product, accessory, replacement part, apparel or the power equipment on which the accessory or replacement part is installed, and proof of purchase, at your expense, to any DEK Power Equipment service location in the United States, who is authorized to service that product, during the service location's normal business hours. If you are unable to obtain warranty service, or are dissatisfied with the warranty service you receive, take the following steps: First, contact the manager of the service center involved; normally this will resolve the problem. However, if you should require further assistance, write or call the DEK Customer Service.

**EXCLUSIONS:**

THIS WARRANTY DOES NOT EXTEND TO PARTS AFFECTED OR DAMAGED BY ACCIDENT AND/OR COLLISION, NORMAL WEAR, FUEL CONTAMINATION, USE IN AN APPLICATION FOR WHICH THE PRODUCT WAS NOT DESIGNED OR ANY OTHER MISUSE, NEGLIGENCE, INCORPORATION OR USE OF UNSUITABLE ATTACHMENTS OR PARTS, UNAUTHORIZED ALTERATION, OR ANY CAUSES OTHER THAN DEFECTS IN MATERIAL OR WORKMANSHIP OF THE PRODUCT. Consumable parts such as oil, spark plugs, filters, carburetors, are not covered by this warranty.

**DISCLAIMER OF CONSEQUENTIAL DAMAGE AND LIMITATION OF IMPLIED WARRANTIES:**

DEK DISCLAIMS ANY RESPONSIBILITY FOR LOSS OF TIME OR USE OF THE PRODUCT, TRANSPORTATION, COMMERCIAL LOSS, OR ANY OTHER INCIDENTAL OR CONSEQUENTIAL DAMAGE. ANY IMPLIED WARRANTIES ARE LIMITED TO THE DURATION OF THIS WRITTEN LIMITED WARRANTY. This warranty is void if the manufacturing date and the serial number on the equipment has been removed or the equipment has been modified.

**EMISSION CONTROL SYSTEM INFORMATION**

The U.S. and California Clean Air Acts

EPA and California regulations require all manufacturers to furnish written instructions describing the operation and maintenance of emission control systems. The following instructions and procedures must be followed in order to keep the emissions from your DEK engine within the emission standards. Maintenance, replacement, or repair of the emission control devices and systems may be performed by any engine repair establishment or individual, using parts that are "certified" to EPA standards.

The emission control systems on your DEK engine were designed, built, and certified to conform with EPA regulations. We recommend the use of genuine DEK parts whenever you have maintenance done. These original-design replacement parts are manufactured to the same standards as the original parts, so you can be confident of their performance. The use of replacement parts that are not of the original design and quality may impair the effectiveness of your emission control system. A manufacturer of an aftermarket part assumes the responsibility that the part will not adversely affect emission performance. The manufacturer or re-builder of the part must certify that use of the part will not result in a failure of the engine to comply with emission regulations.

Emission controls are covered by this warranty for all uses for a period of 3 years from original retail purchase date, this coverage extends to subsequent owners of the product with proof of original purchase.