

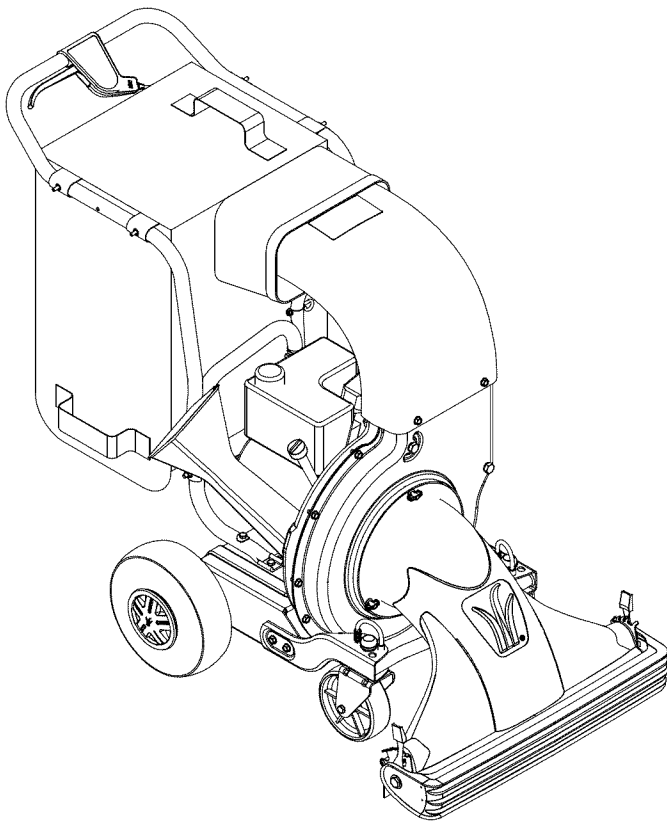

# Operator's Manual



## Chipper Shredder Vacuum

Model Number

203

### **IMPORTANT: READ SAFETY RULES AND INSTRUCTIONS CAREFULLY**

**Warning:** This unit is equipped with an internal combustion engine and should not be used on or near any unimproved forest-covered, brush-covered or grass-covered land unless the engine's exhaust system is equipped with a spark arrester meeting applicable local or state laws (if any). If a spark arrester is used, it should be maintained in effective working order by the operator. In the State of California the above is required by law (Section 4442 of the California Public Resources Code). Other states may have similar laws. Federal laws apply on federal lands. A spark arrester for the muffler is available through your nearest engine authorized service dealer or contact the service department, P.O. Box 361131 Cleveland, Ohio 44136-0019.

**MTD LLC P.O. BOX 361131 CLEVELAND, OHIO 44136-0019**

PRINTED IN U.S.A.

FORM NO. 770-10023E  
(7/03)

## TABLE OF CONTENTS

Content	Page
Important Safe Operation Practices.....	3
Assembling Your Chipper Shredder Vacuum .....	5
Know Your Chipper Shredder Vacuum .....	6
Operating Your Chipper Shredder Vacuum .....	7
Adjusting Your Chipper Shredder Vacuum .....	8
Maintaining Your Chipper Shredder Vacuum.....	9
Troubleshooting.....	13
Parts List.....	14

## FINDING MODEL NUMBER

This Operator's Manual is an important part of your new chipper shredder vacuum. It will help you assemble, prepare and maintain the unit for best performance. Please read and understand what it says.



**Before you start assembling your new equipment**, please locate the model plate on the equipment and copy the information from it in the space provided below. The information on the model plate is very important if you need help from our Customer Support Department or an authorized dealer.

- You can locate the model number by standing behind the unit and looking down at the frame below the engine. A sample model plate is explained below. For future reference, please copy the model number and the serial number of the equipment in the space below.

_____	_____
(Model Number)	(Serial Number)
	<b>MTD LLC</b> <b>P. O. BOX 361131</b> <b>CLEVELAND, OH 44136</b> <b>330-220-4683</b> <b>800-800-7310</b>
<a href="http://www.yardman.com">www.yardman.com</a>	

Copy the model number here: \_\_\_\_\_

Copy the serial number here: \_\_\_\_\_

## ENGINE INFORMATION

The engine manufacturer is responsible for all engine-related issues with regards to performance, power-rating, specifications, warranty and service. Please refer to the engine manufacturer's Owner's/Operator's Manual packed separately with your unit for more information.

## CALLING CUSTOMER SUPPORT

**Please do NOT return the unit to the retailer from which it was purchased, without first contacting Customer Support.**

Should you have difficulty assembling this product or have any questions regarding the controls, operation or maintenance of this unit, please call the Customer Support Department.



Call **1- (330) 220-4MTD (4683)** or **1- (800)-800-7310** to reach a Customer Support representative. Please have your unit's model number and serial number ready when you call. See previous section to locate this information. You will be asked to enter the serial number in order to process your call.

**For more details about your unit, visit our website at [www.yardman.com](http://www.yardman.com)**

---

## SECTION 1: IMPORTANT SAFE OPERATION PRACTICES



**WARNING:** This symbol points out important safety instructions which, if not followed, could endanger the personal safety and/or property of yourself and others. Read and follow all instructions in this manual before attempting to operate this machine. Failure to comply with these instructions may result in personal injury. When you see this symbol - **heed its warning.**

**WARNING:** The Engine Exhaust from this product contains chemicals known to the State of California to cause cancer, birth defects or other reproductive harm.

**DANGER:** This machine was built to be operated according to the rules for safe operation in this manual. As with any type of power equipment, carelessness or error on the part of the operator can result in serious injury. This machine is capable of amputating hands and feet and throwing objects. Failure to observe the following safety instructions could result in serious injury or death.

### TRAINING

1. Read, understand, and follow all instructions on the machine and in the manual(s) before attempting to assemble and operate. Keep this manual in a safe place for future and regular reference and for ordering replacement parts.
  2. Be familiar with all controls and their proper operation. Know how to stop the machine and disengage them quickly.
  3. Never allow children under 16 years old to operate this machine. Children 16 years old and over should read and understand the operation instructions and safety rules in this manual and should be trained and supervised by a parent.
  4. Never allow adults to operate this machine without proper instruction.
  5. Keep bystanders, helpers, pets, and children at least 75 feet from the machine while it is in operation. Stop machine if anyone enters the area.
  6. Never run an engine indoors or in a poorly ventilated area. Engine exhaust contains carbon monoxide, an odorless and deadly gas.
  7. Do not put hands and feet near rotating parts or in the feeding chambers and discharge opening. Contact with the rotating impeller can amputate fingers, hands, and feet.
  8. Never attempt to unclog either the feed intake or discharge opening, remove or empty vacuum bag, or inspect and repair the machine while the engine is running. Shut the engine off and wait until all moving parts have come to a complete stop. Disconnect the spark plug wire and ground it against the engine.
2. Always wear safety glasses or safety goggles during operation or while performing an adjustment or repair, to protect eyes. Thrown objects which ricochet can cause serious injury to the eyes.
  3. Wear sturdy, rough-soled work shoes and close-fitting slacks and shirts. Loose fitting clothes or jewelry can be caught in movable parts. Never operate this machine in bare feet or sandals. Wear leather work gloves when feeding material in the chipper chute.
  4. Before starting, check all bolts and screws for proper tightness to be sure the machine is in safe working condition. Also, visually inspect machine for any damage at frequent intervals.
  5. Maintain or replace safety and instructions labels, as necessary.
  6. To avoid personal injury or property damage use extreme care in handling gasoline. Gasoline is extremely flammable and the vapors are explosive. Serious personal injury can occur when gasoline is spilled on yourself or your clothes which can ignite. Wash your skin and change clothes immediately.
    - a. Use only an approved gasoline container.
    - b. Extinguish all cigarettes, cigars, pipes, and other sources of ignition.
    - c. Never fuel machine indoors.
    - d. Never remove gas cap or add while the engine is hot or running.
    - e. Allow engine to cool at least two minutes before refueling.
    - f. Never over fill fuel tank. Fill tank to no more than 1/2 inch below bottom of filler neck to provide space for fuel expansion.
    - g. Replace gasoline cap and tighten securely.
    - h. If gasoline is spilled, wipe it off the engine and equipment. Move machine to another area. Wait 5 minutes before starting the engine.
    - i. Never store the machine or fuel container inside where there is an open flame, spark, or pilot light (e.g. furnace, water heater, space heater, clothes dryer, etc.)

### PREPARATION

1. Thoroughly inspect the area where the equipment is to be used. Remove all rocks, bottles, cans, or other foreign objects which could be picked up or thrown and cause personal injury or damage to the machine.

- j. To reduce a fire hazard, keep machine free of grass, leaves, or other debris build-up. Clean up oil or fuel spillage and remove any fuel soaked debris.
- k. Allow machine to cool at least 5 minutes before storing.

## OPERATION

1. Do not put hands and feet near rotating parts or in the feeding chambers and discharge opening. Contact with the rotating impeller can amputate fingers, hands, and feet.
2. Before starting the machine, make sure the chipper chute, feed intake, and cutting chamber are empty and free of all debris.
3. Thoroughly inspect all material to be shredded and remove any metal, rocks, bottles, cans, or other foreign objects which could cause personal injury or damage to the machine.
4. If the impeller strikes a foreign object or if your machine should start making an unusual noise or vibration, immediately shut the engine off. Allow the impeller to come to a complete stop. Disconnect the spark plug wire, ground it against the engine and perform the following steps:
  - a. Inspect for damage.
  - b. Repair or replace any damaged parts.
  - c. Check for any loose parts and tighten to assure continued safe operation.
6. Do not allow an accumulation of processed material to build up in the discharge area. This can prevent proper discharge and result in kickback of material through the feed opening.
7. Do not attempt to shred or chip material larger than specified on the machine or in this manual. Personal injury or machine damage could result.
8. Never attempt to unclog either the feed intake or discharge opening while the engine is running. Shut the engine off, wait until all moving parts have stopped, disconnect the spark plug wire and ground it against the engine before clearing debris.
9. Never operate without vacuum bag and discharge chute properly attached to the machine. Never empty or change vacuum bag while the engine is running. Zippered end of vacuum bag must be kept closed at all times during operation.
10. Never operate without either the inlet nozzle or optional hose attachment properly attached to the machine. Never attempt to attach or change either attachment while the engine is running.
11. Keep all guards, deflectors and safety devices in place and operating properly.
12. Keep your face and body back and to the side of the chipper chute while feeding material into the machine to avoid accidental kickback injuries.
13. Never operate this machine without good visibility or light. Always be sure of your footing and keep a firm hold on the handles.
14. Do not operate this machine on a gravel surface.
15. Do not operate this machine while under the influence of alcohol or drugs.
16. Muffler and engine become hot and can cause a burn. Do not touch.
17. Never pick up or carry machine while the engine is running.

## MAINTENANCE AND STORAGE

1. Never tamper with safety devices. Check their proper operation regularly.
2. Check bolts and screws for proper tightness at frequent intervals to keep the machine in safe working condition. Also, visually inspect machine for any damage and repair, if needed.
3. Before cleaning, repairing, or inspecting, stop the engine and make certain the impeller and all moving parts have stopped. Disconnect the spark plug wire and ground it against the engine to prevent unintended starting.
4. Do not change the engine governor settings or overspeed the engine. The governor controls the maximum safe operating speed of the engine.
5. Maintain or replace safety and instruction labels, as necessary.
6. Follow this manual for safe loading, unloading, transporting, and storage of this machine.
7. Never store the machine or fuel container inside where there is an open flame, spark or pilot light such as a water heater, furnace, clothes dryer, etc.
8. Always refer to the operator's manual for proper instructions on off-season storage.
9. If the fuel tank has to be drained, do this outdoors.
10. Observe proper disposal laws and regulations for gas, oil, etc. to protect the environment.



**WARNING: - YOUR RESPONSIBILITY:** Restrict the use of this power machine to persons who read, understand and follow the warnings and instructions in this manual and on the machine.

**NOTE:** Not all safety labels shown may apply to your chipper shredder vacuum.

**⚠ WARNING**

**TO AVOID SERIOUS INJURY**

- Read Owner's Manual and all safety labels on machine before starting and using machine.
- Keep hands, feet, face, long hair and clothing out of chipper inlet, vac inlet, and discharge area. There are **ROTATING BLADES** inside these openings.
- Wear approved safety glasses and gloves. Avoid loose fitting clothes.
- Keep the area of operation clear of all persons, particularly small children and pets.
- Keep all shields and guards (e.g. upper chipper chute extension, discharge chute, nozzle assembly) in place and securely attached.
- Check bag frequently for wear. Replace if worn or damaged.
- If unit becomes clogged or jammed, shut off engine right away. Do not attempt to clear clog or jam with engine running. Refer to Maintenance Section of Owner's Manual for unclogging instructions.
- Muffler and engine get hot and can cause burns. Do not touch. To avoid a fire hazard, keep leaves, grass, and other combustible debris off hot muffler and engine.
- Do not attempt to remove or attach vac nozzle or optional Hose Kit with engine running. Do not operate unit unless nozzle or optional Hose Kit is secured in place.
- Do not fill gas tank while engine is running. Allow engine to cool at least 2 minutes before refueling.

⚠ CAUTION

DO NOT OPERATE THIS UNIT WITHOUT ENTIRE BAG AND DISCHARGE CHUTE IN PLACE. TURN THE ENGINE OFF AND ALLOW THE IMPELLER TO COME TO A COMPLETE STOP BEFORE REMOVING THE BAG.

S30131

⚠ WARNING

ROTATING BLADES INSIDE. KEEP HANDS AWAY FROM ALL OPENINGS. DO NOT REMOVE OR ATTACH NOZZLE OR OPTIONAL HOSE KIT WHEN ENGINE IS RUNNING!

S30133

## SECTION 2: ASSEMBLING YOUR CHIPPER SHREDDER VACUUM

**IMPORTANT:** This unit is shipped without gasoline or oil in the engine. Be certain to service engine with gasoline and oil as instructed in the separate engine manual before operating your machine.

**NOTE:** Reference to right or left hand side of the chipper shredder vacuum is observed from the operating position.

### Removing Unit From Carton

- Remove staples, break glue on top flaps, or cut tape at carton end and peel along top flap to open carton.
- Remove loose parts if included with unit (i.e., operator's manual, etc.)
- Cut along corners, lay carton down flat, and remove packing material.
- Roll or slide unit out of carton and check carton thoroughly for loose parts.

### Loose Parts In Carton (See Figure 1)

- Nozzle
- Bag



**WARNING:** Before setting up your chipper shredder vacuum, disconnect the spark plug wire from the spark plug and ground against the engine.

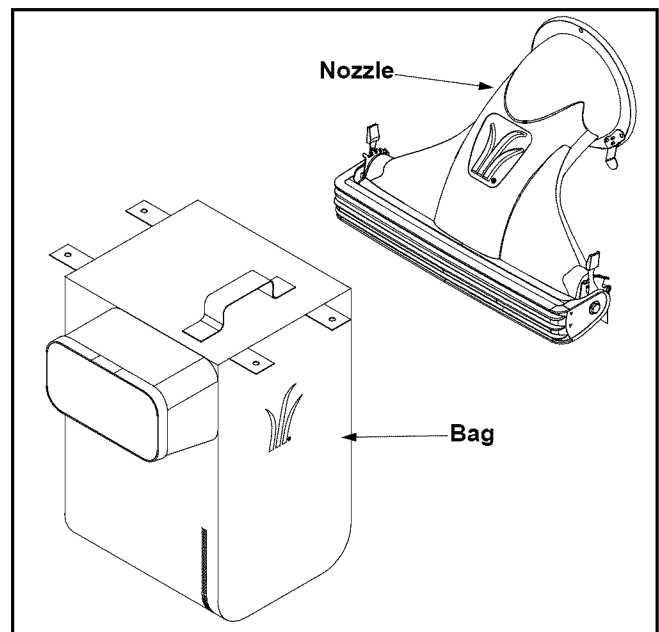

Figure 1

## Attaching The Nozzle

- Remove three wing nuts from the front of the chipper shredder vacuum.
- Place nozzle in position over the three studs on unit and secure with wing nuts just removed. See Figure 2.

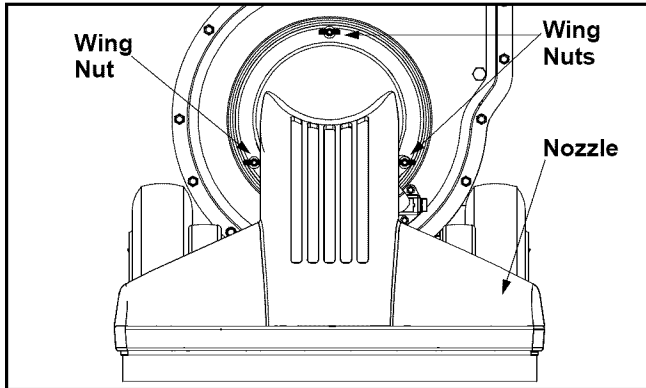

Figure 2

**NOTE:** The metal tab on the nozzle must depress the safety switch button attached to the front of chipper shredder vacuum or the engine will not start.

## Attaching The Bag

- Place bag under of upper handle assembly and slip the front opening on the bag over the discharge chute, making certain it is over the rim on the discharge chute. See Figure 3.

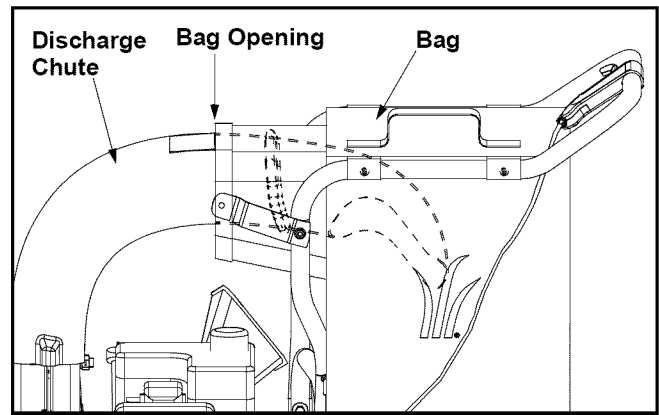

Figure 3

- Place the four straps on the top of the bag **over** upper handle, hooking them on the studs to secure in place. Squeeze the clamp on the drawstring and pull the drawstring tight. Release the clamp. See Figure 4.

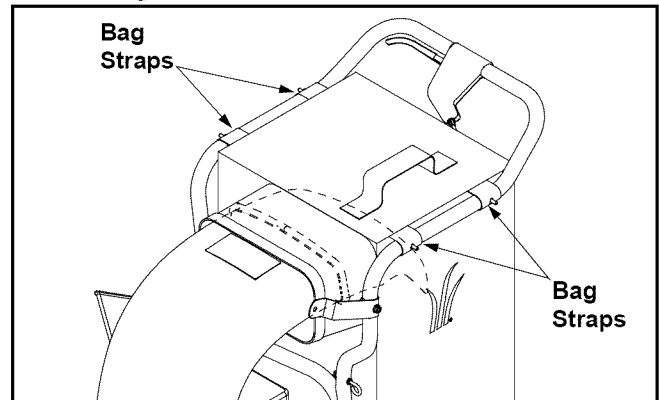

Figure 4

## SECTION 3: KNOW YOUR CHIPPER SHREDDER VACUUM



**WARNING:** Be familiar with all controls and their proper operation. Know how to stop the machine and disengage them quickly.

### Bag

Collects shredded or chipped material fed through the chipper chute or vacuumed up through the nozzle. See Figure 5.

### Chipper Chute

Allow twigs and small branches up to 2" in diameter to be fed into the impeller for chipping. See Figure 5.

### Caster Locks

The caster locks are located on top of each front caster wheel. Refer to the Adjustment Section to position wheel locks. See Figure 5.

### Nozzle Door Adjustment Levers

The nozzle adjustment levers are located on each side of the nozzle door. They are used to adjust the nozzle door for ground clearance that will provide the best performance for the operating conditions. See Figure 5.

### Nozzle

Yard waste such as leaves and pine needles can be vacuumed up through the nozzle for shredding. See Figure 5.

### Drive Clutch Control

The drive clutch control is located on the upper handle assembly. Squeezing the drive clutch control against the upper handle engages the rear wheels. Release the drive clutch control to slow down or stop the wheel drive. See Figure 5.

### Throttle Control Lever (Not Shown)

The throttle control lever is located on the engine. It controls the engine's speed and stops the engine. See separate engine manual packed with unit for details.

### Starter Handle (Not Shown)

The starter handle is located on the engine. Pull the starter handle to start engine.

### Engine Controls

See the separate engine manual for the location and function of the controls on the engine.

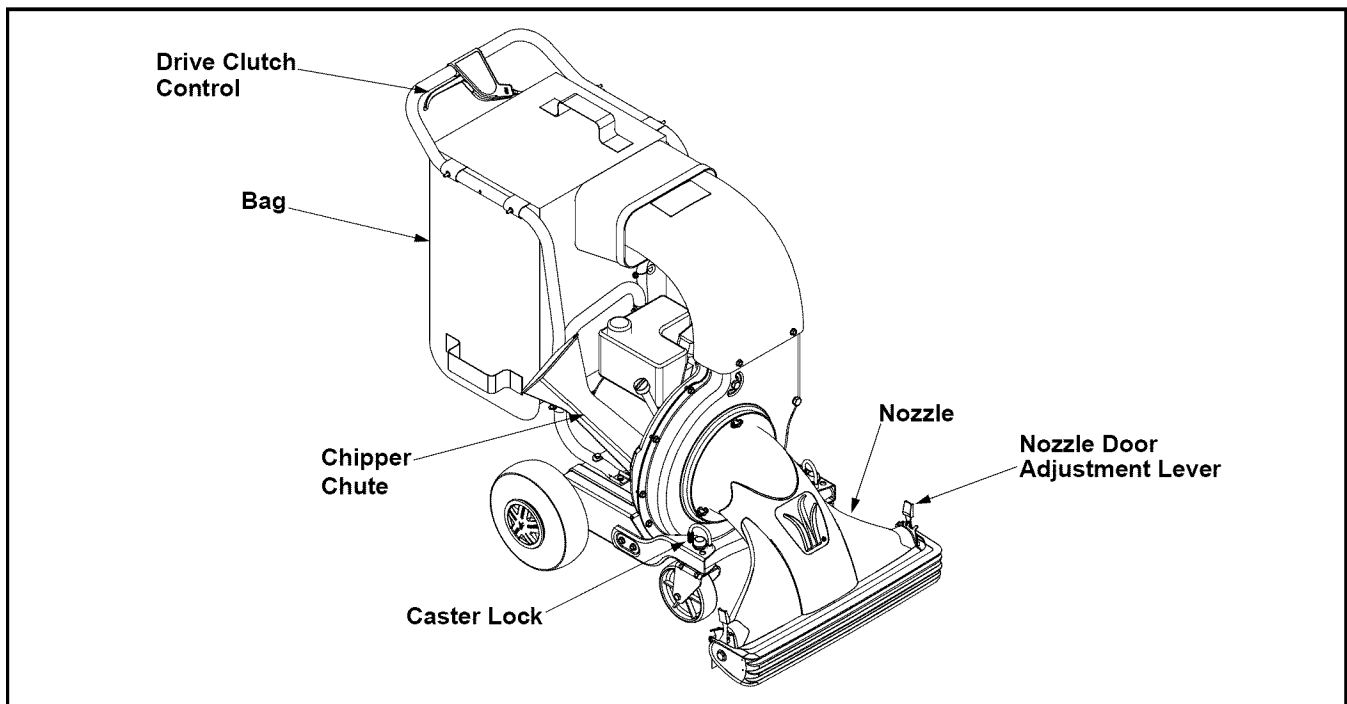

Figure 5

## SECTION 4: OPERATING YOUR CHIPPER SHREDDER VACUUM



**WARNING:** Read, understand, and follow all instructions and warnings on the machine and in this manual before operating.



Always wear the safety glasses provided with this machine during operation or while performing any adjustments or repairs. Thrown objects which ricochet can cause serious injury to the eyes.

### Gas And Oil Fill-Up

Service the engine with gasoline and oil as instructed in the separate engine manual packed with your chipper shredder vacuum. Read instructions carefully.



**WARNING:** Use extreme care when handling gasoline. Gasoline is extremely flammable and the vapors are explosive. Never fuel machine indoors or while the engine is hot or running. Extinguish cigarettes, cigars, pipes, and other sources of ignition.

### Starting Engine

- Attach spark plug wire to spark plug. Make certain the metal cap on the end of the spark plug is fastened securely over the metal tip on the spark plug.

- Make certain drive clutch control is in the disengaged (released) position.
- **Engines with choke lever:** Move choke lever on engine to CHOKE position. (A warm engine may not require choking).
- **Engines with primer:** Prime engine as instructed in separate engine manual.
- The throttle control lever is located on the engine. Move engine throttle control lever to FAST or START position.
- Place one foot on the left rear wheel to prevent the unit from skidding while starting.
- Grasp starter handle and pull rope out slowly until engine reaches start of compression cycle (rope will pull slightly harder at this point).

**NOTE:** A noise will be heard when at the start of the compression cycle. This noise should be expected until the impeller reaches full speed.

- Pull rope with a rapid, continuous, full arm stroke. Keep a firm grip on starter handle. Let rope rewind slowly.
- Repeat the previous steps until engine fires. When engine starts, move choke control (if equipped) gradually to RUN position.



**WARNING:** Keep bystanders, helpers, pets, and children at least 75 feet from the machine before starting and while operating. Do not operate this machine unless the discharge chute and bag have been properly installed and secured to the machine.

## Stopping Engine

- Move throttle control lever to STOP or OFF position.
- Disconnect spark plug wire from spark plug and ground against the engine.

## To Empty Bag

The bag is designed to be emptied without being removed from unit. Open the large zipper in the rear of the bag to empty the contents. If bag is removed for any reason, follow the instructions for attaching the bag in the ASSEMBLY section. Be certain the zipper is closed completely when operating the unit.

## To Engage Drive

To engage the wheel drive, hold the drive clutch control against the upper handle. Releasing the drive clutch control stops the rear wheels from driving. Release the drive clutch control to slow down when negotiating an obstacle, making a turn, or stopping. Engage control slowly to prevent the front wheels from lifting up.

## Using the Chipper Shredder Vacuum

Place both hands on top of upper handle to push unit over yard waste. Yard waste such as leaves and pine needles can be vacuumed up through the nozzle for shredding. After material has been shredded by the blades on the impeller assembly, it will be discharged into catcher bag. Do not attempt to shred or chip any material other than vegetation found in a normal yard (i.e. branches, leaves, twigs, etc.) Avoid fibrous plants such as tomato vines until they are thoroughly dried out. Materials such as stalks or heavy branches up to 2" in diameter may be fed into the chipper chute. See Figure 6.



**WARNING:** Do not attempt to shred, chip, or vacuum any material larger than specified on the machine or in this manual. Personal injury or damage to the machine could result.

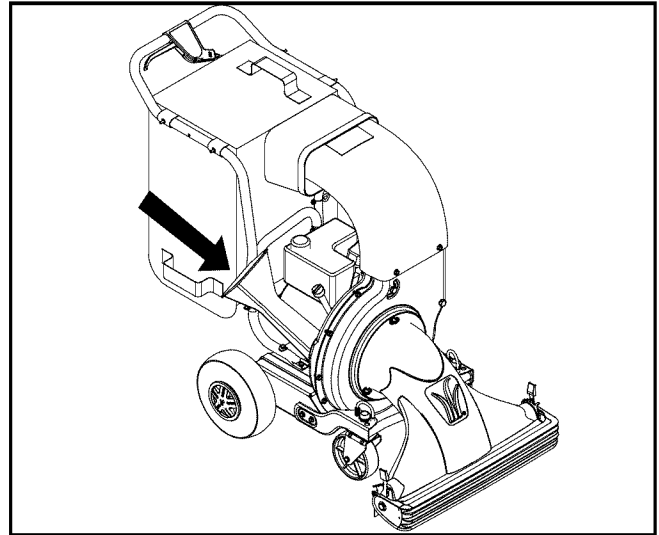

**Figure 6**

**IMPORTANT:** The flail screen is located inside the housing in the discharge area. If the flail screen becomes clogged, remove and clean as instructed in MAINTAINING YOUR CHIPPER SHREDDER VACUUM. For best performance, it is also important to keep the chipper blade sharp.

## Tire Pressure (Pneumatic Tires Only)



**WARNING:** Maximum tire pressure under any circumstance is 30 psi. Equal tire pressure should be maintained at all times.

---

# SECTION 5: ADJUSTING YOUR CHIPPER SHREDDER VACUUM



**WARNING:** Do not at any time make any adjustments without first stopping engine, disconnecting spark plug wire, and grounding it against the engine.

## Front Caster Wheels

This chipper shredder vacuum is equipped with front caster wheels. The casters can be locked in a straight ahead position or position to swivel freely. Lift and place pins in the larger holes for locked or straight ahead operation. Place pins in smaller holes to allow casters to rotate freely. Lock wheels in straight position when operating on slopes. See Figure 7.



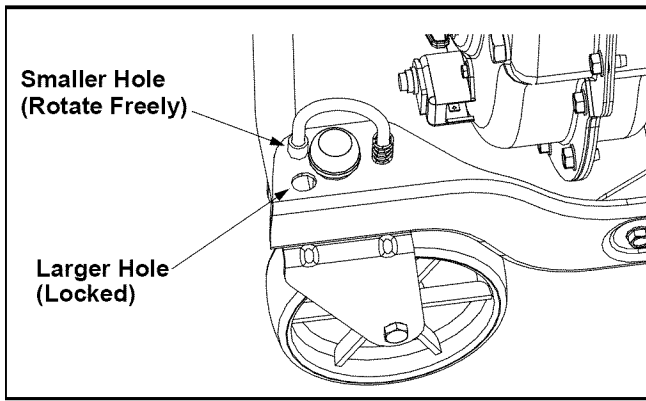

Figure 7

## Nozzle Door Height Adjustment

The nozzle adjustment levers are located on each side of the nozzle door. The nozzle door can be adjusted to any of five positions, ranging from 1/2" to 3" ground clearance that will provide the best performance for the operating conditions. Slide the height adjustment lever forward or backward for adjusting the nozzle door upwards or downwards. Height must be adjusted equally. In general, raise the nozzle to vacuum a thick layer of leaves and lower the nozzle for smooth surfaces. See Figure 8.

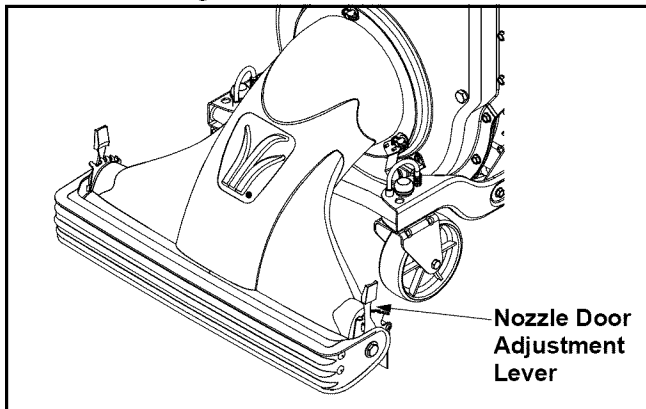

Figure 8

## Drive Clutch Cable Adjustment

Adjust the drive clutch control if the chipper shredder vacuum moves forward with the drive clutch control disengaged, if it does not self-propel with the drive clutch control engaged, or if drive belt is slipping (unit hesitates while engine maintains the same speed). Use the adjustment wheel located in the clutch control housing to tighten or loosen the clutch cable. In addition, the adjustment wheel may also be used to determine the position in which the drive clutch control is engaged. If it is more comfortable to have the drive engaged with the lever further away from the handle, tighten the clutch cable. See Figure 9.

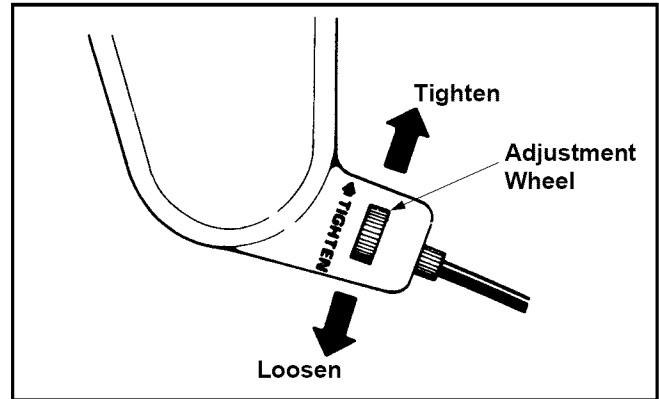

Figure 9

## Engine Adjustments

Refer to the separate engine manual for engine adjustment instructions.

# SECTION 6: MAINTAINING YOUR CHIPPER SHREDDER VACUUM



**WARNING:** Before performing any maintenance or repairs, stop the engine, wait until the machine comes to a complete stop, disconnect the spark plug wire and ground against the engine to prevent unintended starting.

## Lubrication (Refer to Figure 5)

**Wheels:** Lubricate the rear wheels with light oil once a season.

**Nozzle Door Adjustment Levers:** Lubricate each adjustment lever once a season with light oil.

**Front Caster Wheels:** Grease fittings are located on the front caster wheels to provide easy lubrication of the swivel pins once a season.

# Customer Responsibilities

MAINTENANCE SCHEDULE		Before each use	Every 25 hours	Every 50 hours	Every 100 hours	Once a season	Before storage	SERVICE DATES					
PRODUCT	Lubricate Wheels					✓							
	Lubricate Adjustment Levers					✓							
	Lubricate Caster Wheels					✓							
	Check Chipper Blades		✓			✓							
ENGINE	Check Oil	✓											
	Change Oil		✓				✓						
	Check Air Filter		✓			✓							
	Clean Engine	✓					✓						
	Check Spark Plug			✓		✓							

## Maintenance

### Engine

Refer to the separate engine manual for all engine maintenance instructions.

- Check **engine oil level** before each use as instructed in the separate engine manual packed with your unit. Read and follow instructions carefully.
- Clean **air cleaner** every 25 hours under normal conditions or once a season. Clean every few hours under extremely dusty conditions. To service the air cleaner, refer to the separate engine manual packed with your unit.
- The **spark plug** should be cleaned and the gap reset once a season. Check engine manual for correct plug type and gap specifications.

## Removing The Flail Screen

If the discharge area becomes clogged, remove the flail screen and clean area as follows:

- Stop the engine and make certain the chipper shredder vacuum has come to a complete stop.
- Disconnect spark plug wire from spark plug and ground against the engine.
- Remove the vacuum bag from the unit.
- Remove the four self-tapping screws from the bottom of the discharge chute, and the hex bolt, flat washer and hex nut from the top. Remove the discharge chute assembly. See Figure 10.
- Remove the two hex bolts and hex nuts which extend through the impeller housing. Lift the flail screen from the inside the housing. See Figure 10.
- Clean the screen by scraping or washing with water and reinstall the screen.

**NOTE:** Be certain to reassemble the flail screen with the curved side down.

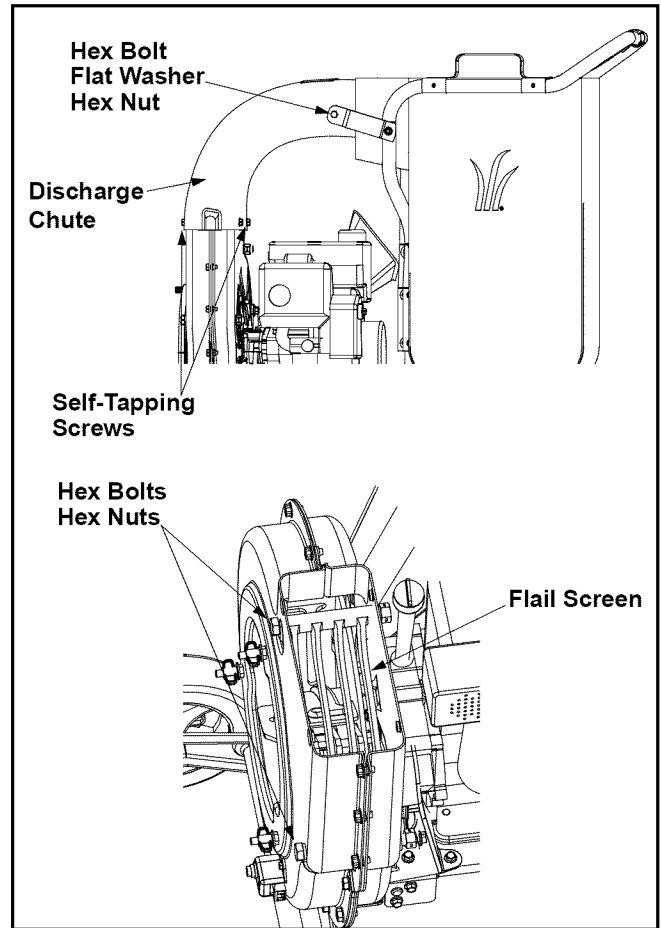

Figure 10

- Reattach the discharge chute assembly with the hardware previously removed and connect the bag to unit.

## Sharpening Or Replacing Chipper Blades

**NOTE:** When tipping the unit, empty the fuel tank and keep spark plug side up.

- Disconnect the spark plug wire and ground it against the engine.
- Remove the flail screen as instructed in the previous section.
- Remove the plastic belt cover on the front of the engine by removing the two self-tapping screws. See Figure 11.
- Remove the access plate by removing two hex lock nuts. See Figure 11.
- Locate one of the chipper blades in the access opening by rotating the impeller assembly by hand. Remove the chipper blade using a 3/16" allen wrench and a 1/2" wrench.
- Remove other blade in the same manner to replace or sharpen.

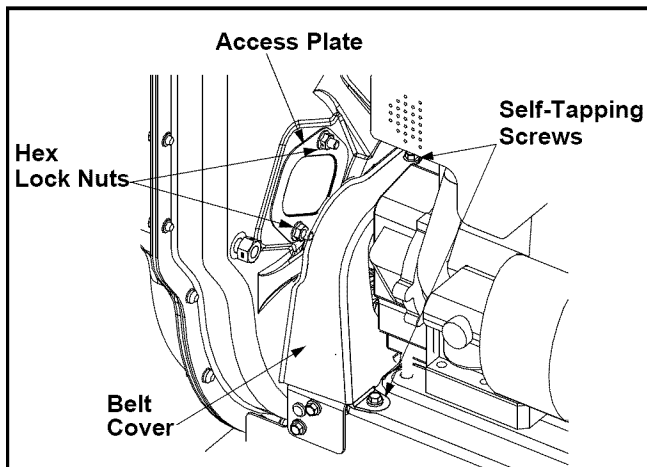

Figure 11



**WARNING:** Use caution when replacing the blades, wear heavy gloves to avoid a contact injury with the weld bolts or the housing while loosening or tightening the blades.

- When sharpening blades, follow the original angle of grind. Also, make sure to remove an equal amount from each blade and torque hardware 250 - 300 in. lbs.

**NOTE:** Make certain blades are reassembled with the sharp edge facing upward.

## Belt Removal And Replacement

**NOTE:** Because the engine on this has a tapered crankshaft, a special impeller removal tool (part number 753-0638) is required to remove impeller assembly. Contact your local service dealer.

- Disconnect the spark plug wire and ground it away from the spark plug.
- Drain the gasoline and oil from the chipper shredder vacuum.

- Remove the three wing nuts that secure the nozzle to the outer housing and remove the nozzle. Refer to Figure 2.
- Remove the vacuum bag from the unit.
- Remove the discharge chute as instructed in the previous section Removing The Flail Screen.
- Remove the plastic belt cover on the front of the engine by removing two self-tapping screws. Refer to Figure 11.
- Tip the unit backward so that it rests on the handles.
- Remove the lower belt guard by removing the two self-tapping screws. See Figure 12.

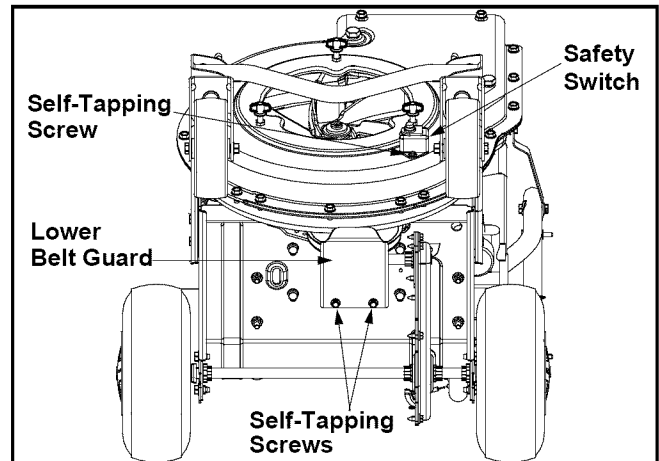

Figure 12

- Remove the safety switch from the front of the outer housing by removing the two self-tapping screws. See Figure 12.
- Remove the two hex bolts and hex lock nuts which extend through the housing. Lift the flail screen out of the housing. Refer to Figure 10.
- Remove the outer housing and housing blades by removing the fourteen self-tapping screws.
- Remove the hex bolt, lock washer, and flat washer that secures the impeller assembly to the crankshaft. See Figure 13.

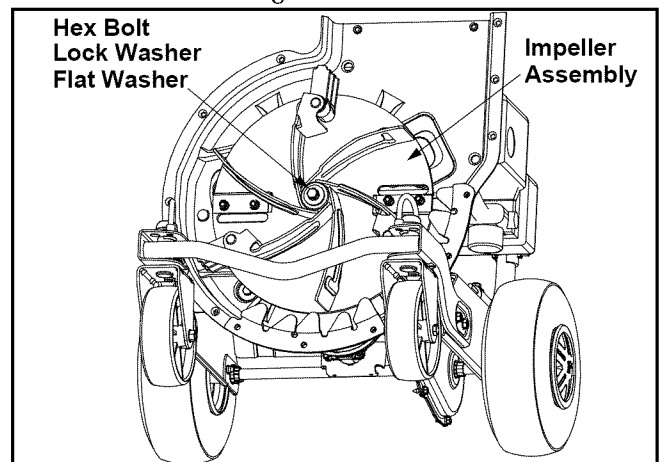
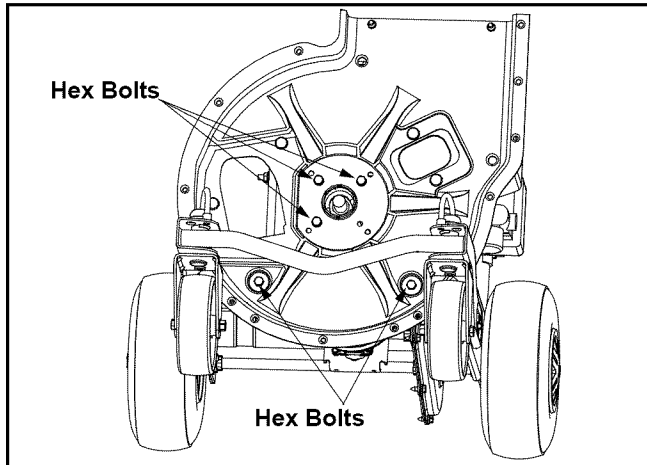

Figure 13

- Thread the special impeller tool into the crankshaft. Stop when the impeller assembly can move on the crankshaft.

- If the old belt is still on the unit, cut belt to remove from unit.
- Remove the impeller assembly from the crankshaft and unthread the special impeller tool from the impeller assembly.
- Remove the inner housing and mounting adapter by removing the five hex bolts and two hex nuts. See Figure 14.



**Figure 14**

- Insert the new belt between the frame and transmission pulley. It may be necessary to use a screwdriver to pry the frame away from the pulley in order to insert the belt. Being careful not to damage the pulley, apply a slight upward pressure and place belt around transmission pulley. See Figure 15.

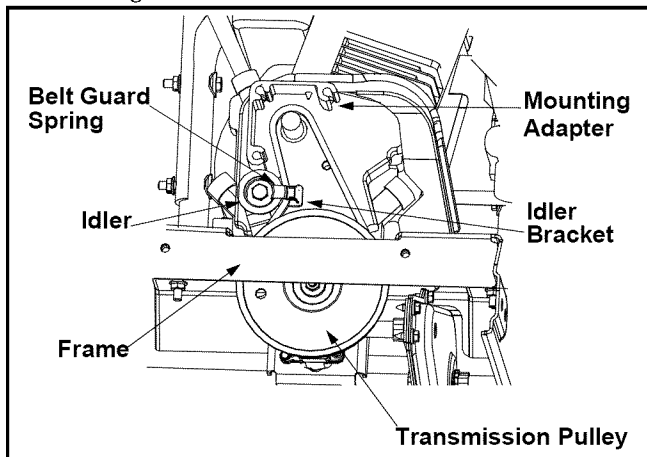

**Figure 15**

- Press down on the belt guard spring by the idler pulley and release spring from the slot on the idler bracket. Place the belt on the idler pulley and place belt guard spring back into the slot on the idler bracket. See Figure 15.

- Place the mounting adapter against the engine and make sure the hole in the mounting adapter is facing up.
- Place the inner housing against mounting adapter and frame. Secure with the five hex bolts and two hex nuts previously removed. Refer to Figure 14.
- Slide the impeller assembly onto the crankshaft and place a screwdriver under the belt. Turn the impeller assembly counterclockwise to seat the belt into the slot on the impeller. Make sure the belt is routed inside all belt guards.
- Secure the impeller assembly to the crankshaft using the hex bolt, lock washer, and flat washer previously removed. Torque the bolt to 550 in. lbs. to 700 in. lbs.
- Place the housing blades against the inner housing. See Figure 16.

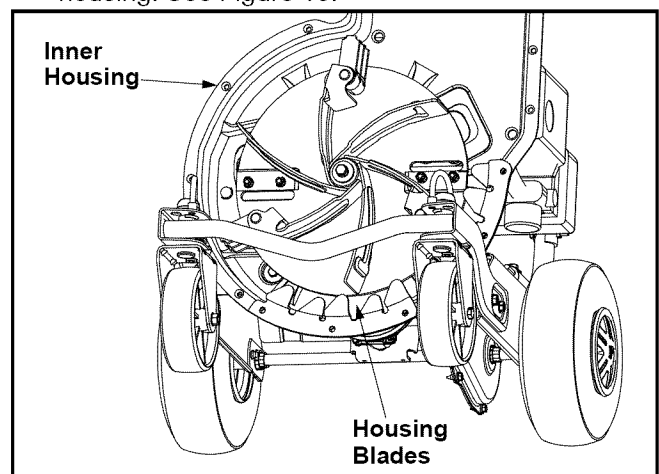

**Figure 16**

- Place the outer housing against the inner housing. Insert two screwdrivers into the holes to hold the blades in place while attaching the outer housing. See Figure 17.
- Secure with the fourteen self tapping screws that were previously removed and insert all screws first before tightening.
- Reassemble following the previous steps in reverse order.

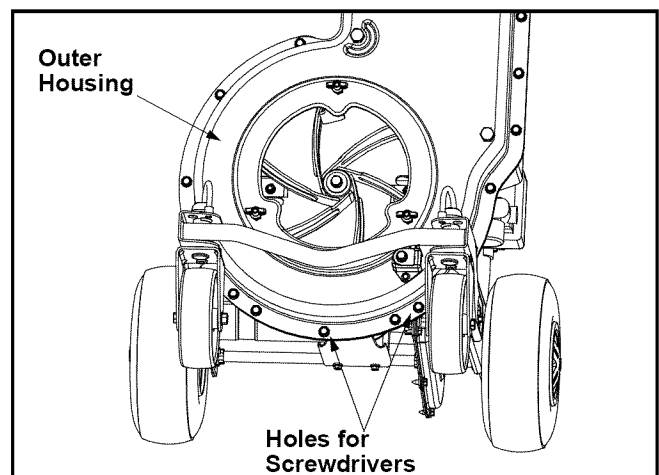

**Figure 17**

## Storing Your Chipper Shredder Vacuum

- Clean the equipment thoroughly.
- Wipe equipment with an oiled rag to prevent rust.
- Refer to engine manual for correct engine storage instructions
- Store unit in a clean, dry area. Do not store next to corrosive materials such as fertilizer.



**WARNING:** Never store the machine or fuel container indoors where there is an open flame, spark, or pilot light such as on a water heater, furnace, clothes dryer, or other gas appliance.

## SECTION 7: TROUBLESHOOTING

Problem	Cause	Remedy
Engine fails to start	<ol style="list-style-type: none"> <li>1. Spark plug wire disconnected.</li> <li>2. Fuel tank empty or stale fuel.</li> <li>3. Throttle control lever not in correct starting position.</li> <li>4. Choke not in CHOKE position. (If Equipped)</li> <li>5. Engine (if equipped with a primer) not primed properly.</li> <li>6. Blocked fuel line.</li> <li>7. Faulty spark plug.</li> </ol>	<ol style="list-style-type: none"> <li>1. Connect wire to spark plug.</li> <li>2. Fill tank with clean, fresh gasoline.</li> <li>3. Move throttle lever to FAST position.</li> <li>4. Move choke to CHOKE position.</li> <li>5. Prime engine.</li> <li>6. Clean fuel line.</li> <li>7. Clean, adjust gap, or replace.</li> </ol>
Engine runs erratic	<ol style="list-style-type: none"> <li>1. Spark plug wire loose.</li> <li>2. Unit running on CHOKE. (If Equipped)</li> <li>3. Blocked fuel line or stale fuel.</li> <li>4. Water or dirt in fuel system.</li> <li>5. Dirty air cleaner.</li> <li>6. Carburetor out of adjustment.</li> </ol>	<ol style="list-style-type: none"> <li>1. Connect and tighten spark plug wire.</li> <li>2. Move choke lever to OFF position.</li> <li>3. Clean fuel line; fill tank with clean, fresh gasoline.</li> <li>4. Drain fuel tank. Refill with fresh fuel.</li> <li>5. Clean or replace air cleaner.</li> <li>6. See authorized service dealer.</li> </ol>
Too much vibration	<ol style="list-style-type: none"> <li>1. Loose parts or damaged impeller.</li> </ol>	<ol style="list-style-type: none"> <li>1. See authorized service dealer.</li> </ol>
Engine overheats	<ol style="list-style-type: none"> <li>1. Engine oil level low.</li> <li>2. Dirty air cleaner.</li> <li>3. Carburetor not adjusted properly.</li> </ol>	<ol style="list-style-type: none"> <li>1. Fill crankcase with proper oil.</li> <li>2. Clean or replace air cleaner.</li> <li>3. See authorized service dealer.</li> </ol>
Occasional skip (hesitates) at high speed	<ol style="list-style-type: none"> <li>1. Spark plug gap too close.</li> </ol>	<ol style="list-style-type: none"> <li>1. Adjust gap to .030".</li> </ol>
Unit does not discharge	<ol style="list-style-type: none"> <li>1. Discharge chute clogged.</li> <li>2. Foreign object lodged in impeller.</li> <li>3. Low engine RPM</li> <li>4. Vacuum bag is full.</li> </ol>	<ol style="list-style-type: none"> <li>1. Stop engine immediately and disconnect spark plug wire. Clean flail screen and inside of discharge opening.</li> <li>2. Stop engine and disconnect spark plug wire. Remove lodged object.</li> <li>3. Always run engine at full throttle.</li> <li>4. Empty bag.</li> </ol>
Rate of discharge slows considerably or composition of discharged material changes.	<ol style="list-style-type: none"> <li>1. Low engine RPM.</li> <li>2. Chipper blade dull.</li> </ol>	<ol style="list-style-type: none"> <li>1. Always run engine at full throttle.</li> <li>2. Replace chipper blade or see your authorized service dealer.</li> </ol>

**NOTE:** For repairs beyond the minor adjustments listed above, contact your nearest authorized service dealer.

## SECTION 8: PARTS LIST FOR MODEL 203

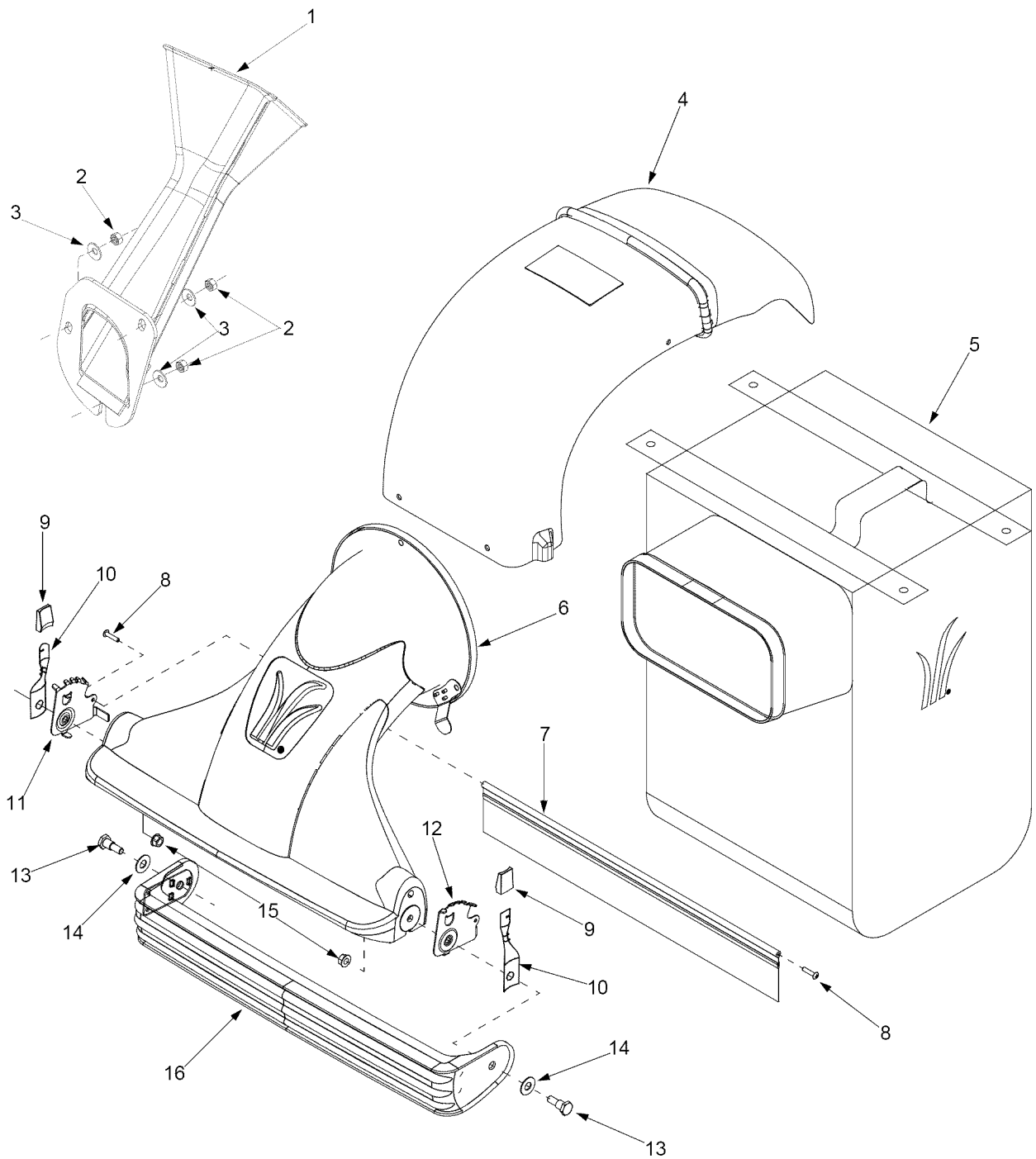

REF. NO.	PART NO.	DESCRIPTION	REF. NO.	PART NO.	DESCRIPTION
1	681-0095	Chipper Chute	9	720-0190	Height Adjustment Knob
2	712-3010	Hex Nut 5/16-18	10	732-0754	Spring Lever
3	736-0242	Bell Washer .340 ID x .872 OD	11	781-0702	Index Bracket RH
4	731-1690A	Discharge Chute	12	781-0703	Index Bracket LH
5	764-04001	Bag	13	738-0913	Shoulder Screw
6	631-0069	Nozzle Assembly	14	736-3084	Flat Washer .510 x 1.120 x .060
7	731-1831	Nozzle Flap	15	712-0431	Hex Flange Lock Nut 3/8-16
8	710-0969	Screw	16	631-0047	Door Assembly

# Model 203

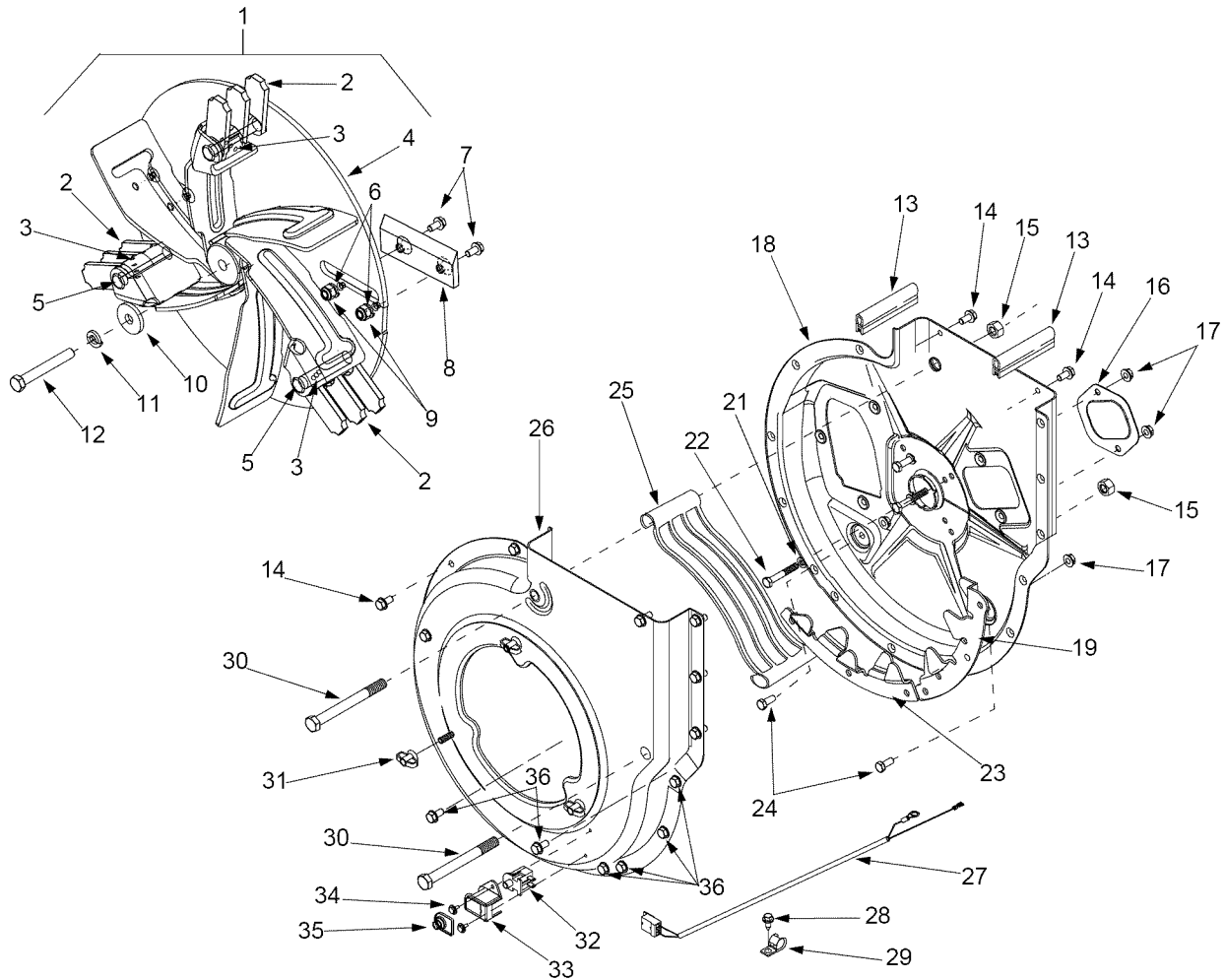

Ref. No.	Part No.	Part Description	Ref. No.	Part No.	Part Description
1.	681-0108	Impeller Assembly Complete	19.	781-0599	Upper Shredder Blade
2.	719-0329	Flail Blade	21.	736-0119	Lock Washer 5/16
3.	715-0166	Spiral Pin	22.	710-0772	Hex Cap Screw 5/16-18 x 2
4.	681-0107	Impeller Assembly	23.	781-0653	Flail Housing Blade
5.	711-0833B	Clevis Pin	24.	710-3008	Hex Cap Screw 5/16-18 x .75
6.	736-0119	Lock Washer 5/16	25.	719-0326	Discharge Screen
7.	710-1054	Cap Screw 5/16-24 x 1.0	26.	681-0060	Outer Flail Housing Assembly
8.	781-0490	Chipper Blade	27.	629-0241A	Wire Harness
9.	712-0411	Hex Lock Nut 5/16-24	28.	710-1652	Hex Washer Screw 1/4-20
10.	736-0247	Flat Washer .406 x 1/1/4	29.	726-0272	Clamp
11.	736-0217	Lock Washer 3/8	30.	710-0382	Hex Cap Screw 1/2-13 x 5.0
12.	710-1273	Hex Cap Screw 3/8-24 x 2.75	31.	712-0421	Knob 5/16-18
13.	723-0438	Rubber Seal	32.	725-3166	Switch
14.	710-0604A	Hex Washer Screw 5/16-18	33.	731-1613	Safety Switch Mounting Cover
15.	712-0384	Hex Lock Nut 1/2-13	34.	710-1268	Hex Washer Screw
16.	781-0627	Chipper Blade Cover	35.	725-1700	Switch Cover
17.	712-3004A	Hex Flange Lock Nut 5/16-18	36.	710-1260A	Screw 5/16-18 x .750
18.	681-0098	Inner Flail Housing Assembly	37.	723-0400	Safety Glasses (Not Shown)

# Model 203

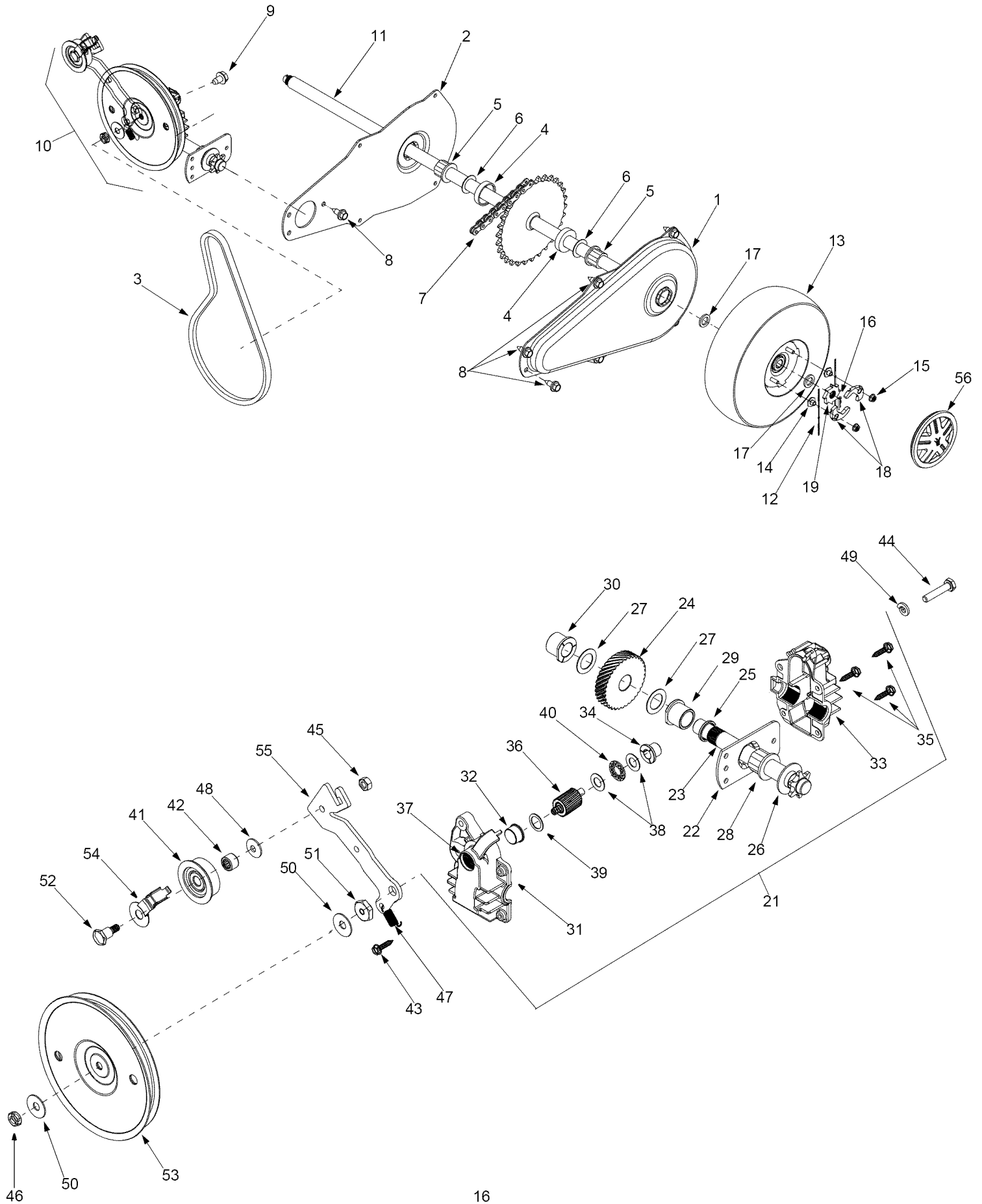



## Model 203

Ref. No.	Part No.	Part Description	Ref. No.	Part No.	Part Description
1.	781-0677	Chain Case LH	29.	741-0414	Flange Bearing .629 ID
2.	781-0676	Chain Case RH	30.	741-0415	Flange Bearing .566 ID
3.	754-0457	V-Belt	31.	719-0325	Lower Housing
4.	748-0313	Spacer	32.	748-0373	Flange Bearing .503 ID
5.	741-0413	Hex Flange Bearing	33.	719-0324A	Upper Housing
6.	736-0336	Flat Washer	34.	748-0208A	Flange Bearing .378 ID
7.	713-0422	Chain	35.	710-0589	Hex Washer Screw #10-16 x .75
8.	710-1652	Self Tapp. Screw 1/4-20	36.	717-1433	Pinion Shaft 10T
9.	710-0603	Hex Washer Screw 5/16	37.	721-0329	Oil Seal
10.	618-0256	Chipper Shredder Trans. Assembly	38.	736-0314	Thrust Washer .382 ID x .684 OD
11.	611-0063	Axle Shaft Assembly	39.	736-0520	Flat Washer .504 ID x .70 OD
12.	10622B	Plastic Spring Ratchet	40.	741-0479	Thrust Bearing .375 ID x .812 OD
13.	634-0243	Wheel Complete 10 x 4 x 4	41.	656-0008	Idler Pulley Assy. w/ Bearing
14.	712-0456	Hex Nut 1/4-20	42.	741-0556	Needle Bearing .375 ID x .375 OD
15.	712-3027	Hex Flanged Lock Nut 1/4-20	43.	710-0589	Hex Screw #10-16 x .75
16.	714-0104	Cotter Pin	44.	710-1062	Hex Cap Screw 1/4-20 x 1.25
17.	736-0366	Flat Washer 5/8 ID x 1.0 OD	45.	712-0138	Hex Nut 1/4-28
18.	748-0188B	Pawl LH .345 ID	46.	712-3045	Hex Jam Nut 5/16-24 LH Thd
	748-0381	Pawl RH .345 ID (Not Shown)	47.	732-0357A	Extension Spring 1.12 Lg
19.	748-0405	Wheel Ratchet 1.62 OD x .5 serr	48.	736-0270	Bell Washer .265 ID x .75 OD
21.	618-0255	6T Shredder Transmission Assy.	49.	736-0329	Lock Washer 1/4
22.	16500A	Hex Bearing Cup	50.	736-0425	Bell Washer .325 ID x .930 OD
23.	711-1118	6T Sprocket Output Shaft	51.	738-0440	Shoulder Spacer .375 ID x .165 OD
24.	717-1432	Helical 34T Gear	52.	738-0826	Shoulder Bolt 1/4-28 x .375
25.	721-0213	Oil Seal	53.	756-0656	Flat Pulley 5.06 Dia
26.	736-0187	Flat Washer .64 ID x 1.24 OD	54.	782-7569	Belt Keeper
27.	736-0336	Flat Washer 5/8 x 1.0	55.	682-0054	Idler Bracket Assembly
28.	741-0413	Hex Flange Bearing .631 ID	56.	731-1825	Hub Cap

**IMPORTANT: For a proper working machine, use Factory Approved Parts.**

**V-BELTS are especially designed to engage and disengage safely. A substitute (non OEM) V-Belt can be dangerous by not disengaging completely.**

# Model 203

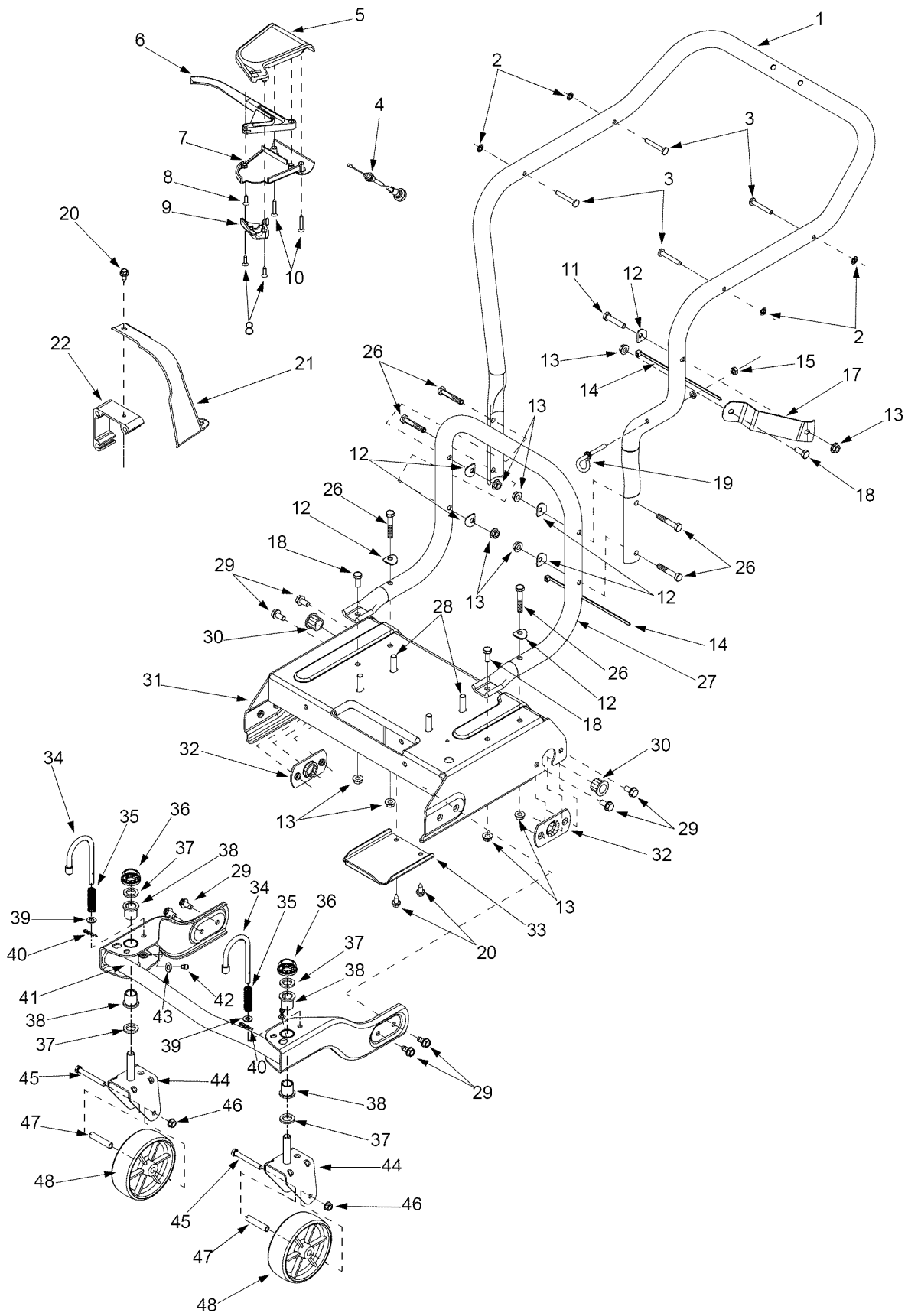

## Model 203

Ref. No.	Part No.	Part Description	Ref. No.	Part No.	Part Description
1.	749-1095	Upper Handle	27.	749-1094	Push Lower Handle
2.	1539-019	Push Nut	28.	710-0502A	Screw 3/8-16 x 1.25
3.	711-0737	Stud Pin .250 x 1.75	29.	710-0604A	Hex Washer Screw 5/16-18 x .625
4.	746-0714	Clutch Cable 56"	30.	741-0413	Hex Flange Bearing .631 x .720
5.	731-1735	Upper Clutch Cover	31.	681-0097A	Frame Assembly
6.	731-0620	Drive Lever	32.	781-0700	Axle Bracket
7.	731-1736	Lower Clutch Cover	33.	781-0697	Transmission Cover
8.	710-0841	Screw #10-12 x .750	34.	747-0924	Lock Pin
9.	731-1059	Cable Mounting Cap	35.	732-0306	Compression Spring
10.	710-1331	Screw #10-16 x 1.25	36.	726-0214	Push Cap
11.	710-0805	Hex Cap Screw 5/16-18 x 1.50	37.	736-0366	Flat Washer 5/8 ID x 1.0 OD
12.	736-0451	Shoulder Washer .320 ID x .93 OD	38.	741-0487A	Flange Bearing .632 ID
13.	712-3004A	Hex Flange Lock Nut 5/16-18	39.	736-0264	Flat Washer .330 ID x .630 OD
14.	725-0157	Cable Tie	40.	714-0104	Cotter Pin
15.	712-0380	Hex Nut 1/4-28	41.	681-0087	Bracket Assembly
17.	781-0647	Discharge Chute Bracket	42.	737-3000	Grease Fitting 3/16
18.	710-3008	Hex Cap Screw 5/16-18 x .75	43.	736-0931	Flat Washer.203 ID x .403 OD
19.	747-0815	Eye Bolt	44.	681-0088	Bracket Assembly
20.	710-1652	Self Tapp. Screw 1/4-20 x .625	45.	710-0521	Hex Cap Screw 3/8-16 x 3.0
21.	731-1646	Belt Cover	46.	712-0431	Flange Lock Nut 3/8-16
22.	719-0359	Engine Mounting Adapter	47.	750-1042	Spacer
26.	710-3103	Hex Cap Screw 5/16-18 x 1.75	48.	734-1804	Wheel 6.0 x 2.0

**NOTE:** For **painted parts**, please refer to the list of color codes below. Please add the applicable color code, wherever needed, to the part number to order a replacement part. For instance, if a part numbered 700-xxxx is painted Yard-Man Green, the part number to order would be 700-xxxx-0665.

Yard-Man Green: 0665  
 Yard-Man Yellow: 0674  
 Powder Black: 0637

# MANUFACTURER'S LIMITED WARRANTY FOR:



The limited warranty set forth below is given by MTD LLC with respect to new merchandise purchased and used in the United States, its possessions and territories.

"MTD" warrants this product against defects in material and workmanship for a period of two (2) years commencing on the date of original purchase and will, at its option, repair or replace, free of charge, any part found to be defective in materials or workmanship. This limited warranty shall only apply if this product has been operated and maintained in accordance with the Operator's Manual furnished with the product, and has not been subject to misuse, abuse, commercial use, neglect, accident, improper maintenance, alteration, vandalism, theft, fire, water, or damage because of other peril or natural disaster. Damage resulting from the installation or use of any part, accessory or attachment not approved by MTD for use with the product(s) covered by this manual will void your warranty as to any resulting damage.

Normal wear parts or components thereof are subject to separate terms as follows: All normal wear parts or component failures will be covered on the product for a period of 90 days regardless of cause. After 90 days, but within the two year period, normal wear part failures will be covered ONLY IF caused by defects in materials or workmanship of OTHER component parts. Normal wear parts and components include, but are not limited to: batteries, belts, blades, blade adapters, grass bags, rider deck wheels, seats, snow thrower skid shoes, shave plates, auger spiral rubber, and tires.

**HOW TO OBTAIN SERVICE:** Warranty service is available, WITH PROOF OF PURCHASE, through your local authorized service dealer. To locate the dealer in your area, check your Yellow Pages, or contact MTD LLC at P.O. Box 361131, Cleveland, Ohio 44136-0019, or call 1-800-800-7310 or log on to our Web site at [www.mtdproducts.com](http://www.mtdproducts.com).

This limited warranty does not provide coverage in the following cases:

- a. The engine or component parts thereof. These items may carry a separate manufacturer's warranty. Refer to applicable manufacturer's warranty for terms and conditions.
- b. Log splitter pumps, valves, and cylinders have a separate one year warranty.
- c. Routine maintenance items such as lubricants, filters, blade sharpening, tune-ups, brake adjustments, clutch adjustments, deck adjustments, and normal deterioration of the exterior finish due to use or exposure.

- d. MTD does not extend any warranty for products sold or exported outside of the United States, its possessions and territories, except those sold through MTD's authorized channels of export distribution.
- e. Replacement parts that are not genuine MTD parts.
- f. Service completed by someone other than an authorized service dealer.
- g. Transportation charges and service calls.

**No implied warranty, including any implied warranty of merchantability of fitness for a particular purpose, applies after the applicable period of express written warranty above as to the parts as identified. No other express warranty, whether written or oral, except as mentioned above, given by any person or entity, including a dealer or retailer, with respect to any product, shall bind MTD. During the period of the warranty, the exclusive remedy is repair or replacement of the product as set forth above.**

**The provisions as set forth in this warranty provide the sole and exclusive remedy arising from the sale. MTD shall not be liable for incidental or consequential loss or damage including, without limitation, expenses incurred for substitute or replacement lawn care services or for rental expenses to temporarily replace a warranted product.**

Some states do not allow the exclusion or limitation of incidental or consequential damages, or limitations on how long an implied warranty lasts, so the above exclusions or limitations may not apply to you.

In no event shall recovery of any kind be greater than the amount of the purchase price of the product sold. **Alteration of safety features of the product shall void this warranty.** You assume the risk and liability for loss, damage, or injury to you and your property and/or to others and their property arising out of the misuse or inability to use the product.

This limited warranty shall not extend to anyone other than the original purchaser or to the person for whom it was purchased as a gift.

**HOW STATE LAW RELATES TO THIS WARRANTY:** This limited warranty gives you specific legal rights, and you may also have other rights which vary from state to state.

**IMPORTANT:** Owner must present Original Proof of Purchase to obtain warranty coverage.

**MTD LLC, P.O. BOX 361131 CLEVELAND, OHIO 44136-0019; Phone: 1-800-800-7310**