

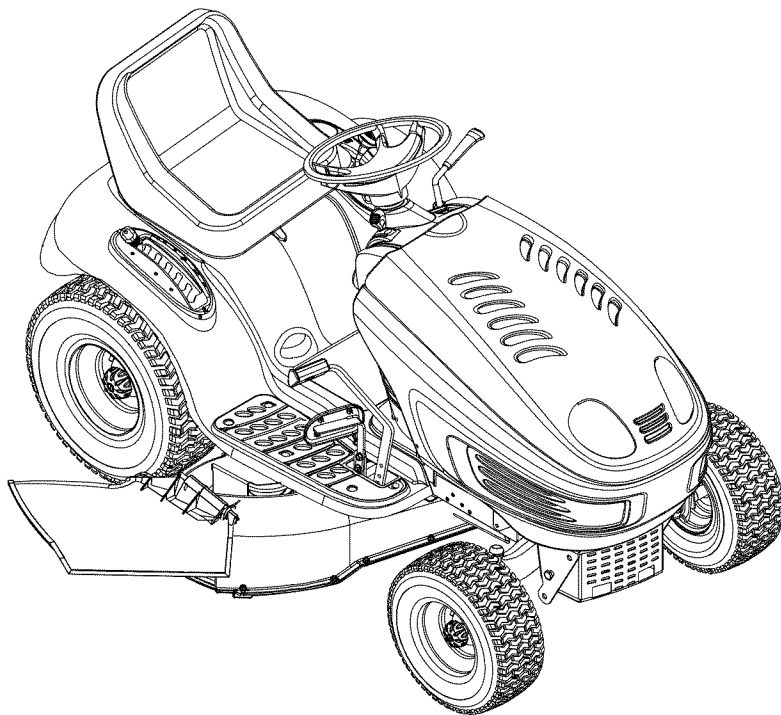

Operator's Manual



Auto Drive Lawn Tractors Models 604G & 604H

IMPORTANT: Read safety rules and instructions carefully before operating equipment.

Warning: This unit is equipped with an internal combustion engine and should not be used on or near any unimproved forest-covered, brush-covered or grass-covered land unless the engine's exhaust system is equipped with a spark arrester meeting applicable local or state laws (if any). If a spark arrester is used, it should be maintained in effective working order by the operator. In the State of California the above is required by law (Section 4442 of the California Public Resources Code). Other states may have similar laws. Federal laws apply on federal lands. A spark arrester for the muffler is available through your nearest engine authorized service dealer or contact the service department, P.O. Box 361131 Cleveland, Ohio 44136-0019.

MTD LLC, P.O. BOX 361131 CLEVELAND, OHIO 44136-0019

PRINTED IN U.S.A.

FORM NO. 770-10448D
(11/2003)

TABLE OF CONTENTS

Content	Page	Content	Page
Customer Support	2	Maintenance	17
Important Safe Operation Practices	3	Attachments & Accessories	24
Tractor Set-Up	7	Illustrated Parts List	26
Operation	9	Warranty	Back Cover
Making Adjustments	15		

FINDING MODEL NUMBER

This Operator's Manual is an important part of your new lawn tractor. It will help you assemble, prepare and maintain the unit for best performance. Please read and understand what it says.



Before you start assembling your new equipment, please locate the model plate under the seat of the tractor and copy the information in the space provided below. A sample model plate is also given below. This information will be necessary to use the manufacturer's web site and/or help from the Customer Support Department or an authorized service dealer.

(Model Number) (Serial Number)

www.yardman.com

MTD LLC
P. O. BOX 361131
CLEVELAND, OH 44136
330-220-4683
800-800-7310

Copy the model number here: _____

Copy the serial number here: _____

CUSTOMER SUPPORT

Please do NOT return the unit to the retailer from where it was purchased, without first contacting Customer Support.

If you have difficulty assembling this product or have any questions regarding the controls, operation or maintenance of this unit, you can seek help from the experts. Choose from the options below:

	<p>Visit yardman.com for many useful suggestions. Click on Customer Support button and you will get the four options reproduced here. Click on the appropriate button and help is immediately available.</p> <div style="display: flex; justify-content: space-between; align-items: center; margin-top: 20px;"> <div style="width: 30%; text-align: center;"> <p><i>The answer you are looking for could be just a mouse click away!</i></p> </div> <div style="width: 30%; border: 1px solid gray; padding: 5px;"> <div style="border-bottom: 1px solid gray; padding: 2px;"> <p style="font-size: x-small; margin: 0;">Find Answers</p> <p style="font-size: x-small; margin: 0;">Click here to search our knowledge base. Search by product, keyword, or phrase.</p> </div> <div style="border-bottom: 1px solid gray; padding: 2px;"> <p style="font-size: x-small; margin: 0;">My Stuff</p> <p style="font-size: x-small; margin: 0;">Login to check the status of your questions, modify your inquiries, or update your personal profile.</p> </div> <div style="border-bottom: 1px solid gray; padding: 2px;"> <p style="font-size: x-small; margin: 0;">Service Locator</p> <p style="font-size: x-small; margin: 0;">Need local assistance? Click here to find authorized service centers in your area.</p> </div> <div style="padding: 2px;"> <p style="font-size: x-small; margin: 0;">Manuals Online</p> <p style="font-size: x-small; margin: 0;">Need a manual and/or parts list? Download literature from recent model years.</p> </div> </div> <div style="width: 30%; text-align: center;"> <p><i>The answer you are looking for could be just a mouse click away!</i></p> </div> </div>
	<p>To reach the Customer Support Line, please call 1-800-800-7310.</p>
	<p>The engine manufacturer is responsible for all engine-related issues with regards to performance, power-rating, specifications, warranty and service. Please refer to the engine manufacturer's Owner's/Operator's Manual, at the end of this manual, for more information.</p>

SECTION 1: IMPORTANT SAFE OPERATION PRACTICES



WARNING: This symbol points out important safety instructions which, if not followed, could endanger the personal safety and/or property of yourself and others. Read and follow all instructions in this manual before attempting to operate this machine. Failure to comply with these instructions may result in personal injury. When you see this symbol—heed its warning.

DANGER: This machine was built to be operated according to the rules for safe operation in this manual. As with any type of power equipment, carelessness or error on the part of the operator can result in serious injury. This machine is capable of amputating hands and feet and throwing objects. Failure to observe the following safety instructions could result in serious injury or death.

California Proposition 65 Warning: Engine exhaust, some of its constituents, and certain vehicle components contain or emit chemicals known to the State of California to cause cancer and birth defects or other reproductive harm.

General Operation

1. Read, understand, and follow all instructions on the machine and in the manual(s) before attempting to assemble and operate. Keep this manual in a safe place for future and regular reference and for ordering replacement parts.
2. Be familiar with all controls and their proper operation. Know how to stop the machine and disengage them quickly.
3. Never allow children under 14 years old to operate this machine. Children 14 years old and over should read and understand the operation instructions and safety rules in this manual and should be trained and supervised by a parent.
4. Never allow adults to operate this machine without proper instruction.
5. To help avoid blade contact or a thrown object injury, keep bystanders, helpers, children and pets at least 75 feet from the machine while it is in operation. Stop machine if anyone enters the area.
6. Thoroughly inspect the area where the equipment is to be used. Remove all stones, sticks, wire, bones, toys, and other foreign objects which could be picked up and thrown by the blade(s). Thrown objects can cause serious personal injury.
7. Plan your mowing pattern to avoid discharge of material toward roads, sidewalks, bystanders and the like. Also, avoid discharging material against a wall or obstruction which may cause discharged material to ricochet back toward the operator.
8. Always wear safety glasses or safety goggles during operation and while performing an adjustment or repair to protect your eyes. Thrown objects which ricochet can cause serious injury to the eyes.
9. Wear sturdy, rough-soled work shoes and close-fitting slacks and shirts. Loose fitting clothes and jewelry can be caught in movable parts. Never operate this machine in bare feet or sandals.
10. Be aware of the mower and attachment discharge direction and do not point it at anyone. Do not operate the mower without the discharge cover or entire grass catcher in its proper place.
11. Do not put hands or feet near rotating parts or under the cutting deck. Contact with the blade(s) can amputate hands and feet.
12. A missing or damaged discharge cover can cause blade contact or thrown object injuries.
13. Stop the blade(s) when crossing gravel drives, walks, or roads and while not cutting grass.
14. Watch for traffic when operating near or crossing roadways. This machine is not intended for use on any public roadway.
15. Do not operate the machine while under the influence of alcohol or drugs.
16. Mow only in daylight or good artificial light.
17. Never carry passengers.
18. Disengage blade(s) before shifting into reverse. Back up slowly. Always look down and behind before and while backing to avoid a back-over accident.
19. Slow down before turning. Operate the machine smoothly. Avoid erratic operation and excessive speed.
20. Disengage blade(s), set parking brake, stop engine and wait until the blade(s) come to a complete stop before removing grass catcher, emptying grass, unclogging chute, removing any grass or debris, or making any adjustments.
21. Never leave a running machine unattended. Always turn off blade(s), place transmission in neutral, set parking brake, stop engine and remove key before dismounting.
22. Use extra care when loading or unloading the machine into a trailer or truck. This unit should not be driven up or down ramp(s), because the unit could tip over, causing serious personal injury. The unit must be pushed manually on ramp(s) to load or unload properly.
23. Muffler and engine become hot and can cause a burn. Do not touch.
24. Check overhead clearances carefully before driving under low hanging tree branches, wires, door openings etc., where the operator may be struck or pulled from the unit, which could result in serious injury.
25. Disengage all attachment clutches, depress the brake pedal completely and shift into neutral before attempting to start engine.
26. Your machine is designed to cut normal residential grass of a height no more than 10". Do not attempt to mow through unusually tall, dry grass (e.g., pasture) or piles of dry leaves. Dry grass or leaves may contact the engine exhaust and/or build up on the mower deck presenting a potential fire hazard.

27. Use only accessories and attachments approved for this machine by the machine manufacturer. Read, understand and follow all instructions provided with the approved accessory or attachment.
28. Data indicates that operators, age 60 years and above, are involved in a large percentage of riding mower-related injuries. These operators should evaluate their ability to operate the riding mower safely enough to protect themselves and others from serious injury.
29. If situations occur which are not covered in this manual, use care and good judgment. Call the Customer Support Line for assistance.

Slope Operation

Slopes are a major factor related to loss of control and tip-over accidents which can result in severe injury or death. All slopes require extra caution. If you cannot back up the slope or if you feel uneasy on it, do not mow it.

For your safety, use the slope gauge included as part of this manual to measure slopes before operating this unit on a sloped or hilly area. If the slope is greater than 15 degrees as shown on the slope gauge, do not operate this unit on that area or serious injury could result.

Do:

1. Mow up and down slopes, not across. Exercise extreme caution when changing direction on slopes.
2. Watch for holes, ruts, bumps, rocks, or other hidden objects. Uneven terrain could overturn the machine. Tall grass can hide obstacles.
3. Use slow speed. Choose a low enough speed setting so that you will not have to stop or shift while on the slope. Tires may lose traction on slopes even though the brakes are functioning properly. Always keep machine in gear when going down slopes to take advantage of engine braking action.
4. Follow the manufacturer's recommendations for wheel weights or counterweights to improve stability.
5. Use extra care with grass catchers or other attachments. These can change the stability of the machine.
6. Keep all movement on the slopes slow and gradual. Do not make sudden changes in speed or direction. Rapid engagement or braking could cause the front of the machine to lift and rapidly flip over backwards which could cause serious injury.
7. Avoid starting or stopping on a slope. If tires lose traction, disengage the blade(s) and proceed slowly straight down the slope.

Do Not:

1. Do not turn on slopes unless necessary; then, turn slowly and gradually downhill, if possible.
2. Do not mow near drop-offs, ditches or embankments. The mower could suddenly turn over if a wheel is over the edge of a cliff, ditch, or if an edge caves in.
3. Do not try to stabilize the machine by putting your foot on the ground.
4. Do not use a grass catcher on steep slopes.
5. Do not mow on wet grass. Reduced traction could cause sliding.
6. Do not shift to neutral and coast downhill. Over-speeding may cause the operator to lose control of the machine resulting in serious injury or death.

7. Do not tow heavy pull behind attachments (e.g. loaded dump cart, lawn roller, etc.) on slopes greater than 5 degrees. When going down hill, the extra weight tends to push the tractor and may cause you to lose control. (e.g. tractor may speed up, braking and steering ability are reduced, attachment may jack-knife and cause tractor to overturn).

Children

1. Tragic accidents can occur if the operator is not alert to the presence of children. Children are often attracted to the machine and the mowing activity. They do not understand the dangers. Never assume that children will remain where you last saw them.
 - a. Keep children out of the mowing area and in watchful care of a responsible adult other than the operator.
 - b. Be alert and turn machine off if a child enters the area.
 - c. Before and while backing, look behind and down for small children.
 - d. Never carry children, even with the blade(s) shut off. They may fall off and be seriously injured or interfere with safe machine operation.
 - e. Use extreme care when approaching blind corners, doorways, shrubs, trees or other objects that may block your vision of a child who may run into the machine.
 - f. Disengage the cutting blade(s) before shifting in reverse. The "No-Cut-In Reverse" feature is a reminder not to cut in reverse and to help avoid back over accidents. Do not defeat it.
 - g. Keep children away from hot or running engines. They can suffer burns from a hot muffler.
 - h. Remove key when machine is unattended to prevent unauthorized operation.
2. Never allow children under 14 years old to operate the machine. Children 14 years old and over should read and understand the operation instructions and safety rules in this manual and should be trained and supervised by a parent.

Towing

1. Tow only with a machine that has a hitch designed for towing. Do not attach towed equipment except at the hitch point.
2. Follow the manufacturer's recommendation for weight limits for towed equipment and towing on slopes.
3. Never allow children or others in or on towed equipment.
4. On slopes, the weight of the towed equipment may cause loss of traction and loss of control.
5. Travel slowly and allow extra distance to stop.
6. Do not shift to neutral and coast downhill.

Service

Gasoline:

1. **To avoid personal injury or property damage** use extreme care in handling gasoline. **Gasoline is** extremely flammable and the vapors are explosive. Serious personal injury can occur when gasoline is spilled on yourself or your clothes which can ignite. Wash your skin and change clothes immediately.
 - a. Use only an approved gasoline container.

- b. Never fill containers inside a vehicle or on a truck or trailer bed with a plastic liner. Always place containers on the ground away from your vehicle before filling.
- c. When practical, remove gas-powered equipment from the truck or trailer and refuel it on the ground. If this is not possible, then refuel such equipment on a trailer with a portable container, rather than from a gasoline dispenser nozzle.
- d. Keep the nozzle in contact with the rim of the fuel tank or container opening at all times until fueling is complete. Do not use a nozzle lock-open device.
- e. Extinguish all cigarettes, cigars, pipes and other sources of ignition.
- f. Never fuel machine indoors.
- g. Never remove gas cap or add fuel while the engine is hot or running. Allow engine to cool at least two minutes before refueling.
- h. Never over fill fuel tank. Fill tank to no more than ½ inch below bottom of filler neck to allow space for fuel expansion.
- i. Replace gasoline cap and tighten securely.
- j. If gasoline is spilled, wipe it off the engine and equipment. Move unit to another area. Wait 5 minutes before starting the engine.
- k. To reduce fire hazards, keep machine free of grass, leaves, or other debris build-up. Clean up oil or fuel spillage and remove any fuel soaked debris.
- l. Never store the machine or fuel container inside where there is an open flame, spark or pilot light as on a water heater, space heater, furnace, clothes dryer or other gas appliances.
- m. Allow a machine to cool at least 5 minutes before storing.

General:

- 1. Never run an engine indoors or in a poorly ventilated area. Engine exhaust contains carbon monoxide, an odorless, and deadly gas.
- 2. Before cleaning, repairing, or inspecting, make certain the blade(s) and all moving parts have stopped. Disconnect the spark plug wire and ground against the engine to prevent unintended starting.
- 3. Periodically check to make sure the blades come to complete stop within approximately (5) five seconds after operating the blade disengagement control. If the blades do not stop within the this time frame, your unit should be

- serviced professionally by your *Troy-Bilt* dealer.
- 4. Check brake operation frequently as it is subjected to wear during normal operation. Adjust and service as required.
- 5. Check the blade(s) and engine mounting bolts at frequent intervals for proper tightness. Also, visually inspect blade(s) for damage (e.g., excessive wear, bent, cracked).
Replace the blade(s) with the original equipment manufacturer's (O.E.M.) blade(s) only, listed in this manual. "Use of parts which do not meet the original equipment specifications may lead to improper performance and compromise safety!"
- 6. Mower blades are sharp. Wrap the blade or wear gloves, and use extra caution when servicing them.
- 7. Keep all nuts, bolts, and screws tight to be sure the equipment is in safe working condition.
- 8. Never tamper with the safety interlock system or other safety devices. Check their proper operation regularly.
- 9. After striking a foreign object, stop the engine, disconnect the spark plug wire(s) and ground against the engine. Thoroughly inspect the machine for any damage. Repair the damage before starting and operating.
- 10. Never attempt to make adjustments or repairs to the machine while the engine is running.
- 11. Grass catcher components and the discharge cover are subject to wear and damage which could expose moving parts or allow objects to be thrown.
For safety protection, frequently check components and replace immediately with original equipment manufacturer's (O.E.M.) parts only, listed in this manual. "Use of parts which do not meet the original equipment specifications may lead to improper performance and compromise safety!"
- 12. Do not change the engine governor settings or over-speed the engine. The governor controls the maximum safe operating speed of the engine.
- 13. Maintain or replace safety and instruction labels, as necessary.
- 14. Observe proper disposal laws and regulations for gas, oil, etc. to protect the environment.

Your Responsibility

Restrict the use of this power machine to persons who read, understand and follow the warnings and instructions in this manual and on the machine.

SECTION 2: SLOPE GAUGE

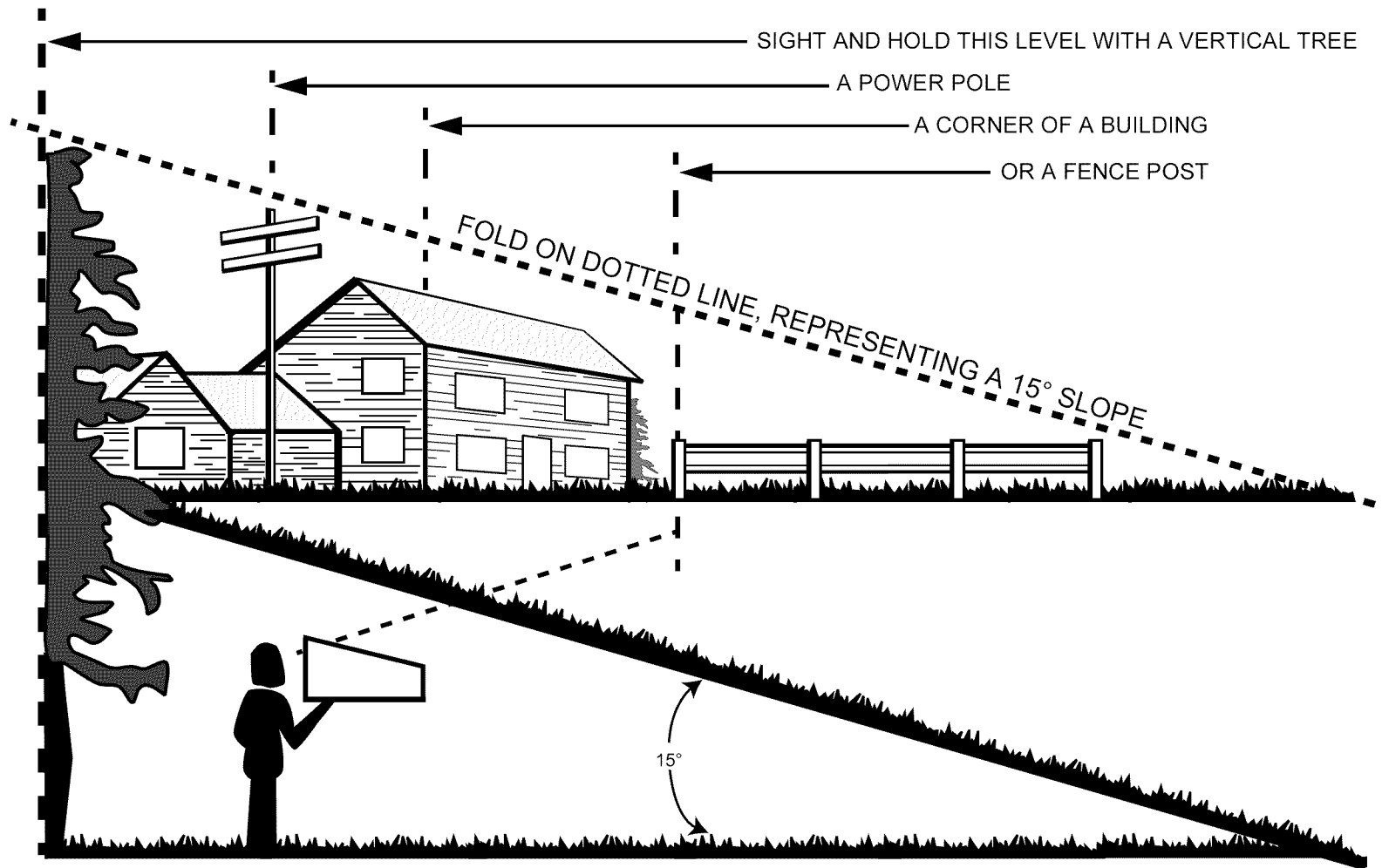

WARNING

Do not mow on inclines with a slope in excess of 15 degrees (a rise of approximately 2-1/2 feet every 10 feet). A riding mower could overturn and cause serious injury. If operating a walk-behind mower on such a slope, it is extremely difficult to maintain your footing and you could slip, resulting in serious injury. Operate RIDING mowers up and down slopes, never across the face of slopes.

SECTION 3: TRACTOR SET-UP

NOTE: This manual covers specifications of two models. Please follow instructions and parts numbers pertaining to your tractor only.

Attaching the Battery Cables

NOTE: If these cables are already attached, proceed to “Attaching Steering Wheel.”

IMPORTANT: The positive battery terminal is marked Pos. (+). The negative battery terminal is marked Neg. (-).

1. The positive cable (heavy red wire) is secured to the positive battery terminal (+) with a hex bolt and hex nut at the factory. Make certain that the rubber boot covers the terminal to help protect it from corrosion.
2. Remove the hex bolt and wing nut from the negative cable. See Figure 1.
3. Remove the black plastic cover, if present, from the negative battery terminal and attach the negative cable (heavy black wire) to the negative battery terminal (-) with the bolt and wing nut.
4. Make certain the hold-down strap is in position over the battery, securing it in place.

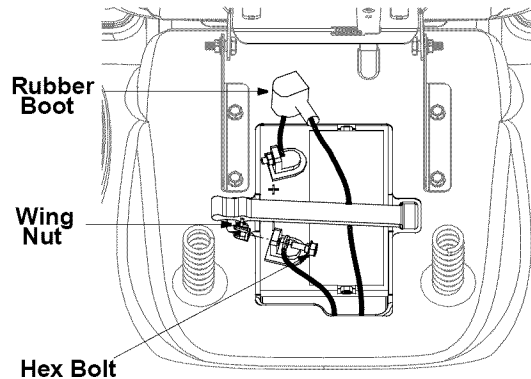

Figure 1

NOTE: If the battery is put into service after the date shown on top of battery, charge the battery as instructed on page 18 of this manual prior to operating the tractor.

Attaching The Steering Wheel

1. The hardware for attaching the steering wheel has been packed within the steering wheel, beneath steering wheel cap. Carefully pry off the steering wheel cap and remove the hardware.
2. With the wheels of the tractor pointing straight forward, place the steering wheel over the steering shaft. Place the washer (with the cupped side down) over the steering shaft and secure with the hex bolt. See Figure 2.
3. Place the steering wheel cap over the center of the steering wheel and push downward until it “clicks” into place.

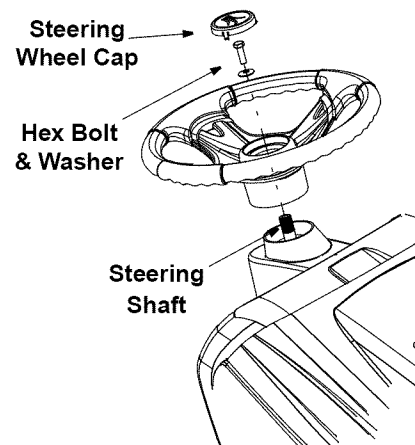

Figure 2

Attaching The Seat

NOTE: For shipping reasons, seats are either fastened to the tractor seat's pivot bracket with a plastic tie, or mounted backward to the pivot bracket. In either case, free the seat from its shipping position and remove the two knobs from the bottom of seat before proceeding with instructions below.

- If your seat was shipped mounted backwards on the seat pivot bracket, pull out the tab found on the seat stop and hold it open while sliding the seat off the seat pivot bracket. See Figure 3.
1. Position the shoulder screws (found on the base of the seat) inside the slot openings in the seat pivot bracket. See Figure 3.

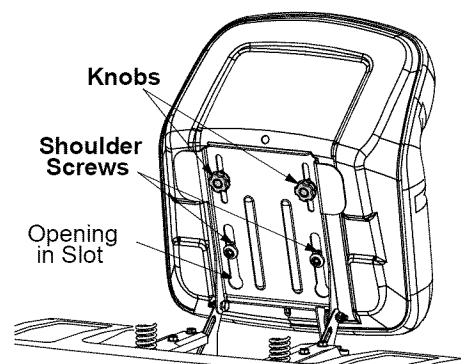

Figure 3



WARNING: Before operating this machine, make sure the seat is engaged in the seat stop, stand behind the machine and pull back on seat until fully engaged into stop.

2. Slide the seat slightly rearward in the seat pivot bracket, lining up the rear slots in the pivot bracket with the remaining two holes in the seat's base.
3. Select desired position for the seat, and secure with the two knobs removed earlier. See Figure 3.

Gas and Oil Fill-Up

The gasoline tank is located under the hood and depending on the model of tractor, has a capacity of either two or three gallons. Do not overfill.



WARNING: Use extreme care when handling gasoline. Gasoline is extremely flammable and the vapors are explosive. Never fuel machine indoors or while the engine is hot or running. Extinguish cigarettes, cigars, pipes, and other sources of ignition.

IMPORTANT: Even if the tractor is shipped with motor oil in the engine, you **must** check the engine oil level before operating. The capacity of the engine's sump and oil filter is 62 oz (1.8 liters). Be careful not to overfill.

Remove Shipping Brace

IMPORTANT: The shipping brace must be removed and discarded before operating your riding mower.



WARNING: Make sure the riding mower's engine is off, ignition key removed, and the parking brake engaged before proceeding further.

1. Locate the shipping brace and accompanying warning tag on the right side of the mower, between discharge chute and cutting deck. See Figure 4.
2. While holding the discharge chute up, rotate the shipping brace clockwise and remove.
3. Discard the shipping brace.



WARNING: The mowing deck is capable of throwing objects. Failure to operate the riding mower without the discharge cover in the proper operating position could result in serious personal injury and/or property damage.

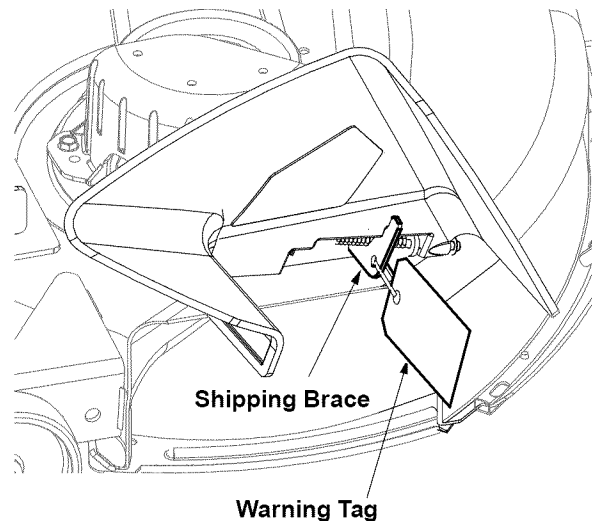

Figure 4

SECTION 4: OPERATION

Know the Controls

Read this owner's manual and safety rules before operating your lawn tractor. Compare figure below with your lawn tractor to learn about the location and purpose of various controls and adjustments. Save this manual for future reference. It is very important to follow the instructions and operate the controls properly.

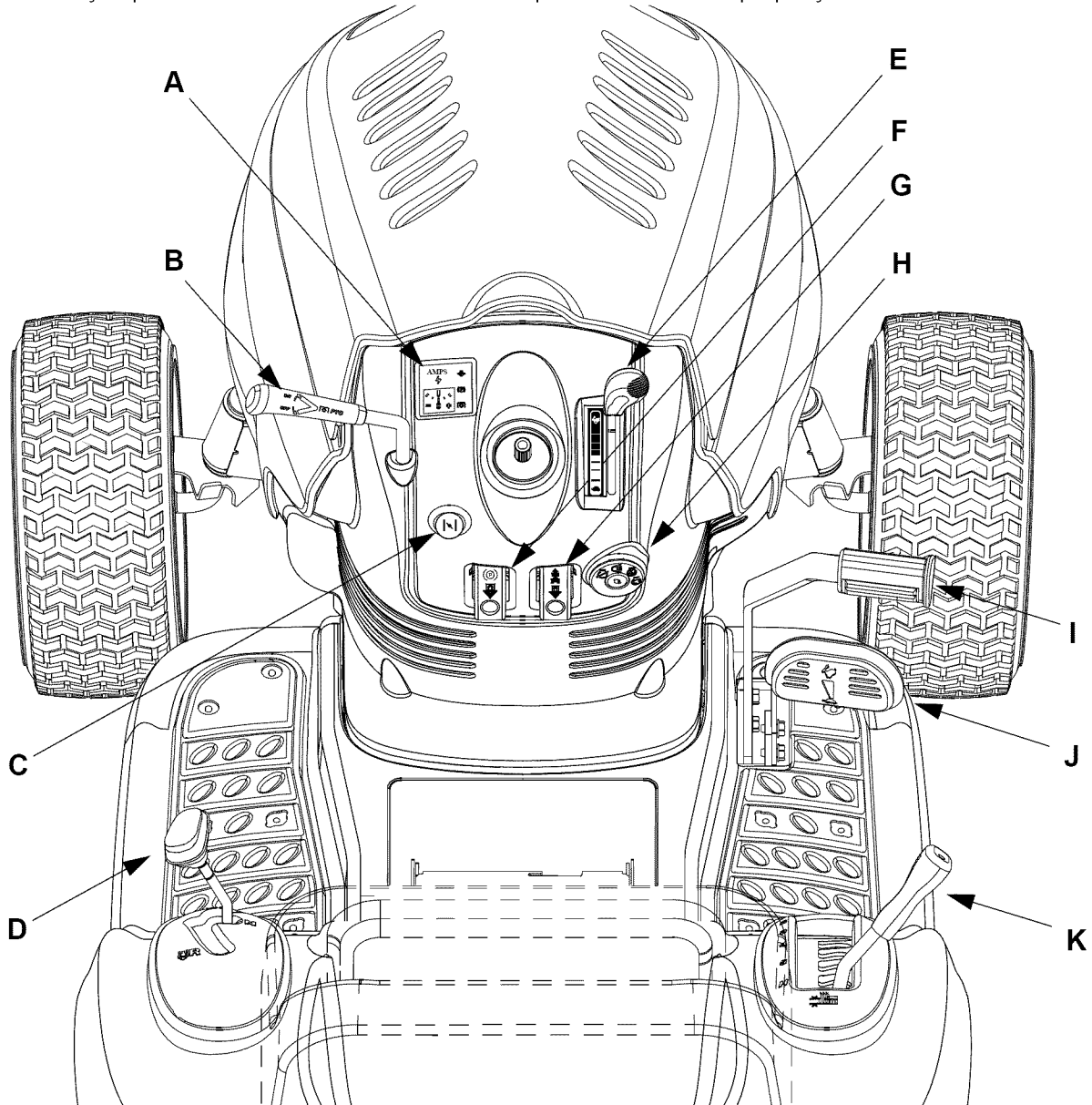

Figure 5

- | | |
|--|--------------------------------|
| A Systems Indicator Monitor/Ammeter | G Cruise Control Button |
| B PTO (Power Take-off) Lever | H Ignition Switch |
| C Choke Control | I Brake Pedal |
| D Shift Lever | J Drive Pedal |
| E Throttle Control Lever | K Deck Lift Lever |
| F Parking Brake Button | |

NOTE: Any reference in this manual to the RIGHT or LEFT side of the tractor is observed from operator's position.

Throttle Control Lever

The throttle control lever controls the speed of the engine. When set in a given position, the throttle will maintain a uniform engine speed.

IMPORTANT: When operating the tractor with the cutting deck engaged, throttle control lever must **always be** in the FAST (rabbit) position.

Choke Control

The choke control can be found on the left side of the dash panel and is activated by pulling the knob outward. Activating the choke control closes the choke plate on the carburetor and aids in starting the engine.

Brake Pedal

The brake pedal is used for sudden stops or setting the parking brake. This pedal must be fully depressed to activate the safety interlock switch when starting the tractor.

Parking Brake Button

NOTE: The parking brake must be set if the operator leaves the seat with the engine running; otherwise the engine will automatically shut off.

- To set the parking brake, fully depress the brake pedal and push the parking brake button in. Hold the button in while taking your foot off the brake pedal. Both parking button and brake pedal will stay depressed.
- To release the parking brake, depress the brake pedal slightly. The parking brake button will then return to its original position.

IMPORTANT: Always set the parking brake when leaving the tractor unattended.

Drive Pedal

The drive pedal controls movement and ground speed of the tractor. Depress the drive pedal with your right foot (when the tractor shift lever is in either forward or reverse) to cause the tractor to move. The further down the pedal is depressed, the faster the tractor will travel. The pedal will return to its original position when it is not depressed.

PTO (Blade Engage) Lever

Engaging the PTO (Blade Engage) lever transfers power to the cutting deck or other (separately available) attachments. The PTO lever **must** be disengaged (Blade Stop) when (1) starting the engine, (2) traveling in reverse or (3) if the operator leaves the seat.

To engage the PTO (Blade Engage), proceed as follows:

1. Move the throttle control lever to the FAST (rabbit) position.
2. Grasp the PTO (Blade Engage) lever and pivot it all the way forward into the engaged (ON) position.
3. Keep the throttle lever in the FAST (rabbit) position for the most efficient use of the cutting deck or other (separately available) attachments.

To disengage the PTO (Blade Engage), proceed as follows:

1. Move the PTO (Blade Engage) lever to the Blade Stop position. This will cut off power to deck or other attachments.
- The engine will automatically shut off if:
 - (i) the operator leaves the seat while the PTO (Blade Engage) is still engaged regardless of whether the parking brake is engaged, and
 - (ii) the PTO (Blade Engage) is engaged while the drive pedal is in position for reverse travel.

Ignition Switch

Ignition switch is activated to start the engine. Insert key into the ignition switch and turn clockwise to the START position. Release the key into the ON position once engine has fired.

WARNING: Never leave a running machine unattended. Always disengage PTO, move shift lever into neutral position, set parking brake, stop engine and remove key to prevent unintended starting.

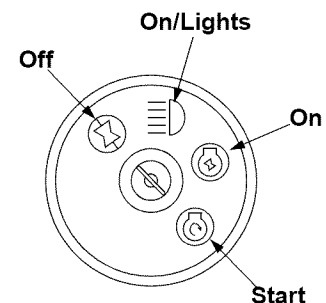
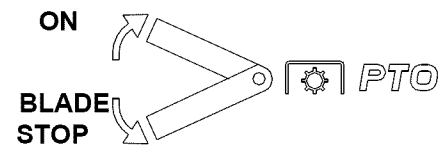
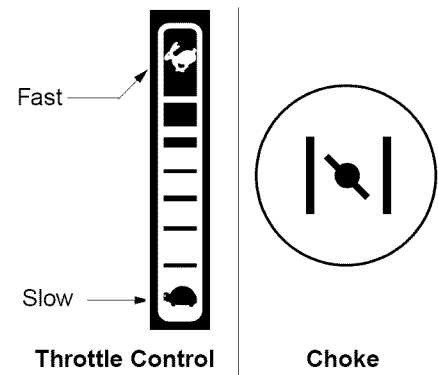

Headlights

- To turn on the headlights, rotate the same ignition key from ON position to ON/LIGHTS position of the ignition switch.
- To turn off the headlights, rotate the ignition key from ON/LIGHTS position to either ON position (to leave the engine running) or OFF position (to shut the engine off).



WARNING: Never move the key into the Start position while the engine is running. Doing so may cause damage to your engine's starter.

Systems Indicator Monitor / Hour Meter

Your tractor is equipped with four indicator lights and an ammeter as shown in the figure here.

If the brake light or PTO light illuminates when attempting to start the unit, proceed as follows:

Indication	Remedy
Brake light on	Depress the brake pedal.
PTO light on	Move PTO lever to "Blade Stop" position.

It is normal for the oil light and the battery light to illuminate while the engine is cranking, but if either illuminates while the **engine is running**, follow the steps below as per indication:

Indication	Remedy
Oil light on	Stop the tractor immediately and check the crankcase oil level as instructed in the <i>engine</i> manual. Add oil as required.

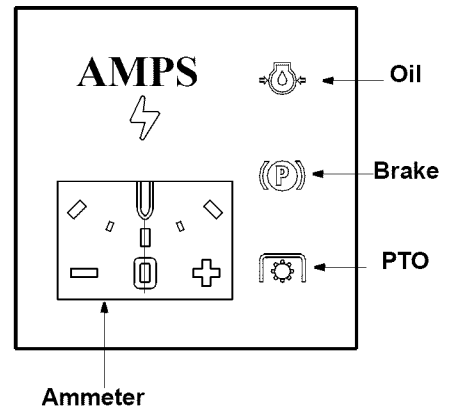

Ammeter

The ammeter measures the electrical output of the engine's charging system. Under normal operating conditions, with engine at full throttle, the ammeter should indicate positive charge.

Shift Lever

The shift lever has three positions: FORWARD (F), NEUTRAL (N) and REVERSE (R). These control the direction of movement of the tractor. Depress the brake pedal and let the tractor stop before moving the shift lever to one of these three positions.

IMPORTANT: Never force the shift lever. Doing so may result in serious damage to the tractor's transmission.

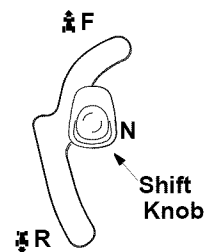

Cruise Control Button

The cruise control feature should only be utilized while traveling in the forward direction. To engage the cruise control, follow these steps:

1. Place shift lever in FORWARD position, then slowly depress the drive pedal until desired speed is achieved.
2. Lightly depress the cruise control button.
3. While continuing to hold the cruise button in, lift your foot from the drive pedal (you should feel the cruise latch engage).
4. Once engaged, the cruise control button and the drive pedal will lock in the "down" position, and the tractor will maintain same forward speed.

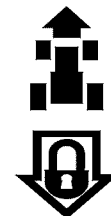

NOTE: Cruise control cannot be engaged at the tractor's fastest ground speed. If the operator should attempt to do so, the tractor will automatically decelerate to the fastest optimal mowing ground speed.

- To disengage the cruise control, lightly depress either the brake pedal or the drive pedal.

- To change to the reverse direction when operating with cruise control, depress the brake pedal to disengage the cruise control and bring the tractor to a complete stop. Then place the shift lever in the REVERSE position and depress the drive pedal.

Seat Adjustment Lever

To adjust the seat forward or backward, loosen the two seat adjustment knobs and reposition the seat to the desired position. Once a comfortable position is found, tighten the adjustment knobs to lock the seat in place.

Deck Lift Lever

The deck lift lever is used to change the height of the cutting deck. To use, move the lever to the left, then place it in one of the six notches best suited for your application.

To set the cutting height of the deck you will also have to adjust the deck wheels so that they are between ¼-inch and ½-inch above the ground when the tractor is on a smooth, flat surface such as a driveway. refer to Deck Levelling instructions on page 15.

NOTE: *The deck wheels are an anti-scalp feature of the deck and are not designed to support the weight of the cutting deck.*

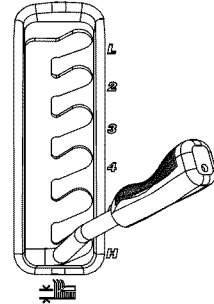

Cup Holder (if equipped)

The tractor's cup holder is located on the fender to the left of the seat, just to the rear of the parking brake lever.

Safety Interlock Switches

The safety interlock system prevents the engine from cranking or starting unless the parking brake is engaged, and the PTO lever is disengaged. If this system should ever malfunction, do not operate the tractor, immediately contact a service dealer.

- The safety interlock system will automatically shut off the engine if the operator leaves the seat before engaging the parking brake.
- The safety interlock system will automatically shut off the engine if the operator leaves the tractor's seat with the PTO (Blade Engage) lever engaged, regardless of whether the parking brake is engaged.
- The safety interlock system will automatically shut off the engine if the PTO (Blade Engage) lever is moved into the engaged (ON) position with the drive pedal in position for reverse travel.

CAUTION: Tampering with or attempting to bypass the Safety Interlock Switches in any way will void your tractor's warranty. Do not operate the tractor if the interlock system is malfunctioning.

Starting the Engine

NOTE: Refer to the **TRACTOR SET-UP** on page 7 manual for gasoline and oil fill-up instructions.

1. Insert the tractor key into the ignition switch.
2. Disengage the PTO (Blade Engage) lever.
3. Engage the tractor's parking brake.
4. Pull the Choke Control knob outward.
5. Turn the ignition key clockwise to the START position. After the engine starts, release the key. It will return to the ON position.

IMPORTANT: Do **not** hold the key in the START position for longer than ten seconds at a time. Doing so may cause damage to your engine's electric starter.

6. After the engine starts, move the throttle control lever to the FAST position and Choke Control knob inward.

NOTE: Do **not** leave choke control on while operating the tractor. Doing so will result in a "rich" fuel mixture and cause the engine to run poorly.

Stopping the Engine

WARNING: If you strike a foreign object, stop the engine, disconnect the spark plug wire(s) and ground against the engine. Thoroughly inspect the machine for any damage. Repair damage before restarting.

1. If the blades are engaged, disengage the PTO.
2. Turn the ignition key counterclockwise to the OFF position.
3. Remove the key from the ignition switch to prevent unintended starting.

Driving The Tractor

- Depress the brake pedal to release the parking brake.
- Move the throttle lever into the FAST (rabbit) position.
- To move forward, place the shift lever in the FORWARD position, then slowly depress the drive pedal until the desired speed is achieved. To move in reverse, place the shift lever in the REVERSE position, check that the area behind is clear, then slowly depress the drive pedal.

Driving On Slopes

IMPORTANT: Refer to the **SLOPE GAUGE** on page 6 to help determine slopes where you may operate the tractor safely.

- Mow up and down slopes, **never** across.
- Watch for holes, ruts, bumps, rocks, or other hidden objects. Uneven terrain could overturn the machine. Tall grass can hide obstacles.
- Avoid turns when driving on a slope. If a turn must be made, attempt while going downward on the slope.
- Avoid stopping when driving up a slope. If it is necessary to stop while driving up a slope, start up smoothly and carefully to reduce the possibility of flipping the tractor over backward.

Mowing

The following information will be helpful when using the cutting deck with your tractor.

- Do not mow at high ground speed, especially if a mulch kit or grass collector is installed.

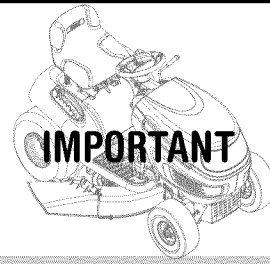

Do not leave the seat of the tractor without

1. disengaging PTO (Blade Engage) lever
2. depressing brake pedal
3. engaging parking brake

If leaving the tractor unattended, also turn the ignition key off and remove the key.

Do not use the shift lever to change the direction of travel when the tractor is in motion. Always use the brake pedal to bring the tractor to a complete stop before moving the shift lever.

Avoid sudden starts, excessive speed and sudden stops while driving the tractor.

Do not mow on slope in excess of 15 degrees (a rise of approximately 2-1/2 feet every 10 feet).

Keep hands and feet away from the opening of the cutting deck.

Plan your mowing pattern to avoid discharge of materials toward roads, sidewalks, bystanders and the like. Also, avoid discharging material against a wall or obstruction which may cause discharged material to ricochet back toward the operator.

- For best results it is recommended that the first two laps be cut with the discharge thrown towards the center. After the first two laps, reverse the direction to throw the discharge to the outside for the balance of cutting. This will give a better appearance to the lawn.
- Do not cut the grass too short. Short grass invites weed growth and yellows quickly in dry weather.
- Mowing should always be done with the engine at full throttle.
- Under heavier conditions it may be necessary to go back over the cut area a second time to get a clean cut.
- Do not attempt to mow heavy brush and weeds and extremely tall grass. Your tractor is designed to mow lawns, not clear brush.
- Keep the blades sharp and replace the blades when worn. Refer to **Cutting Blades** on page 19 of this manual for proper blade sharpening instructions.



WARNING: To help avoid blade contact or a thrown object injury, keep bystanders, helpers, children and pets at least 75 feet from the machine while it is in operation. Stop machine if anyone enters the area.

Mulching

Some models are equipped with a mulch kit with special blades to recirculate the grass clippings into the lawn where they act as a natural fertilizer.

- On models with 46-inch decks, where the mulch kit is packed separately within the tractor's crate, follow the instructions included with the mulch kit.

Observe the following points for best results when mulching.

- Never attempt to mulch if the lawn is damp. Wet grass tends to stick to the underside of the cutting deck preventing proper mulching of the clippings.
- Do not attempt to mulch more than 1/3 the total height of the grass or approximately 1-1/2 inches. Doing so will cause the clippings to clump up beneath the deck and not be mulched effectively.
- Maintain a slow ground speed to allow the grass clippings more time to effectively be mulched.
- Always position the throttle control lever in the FAST (rabbit) position and allow it to remain there while mowing. Failing to keep the engine at full throttle places strain on the tractor's engine and does not allow the blades to properly mulch grass.

NOTE: *It is not necessary to remove the discharge chute to operate the mower with the mulch kit installed.*

- To operate the cutting deck without mulching, on models so equipped, simply remove the mulch plug by unthreading the plastic wing nut which fastens it to the cutting deck. See Figure 6. This will allow the clippings to discharge through the side opening.

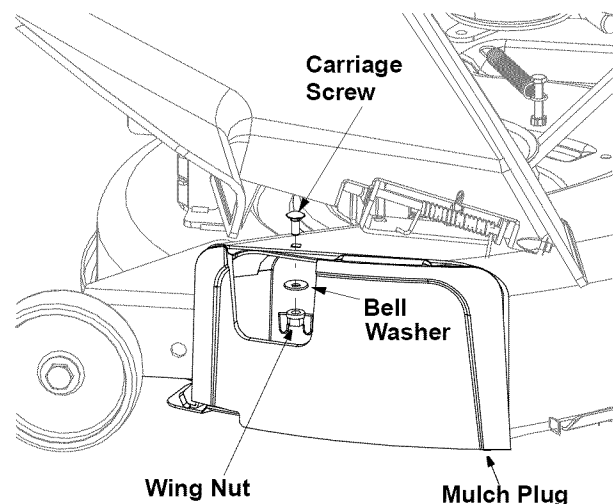

Figure 6

SECTION 5: MAKING ADJUSTMENTS



WARNING: Never attempt to make any adjustments while the engine is running, except where specified in the operator's manual. Disconnect spark plug wire(s) and ground against the engine before performing any adjustments, repairs or maintenance.

Seat



WARNING: Before operating this machine, make sure the seat is engaged in the seat stop, stand behind the machine and pull back on seat until fully engaged into stop.

1. Flip the seat up as shown in Figure 7.
2. Loosen the two seat adjustment knobs located under the seat. See Figure 7.
3. Slide the seat forward or rearward, then tighten the knobs to lock the seat at the desired position.
4. Put the seat down to the operating position.

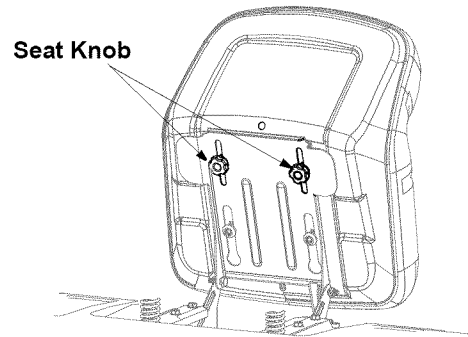

Figure 7

Steering

- If the tractor turns tighter in one direction than the other, or if the ball joints are being replaced due to damage or wear, the steering drag links may need to be adjusted. Adjust the drag links so that equal lengths are threaded into the ball joints on both sides.
1. Loosen the jam nut on the drag link at the rear of the ball joint. See Figure 8.
 2. Remove the hex nut and lock washer on top of the ball joint. See Figure 8.
 3. Thread the ball joint **toward** the jam nut to shorten the drag link.
 4. Thread the ball joint **away** from the jam nut to lengthen the drag link.
 5. Replace hex nut and lock washer and retighten the jam nut after proper adjustment is achieved.

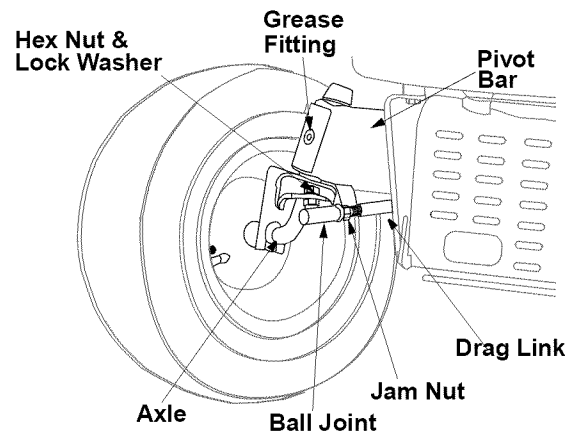

Figure 8

NOTE: Threading the ball joints too far on to the drag links will cause the front tires to "toe-in" too far. Proper toe-in is between 1/16" and 5/16".

Front tire toe-in can be measured as follows:

1. Place the steering wheel in position for straight ahead travel.
2. In front of the axle, measure the distance horizontally from the inside of the left rim to the inside of the right rim. Note the distance.
3. Behind the axle, measure the distance horizontally from inside of the left rim to the inside of the right rim. Note the distance.
4. The measurement taken in front of the axle should be between 1/16" and 5/16" less than the measurement taken behind the axle. Adjust if necessary.

Leveling the Deck

NOTE: Check the tractor's tire pressure before performing any deck leveling adjustments. Refer to Tires later in this section for further information regarding tire pressure.

Front To Rear

The front of the cutting deck is supported by a stabilizer bar that can be adjusted to level the deck from front to rear. The front of the deck should be between 1/4-inch and 3/8-inch lower than the rear of the deck. Adjust if necessary:

1. With the tractor parked on a firm, level surface, place the deck lift lever in the top notch (highest position) and rotate the blade nearest the discharge chute so that it is parallel with the tractor.
2. Measure the distance from the front of the blade tip to the ground and the rear of the blade tip to the ground. The first measurement taken should be between 1/4" and 3/8" less than the second measurement. Determine the approximate distance necessary for proper adjustment and proceed, if necessary, to the next step.
3. Locate the two lock nuts on the opposite side of the stabilizer bracket. See Figure 9. Tighten the lock nuts to raise the front of the deck; loosen the lock nuts to lower the front of the deck.

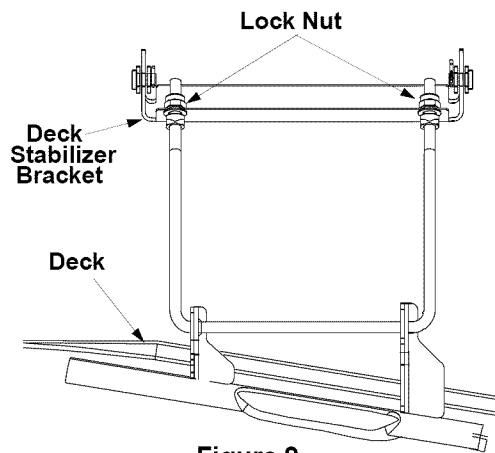

Figure 9

Side to Side

If the cutting deck appears to be mowing unevenly, a side to side adjustment can be performed. Adjust if necessary as follows:

1. With the tractor parked on a firm, level surface, place the deck lift lever in the top notch (highest position) and rotate both blades so that they are perpendicular with the tractor.
2. Measure the distance from the outside of the left blade tip to the ground and the distance from the outside of the right blade tip to the ground. Both measurements taken should be equal. If they're not, proceed to the next step.
3. Loosen, but do **not** remove, the hex cap screw on the left deck hanger bracket. See Figure 10.
4. To balance the deck turn the adjustment gear, located immediately behind the hex cap screw, clockwise/up or counterclockwise/down. See Figure 10. You will need an adjustable wrench for this step.
5. The deck is properly balanced when both blade tip measurements, taken earlier, are equal.
6. Retighten the hex cap screw on the left deck hanger bracket when proper adjustment is achieved.

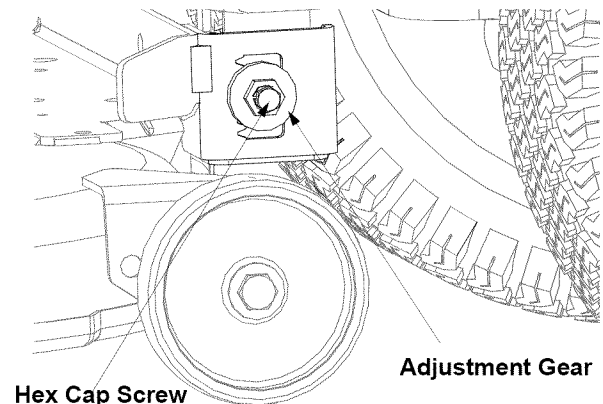

Figure 10

Parking Brake Adjustment



WARNING: Never attempt to adjust the brakes while the engine is running. Always disengage PTO, move shift lever into neutral position, stop engine and remove key to prevent unintended starting.

If the tractor does not come to a complete stop when the brake pedal is completely depressed, or if the tractor's rear wheels can roll with the parking brake applied, the brake is in need of adjustment. The brake disc can be found on the right side of the transmission in the rear of the tractor. Adjust if necessary as follows:

1. Looking at the transmission from the right side of the tractor, locate the compression spring and brake disc. See Figure 11.
2. Loosen, but do **not** remove, the hex nut found on the right side of the brake assembly. See Figure 11.
3. Using a feeler gauge, set the gap between the brake disc and the brake puck at .011".
4. Re-tighten the hex nut loosened earlier.

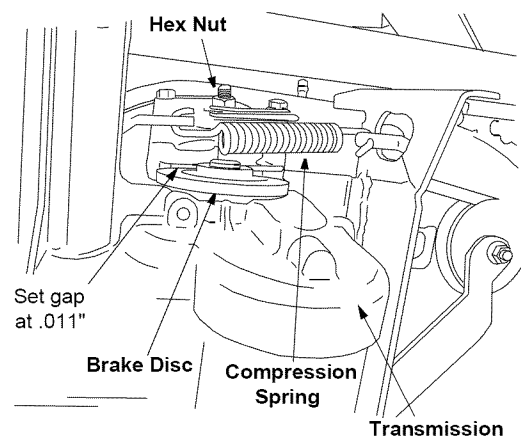

NOTE: View shown from beneath tractor.

Figure 11

SECTION 6: MAINTAINING YOUR LAWN TRACTOR



WARNING: Before performing any maintenance or repairs, disengage PTO, move shift lever into neutral position, set parking brake, stop engine and remove key to prevent unintended starting.

Engine

Refer to the *engine manual* for engine maintenance instructions.

- Check engine oil level before each use as instructed in the *engine manual*. Read and follow instructions carefully. Refer to this manual for details about type and grade of oil.

Changing Engine Oil

1. Unscrew oil fill cap and remove dipstick from the oil fill tube. See Figure 12.
2. Pop open the protective cap on the end of the oil drain valve to expose the oil drain port. See Figure 12.
3. Push the oil drain hose (packed with this manual) onto the oil drain port. Route the opposite end of the hose into an appropriate oil collection container with a capacity great enough to collect the used oil (approximately 62 oz.).
4. Push the oil drain valve in slightly, then rotate counterclockwise and pull outward to begin draining oil. See Figure 12.
5. Service the **oil filter** as instructed in the *engine manual*.
6. Perform the above steps in the opposite order after oil has finished draining. Refill the engine with approximately 62 oz. (1.8 liters) of new motor oil.

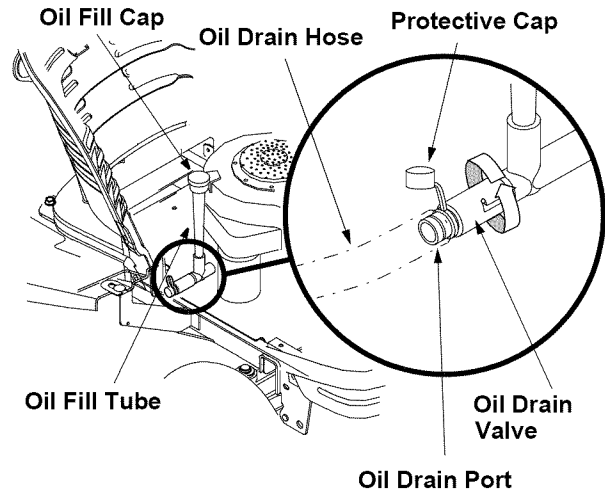

Figure 12

Air Cleaner

Service the pre-cleaner, if so equipped, and cartridge as instructed in the *engine manual* at the end of this manual.

Spark Plug

Clean the spark plug and reset its gap once a season, preferably at the start of each mowing season. Refer to the *engine manual* for correct plug type and gap specifications.

Lubrication

Engine

- Lubricate the engine with motor oil as instructed in the *engine manual*.

Pivot Points & Linkage

- Lubricate all pivot points on the drive system, parking brake and lift linkage at least once a season with light oil.

Rear Wheels

- Remove rear wheels from the axles once a season; lubricate the axles and rims with an all-purpose automotive grease and re-install the wheels

Front Wheels

- Each front wheel axle is equipped with a grease fitting; lubricate with a grease gun after every 25 hours of tractor operation or at least once a season.

Cleaning The Engine & Deck

- Wipe off any fuel or oil spillage on the machine promptly. Do not allow grass, leaves, and dirt to accumulate around the cooling fins or on any other part of the machine, especially the pulleys and other moving parts.

IMPORTANT: The use of a pressure washer or garden hose to clean your tractor is NOT recommended. It may cause damage to electrical components, spindles, pulleys, bearings or the engine. The use of water will reduce life of the

tractor and/or its serviceability.



WARNING: Before servicing, repairing, or inspecting, always disengage PTO, move shift lever into neutral position, set parking brake, stop engine and remove key from tractor to prevent unintended starting.

Tire Pressure

IMPORTANT: Never exceed the maximum inflation pressure shown on the sidewall of the tire.

- The recommended operating tire pressure is approximately 10 psi for the rear tires and 14 psi for the front tires. Refer to the tire sidewall for exact tire manufacturer’s recommended or maximum psi. Do not overinflate. Uneven tire pressure could cause the cutting deck to mow unevenly.

Battery

The battery is sealed and maintenance-free. Acid levels cannot be checked. However, some care is required for long battery life:

- Always keep the battery cables and terminals clean and free of corrosive build-up.
- After cleaning the battery and terminals, apply a light coat of petroleum jelly or grease to both terminals
- Always keep the rubber boot positioned over the positive terminal to prevent shorting.

IMPORTANT: If removing the battery, disconnect the **negative** (black) wire from its terminal first, followed by the **positive** (red) wire. When re-installing the battery, always connect the positive (red) wire to its terminal first, followed by **negative** (black) wire.

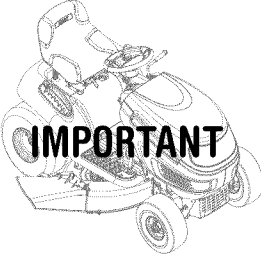

IMPORTANT

1. Battery wires must be connected to the correct terminals. Reversing them could change the polarity and damage engine’s alternating system.
2. Do not jump-start a damaged battery.
3. When storing the battery, disconnect the negative terminal and store with full charge.

Charging

- If the tractor has not been used for an extended period of time, use a voltmeter or load tester to measure the charge. The voltmeter should read 12.6 V or higher for adequate charge. Otherwise, charge the battery with an automotive-type 12-volt charger for a minimum of one hour at six amps. Follow the chart below to charge:

Voltmeter Reading	State of Charge (percentage)	Charging Time (minutes)
12.7	100	0
12.4	75	90
12.2	50	180
12	25	280



WARNING: Batteries give off an explosive gas while charging. Charge the battery in a well ventilated area and keep away from an open flame or pilot light as on a water heater, space heater, furnace, clothes dryer or other gas appliances.

Jump-Starting

IMPORTANT: Do not jump-start a damaged battery. Before connecting the jumper cables, make sure that the two equipment are not in contact and their ignitions are turned off. Follow the sequence described below very closely.

1. Connect the positive (+) lead of the jumper cable to the positive (+) post of the discharged battery.
2. Connect the other end of the positive (+) jumper cable to the positive (+) post of the good battery.
3. Connect one end of the negative (-) jumper cable to the negative (-) post of the good battery.

4. Connect the other end of the negative (-) cable to the engine block of the stalled tractor, **away** from the battery, and stand back.
5. Start the stalled tractor and leave it running to charge the battery.
6. Disconnect the negative (-) jumper cable from the tractor.
7. Disconnect the other end of the negative (-) jumper cable from the negative (-) post of the good battery.
8. Disconnect the positive (+) jumper cable from the positive (+) post of the good battery.
9. Disconnect the other end of the positive (+) jumper cable from the formerly dead battery.

Fuse

Two fuses are installed in your tractor's wiring harness to protect the tractor's electrical system from damage caused by excessive amperage.

- If the electrical system does not function, or your tractor's engine will not crank, first check to be certain that one of the fuses has not blown. One can be found under the hood mounted behind the top of the dash panel on the support bar. The other fuse is mounted to the inside of the frame, behind the battery. Pull each fuse out to determine if it is good or blown.

IMPORTANT: Always use a fuse with the same amperage capacity for replacement.

Cutting Deck Removal

The cutting deck will have to be removed from the tractor for a variety of service tasks. To remove the cutting deck, proceed as follows:

1. Place the PTO lever in the disengaged (OFF) position and engage the parking brake.
2. Lower the deck by moving the deck lift lever into the bottom notch on the right fender.
3. Remove the PTO belt from around the engine pulley and from around the PTO idler pulley(s).
4. Looking at the cutting deck from the left side of the tractor, locate the deck support pin on the rear left side of the deck. See Figure 13.
5. Pull the deck support pin outward to release the deck from the deck lift arm.
6. Rotate the pin slightly toward the rear of the tractor and release the pin into the hole provided.
7. Repeat the above steps on the right side of the tractor.
8. Move the deck lift lever into the top notch on the right fender to raise the deck lift arms out of the way.
9. Gently slide the cutting deck toward the front of the tractor allowing the hooks on the deck to release themselves from the deck stabilizer rod. Do **not** let the deck fall to the ground.

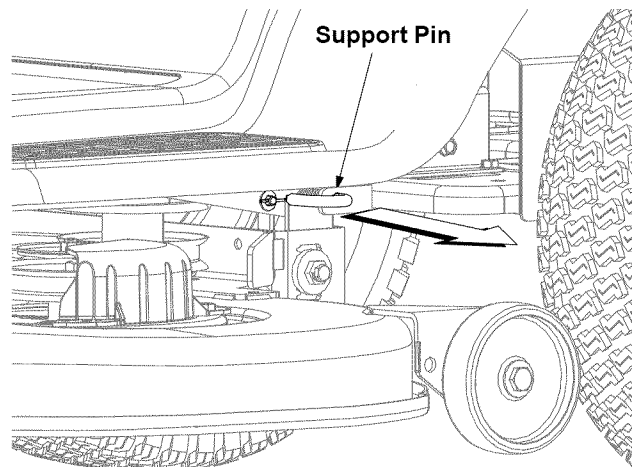

Figure 13

Cutting Blades



WARNING: Shut tractor engine off, remove ignition key, disconnect the spark plug wire(s) and ground against the engine before proceeding with job. Protect your hands by using heavy gloves or a rag to grasp the cutting blade

- Periodically inspect the blade adapter and/or spindle for cracks or damage, especially if you strike a foreign object. Replace immediately if damaged. Remove the blades following instructions below:
 1. Remove the deck from beneath the tractor, then gently flip the deck over to expose its underside.
 2. Place a block of wood between the center deck housing baffle and the cutting blade to act as a stabilizer. See Figure 14.
 3. Use a 15/16" wrench, remove the hex flange nut that secures the blade to the spindle assembly. See Figure 14.
 4. To properly sharpen the cutting blades, remove equal amounts of metal from both ends of the blades along the cutting edges, parallel to the trailing edge, at a 25° to 30° angle. See Figure 14.
- If the cutting edge of the blade has already been sharpened to within 5/8" of the wind wing radius, or if any metal separation is present, replace the blades with new ones. See Figure 14.

IMPORTANT: Each cutting blade edge has to be ground equally to maintain proper blade balance. A poorly balanced blade will cause excessive vibration, may damage the tractor and/or result in personal injury.

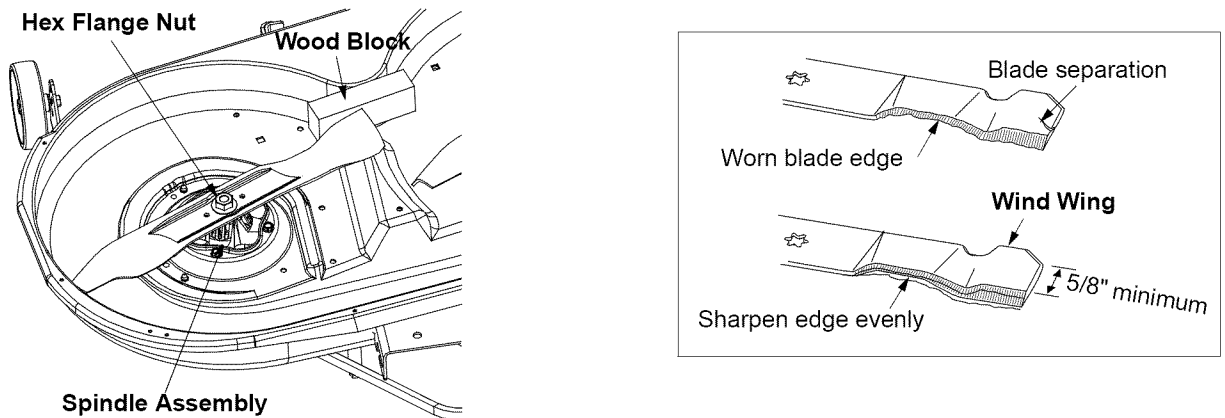

Figure 14

5. Test the blade by balancing it on a round shaft screwdriver. Grind metal from the heavy side until it balances evenly.
6. When replacing the blade, be sure to install the blade with the side of the blade marked “Bottom” (or with a part number stamped in it) facing the ground when the mower is in the operating position.
7. Use a torque wrench to tighten the blade spindle hex flange nut to between 70 and 90 foot-pounds.
8. Gently slide the cutting deck (from the right side) out from underneath the tractor.

Changing Transmission Drive Belt

NOTE: It is recommended that both drive belts be replaced at the same time.

1. Remove the cutting deck as instructed earlier in this section.
2. After disconnecting the battery cables, remove the battery and battery tray from beneath the seat.

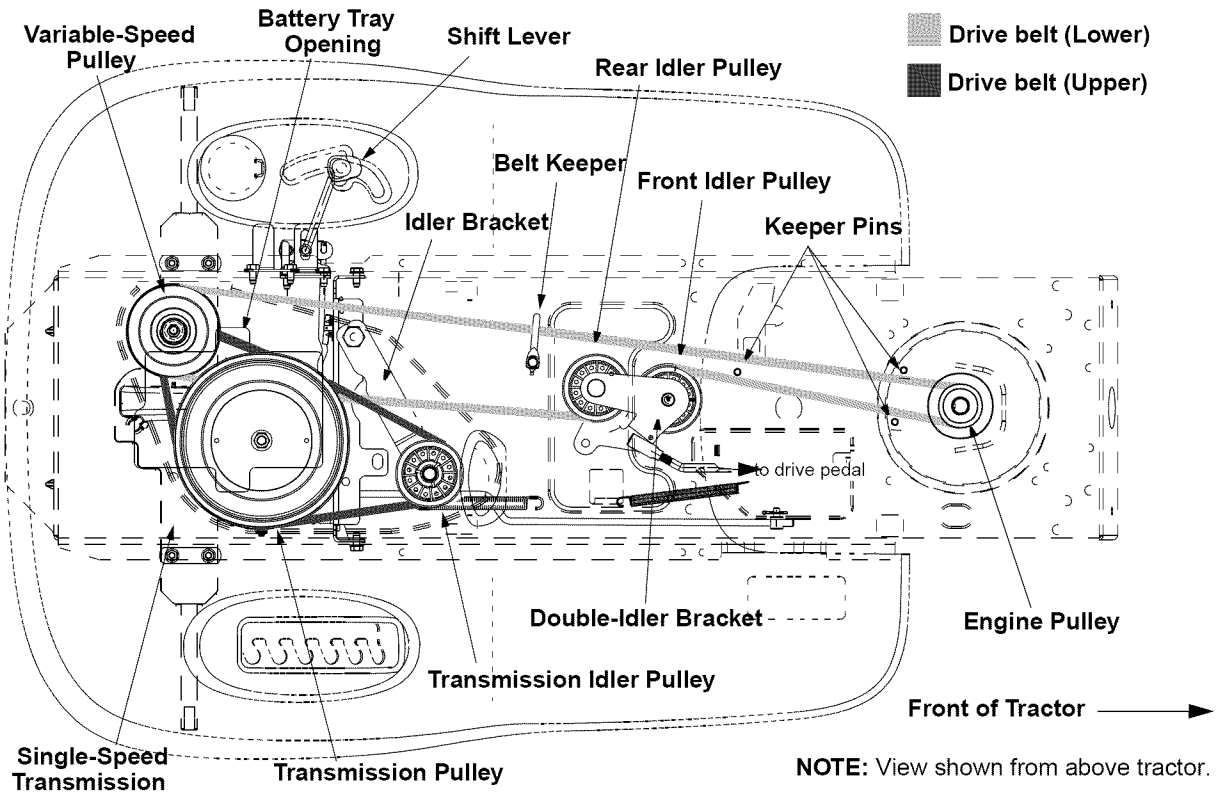

Figure 15

IMPORTANT: When removing the battery, disconnect the **NEGATIVE** (Black) wire from its terminal first, followed by the **POSITIVE** (Red) wire. Re-install in reverse order.

Upper Drive Belt

1. Locate the transmission idler pulley on the upper drive belt by looking through the battery tray opening. See Figure 15.
2. Grasp the bracket and pivot the transmission idler pulley toward the rear of the tractor to release tension on the upper drive belt.
3. Remove the belt from around the transmission idler pulley.
4. Remove the upper drive belt from around the transmission pulley and the variable-speed pulley. Slowly rotate the pulley counterclockwise to roll the belt off it.
5. Remove the upper drive belt by pulling it up through the battery tray opening.
6. Reroute the new upper drive belt as shown in Figure 15.

Lower Drive Belt

IMPORTANT: Note the routing of the lower drive belt around both the pulleys and the belt keepers **before** performing the following steps.

1. Locate the variable-speed pulley through the battery tray opening. See Figure 15.
2. Remove the variable-speed pulley by loosening the hex bolt that secures it to the transmission. Use a second wrench to hold the hex nut on the bottom side of the pulley.
3. Slide the belt off the variable-speed pulley as you lift the pulley up and out through the battery tray opening.
4. Remove the rear idler pulley from the double-idler bracket while unrouting the belt from around both the rear and the front idler pulley. See Figure 15.
5. Remove the hex bolt from the center of the engine pulley and gently lower it off the engine crankshaft. Be careful not to lose any washers or spacers which may be on top of the engine pulley.

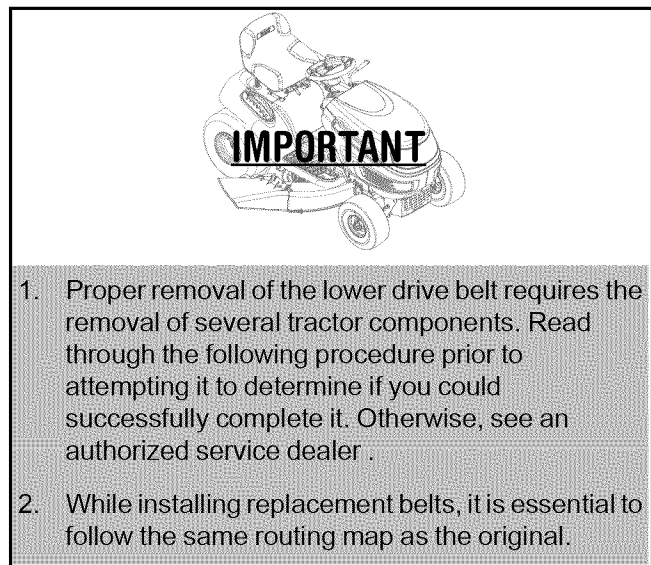

IMPORTANT: When remounting the engine pulley, torque the center hex bolt to between 38 and 50 foot-pounds.

6. Remove the drive belt by feeding it from both ends toward the front idler pulley on the double-idler bracket. See Figure 15.
 7. Reassemble by following the above steps in reverse order. Reroute the new belt around the pulleys, belt keepers and keeper pins **exactly** as the old one was routed. Refer to Figure 15.
- The drive pedal is properly adjusted when the hole in the double-idler bracket has approximately 1-3/8" of travel with ten pounds of pressure applied to the drive pedal. See Figure 16.

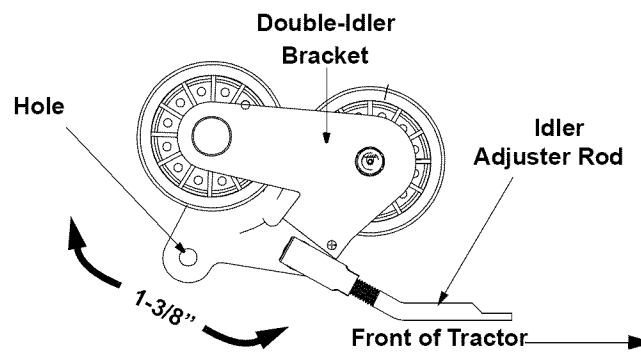

NOTE: View shown from above tractor.

Figure 16

After replacing the drive belts, adjust the drive pedal on your tractor as follows:

1. Locate the speed control assembly on the underside of the steering support bracket. See Figure 17.
2. Remove both hairpin clips from the pin which is fastened to the speed control assembly (be careful not to lose the small flat washers found on the pin). See Figure 17.
3. Remove the drive pedal return spring.
4. Using two 9/16" wrenches, remove the pin from the speed control assembly. See Figure 17.
5. Thread the idler adjustment rod inward or outward to lengthen or shorten the travel of the double-idler bracket until proper adjustment is achieved.
6. Reassemble by following the above steps in reverse order.

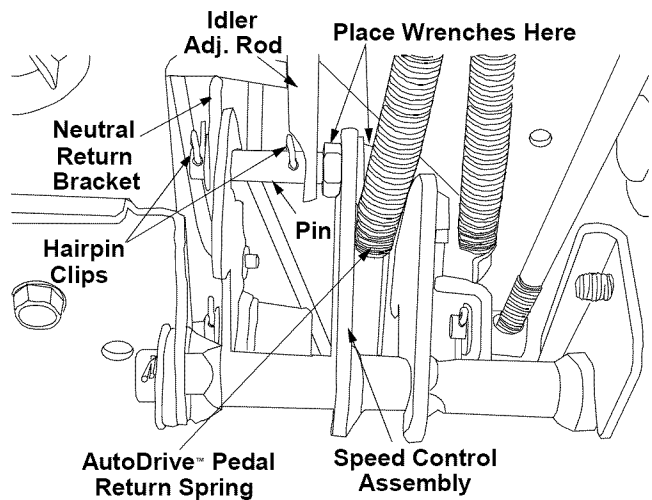

Figure 17

Changing the Deck Belt(s)

WARNING: Shut tractor engine off, remove ignition key, disconnect the spark plug wire(s) and ground against the engine before proceeding with job.

IMPORTANT: The V-belts on your tractor are specially designed to engage and disengage safely. A substitute (non-OEM) V-belt can be dangerous by not disengaging completely. For a proper working machine, use factory approved belts.

- All belts on the tractor are subject to wear and should be replaced if cracking, shredding or rotting occurs. To change or replace the deck belts on your tractor, proceed as follows:
 1. Lower the deck by moving the deck lift lever to the lowest position.
 2. Take the belt guards off by removing the self-tapping screws that fasten them to the deck surface. See Figure 18 & Figure 19 (as the case may be) for location of the screws.
 3. Grasp the PTO idler bracket and pivot it toward the discharge chute to relieve tension on the PTO belt.

Model 604G

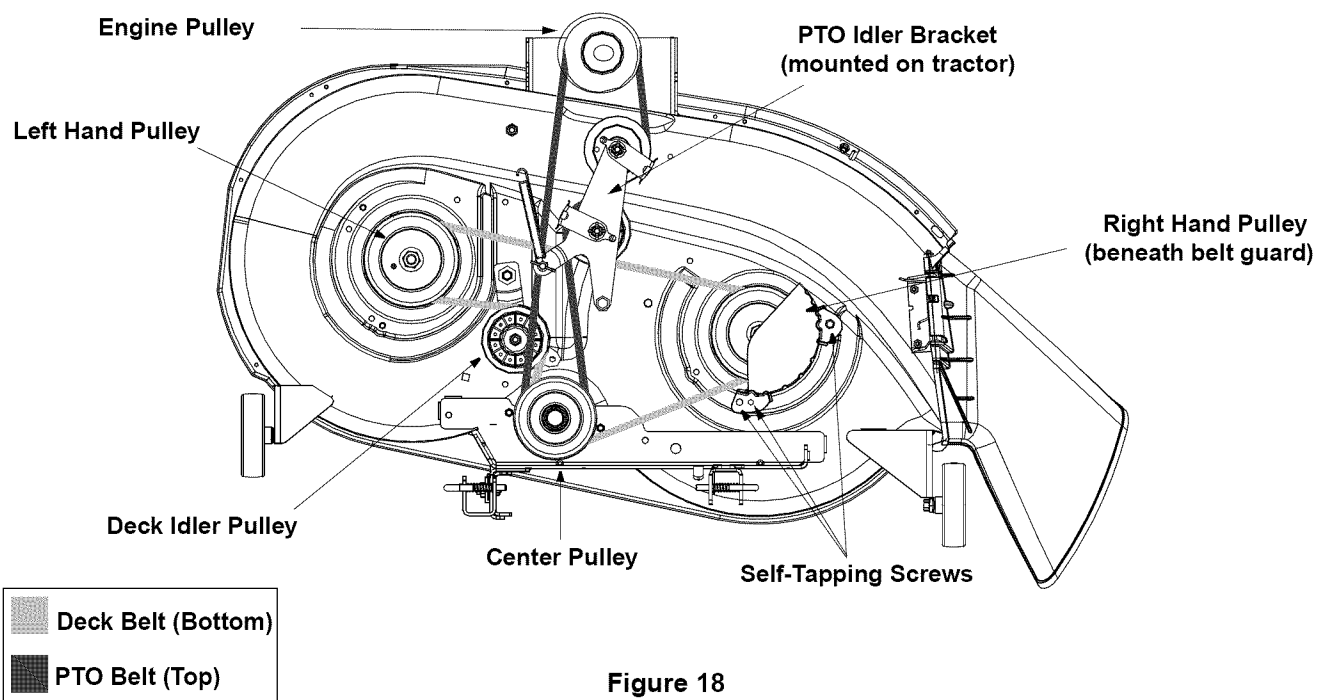

Figure 18

4. Remove the PTO belt from around the engine pulley and the PTO idler pulley.
5. Grasp the deck idler pulley and pivot it toward the left side of the deck to relieve tension on the deck belt.
6. Remove the belt from around all pulleys, including the deck idler pulley.
7. Route the new belts as in Figure 18 & Figure 19. Remount belt guards removed earlier.

Model 604H

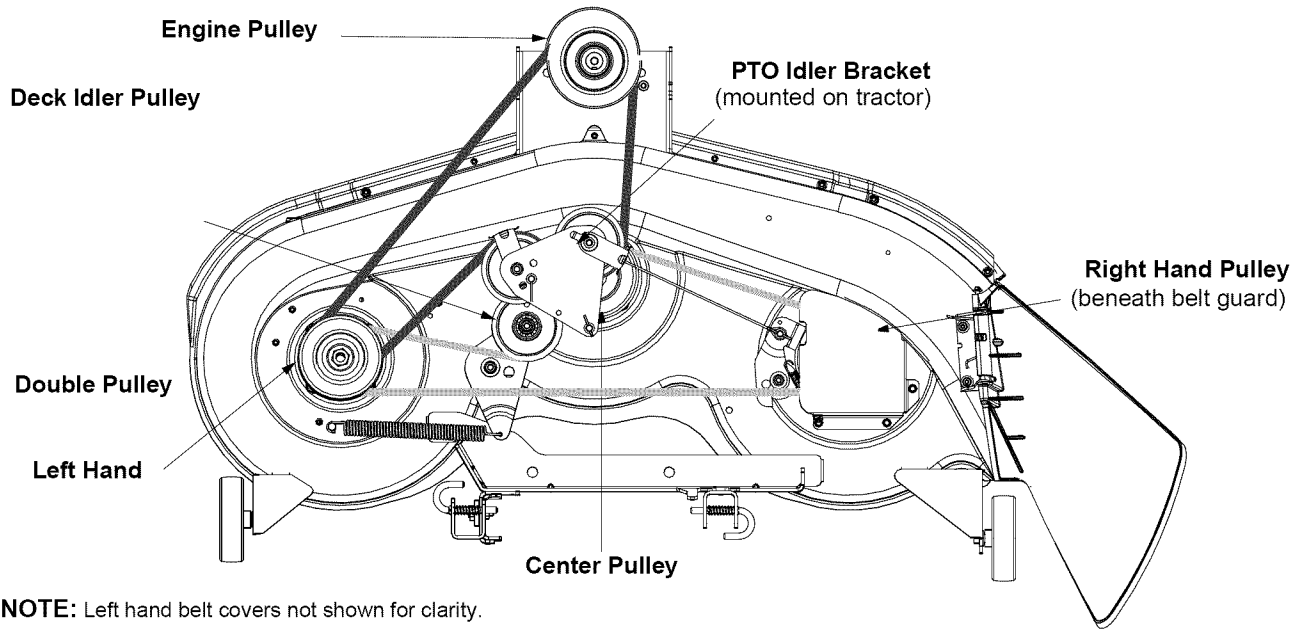

Figure 19

SECTION 7: OFF-SEASON STORAGE



WARNING: Never store the machine or fuel container indoors where there is an open flame, spark or pilot light such as on water heater, furnace, clothes dryer or other gas appliance.

- Clean and lubricate the tractor as instructed on page 17 before storing for an extended period.



WARNING: Drain fuel only into an approved container outdoors, away from an open flame. Allow engine to cool. Extinguish cigarettes, cigars, pipes, and other sources of ignition prior to draining fuel.

- Follow instructions in the **Seasonal Storage** section of the *engine manual* for proper engine care prior to storing your tractor.
- It is not necessary to remove the battery from the tractor for storage. However, clean the top of the battery and make sure it has full charge. Disconnect the negative terminal of the battery before storing the tractor.

NOTE: *Recharge the battery before returning it to service after storage. Even if the tractor starts, the engine charging system may not bring the battery upto a full charge, unless it is recharged.*

Attachments & Accessories

The following attachments and accessories are available for your lawn tractor. See your local retail store or dealer for price and availability.

MODEL	DESCRIPTION
OEM-190-116	42-inch Deck Mulch Kit
OEM-190-118	46-inch Deck Mulch Kit
OEM-190-601	FastAttach™ Twin Bagger Grass Collector (for 42-inch Decks)
OEM-190-602	FastAttach™ Twin Bagger Grass Collector (for 46-inch Decks)
OEM-190-603	FastAttach™ Grille Guard (mounts on front of tractor)
OEM-190-604	FastAttach™ Yard-Mate™ Storage Container/Toolbox (mounts on rear of tractor)
OEM-190-607	FastAttach™ Deluxe Tractor Sunshade
OEM-190-822	FastAttach™ 46-inch Front Dozer Blade
OEM-190-823	FastAttach™ 42-inch Two-stage Snow Thrower

SECTION 8: TROUBLESHOOTING

Trouble	Possible Cause(s)	Corrective Action
Engine fails to start	<ol style="list-style-type: none"> 1. PTO lever/knob engaged. 2. Parking brake not engaged. 3. Spark plug wire(s) disconnected. 4. Throttle control lever not in correct starting position. 5. Fuel tank empty, or stale fuel. 6. Blocked fuel line. 7. Faulty spark plug. 8. Engine flooded. 	<ol style="list-style-type: none"> 1. Place PTO lever/knob in OFF position. 2. Engage parking brake. 3. Connect wire(s) to spark plug. 4. Place throttle lever to CHOKE position. 5. Fill tank with clean, fresh gas. 6. Clean fuel line or replace fuel filter, if so equipped. 7. Clean, adjust gap or replace plug. 8. Crank engine with throttle in FAST position.
Engine runs erratic	<ol style="list-style-type: none"> 1. Unit running with CHOKE applied. 2. Spark plug wire loose. 3. Blocked fuel line or stale fuel. 4. Vent in gas cap plugged. 5. Water or dirt in fuel system. 6. Dirty air cleaner. 	<ol style="list-style-type: none"> 1. Place throttle lever in FAST position. 2. Connect and tighten spark plug wire. 3. Clean fuel line; fill tank with clean, fresh gas. Replace fuel filter, if so equipped. 4. Clear vent or replace cap if damaged. 5. Drain fuel tank. Refill with clean, fresh gas. 6. Replace air cleaner cartridge or clean pre-cleaner, if so equipped.
Engine overheats	<ol style="list-style-type: none"> 1. Engine oil level low. 2. Air flow restricted. 	<ol style="list-style-type: none"> 1. Fill crankcase with proper capacity and weight of oil. 2. Clean grass clippings and debris from around the engine's cooling fins and blower housing.
Engine hesitates at high RPM	<ol style="list-style-type: none"> 1. Spark plug gap too close. 	<ol style="list-style-type: none"> 1. Remove spark plug(s) and reset the gap at .030".
Idles poorly	<ol style="list-style-type: none"> 1. Spark plug fouled, faulty or gap too wide. 2. Dirty air cleaner. 	<ol style="list-style-type: none"> 1. Replace spark plug(s). Set plug gap at .030". 2. Replace air cleaner cartridge or clean pre-cleaner, if so equipped.
Excessive vibration	<ol style="list-style-type: none"> 1. Cutting blade loose, unbalanced or damaged. 	<ol style="list-style-type: none"> 1. Tighten blade and spindle, balance blade and/or replace blade.
Mower will not mulch grass	<ol style="list-style-type: none"> 1. Engine speed too low. 2. Wet grass. 3. Excessively high grass. 4. Dull blade. 	<ol style="list-style-type: none"> 1. Place throttle in FAST (rabbit) position. 2. Do not mow when grass is wet; wait until later to cut. 3. Mow once at a high cutting height, then mow again at desired height or make a narrower cutting swath. 4. Sharpen or replace blade.
Uneven cut	<ol style="list-style-type: none"> 1. Deck not balanced properly. 2. Dull blade. 3. Uneven tire pressure. 	<ol style="list-style-type: none"> 1. Perform side-to-side deck adjustment. 2. Sharpen or replace blade. 3. Check tire pressure in all four tires.

NOTE: For unsolved problems and/or further details, visit www.mtdproducts.com or call the Customer Support Line at 1-800-800-7310.

SECTION 9: PARTS LIST FOR MODELS 604G & 604H

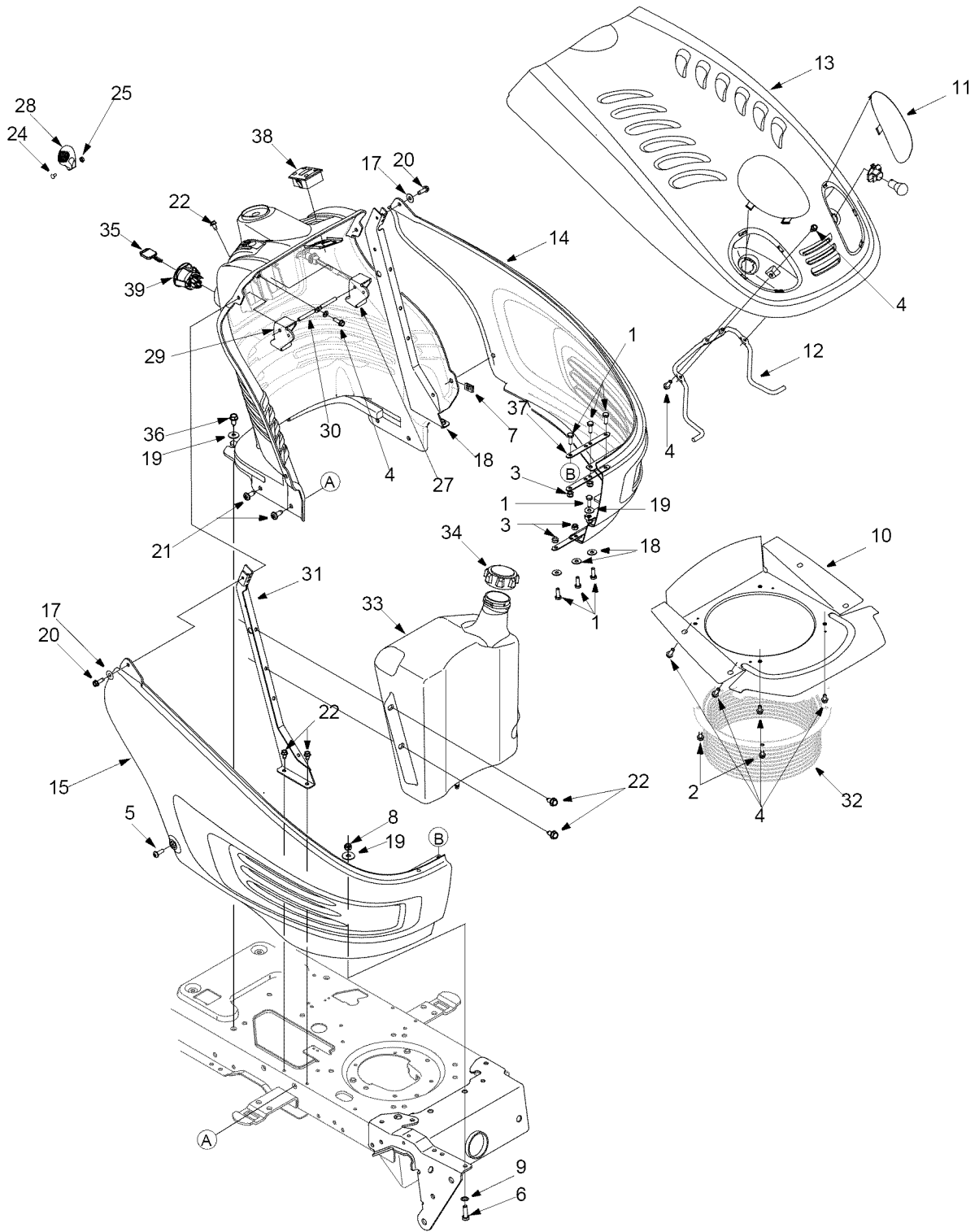

Models 604G & 604H

REF. NO.	PART NO.	DESCRIPTION	REF. NO.	PART NO.	DESCRIPTION
1	710-3015	Hex Cap Screw, 1/4-20 x .75	22	710-0599	Self-tapping Screw, 1/4-20 x .50
2	710-0599	Self-tapping Screw, 1/4-20 x .5	23	710-1017	Torx Self-tapping Screw, 1/4-14 x .625
3	712-0324	Hex Lock Nut, 1/4-20	24	710-3217	Torx Screw, #8-32 x .375
4	710-0895	Self-tapping Screw, 1/4-15 x .75	25	712-0142	Hex Nut, 8-32
5	710-0924	Pan Phillips Screw, 1/4-20 x .75	26	731-0069D	Dash Panel
6	710-0376	Hex Cap Screw, 5/16-18 x 1.0	27	731-0072	Parking Brake Button
7	712-0292	U-type Speed Nut, 1/4-20	28	731-1857	Throttle Control Lever
8	712-0429	Lock Nut, 5/16-18	29	731-2106	Cruise Control Button
9	726-0201	Speed Nut	30	747-1155	Brake/Cruise Pivot Rod
10	783-0808A	Hood Heat Shield	31	783-04285	Dash Support Plate RH
11	731-1978	RH Headlight Lens	32	731-2234	Intake Bellow
	731-1979	LH Headlight Lens	33	751-0658E	Fuel Tank, 3-gallon
12	747-1132A	Hood Support Rod	34	751-0603	Fuel Cap
13	731-1980A	Hood	35	725-1745	Ignition Key w/ plastic cover
14	731-1981C	LH Side Panel		725-1744	Ignition Key w/o plastic cover
15	731-1982C	RH Side Panel	36	710-0726	Self-tapping Screw, 5/16-18 x .75
16	736-0329	Lock Washer, 1/4	37	783-1000A	Grille Support Bracket
17	736-0342	Flat Washer, .283 x .75 x .030	38	725-1758	Systems Indicator Monitor, Ammeter
18	783-04323	Dash Support Plate LH	39	725-1741	Ignition Switch
19	736-3078	Flat Washer, .349 x 1.0 x .063	40	625-0051	Headlight Assembly
20	710-0809	Self-tapping Screw, 1/4-20 x 1.25	—	629-0469B	Headlight Wire Harness
21	710-1611B	Self-tapping Screw, 5/16-18 x .75	—	629-1072	Tractor Wire Harness

Models 604G & 604H

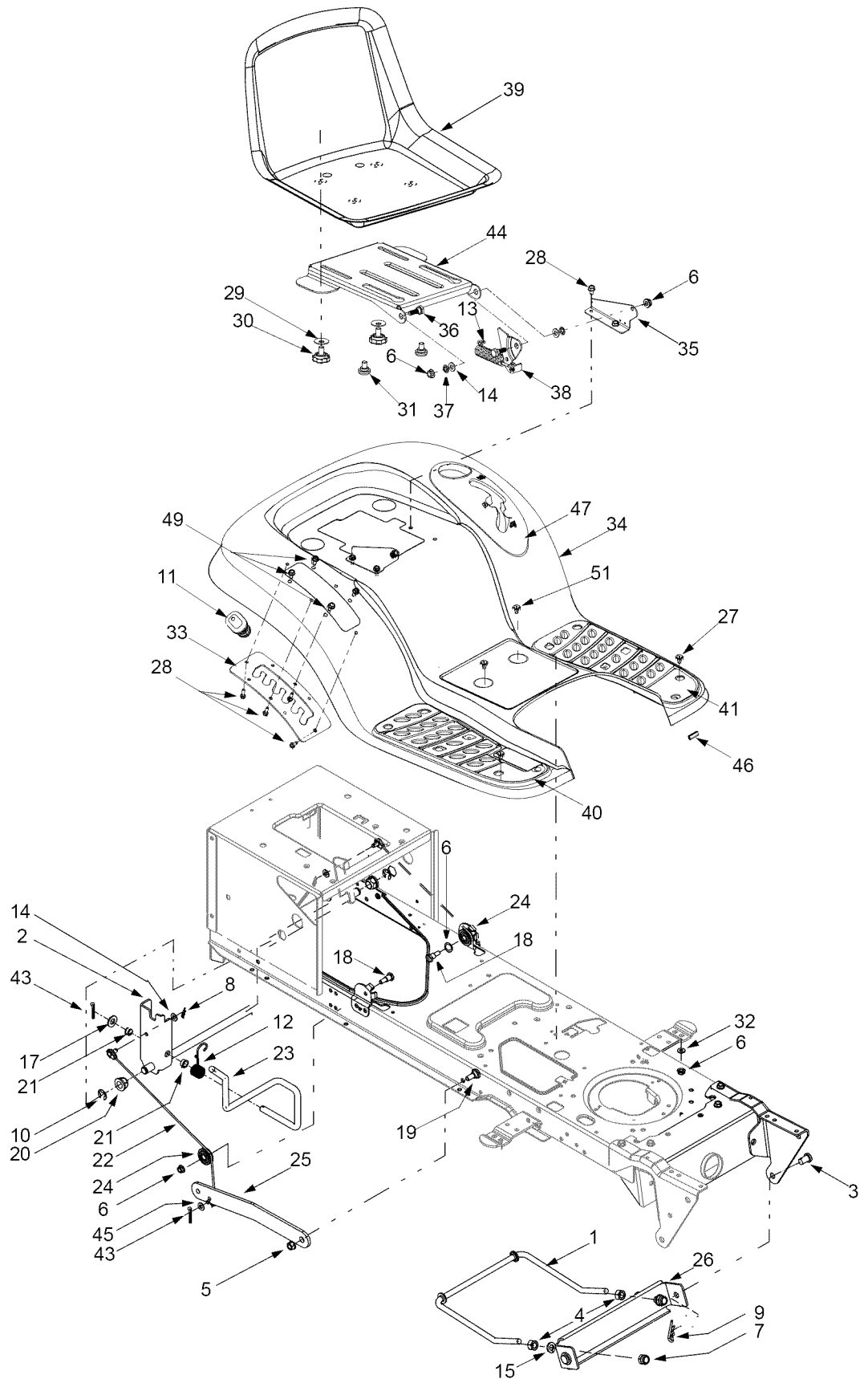

Models 604G & 604H

Ref. No.	Part No.	Description
1	747-1130B	Deck Stabilizer Rod
2	683-0197B	Lift Shaft Assembly
3	711-0332	Clevis Pin, .5 x .78
4	712-0206	Hex Nut, 1/2-13
5	712-0431	Flange Lock Nut, 3/8-16
6	712-0429	Lock Nut, 5/16-18
7	712-3083	Hex Nut, 1/2-13
8	714-0104	Internal Cotter Pin
9	714-0145	Internal Cotter Pin
10	716-0106	E-Ring
11	720-0311	Handle Grip
12	732-0874	Torsion Spring
13	732-1184	Extension Spring, .84 x 4.6
14	736-0275	Flat Washer, 5/16
15	736-0921	Lock Washer, 1/2
16	736-3019	Flat Washer, .531 x 1.062 x .134
17	736-3084	Flat Washer, .51 x 1.12 x .06
18	738-0138A	Hex Cap Screw, 5/16-18 x .62
19	738-0143	Shoulder Screw, 3/8-16
20	741-0225	Hex Flange Bearing
21	741-0715	Snap Flange Bearing
22	746-0968	Lift Cable, 16.16 (Model 604G)
	746-1144	Lift Cable, 15.62 (Model 604H)
23	747-1111A	Lift Handle
24	756-1154	Roller Pulley
25	783-0678A	Lift Arm
26	783-0720A	Deck Stabilizer Bracket
27	710-0260A	Carriage Bolt, 5/16 x .62
28	710-0604A	Self-tapping Screw, 5/16-18 x .625
29	736-0331	Bell Washer, .390 x 1.13 x .062
30	720-04009	Knob, 3/8-16
31	738-04012	Shoulder Screw
32	736-3078	Flat Washer, .349 x 1.0 x .063
33	783-1010A	Lift Adjustment Bracket
34	783-04314	Fender (Models w/Cup Holder)
35	783-1489	Seat Mounting Bracket
36	738-0296	Shoulder Screw
37	726-0201	Speed Clip
38	783-0209C	Seat Lift Bracket
39	757-04011B	Seat: Medium Back Yellow
40	735-0672	Foot Pad RH, Rubber
41	735-0673	Foot Pad LH, Rubber
42	726-3046	Foot Pad Clips
43	714-0111	Cotter Pin
44	783-04081A	Seat Pivot Bracket
45	736-0204	Flat Washer, .344 x .62
46	731-0511	Trim Strip
47	731-1990	Lift Lever Cover
48	731-2104B	Shift Lever Cover w/ Cup Holder
49	710-0895	Self-Tapping Screw, 1/4-15 x .75
50	731-04591	Cup Holder
51	710-0599	TT Screw, 1/4-20 x 0.5

Models 604G & 604H

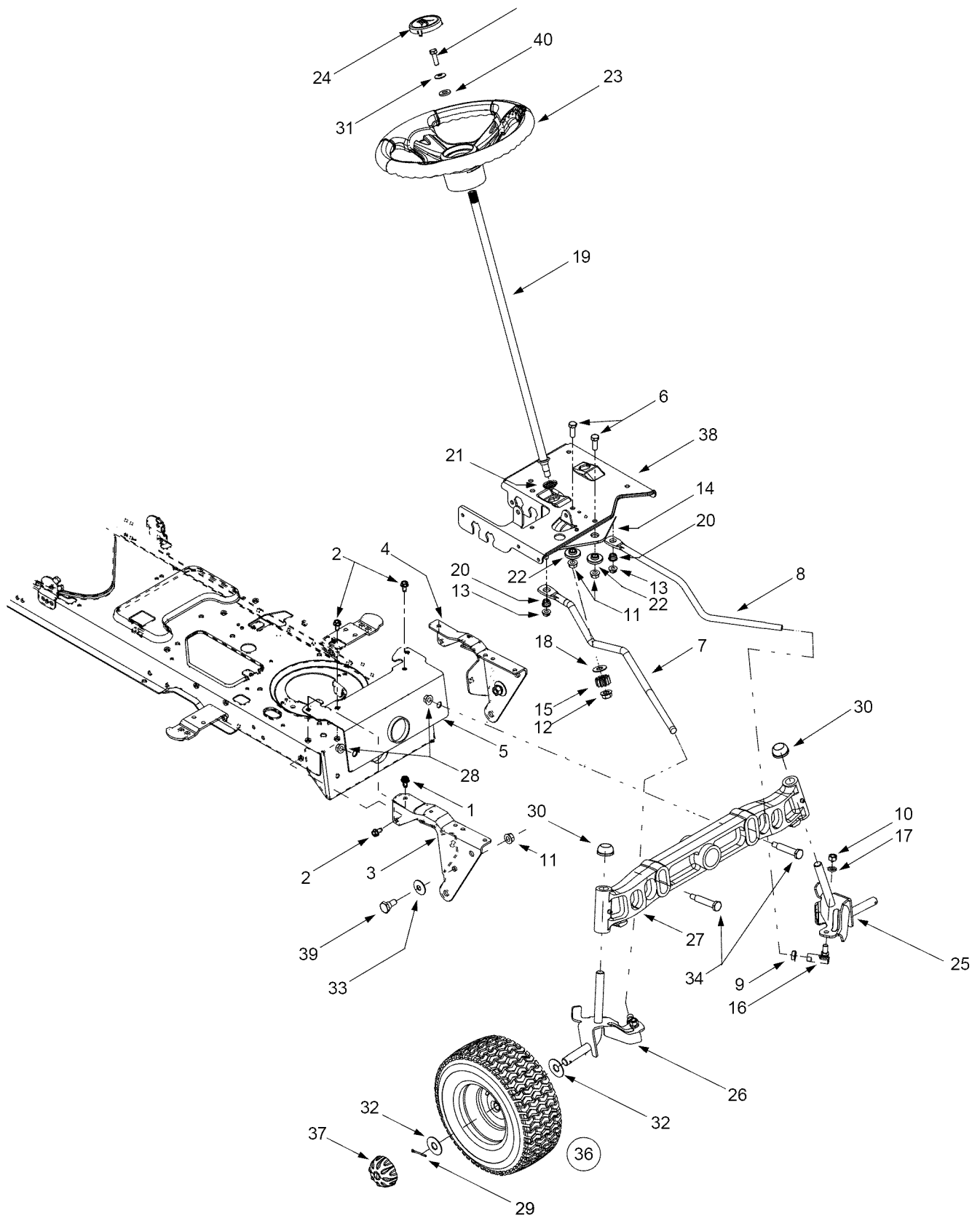

Models 604G & 604H

Ref. No.	Part No.	Description
1	710-1260A	Self-tapping Screw, 5/16-18 x .75
2	710-0604A	Self-tapping Screw, 16-18 x .625
3	783-0726B	RH Pivot Support Bracket
4	783-0727A	LH Pivot Support Bracket
5	783-0728	Pivot Bar Bracket
6	710-0514	Hex Cap Screw, 3/8-16 x 1 (Grade 5)
7	711-1408	RH Drag Link
8	711-1409A	LH Drag Link
9	712-0240	Jam Nut, 7/16-20 (Grade 2)
10	712-0241	Hex Nut, 3/8-24 (Grade 2)
11	712-0431	Flange Lock Nut, 3/8-16
12	712-0459	Flange Lock Nut, 7/16-20
13	712-3004A	Flange Lock Nut, 5/16-18
14	717-1550D	Steering Gear, 11/90 Ratio
15	717-1554	Steering Pinion Gear
16	723-0448A	Ball Joint, 7/16-20
17	736-0169	Lock Washer, 3/8
18	736-3084	Flat Washer, .51 x 1.12 x .06
19	738-1001A	Steering Shaft, .625 OD x 24.4
20	741-0475	Plastic Bushing, .38 ID
21	741-0656	Hex Flange Bearing, 5/8
22	738-0372B	Shoulder Spacer, .38 ID
23	631-04008	Steering Wheel, Soft Grip, Three Spoke
24	731-04040	Steering Wheel Cover
25	638-0019A	LH Axle Assembly (Model 604G)
	638-0021	LH Axle Assembly (Model 604H)
26	638-0020A	RH Axle Assembly (Model 604G)
	638-0022	RH Axle Assembly (Model 604H)
27	719-0399B	Pivot Bar w/ Fittings (Model 604G)
	719-0525B	Pivot Bar w/ Fittings (Model 604H)
28	712-0431	Flange Lock Nut, 3/8-16
29	714-0162	Cotter Pin
30	726-0214	Push Cap, .625 (Model 604G)
	726-0341	Push Cap, .750 (Model 604H)
31	736-0242	Bell Washer, .34 x .872
32	736-0285	Flat Washer, .635 x 1.589 x .06
33	736-0331	Bell Washer, .39 x 1.13 x .062
34	738-1011	Shoulder Screw, .5 x 2.2, 3/8-16
35	710-0643	Hex Bolt, 5/16-18 X 1
36	634-04086	Wheel Assembly Complete
—	634-04081	Rim Only
—	734-0255	Air Valve (Not Shown)
—	734-1731	Tire Only, Square Shoulder
—	741-0516A	Flange Bearing (Not Shown)
—	741-0990A	Flange Bearing w/ Fitting (Not Shown)
37	734-2290A	Hub Cap
38	783-0653F	Steering Support Bracket
39	738-0143	Shoulder Screw, 3/8-16
40	736-3004	Flat Washer, .406 x .875 x .105

Models 604G & 604H

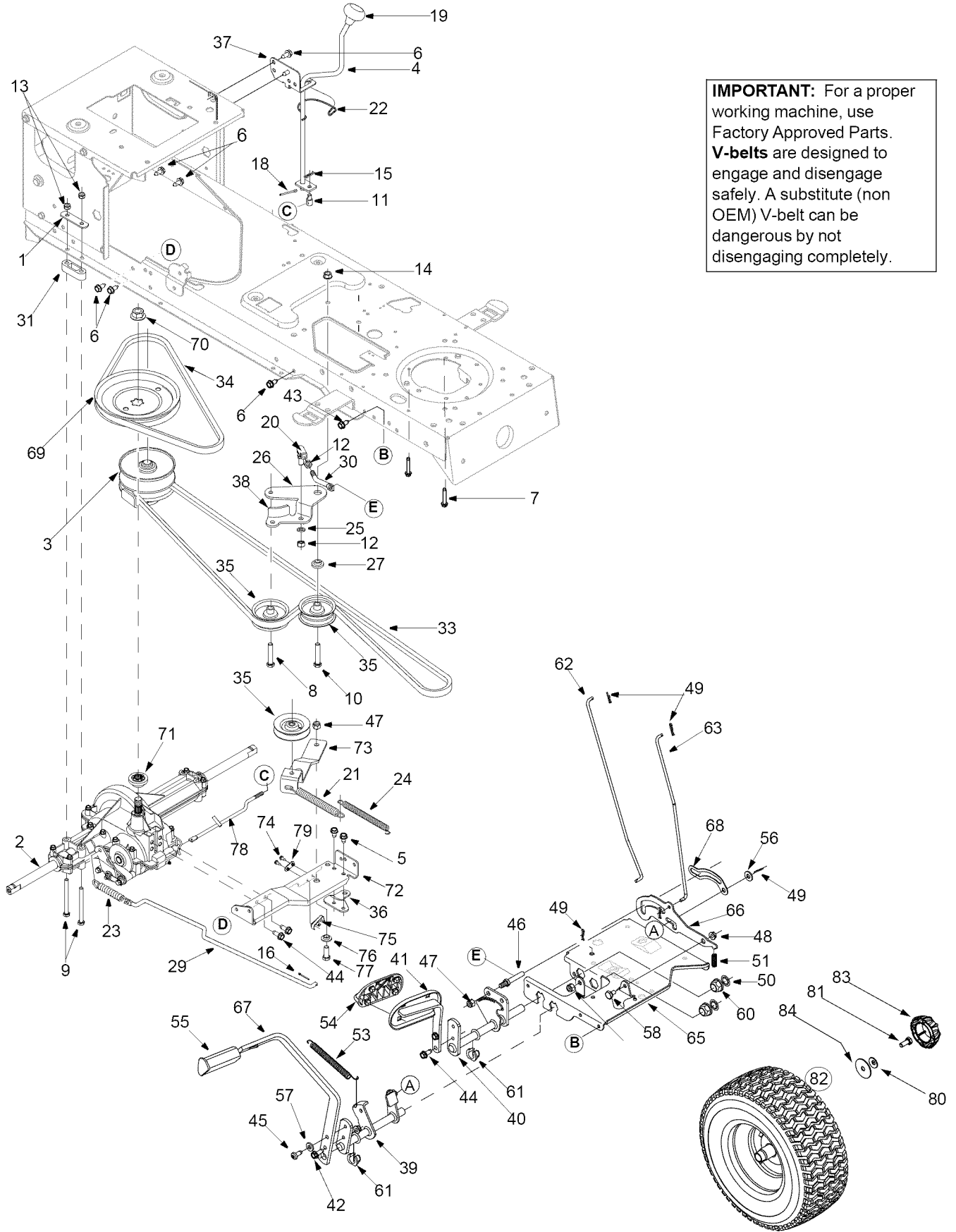

IMPORTANT: For a proper working machine, use Factory Approved Parts. **V-belts** are designed to engage and disengage safely. A substitute (non OEM) V-belt can be dangerous by not disengaging completely.

Models 604G & 604H

Ref. No.	Part No.	Description	Ref. No.	Part No.	Description
1	17840	Mounting Bracket	43	710-0726	AB Screw 5/16-12 x 0.75
2	618-04133	Drive Assembly	44	710-1260A	LD Screw 5/16-18 x 0.75
3	618-04147	Variable Spd. Pulley Assembly	45	710-1611B	TT Screw 5/16-18 x 0.75
4	647-04020	Shift Lever Assembly	46	711-04159	Pin
5	710-0607	TT Screw 5/16-18 x 0.5	47	712-0130	Hex Lock Nut 3/8-16
6	710-0726	AB Screw 5/16-12 x 0.75	48	712-3004A	Flange Lock Nut
7	710-0809	TT Screw 1/4-20 x 1.25	49	714-0104	Cotter Pin
8	710-1007	TT Sems Screw 3/8-16 x 1.5	50	726-04028	Push Nut
9	710-1266	Hex Bolt 5/16-18 x 3.5	51	732-0335	Compression Spring
10	710-3144	Hex Bolt 3/8-16 x 2.0	53	732-0963	Extension Spring
11	711-0736	Ferrule	54	735-0662	Control Pad
12	712-0241	Hex Nut 3/8-24	55	735-3049	Brake Pad
13	712-0429	Hex Lock Nut 5/16-18	56	736-0262	Flat Washer
14	712-0431	Flange Lock Nut 3/8-16	57	736-3008	Flat Washer
15	714-0104	Hairpin Clip	58	738-0155	Shoulder Screw
16	714-0111	Cotter Pin	60	741-0225	Hex Flange Bearing
17	714-0209	Hairpin Clip	61	741-3065B	Hex Flange Bearing: Split
18	714-0470	Cotter Pin	62	747-04093	Brake Lock Rod
19	720-04028	Shift Knob	65	783-0653F	Steering Support Bracket
20	723-3018	Ball Joint	66	783-0732	Lock-Out Bracket
21	732-0384	Extension Spring	67	783-0773A	Brake Pedal
22	732-0525	Spring Clip	68	783-0780B	Neutral Return Bracket
23	732-0716	Extension Spring	69	756-04002	Transmission Pulley
24	732-0963	Extension Spring	70	712-0700	Flange Nut 9/16-18
25	736-0169	Lock Washer 3/8	71	718-0758A	Pulley Hub
26	737-3007	Grease	72	683-04055	Transmission Torque Bracket
27	738-0372B	Shoulder Spacer	73	683-04130	Idler Bracket
28	747-04146	Shift Rod	74	710-0227	AB Screw #8-18 x 0.5
29	747-04164	Brake Rod	75	725-1644	Spring Switch
30	747-1127	Idler Adj. Rod	76	750-0736	Shoulder Spacer
31	748-0334	Spacer: Transaxle	77	710-0514	Hex Bolt 3/8-16 x 1.0
32	750-0566A	Spacer	78	747-04146	Shift Rod
33	754-0467	V Belt	79	726-0320	Insulator Nut Plate
34	754-0468	V Belt	80	736-0242	Bell Washer
35	756-0981A	Flat Idler Pulley	81	710-0627	Hex Cap Screw
36	783-04283	Shift Bracket	82	634-0104	Wheel Assembly
37	783-04360	Shift Bracket		634-0070	Rim Assembly
38	783-04442	Double Idler Bracket: Center		734-0255	Air Valve
39	647-0031C	Brake Control Assembly		734-1730	Tire
40	647-0032A	Speed Control Assembly	83	734-2290A	Hub Cap
41	683-0266	Drive Pedal Assembly	84	736-0430	Flat Washer
42	710-0650	TT Screw 5/16-18 x 0.875			

Models 604G & 604H

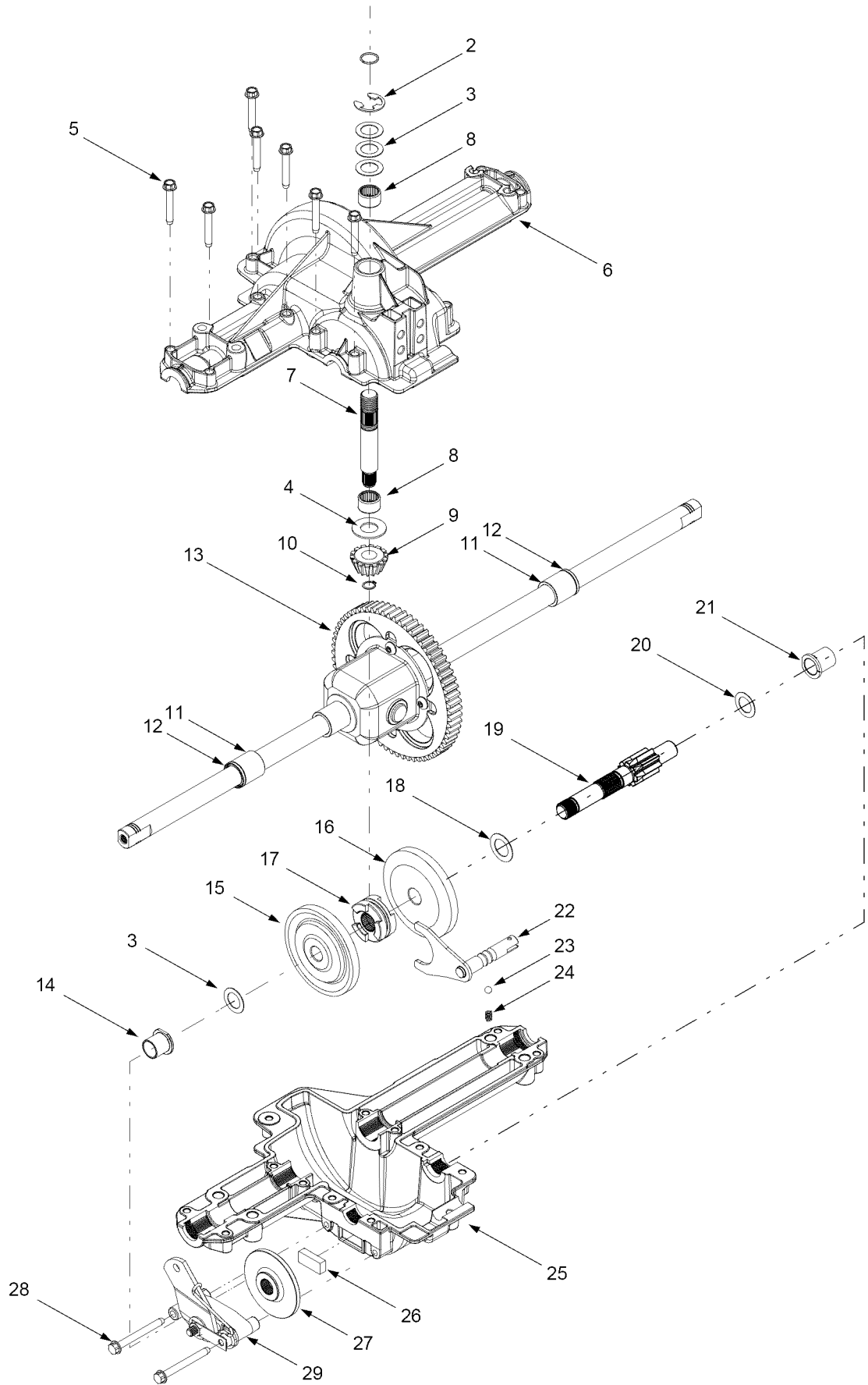

Models 604G & 604H

Ref. No.	Part No.	Description
1	732-0614	Ring, Wire
2	716-0231	Ring, E Type, .750
3	736-0336	Flat Washer, 5/8 x 1.0 x .030*
	736-0337	Flat Washer, 5/8 x 1.0 x .040*
	736-0349	Flat Washer, 5/8 x 1.0 x .020*
4	736-0335	Washer, Thrust .635 x 1.26 x .06
5	710-1325	Self-tapping Screw, 1/4-20 x 1.625
6	719-04017	Upper Housing
7	711-1109	Input Shaft
8	741-0335	Needle Bearing, .625 x .813 x .495
9	717-1464	14-tooth Bevel Pinion
10	716-0108	Retaining Ring, .437
11	741-0340	Sleeve Bearing, .75 x .1.0 x 1.0
12	721-0338	Seal, .75 x 1.0 x .125
13	618-04041	Differential Assembly
14	741-0336	Flange Bearing, 5/8 x 3/4 x 3/4
15	717-1362	42-tooth Bevel Gear
16	717-1363	42-tooth Bevel Gear
17	718-0228	Clutch Collar
18	736-0519	Flat Washer, .70 x 1.125 x .031
19	711-04053	Drive Shaft
20	736-0495	Thrust Washer, 1.0 x .632 x .0
21	741-0337	Flange Bearing, 5/8 x 3/4 x 15/16
22	611-0011	Detent Shaft Assembly
23	741-0862	Detent Ball
24	732-0863	Compression Spring
25	719-04018	Lower Housing
26	717-0678	Brake Puck
27	761-0202	Brake Disc
28	710-1206	Self-tapping Screw, 1/4-20 x 2.375
29	661-0001	Brake Assembly
—	737-0148	Grease (19 oz.)

*Use applicable flat washer (12a, 12b or 12c) in this application allowing .0150/.0020 in end-play

NOTE: *If rebuilding the upper housing of the transmission, add two ounces of Unirex[®] N3 grease (Part No. 737-0289) in the input shaft cavity.*

Models 604G & 604H

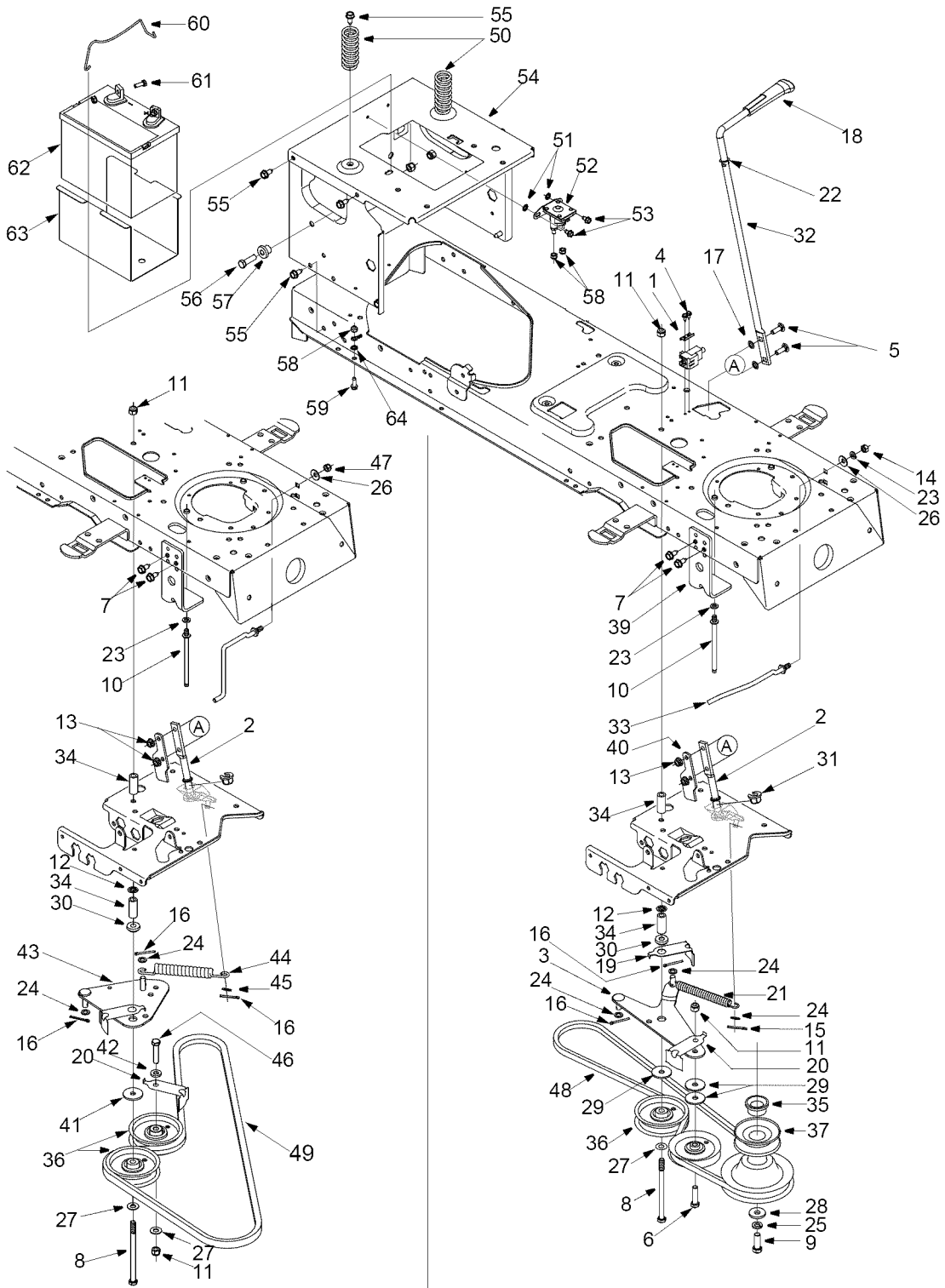

Model 604H

Model 604G

Models 604G & 604H

Ref. No.	Part No.	Description	Ref. No.	Part No.	Description
1	17962	Switch Plate	33	747-1286A	Rod: Belt Keeper
2	647-0064	Lever Assembly: PTO Engage	34	748-0415B	Spacer
3	683-0450	Plate Assembly: PTO Engage	35	750-0956	Spacer
4	710-0224	AB Screw #10-16 x 0.5	36	756-0627B	Idler Pulley
5	710-0276	Carriage Screw: Special	37	756-0982B	Engine Pulley
6	710-0520	Hex Bolt 3/8-16 x 1.5	38	756-1208	Idler Pulley
7	710-0726	AB Screw 5/16-12 0.75	39	783-04467	Bracket: Deck Stop
8	710-0831	Hex Bolt 3/8-16 x 5.5	40	783-0744A	Bracket: Stop
9	710-3029	Hex Bolt 7/16-20 x 1.25	41	738-0227	Flat Washer
10	711-1044	Belt Guard Pin	42	736-3010	Flat Washer
11	712-0130	Lock Nut	43	683-0302	Engagement Plate Assembly
12	712-0229	Push Nut	44	732-0944	Extension Spring
13	712-3004A	Flange Lock Nut	45	736-0275	Flat Washer
14	712-3010	Hex Nut 5/16-18	46	710-0347	Hex Bolt 3/8-16 x 1.75
15	714-0104	Cotter Pin	47	712-0429	Hex Lock Nut 5/16-18
16	714-0470	Cotter Pin	48	754-0497	V Belt
17	726-0201	Speed Nut	49	754-0349	V Belt
18	731-2111A	PTO Knob	50	732-04035	Compression Spring
19	732-0991A	Belt Guard	51	736-0222	Lock Washer
20	732-1013	Belt Guard	52	725-1426	Solenoid
21	732-1170	Extension Spring	53	710-0599	TT Screw 1/4-20 x 0.5
22	736-0108	Flat Washer	54	783-04329	Seat Bracket
23	736-0119	Lock Washer	55	710-0726	AB Screw 5/16-12
24	736-0140	Flat Washer	56	710-3005	Hex Bolt 3/8-16 x 1.25
25	736-0171	Lock Washer	57	738-04058	Shoulder Spacer
26	736-0242	Bell Washer	58	712-0324	Lock Nut 1/4-20
27	736-0300	Flat Washer	59	710-0642	TT Screw 1/4-20 x 0.75
28	736-0322	Flat Washer	60	747-04121A	Battery Hold-Down Rod
29	736-3039	Flat Washer	61	710-0703	Carriage Screw
30	736-0372B	Spacer	62	725-1706A	Battery
31	741-0708	Hex Split Flange Bearing	63	783-0349	Battery Tray
32	747-1112D	Handle: Deck Engage	64	738-0143	Shoulder Screw 3/8-16

Models 604G & 604H

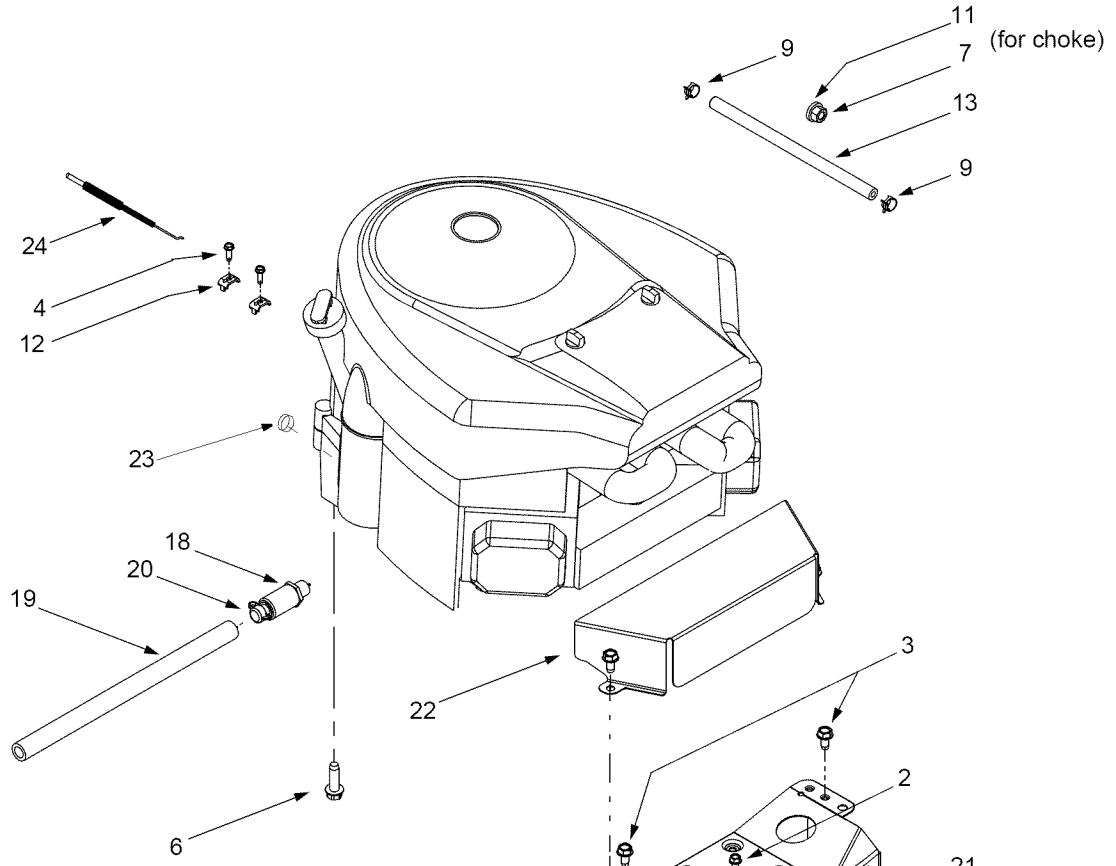

REF. NO.	PART NO.	DESCRIPTION
1	710-0227	Self-tapping Screw, #8-18 x .5
2	710-0599	Self-tapping Screw, 1/4-20 x .5
3	710-0604A	Self-tapping Screw, 5/16-18 x .625
4	710-1237	Screw, #10-32 x .625
5	710-1314A	Socket Cap Screw, 5/16-18 x .625
6	710-1315	Self-tapping Screw, 3/8-16 x 1.25
7	712-3017	Hex Nut, 3/8-16
8	721-0460	Exhaust Gasket
9	726-0205	Hose Clamp
10	725-0157	Cable Tie (not shown)
11	736-0300	Flat Washer
12	751B221535	Casing Clamp
13	751-0535	Fuel Line Hose
14	751-0564	Muffler Deflector
15	751-0616	Muffler, Twin Inlet
16	751-0650	RH Exhaust Pipe
17	751-0651	LH Exhaust Pipe
18	751-3140	Oil Drain Valve
19	751-3141	Oil Drain Hose
20	751-3142	Oil Drain Cap
21	783-0615B	Muffler Heat Shield
22	783-0625C	Engine Heat Shield
23	712-0271	Sems Nut 1/4-20
24	746-1086	Throttle Cable

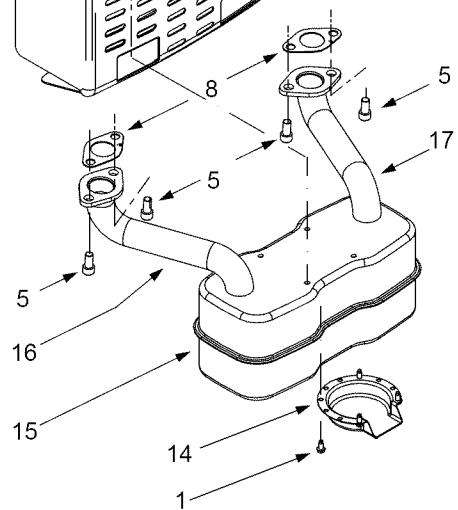

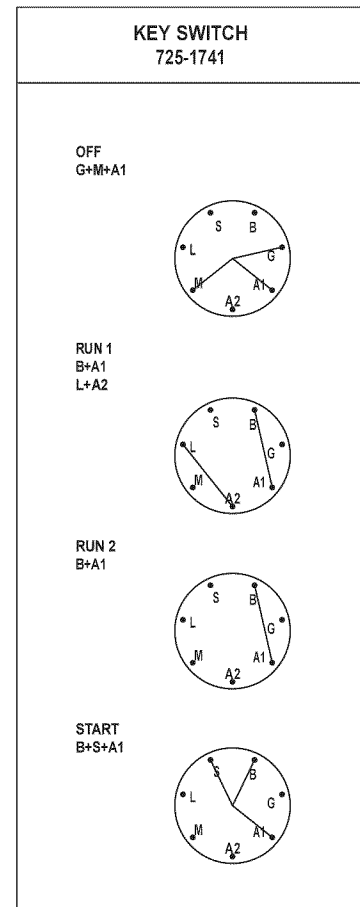
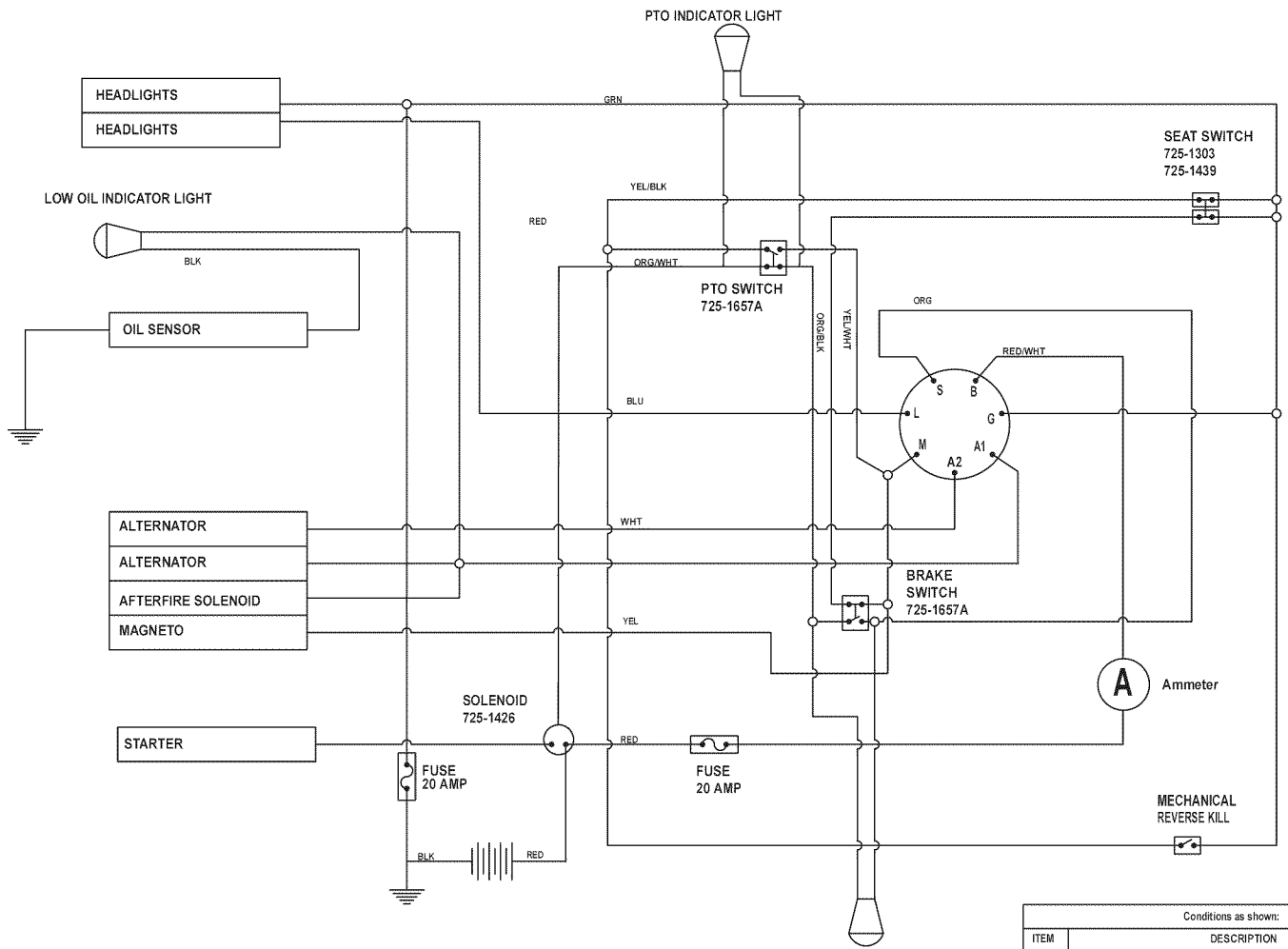

Conditions as shown:

ITEM	DESCRIPTION
1	KEY SWITCH OFF
2	PTO OFF
3	TRACTOR UNOCCUPIED
4	BRAKE SWITCH OFF

Model 604G

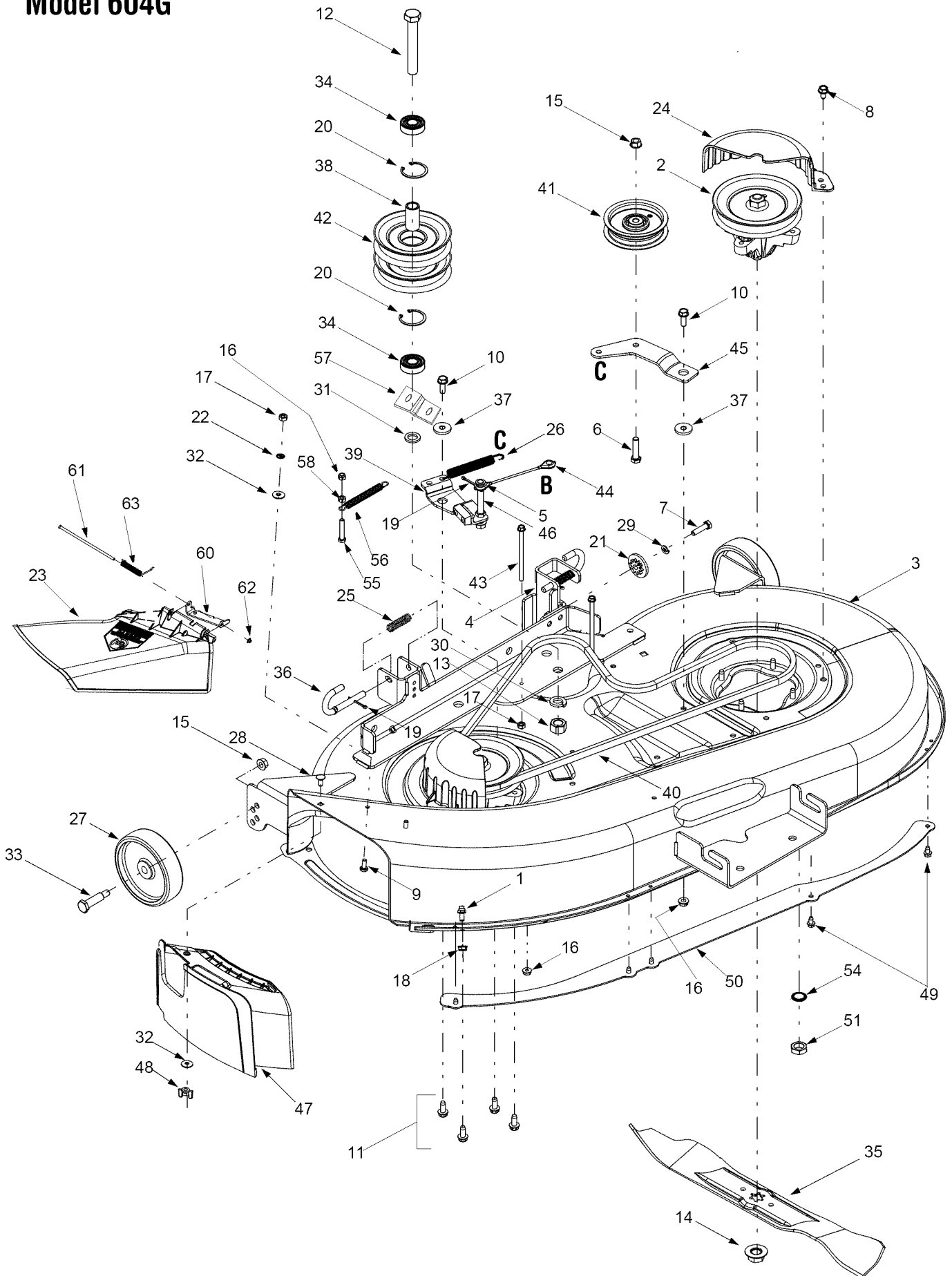

Model 604G

Ref. No.	Part No.	Description	Ref. No.	Part No.	Description
1	711-04069	Grass Catcher Pin, 1/4-20	32	736-0270	Bell Washer, .265 x .75 x .062
2	618-0565	Spindle Assy., 5.75 Dia. w/ Fitting	33	738-0373	Shoulder Screw, .498 x 1.53
3	683-0198G	42-inch Deck Shell	34	741-0524	Bearing, .625 x 1.574 x .470
4	683-0254	Deck Adj. Bracket w/ Weld Nut	35	742-0616A	Blade, Star Center, 21.23"
5	736-0140	Flat Washer, .385 x .62 x .063	36	747-1116	Deck Release Pin
6	710-0520	Hex Cap Screw, 1/4-20 x 1.5	37	748-0331	Shoulder Spacer, .625 x .324
7	710-0528	Hex Cap Screw, 5/16-18 x 1.25	38	750-0932A	Spacer, .635 x .88 x 1.72
8	710-0726	Self-tapping Screw, 5/16-12 x .75	39	683-0440	Deck Brake Assembly
9	710-0751	Hex Cap Screw, 1/4-20 x .62	40	754-0498	Deck Belt
10	710-1238	Hex Hd. Washer Scr., 5/16-18 x .875	41	756-0627B	Idler Pulley, 3.5
11	710-0650	Self-tapping Screw, 5/16-18 x .875	42	756-1202	Double Pulley, 5.0
12	710-3151	Hex Cap Screw, 5/8-18 x .875	43	710-1830	Self-tapping Screw, 1/4-20 x 4.0
13	712-0337	Hex Nut, 5/8-18	44	746-0970	Brake Cable, 5.05
14	712-0417A	Hex Flange Nut, 5/8-18	45	783-1291	Idler Bracket
15	712-0431	Flange Lock Nut, 3/8-16	46	711-1534	Pin, 3/8-16, 3/8 x 3.27
16	712-0429	Flange Lock Nut, 5/16-18	47	731-2363	Mulch Plug
17	712-3006	Hex Nut, 1/4-20	48	712-3087	Wing Nut
18	712-0324	Hex Lock Nut, 3/8-16	49	710-0599	Self-Tapping Screw, 1/4-20 x .5
19	714-0470	Cotter Pin, 1/8 x 1.25	50	783-1146A	Deck Skirt
20	716-3020	Internal Snap Ring	51	712-0641	Hex Nut, M-16 x 1.5
21	717-04074	Deck Adjustment Gear	54	736-0760	Lock Washer
22	726-0233	Push Nut, .25 x .5	55	710-3180	Hex Bolt, 5/16-18 x 1.75
23	731-1031C	Side Discharge Chute Assembly	56	732-1165	Extension Spring
24	731-2486A	Belt Cover	57	783-04013A	Stab. Bracket: Pulley
25	732-0306A	Comp. Spring, .406 x .531 x 1.75	58	712-3010	Hex Nut
26	732-0470A	Extension Spring, .50 x 4.74	59	783-1025	Chute Stop (not shown)
27	734-0973	Deck Wheel, 5 x 1.38	60	703-1693A	Mount. Bracket
28	710-0134	Carriage Screw, 1/4-20 x .5	61	711-0792	Hinge Pin
29	736-0119	Lock Washer, 5/16	62	726-0106	Speed Nut
30	736-0158	Lock Washer, 5/8	63	732-0602A	Torsion Spring
31	736-0162	Flat Washer, .64 x 1.0 x .12			

Model 604H

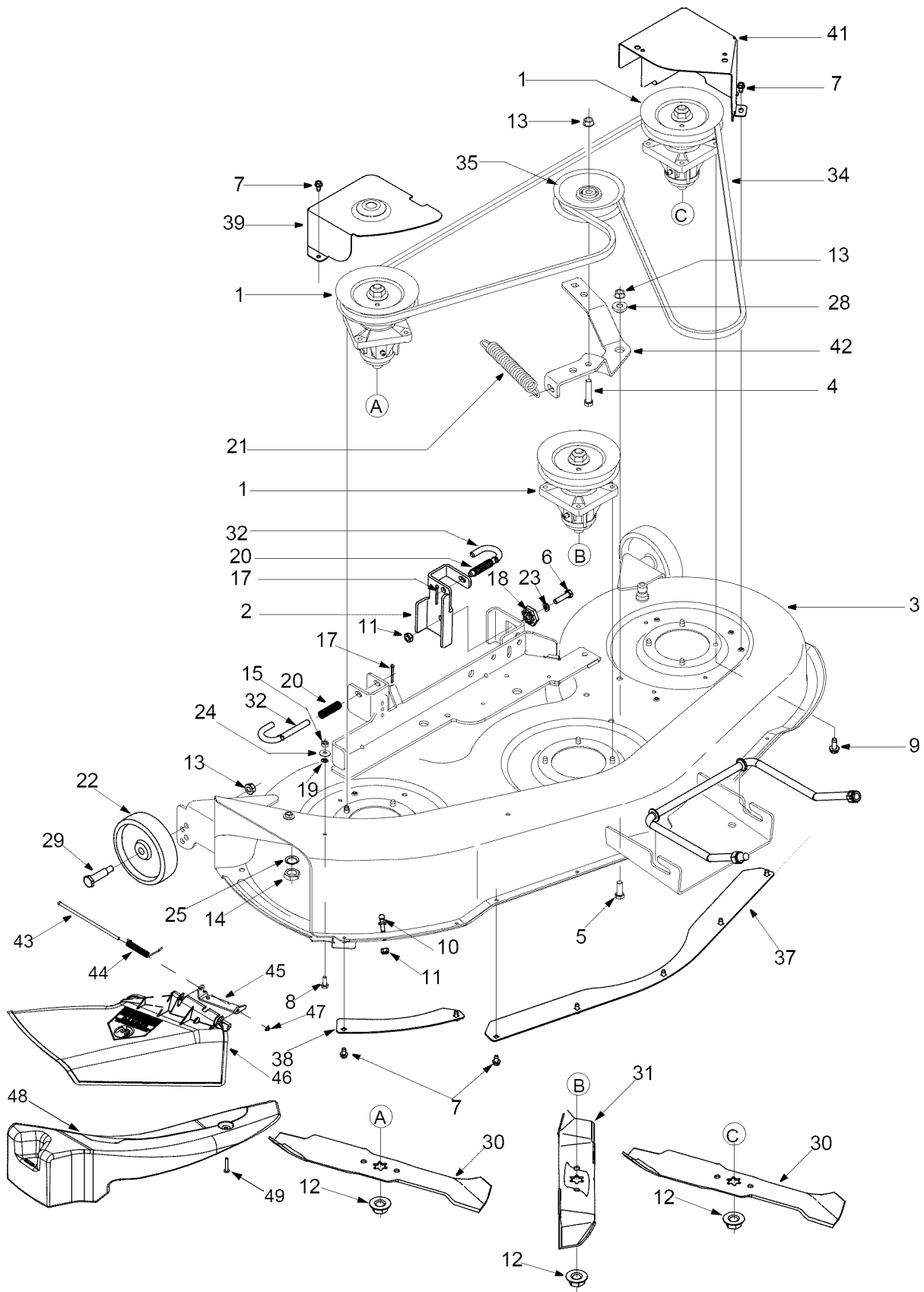

Model 604H

Ref. No.	Part No.	Description	Ref. No.	Part No.	Description
1	618-04137	Pulley-Spindle Assembly	25	736-0760	Lock Washer
2	683-0254	Deck Hanger Bracket Assembly	27	737-3007	Grease
3	683-04103	Deck Assembly	28	738-0372B	Shoulder Spacer
4	710-0347	Hex Bolt 3/8-16 x 1.75	29	738-0373	Shoulder Screw 3/8-16 x 1.5
5	710-0514	Hex Bolt 3/8-16 x 1.0	30	742-0611A	Blade 16.28 Lg.: Three-in-One
6	710-0528	Hex Bolt 5/16-18 x 1.25	31	742-0612A	Blade 14.88 Lg.: Three-in-One
7	710-0599	TT Screw 1/4-20 x 0.5	32	747-1116	Deck Release Handle
8	710-0751	Hex Bolt 1/4-20 x 0.620	34	754-04033	V Belt
9	710-1260A	LD Screw 5/16-18 x 0.75	35	756-1229	Idler Pulley
10	711-04069	Grasscatcher Pin	36	771-11725A	Danger Tag (not shown)
11	712-0324	Lock Nut 1/4-20	37	783-0141	Deck Skirt: Center
12	712-0417A	Flange Nut	38	783-0142	Deck Skirt RH
13	712-0431	Flanged Lock Nut 3/8-16	39	783-0805C	Belt Cover
14	712-0641	Hex Nut M16	40	783-1025	Chute Stop (not shown)
15	712-3006	Hex Nut	41	783-1348A	Belt Cover
16	712-3083	Hex Lock Nut 1/2-13	42	783-1421	Idler Bracket
17	714-0111	Cotter Pin	43	711-0792	Hinge Pin
18	717-04074	Gear: Deck Adjustment	44	732-0602A	Compression Spring
19	726-0233	Push Nut	45	703-1693A	Mounting Bracket
20	732-0306A	Compression Spring	46	731-1031C	Deflector: Discharge Chute
21	732-0594A	Extension Spring	47	726-0106	Speed Nut
22	734-0973	Deck Wheel	48	731-1636	Mulch Plug
23	736-0119	Lock Washer	49	710-0578	Screw 1/4-20 x 1.5
24	736-0270	Bell Washer			

MANUFACTURER'S LIMITED WARRANTY FOR:



The limited warranty set forth below is given by MTD LLC with respect to new merchandise purchased and used in the United States, its possessions and territories.

"MTD" warrants this product against defects in material and workmanship for a period of two (2) years commencing on the date of original purchase and will, at its option, repair or replace, free of charge, any part found to be defective in materials or workmanship. This limited warranty shall only apply if this product has been operated and maintained in accordance with the Operator's Manual furnished with the product, and has not been subject to misuse, abuse, commercial use, neglect, accident, improper maintenance, alteration, vandalism, theft, fire, water, or damage because of other peril or natural disaster. Damage resulting from the installation or use of any part, accessory or attachment not approved by MTD for use with the product(s) covered by this manual will void your warranty as to any resulting damage.

Normal wear parts are warranted to be free from defects in material and workmanship for a period of thirty (30) days from the date of purchase. Normal wear parts include, but are not limited to items such as: batteries, belts, blades, blade adapters, grass bags, rider deck wheels, seats, snow thrower skid shoes, shave plates, auger spiral rubber and tires.

HOW TO OBTAIN SERVICE: Warranty service is available, WITH PROOF OF PURCHASE, through your local authorized service dealer. To locate the dealer in your area, check your Yellow Pages, or contact MTD LLC at P.O. Box 361131, Cleveland, Ohio 44136-0019, or call 1-800-800-7310 or log on to our Web site at www.mtdproducts.com.

This limited warranty does not provide coverage in the following cases:

- a. The engine or component parts thereof. These items may carry a separate manufacturer's warranty. Refer to applicable manufacturer's warranty for terms and conditions.
- b. Log splitter pumps, valves, and cylinders have a separate one year warranty.
- c. Routine maintenance items such as lubricants, filters, blade sharpening, tune-ups, brake adjustments, clutch adjustments, deck adjustments, and normal deterioration of the exterior finish due to use or exposure.
- d. Service completed by someone other than an authorized service dealer.

- e. MTD does not extend any warranty for products sold or exported outside of the United States, its possessions and territories, except those sold through MTD's authorized channels of export distribution.
- f. Replacement parts that are not genuine MTD parts.
- g. Transportation charges and service calls.

No implied warranty, including any implied warranty of merchantability of fitness for a particular purpose, applies after the applicable period of express written warranty above as to the parts as identified. No other express warranty, whether written or oral, except as mentioned above, given by any person or entity, including a dealer or retailer, with respect to any product, shall bind MTD. During the period of the warranty, the exclusive remedy is repair or replacement of the product as set forth above.

The provisions as set forth in this warranty provide the sole and exclusive remedy arising from the sale. MTD shall not be liable for incidental or consequential loss or damage including, without limitation, expenses incurred for substitute or replacement lawn care services or for rental expenses to temporarily replace a warranted product.

Some states do not allow the exclusion or limitation of incidental or consequential damages, or limitations on how long an implied warranty lasts, so the above exclusions or limitations may not apply to you.

In no event shall recovery of any kind be greater than the amount of the purchase price of the product sold. **Alteration of safety features of the product shall void this warranty.** You assume the risk and liability for loss, damage, or injury to you and your property and/or to others and their property arising out of the misuse or inability to use the product.

This limited warranty shall not extend to anyone other than the original purchaser or to the person for whom it was purchased as a gift.

HOW STATE LAW RELATES TO THIS WARRANTY: This limited warranty gives you specific legal rights, and you may also have other rights which vary from state to state.

IMPORTANT: Owner must present Original Proof of Purchase to obtain warranty coverage.

MTD LLC, P.O. BOX 361131 CLEVELAND, OHIO 44136-0019; Phone: 1-800-800-7310